

Chemtech Scientific provides access to this content as a courtesy.
 We do not own the content contained in this document.
 All rights and credit go directly to its rightful owners.
www.chemtechsci.com
 Call us at: 484-424-9415



Dry Scroll Vacuum Pump

Data sheet



The new Agilent IDP-15 Dry Scroll Vacuum pump is designed for extremely quiet (<50 dBA) and low vibration operation, delivering a peak Pumping Speed of 15.4 m³/h at 60Hz; 12.8 m³/h at 50Hz.

The hermetic design with the vacuum space completely isolated from the motor and bearings provides a clean gas path through the pump, which eliminates any risk of oil or grease contamination.

Technical Specifications

Peak pumping speed:	60 Hz: 256 L/m, 15.4 m ³ /hr 50 Hz: 214 L/m, 12.8 m ³ /hr
Media:	Not suitable for use with corrosive, explosive or particulate-forming gases
Ultimate pressure:	10 x 10 ⁻³ Torr (13.3 x 10 ⁻³ mbar)
Maximum inlet pressure:	1.0 atmosphere (0 psig)
Maximum outlet pressure:	6.5 psig
Inlet connection:	NW25
Exhaust connection:	NW16
Gas ballast:	1/4" NPTF (two positions)
Water vapor handling per Pneurop 6602:	Gas Ballast Position 1: 20.7 g/hr Gas Ballast Position 2: 235 g/hr
Ambient operating temp.:	5 °C to 45 °C (41 °F to 113 °F)
Storage temperature:	-20 °C to 60 °C (-4 °F to 140 °F)
Motor rating:	0.75 HP (560 W)
Operating voltages:	1ø / 100 VAC, 50/60 Hz 1ø / 115 VAC, 60 Hz 1ø / 220-230 VAC, 50/60 Hz
Motor thermal protection:	Automatic thermal protection
Operating speed:	60 Hz: 1725 RPM, 50 Hz: 1450 RPM
Cooling system:	Air-cooled
Pump weight:	34 kg (75 lbs)
Shipping weight:	45 kg (100 lbs)
Dimensions:	364mm (14.3") h x 333mm (13.1") w x 485mm (19.1") l
Leak rate*	<1 x 10 ⁻⁶ sccs helium
Vibration level at inlet	< 9 mms ⁻¹ rms
Noise level	50 dBA ± 2dBA
Conformance standards	CE, CSA, RoHS

* (with exhaust and gas ballast sealed)

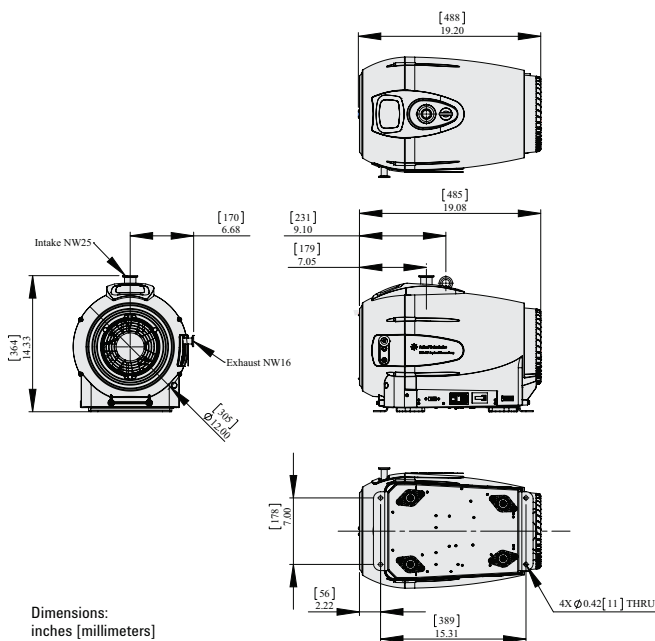

Agilent IDP-15 Dry Scroll Vacuum Pump

Data sheet

Ordering Information

Pump Part Numbers

X3815-64000	IDP15 Scroll Pump, Std
X3815-64010	IDP15 Scroll Pump, Std w/inlt vlv

Service Part Numbers

X3815-67000	IDP-15 Tip Seal Replacement Kit
-------------	---------------------------------

Spares Part Numbers

X3815-67001	Shipping Box Set, IDP-15
-------------	--------------------------

Accessories:

SCRINTRPNW25	Inlet Trap, NW25, HEPA
EXSLRSH110	Exhaust Silencer Kit, SH110

Line Cords:

656494220	Europe, 10A/220-230V, 2.5 meter
656494225	Denmark, 10A/220-230V, 2.5 meter
656494235	Switzerland, 10A/230V, 2.5 meter
656494250	UK/Ireland, 13A/230V, 2.5 meter
656494245	India, 10A/220-250V, 2.5 meter
656494230	Isreal, 10A/220-230V, 2.5 meter
656494240	Japan, 12A/100V, 2.3 meter
656458203	North America, 15A/125V, 2.0 meter
656494255	North America, 10A/230V, 2.5 meter

Pumping Speed

