

Chemtech Scientific provides access to this content as a courtesy.
We do not own the content contained in this document.
All rights and credit go directly to its rightful owners.
www.chemtechsci.com
Call us at: 484-424-9415



Vacuum Products Division

IDP-15 Dry Scroll Vacuum Pump

INSTRUCTION MANUAL

Manual No. X3815 90000
Revision B
August 2013

IDP-15 Dry Scroll Vacuum Pump



Warranty

Products manufactured by Seller are warranted against defects in materials and workmanship for twelve (12) months from date of shipment thereof to Customer, and Seller's liability under valid warranty claims is limited, at the option of Seller, to repair, to replace, or refund of an equitable portion of the purchase price of the Product. Items expendable in normal use are not covered by this warranty. All warranty replacement or repair of parts shall be limited to equipment malfunctions which, in the sole opinion of Seller, are due or traceable to defects in original materials or workmanship. All obligations of Seller under this warranty shall cease in the event of abuse, accident, alteration, misuse, or neglect of the equipment. In-warranty repaired or replaced parts are warranted only for the remaining unexpired portion of the original warranty period applicable to the repaired or replaced parts. After expiration of the applicable warranty period, Customer shall be charged at the then current prices for parts, labor, and transportation.

Reasonable care must be used to avoid hazards. Seller expressly disclaims responsibility for loss or damage caused by use of its Products other than in accordance with proper operating procedures.

Except as stated herein, Seller makes no warranty, expressed or implied (either in fact or by operation of law), statutory or otherwise; and, except as stated herein, Seller shall have no liability under any warranty, expressed or implied (either in fact or by operation of law), statutory or otherwise. Statements made by any person, including representatives of Seller, which are inconsistent or in conflict with the terms of this warranty shall not be binding upon Seller unless reduced to writing and approved by an officer of Seller.

Warranty Replacement and Adjustment

All claims under warranty must be made promptly after occurrence of circumstances giving rise thereto, and must be received within the applicable warranty period by Seller or its authorized representative. Such claims should include the Product serial number, the date of shipment, and a full description of the circumstances giving rise to the claim. Before any Products are returned for repair and/or adjustment, written authorization from Seller or its authorized representative for the return and instructions as to how and where these Products should be returned must be obtained. Any Product returned to Seller for examination shall be prepaid via the means of transportation indicated as acceptable by Seller. Seller reserves the right to reject any warranty claim not promptly reported and any warranty claim on any item that has been altered or has been returned by non-acceptable means of transportation. When any Product is returned for examination and inspection, or for any other reason, Customer shall be responsible for all damage resulting from improper packing or handling, and for loss in transit, notwithstanding any defect or non-conformity in the Product. In all cases, Seller has the sole responsibility for determining the cause and nature of failure, and Seller's determination with regard thereto shall be final.

If it is found that Seller's Product has been returned without cause and is still serviceable, Customer will be notified and the Product returned at the Customer's expense; in addition, a charge for testing and examination may be made on Products so returned.

IDP-15 Dry Scroll Vacuum Pump

This page intentionally left blank.

Contents

Instructions for Use	7
General Information	7
Storage.....	8
Maintenance	8
Technical Information	9
Unpacking and Inspection.....	13
Preparation for Installation	13
Installation.....	14
Safety	14
Setting the Mains Voltage	15
Startup.....	15
Electrical Connections.....	16
Run Currents.....	18
Start Current.....	18
Mechanical Connections	19
Operation	20
Cleaning the Pump.....	20
IDP-15 Integrated Isolation Valve	20
Troubleshooting	22
Maintenance	23
Cleaning	23
Kits and Service Options.....	23
Tip Seal Replacement.....	24

IDP-15 Dry Scroll Vacuum Pump

This page intentionally left blank.

Instructions for Use

General Information

This equipment is designed for use by professionals. The user should read this instruction manual and any other additional information supplied by Agilent before operating the equipment. Agilent will not be held responsible for any events that occur due to non-compliance with these instructions, improper use by untrained persons, non-authorized interference with the equipment, or any action contrary to that provided for by specific national standards.

The IDP-15 is a hermetic, dry scroll vacuum pump. This pump is suitable for pumping air or inert gases. The pump is not intended to pump corrosive, explosive, or particulate-forming gases.

The following paragraphs contain all the information necessary to guarantee the safety of the operator when using the equipment. Detailed information is supplied in “Technical Information” on page 10.

This manual uses the following standard safety protocol:

WARNING



The warning messages are for attracting the attention of the operator to a particular procedure or practice which, if not followed correctly, could lead to serious injury.

CAUTION



The caution messages are displayed before procedures, which if not followed, could cause damage to the equipment.

NOTE



The notes contain important information taken from the text.

IDP-15 Dry Scroll Vacuum Pump

Storage

When transporting and storing the pump, the following environmental requirements should not be exceeded:

Temperature:	-20 °C to +60 °C (-4 °F to 140 °F)
Relative humidity:	0 to 95% (non-condensing)
Atmospheric pressure:	500 to 1060 hPa

Maintenance

Personnel responsible for pump operation and maintenance must be well-trained and aware of the accident prevention rules.

WARNING



- Death may result from contact with high voltages. Always take extreme care and observe the accident prevention regulations in force.*
- When machine is powered up, be careful of moving parts and high voltages.*
- If you have to perform maintenance on the pump after a considerable time in operation, allow it to cool as the temperature of the interior metal parts can be in excess of 60 °C.*
- Always disconnect your power supply to the pump before beginning maintenance work.*

NOTE



Before returning the pump to the factory for repair, the “Health and Safety” sheet attached to this instruction manual must be completed and sent to the local sales office. A copy of the sheet must be inserted in the pump package before shipping.

If a pump is to be discarded, it must be disposed of in accordance with specific national standards.

Technical Information

Table 1 Specifications

Model	IDP-15 Dry Scroll Single Hermetic Vacuum Pump
Interface dimensions	See Figure 1 on page 12
Peak pumping speed	<input type="checkbox"/> 50 Hz: 257 L/m, 15.4 m ³ /hr <input type="checkbox"/> 60 Hz: 213 L/m, 12.8 m ³ /hr
Media	No corrosive, explosive or particulate forming gases
Ultimate pressure	10 x 10 ⁻³ Torr (13.3 x 10 ⁻³ mbar)
Maximum inlet pressure	1.0 atmosphere (0 psig)
Maximum outlet pressure	6.5 psig
Inlet connection	NW25
Exhaust connection	NW16
Gas ballast	1/4" NPTF (two positions) Water vapor handling per PNCUROP 6602: <input type="checkbox"/> Position 1: 20.7 g/hr <input type="checkbox"/> Position 2: 235 g/hr
Ambient operating temperature	5 °C to 40 °C (41 °F to 104 °F)
Storage temperature	-20 °C to 60 °C (-4 °F to 140 °F)
Motor rating	0.75 HP (560 W)
Operating voltages	<input type="checkbox"/> 1 phase/ 100 (± 10%) VAC, 50/60 Hz <input type="checkbox"/> 1 phase/ 115 (± 10%) VAC, 60 Hz <input type="checkbox"/> 1 phase/ 220-230 (± 10%) VAC, 50/60 Hz
Run current	See Table 5 on page 19
Motor thermal protection	Automatic thermal protection
Operating speed	60 Hz: 1725 RPM, 50 Hz: 1450 RPM
Cooling system	Air-cooled
Weight	Pump only: 34 kg (75 lbs) Shipping weight: 45 kg (100 lbs)
Leak rate (with exhaust and gas ballast sealed)	<1 x 10 ⁻⁶ sccs helium
Vibration level at inlet, per ISO 10816-1	9 mms ⁻¹ rms

IDP-15 Dry Scroll Vacuum Pump

Table 1 Specifications (Continued)

Noise level, per ISO 11201	50 dBA \pm 2dBA
Fuse type	Littelfuse, Series 215, 10 A, 250 V, 20 mm L x 5.2 mm D, Time Delay / Slow Blow or equivalent, vendor part number 0215010 P.
Pollution	Degree 2
Installation	Category II
Altitude	2000 m
Humidity	0- 95% (non-condensing)
Indoor use only	

IDP-15 Dry Scroll Vacuum Pump

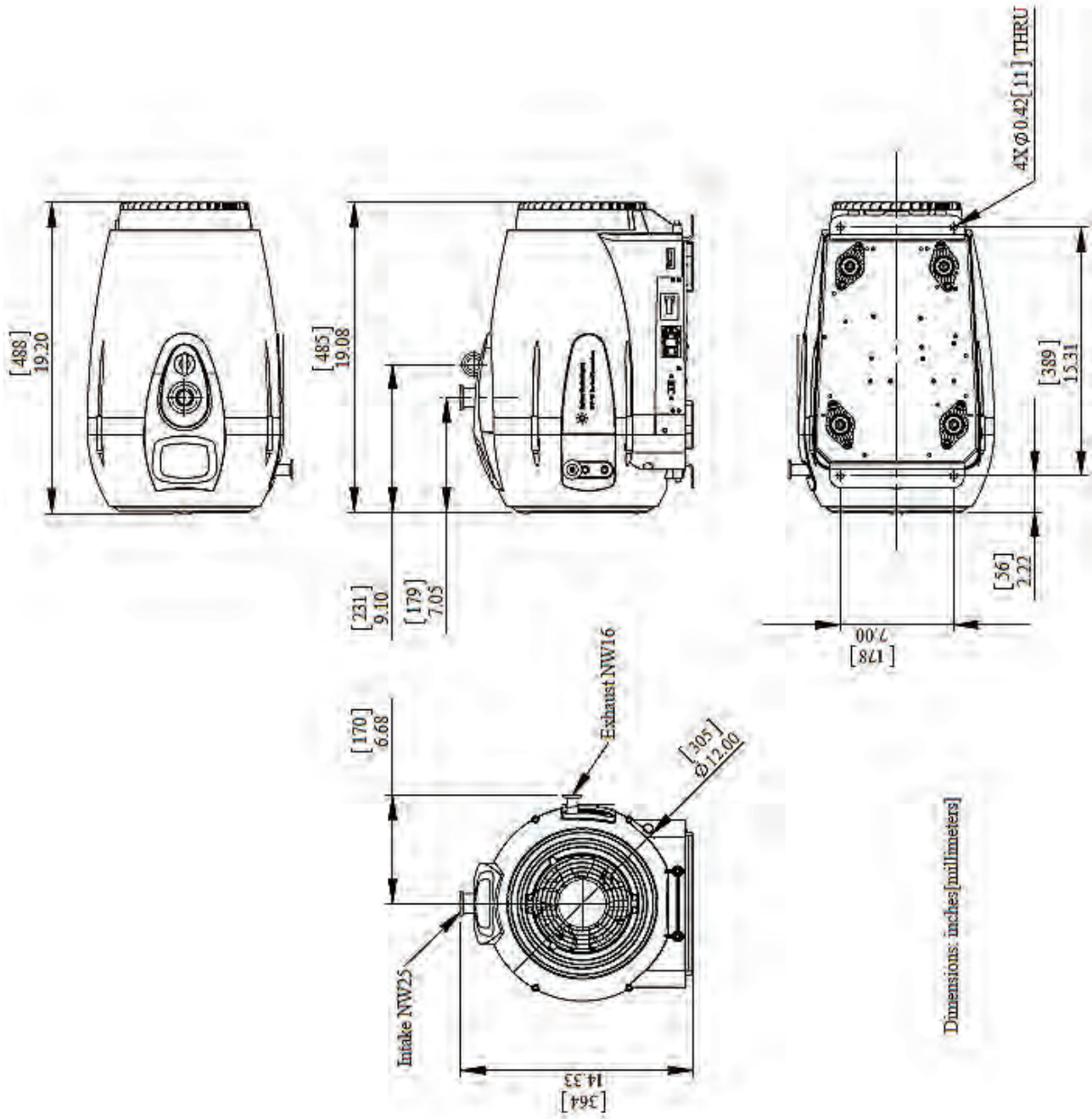
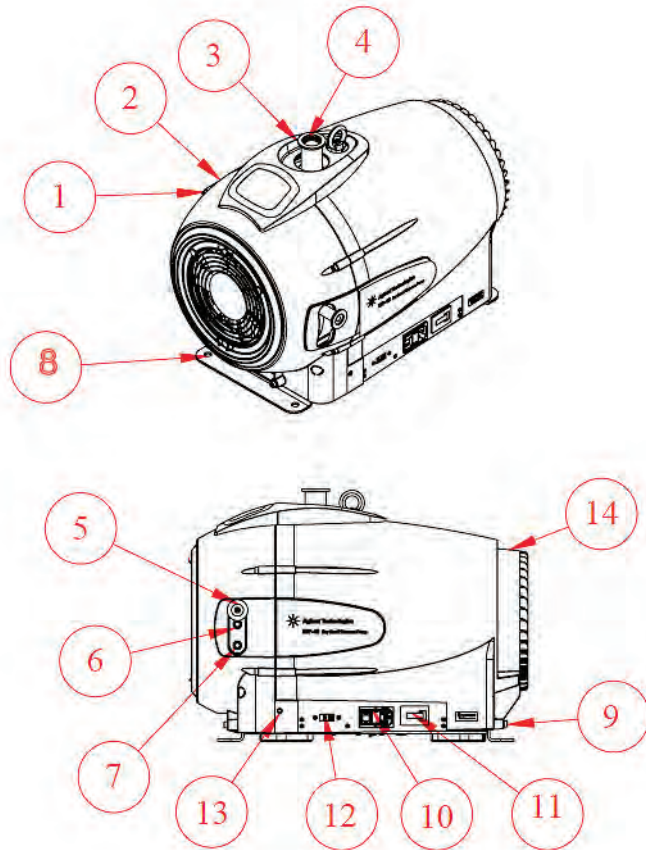

Figure 1 Interface Drawing with Dimensions

IDP-15 Dry Scroll Vacuum Pump



- ① Front Cowling Screws; M5 (6)
- ② Front Cowling
- ③ Inlet (NW25)
- ④ Inlet Screen
- ⑤ Exhaust NW16
- ⑥ Gas Ballast Port 1 (1/4" NPT filter plug, provided)
- ⑦ Gas Ballast Port 2 (1/4" NPT filter plug, provided)
- ⑧ Mounting Holes
- ⑨ Rear Cowling Screws: M5 (2)
- ⑩ On/Off Switch/Power Connection (IEC-320) and Fuse Holder
- ⑪ Hour Meter
- ⑫ Voltage Selector Switch
- ⑬ Access holes: shipping locks
- ⑭ Rear cowling

Figure 2 Outline Drawing and Principal Items

Unpacking and Inspection

Preparation for Installation

The pump is supplied in a special protective packing. If this shows signs of damage, which may have occurred during transport, contact your local sales office.

Total weight of the packing, IDP-15 pump included, is approximately 45.5 kg (100 lbs).

WARNING



When unpacking the pump, be sure not to drop it and avoid any kind of sudden impact or shock vibration to it.

NOTE



Normal exposure to the environment cannot damage the pump. Nevertheless, it is advisable to keep the pump inlet closed until the pump is installed in the system.

CAUTION



Before operating the IDP-15 disengage the shipping locks (Figure 2 on page 13).

1. Orient the shipping container with *This End Up* on top.
2. Open the box, remove the foam block and carefully lift the IDP-15 out of the box. Remove the plywood base.
3. Save the carton and all packing materials.
4. Inspect the pump for damage. If there is shipping damage, contact the freight carrier and your local Agilent sales office immediately.
5. Loosen the two front and two rear cowling screws and slide the L-brackets up. Retighten the cowling screws. The pump now rests on its rubber feet.
6. Disengage shipping locks and enable vibration isolation by inserting a 4 mm Allen wrench into each of the four shipping lock access holes (*Figure 2 on page 13*) and turning the screws clockwise until significant resistance occurs. The pump body is now floating on its isolation mounts.

CAUTION



Engage the shipping locks (Figure 2 on page 13) when shipping, moving a long distance or during long-term storage.

Installation

There are two versions of the IDP-15:

- ❑ Fixed speed: 100-115/200-230 VAC, 50/60 Hz
- ❑ Inverter drive: 100-115/200-230 VAC, 50/60 Hz, user-settable drive frequency, 40-75 Hz

During operation, the following environmental conditions must be respected:

Temperature: +5 °C to +40 °C (41 °F to 104 °F)

Relative humidity: 0 to 95% (non-condensing)

Safety

WARNING



Do not remove or modify any safety or insulating equipment from the pump. To do so may create a serious safety hazard and may void the warranty.

WARNING



The pump is designed for operation with neutral or noncorrosive gases. Do not use it with potentially explosive or inflammable substances.

WARNING



- ❑ *This pump is capable of pumping air and inert gases only. It is not designed to pump explosive, flammable, corrosive or particulate forming gases. They can cause bodily injury, explosion, or fire.*
- ❑ *Install in an area that is not exposed to rain, steam, or excessive humidity. They can cause electric shock, short circuits, and severe bodily injury.*
- ❑ *Before inspecting or servicing the pump, be sure the electrical supply is disconnected.*
- ❑ *The gas ballast must be sealed whenever pumping any gas not intended to be vented to the atmosphere*

CAUTION



- ❑ *Although the pump can pump trace particulates normally found in the atmosphere, it is not designed to process solids, chemicals, powders, solvents, condensates, or other particulates. They can damage the equipment, degrade its performance, or shorten its useful life.*
- ❑ *Do not install or use the pump in an environment exposed to atmospheric agents (rain, snow, ice), dust, aggressive gases, or in explosive environments or those with a high fire risk.*
- ❑ *If placing the IDP-15 pump inside an enclosure, provide ample room to supply ambient air to both the front and rear air intakes of the pump.*

IDP-15 Dry Scroll Vacuum Pump

CAUTION



Engage the shipping locks (Figure 2 on page 13) when shipping, moving a long distance or during long-term storage.

CAUTION



- Be certain that your electrical mains power voltage corresponds to that indicated on the fuse/voltage switch.*
- Connect the pump to the power supply using an IEC-320 style power cord of at least 10 A capacity.*

Setting the Mains Voltage

To set the mains voltage:

- Slide the voltage selector switch to 115 for 115-120 V mains, or to 230 for 200-230 V mains.

Startup

In order to reach maximum vacuum, the pump must be left running for about an hour with the inlet sealed.

There are no special instructions for starting the pump; it need only be switched on using the On/Off switch.

1. Check that the inlet screen is installed before beginning operation.

WARNING



Do not insert a finger or any foreign object in the path of the fan; serious personal injury may result or the pump may be damaged.

2. Operate the pump at an ambient temperature of 5 °C to 40 °C (41 °F to 104 °F), otherwise damage to the pump or shortened operating life may result.

CAUTION



Do not block the fan ducts. Blocking these ducts can cause pump overheating. A pump surface temperature in excess of 65 °C (150 °F) is potentially damaging. If such conditions are observed, turn the pump off and allow it to cool. Disassemble, inspect for damage, and repair, if necessary.

IDP-15 Dry Scroll Vacuum Pump

Electrical Connections

For 100/115 V service, connect the IDP-15 to a 15 A circuit. Operation in a smaller capacity circuit can cause nuisance circuit breaker trips when the motor is started, especially if mains voltage is below 100 V.

When incorporating the IDP-15 into other equipment, only use circuit breakers rated for the motor start service. Use of circuit breakers smaller than 15 A or that are not rated for motor starting can result in nuisance trips.

Power Cord

Several power cord options are available from your Agilent dealer. Descriptions of the available power cords and their ordering numbers are given in Table 3.

NOTE



For high voltage operation, the pump must be connected to the power supply using a high voltage IEC-320 type power shielded cord of at least 10 A rated capacity.

CAUTION



Be certain that your electrical mains power voltage corresponds to that indicated on the rear of the pump.

Table 3 IDP-15 Power Cord Selection

Country	Power Cord Specification	Order
Europe	10 A / 220-230 VAC, 2.5 m	656494220
Denmark	10 A / 220-230 VAC, 2.5 m	656494225
Switzerland	10 A / 230 VAC, 2.5 m	656494235
UK/Ireland	13 A / 230 VAC, 2.5 m	656494250
India	10 A / 220-250 VAC, 2.5 m	656494245
Israel	10 A / 230 VAC, 2.5 m	656494230
Japan	12 A / 100 VAC, 2.3 m	656494240
North America	15 A / 125 VAC, 2.0 m	656458203
	10 A / 230 VAC, 2.5 m	656494255

IDP-15 Dry Scroll Vacuum Pump

Grounding Instructions

This product should be grounded. In the event of an electrical short circuit, grounding reduces the risk of electric shock by providing an escape wire for the electric current. This pump must be equipped with a power cord that has a grounding wire with an appropriate grounding plug. The plug must be inserted into an outlet that is properly installed and grounded in accordance with all local codes and ordinances.

WARNING



Improper installation of the grounding plug can result in a risk of electrical shock. For United States and Canadian installations:

- When this product is configured for use on a nominal 120 V circuit, it must be used with a grounding plug that looks like the plug illustrated in Figure 4.
- If repair or replacement of the cord or plug is necessary, connect the grounding wire to the grounding terminal only.
- The grounding wire is insulated and its outer surface is green. It may or may not have yellow stripes.
- When this product is configured for use on a nominal 220 V circuit, it must be used with a factory supplied cord and plug that permits connection to the proper electric circuit. See “Electrical Connections” on page 17 for proper rating and type of cord set.

WARNING



- Check with a qualified electrician or serviceman if the grounding instructions are not completely understood, or if you are in doubt as to whether the product is properly grounded.
- Do not modify the plug provided; if it does not fit the outlet, have the proper outlet installed by a qualified electrician.
- Connect the product only to an outlet that has the same configuration as the plug. Do not use an adapter with this product.

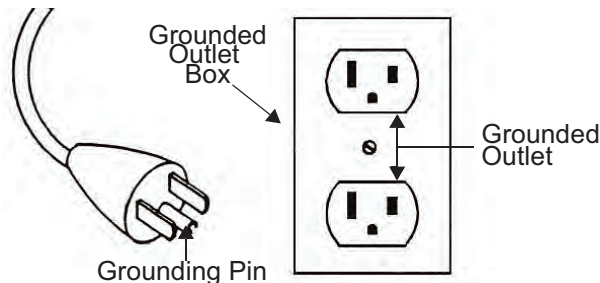

Figure 4 Grounding Plug and Outlet

WARNING



If the product must be reconnected for use on a different type of electric circuit, the connector should be replaced by qualified service personnel.

Extension Cords

Do not use extension cords.

IDP-15 Dry Scroll Vacuum Pump

Run Currents

Typical run currents listed in Table 5 are with pump blanked off.

Table 5 IDP-15 Typical Run Currents (A)

Frequency	100 V Nominal			115 V Nominal			220 V Nominal		230 V Nominal	
	90 V	100 V	110 V	103.5 V	115 V	127 V	198 V	220 V	230 V	253 V
60 Hz	4.23	4.06	4.02	4.03	4.06	4.74	2.87	2.77	2.64	2.51
50 Hz	4.20	4.50	6.13	N/A	N/A	N/A	1.93	2.42	2.81	4.02

Start Current

Table 6 lists the typical IDP-15 maximum starting current and duration.

Table 6 Typical IDP-15 Maximum Starting Current and Duration

Mains Voltage	50 Hz		60 Hz	
	Current (A)	Time (ms)	Current (A)	Time (ms)
100 V	22.6	< 1 sec.	23.5	< 1 sec.
115 V	N/A	N/A	21.2	< 1 sec.
220 V	11.9	< 1 sec.	14.2	< 1 sec.
230 V	11.7	< 1 sec.	13.9	< 1 sec.

IDP-15 Dry Scroll Vacuum Pump

Mechanical Connections

Pump Inlet

Use NW25, or larger, clean vacuum hardware with as short a length as practical between the pump and vacuum chamber.

Insert a bellows between the pump and vacuum chamber to provide both vibration isolation and strain relief.

Pump Exhaust

An NW16 exhaust fitting is located on the side of the pump. To avoid overheating the pump, do not restrict the exhaust flow with long lengths of small diameter tubing. Use as short as practical lengths of 16 mm ID, or larger, diameter hardware.

Gas Ballast

When pumping gas loads containing water vapor or condensable gases, use the gas ballast. To activate gas ballast, remove the solid 1/4 NPT plug from either port 1 or port 2, and install the sintered filter plug provided with the pump (see Figure 2 on page 13).

CAUTION

If hazardous materials are pumped, do not use gas ballast.



Gas ballast port 1 is used for moderate water vapor loads (up to 20.7 g/hr), such as intermittently pumping out a volume exposed to normal ambient humidity. Gas ballast port 2 is used for high water vapor loads (up to 235 g/hr), such as repetitively pumping out a volume exposed to excessive ambient humidity, or process gas loads with a high water vapor content.

For applications where ingress of air is undesirable, dry nitrogen at a flow rate of approximately 5 l/min can be provided to the gas ballast inlet by making a 1/4 NPT connection to the port.

CAUTION

Pumping high water vapor loads can cause a temporary increase in ultimate pressure, due to adsorption and absorption of water vapor by the internal surfaces of the pump. Pumping water vapor loads in excess of the water vapor handling capability of the gas ballast can cause reduced time between tip seal replacements.



Operation

Cleaning the Pump

Unlike conventional oil-sealed pumps, Agilent dry scroll pumps do not contain fluid for the cleansing of accumulated dust and debris. Run the pump periodically with the inlet open to atmosphere for a minute or two to flush it out. Until experience is gained on your specific process, flush the pump regularly and adjust this schedule according to your specific conditions.

IDP-15 Integrated Isolation Valve

The IDP-15 scroll pump offers an optional, factory-installed Integrated Isolation Valve built into pump module. This option is installed into the body of the pump and does not affect the external size of the pump or the height of the inlet flange.

All IDP-15 scroll pumps are supplied with an exhaust valve to prevent rapid leak-up to atmospheric pressure. However, any vacuum pump generates a small increase in inlet line pressure when turned off. This can cause a small amount of pump debris to be carried back into the vacuum line or chamber when pump power is interrupted. For applications where the process is sensitive to contamination from pump debris, install a fast acting, automatic, normally closed valve at the pump inlet to prevent pump debris from migrating backwards through the pump inlet.

The Integrated Isolation Valve is a safety valve that protects the vacuum system in the event of power failure by isolating the vacuum system from the vacuum pump and venting the pump to atmospheric pressure. The Integrated Isolation Valve is designed to prevent any tip seal debris back streaming into the vacuum system. The valve operates with atmospheric pressure and activates upon loss of electrical power. The lifetime is in excess of 200,000 cycles, which translates into years of trouble free use in suitable environments. The opening burst pressure, approximately 5×10^{-2} Torr, is typically less than the critical backing pressure for turbo molecular and diffusion pumps.

The Integrated Isolation Valve's solenoid valve is connected in parallel with the IDP-15 electrical supply. When the electrical power is on, the solenoid valve is closed, which allows the pump to keep the Integrated Isolation Valve's body and the vacuum system evacuated. Interruption of electrical power to the pump causes the solenoid valve to open. Air is admitted into the Integrated Isolation Valve causing it to close very quickly. This isolates the vacuum system from the pump, while the pressure differential between the outside atmosphere (inside the pump) and the vacuum system provides the force necessary to maintain the valve in its closed position without electric or pneumatic power.

IDP-15 Dry Scroll Vacuum Pump

With the vacuum system isolated, a very small orifice admits air from the inside the pump to the lower chamber of the Integrated Isolation Valve until its pressure has risen to atmospheric pressure. When the pump is restarted, it starts to evacuate the valve's lower chamber volume first until the pressure is lowered to approximately that of the vacuum system. At that moment the spring activated diaphragm automatically opens again (with a 10 sec delay to avoid back burst in the vacuum system) allowing the vacuum system to be pumped at the full speed of the pump.

IDP-15 Dry Scroll Vacuum Pump

Troubleshooting

Use the Troubleshooting chart in Table 7 to assist in defining a problem, determining a possible cause, and defining action steps to remedy the situation.

Table 7 Troubleshooting Chart

Problem	Possible Causes	Corrective Actions
Will not start	Motor thermal protector open	Allow motor to cool. Identify cause of overload.
	Blown fuse	Replace fuse.
	Excessive voltage drop	Check size and length of cable.
	Defective motor	Inspect. Contact Agilent.
Poor ultimate pressure	System leak	Locate and repair leak.
	Water in pump	Flush pump with air or dry nitrogen.
	Solvent in pump	Flush pump with air or dry nitrogen. Install trap or filter.
	Seals worn out	Replace tip seals.
	Poor conductance to pump	Replumb with shorter and/or larger diameter tubing.
	Integrated Isolation Valve (option) solenoid failure	Contact Agilent.
Hammering noise	Pump overheated	Check ventilation to pump. Check ambient temperature.
	Debris in pump	Check intake screen. Flush pump. Disassemble pump and inspect.
Pump runs intermittently	Motor thermal protector is cycling open and closed.*	Allow the motor to cool. Identify the cause of the overload.

* *The IDP-15 is equipped with an auto-reset thermal motor protector. This protector automatically shuts down the pump when it detects an overload condition, and automatically restarts the pump when the motor has cooled to within an acceptable temperature range.*

Maintenance

Cleaning

Exterior

The exterior surfaces of the IDP-15 may be cleaned with alcohol or mild detergents only.

Interior

Run the pump periodically with the inlet open at atmosphere for a minute or two to flush it out. For more information, see “Cleaning the Pump” on page 21.

Kits and Service Options

Agilent pumps will provide many years of trouble-free service if the maintenance procedures and intervals are observed. Cleaning and tip seal replacement are recommended when pump base pressure has risen to an unacceptably high level for your application. If your pump exhibits humming or grinding noises from the bearings, a major overhaul should be done by Agilent personnel or an authorized rebuild center. Advance exchange pumps are available to minimize downtime.

The parts needed for tip seal replacement on the IDP-15 are available in the kit described in Table 8. This kit contains seals and O-rings, and can be obtained from your Agilent dealer.

Table 8 Tip Seal Replacement Kit

Part Number	Description	Contents
X3815-67000	Replacement Tip Seal Set	Replacement Tip Seal and O-ring and grease for IDP-15 pumps

IDP-15 Dry Scroll Vacuum Pump

Tip Seal Replacement

Required Equipment

- ❑ *Tip Seal Replacement Kit: P/N X3815-67000*
- ❑ Pry tool (screwdriver or something with a flat edge the size of the tip seal)
- ❑ Lint-free wipes
- ❑ 4 mm and 5 mm Allen wrenches
- ❑ Isopropyl alcohol

WARNING



If dangerous gases were being pumped, ensure the pump is clear of all dangerous materials prior to disassembly.

IDP-15 Disassembly



Remove the Front Fan Cowling

1. Disconnect the power cord.



2. Remove the two screws holding the bottom bracket using a 4 mm Allen key.
3. Support the cowling from the bottom with one hand.
4. Loosen the four captive screws (two on left side not shown) holding the cowling.

IDP-15 Dry Scroll Vacuum Pump

IDP-15 Disassembly (Continued)



5. Rotate the cowl so that it clears the exhaust port (red arrow).

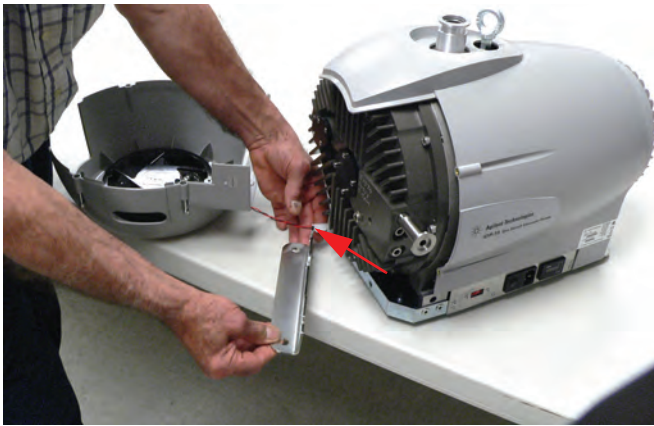

6. Remove the cowl and lay it on its back.
7. Disconnect the white plug (red arrow). This is an integral lock connector and is keyed to plug together only one way.
8. Remove the cowl to the side.
9. Remove the L-bracket and place to the side.



10. Lift the top console (red arrow) from the front and rotate to one side.

IDP-15 Dry Scroll Vacuum Pump

IDP-15 Disassembly (Continued)

Remove the Outboard Housing and Remove Tip Seals

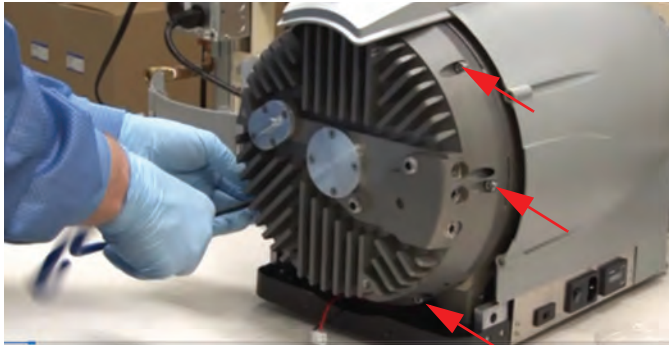

1. Use an 5 mm Allen key to remove the six screws on the outboard housing (the three screws on left not shown).

Remove the lower screws first to support the housing.

2. Remove the housing and place to the side.



3. Remove the O-ring and discard.

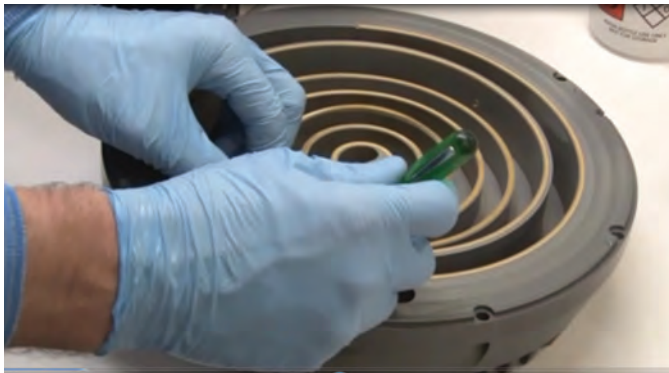

4. Using a pry tool, remove the old tip seals. There are a long and short tip seal on both the orbiting plate and the outboard housing.

5. Clean all debris from the orbiting plate, outboard housing and O-ring groove. Use alcohol along with cotton swabs and wipes.

IDP-15 Dry Scroll Vacuum Pump

IDP-15 Disassembly (Continued)



Tip Seal Replacement

1. Remove the new tip seal from the kit. The tip seal is supplied in one length, sufficient to create a short and a long segment for the orbiting plate and the outboard housing (four segments total). The tip seal cross section is rectangular. The width is less than the height.

2. Install each tip seal segment, starting at the inside so the 1/8" gap occurs at the end. Use a flat wooden or plastic tool to press each segment into its lock (red arrow). Each segment has a lock (four total). Clean away any tip seal debris generated when pressed into each lock.

3. Cut each tip seal segment to a length that leaves an 1/8" gap at the end.

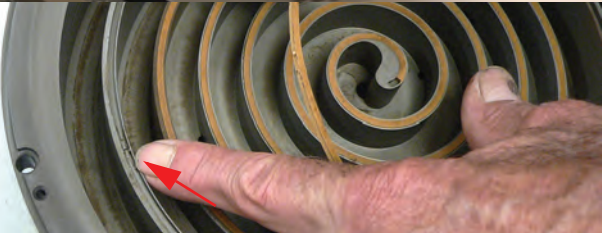

4. Lightly lubricate the O-ring with a trace of vacuum grease. Use the Krytox 224 grease supplied with the kit. Krytox LVP or Apezion L can be substituted. Do not use vacuum grease containing silicone.



IDP-15 Dry Scroll Vacuum Pump

IDP-15 Reassembly

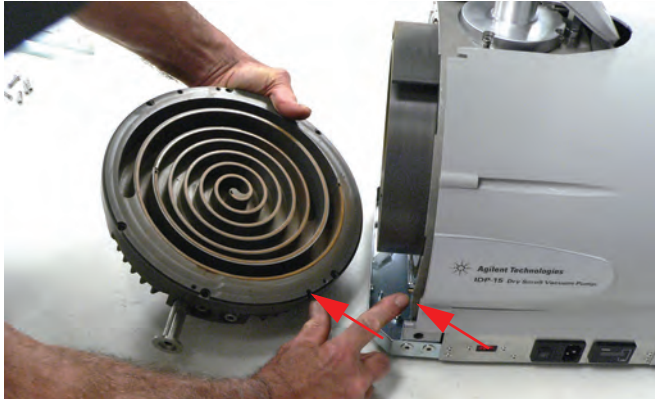

1. Align the outboard housing with the orbiting plate using the pin and pin alignment hole shown by the red arrows. Ensure that the tip seals and O-ring do not get pinched or misaligned.
2. Reinstall the six screws and tighten.

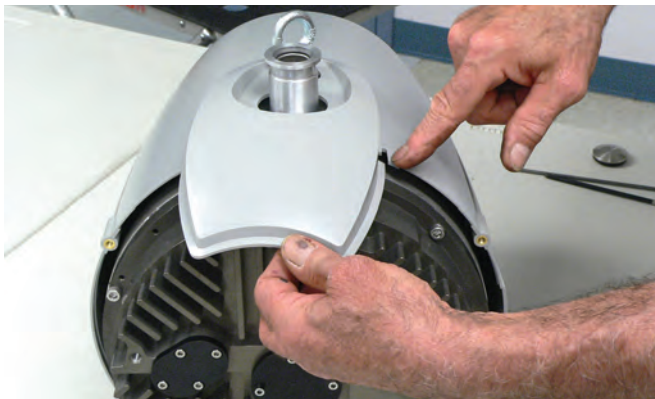

3. Reinstall the console by swinging it back and aligning it with the body slots as shown.



4. Place the bracket against the electrical tray and align the bracket slots with the tapped holes in the tray.
5. Plug the red/black fan connector together.
6. Align fan cowling by wiggling it over the exhaust port. Replace and tighten the four fan cowling screws.
7. Replace the two screws at the bottom of the fan cowling. Lift and hold the bracket while tightening these screws.
8. Reinstall the power cord.

To test the pump:

1. Run the pump for about 5 seconds. Verify that the front fan is running.

If you hear loud noises or observe labored operation, this indicates that the tip seal or main O-ring are possibly out of place.

2. Disassemble and repair as necessary.

IDP-15 Dry Scroll Vacuum Pump

The pump is now ready to return to service.

NOTE



Newly installed tip seals may require several hours of run time to seat properly and enable the pump to meet speed and base pressure specifications.

Chemtech Scientific provides access to this content as a courtesy.
We do not own the content contained in this document.
All rights and credit go directly to its rightful owners.
www.chemtechsci.com
Call us at: 484-424-9415



Vacuum Products Division Instructions for returning products

Dear Customer:

Please follow these instructions whenever one of our products needs to be returned.

- 1) Complete the attached Request for Return form and send it to Agilent Technologies (see below), taking particular care to identify all products that have pumped or been exposed to any toxic or hazardous materials.
- 2) After evaluating the information, Agilent Technologies will provide you with a Return Authorization (RA) number via email or fax, as requested.
Note: Depending on the type of return, a Purchase Order may be required at the time the Request for Return is submitted. We will quote any necessary services (evaluation, repair, special cleaning, eg).
- 3) **Important steps for the shipment of returning product:**
 - Remove all accessories from the core product (e.g. inlet screens, vent valves).
 - Prior to shipment, drain any oils or other liquids, purge or flush all gasses, and wipe off any excess residue.
 - If ordering an Advance Exchange product, **please use the packaging from the Advance Exchange to return the defective product.**
 - Seal the product in a plastic bag, and package product carefully to avoid damage in transit. You are responsible for loss or damage in transit.
 - Agilent Technologies is not responsible for returning customer provided packaging or containers.
 - **Clearly label package with RA number.** Using the shipping label provided will ensure the proper address and RA number are on the package. Packages shipped to Agilent without a RA clearly written on the outside cannot be accepted and will be returned.
- 4) Return only products for which the RA was issued.
- 5) **Product being returned under a RA must be received within 15 business days.**
- 6) **Ship to the location specified on the printable label, which will be sent, along with the RA number, as soon as we have received all of the required information.** Customer is responsible for freight charges on returning product.
- 7) Return shipments must comply with all applicable **Shipping Regulations** (IATA, DOT, etc.) and carrier requirements.

RETURN THE COMPLETED **REQUEST FOR RETURN** FORM TO YOUR NEAREST LOCATION:



Vacuum Products Division

Please read important policy information on Page 3 that applies to all returns.

1) CUSTOMER INFORMATION

Company Name:		Contact Name:	
Tel:	Email:	Fax:	
Customer Ship To:		Customer Bill To:	
Europe only: VAT reg. Number:		USA/Canada only: <input type="checkbox"/> Taxable <input type="checkbox"/> Non-taxable	

2) PRODUCT IDENTIFICATION

Product Description	Agilent P/N	Agilent S/N	Original Purchasing Reference

3) TYPE OF RETURN (Choose one from each row and supply Purchase Order if requesting a billable service)

- 3A. Non-Billable Billable **➔** New PO # (hard copy must be submitted with this form):
- 3B. Exchange Repair Upgrade Consignment/Demo Calibration Evaluation Return for Credit

4) HEALTH and SAFETY CERTIFICATION

AGILENT TECHNOLOGIES CANNOT ACCEPT ANY PRODUCTS CONTAMINATED WITH BIOLOGICAL OR EXPLOSIVE HAZARDS, RADIOACTIVE MATERIAL, OR MERCURY AT ITS FACILITY.

Call Agilent Technologies to discuss alternatives if this requirement presents a problem.

The equipment listed above (check one):

- HAS NOT** pumped or been exposed to any toxic or hazardous materials. OR
- HAS** pumped or been exposed to the following toxic or hazardous materials. If this box is checked, the following information must also be filled out. Check boxes for all materials to which product(s) pumped or was exposed:

Toxic Corrosive Reactive Flammable Explosive Biological Radioactive

List all toxic/hazardous materials. Include product name, chemical name, and chemical symbol or formula:

NOTE: If a product is received at Agilent which is contaminated with a toxic or hazardous material that was not disclosed, **the customer will be held responsible** for all costs incurred to ensure the safe handling of the product, and **is liable** for any harm or injury to Agilent employees as well as to any third party occurring as a result of exposure to toxic or hazardous materials present in the product.

Print Name: _____ **Authorized Signature:** **Date:** _____

5) FAILURE INFORMATION:

Failure Mode (REQUIRED FIELD. See next page for suggestions of failure terms):

Detailed Description of Malfunction: (Please provide the error message)

Application (system and model):

I understand and agree to the terms of Section 6, Page 3/3.

Print Name: _____ **Authorized Signature:** **Date:** _____



**Vacuum Products Division
Request for Return Form
(Health and Safety Certification)**

Please use these Failure Mode to describe the concern about the product on Page 2.

TURBO PUMPS and TURBO CONTROLLERS

APPARENT DEFECT/MALFUNCTION	POSITION	PARAMETERS
- Does not start - Does not spin freely - Does not reach full speed - Mechanical Contact - Cooling defective - Noise - Vibrations -Leak -Overtemperature -Clogging	- Vertical -Horizontal -Upside-down -Other:	Power: Rotational Speed: Current: Inlet Pressure: Temp 1: Foreline Pressure: Temp 2: Purge flow: OPERATING TIME:

ION PUMPS/CONTROLLERS

- Bad feedthrough - Vacuum leak - Error code on display - Poor vacuum - High voltage problem - Other

VALVES/COMPONENTS

- Main seal leak - Solenoid failure - Damaged sealing area - Bellows leak - Damaged flange -Other
--

LEAK DETECTORS

- Cannot calibrate - Vacuum system unstable - Failed to start -No zero/high background - Cannot reach test mode - Other
--

INSTRUMENTS

- Gauge tube not working - Communication failure - Error code on display - Display problem - Degas not working - Other

SCROLL AND ROTARY VANE PUMPS

- Pump doesn't start - Doesn't reach vacuum - Pump seized - Noisy pump (describe) - Over temperature - Other

DIFFUSION PUMPS

- Heater failure - Doesn't reach vacuum - Vacuum leak - Electrical problem - Cooling coil damage - Other

Section 6) **ADDITIONAL TERMS**

Please read the terms and conditions below as they apply to all returns and are in addition to the Agilent Technologies Vacuum Product Division – Products and Services Terms of Sale.

- Customer is responsible for the freight charges for the returning product. Return shipments must comply with all applicable **Shipping Regulations** (IATA, DOT, etc.) and carrier requirements.
- Customers receiving an Advance Exchange product agree to return the defective, rebuildable part to Agilent Technologies **within 15 business days**. Failure to do so, or returning a non-rebuildable part (crashed), will result in an invoice for the non-returned/non-rebuildable part.
- Returns for credit toward the purchase of new or refurbished Products are subject to prior Agilent approval and may incur a restocking fee. Please reference the original purchase order number.
- Units returned for evaluation will be evaluated, and a quote for repair will be issued. If you choose to have the unit repaired, the cost of the evaluation will be deducted from the final repair pricing. A Purchase Order for the final repair price should be issued within 3 weeks of quotation date. Units without a Purchase Order for repair will be returned to the customer, and the evaluation fee will be invoiced.
- A Special Cleaning fee will apply to all exposed products per Section 4 of this document.
- If requesting a calibration service, units must be functionally capable of being calibrated.