

# **TriScroll™ 800 Inverter Dry Scroll Vacuum Pump**

## *Installation and Operation Manual*

Chemtech Scientific provides access to this content as a courtesy.  
We do not own the content contained in this document.  
All rights and credit go directly to its rightful owners.  
[www.chemtechsci.com](http://www.chemtechsci.com)  
Call us at: 484-424-9415



Manual No. 699904435

Revision C.00

February 2021

# Table of Contents

<b>Warranty</b> .....	<b>v</b>
<b>Instructions for Use</b> .....	<b>1</b>
General Information .....	1
Installation .....	3
Use .....	3
Maintenance .....	3
Environmental Conditions, Compliance and Utility Requirements .....	4
<b>Instructions d'utilisation</b> .....	<b>5</b>
Avertissements CEM .....	6
Installation .....	7
Utilisation .....	7
Entretien .....	8
<b>Instrucciones de Uso</b> .....	<b>9</b>
Información general .....	9
Instalación .....	11
Uso .....	11
Mantenimiento .....	11
<b>Istruzioni per l'uso</b> .....	<b>12</b>
Avvertenze CEM .....	13
Installazione .....	14
Utilizzo .....	14
Manutenzione .....	15
<b>Anwendungshinweise</b> .....	<b>16</b>
Hinweise zur elektromagnetischen Verträglichkeit .....	17
Installation .....	18
Betrieb .....	18
Wartung .....	19
<b>使用上の注意</b> .....	<b>20</b>
一般情報 .....	20
設置 .....	22
使用 .....	22
メンテナンス .....	22
使用说明 .....	23
<b>包装</b> .....	<b>23</b>
CEM 警告 .....	24
<b>安装</b> .....	<b>25</b>
用途 .....	25
维护 .....	26
Mechanical Connections .....	28
Operation .....	29
TriScroll 800 Inverter Pump Components View .....	30
<b>Technical Information</b> .....	<b>31</b>
Pump Electrical Controller .....	33
Purge Kit .....	36

Exhaust Silencer Kit .....	36
Vibration Isolation Kit .....	36
HEPA Inlet filter .....	36
Troubleshooting .....	37
Maintenance .....	38

## Request for Return Health and Safety Certification

# Warranty

Products manufactured by Seller are warranted against defects in materials and workmanship for twelve (12) months from date of shipment thereof to Customer, and Seller's liability under valid warranty claims is limited, at the option of Seller, to repair, to replace, or refund of an equitable portion of the purchase price of the Product. Items expendable in normal use are not covered by this warranty. All warranty replacement or repair of parts shall be limited to equipment malfunctions which, in the sole opinion of Seller, are due or traceable to defects in original materials or workmanship. All obligations of Seller under this warranty shall cease in the event of abuse, accident, alteration, misuse, or neglect of the equipment. In-warranty repaired or replaced parts are warranted only for the remaining unexpired portion of the original warranty period applicable to the repaired or replaced parts. After expiration of the applicable warranty period, Customer shall be charged at the then current prices for parts, labor, and transportation.

Reasonable care must be used to avoid hazards. Seller expressly disclaims responsibility for loss or damage caused by use of its Products other than in accordance with proper operating procedures.

Except as stated herein, Seller makes no warranty, express or implied (either in fact or by operation of law), statutory or otherwise; and, except as stated herein, Seller shall have no liability under any warranty, express or implied (either in fact or by operation of law), statutory or otherwise. Statements made by any person, including representatives of Seller, which are inconsistent or in conflict with the terms of this warranty shall not be binding upon Seller unless reduced to writing and approved by an officer of Seller.

## Warranty Replacement and Adjustment

All claims under warranty must be made promptly after occurrence of circumstances giving rise thereto, and must be received within the applicable warranty period by Seller or its authorized representative. Such claims should include the Product serial number, the date of shipment, and a full description of the circumstances giving rise to the claim. Before any Products are returned for repair and/or adjustment, written authorization from Seller or its authorized representative for the return and instructions as to how and where these Products should be returned must be obtained. Any Product returned to Seller for examination shall be prepaid via the means of transportation indicated as acceptable by Seller. Seller reserves the right to reject any warranty claim not promptly reported and any warranty claim on any item that has been altered or has been returned by non-acceptable means of transportation. When any Product is returned for examination and inspection, or for any other reason, Customer shall be responsible for all damage resulting from improper packing or handling, and for loss in transit, notwithstanding any defect or non-conformity in the Product. In all cases, Seller has the sole responsibility for determining the cause and nature of failure, and Seller's determination with regard thereto shall be final.

If it is found that Seller's Product has been returned without cause and is still serviceable, Customer will be notified and the Product returned at its expense; in addition, a charge for testing and examination may be made on Products so returned.

# Instructions for Use

## General Information

This equipment is designed for use by trained personnel. The user should read this instruction manual and any other additional information supplied by Agilent before operating the equipment. Agilent will not be held responsible for any events that occur due to non-compliance with these instructions, improper use by untrained persons, non-authorized interference with the equipment, or any action contrary to that provided for by specific national standards.

The TS800 is a dry scroll vacuum pump. This pump is suitable for pumping air or inert gases. The pump is not intended to pump corrosive, explosive, or particulate-forming gases.

The following paragraphs contain all the information necessary to guarantee the safety of the operator when using the equipment. Detailed information is supplied in “Technical Specifications” on page 33.

This manual uses the following standard safety protocol:

**ADVERTENCIA** *The warning messages are for attracting the attention of the operator to a particular procedure or practice which, if not followed correctly, could lead to serious injury.*



**PRECAUCIÓN** *The caution messages are displayed before procedures, which if not followed, could cause damage to the equipment.*



**NOTA** *The notes contain important information taken from the text.*



## Storage

When transporting and storing the pump, the following environmental requirements should not be exceeded:

Temperature:  $-20^{\circ}\text{C}$  to  $+60^{\circ}\text{C}$  ( $-4^{\circ}\text{F}$  to  $140^{\circ}\text{F}$ )  
Relative humidity: 0 to 95% (non-condensing)

## Preparation for Installation

The pump is supplied in a special protective packing. If this shows signs of damage, which may have occurred during transport, contact your local sales office.

Total weight of the packing, TS800 pump included, is approximately 42 kg (93 lbs).

**ADVERTENCIA** *The TS800 pump itself weighs 32 kg (71 lbs). To avoid injury, use lifting aids and proper lifting techniques when moving the pump.*



**ADVERTENCIA** *When unpacking the pump, be sure not to drop it and avoid any kind of sudden impact or shock vibration to it.*



**NOTA** *Normal exposure to the environment cannot damage the pump. Nevertheless, it is advisable to keep the pump inlet closed until the pump is installed in the system.*



## EMC Warnings

### EN 55011 Class A Warning

This is a Class A product. In a domestic environment this product may cause radio interference in which case the user may be required to take adequate measures.

## FCC

This device complies with Part 15 of the FCC rules. Operation is subject to the following two conditions: (1) This device may not cause harmful interference, and (2) this device must accept any interference received, including interference that may cause undesirable operation.

### NOTE



*The equipment has been tested and found to comply with the limits for a Class A digital device, pursuant to Part 15 of the FCC rules. These limits are designed to provide reasonable protection against harmful interference when the equipment is operated in a commercial environment. This equipment generated, uses, and can radiate radio frequency energy and, if not installed and used in accordance with the instruction manual, may cause harmful interference to radio communications. Operation of this equipment in a residential area is also likely to cause harmful radio communications interference in which case the user will be required to correct the interference at his own expense.*

## Installation

The TS800 is *NOT* intrinsically safe. Do not install or use the pump in an environment exposed to atmospheric agents (rain, snow, ice), dust, aggressive gases, or in explosive environments or those with a high fire risk.

During operation, the following environmental conditions must be respected:

Temperature: +5 °C to +40 °C (41 °F to 104 °F)  
Relative humidity: 0 to 95% (non-condensing)

Connect the pump to the power supply using an IEC-320 style power cord of at least 10 A capacity (see Table 1 on page 27).

### CAUTION



*When installing the vacuum pump it is recommended that the pump be positioned in a way that the power switch and power cord connection remain easily accessible to the user in order to be available as an option to disconnect power to the pump quickly if needed.*

## Use

In order to reach maximum vacuum, the pump must be left running for at least an hour with the inlet sealed.

There are no special instructions for starting the pump; it need only be switched on using the On/Off switch.

The optional inlet valve will open 30 seconds after the pump is started.

### WARNING



*The pump is designed for operation with neutral or noncorrosive fluids. It is absolutely forbidden to use it with potentially explosive or inflammable substances.*

There are no special instructions for stopping the pump; it need only be disconnected from the electric power source by the On/Off switch.

The optional inlet valve will close immediately after the pump is stopped.

## Maintenance

Personnel responsible for pump operation and maintenance must be well-trained and aware of the accident prevention rules.

### WARNING



- *Death may result from contact with high voltages. Always take extreme care and observe the accident prevention regulations in force.*
- *When machine is powered up, be careful of moving parts and high voltages.*
- *If you have to perform maintenance on the pump after a considerable time in operation, allow it to cool as the temperature of the outer surface may be in excess of 60 °C.*
- *Always disconnect your power supply to the pump before beginning maintenance work.*

### NOTE



*Before returning the pump to the factory for repair, the "Request for Return" sheet attached to this instruction manual must be completed and sent to the local sales office. A copy of the sheet must be inserted in the pump package before shipping.*

If a pump is to be discarded, it must be disposed of in accordance with specific national standards.

### Disposal

Meaning of the WEEE logo found in labels.

The following symbol is applied in accordance with the EC WEEE (Waste Electrical and Electronic Equipment) Directive. This symbol (valid only in countries of the European Community) indicates that the product it applies to must NOT be disposed of together with ordinary domestic or industrial waste but must be sent to a differentiated waste collection system.

The end user is therefore invited to contact the supplier of the device, whether the Parent Company or a retailer, to initiate the collection and disposal process after checking the contractual terms and conditions of sale.



# Environmental Conditions, Compliance and Utility Requirements

## Environmental Conditions

This equipment meets the following IEC classifications:

- Pollution Degree 2 (See Note.)
- Installation Category II (See Note.)
- Equipment Class 1

### NOTE



*Pollution level describes the degree to which a solid, liquid, or gas which deteriorates dielectric strength is adhering. 2 applies to a normal indoor atmosphere.*

*Installation category implies the regulation for impulse withstand voltage. It is also called the Over voltage category. II applies to electrical equipment.*

*This equipment requires the following space for ventilation, maintenances access, and easy access to the Main Power Breaker Switch. There must be a clear space of at least 60 cm (24") on all sides of the equipment. The bench in your laboratory must be able to support the entire system and other laboratory equipment.*

## Electromagnetic Compatibility

### EN55011/CISPR11

**Group 1 ISM equipment:** Group 1 contains all ISM equipment in which there is intentionally generated and/or used conductively coupled radio-frequency energy which is necessary for the internal functioning of the equipment itself.

**Class A equipment** is equipment suitable for use in all establishments other than domestic and those directly connected to a low voltage power supply network which supplies buildings used for domestic purposes.

This device complies with the requirements of CISPR11, Group 1, Class A as radiation professional equipment. Therefore, there may be potential difficulties in ensuring electromagnetic compatibility in other environments, due to conducted as well as radiated disturbances.

Operation is subject to the following two conditions:

- This device may not cause harmful interference.
- This device must accept any interference received, including interference that may cause undesired operation.

If this equipment does cause harmful interference to radio or television reception, which can be determined by turning the equipment off and on, the user is encouraged to try one or more of the following measures:

- Make sure that appropriate cables are used to connect the device to peripheral equipment.
- Changes or modifications not expressly approved by Agilent Technologies could void the user's authority to operate the equipment.

## South Korean Class A EMC declaration

This equipment is Class A suitable for professional use and is for use in electromagnetic environments outside of the home.

A 급 기기  
(업무용 방송통신기자재)

이 기기는 업무용 (A 급) 전자파적합기기로서 판매자 또는 사용자는 이 점을 주의하시기 바라며, 가정외의 지역에서 사용하는 것을 목적으로 합니다.

## ICES/NMB-001

This ISM device complies with Canadian ICES-001.

Cet appareil ISM est conforme à la norme NMB-001 du Canada.

# Instructions d'utilisation

Cet équipement est destiné à être utilisé par un personnel formé. L'utilisateur doit lire ce manuel d'instructions et toute autre information supplémentaire fournie par Agilent avant d'utiliser l'équipement. Agilent ne sera pas tenu responsable en cas d'événement se produisant en raison de la non-conformité à ces instructions, de l'utilisation inappropriée par des personnes non formées, de l'interférence non autorisée avec l'équipement ou de toute action contraire à ce qui est énoncé par les normes nationales spécifiques.

L'TS800 est une pompe à vide à spirales à sec. Cette pompe est adaptée au pompage de l'air ou des gaz inertes. La pompe n'est pas conçue pour pomper les gaz corrosifs, explosifs, ou à formation de particules.

Les paragraphes suivants comprennent toutes les informations nécessaires afin de garantir la sécurité de l'opérateur lors de l'utilisation de l'équipement. Des informations détaillées sont fournies dans le paragraphe « Technical Specifications » à la page 33.

Ce manuel utilise le protocole de sécurité standard suivant:

**AVERTISSEMENT** *Les messages d'avertissement ont pour but d'attirer l'attention de l'opérateur sur une procédure ou pratique particulière qui, si elle n'est pas correctement suivie, pourrait provoquer des blessures graves.*



**ATTENTION** *Les messages d'attention sont affichés avant les procédures, qui, si elles ne sont pas suivies, pourraient endommager l'équipement.*



**REMARQUE** *Les remarques contiennent les informations importantes prises du texte.*



## Conditionnement

Lors du transport et du conditionnement de la pompe, les exigences environnementales suivantes ne doivent pas être dépassées.

Température:  $-20\text{ °C}$  à  $+60\text{ °C}$  ( $-4\text{ °F}$  à  $140\text{ °F}$ )

Humidité relative: 0 à 95% (non-condensation)

## Préparation pour l'installation

La pompe est livrée dans un emballage protecteur spécial. Si elle manifeste des signes de dommages, qui peuvent s'être produits lors du transport, contactez votre bureau des ventes local.

Le poids total de l'emballage, pompe TS800 incluse, est d'environ 28,1 kg.

**AVERTISSEMENT** *La pompe TS800 elle-même pèse 32 kg. Pour éviter les blessures, utilisez les supports de levage et les techniques de levage appropriés lors du déplacement de la pompe.*



**AVERTISSEMENT** *Lorsque vous déballez la pompe, assurez-vous de ne pas la faire tomber et évitez tout genre d'impact soudain ou de vibration de choc dessus.*



**REMARQUE** *L'exposition normale à l'environnement ne peut endommager la pompe. Néanmoins, il est conseillé de garder le conduit d'entrée de la pompe fermé jusqu'à ce que la pompe soit installée dans le système.*





## Avertissements CEM

### Avertissement Classe A EN 55011

Il s'agit d'un produit de la Classe A. Dans un environnement domestique, ce produit peut causer une radio interférence, auquel cas l'utilisateur pourrait devoir prendre les mesures adéquates.

## FCC

Cet appareil est conforme à la Partie 15 des règles de la FCC. L'opération est sujette aux deux conditions suivantes : (1) ce dispositif ne provoque pas d'interférence nuisible, et (2) ce dispositif doit accepter toute interférence reçue, y compris l'interférence pouvant provoquer une opération indésirable.

### REMARQUE



*L'équipement a été testé et déclaré conforme aux limites d'un dispositif numérique de Classe A, selon la Partie 15 des règles de la FCC. Ces limites sont destinées à fournir une protection raisonnable contre l'interférence nuisible lorsque l'équipement est utilisé dans un environnement commercial. Cet équipement généré, utilise, et peut irradier une énergie à fréquence radio et, s'il n'est pas installé et utilisé conformément au manuel d'instructions, peut provoquer une interférence nuisible aux communications radio. L'utilisation de cet équipement dans une zone résidentielle est également susceptible de causer une interférence nuisible des communications radio.*

*Auquel cas, l'utilisateur devra corriger l'interférence à ses propres frais.*

## Installation

L'TS800 n'est PAS intrinsèquement sûre. Ne pas installer ou utiliser la pompe dans un environnement exposé à des agents atmosphériques (pluie, neige, glace), à la poussière, à des gaz nocifs, ou dans des environnements explosifs ou ceux présentant un risque élevé d'incendie.

Lors de l'opération, les conditions environnementales suivantes doivent être respectées:

Température: +5°C à +40°C (41°F à 104°F)

Humidité relative: 0 à 95% (non-condensation)

Raccordez la pompe au bloc d'alimentation en utilisant un câble électrique de style CEI-320 d'une capacité d'au moins 10 A.

### ATTENTION



*Lors de l'installation de la pompe à vide, il est recommandé que la pompe soit positionnée d'une manière à ce que l'interrupteur et le câble électrique restent facilement accessibles à l'utilisateur afin d'être disponibles en option pour couper rapidement l'alimentation de la pompe, si nécessaire.*

## Utilisation

Afin d'atteindre le vide maximal, la pompe doit être laissée en marche pendant au moins une heure avec le conduit d'entrée scellée.

Il n'existe aucune instruction spéciale pour le démarrage de la pompe, elle doit seulement être allumée en utilisant le commutateur On/Off.

La vanne d'admission en option s'ouvrira 30 secondes après le démarrage de la pompe.

**AVERTISSEMENT** *La pompe est conçue pour fonctionner avec des fluides neutres ou non corrosifs. Il est formellement interdit de l'utiliser avec des substances potentiellement explosives ou inflammables.*



Il n'existe aucune instruction spéciale pour l'arrêt de la pompe ; elle doit être seulement débranchée de la source électrique par l'interrupteur On/Off.

La vanne d'admission en option se fermera automatiquement après l'arrêt de la pompe.

## Entretien

Le personnel responsable de l'opération et de l'entretien de la pompe doit être bien formé et conscient des règles de prévention des accidents.

### AVERTISSEMENT



- *La mort peut résulter d'un contact avec des tensions élevées. Faites toujours extrêmement attention et respectez les réglementations de prévention des accidents en vigueur.*
- *Lorsque la machine est sous tension, faites attention aux pièces en mouvement et aux tensions élevées.*
- *Si vous devez effectuer un entretien sur la pompe après un temps considérable d'utilisation, laissez-la refroidir car la température de la surface extérieure peut dépasser les 60°C.*
- *Débranchez toujours votre bloc d'alimentation de la pompe avant de commencer le travail d'entretien.*

### REMARQUE



*Avant de retourner la pompe à l'usine pour réparation, la feuille " Santé et Sécurité " jointe à ce manuel d'instructions doit être remplie et envoyée au bureau des ventes local. Une copie de la feuille doit être insérée dans l'emballage de la pompe avant l'expédition.*

Si une pompe doit être mise au rebut, elle doit être jetée conformément aux normes nationales spécifiques.

## Mise au rebut

Signification du logo *WEEE* figurant sur les étiquettes.

Le symbole ci-dessous est appliqué conformément à la directive CE nommée "WEEE". Ce symbole (uniquement valide pour les pays de la Communauté européenne) indique que le produit sur lequel il est appliqué NE doit PAS être mis au rebut avec les ordures ménagères ou les déchets industriels ordinaires, mais passer par un système de collecte sélective.

Après avoir vérifié les termes et conditions du contrat de vente, l'utilisateur final est donc prié de contacter le fournisseur du dispositif, maison mère ou revendeur, pour mettre en œuvre le processus de collecte et mise au rebut.



Pour en savoir plus, consulter:

# Instrucciones de Uso

## Información general

Este equipo está diseñado para ser usado por personal capacitado. Antes de utilizar el equipo el usuario debe leer este manual de instrucciones, así como cualquier otra información adicional proporcionada por Agilent. Agilent no se hará responsable de ninguna situación que se produzca debido al incumplimiento de estas instrucciones, el uso incorrecto por parte de personas sin formación, modificación no autorizada del equipo o cualquier acción contraria a las aprobadas por las normas nacionales específicas.

La TS800 es una bomba de vacío scroll seca. Esta bomba es adecuada para bombear aire o gases inertes. En cambio, no ha sido diseñada para bombear gases corrosivos, explosivos o que formen partículas.

Los siguientes párrafos contienen toda la información necesaria para garantizar la seguridad del operador cuando utilice el equipo. Encontrará información detallada en "Technical Specifications" en la página 33.

Este manual utiliza el siguiente protocolo estándar de seguridad:

**ADVERTENCIA** *Los mensajes de advertencia sirven para atraer la atención del usuario hacia un procedimiento o práctica en particular; el cual, en caso de no seguirse correctamente, podría producir lesiones graves.*



**PRECAUCIÓN** *Los mensajes de precaución se muestran antes de los procedimientos, si no se siguen, se podría provocar daños al equipo.*



**NOTA** *Las notas contienen información importante tomada del texto.*



## Almacenamiento

No deberían excederse los siguientes requerimientos ambientales al transportar o almacenar la bomba:

Temperatura:  $-20\text{ }^{\circ}\text{C}$  a  $+60\text{ }^{\circ}\text{C}$  ( $-4\text{ }^{\circ}\text{F}$  a  $140\text{ }^{\circ}\text{F}$ )

Humedad relativa: de 0% a 95%, (sin condensación)

## Preparación de la Instalación

La bomba se suministra con un embalaje protector especial. Si este embalaje muestra signos de haber sido dañado, lo cual podría ocurrir durante el transporte, contacte con su oficina local de ventas.

El peso total del embalaje, incluyendo la bomba TS800, es de aproximadamente 42 kg (93 lbs).

**ADVERTENCIA** *La bomba TS800 pesa 32 kg (71 lbs). Para evitar lesiones, utilice las técnicas adecuadas para levantar pesos al mover la bomba.*



**ADVERTENCIA** *Al desembalar la bomba, asegúrese de no dejarla caer y evite cualquier clase de impacto abrupto, choque o vibración a la misma.*



**NOTA** *La exposición normal al entorno no puede dañar la bomba. No obstante, se recomienda mantener cerrada la entrada de la bomba hasta que la bomba sea instalada en el sistema.*



## Advertencias EMC

### Advertencia Clase A EN 55011

Este es un producto de clase A. En un entorno doméstico, este producto puede causar interferencias de radio; en tal caso es posible que el usuario deba tomar las medidas adecuadas.

## FCC

Este dispositivo cumple con la parte 15 de las normas de la FCC. Su funcionamiento está sujeto a las dos condiciones siguientes: (1) Este dispositivo no debe causar ninguna interferencia perjudicial, y (2) este dispositivo debe aceptar cualquier interferencia recibida, incluida cualquier interferencia que puedan provocar un funcionamiento indeseable.

### NOTA



*El equipo ha sido probado y se ha demostrado que cumple con los límites correspondientes a un dispositivo digital de clase A, de acuerdo con la parte 15 de las normas de la FCC. Estos límites están destinados a brindar protección razonable contra interferencias perjudiciales, cuando el equipo funciona en un entorno comercial. Este equipo genera, utiliza y puede irradiar energía de radiofrecuencia y, si no se instala y utiliza de acuerdo con el manual de instrucciones, puede provocar interferencias perjudiciales en las comunicaciones de radio. El uso de este equipo en un área residencial también puede provocar interferencias perjudiciales en las comunicaciones de radio, en cuyo caso el usuario debe hacerse cargo de los costos derivados de corregir dichas interferencias.*

## Instalación

La TS800 *NO* es intrínsecamente segura. No instale o use la bomba en un entorno expuesto a agentes atmosféricos (lluvia, nieve, hielo), polvo, gases agresivos o en entornos explosivos o aquellos con un alto riesgo de incendio.

Durante el funcionamiento, se deben respetar las siguientes condiciones ambientales:

Temperatura: +5 °C a +40 °C (41 °F a 104 °F)

Humedad relativa: 0% a 95%, (sin condensación)

Conecte la bomba a la fuente de alimentación utilizando un cable tipo IEC-320 con una capacidad mínima de 10 A (consulte Tabla 1 en la página 27).

**PRECAUCIÓN** *Al instalar la bomba de vacío se recomienda posicionarla de forma que el interruptor de energía y el cable de alimentación sean fácilmente accesibles para el usuario en caso de que deba desconectar rápidamente la energía de la bomba.*



## Uso

Con el fin de alcanzar el vacío máximo, la bomba debe dejarse funcionando por lo menos durante una hora con la entrada sellada.

No hay instrucciones especiales para poner en marcha la bomba, solamente se debe encender utilizando el interruptor de encendido y apagado (On/Off).

La válvula de entrada opcional se abrirá 30 segundos después de que se inicie la bomba.

**ADVERTENCIA** *La bomba ha sido diseñada para funcionar con fluidos neutros no corrosivos. Está terminantemente prohibido utilizarla con sustancias potencialmente explosivas o inflamables.*



No hay instrucciones especiales para detener la bomba, solamente debe ser desconectada de la fuente de alimentación utilizando el interruptor de encendido y apagado (On/Off).

La válvula de entrada opcional se cerrará inmediatamente después de que la bomba se detenga.

## Mantenimiento

El personal responsable del funcionamiento y mantenimiento de la bomba debe tener una buena formación y conocer las normas de prevención de accidentes.

- ADVERTENCIA**
- *El contacto con alta tensión puede ser fatal. Siempre tenga mucho cuidado y observe las normas vigentes en materia de prevención de accidentes.*
  - *Al encender la bomba, tenga cuidado con las partes en movimiento y la alta tensión.*
  - *Si tiene que realizar el mantenimiento de la bomba después de haber estado funcionando durante un tiempo considerable, déjela que se enfríe, dado que la temperatura de la superficie exterior puede superar los 60 °C.*
  - *Siempre desconecte la fuente de alimentación de la bomba antes de comenzar el mantenimiento.*



### NOTA



*Antes de devolver la bomba a la fábrica para su reparación, debe completar la hoja "Solicitud de devolución" que se adjunta a este manual de instrucciones y enviarla a la oficina local de ventas. Debe incluir una copia de la hoja en el embalaje de la bomba antes de despacharla.*

Si la bomba debe desecharse, habrá que proceder de acuerdo con las normas nacionales específicas.

### Eliminación

Significado del logotipo WEEE que aparece en las etiquetas.

El siguiente símbolo se aplica de acuerdo con la Directiva WEEE (Residuos de Aparatos Eléctricos y Electrónicos [RAEE]) de la CE. Este símbolo (válido sólo en los países de la Comunidad Europea) indica que el producto en cuestión NO debe eliminarse junto con la basura doméstica o industrial ordinaria, sino que debe ser enviado a un sistema de recolección diferenciada.

Por lo tanto, se invita al usuario final a ponerse en contacto con el proveedor del dispositivo, sea la casa matriz o un minorista, para iniciar el proceso de recolección y eliminación después de comprobar los términos y condiciones del contrato de venta.



# Istruzioni per l'uso

Questa apparecchiatura è destinata all'uso da parte di personale formato. L'utente deve leggere il presente manuale di istruzioni ed eventuali informazioni aggiuntive fornite da Agilent prima di utilizzare l'apparecchiatura. Agilent non è responsabile per qualsiasi evento che si verifichi in seguito al mancato rispetto di queste istruzioni, all'uso improprio da parte di persone non formate, all'interferenza non autorizzata con l'apparecchiatura, o a qualsiasi azione contraria a quanto dichiarato nelle norme nazionali specifiche.

La TS800 è una pompa per vuoto a secco. Questa pompa è adatta per il pompaggio di aria o gas inerti. La pompa non è progettata per pompare gas corrosivi, esplosivi o formati da particelle.

I seguenti paragrafi contengono tutte le informazioni necessarie per garantire la sicurezza dell'operatore durante l'utilizzo dell'apparecchiatura. Informazioni dettagliate sono fornite nel paragrafo "Technical Specifications" a pagina 33.

Questo manuale utilizza il seguente protocollo di sicurezza standard:

## AVVERTENZA



*Lo scopo dei messaggi di avvertimento è quello di attirare l'attenzione dell'operatore su una particolare procedura o pratica che, se non correttamente seguita, potrebbe causare gravi lesioni.*

## ATTENZIONE



*I messaggi di attenzione vengono visualizzati prima delle procedure che, se non vengono seguite, potrebbero danneggiare l'apparecchiatura.*

## NOTA



*Le osservazioni contengono importanti informazioni tratte dal testo.*

## Imballaggio

Durante il trasporto e l'imballaggio della pompa non devono essere superati i seguenti requisiti ambientali.

Temperatura:  $-20\text{ }^{\circ}\text{C}$  a  $+60\text{ }^{\circ}\text{C}$  ( $-4\text{ }^{\circ}\text{F}$  a  $140\text{ }^{\circ}\text{F}$ )

Umidità relativa: 0 a 95% (non condensata)

## Preparazione per l'installazione

La pompa viene fornita in uno speciale imballaggio protettivo. Se mostra segni di danni, che possono essersi verificati durante il trasporto, contattare l'ufficio vendite locale.

Il peso totale dell'imballaggio, pompa TS800 inclusa, è di circa 28,1 kg

### PERICOLO



*La pompa TS800 pesa 32 kg. Per evitare lesioni, utilizzare i supporti di sollevamento e le tecniche di sollevamento appropriate nello spostare la pompa.*

### PERICOLO



*Quando si disimballa la pompa, assicurarsi di non farla cadere ed evitare qualsiasi tipo di impatto improvviso o vibrazione d'urto su di essa.*

### NOTA



*La normale esposizione all'ambiente non può danneggiare la pompa. Tuttavia, è consigliabile tenere chiusa la linea di ingresso della pompa fino a quando la pompa non viene installata nell'impianto.*

## Avvertenze CEM

### Avvertenza Classe A EN 55011

Questo è un prodotto di Classe A. In un ambiente domestico, questo prodotto può causare interferenze radio, nel qual caso l'utente può essere tenuto ad adottare misure adeguate.

## FCC

Questo dispositivo è conforme alla Parte 15 delle normative FCC. L'operazione è soggetta alle seguenti due condizioni: (1) questo dispositivo non deve causare interferenze dannose, e (2) questo dispositivo deve accettare qualsiasi interferenza ricevuta, incluse le interferenze che possono causare un funzionamento indesiderato.

### NOTA



*L'apparecchiatura è stata testata e trovata conforme ai limiti per un dispositivo digitale di Classe A, ai sensi della Parte 15 delle normative FCC. Questi limiti sono progettati per fornire una protezione ragionevole contro le interferenze dannose quando l'apparecchiatura viene utilizzata in un ambiente commerciale.*

*Questa apparecchiatura genera, utilizza e può irradiare energia a radiofrequenza e, se non installata e utilizzata in conformità con il manuale di istruzioni, può causare interferenze dannose alle comunicazioni radio. Il funzionamento di questa apparecchiatura in un'area residenziale può anche causare interferenze dannose alle comunicazioni radio.*

*In tal caso, l'utente è tenuto a correggere l'interferenza a proprie spese.*



## Installazione

La TS800 NON è intrinsecamente sicura. Non installare o utilizzare la pompa in un ambiente esposto ad agenti atmosferici (pioggia, neve, ghiaccio), polvere, gas nocivi, o in ambienti esplosivi o ad alto rischio di incendio.

Durante il funzionamento devono essere rispettate le seguenti condizioni ambientali:

Temperatura: da +5 °C a +40 °C (da 41 °F a 104 °F)

Umidità relativa: 0 a 95% (non condensata)

Collegare la pompa all'alimentazione elettrica utilizzando un cavo di alimentazione di tipo IEC-320 con una capacità di almeno 10 A.

### ATTENZIONE



*Quando si installa la pompa per vuoto, si raccomanda che la pompa sia posizionata in modo tale che l'interruttore e il cavo elettrico rimangano facilmente accessibili all'utente, in modo da poter essere eventualmente disponibili per interrompere rapidamente l'alimentazione elettrica alla pompa, se necessario.*

## Utilizzo

Per raggiungere il vuoto massimo, la pompa deve essere lasciata in funzione per almeno un'ora con il condotto di aspirazione sigillato.

Non ci sono istruzioni speciali per l'avviamento della pompa, deve essere semplicemente accesa tramite l'interruttore On/Off.

La valvola di ingresso opzionale si aprirà 30 secondi dopo l'avviamento della pompa.

### PERICOLO



*La pompa è progettata per funzionare con fluidi neutri o non corrosivi. È severamente vietato l'uso con sostanze potenzialmente esplosive o infiammabili.*

Non ci sono istruzioni speciali per l'arresto della pompa, deve essere semplicemente spenta tramite l'interruttore On/Off.

La valvola di ingresso opzionale si chiuderà automaticamente dopo l'arresto della pompa.

## Manutenzione

Il personale responsabile del funzionamento e della manutenzione della pompa deve essere ben formato e consapevole delle norme di prevenzione degli incidenti.

### AVVERTENZA



- *Il contatto con tensioni elevate può causare il decesso. Prestare sempre la massima attenzione e rispettare le norme antinfortunistiche vigenti.*
- *Quando la macchina è sotto tensione, fare attenzione alle parti in movimento e alle tensioni elevate.*
- *Se è necessario effettuare la manutenzione della pompa dopo un ragionevole periodo di utilizzo, lasciarla raffreddare, poiché la temperatura della superficie esterna può superare i 60 °C.*
- *Scollegare sempre l'alimentatore dalla pompa prima di iniziare i lavori di manutenzione.*

### NOTA



*Prima di restituire la pompa alla fabbrica per effettuare la riparazione, è necessario compilare il foglio "Salute e sicurezza" allegato al presente manuale di istruzioni e inviarlo all'ufficio vendite locale. Una copia del foglio deve essere inserita nell'imballaggio della pompa prima della spedizione.*

Se una pompa deve essere smaltita, è necessario farlo seguendo le norme nazionali specifiche.

## Smaltimento

Significato del logo *RAEE* sulle etichette.

Il simbolo sottostante è applicato in conformità alla direttiva CE denominata "RAEE". Questo simbolo (valido solo per i Paesi della Comunità europea) indica che il prodotto a cui è applicato NON deve essere smaltito con i normali rifiuti domestici o industriali, ma attraverso un sistema di raccolta differenziata.

Dopo aver verificato i termini e le condizioni del contratto di vendita, l'utente finale è quindi invitato a contattare il fornitore del dispositivo, la società madre o il rivenditore, per attuare il processo di raccolta e smaltimento.



Per ulteriori informazioni, consultare:

# Anwendungshinweise

Dieses Gerät wurde für die Benutzung durch geschultes Personal entwickelt. Die Bedienperson muss vor der Verwendung des Geräts diese Bedienungsanleitung sowie alle weiteren Zusatzinformationen von Agilent lesen. Agilent übernimmt keine Verantwortung für Ereignisse, die aufgrund der Nichtbeachtung dieser Anweisungen und der falschen Benutzung durch ungeschulte Personen sowie aufgrund von nicht autorisierten Interferenzen mit dem Gerät oder von Handlungen eintreten, die den festgelegten nationalen Normen widersprechen.

Die TS800 ist eine Vakuum-Scrollpumpe. Diese Pumpe eignet sich für das Pumpen von Luft oder Inertgas. Die Pumpe wurde nicht zum Pumpen von korrosiven, explosiven oder mit Partikeln durchsetzten Gasen entwickelt.

Die folgenden Abschnitte enthalten alle erforderlichen Informationen, um die Sicherheit der Bedienperson beim Umgang mit dem Gerät zu gewährleisten. Detaillierte Informationen befinden sich im Abschnitt « Technical Specifications » auf Seite 33.

In diesem Handbuch kommen die folgenden Sicherheitsstandards zur Anwendung:

## GEFAHR



*Warnhinweise dienen dazu, die Aufmerksamkeit der Bedienperson auf ein bestimmtes Verfahren oder eine bestimmte Maßnahme zu lenken; wird dies nicht korrekt befolgt, kann es zu schweren Verletzungen kommen.*

## ACHTUNG



*Vorsichtshinweise werden vor Verfahren angezeigt, die bei Nichtbeachtung zu Schäden am Gerät führen können.*

## ANMERKUNG



*Anmerkungen enthalten wichtige Informationen aus dem Text.*

## Lagerung

Bei Transport und Lagerung der Pumpe dürfen die folgenden Umgebungsbedingungen nicht ignoriert werden.

Temperatur:  $-20^{\circ}\text{C}$  bis  $+60^{\circ}\text{C}$  ( $4^{\circ}\text{F}$  bis  $140^{\circ}\text{F}$ )  
Relative Luftfeuchtigkeit: 0 bis 95 % (nicht kondensierend)

## Vorbereitung auf die Installation

Die Pumpe wird in einer speziellen Schutzverpackung geliefert. Weist diese Anzeichen von Schäden auf, die während des Transports aufgetreten sein könnten, wenden Sie sich bitte an Ihren lokalen Händler.

Das Gesamtgewicht der Verpackung inklusive der Pumpe TS800 beträgt etwa 28,1 kg.

## GEFAHR



*Die Pumpe TS800 allein wiegt 32 kg. Um Verletzungen zu vermeiden, verwenden Sie beim Bewegen der Pumpe Hebewerkzeug und entsprechende Hebetekniken.*

## GEFAHR



*Achten Sie beim Auspacken der Pumpe darauf, sie nicht fallen zu lassen, und vermeiden Sie auf die Pumpe einwirkende Stöße und Vibrationen.*

## ANMERKUNG



*Normale Umgebungsbedingungen können die Pumpe nicht beschädigen. Es wird dennoch empfohlen, den Pumpeneinlass geschlossen zu halten, bis die Pumpe im System installiert wird.*

## Hinweise zur elektromagnetischen Verträglichkeit

### Hinweis Klasse A, EN 55011

Es handelt sich um ein Produkt der Klasse A. In einem Wohnumfeld kann dieses Produkt Interferenzen verursachen; in diesem Fall muss der Benutzer entsprechende Maßnahmen treffen.

## FCC

Dieses Gerät entspricht den Anforderungen gemäß Teil 15 der FCC-Bestimmungen. Beim Betrieb müssen die folgenden Bedingungen eingehalten werden: (1) Dieses Gerät darf keine schädlichen Interferenzen verursachen und (2) Dieses Gerät muss empfangene Interferenzen aufnehmen, einschließlich Störungen, die zu einem unerwünschten Betrieb führen können.

### ANMERKUNG



*Das Gerät wurde getestet und gemäß Teil 15 der FCC-Bestimmungen als digitales Gerät der Klasse A klassifiziert. Diese Grenzen dienen dazu, beim Betrieb des Geräts in einem gewerblichen Umfeld einen ausreichenden Schutz vor schädlichen Interferenzen zu bieten. Dieses Gerät erzeugt, verbraucht und kann Hochfrequenzenergie abstrahlen. Wird das Gerät nicht in Übereinstimmung mit der Bedienungsanleitung installiert und verwendet, können Funkstörungen auftreten. Der Betrieb dieses Geräts in Wohngebieten kann auch Funkstörungen verursachen.*

*In diesem Fall muss der Benutzer diese Funkstörungen auf seine eigenen Kosten beheben.*

## Installation

Die TS800 ist NICHT eigensicher. Installieren und verwenden Sie die Pumpe nicht in einer Umgebung, die dem Wetter (Regen, Schnee, Frost), Staub oder schädlichen Gasen ausgesetzt ist, sowie in einer explosiven Umgebung oder einer Umgebung mit hoher Brandgefahr.

Beim Betrieb müssen die folgenden Umgebungsbedingungen eingehalten werden:

Temperatur: +5 °C bis +40 °C (41 °F bis 104 °F)  
Relative Luftfeuchtigkeit: 0 bis 95 % (nicht kondensierend)

Schließen Sie die Pumpe über ein Stromkabel vom Typ IEC-320 mit einer Kapazität von zumindest 10 A an das Netzteil an.

### ACHTUNG



*Bei der Installation der Vakuumpumpe wird empfohlen, die Pumpe so zu positionieren, dass der Netzschalter und das Stromkabel für die Bedienperson einfach zu erreichen sind, um die Versorgung der Pumpe bei Bedarf rasch unterbrechen zu können.*

## Betrieb

Um das maximale Vakuum zu erreichen, muss die Pumpe zumindest eine Stunde lang bei versiegeltem Einlass laufen.

Für den Start der Pumpe gibt es keine besonderen Anweisungen; sie muss nur über den Ein/Aus-Netzschalter eingeschaltet werden.

Das optionale Einlassventil öffnet sich 30 Sekunden nach dem Starten der Pumpe.

### GEFAHR



*Die Pumpe wurde für den Betrieb mit neutralen oder nicht korrosiven Flüssigkeiten entwickelt. Es ist strengstens untersagt, sie mit potenziell explosiven oder entzündlichen Substanzen in Betrieb zu nehmen.*

Für das Ausschalten der Pumpe gibt es keine besonderen Anweisungen; sie muss nur über den Ein/Aus-Netzschalter ausgeschaltet werden.

Das optionale Einlassventil schließt sich nach dem Ausschalten der Pumpe automatisch.

## Wartung

Das Bedien- und Wartungspersonal für die Pumpe muss gut geschult werden und die Regeln zur Vermeidung von Unfällen kennen.

### GEFAHR



- *Ein Kontakt mit Hochspannung kann zum Tod führen. Gehen Sie stets vorsichtig vor und befolgen Sie die geltenden Regeln zur Vermeidung von Unfällen.*
- *Achten Sie auf bewegliche Teile und Hochspannung, während das Gerät unter Spannung steht.*
- *Müssen Sie nach längerem Betrieb der Pumpe eine Wartung durchführen, lassen Sie sie abkühlen, da die Oberflächentemperatur 60 °C überschreiten kann.*
- *Trennen Sie vor Wartungsarbeiten stets die Versorgung der Pumpe.*

### ANMERKUNG



*Vor dem Versand der Pumpe für eine Reparatur im Werk muss das Formular „Gesundheit und Sicherheit“, das diesem Handbuch beiliegt, ausgefüllt und dem lokalen Händler gesendet werden. Eine Kopie des Formulars muss der Pumpe beim Versand beigelegt werden.*

Muss die Pumpe entsorgt werden, sind die speziellen nationalen Bestimmungen zu befolgen.

## Entsorgung

Bedeutung des Logos *WEEE* auf den Aufklebern.

Das nachfolgende Symbol wird in Übereinstimmung mit der CE-Norm mit dem Namen „WEEE“ verwendet. Dieses Symbol (das nur für EU-Staaten gilt) weist darauf hin, dass das Produkt, auf dem es sich befindet, NICHT im Restmüll oder Industrieabfall, sondern getrennt zu entsorgen ist.

Nach Durchsicht der allgemeinen Geschäftsbestimmungen im Kaufvertrag wird der Endbenutzer deshalb gebeten, sich an den Händler des Geräts (Hauptsitz oder Vertriebspartner) zu wenden, um die getrennte Entsorgung anzustoßen.



Weitere Informationen dazu finden Sie unter:

# 使用上の注意

## 一般情報

本機器は、トレーニングを受けた作業員の使用を想定して設計されています。機器を使用する前に、本取扱説明書および Agilent が提供するその他の追加情報を必ずお読みください。Agilent は、これらの指示の不履行、トレーニングを受けた作業員以外による不適切な使用、認められていない機器の改造、もしくは所定の国内規格に反する行為により発生した事故等には責任を負いかねます。

TS800 は、スクロール型ドライ真空ポンプです。このポンプは、空気または不活性ガスの排気に適しています。ポンプは、腐食性ガス、爆発性ガス、または粒子生成ガスにはお使いいただけません。

以下の段落には、機器を使用する作業員の安全を保証するために必要なあらゆる情報が記載されています。詳細は、33?????Technical Specifications? をご覧ください。

本説明書では、以下の標準安全プロトコルを使用します。



警告メッセージは、正しく従わなかった場合に重大なケガにつながる特定の手順または行為に作業員の注意を向けさせるためのものです。



注意メッセージは、従わなかった場合に機器の損傷を招く恐れがある手順の前に表示されます。



メモには、本文に記載されている重要な情報が含まれます。

## 保管

ポンプの輸送および保管の際には、以下の環境条件に必ず従ってください。

温度： -20 ° C ~ 60 ° C (-4 ° F ~ 140 ° F)

相対湿度： 0 ~ 95% (結露なし)

## 設置準備

ポンプは、特殊保護包装でお届けします。包装に輸送中に発生したらしき損傷の形跡がある場合、最寄りの営業所にご連絡ください。

TS800 を含めた包装の総重量は、およそ 42 kg (93 lbs) です。



TS800 ポンプの本体重量は 32 kg (71 lbs) です。ケガ防止のため、ポンプを動かすときはリフト補助具を使用し、適切なやり方で持ち上げてください。



ポンプを開梱する際は、落とさないように注意し、衝撃や強い振動を与えないようにしてください。



通常的环境下で、ポンプが損傷することはありませんが、システムにポンプを設置し終わるまでは、ポンプの吸気口を閉じたままにしておくことをお勧めします。

## EMC 警告

### EN 55011 クラス A 警告

本製品はクラス A 製品です。本製品は屋内環境で電波障害を発生させる恐れがあり、適切な対策が必要になる場合があります。

## FCC

本機器は FCC Part 15 に準拠しています。本機器の動作は、次の二つの条件を満たす必要があります：(1) 本機器は、有害なノイズを発生させない。(2) 本機器は、望ましくない動作を引き起こす可能性のあるノイズも含め、受信したいかなるノイズにも耐えうるものでなければならない。

### 注



本機器はテストの結果、FCC 規制パート 15 によるクラス A デジタル製品の制限に準拠していることが証明されています。これらの制限は、商業環境で機器を使用した場合に、有害なノイズに対して合理的な保護を提供するために設けられています。本機器は、電波エネルギーを発生、使用、および放射する可能性があり、取扱説明書に従って設置および使用しない場合は無線通信に有害な干渉を起こす恐れがあります。住居地域で本機器を使用すると、電波通信に無線通信に有害な干渉を引き起こす可能性があり、その場合は使用者が費用を負担して干渉を防止する対策を講じることを求められます。



## 設置

TS800 は、本質安全防爆仕様ではありません。大気中物質（雨、雪、氷）、塵、刺激性ガスにさらされる環境、または爆発が起こる可能性のある環境、または火災の危険性が大きい環境で、ポンプを設置または使用しないでください。

運転中は、以下の環境条件に必ず従ってください。

温度： +5 ° C ~ +40 ° C (41 ° F ~ 104 ° F)

相対湿度： 0 ~ 95%（結露なし）

ポンプは、容量が 10 A 以上の IEC-320 スタイル電源コードを使用して電源に接続してください（27?????1を参照）。

### 注意



真空ポンプを設置する際は、必要に応じて直ちにポンプの電源を遮断できるようにするため、電源スイッチと電源コード接続に使用者が常に簡単にアクセスできるように配置することをお勧めします。

## 使用

最大の真空度を得るには、吸気口を密閉した状態で 1 時間以上ポンプを運転する必要があります。

ポンプの運転を開始するための特別な手順はありません。オン / オフスイッチを使用してスイッチを入れるだけです。

ポンプの運転を開始すると、オプションの吸気弁が 30 秒後に開きます。

### 警告



ポンプは、中性流体または非腐食性流体を使用した運転を想定しています。爆発や燃える恐れのある物質は、絶対に使用しないでください。

ポンプの運転を停止するための特別な手順はありません。オン / オフスイッチを使用して電源を切るだけです。

ポンプの運転を停止すると、オプションの吸気弁がすぐに閉じます。

## メンテナンス

ポンプの操作およびメンテナンスは、十分なトレーニングを受け、事故防止規則を認識している作業員が担当してください。

### 警告



- 接触高?可能会?致死亡。始?格外小心并遵守?行的事故?防?定
- 机器通?后, ?注意不要移?部件和施加高?。
- 如果在相当?的运行??后必????行??, ?冷却?, 因?其外表面温度可能超?60° C
- 在?始??工作之前, ??必断??的?源。

### 注



修理のためにポンプを工場に返送する前に、本取扱説明書に付属の「返送依頼書 (Request for Return)」に必要事項を記入し、最寄りの営業所にお送りください。ポンプを発送する前に、ポンプの梱包に依頼書のコピーを必ず入れてください。

ポンプを処分する場合、所定の国内規格に従って廃棄する必要があります。

### 廃棄

ラベルに記載されている WEEE ロゴの意味。

以下の記号は、EC WEEE（電気電子廃棄物）指令に準拠して適用されます。この記号（欧州共同体加盟国のみで有効）は、この記号が記載されている製品を通常の家ごみまたは産業廃棄物と一緒に廃棄することはできず、専用の収集システムに送る必要があることを示しています。

したがって、エンドユーザーは、収集および廃棄処理を開始するために、契約条項および販売条件を確認した後で、親会社であるか小売業者であるかを問わず、機器の供給業者に連絡することが求められます。



詳細はこちらをご覧ください。:

# 使用说明

本设备仅供专业人士使用。用户应在使用设备前阅读本说明以及安捷伦提供的额外信息。如因未遵守说明或非专业人士的不当使用、未经授权的设备干扰或任何违背国家标准规定而造成事故，安捷伦概不负责。

TS800为涡旋型干式真空泵。该泵适用于泵送空气或惰性气体。该泵不适用于泵送腐蚀性、爆炸性气体或微粒物。

以下段落将介绍使用设备时确保操作员安全所需的所有信息。中的“技术信息”段落中提供了详细信息。

本手册遵循以下标准安全协议：

警告



该警告旨在要求操作员注意特定的程序或操作方法，如果操作不当，可能会造成严重伤害。

注意



警告信息会在操作之前提示。如不遵循，可能导致设备损坏。

注释



注释内容包含文本中的重要信息。

# 包装

泵的运输和包装过程不得违反以下环境要求。

温度： -20 °C 至 +60 °C (-4 °F 至 140 °F)

相对湿度： 0 至 95% (非冷凝处理)

## 安装准备

泵的产品原包装为防护型特殊包装。如包装在运输过程中出现破损，请与当地销售办事处联系。

包装总重量（包括TS800 泵在内）约为 28.1kg。

警告



TS800 泵自重为 32kg。为避免受伤，在移动泵时，请选用合适的起重支撑件和起重方式。

警告



打开泵的包装时，请避免泵体掉落，并避免造成任何突然的撞击或震动。

注释



正常环境暴露不会对泵造成损伤。建议将泵进口管保持关闭状态，直至安装完毕。

## CEM 警告

### 警告等级 A EN 55011

该设备属于 A 类产品。在家用环境中，该设备可能会造成无线电干扰。用户需为此采取适当的措施。

## 美国联邦通信委员会（FCC）

该设备符合 FCC 法规第 15 部分。操作必须满足以下两个条件：（1）该设备不会造成有害干扰，且（2）该设备必须接收任何干扰，包括可能影响正常运行的干扰。

注释



*该设备已通过测试，并根据 FCC 法规第 15 部分规定符合 A 类数字设备的限制。该限制旨在为在商业环境中操作设备提供合理的保护，以防有害干扰。本设备可以产生、利用并发射无线射频能量，如果不按照说明中的要求安装和使用本设备，有可能对无线电通信造成有害干扰。在居民区使用此设备可能对无线电通信造成有害干扰。*

*据此情况，用户必须自行消除干扰。*

# 安装

TS800 并不具备固有安全性。请勿将泵暴露在大气介质（雨、雪、冰）、灰尘、有害气体的环境中，请勿在易燃易爆区或具有高火灾危险的环境中安装或使用泵。

在操作过程中，须遵守以下环境条件：

温度： +5°C 至 +40°C （41°F 至 104°F）

相对湿度： 0 至 95% （非冷凝处理）

使用容量至少为 10A 的 CEI-320 型电缆将电源连接至泵。

注意



在安装真空泵时，建议将其置于在适当的位置，以使用户方便地操作开关和电缆。如必要时，可迅速切断电源。

# 用途

为达到最低真空度，必须使泵在进口管密封状态运转一小时以上。

如需启动泵，无需其他特殊操作，只需使用“On/Off”开关即可。

启动泵后，可选入口阀将在 30 秒后自动开启。

警告



该泵设计用于中性或非腐蚀性流体。  
严禁将其与易燃易爆物质同时使用。

如需关闭泵，没有其他特殊操作，只需使用“On/Off”开关即可切断电源连接。

泵停止后，可选入口阀将自动关闭。

## 维护

负责泵体操作和维护的人员必须已接受良好的培训，并了解事故预防规定。

警告



q 直接接触高压可能导致死亡。应始终保持谨慎，并严格遵守事故预防规定。

q 设备运转时，请小心移动部件和高压。

q 如需在较长使用时间后对泵进行维护，需待泵冷却后再进行操作。泵q体外表面温度可能会超过60°C。

在开始维护工作之前，请断开电源。

注释



在将泵送回工厂维修前，须填写本说明书手册随附的“健康与安全”表格，并寄给当地销售办事处。寄送回厂前，须将表格的复印件放入泵的包装中。

如须丢弃泵，则必须按照国家特殊标准进行处理。

## 废料处理

标签上 WEEE 标识的含义

以下为根据 CE 指令《废弃电子电气设备指令》应用的标识。此标识（仅在欧共体国家适用）表示应用该产品不应与生活垃圾或普通工业废物一起处理，而必须通过具备选择性回收系统处理。

因此，在确认销售合同条款后，用户应与设备供应商、母公司或转售商联系，以进行回收和处理。



如欲了解更多内容，请登录我们的网站：

## Power Cord

Several power cord options are available from your Agilent dealer. Descriptions of the available power cords and their ordering numbers are given in Table 1.

### NOTE



*The pump must be connected to the power supply using a high voltage IEC-320 type power cord of at least 10 A capacity.*

**Table 1 Power Cord Selection**

Country	Power Cord Specification	Order
Europe	10 A / 220-230 VAC, 2.5 m	656494220
Denmark	10 A / 220-230 VAC, 2.5 m	656494225
Switzerland	10 A / 230 VAC, 2.5 m	656494235
UK/Ireland	13 A / 230 VAC, 2.5 m	656494250
India	10 A / 220-250 VAC, 2.5 m	656494245
Israel	10 A / 230 VAC, 2.5 m	656494230
North America	10 A / 230 VAC, 2.5 m	656494255

## Grounding Instructions

This product should be grounded. In the event of an electrical short circuit, grounding reduces the risk of electric shock by providing an escape wire for the electric current. This pump is equipped with a power cord that has a grounding wire with an appropriate grounding plug. The plug must be inserted into an outlet that is properly installed and grounded in accordance with all local codes and ordinances.

### WARNING



*Check with a qualified electrician or serviceman if the grounding instructions are not completely understood, or if you are in doubt as to whether the product is properly grounded.*

*Do not modify the plug provided; if it does not fit the outlet, have the proper outlet installed by a qualified electrician.*

*Connect the product only to an outlet that has the same configuration as the plug.*

*Do not use an adapter with this product.*

## Extension Cords

If you must use an extension cord with this product:

- Agilent recommends using only extension cords with a minimum of 16-gauge wire and a maximum length of 25' (7.6 m).
- Use only a 3-wire extension cord that accepts the plug.
- Ensure the extension is in good condition.
- Ensure the extension cord is rated high enough to carry the current the products draws. An undersized cord causes a drop in line voltage, resulting in loss of power and overheating.

## Circuit Breakers

### WARNING



- *Protect against short circuits by installing a circuit breaker of the proper capacity.*
- *The circuit breaker must be suitably located and easily reached.*
- *The circuit breaker must be marked at the disconnecting device for the equipment with the on/off symbol I/O and meet the relevant requirements of IEC60947-1 and IEC60947-3.*

Table 2 lists the circuit breaker capacity required for the pump. Locate the switch or circuit breaker near the pump.

**Table 2 Circuit Breaker Requirements**

PTS08001INV	200-240 VAC 50/60 Hz
Breaker capacity	10 Amperes

## Mechanical Connections

### Pump Location

Locate the pump on a firm, level surface.

Clearance mounting holes provided in the frame can be used to provide permanent attachment. Attach the provided rubber mounts to the threaded holes at the frame base to minimize vibration.

Do not position the equipment so that it is difficult to operate the disconnecting device.

### Vacuum Pump Isolation Valve

Scroll pumps return to atmospheric pressure quickly when shut off. Thus, an integrated fast acting, automatic, normally closed isolation valve is standard equipment to prevent pump debris from being transported back into the vacuum chamber when the pump is turned off:

- The opening of this valve must occur  $\geq 350$  ms after pump startup.
- Valve closing must occur  $\leq 250$  ms after pump shut off.  
The VPI Valve status is controlled by motor operation. The VPI Valve:
  - Opens when the pump is running and
  - Closes when it is stopped due to switch off or overload protection.

This TriScroll 800 Inverter Scroll pump includes the necessary communication cable, needed to operate the pump.

### Pump Inlet

Use NW40, or larger, clean vacuum hardware with as short a length as practical between the pump inlet and the vacuum chamber.

Use a bellows to provide both vibration isolation and strain relief between the pump and vacuum chamber.

### Pump Exhaust

A female 3/8 National Pipe Thread exhaust fitting is located underneath the scroll module. This fitting swivels 360°. Additionally, a NW25 adapter is provided with a 3/8 National Pipe Thread male thread.

### Gas Ballast

The pump incorporates an automatic gas ballast to prevent water and other condensates from accumulating within the pump. The standard configuration is a sintered filter installed in the 1/4" National Pipe Thread gas ballast port (item 8 on Figure 1 on page 30). This allows enough atmospheric air to enter the pump in order to purge condensates while not affecting pump ultimate pressure or pumping speed.

For applications where the ingress of atmospheric air is undesirable, dry nitrogen at a flow rate of  $\approx 5$  lpm can be bled into the gas ballast port. See item 8 on Figure 1 on page 30. Blocking of the gas ballast port is not recommended.

### Bearing Purge

A 1/4" National Pipe Thread bearing purge port (item 5 on Figure 1 on page 30) protects the main crankshaft bearings in applications where large amounts of water are being pumped. In the standard configuration, this port is sealed.

To enable the bearing purge, dry nitrogen at a flow rate of  $\approx 5$  lpm can be bled into the bearing purge port. This gas supply should be maintained at 2 psig or less and must be kept below 5 psig.

See "Purge Kit" on page 36.

## Operation

In order to reach ultimate vacuum, the pump must be left running for about one hour with the inlet sealed.

Unlike conventional oil-sealed pumps, Agilent's dry scroll pumps do not have fluid to cleanse them of accumulated dust and debris. Run the pump periodically at atmosphere for a minute or two to flush out the pump. Flush the pump regularly and adjust this schedule according to your specific conditions.

### Startup Procedure

1. Be sure that the vacuum system isolation valve is closed.
2. Turn on power to the pump.

#### NOTE



*Pump operation is interlock dependent. The provided mating connector must be plugged into P1 to start the pump.*

#### NOTE



*The integrated VPI solenoid must be connected to I/O P2 with the provided communications cable prior starting the pump.*

#### NOTE



*When the controller is switched on, an electronic self-test occurs, during which an orange LED illuminates for one second and the turns off for two seconds. During this time, the pump will not start.*

*This self-test time is not required if the pump is already powered, as when remotely or serially operated.*

3. Open the isolation valve.

### Shutdown Procedure

1. Close the vacuum system isolation valve. This prevents debris in pump from being transported into the vacuum system.
2. Turn off power to the pump.



# TriScroll 800 Inverter Pump Components View

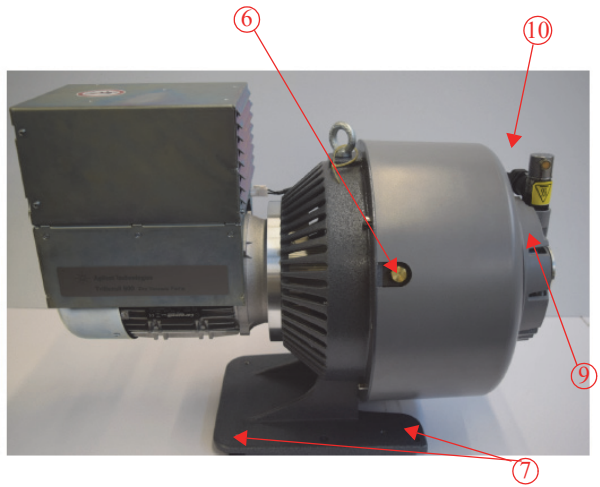
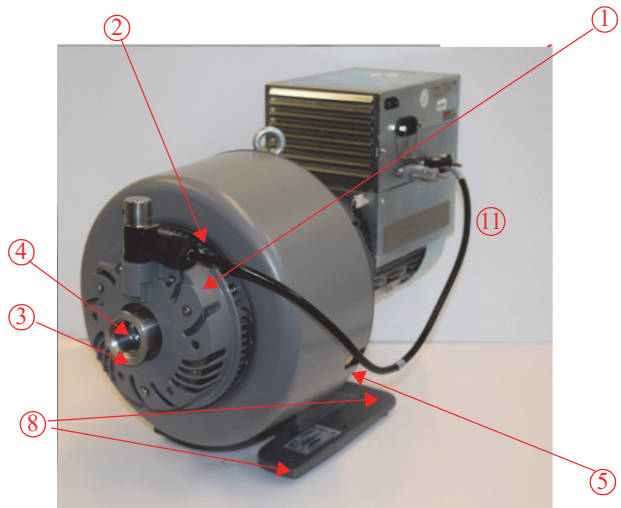

- ① VPI Plastic Cover Cowling
- ② Cowling Screws; M5 (3) (two shown)
- ③ Inlet (NW40)
- ④ Inlet Screen
- ⑤ Bearing Purge Port (1/4" NPT)
- ⑥ Gas Ballast Port (1/4" NPT)
- ⑦ Mounting Holes; 11 mm diameter thru (8)
- ⑧ Rubber Feet (4 underneath)
- ⑨ Integrated VPI Valve
- ⑩ VPI Solenoid
- ⑪ VPI Communication Cable
- ⑫ Power Connector (IEC 320)
- ⑬ On/Off Switch
- ⑭ Serial Port J1
- ⑮ Interlock Port P1 I/O-1
- ⑯ Interlock Port P2 I/O-2
- ⑰ TPS Connector
- NW25 Exhaust Adapter (Not Shown)

Figure 1 TriScroll 800 Inverter Vacuum Pump

# Technical Information

**Table 3 Specifications**

Model	TriScroll™ 800 Inverter Dry Scroll Vacuum Pump (PTS08001INV)
Interface dimensions	See Figure 2
Peak pumping speed	800 l/m, 48m <sup>3</sup> /hr (28.3 cfm) See Figure 3
Media	Clean air. No toxic, corrosive, explosive or particulate forming gases
Ultimate pressure (Torr)	10.0 x 10 <sup>-3</sup> Torr (13.3 x 10 <sup>-3</sup> mbar)
Maximum inlet pressure	1.0 atmosphere (0 psig)
Maximum continuous inlet pressure	100 Torr
Maximum outlet pressure	1.1 atmosphere (1.5 psig)
Inlet connection	NW40
Exhaust connection	Female 3/8" National Pipe Thread (NW25 adapter provided)
Gas ballast	Female 1/4" National Pipe Thread (40 Micron sintered filter provided)
Ambient operating temperature	5 °C to 40 °C (41 °F to 104 °F)
Storage temperature	-20 °C to 60 °C (-4 °F to 140 °F)
Motor rating	1.0 HP (0.75 kW)
Operating voltage	50-60 Hz:200-240 VAC Single-phase ±10%, 1200 VA
Maximum line current	200 VAC; 6 A 240 VAC; 5A
Motor Thermal Protection	Automatic
Operating speed	35-65 Hz Factory setting: 62 Hz, 1800 RPM
Cooling system	Air-cooled
Weight	Pump only: 32 kg (71 lbs) Shipping weight: 42 kg (92 lbs)
Noise level (per ISO 11201)	Variable with frequency, 58-71 dB(A)
Vibration level at inlet (per ISO 10816-1)	Variable with frequency
Main fuse	12.5 A, 250 V
Installation and storage	Installation category 2, indoor usage and storage
Pollution degree	2
Altitude	2000 m

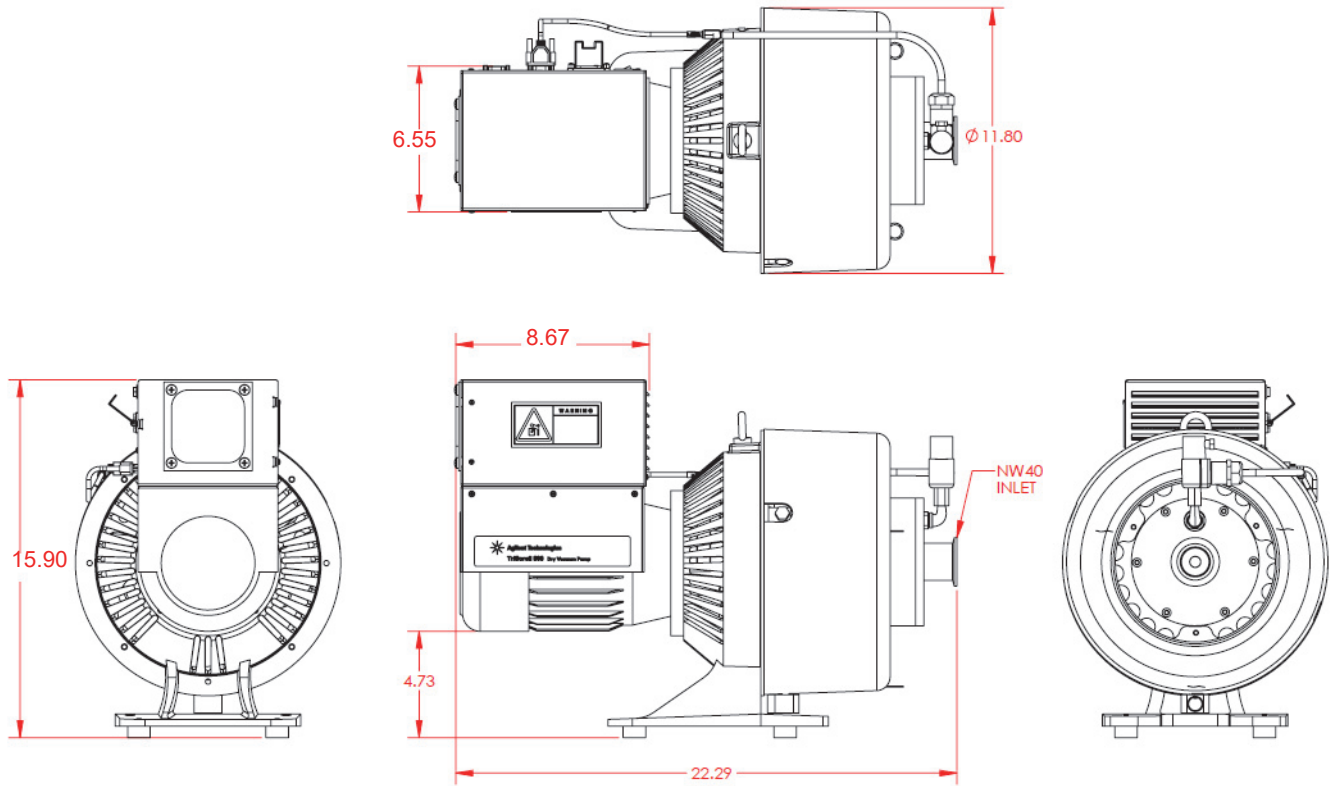

Figure 2 Interface Drawing with Dimensions

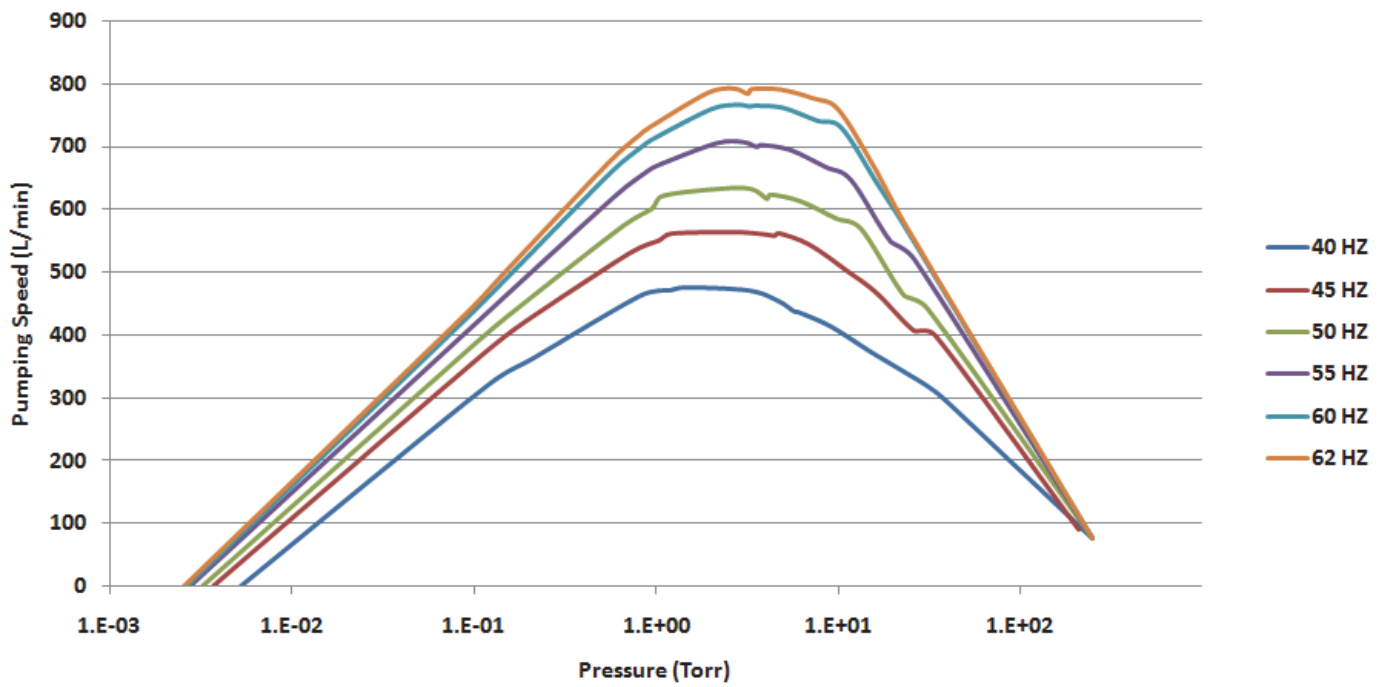

Figure 3 Pumping Speed Curves

# Pump Electrical Controller

The pump is powered by an inverter that converts single phase line power into 3-phase power that drives an induction motor at a user selectable frequency.

Several operational variables are modifiable through the J2 serial port when using Agilent T-Plus software. A number of additional system variables are also viewable.

Pump operation is interlocked through the P1 connector. Pins 4 and 5, and Pins 8 and 9, must be connected together to enable operation. A prewired connector is supplied with the pump and should be plugged into P1. The maximum power output of the inverter is 950 Watts. At pump inlet pressures above approximately 20 Torr, the pump will be power limited and the output frequency will be reduced. This mode is known as *autotuning*.

At pump start, the drive frequency is ramped up over several seconds. This provides for smooth starting and eliminates large in-rush currents.

## Technical Specifications

- Input voltage: 200 V-240 V / 50-60 Hz
- Max frequency: 65 Hz, factory set @ 62Hz
- Normal Operation maximum power: 850 W
- Protection level: IP 20

**Table 4 P1 I/O-1 Interlock**

PIN #	SIGNAL NAME	IN/OUT
1	Interlock contact 1	Out
2	0-10Vdc, with reference to pin 5 remote control	In

**Table 4 P1 I/O-1 Interlock**

PIN #	SIGNAL NAME	IN/OUT
3	No Connection	
4	Start/Stop (-): Connect to Pin 5	In
5	Groundout	Out
6	Interlock contact 2	Out
7	No Connection	
8	Start/Stop (+): Connect to Pin 9	In
9	+24V $\pm$ 5% 50mA, with reference to pin 5	Out

Remote speed setting allows you to control rotational speed using a 0-10 V analog input:

- $V_{in} > 9$  V: Driving frequency will be the full speed (factory set @62 Hz)
- $V_{in} < 1$  V: Driving frequency will be the minimum speed (35 Hz)

**NOTE**



*Pump operation is interlock dependent. The provided mating connector must be plugged into P1 to start the pump.*

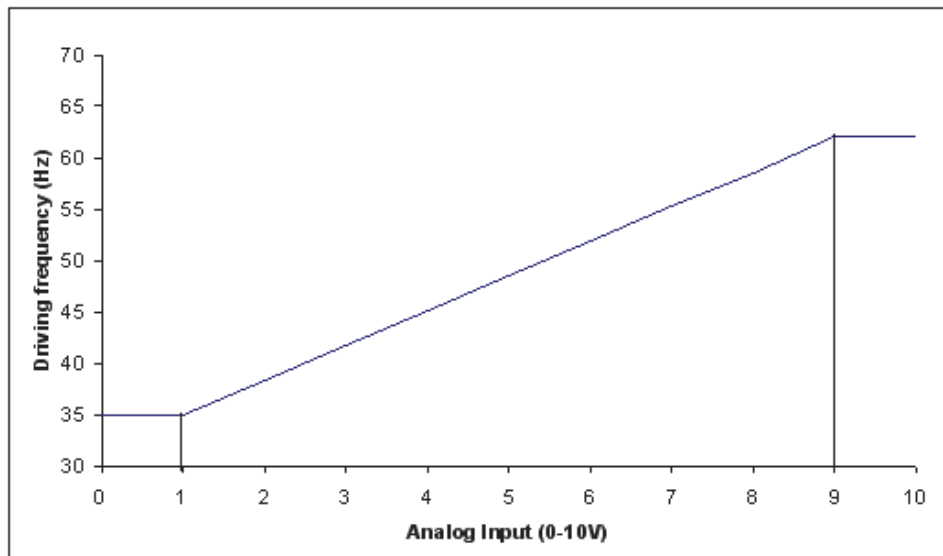

**Figure 4 Driving Frequency vs. Analog Input**

## Serial Interface Specification RS485 and RS232

**Table 5 J1 - Serial Port**

PIN #	SIGNAL NAME
1	+5V ±5%, 50mA, with reference to pin 5
2	RS232 TX
3	RS232 RX
4	No Connection
5	GND
6	RS485 A
7	No Connection
8	RS485 B
9	No Connection

Physical level: RS232 or RS485

Maximum baud: 9600, 8 data bit, no parity, 1 stop bit.

**Table 6 P2 I/O-2 Port on DB9 Male Connector**

PIN #	SIGNAL NAME
1	No Connection
2	No Connection
3	No Connection
4	No Connection
5	GND
6	No Connection
7	No Connection
8	No Connection
9	VPI output +24V ±5% 400mA, with reference to pin 5

**Table 7 T-Plus Software Variables**

WIN	TYPE	DESCRIPTION
000	Logical	Start/Stop (1=START; 0=STOP)
001	Logical	Low Speed [0=OFF / 1=ON]
008	Logical	Remote/Serial Configuration (1=REMOTE; 0=SERIAL)
102	Numerical	Set Point Value (Hz)
105	Numerical	Set Point Hysteresis (%) [0-100]
108	Numerical	Baud Rate (0-4) [600-1200-2400-4200-9600]
117	Numerical	Low Speed Adjust (Hz)
120	Numerical	Rotational Frequency Setting [Hz] (High speed adjust)
200	Numerical	Bus Current [mA]
201	Numerical	3 Phase Voltage [Vrms]
202	Numerical	Power [W]
203	Numerical	Driving Frequency [Hz]: (current driving frequency)
205	Numerical	Status:  <input type="checkbox"/> 0=stop <input type="checkbox"/> 2=ramp <input type="checkbox"/> 3=autotuning <input type="checkbox"/> 5=normal <input type="checkbox"/> 6=fail

**Table 7 T-Plus Software Variables (Continued)**

WIN	TYPE	DESCRIPTION
206	Numerical	Error Code: <input type="checkbox"/> Bit 7: motor block <input type="checkbox"/> Bit 6: short circuit <input type="checkbox"/> Bit 5: undervoltage <input type="checkbox"/> Bit 4: spare <input type="checkbox"/> Bit 3: power fail <input type="checkbox"/> Bit 2: controller overt <input type="checkbox"/> Bit 1: pump overt <input type="checkbox"/> Bit 0: spare
211	Numerical	Controller Temperature [°C]
216	Numerical	Environment Temperature [°C]
300	Numerical	Cycle Time [min]
301	Numerical	Cycle Number
302	Numerical	Pump Life [h]
319	Alphanumeric	Controller Model
323	Alphanumeric	Controller Serial Number
325	Alphanumeric	Electrical Modification Level
500	Logical	Monitor Mode (write only)
503	Numerical	RS485 Serial Address Setting [0-31]
504	Logical	Serial Type Select (0=RS323; 1=RS485)

**Table 8 Status LEDs**

LED STATUS	CONTROLLER STATUS
Off	Stop
Green flashing	Ramp or Autotuning
Green	Normal Operation
Red	Fail
Orange + Off	Reset + selftest

**NOTE**



When the controller is switched on, an electronic self-test occurs, during which an orange LED illuminates for one second and the turns off for two seconds. During this time, the pump will not start.

This self-test time is not required if the pump is already powered, as when remotely or serially operated.

**Using T-Plus Software To Change The Target Frequency**

1. Install T-Plus software on your PC by running setup.exe.
2. Using a 9-pin serial cable, connect your PC to the J2 serial port on the inverter (Figure 5).
3. Start the pump using the On/Off switch. The provided Interlock Connector must be installed in P1.
4. Start the T-Plus software and Figure 5 appears.

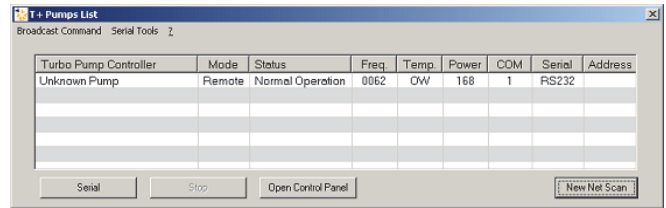

**Figure 5 T+ Pumps List**

5. Click **Open Control Panel** and Figure 6 appears.
6. Open the *Speed Settings* directory, and click **Target Frequency**.

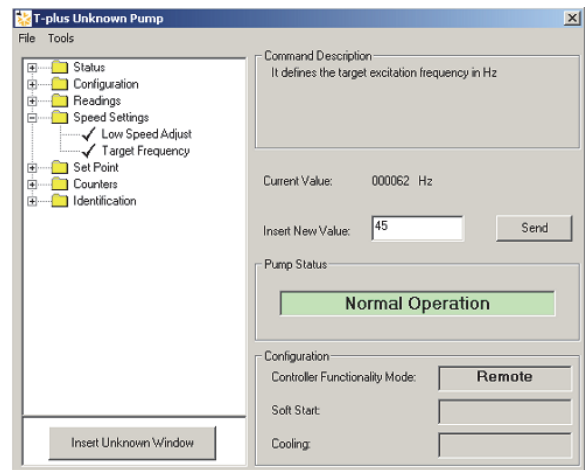

**Figure 6 T-Unknown Pump**

7. Enter the desired operating frequency into *Insert New Value*. This must be an integer between 35 and 65.
8. Click **Send**. The pump immediately tries to change to the new target frequency. If the pump requires more than 750 Watts to attain the target frequency, the pump is power limited and will run at a lower frequency (auto-tuning).

mode). This condition continues until the power required drops below 750 Watts.

The target frequency is stored in the inverter even when power to the pump is removed.

## Purge Kit

A purge kit (Agilent part number PTSPURGEKIT) is available to properly purge either the bearing purge or the gas ballast. This kit contains a flowmeter and all necessary valving and tubing.

## Exhaust Silencer Kit

In certain applications it is desired to lower the noise level emitted by the pump. For these cases, Agilent offers Exhaust Silencer Kits (P/N EXSLRTRISCROLL, Manual P/N: 699904380), which breaks up noise pulsation in the discharge line.

The Exhaust Silencer Kits contain two basic components, as well as installation hardware. A cylindrical resonator chamber has been selected to attenuate the frequencies associated with the exhaust gas pulsation noise. The resonator is then plumbed to an exhaust muffler/filter. This muffler provides the majority of the actual noise reduction. It also contains an integral 5-micron paper filter element to capture any tip seal debris. This paper filter is replaceable; the recommended service interval is whenever the pump tip seal or module maintenance is performed.

Replacement polyester filter element rated 99% efficient at the 5-micron particle size, P/N: REPLSLRFILTER,

## Vibration Isolation Kit

A set of vibration isolation mounts (P/N PTSVIBISOKIT, Manual P/N: 699904385) are available for Agilent scroll pumps. These are used in place of the standard feet installed on the pump for applications that require minimal vibration transmission from the pump to the installation. They can be used alone, or with inlet flexible bellows to provide pump isolation.

The vibration isolation mounts in the Vibration Isolation Kit have been designed to ensure the lowest vibration level transmitted at the base of the pump.

Vibration level in every direction (axis), transmitted to the surface the pump sits on, is reduced by a significant amount. Typical vibration reduction levels are 75% for the TriScroll 800 pump.

The TriScroll Vibration Isolation Kit consists of (4) vibration isolation mounts. They have a M6 metric threaded screw to attach to the TriScroll frame; the screw is provided.

These mounts increase the height of the TriScroll pumps by 0.75" compared to the standard mounting feet.

## HEPA Inlet filter

Agilent now offers inlet filters for the scroll pumps, which protect the pump from ingested particles, and keep particles from migrating out of the pump. These HEPA filters provide a rated 99.97% efficiency in trapping particles > 0.3 microns.

NW 40 Inlet Trap with HEPA filter insert: P/N#: SCRINTRPNW40.

Replacement HEPA filter element P/N#: RPLHEPAFILTER1

# Troubleshooting

Table 9 contains a list of possible problems, their probable causes, and corrective actions.

**Table 9 Troubleshooting Chart**

<b>Problem</b>	<b>Probable Cause</b>	<b>Corrective Action</b>
Pump won't start	P1 interlock missing	Plug in connector (provided).
	TPS cable unplugged	Plug in TPS cable
	Wrong input voltage	Plug inverter into 200-240 VAC 50/60 Hz.
	Circuit breaker open	Close breaker. Identify cause of overload.
	Motor thermal protector open	Allow motor to cool. Identify cause of overload.
	Main fuse open	Inspect and replace fuse (Type H, 10 A, 250 V (Littlefuse 0216010.HxP or equivalent)).
	Wiring loose or cut	Repair or replace.
	Excessive voltage drop	Check size and length of power supply cable.
	Defective motor	Inspect. Contact Agilent.
Poor ultimate pressure	System leak	Locate and repair leak.
	Water in pump	Flush pump with air or dry nitrogen.
	Gas ballast plugged	Replace breather vent. Contact Agilent.
	Solvent in pump	Flush pump with air or dry nitrogen. Install trap or filter.
	Seals worn out	Replace tip seals. (Table 10 and Table 11 on page 38 list maintenance kits and service options.)
	Poor conductance to pump	Replumb with shorter and/or larger diameter tubing.
Pump makes hammering noise	Pump overheated	Check ambient temperature. Check ventilation to pump.
	Debris in pump	Check inlet screen. Flush pump. Disassemble pump and inspect. (Table 10 and Table 11 on page 38 list maintenance kits and service options.)



# Maintenance

## General Information

Agilent TriScroll 800 Inverter pump is designed to provide years of trouble-free service if maintenance procedures and intervals are observed. Bearing grease replenishment and tip seal replacement is recommended when pump base pressure has risen to an unacceptably high level for your application. Bearings, rotary seals and O-rings should also be replaced if the pump exhibits humming or grinding noises from the bearings. Main bearing life may be shortened if your application requires the pumping of high quantities of water vapor. Use of the bearing purge kit (PTSPURGEKIT) mentioned earlier will keep this water from impacting bearing life.

Maintenance should be performed in accordance with procedures, tooling and materials specified in the manuals listed below.

## Related TriScroll Manuals

Other manuals related to tip seal replacement, pump module replacement, and major maintenance of the TriScroll 800 Inverter pump are listed in Table 10.

**Table 10 Other Related Manuals**

Title	Applicable TriScroll Model	Part Number
Tip Seal Replacement Manual	All TriScroll 800 Series models	699904310

## Maintenance and Tooling Kits

Material and tooling required to perform maintenance on TriScroll pumps is provided in kit form. A description of each kit and ordering information is provided in Table 11.

**Table 11 Maintenance and Tooling Kits**

Description	Contents	Applicable TriScroll Model	Part Number
Tip Seal Tool Kit	All tools required to change the tip seals on the TriScroll 800 Series pumps.	All TriScroll 800 Series models	PTSTSTKIT
Replacement Tip Seal Set	Replacement tip seals and static O-rings for TriScroll 800 Series pumps.	All TriScroll 800 Series models	PTSS0800TS

### NOTE



*After tip seal replacement, the TriScroll 800 Inverter pump may require up to 100 hours run time to achieve full rotational speed.*

## Factory Service Options

Table 12 lists the lists the service options that Agilent offers for the TriScroll 800 Inverter pump.

**Table 12 Factory Service Options**

Factory Service Options	Part Number
Advance Exchange TriScroll 800 Inverter Pump Module Only	EXPTS0800SC

## Accessories

The accessories listed in Table 13 are available for use with the TriScroll 800 Inverter pump. Contact your local Agilent office to place an order. A list of offices is included on the rear cover of this manual.

**Table 13 Accessories**

Purge Kit	PTSPURGEKIT
Exhaust Extension	S4807001
Exhaust Filter Kit	PTS800EXFIL
Isolation Valve Kit	VPI40INV24DC
Exhaust Silencer Kit	EXSLRTRISCROLL
Vibration Isolation Kit	PTSVIBISOKIT
HEPA Inlet Filters	SCRINTRPNW40

## Contacting Agilent

In the United States, you can contact Agilent Customer Service at 1-800-882-7426. See the back cover of this manual for a listing of our sales and service offices.

*This page intentionally left blank.*





Dear Customer:

Please follow these instructions whenever one of our products needs to be returned.

1) Complete the attached Request for Return form and send it to Agilent Technologies (see below), taking particular care to identify all products that have pumped or been exposed to any toxic or hazardous materials.

2) After evaluating the information, Agilent Technologies will provide you with a Return Authorization (RA) number via email or fax, as requested.

**Note:** Depending on the type of return, a Purchase Order may be required at the time the Request for Return is submitted. We will quote any necessary services (evaluation, repair, special cleaning, eg).

**3) Important steps for the shipment of returning product:**

- Remove all accessories from the core product (e.g. inlet screens, vent valves).
- Prior to shipment, drain any oils or other liquids, purge or flush all gasses, and wipe off any excess residue.
- If ordering an Advance Exchange product, **please use the packaging from the Advance Exchange to return the defective product.**
- Seal the product in a plastic bag, and package product carefully to avoid damage in transit. You are responsible for loss or damage in transit.
- Agilent Technologies is not responsible for returning customer provided packaging or containers.
- **Clearly label package with RA number.** Using the shipping label provided will ensure the proper address and RA number are on the package. Packages shipped to Agilent without a RA clearly written on the outside cannot be accepted and will be returned.

4) Return only products for which the RA was issued.

5) **Product being returned under a RA must be received within 15 business days.**

6) **Ship to the location specified on the printable label, which will be sent, along with the RA number, as soon as we have received all of the required information.** Customer is responsible for freight charges on returning product.

7) Return shipments must comply with all applicable **Shipping Regulations** (IATA, DOT, etc.) and carrier requirements.

**Vacuum Products Division  
Request for Return Form  
(Health and Safety Certification)**

Please read important policy information on Page 3 that applies to all returns.

**1) CUSTOMER INFORMATION**

<b>Company Name:</b>		<b>Contact Name:</b>	
<b>Tel:</b>	<b>Email:</b>	<b>Fax:</b>	
<b>Customer Ship To:</b>		<b>Customer Bill To:</b>	
Europe only: <b>VAT reg. Number:</b>		USA/Canada only: <input type="checkbox"/> <b>Taxable</b> <input type="checkbox"/> <b>Non-taxable</b>	

**2) PRODUCT IDENTIFICATION**

Product Description	Agilent P/N	Agilent S/N	Original Purchasing Reference

**3) TYPE OF RETURN** (Choose one from each row and supply Purchase Order if requesting a billable service)

- 3A.  Non-Billable     Billable    **New PO #** (hard copy must be submitted with this form):
- 3B.  Exchange     Repair     Upgrade     Consignment/Demo     Calibration     Evaluation     Return for Credit

**4) HEALTH and SAFETY CERTIFICATION**

**AGILENT TECHNOLOGIES CANNOT ACCEPT ANY PRODUCTS CONTAMINATED WITH BIOLOGICAL OR EXPLOSIVE HAZARDS, RADIOACTIVE MATERIAL, OR MERCURY AT ITS FACILITY.**  
**Call Agilent Technologies to discuss alternatives if this requirement presents a problem.**

**The equipment listed above (check one):**

**HAS NOT** pumped or been exposed to any toxic or hazardous materials. OR

**HAS** pumped or been exposed to the following toxic or hazardous materials. If this box is checked, the following information must also be filled out. Check boxes for all materials to which product(s) pumped or was exposed:

Toxic     Corrosive     Reactive     Flammable     Explosive     Biological     Radioactive

**List all toxic/hazardous materials. Include product name, chemical name, and chemical symbol or formula:**

---

**NOTE:** If a product is received at Agilent which is contaminated with a toxic or hazardous material that was not disclosed, **the customer will be held responsible** for all costs incurred to ensure the safe handling of the product, and **is liable** for any harm or injury to Agilent employees as well as to any third party occurring as a result of exposure to toxic or hazardous materials present in the product.

**Print Name:** \_\_\_\_\_ **Authorized Signature:** ..... **Date:** \_\_\_\_\_

**5) FAILURE INFORMATION:**

Failure Mode (REQUIRED FIELD. See next page for suggestions of failure terms):
Detailed Description of Malfunction: (Please provide the error message)
Application (system and model):

**I understand and agree to the terms of Section 6, Page 3/3.**

**Print Name:** \_\_\_\_\_ **Authorized Signature:** ..... **Date:** \_\_\_\_\_

**Vacuum Products Division  
Request for Return Form  
(Health and Safety Certification)**

Please use these Failure Mode to describe the concern about the product on Page 2.

**TURBO PUMPS and TURBO CONTROLLERS**

APPARENT DEFECT/MALFUNCTION	POSITION	PARAMETERS
<ul style="list-style-type: none"> <li>- Does not start</li> <li>- Does not spin freely</li> <li>- Does not reach full speed</li> <li>- Mechanical Contact</li> <li>- Cooling defective</li> </ul>	<ul style="list-style-type: none"> <li>- Noise</li> <li>- Vibrations</li> <li>-Leak</li> <li>-Overtemperature</li> <li>-Clogging</li> </ul>	<ul style="list-style-type: none"> <li>- Vertical</li> <li>-Horizontal</li> <li>-Upside-down</li> <li>-Other:</li> <li>.....</li> </ul>
		<ul style="list-style-type: none"> <li>Power:                      Rotational Speed:</li> <li>Current:                    Inlet Pressure:</li> <li>Temp 1:                    Foreline Pressure:</li> <li>Temp 2:                    Purge flow:</li> <li>OPERATING TIME:</li> </ul>

**ION PUMPS/CONTROLLERS**

<ul style="list-style-type: none"> <li>- Bad feedthrough</li> <li>- Vacuum leak</li> <li>- Error code on display</li> </ul>	<ul style="list-style-type: none"> <li>- Poor vacuum</li> <li>- High voltage problem</li> <li>- Other</li> </ul>
---	--

**VALVES/COMPONENTS**

<ul style="list-style-type: none"> <li>- Main seal leak</li> <li>- Solenoid failure</li> <li>- Damaged sealing area</li> </ul>	<ul style="list-style-type: none"> <li>- Bellows leak</li> <li>- Damaged flange</li> <li>-Other</li> </ul>
--	--

**LEAK DETECTORS**

<ul style="list-style-type: none"> <li>- Cannot calibrate</li> <li>- Vacuum system unstable</li> <li>- Failed to start</li> </ul>	<ul style="list-style-type: none"> <li>-No zero/high background</li> <li>- Cannot reach test mode</li> <li>- Other</li> </ul>
---	---

**INSTRUMENTS**

<ul style="list-style-type: none"> <li>- Gauge tube not working</li> <li>- Communication failure</li> <li>- Error code on display</li> </ul>	<ul style="list-style-type: none"> <li>- Display problem</li> <li>- Degas not working</li> <li>- Other</li> </ul>
--	---

**SCROLL AND ROTARY VANE PUMPS**

<ul style="list-style-type: none"> <li>- Pump doesn't start</li> <li>- Doesn't reach vacuum</li> <li>- Pump seized</li> </ul>	<ul style="list-style-type: none"> <li>- Noisy pump (describe)</li> <li>- Over temperature</li> <li>- Other</li> </ul>
---	--

**DIFFUSION PUMPS**

<ul style="list-style-type: none"> <li>- Heater failure</li> <li>- Doesn't reach vacuum</li> <li>- Vacuum leak</li> </ul>	<ul style="list-style-type: none"> <li>- Electrical problem</li> <li>- Cooling coil damage</li> <li>- Other</li> </ul>
---	--

Section 6) **ADDITIONAL TERMS**

**Please read the terms and conditions below as they apply to all returns and are in addition to the Agilent Technologies Vacuum Product Division – Products and Services Terms of Sale.**

- Customer is responsible for the freight charges for the returning product. Return shipments must comply with all applicable **Shipping Regulations** (IATA, DOT, etc.) and carrier requirements.
- Customers receiving an Advance Exchange product agree to return the defective, rebuildable part to Agilent Technologies **within 15 business days**. Failure to do so, or returning a non-rebuildable part (crashed), will result in an invoice for the non-returned/non-rebuildable part.
- Returns for credit toward the purchase of new or refurbished Products are subject to prior Agilent approval and may incur a restocking fee. Please reference the original purchase order number.
- Units returned for evaluation will be evaluated, and a quote for repair will be issued. If you choose to have the unit repaired, the cost of the evaluation will be deducted from the final repair pricing. A Purchase Order for the final repair price should be issued within 3 weeks of quotation date. Units without a Purchase Order for repair will be returned to the customer, and the evaluation fee will be invoiced.
- A Special Cleaning fee will apply to all exposed products per Section 4 of this document.
- If requesting a calibration service, units must be functionally capable of being calibrated.