

Varian TriScroll 600 Dry Scroll Pump

Chemtech Scientific provides access to this content as a courtesy.
We do not own the content contained in this document.
All rights and credit go directly to its rightful owners.
www.chemtechsci.com
Call us at: 484-424-9415



TriScroll™ 600 Series Dry Scroll Vacuum Pump

Manual No. 699904290
Revision K
February 2005

vacuum technologies



*INSTALLATION AND
OPERATION MANUAL*

*INSTALLATIONS- UND
BETRIEBSHANDBUCH*

*MANUEL D'INSTALLATION
ET D'OPÉRATION*

*MANUAL DE INSTALACIÓN Y
FUNCIONAMIENTO*

*MANUALE
D'INSTALLAZIONE E D'USO*

TriScroll™ 600 Series Dry Scroll Vacuum Pump



TriScroll is a trademark of Vacuum Technologies.

Table of Contents

Declaration of Conformity	
Warranty	viii
Warranty Replacement and Adjustment.....	viii
Instructions for Use	1
General Information	1
Storage	1
Unpacking and Inspection.....	1
Installation Requirements	2
Safety	2
Operation.....	4
Startup Procedure	4
Shutdown Procedure	4
Maintenance	4
Anleitungen zur Benutzung	5
Allgemeine Informationen	5
Lagerung	5
Auspacken und Inspektion	5
Installationsanforderungen	6
Sicherheit	6
Betrieb	8
Startverfahren	8
Abschaltverfahren.....	8
Wartung	8
Instructions d'utilisation	9
Informations générales	9
Stockage.....	9
Déballage et Inspection.....	10
Exigences d'installation	10
Sécurité	10
Opération.....	12
Procédure de démarrage.....	12
Procédure d'arrêt.....	12
Entretien.....	12
Instrucciones de uso	13
Información general	13
Almacenaje	13
Desembalaje e inspección.....	13
Requisitos de instalación	14
Seguridad	14
Funcionamiento	16
Procedimiento de arranque	16
Procedimiento de parada.....	16
Mantenimiento	16
Istruzioni per l'uso	17
Informazioni generali	17
Conservazione	17
Disimballaggio ed ispezione	17
Requisiti per l'installazione	18
Sicurezza	18
Funzionamento	20
Procedura per l'avviamento.....	20
Procedura per lo spegnimento.....	20
Manutenzione	20
使用仕様	21
概況概要	21
保存	21
開梱と点検	21
取付要求	22
安全	22
操作	24
スタートアップ手順	24
シャットダウン手順	24
保守	24
使用说明	25
一般信息	25
存放	25
开箱和检查	25
安装要求	26
安全	26
操作	28
启动过程	28
关机过程	28
维护	28
사용설명	29
일반정보	29
보관	29
포장 열기 및 검사	29
설치요구	30
안전장치	30
조작	32
시동 과정	32
중단 과정	32
유지	32

TriScroll 600 Series Vacuum Pump

Technical Information	33
Electrical Connections.....	36
Single Phase Motor Connection.....	36
Three Phase Motor Connection	37
Mechanical Connections.....	38
Pump Location	38
Rotation of the Pump Inlet with Respect to the Motor Frame	38
Pump Inlet.....	38
Pump Exhaust.....	38
Optional Isolation Valve.....	38
Gas Ballast	39
Bearing Purge.....	39
Purge Kit	39
Troubleshooting	40
Maintenance	41
General Information	41
Related TriScroll Manuals.....	41
Maintenance and Tooling Kits	41
Factory Service Options.....	42
Accessories.....	42
Contacting Vacuum Technologies	42

Request for Return Health and Safety Certification

List of Figures

Figure	Caption	Page
1	Interface Drawing with Dimensions	34
2	Pumping Speed Curves	34
3	TriScroll 600 Series Vacuum Pump (Single Phase Pump Shown)	35
4	Single Phase Motor Electrical Connections .	36
5	Three Phase Motor Electrical Connections .	37
6	Isolation Valve Location.	38

List of Tables

Table	Title	Page
1	Pump Models and Power Cords.....	3
2	Circuit Breaker Requirements.....	3
3	Pumpenmodelle und Versorgungskabel	7
4	Anforderungen an Stromunterbrecher	7
5	Modèles de pompes et câbles	11
6	Exigences des coupe-circuits	11
7	Modelos de bomba y cables de corriente.....	15
8	Requisitos del disyuntor.....	15
9	Modelli di pompe e cavi di alimentazione... ..	19
10	Requisiti dell'interruttore automatico	19
11	ポンプ型式と電源コード	23
12	遮断器の要求	23
13	泵型号和电源电缆	27
14	断路器要求	27
15	펌프모델 및 코드	31
16	브레이커 요구	31
17	Specifications	33
18	Full Load Motor Currents, Amperes.....	36
19	VPI Valve Installation Data	39
20	Troubleshooting Chart	40
21	Other Related Manuals	41
22	Maintenance and Tooling Kits	41
23	Factory Service Options	42
24	Accessories.....	42

This page intentionally left blank.

Declaration of Conformity
Konformitätserklärung
Déclaration de Conformité
Declaración de Conformidad
Verklaring de Overeenstemming
Dichiarazione di Conformità

We
Wir
Nous
Nosotros
Wij
Noi

declare under our sole responsibility that the product,
erklären, in alleiniger Verantwortung, daß dieses Produkt,
déclarons sous notre seule responsabilité que le produit,
declaramos, bajo nuestra sola responsabilidad, que el producto,
verklaren onder onze verantwoordelijkheid, dat het product,
dichiariamo sotto nostra unica responsabilità, che il prodotto,

to which this declaration relates is in conformity with the following standard(s) or other normative documents.
auf das sich diese Erklärung bezieht, mit der/den folgenden Norm(en) oder Richtlinie(n) übereinstimmt.
auquel se réfère cette déclaration est conforme à la (aux) norme(s) ou au(x) document(s) normatif(s).
al que se refiere esta declaración es conforme a la(s) norma(s) u otro(s) documento(s) normativo(s).
waamaar deze verklaring verwijst, aan de volgende norm(en) of richtlijn(en) beantwoordt.
a cui si riferisce questa dichiarazione è conforme alla/e seguente/i norma/o documento/i normativo/i.

EN 1050:1996	Compressors and Vacuum pumps Safety Reqmts; Part 2 Vacuum Pumps
EN 60204-1	Safety of machinery - principles for risk assessment
73/023/EEC, Low Voltage Directive	Electrical equipment of industrial machines; general requirements
EN 60034 part 1	Rotating electrical machines - Part 1: Rating and performance
89/336/EEC, Electromagnetic Compatibility Directive	
EN 61000-4-2	Testing and Measurement Techniques - Electrostatic Discharge Immunity Test



Warranty

Products manufactured by Seller are warranted against defects in materials and workmanship for twelve (12) months from date of shipment thereof to Customer, and Seller's liability under valid warranty claims is limited, at the option of Seller, to repair, to replace, or refund of an equitable portion of the purchase price of the Product. Items expendable in normal use are not covered by this warranty. All warranty replacement or repair of parts shall be limited to equipment malfunctions which, in the sole opinion of Seller, are due or traceable to defects in original materials or workmanship. All obligations of Seller under this warranty shall cease in the event of abuse, accident, alteration, misuse, or neglect of the equipment. In-warranty repaired or replaced parts are warranted only for the remaining unexpired portion of the original warranty period applicable to the repaired or replaced parts. After expiration of the applicable warranty period, Customer shall be charged at the then current prices for parts, labor, and transportation.

Reasonable care must be used to avoid hazards. Seller expressly disclaims responsibility for loss or damage caused by use of its Products other than in accordance with proper operating procedures.

Except as stated herein, Seller makes no warranty, express or implied (either in fact or by operation of law), statutory or otherwise; and, except as stated herein, Seller shall have no liability under any warranty, express or implied (either in fact or by operation of law), statutory or otherwise. Statements made by any person, including representatives of Seller, which are inconsistent or in conflict with the terms of this warranty shall not be binding upon Seller unless reduced to writing and approved by an officer of Seller.

Warranty Replacement and Adjustment

All claims under warranty must be made promptly after occurrence of circumstances giving rise thereto, and must be received within the applicable warranty period by Seller or its authorized representative. Such claims should include the Product serial number, the date of shipment, and a full description of the circumstances giving rise to the claim. Before any Products are returned for repair and/or adjustment, written authorization from Seller or its authorized representative for the return and instructions as to how and where these Products should be returned must be obtained. Any Product returned to Seller for examination shall be prepaid via the means of transportation indicated as acceptable by Seller. Seller reserves the right to reject any warranty claim not promptly reported and any warranty claim on any item that has been altered or has been returned by non-acceptable means of transportation. When any Product is returned for examination and inspection, or for any other reason, Customer shall be responsible for all damage resulting from improper packing or handling, and for loss in transit, notwithstanding any defect or non-conformity in the Product. In all cases, Seller has the sole responsibility for determining the cause and nature of failure, and Seller's determination with regard thereto shall be final.

If it is found that Seller's Product has been returned without cause and is still serviceable, Customer will be notified and the Product returned at its expense; in addition, a charge for testing and examination may be made on Products so returned.

3/1/00

Instructions for Use

General Information

This equipment is designed for use by professionals. The user should read this instruction manual and any other additional information supplied by Vacuum Technologies before operating the equipment. Vacuum Technologies will not be held responsible for any events that occur due to non-compliance with these instructions, improper use by untrained persons, non-authorized interference with the equipment, or any action contrary to that provided for by specific national standards.

The TriScroll™ 600 is a dry scroll vacuum pump. This pump is suitable for pumping air or inert gases. The pump is not intended to pump toxic, corrosive, explosive, or particulate-forming gases.

The following paragraphs contain all the information necessary to guarantee the safety of the operator when using the equipment. Detailed information is supplied in “Technical Information” on page 33.

This manual uses the following standard safety protocol:

WARNING



The warning messages are for attracting the attention of the operator to a particular procedure or practice which, if not followed correctly, could lead to serious injury.

CAUTION



The caution messages are displayed before procedures, which if not followed, could cause damage to the equipment.

NOTE



The notes contain important information taken from the text.

Storage

When transporting and storing the pump, the following environmental requirements should not be exceeded:

Temperature: –20 °C to 60 °C (–4 °F to 140 °F)
Relative humidity: 0 to 95% (non-condensing)

Unpacking and Inspection

The shipping container is a double carton.

1. After opening the outer box, remove the foam packing.
2. Slit open the inner box.
3. Lift the pump with the plywood base out of the inner box.
4. Remove the four bolts securing the pump frame to the plywood base.
5. Locate the NW25 exhaust fitting and set it aside.
6. Inspect the pump for damage.

If there is shipping damage, contact the freight carrier and your local Vacuum Technologies sales office immediately.

7. Save the carton and packing materials.

Total weight of the package, including the pump, is approximately 40 kg (87 lbs).

WARNING



When unpacking the pump, be sure not to drop it, and avoid any kind of sudden impact or shock vibration to it.

WARNING



The TriScroll 600 weighs 32 kg (70 lbs). To avoid injury, use proper lifting techniques when moving the pump.

NOTE



Normal exposure to the environment cannot damage the pump. Nevertheless, it is advisable to keep the pump inlet closed until the pump is installed in the system.

Installation Requirements

Safety

Do not remove or modify any safety or insulating equipment from the pump. To do so may create a serious safety hazard and may void the warranty.

WARNING



- ❑ *This pump is designed to pump air and inert gases only; it is not designed to pump explosive, flammable, toxic, or corrosive gases. They can cause bodily injury, explosion, or fire.*
- ❑ *Install in an area that is not exposed to rain, steam, or excessive humidity. They can cause electric shock, short circuits, and severe bodily injury.*
- ❑ *Before inspecting or servicing the pump, be sure the electrical supply is disconnected.*
- ❑ *Consult a qualified electrician whenever wiring the pump.*

CAUTION



Although the pump can pump trace particulates normally found in the atmosphere, it is not designed for process solids, chemicals, powders, solvents, condensates, or other particulates. They can damage the equipment, degrade its performance, or shorten its useful life.

Single and three phase pumps operate in a clockwise direction when viewed from the motor end. (Note the arrow on the pump frame.) Improper rotation can cause permanent damage to the pump.

During operation, the following environmental conditions should not be exceeded:

Temperature: +5 °C to +40 °C (41 °F to 104 °F)

Relative humidity: 0 to 95% (non-condensing)

CAUTION



Do not block the fan ducts because the pump can become overheated. A pump surface temperature in excess of 55 °C (131 °F) is potentially damaging. If such conditions are observed, turn pump off and allow to cool. Disassemble, inspect for damage, and repair if necessary.

CAUTION



As supplied from the factory, the pump is configured as shown in the following table. Verify that the configuration matches the supply voltage.

If voltage changeover is required, configure the voltage as described in "Electrical Connections" on page 36 and page 37.

TriScroll 600 Series Vacuum Pump

Table 1 lists the available TS-600 pump models and indicates the power cord to be used with each particular pump.

Three phase pumps are shipped without a power cord. A three phase power cable kit, Vacuum Technologies part number S4789001, is available. This kit does not include a plug.

Table 1 Pump Models and Power Cords

Pump Model	Motor Voltage	Plug Type	Fusing	Conductor Size	Cord Marking	Cord Length
PTS06001UNIV	100-115 VAC	NEMA 5-15P	-	14 Gage	UL/CSA	2.5 m
PTS06001UNIVEU	200-230 VAC	CEE 7/7	-	3x1.50 mm ²	<HAR>	2.5 m
PTS06001UNIVUK	200-230 VAC	BS 1363	BS 1362 13 Amp	3x1.50 mm ²	<HAR>	2.5 m
PTS06003UNIV	200-230 VAC	-	-	-	-	-
PTS06101UNIV	100-115 VAC	NEMA 5-15P	-	14 Gage	UL/CSA	2.5m
PTS06001UVPI	100-115 VAC	NEMA 5-15P	-	14 Gage	UL/CSA	2.5m

Circuit Breakers

WARNING



Protect against short circuits by installing a circuit breaker of the proper capacity.

Table 2 lists the circuit breaker capacity required for pump motors of various voltages, single and three-phase.

Table 2 Circuit Breaker Requirements

Single Phase Motor	100-115 VAC 50/60 Hz	200-230 VAC 50/60 Hz
Breaker capacity	20 Amperes	10 Amperes
Three Phase Motor	200-230 VAC	380-415-460 VAC
Breaker capacity	10 Amperes	5 Amperes

Operation

In order to reach ultimate vacuum, the pump must be left running for about one hour with the inlet sealed.

Unlike conventional oil-sealed pumps, Vacuum Technologies's dry scroll pumps do not have fluid to cleanse them of accumulated dust and debris. Run the pump periodically at atmosphere for a minute or two to flush out the pump. Flush the pump regularly and adjust this schedule according to your specific conditions.

Startup Procedure

1. Be sure that the vacuum system isolation valve is closed.
2. Turn on power to the pump.
3. Open the isolation valve.

Shutdown Procedure

1. Close the vacuum system isolation valve. This prevents debris in pump from being transported into the vacuum system.
2. Turn off power to the pump.

Maintenance

Personnel responsible for pump operation and maintenance must be well-trained and aware of the accident prevention rules.

WARNING



- ❑ *Death may result from contact with high voltages. Always take extreme care and observe the accident prevention regulations in force.*
- ❑ *When the machine is powered up, be careful of moving parts and high voltages.*
- ❑ *If you have to perform maintenance on the pump after a considerable time in operation, allow the pump to cool as the temperature of the outer surface may be in excess of 55 °C (131 °F).*
- ❑ *Always disconnect your power supply to the pump before beginning maintenance work.*

NOTE



Before returning the pump to the factory for repair, the "Health and Safety" sheet attached to this instruction manual must be completed and sent to the local sales office. A copy of the sheet must be inserted in the pump package before shipping.

If a pump is to be discarded, it must be disposed of in accordance with specific national and local standards.

Anleitungen zur Benutzung

Allgemeine Informationen

Dieses Gerät ist zur Benutzung durch Fachkräfte bestimmt. Der Benutzer muss vor der Bedienung des Gerätes das Anleitungshandbuch und alle zusätzlichen von Vacuum Technologies zur Verfügung gestellten Informationen gelesen haben. Vacuum Technologies kann nicht für Vorfälle verantwortlich gemacht werden, die aus der Nichtbeachtung dieser Anleitungen, aus der inkorrekten Verwendung des Gerätes durch ungeschulte Personen und aus dem unbefugten Umgang mit dem Gerät oder anderen den zutreffenden gültigen Normen zuwiderlaufenden Handlungen resultieren.

Die TriScroll™ 600 ist eine trockene Scroll-Vakuumpumpe. Diese Pumpe eignet sich zum Pumpen von Luft oder inerten Gasen. Die Pumpe ist nicht zum Pumpen von toxischen, korrosiven, explosiven oder partikelbildenden Gasen vorgesehen.

Die folgenden Abschnitte enthalten alle erforderlichen Informationen, um die Sicherheit des Bedieners bei der Benutzung des Gerätes zu gewährleisten. Ausführliche Informationen befinden sich auf Seite 25 im Abschnitt "Technische Informationen".

Dieses Handbuch verwendet das folgende Standard-Sicherheitsprotokoll:

WARNUNG



Die Warnungsmeldungen dienen dazu, die Aufmerksamkeit des Bedieners auf ein bestimmtes Verfahren oder eine Methode zu lenken, deren inkorrekte Befolgung zu schweren Verletzungen führen kann.

VORSICHT



Die Vorsichtsmeldungen werden vor Verfahren angezeigt, deren Nichtbeachtung zur Beschädigung des Gerätes führen kann.

HINWEIS



Die Hinweise enthalten wichtige Informationen, die dem Text entnommen wurden.

Lagerung

Beim Transport und bei der Lagerung der Pumpe dürfen die folgenden Umgebungsbedingungen nicht überschritten werden:

Temperatur:	– 20 °C bis 60 °C (– 4 °F bis 140 °F)
Relative	
Feuchtigkeit:	0 bis 95 % (nicht kondensierend)

Auspacken und Inspektion

Beim Versandbehälter handelt es sich um einen doppelten Karton.

1. Entfernen Sie nach dem Öffnen des äußeren Kartons die Schaumverpackung.
2. Schneiden Sie den inneren Karton auf.
3. Heben Sie die Pumpe mit der Sperrholzunterlage aus dem inneren Karton heraus.
4. Entfernen Sie die vier Schrauben, mit denen der Pumpenrahmen an der Sperrholzunterlage befestigt ist.
5. Machen Sie das NW25 Auslass-Montageteil ausfindig und legen Sie es beiseite.
6. Prüfen Sie, ob die Pumpe beim Transport beschädigt worden ist.

Wenn Transportschäden vorhanden sein sollten, setzen Sie sich sofort mit dem Transportunternehmen und Ihrem lokalen Vacuum Technologies Verkaufsbüro in Verbindung.

7. Bewahren Sie den Karton und das Verpackungsmaterial auf.

Das Gesamtgewicht der Sendung, einschließlich der Pumpe, beträgt ungefähr 40 kg (87 lbs).

WARNUNG



Gehen Sie beim Auspacken der Pumpe vorsichtig vor, um das Gerät nicht fallen zu lassen, und vermeiden Sie jede Art von plötzlichen Stößen oder Erschütterungen.

WARNUNG



Die TriScroll 600 wiegt 32 kg (70 lbs). Benutzen Sie beim Heben und beim Transport der Pumpe geeignete Hebetechniken, um Verletzungen zu vermeiden.

HINWEIS



Normale Umgebungseinflüsse können die Pumpe nicht beschädigen. Trotzdem wird empfohlen, den Pumpeneinlass verschlossen zu halten, bis die Pumpe im System installiert wird.

Installationsanforderungen

Sicherheit

Sicherheits- oder Isolier Vorrichtungen dürfen nicht von der Pumpe entfernt oder modifiziert werden, da sonst schwerwiegende Sicherheitsrisiken entstehen und die Garantie ihre Gültigkeit verlieren kann.

WARNUNG



- ❑ Diese Pumpe ist ausschließlich zum Pumpen von Luft und inerten Gasen zu verwenden. Sie ist nicht zum Pumpen von explosiven, brennbaren, toxischen oder korrosiven Gasen vorgesehen. Diese können Verletzungen, Explosionen oder Feuer verursachen.
- ❑ Installieren Sie die Pumpe in einem Bereich, der keinem Regen, Dampf oder übermäßiger Feuchtigkeit ausgesetzt ist. Diese Umgebungsbedingungen können elektrische Schocks, Kurzschlüsse und schwere Verletzungen verursachen.
- ❑ Stellen Sie vor der Inspektion oder Wartung der Pumpe sicher, dass die Stromversorgung abgetrennt ist.
- ❑ Konsultieren Sie zum Verdrahten der Pumpe einen qualifizierten Elektriker.

VORSICHT



Obwohl die Pumpe Spurenpartikel pumpen kann, die normalerweise in der Atmosphäre zu finden sind, ist sie nicht für Feststoffe, Chemikalien, Pulver, Lösungsmittel, Kondensate oder andere Partikel vorgesehen. Diese können das Gerät beschädigen, seine Leistung herabsetzen oder seine Lebensdauer verkürzen.

Ein- und Dreiphasenpumpen operieren in Uhrzeigerrichtung, wenn Sie von der Motorseite aus betrachtet werden. (Beachten Sie den Pfeil auf dem Pumpenrahmen.) Eine inkorrekte Rotation kann zu permanenten Schäden an der Pumpe führen..

Während des Betriebes dürfen die folgenden Umgebungsbedingungen nicht überschritten werden:

Temperatur:	+ 5 °C bis + 40 °C (41 °F bis 104 °F)
Relative Feuchtigkeit:	0 bis 95 % (nicht kondensierend)

VORSICHT



Blockieren Sie nicht die Lüfter-Austrittskanäle, da sich die Pumpe sonst überhitzt. Eine Oberflächentemperatur der Pumpe von über 55 °C (131 °F) kann die Pumpe beschädigen. Wenn derartige Bedingungen beobachtet werden, schalten Sie die Pumpe ab und lassen Sie sie abkühlen. Nehmen Sie die Pumpe auseinander, überprüfen Sie, ob Schäden vorhanden sind und reparieren Sie diese gegebenenfalls.

VORSICHT



Die Konfiguration der Pumpe bei der Lieferung vom Werk ist in der folgenden Tabelle zu sehen. Überprüfen Sie, dass die Konfiguration der Versorgungsspannung entspricht.

Wenn eine Spannungsumstellung erforderlich ist, konfigurieren Sie die Spannung wie im Abschnitt "Elektrische Anschlüsse" auf Seite 28 und Seite 29 beschrieben.

TriScroll 600 Series Vacuum Pump

In Tabelle 3 sind die lieferbaren TS-600 Pumpenmodelle aufgeführt. Die Tabelle enthält außerdem Informationen zu den Spannungsversorgungskabeln, die mit jeder einzelnen Pumpe verwendet werden müssen.

Dreiphasenpumpen werden ohne Spannungsversorgungskabel geliefert. Ein Dreiphasen-Kabelsatz, Vacuum Technologies Teilenummer S4789001, ist lieferbar. Dieser Satz enthält keinen Stecker.

Tabelle 3 Pumpenmodelle und Versorgungskabel

Pumpenmodell	Motorspannung	Steckerart	Sicherung	Leitergröße	Kabelmarkierung	Kabellänge
PTS06001UNIV	100-115 VAC	NEMA 5-15P	-	14 Gage	UL/CSA	2,5 m
PTS06001UNIVEU	200-230 VAC	CEE 7/7	-	3x1,50 mm ²	<HAR>	2,5 m
PTS06001UNIVUK	200-230 VAC	BS 1363	BS 1362 13 Amp	3x1,50 mm ²	<HAR>	2,5 m
PTS06003UNIV	200-230 VAC	-	-	-	-	-
PTS06101UNIV	100-115 VAC	NEMA 5-15P	-	14 Gage	UL/CSA	2.5m
PTS06001UVPI	100-115 VAC	NEMA 5-15P	-	14 Gage	UL/CSA	2.5m

Stromunterbrecher

WARNUNG



Durch die Installation eines Unterbrechers der richtigen Kapazität werden Kurzschlüsse vermieden.

In Tabelle 4 ist die Kapazität der Stromunterbrecher aufgeführt, die für Pumpenmotoren verschiedener Spannungen für Ein- und Dreiphasenmotoren erforderlich sind.

Tabelle 4 Anforderungen an Stromunterbrecher

Einphasenmotor	100-115 VAC 50/60 Hz	200-230 VAC 50/60 Hz
Kapazität des Unterbrechers	20 Ampere	10 Ampere
Dreiphasenmoto	200-230 VAC	380-415-460 VAC
Kapazität des Unterbrechers	10 Ampere	5 Ampere

Betrieb

Um ein optimales Vakuum zu erreichen, muss die Pumpe für etwa eine Stunde mit abgedichtetem Einlass laufen.

Im Gegensatz zu herkömmlichen ölgekapselten Pumpen haben die trockenen Scroll-Pumpen von Vacuum Technologies keine Flüssigkeit, um sie von angesammeltem Staub und Ablagerungen zu reinigen. Lassen Sie die Pumpe periodisch für ein bis zwei Minuten bei Atmosphäre laufen, um sie auszuspülen. Spülen Sie die Pumpe regelmäßig aus und passen Sie diesen Zeitplan Ihren speziellen Bedingungen an.

Startverfahren

1. Stellen Sie sicher, dass das Isolationsventil des Vakuumsystems geschlossen ist.
2. Schalten Sie die Stromversorgung für die Pumpe ein.
3. Öffnen Sie das Isolationsventil.

Abschaltverfahren

1. Schließen Sie das Isolationsventil des Vakuumsystems. Dadurch wird verhindert, dass Ablagerungen aus der Pumpe in das Vakuumsystem transportiert werden.
2. Schalten Sie die Stromversorgung zur Pumpe ab.

Wartung

Das für den Betrieb und die Wartung der Pumpe zuständige Personal muss gut geschult und mit den Regeln zur Unfallvermeidung vertraut sein.

WARNUNG



- ❑ *o Der Kontakt mit hohen Spannungen kann zum Tod führen. Lassen Sie immer äußerste Vorsicht walten und beachten Sie die gültigen Vorschriften zur Unfallvermeidung.*
- ❑ *o Wenn die Maschine angeschaltet ist, muss besonders auf bewegliche Teile und hohe Spannungen geachtet werden.*
- ❑ *o Wenn Sie Wartungsarbeiten an der Pumpe durchführen müssen, nachdem diese für längere Zeit in Betrieb war, lassen Sie die Pumpe zuerst abkühlen, da die Temperatur der Außenfläche der Maschine 55 °C (131 °F) überschreiten kann.*
- ❑ *o Trennen Sie immer die Stromversorgung zur Pumpe ab, bevor Sie mit den Wartungsarbeiten beginnen.*

HINWEIS



Bevor Sie die Pumpe zur Reparatur an das Werk zurückschicken, muss das Blatt "Gesundheit und Sicherheit", das diesem Handbuch beigelegt ist, ausgefüllt und an das lokale Verkaufsbüro geschickt werden. Eine Kopie des Blattes muss vor dem Versand in die Verpackung der Pumpe eingelegt werden.

Wenn eine Pumpe beseitigt werden soll, muss dies in Übereinstimmung mit den speziellen nationalen und lokalen Normen erfolgen.

Instructions d'utilisation

Informations générales

Cet équipement est conçu pour être utilisé par des professionnels. L'utilisateur est tenu de lire ce manuel d'instructions ainsi que toutes les informations supplémentaires fournies par Vacuum Technologies avant de faire fonctionner l'équipement. Vacuum Technologies ne sera pas tenu responsable de tout incident se produisant en raison de la non observation de ces instructions, d'une utilisation incorrecte par un personnel non formé, d'une interférence non autorisée avec l'équipement, ou de toute action contraire à celles stipulées par les normes nationales appropriées.

La TriScroll™ 600 est une pompe à vide sèche de type « scroll ». Cette pompe peut être utilisée pour pomper de l'air ou des gaz inertes. Elle n'est pas prévue pour pomper des gaz toxiques, corrosifs, explosifs ou formant des particulates.

Les paragraphes suivants contiennent toutes les informations nécessaires pour garantir la sécurité de l'opérateur dans l'utilisation de cet équipement. Des informations détaillées sont fournies à la section « Informations techniques » à la page 25.

Ce manuel utilise le protocole des normes de sécurité suivant:

AVERTISSEMENT



Les messages d'avertissement visent à attirer l'attention de l'opérateur vis-à-vis d'une procédure ou pratique particulière, laquelle, si elle n'est pas observée correctement, pourrait entraîner des blessures graves

ATTENTION



Les messages d'attention sont affichés avant des procédures, lesquelles, si elles ne sont pas respectées, pourraient causer des dommages à l'équipement

REMARQUES



Les remarques contiennent des informations importantes prélevées du texte.

Stockage

Pendant le transport et le stockage de la pompe, les exigences environnementales suivantes ne doivent pas être dépassées :

Température : -20 °C à 60 °C (-4 °F à 140 °F)

Humidité relative : 0 à 95% (non-condensée)

Déballage et Inspection

Le conteneur d'expédition est un carton double.

1. Après l'ouverture de la boîte extérieure, retirez le bourrage de mousse.
2. Ouvrez la boîte intérieure à l'aide d'une lame.
3. Soulevez la pompe et la base de contreplaqué de la boîte intérieure.
4. Retirez les quatre écrous fixant le châssis de la pompe à la base de contreplaqué.
5. Repérez le raccord d'échappement NW25 et mettez-le de côté.
6. Contrôlez que la pompe n'est pas endommagée. Si la pompe a été endommagée durant le transport, contactez le transporteur et votre bureau de vente Vacuum Technologies local immédiatement.
7. Conservez le carton et le garnissage.

Le poids total du paquet, pompe comprise, est de 40 kg (87 livres) environ.

AVERTISSEMENT *Lorsque vous déballez la pompe, faites attention à ne pas la laisser tomber, et évitez tout impact soudain ou vibrations dues à des chocs.*



AVERTISSEMENT *La TriScroll 600 pèse 32 kg (70 livres). Pour éviter tout risque de blessures, utilisez des techniques de levage appropriées lorsque vous déplacez la pompe.*



REMARQUES *Une exposition normale à l'environnement n'endommagera pas la pompe. Toutefois, il est conseillé de tenir l'entrée de la pompe fermée jusqu'à ce que la pompe soit installée dans le système.*



Exigences d'installation

Sécurité

Ne retirez pas ni ne modifiez l'équipement de sécurité ou d'isolation de la pompe. Ceci pourrait représenter un risque important d'incendie et pourra invalider la garantie.

AVERTISSEMENT



Cette pompe est conçue pour pomper de l'air et des gaz inertes uniquement ; elle n'est pas conçue pour pomper des gaz explosifs, inflammables, toxiques ou corrosifs. Ceci pourrait représenter des risques de blessures corporelles, d'explosion ou d'incendie.

Installez dans une zone qui ne soit pas exposée à la pluie, à la vapeur ou à une humidité excessive. Ceci peut causer des chocs électriques, des courts-circuits ainsi que des blessures corporelles importantes.

Avant d'inspecter ou de réparer la pompe, assurez-vous que l'alimentation électrique a été déconnectée.

Consultez un électricien qualifié lorsque vous effectuez le câblage de la pompe.

ATTENTION



Bien que la pompe soit en mesure de pomper des particules traces se trouvant normalement dans l'atmosphère, elle n'est pas conçue pour traiter des solides, produits chimiques, poudres, solvants, condensats ou autres particules. Ces éléments peuvent endommager l'équipement, dégrader sa performance ou raccourcir sa durée de vie.

Les pompes monophasées et triphasées opèrent dans la direction des aiguilles d'une montre lorsque vues du côté moteur. (Notez la flèche sur le cadre de la pompe.) Une rotation incorrecte peut causer des dégâts permanents à la pompe.

TriScroll 600 Series Vacuum Pump

Pendant l'opération, les conditions environnementales suivantes ne doivent pas être dépassées :

Température : +5 °C à +40 °C (41 °F à 104 °F)

Humidité relative : 0 à 95% (non condensée)

ATTENTION



Ne bloquez pas les conduits de ventilation car la pompe peut surchauffer. Une température à la surface de la pompe supérieure à 55°C (131° F) est potentiellement dangereuse. Si de telles conditions sont observées, éteignez la pompe et laissez-la refroidir. Désassemblez, examinez les traces de dommages, puis réparez, si nécessaire.

ATTENTION



Lorsqu'elle est fournie par l'usine, la pompe est configurée tel qu'indiqué dans le tableau suivant. Vérifiez que la configuration correspond à la tension d'alimentation.

Si un changement de tension est requis, configurez la tension tel que décrit dans « Connexions électriques » à la page 28 et page 29.

Le Table 5 liste les modèles de pompes TS-600 disponibles et indique le câble devant être utilisé avec chaque pompe particulière.

Les pompes triphasées sont expédiées sans câble d'alimentation. Un jeu de câble d'alimentation triphasé, Vacuum Technologies pièce n° S4789001, est disponible. Ce jeu n'inclut pas de prise.

Table 5 Modèles de pompes et câbles

Modèle Pompe	Tension Moteur	Type Fiche	Fusibles	Taille Conducteur	Marquage Câble	Longueur Câble
PTS06001UNIV	100-115 VAC	NEMA 5-15P	-	14 Gage	UL/CSA	2,5 m
PTS06001UNIVEU	200-230 VAC	CEE 7/7	-	3x1,50 mm ²	<HAR>	2,5 m
PTS06001UNIVUK	200-230 VAC	BS 1363	BS 1362 13 Amp	3x1,50 mm ²	<HAR>	2,5 m
PTS06003UNIV	200-230 VAC	-	-	-	-	-
PTS06101UNIV	100-115 VAC	NEMA 5-15P	-	14 Gage	UL/CSA	2.5m
PTS06001UVPI	100-115 VAC	NEMA 5-15P	-	14 Gage	UL/CSA	2.5m

Coupe-circuits

AVERTISSEMENT



Protégez-vous contre les courts-circuits en installant un coupe-circuit de la capacité adéquate.

Table 6 indique la capacité des coupe-circuits requis pour les moteurs des pompes de différentes tensions, monophasés et triphasés.

Table 6 Exigences des coupe-circuits

Moteur monophasé	100-115 VAC 50/60 Hz	200-230 VAC 50/60 Hz
Capacité du coupe-circuit	20 Ampères	10 Ampères
Moteur triphasé	200-230 VAC	380-415-460 VAC
Capacité du coupe-circuit	10 Ampères	5 Ampères

Opération

Afin d'atteindre le vide complet, la pompe doit fonctionner pendant environ une heure avec l'entrée hermétiquement fermée.

À la différence des pompes à huile conventionnelles, les pompes sèches de type « scroll » Vacuum Technologies n'ont pas de fluides pour les débarrasser de la poussière et des débris accumulés. Faites fonctionner la pompe régulièrement à l'atmosphère pendant une minute ou deux pour vider la pompe. Nettoyez-la ainsi régulièrement et ajuster ce programme en fonction de vos conditions particulières.

Procédure de démarrage

1. Assurez-vous que la soupape d'isolation du système de vide est fermée.
2. Connectez la pompe à l'alimentation.
3. Ouvrez la soupape d'isolation.

Procédure d'arrêt

1. Fermez la soupape d'isolation du système de vide. Ceci empêche aux débris dans la pompe d'entrer dans le système de vide.
2. Déconnectez la pompe de l'alimentation.

Entretien

Le personnel responsable de l'opération et de l'entretien de la pompe doit être parfaitement formé et conscient des règles de prévention des accidents.

AVERTISSEMENT



- ❑ *Un contact avec des tensions élevées représente un danger de mort. Faites toujours très attention et observez les réglementations en vigueur sur la prévention des accidents.*
- ❑ *Lorsque la machine est alimentée, faites très attention aux pièces mobiles ainsi qu'aux tensions élevées.*
- ❑ *Si vous devez réaliser un travail d'entretien sur la pompe après une longue période d'opération, laissez la pompe refroidir car la température de la surface extérieure peut être supérieure à 55 °C (131 °F).*
- ❑ *Déconnectez toujours votre alimentation de la pompe avant de commencer tout travail d'entretien.*

REMARQUES



Avant de renvoyer la pompe à l'usine pour la faire réparer, la fiche de « Santé et Sécurité » attachée à ce manuel d'instruction doit être remplie et renvoyée au bureau de vente local. Une copie de la fiche doit être jointe au colis avant l'expédition.

Si une pompe doit être jetée, elle devra être détruite conformément aux normes nationales et locales appropriées.

Instrucciones de uso

Información general

Este equipo está diseñado para que lo utilicen profesionales. El usuario debería leer este manual de instrucciones y cualquier otra información adicional suministrada por Vacuum Technologies antes de trabajar con el equipo. Vacuum Technologies no se hará responsable de cualquier evento que pueda ocurrir debido al no cumplimiento con estas instrucciones, el uso inapropiado por personas no cualificadas, la interferencia no autorizada en el equipo, o cualquier otra acción contraria a lo establecido en las normativas nacionales específicas.

La TriScroll™ 600 es una bomba de vacío de sección descendente en seco. Esta bomba está preparada para el bombeo de aire o gases inertes. La bomba no está preparada para el bombeo de gases tóxicos, corrosivos, explosivos o que formen macropartículas.

Los siguientes párrafos contienen toda la información necesaria para garantizar la seguridad del operador mientras utilice el equipo. Si desea información más detallada, consulte la sección "Información técnica" en la página 25.

Este manual utiliza el siguiente protocolo estándar de seguridad:

ADVERTENCIA *Los mensajes de advertencia pretenden atraer la atención del operador sobre un procedimiento o práctica concreto, el cual, en caso de no seguirlo correctamente puede dar lugar a lesiones graves.*



PRECAUCIÓN *Los mensajes de precaución se muestran ante de procedimientos, que en caso de no seguirse podrían provocar daños a los equipos.*



NOTA *Las notas contienen información importante tomada del texto.*



Almacenaje

Cuando se transporte o almacene la bomba, no deberán superarse las siguientes condiciones ambientales:

Temperatura: -20 °C a 60 °C (-4 °F a 140 °F)

Humedad relativa: 0 a 95% (sin condensación)

Desembalaje e inspección

El embalaje de transporte es un cartón doble.

1. Tras abrir la caja exterior, retire la espuma protectora.
2. Abra la caja interior.
3. Saque la bomba con la base de madera contrachapada de la caja interior.
4. Retire los cuatro pernos que sujetan el bastidor de la bomba a la base de madera contrachapada.
5. Localice el racor de escape NW25 y déjelo a un lado.
6. Inspeccione cualquier posible daño de la bomba. Si hubiera algún daño producido en el transporte, póngase de inmediato en contacto con la empresa de transporte o las oficinas de ventas Vacuum Technologies.
7. Guarde el cartón y los materiales de embalaje.

El peso total del embalaje, incluyendo la bomba es de aproximadamente 40 kg (87 libras).

ADVERTENCIA *Al desembalar la bomba, asegúrese de no dejarla caer y evite cualquier tipo de impacto brusco o vibración que pueda afectarla.*



ADVERTENCIA *La bomba TriScroll 600 pesa 32 kg (70 libras). Para evitar lesiones, utilice las técnicas de izado adecuadas cuando transporte la bomba.*



NOTA *La exposición normal a entorno no dañará la bomba. Sin embargo, es aconsejable mantener la admisión de la bomba cerrada, hasta que ésta se instale en el sistema.*



Requisitos de instalación

Seguridad

No desmonte ni modifique ninguno de los equipos de seguridad o aislamiento presentes en la bomba. Si lo hiciera puede crear un grave riesgo de seguridad, pudiendo invalidar la garantía.

ADVERTENCIA



- ❑ Esta bomba está diseñada para bombear únicamente aire y gases inertes, no para bombear gases explosivos, tóxicos, inflamables o corrosivos. Estos últimos pueden provocar lesiones corporales, explosiones o incendios.
- ❑ Instale la bomba en una zona no expuesta a la lluvia, el vapor o a una humedad excesiva. Pueden provocar sacudidas eléctricas, cortocircuitos y graves lesiones.
- ❑ Antes de inspeccionar o realizar operaciones de mantenimiento en la bomba, asegúrese de que el suministro eléctrico está desconectado.
- ❑ Consulte con un electricista cualificado siempre que deba cablear la bomba.

PRECAUCIÓN



Aunque la bomba puede bombear micropartículas normalmente presentes en la atmósfera, no está diseñada para el proceso de sólidos, productos químicos, polvos, disolventes, condensados u otras macropartículas. Pueden dañar el equipo, degradar su rendimiento o acortar su vida útil.

Las bombas monofásicas y trifásicas funcionan en la dirección de las agujas del reloj vistas desde el extremo del motor. (Fíjese en la flecha situada en el bastidor de la propia bomba). Un giro inapropiado puede dañar de forma permanente la bomba.

Durante su funcionamiento, las siguientes condiciones ambientales no deben superarse:

Temperatura: +5 °C a +40 °C (41 °F a 104 °F)

Humedad relativa: 0 a 95% (sin condensación)

PRECAUCIÓN



No bloquee los conductos del ventilador ya que la bomba se sobrecalentaría. Una temperatura en la superficie de la bomba de más de 55°C (131 °F) es potencialmente perjudicial para la propia bomba. Si se observan dichas condiciones, desconecte la bomba y deje que se enfríe. Desmonte la bomba, inspecciónela en busca de posibles daños y repárela si fuera necesario.

PRECAUCIÓN



Tal como se suministra de fábrica, la bomba está configurada según la siguiente tabla. Verifique que la configuración se ajusta al voltaje de suministro.

Si se requiere un cambio de voltaje, configure el voltaje según se describe en el apartado "Conexiones eléctricas" de la página 28 y 29.

TriScroll 600 Series Vacuum Pump

La Tabla 7 enumera los modelos de bombas TS-600 disponibles e indica el cable de corriente que debe utilizarse con cada bomba en concreto.

Las bombas trifásicas se envían sin cable de corriente. Está disponible un kit de cable de corriente trifásico, con P/N de Vacuum Technologies S4789001. El kit no incluye la clavija.

Tabla 7 Modelos de bomba y cables de corriente

Modelo de bomba	Voltaje del motor	Tipo de clavija	Fusible	Tamaño del conductor	Cert. cable	Longitud cable
PTS06001UNIV	100-115 VAC	NEMA 5-15P	-	Calibre 14	UL/CSA	2.5 m
PTS06001UNIVEU	200-230 VAC	CEE 7/7	-	3x1.50 mm ²	<HAR>	2.5 m
PTS06001UNIVUK	200-230 VAC	BS 1363	BS 1362 13 Amp	3x1.50 mm ²	<HAR>	2.5 m
PTS06003UNIV	200-230 VAC	-	-	-	-	-
PTS06101UNIV	100-115 VAC	NEMA 5-15P	-	Calibre 14	UL/CSA	2.5m
PTS06001UVPI	100-115 VAC	NEMA 5-15P	-	Calibre 14	UL/CSA	2.5m

Disyuntores

ADVERTENCIA *Protéjase de los cortocircuitos instalando un disyuntor de la capacidad apropiada.*



La Tabla 8 enumera la capacidad del disyuntor requerida para los motores de bomba de varios voltajes, monofásicos y trifásicos.

Tabla 8 Requisitos del disyuntor

Motor monofásico	100-115 VAC 50/60 Hz	200-230 VAC 50/60 Hz
Capacidad del disyuntor	20 amperios	10 amperios
Motor trifásico	200-230 VAC	380-415-460 VAC
Capacidad del disyuntor	10 amperios	5 amperios

Funcionamiento

Para alcanzar el vacío máximo, la bomba debe dejarse en funcionamiento durante aproximadamente una hora con la admisión a la misma sellada.

A diferencia de las bombas convencionales de hermeticidad por aceite, las bombas de sección descendente en seco Vacuum Technologies no disponen de fluido para su limpieza en caso de acumulación de polvo y otros restos. Ponga en marcha de forma periódica en condiciones normales durante un minuto o dos para realizar un lavado de la bomba. Realice esta proceso de forma regular y ajuste el calendario de lavado a las condiciones concretas de trabajo.

Procedimiento de arranque

1. Asegúrese de que la válvula de aislamiento del sistema de vacío está cerrada.
2. Conecte la corriente eléctrica de la bomba.
3. Abra la válvula de aislamiento.

Procedimiento de parada

1. Cierre la válvula de aislamiento del sistema de vacío. Esto evita que los restos de la bomba pasen al sistema de vacío.
2. Desconecte la corriente eléctrica de la bomba.

Mantenimiento

El personal responsable del funcionamiento y mantenimiento de la bomba debe estar cualificado y ser consciente de las normativas de seguridad e higiene en el trabajo.

ADVERTENCIA



- ❑ *El contacto con alto voltaje puede provocar la muerte. Extremé las precauciones y tenga presente las normativas de seguridad e higiene.*
- ❑ *Cuando la máquina esté recibiendo alimentación eléctrica, tenga cuidado con las partes móviles y el alto voltaje.*
- ❑ *Si ha de realizarse una operación de mantenimiento en la bomba tras un periodo prolongado de funcionamiento, deje que la bomba se enfríe ya que la temperatura de la superficie exterior puede superar los 55°C (131°F).*
- ❑ *Desconecte siempre la alimentación eléctrica a la bomba antes de realizar cualquier trabajo de mantenimiento en la misma.*

NOTA



Antes de devolver a fábrica la bomba para su reparación, debe cumplimentar la hoja de "Seguridad e higiene" adjunta a este manual de instrucciones y enviarla a las oficinas de ventas locales. Una copia de la hoja debe introducirse en el embalaje de la bomba antes de enviarla a fábrica.

Si una bomba debe ser eliminada, debe hacerse siguiendo las normativas específicas, tanto nacionales como locales.

Istruzioni per l'uso

Informazioni generali

Quest'attrezzatura è stata progettata per personale specializzato. Prima di mettere in funzione l'attrezzatura, l'utente deve leggere questo manuale di istruzioni e le eventuali informazioni aggiuntive fornite dalla Vacuum Technologies. La Vacuum Technologies non sarà responsabile per eventuali danni causati dalla mancata osservanza di queste istruzioni, dall'utilizzo errato da parte di personale non addestrato, dalle interferenze non autorizzate con l'attrezzatura, o da qualsiasi azione contraria a quella prevista dagli specifici standard nazionali.

TriScroll™ 600 consiste di una pompa da vuoto a coclea a secco. Questa pompa è adatta per il pompaggio d'aria e di gas inerti. Non è invece adatta al pompaggio dei gas tossici, corrosivi, esplosivi o di formazioni particolari.

I seguenti paragrafi contengono tutte le informazioni necessarie per garantire la sicurezza dell'operatore durante l'utilizzo dell'attrezzatura. Informazioni più dettagliate sono riportate nella sezione "Informazioni Tecniche" a pagina 25.

Nel presente manuale è stato adottato il seguente protocollo standard di sicurezza:

AVVERTENZA



Questi messaggi servono ad attirare l'attenzione dell'operatore su una particolare procedura o prassi che, se non seguita correttamente, potrebbe causare serie lesioni.

ATTENZIONE



Questi messaggi vengono visualizzati prima della descrizione delle procedure e, se non osservati, potrebbero causare danni all'attrezzatura.

NOTA



Le note contengono importanti informazioni riprese dal testo

Conservazione

Durante il trasporto o la conservazione della pompa, è opportuno rispettare i seguenti requisiti ambientali:

Temperatura: da -20 °C a 60 °C (da -4 °F a 140 °F)

Umidità relativa: dallo 0 al 95% (non condensante)

Disimballaggio ed ispezione

Il contenitore di spedizione consiste in un doppio scatolone.

1. Dopo aver aperto lo scatolone esterno, rimuovere l'espanso d'imballaggio.
2. Praticare un taglio nel secondo scatolone per aprirlo.
3. Sollevare la pompa assieme alla base di compensato dallo scatolone interno.
4. Rimuovere i quattro bulloni che fissano il telaio della pompa alla base di compensato.
5. Individuare il dispositivo di fissaggio dello scarico NW25 e metterlo da parte.
6. Esaminare che non vi siano danni alla pompa. Nel caso si siano verificati danni durante la spedizione, contattare immediatamente lo spedizioniere e l'ufficio vendite Vacuum Technologies locale.
7. Conservare lo scatolone e il materiale d'imballaggio.

Il peso totale dell'imballaggio, compresa la pompa, è di circa 40 kg (87 libbre).

AVVERTENZA



Quando si disimballa la pompa, assicurarsi di non farla cadere, ed evitare che subisca qualsiasi improvviso impatto o forte vibrazione.

AVVERTENZA



La pompa TriScroll 600 pesa 32 kg (70 libbre). Per evitare infortuni, utilizzare le corrette tecniche di sollevamento quando si sposta la pompa.

NOTA



La normale esposizione agli agenti atmosferici non può danneggiare la pompa. Tuttavia, si consiglia di tenere l'ingresso della pompa chiuso fino a quando la pompa non viene installata nel sistema.

Requisiti per l'installazione

Sicurezza

Non rimuovere o modificare i sigilli di sicurezza o di isolamento dalla pompa perché potrebbero verificarsi incidenti e si potrebbe invalidare la garanzia.

AVVERTENZA



- ❑ Questa pompa è stata progettata per pompare aria e gas inerti; non è stata progettata per il pompaggio di gas esplosivi, infiammabili, tossici o corrosivi. Questi potrebbero causare lesioni, esplosioni o incendi.
- ❑ Installare la pompa in un luogo che non sia esposto alla pioggia, al vapore, o ad un'umidità eccessiva. Questi agenti potrebbero causare scosse elettriche, corto circuiti e severe lesioni.
- ❑ Prima di esaminare la pompa o di eseguirne la manutenzione, assicurarsi che l'alimentazione elettrica sia scollegata.
- ❑ Consultare un elettricista qualificato ogni qualvolta si effettua il cablaggio della pompa.

ATTENZIONE



Sebbene la pompa possa pompare particelle normalmente presenti nell'atmosfera, non è stata progettata per aspirare oggetti solidi, sostanze chimiche, polvere, solventi, condense o altre sostanze particellari. Queste possono danneggiare l'attrezzatura, menomarne le prestazioni o abbreviare la durata di utilizzazione.

Le pompe monofasi e trifasi funzionano in senso orario viste dall'estremità del motore. (Notare la freccia sul telaio della pompa). Una rotazione errata può causare danni permanenti alla pompa.

Durante il funzionamento, è opportuno rispettare i seguenti requisiti ambientali:

Temperatura: da +5 °C a +40 °C (da 41 °F a 104 °F)

Umidità relativa: dallo 0 al 95% (non condensante)

ATTENZIONE



Non bloccare i condotti della ventola poiché la pompa si potrebbe surriscaldare. Se la temperatura della superficie della pompa supera i 55°C (131°F), potrebbero verificarsi seri problemi. Nel caso si verificano tali condizioni, spegnere la pompa e lasciarla raffreddare. Smontarla, verificare che non vi siano danni e ripararli se necessario.

ATTENZIONE



Così come fornita dalla fabbrica, la pompa è configurata come illustrato nella seguente tabella. Verificare che la configurazione corrisponda alla tensione dell'alimentazione.

Qualora fosse necessario modificare la tensione, configurarla come descritto nella sezione "Collegamenti elettrici" a pagina 28 e 29.

TriScroll 600 Series Vacuum Pump

Nella tabella 9 sono elencati i modelli di pompe TS-600 e sono indicati i cavi di alimentazione da utilizzare con ogni particolare pompa.

Le pompe trifasi vengono spedite senza il cavo di alimentazione. È disponibile un kit di cavi di alimentazione trifase, Parte Vacuum Technologies n. S4789001. Questo kit non include una spina.

Tabella 9 Modelli di pompe e cavi di alimentazione

Pump Model	Motor Voltage	Plug Type	Fusing	Conductor Size	Cord Marking	Cord Length
PTS06001UNIV	100-115 VAC	NEMA 5-15P	-	14 Gage	UL/CSA	2,5 m
PTS06001UNIVEU	200-230 VAC	CEE 7/7	-	3x1,50 mm ²	<HAR>	2,5 m
PTS06001UNIVUK	200-230 VAC	BS 1363	BS 1362 13 Ampere	3x1,50 mm ²	<HAR>	2,5 m
PTS06003UNIV	200-230 VAC	-	-	-	-	-
PTS06101UNIV	100-115 VAC	NEMA 5-15P	-	14 Gage	UL/CSA	2.5m
PTS06001UVPI	100-115 VAC	NEMA 5-15P	-	14 Gage	UL/CSA	2.5m

Interruttori automatici

AVVERTENZA *Proteggere dai corto circuiti installando un interruttore automatico della giusta capacità..*



Nella Tabella 10 sono elencati gli interruttori automatici richiesti per i motori delle pompe di varie tensioni, monofasi e trifasi.

Tabella 10 Requisiti dell'interruttore automatico

Motore monofase	100-115 VAC 50/60 Hz	200-230 VAC 50/60 Hz
Capacità dell'interruttore	20 Ampere	10 Ampere
Motore trifase	200-230 VAC	380-415-460 VAC
Capacità dell'interruttore	10 Ampere	5 Ampere

Funzionamento

Al fine di raggiungere il vuoto massimo, la pompa deve funzionare per circa un'ora con l'ingresso sigillato.

A differenza delle pompe convenzionali a tenuta d'olio, le pompe a coclea a secco della Vacuum Technologies non hanno un fluido che le ripulisca da polvere e detriti accumulati. Per pulirla, far funzionare la pompa periodicamente ad atmosfera per un minuto o due. Lavare la pompa regolarmente e regolare questo programma secondo le specifiche condizioni.

Procedura per l'avviamento

1. Assicurarsi che la valvola d'isolamento del sistema a vuoto sia chiusa.
2. Inserire l'alimentazione della pompa.
3. Aprire la valvola d'isolamento.

Procedura per lo spegnimento

1. Chiudere la valvola d'isolamento del sistema a vuoto. Questo impedisce che i detriti presenti nella pompa vengano trasportati nel sistema a vuoto.
2. Disinserire l'alimentazione della pompa..

Manutenzione

Il personale responsabile del funzionamento e della manutenzione della pompa deve essere ben addestrato e deve conoscere le regole per la prevenzione di incidenti.

AVVERTENZA



- ❑ *Il contatto con l'alta tensione potrebbe causare lesioni mortali. Prestare sempre estrema attenzione ed osservare le regole per la prevenzione di incidenti in vigore.*
- ❑ *Quando la macchina è accesa, fare attenzione alle parti in movimento e alle alte tensioni.*
- ❑ *Se si deve eseguire la manutenzione della pompa dopo un considerevole lasso di tempo, lasciare che la pompa si raffreddi poiché la temperatura della superficie esterna potrebbe superare i 55°C (131°F).*
- ❑ *Scollegare sempre l'alimentazione della pompa prima di iniziare il processo di manutenzione.*

NOTA



Prima di restituire la pompa alla fabbrica per eventuali riparazioni, è necessario completare ed inviare all'ufficio vendite locale il modulo "Salute e Sicurezza" allegato al presente manuale di istruzioni. Una copia del suddetto modulo deve essere inclusa nell'imballaggio della pompa prima della spedizione.

L'eventuale smaltimento della pompa deve avvenire in conformità con gli specifici standard nazionali e locali.

使用仕様

概況概要

この設備は専門者に向っている。ユーザーはこの設備を操作する前にこの取付仕様書及び Vacuum Technologies の提供する他の追加情報を良く読まなければならない。これらの仕様に遵守しないこと、訓練されていない人に間違っ使用されること、許可されずにこの設備の運転を妨げること、或は特定の国家標準にある操作規範と相違して操作することによる如何なる事故に対して、Vacuum Technologies は責任を負わない。

この TriScroll™ 600 はスクロール型ドライ真空ポンプである。このようなポンプは空気と希ガスに適用する。しかし、有毒ガス、腐食性ガス、爆発性ガス或は微粒子ガスに適用しない。

次の節にこの設備を使用する時の操作者の安全保障に関するすべての必要情報を含む。詳細はページ 25 の「技術情報」を参考してください。

この仕様書は次の標準安全プロトコルを採用する：

警告  警告は操作者に特定の操作手順とオペレーションを注意させる内容を示す。その内容を無視すると重大損傷の可能性がある。

注意  注意内容は手順の前に示す。注意内容を無視すると設備損害の可能性が有る。

注  マニュアルから摘録される重要情報を含む。

保存

ポンプを運送保存する場合は次の環境要求を適わなければならない。

温度： -20 °C ~ 60 °C (-4 °F ~ 140 °F)
 相対湿度： 0 ~ 95% (凝結物無し)

開梱と点検

梱包箱は二重ダンボールである。

1. 外部梱包箱を開けた後、フォームプラスチックを取外す。
2. 内部梱包箱を切り開く。
3. ベニヤ板の台座でポンプを内部梱包箱から取外す。
4. ポンプフレームをしっかりと固定する為のベニヤ板にある四つのボルトを取外す。
5. NW25 排気管のコネクターを見出して、傍に置く。
6. ポンプが損害されたか否かを点検する。
 運送損害がある場合、すぐ運搬会社と地元の Vacuum Technologies 販売事務所と連絡してください。
7. ダンボールと梱包材料を保留してください。

ポンプを含む梱包の総重量は約 40 キロである。(87 ポンド)

警告  ポンプの梱包を開ける時は、ポンプが落ちないことを確認してください。且つ、突然のインパクトとショックを避けてください。

警告  TriScroll 600 の重さは 32 キロである (70 ポンド)。損害をもたらさない為にポンプを移動する時は正しい持ち上げる技術を採用してください。

注  正常の場合は、環境にポンプを露出すると破損を誘発できる。システムの中にポンプを取り付ける前にポンプ入口を密封する状況を保持してください。

取付要求

安全

安全設備と絶縁設備を取外す或は修正しないでください。そうすると、重大の安全危険と修理保証の無効を誘発する可能性がある。



- このポンプは空気と希望ガスのみにも適用する。爆発性ガス、可燃性ガス、有毒ガス或は腐食性ガスに適用しない。そうすると、人間への損傷、爆発或は火事を誘発する可能性がある。
- 取付場所は雨水、蒸気或は多すぎる湿気に影響されやすすくないところにする。そうしないと、電撃、ショートと身体傷害を誘発する可能性がある。
- ポンプを点検と修理する前に、ポンプの電源をカットオフすることを確認してください。
- ポンプの配線する場合は、電気認可技師に問い合わせてください。

注意



このポンプが普通に空気にある微粒子を汲み出すことができるが、固体、化学製品、粉状物、溶剤、凝縮物或は他の微粒子物を汲み出すために設計されないの、このような物は設備を損害して、設備の性能が低下して、その使用期限を短縮する可能性がある。

電動機の側からみると、単相誘導電動機と三相誘導電動機が時計回りに回転するはずである。(ポンプフレームにある矢印を注意してください) 正しく回転しないとポンプを永久的に損害する可能性がある。

操作する時は以下の環境要求を適わなければならない。

温度 : +5 °C ~ +40 °C
(5.00 °C ~ 40.00 °C)

相対湿度 : 0 ~ 95%
(凝結物無し)

注意



空気回路を塞げないでください。塞がるとポンプの温度が高すぎるようになる。ポンプの表面温度が 55 °C (131 °F) 以上になると損害を誘発する可能性がある。したがって、このような状況を発見するとポンプをオフして、冷却させる。必要な場合はポンプを取外して、点検と修理してください。

注意



工場からの設定は以下に表のようである。この設定が電源と一致するかどうかと点検してください。

電圧を変更する必要がある場合、ページ28とページ29の「電気接続」のように電圧を設定する。

TriScroll 600 Series Vacuum Pump

表 11 に利用可能な TS-600 ポンプの型式を示す。また、特定ポンプの電源コードを指定する。

三相誘発ポンプは電源コードが付かないが、Vacuum Technologies 部品の番号が S4789001 である三相電源コードキットを配置する。このキットにはプラグを含まない。

表 11 ポンプ型式と電源コード

ポンプ型	電動機電圧	プラグ型式	溶解切断	コンダクターサイズ	コードマーク	コード長さ
PTS06001UNIV	100-115 VAC	NEMA 5-15P	-	14 Gage	UL/CSA	2.5 m
PTS06001UNIVEU	200-230 VAC	CEE 7/7	-	3x1.50 mm ²	<HAR>	2.5 m
PTS06001UNIVUK	200-230 VAC	BS 1363	BS 1362 13 Amp	3x1.50 mm ²	<HAR>	2.5 m
PTS06003UNIV	200-230 VAC	-	-	-	-	-
PTS06101UNIV	100-115 VAC	NEMA 5-15P	-	14 Gage	UL/CSA	2.5m
PTS06001UVPI	100-115 VAC	NEMA 5-15P	-	14 Gage	UL/CSA	2.5m

回路遮断器

警告



適切な遮断器を取り付けることによって、ショートを防止する。

表 12 は各種の電圧で単相と三相ポンプ用電動機の遮断器の必要容量をあげる。

表 12 遮断器の要求

単相誘発電動機	100-115 VAC 50/60 Hz	200-230 VAC 50/60 Hz
遮断器の必要容量	20 Amperes	10 Amperes
三相誘発電動機	200-230 VAC	380-415-460 VAC
遮断器の必要容量	10 Amperes	5 Amperes

操作

到達真空を実現する為に、ポンプの入口を密封した場合にポンプに約1時間ほど続いて運転させてください。

従来の油回転（真空）ポンプと違って、Vacuum Technologies のスクロール型ドライ真空ポンプは液体で蓄積される塵と破片を浄化する必要がない。空気的环境中で一分或は二分ほどポンプを運転するとポンプのクリーニングを実現できる。定期的にポンプを浄化してください。特定の状況に応じて、この時間を調整してください。

スタートアップ手順

1. 真空システムの遮断弁を閉めたことを確認する。
2. ポンプの電源を ON にする。
3. ポンプの遮断弁を開ける。

シャットダウン手順

1. 真空システムの遮断弁を閉める。これによって、破片が真空システムまで運搬されて、ポンプに入ることを防止できる。
2. ポンプの電源を ON にする。

保守

操作と保守の担当者は厳しく訓練されなければならない。そして、事故防止規則を精通しなければならない。

警告



- 高圧と接すると電撃死亡になる可能性があるため、いつも有効的の事故防止規則を遵守しなければならない。
- 通電した後、部品を移動する場合はよく注意して、特に高圧を注意してください。
- ポンプが長時間ほど運転した後に保守しないと、その表面温度が 65°C (131°F) 以上になる可能性があるため、冷却された後保守してください。
- 保守を始める前にいつもポンプの電源を OFF にしてください。

注



工場にポンプを返還して修理を要求する前に、この仕様書付きの「健康と安全」表を記入して、地元の販売事務所へ郵送してください。運搬運送される前にこの表の写しをポンプパッケージの中においてください。

ポンプを廃棄する場合、特定の国家と地方標準によって処理しなければならない。

使用说明

一般信息

本设备供专业人员使用。用户在操作本设备之前应阅读此安装手册以及 Vacuum Technologies 提供的任何其它附加说明。对于因不遵照这些说明、未经培训人员不当地使用、未经授权而擅自干扰本设备操作或执行与特定国家标准要求的操作相违反的操作而导致的任何事故，Vacuum Technologies 概不负责。

该 TriScroll™ 600 为干涡管真空泵。此泵适用于泵送空气或惰性气体。该泵不用于泵送有毒气体、腐蚀性气体、爆炸性气体或含颗粒状物质气体。

以下章节提供使用本设备时确保操作人员安全的所有必需信息。有关详细信息，请参阅第 25 页“Technical Information”。

本手册采用以下标准安全体例：

警告
 警告消息用于提请操作人员注意特定的操作步骤或实际操作，如果不严格按照指导操作，可能会导致严重人身损伤。

注意
 注意消息显示在操作步骤之前，如果不遵照注意消息的指导，可能会损坏设备。

注释
 注释包含从文本中提取的重要信息。

存放

在运输和存放该泵时，不应超出以下环境要求：

温度： -20 °C 至 60 °C (-4 °F 至 140 °F)
相对湿度： 0 至 95% (不冷凝)

开箱和检查

包装箱为双层纸箱。

1. 打开外包装箱后，取出泡沫包装。
2. 切开内包装箱。
3. 通过胶合板基座将泵抬出内包装箱。
4. 卸下将泵架紧固至胶合板基座的四颗螺栓。
5. 找到 NW25 排气管接头并将其置于一边。
6. 检查泵是否在运输中遭受损坏。

如果发现任何运输中造成的损坏，请立即与承运商和您当地的 Vacuum Technologies 销售办事处联系。

7. 保留纸箱和包装材料。

包括泵在内的包装总重量大约为 40 公斤 (87 磅)。

警告
 打开泵包装时，确保不要将泵跌落，并且避免不要突然碰撞或冲击振动泵体。

警告
 TriScroll 600 重 32 公斤 (70 磅)。为避免造成损伤，在移动泵时，请使用适当的起重装置。

注释
 正常情况下，将泵暴露于环境中不会对其造成损坏。不过，建议在系统中安装泵之前，将泵吸入口保持为密封状态。

安装要求

安全

请勿拆卸或改动泵中的任何安全或绝缘装置。否则，可能会造成严重的安全隐患并可能使保修失效。

警告



- ❑ 此泵仅用于泵送空气和惰性气体，不用于泵送爆炸性气体、易燃气体、有毒气体或腐蚀性气体。否则，可能导致人身伤害、爆炸或火灾。
- ❑ 安装场所不能易遭受雨淋、蒸汽或湿度过高。否则，可能导致电击、短路和严重的人身伤害。
- ❑ 在检查或维修泵之前，确保断开泵的电
- ❑ 每当对泵进行布线时，请咨询合格的电气技师。

注意



尽管该泵可以泵送大气中通常存在的颗粒状物质，但是它并非设计用于处理固体、化学制品、粉状物质、溶剂、冷凝物或其它颗粒状物质。这些物质可能会损坏设备、降低设备性能或缩短其使用寿命。

从电动机一端观看时，单相和三相泵应以顺时针方向运转。（请注意泵架上的箭头。）如果旋转方向不正确，可能会对泵造成永久性损坏。

操作期间，不应超出以下环境条件：

温度： +5 °C 至 +40 °C (41 °F 至 104 °F)
相对湿度： 0 至 95% (不冷凝)

注意



请勿阻塞风道，否则可能会造成泵的温度过高。泵的表面温度若超过 55 °C (131 °F) 就有可能造成损坏。如果观察到此类情况，请关闭泵并允许其冷却。必要时，请拆卸泵、检查是否损坏并进行修理。

注意



泵出厂时的配置如下表所示。请检查此配置是否与您当地的电源电压相匹配。

如果需要转换电压，请按第 28 页和第 29 页“Electrical Connections”中的说明配置电压。

TriScroll 600 Series Vacuum Pump

表 13 列出了可用的 TS-600 泵型号，并指出每种特定泵使用的电源电缆。

三相泵未随附电源电缆。可向客户提供 Vacuum Technologies 部件号为 S4789001 的三相电源电缆套件。此套件不包括插头。

表 13 泵型号和电源电缆

泵型号	电动机 电压	插头类型	熔断	导体尺寸	电缆标记	电缆长度
PTS06001UNIV	100-115 VAC	NEMA 5-15P	-	14 号标准直径	UL/CSA	2.5 米
PTS06001UNIVEU	200-230 VAC	CEE 7/7	-	3x1.50 毫米 ²	<HAR>	2.5 米
PTS06001UNIVUK	200-230 VAC	BS 1363	BS 1362 13 安培	3x1.50 毫米 ²	<HAR>	2.5 米
PTS06003UNIV	200-230 VAC	-	-	-	-	-
PTS06101UNIV	100-115 VAC	NEMA 5-15P	-	14 ½Y±1P ⁰ ±æ ¹	UL/CSA	2.5m
PTS06001UVPI	100-115 VAC	NEMA 5-15P	-	14 ½Y±1P ⁰ ±æ ¹	UL/CSA	2.5m

断路器

警告

通过安装适当容量的断路器以防止短路。



表 14 列出了各种电压单相和三相泵用电动机所需的断路器容量。

表 14 断路器要求

单相电动机	100-115 VAC 50/60 Hz	200-230 VAC 50/60 Hz
断路器容量	20 安培	10 安培
三相电动机	200-230 VAC	380-415-460 VAC
断路器容量	10 安培	5 安培

操作

为了实现极限真空，必须在密封泵吸入口的情况下使泵保持运行大约一小时的时间。

与传统油封泵不同的是，Vacuum Technologies 的干涡管泵无需使用液体冲洗其中所沉积的灰尘和碎屑。在大气环境中定期运行泵一或两分钟即可实现对泵的清洁。定期冲洗泵并根据特定情况调整此时间安排。

启动过程

1. 确保关闭真空系统隔离阀。
2. 打开泵的电 源。
3. 打开隔离阀。

关机过程

1. 关闭真空系统隔离阀。这可以防止碎屑由于传送至真空系统而进入泵体内。
2. 关闭泵的电 源。

维护

负责操作和维护泵的人员必须经过严格的培训，并且熟悉事故预防规则。

警告



- ❑ 接触高压可能会遭受电击而致死。应始终格外小心并遵循有效的事故预防规程。
- ❑ 机器通电后，须特别小心移动部件并注意高压。
- ❑ 如果必须在泵操作相当长的时间之后对其进行维护，请等其冷却后再操作，因为外表面的温度可能超过 55 °C (131 °F)。
- ❑ 在开始维护工作之前，始终断开泵的电 源。

注释



将泵返回工厂维修之前，必须填写本说明手册随附的“健康和安 全”表，并将其发送至当地销售办事处。运输之前，必须将该表的副本插入泵的包装箱内。

如果要废弃泵，必须按照特定的国家和当地标准对其进行处置。

사용설명

일반정보

본 설비는 전문인원 사용으로 제공됩니다. 사용자는 본 설비를 조작하시기 전에 본 설치 안내서 및 Vacuum Technologies 에서 제공한 기타 모든 추가정보들을 읽으셔야 합니다. 이러한 설명에 따르지 않았거나 훈련 받지 않은 인원의 부적합 사용, 마음대로 본 설비에 지장을 주거나 특정국가의 표준을 위하여 제공한 조작과 반대인 조작으로 인한 임의의 사고에 대하여 Vacuum Technologies 에서는 어떠한 책임도 지지 않습니다.

본 TriScroll™ 600 은 건조 소용돌이 진공펌프입니다. 본 펌프는 공기나 불활성 기체를 펌핑하는 데 적용됩니다. 본 펌프는 유독 기체, 부식성 기체, 폭발성 기체 및 미립성 기체를 펌핑하는 데 사용하지 않습니다.

하기의 내용에는 본 설비의 사용중에 조작인원의 안전을 보장하는 모든 필수정보가 포함되어 있습니다. 관련 상세한 정보는 제 25 페이지의 "기술정보" 를 참고로 하여 주십시오.

본 안내서는 하기의 안전협의 표준에 부합됩니다:

경고

 경고메시지는 조작인원으로 하여금 특정한 조작절차나 실지조작에 주의를 돌리게 하기 위한 것으로서 엄격히 지키지 아니하면 심한 손상을 초래할 수 있습니다.

주의

 주의메시지는 조작절차 전에 주의소식에 따라 조작하지 아니하면 설비를 파손할 수 있다는 것을 알려 줍니다.

주석

 주석은 본문에서 취한 중요한 정보를 포함합니다.

보관

본 펌프를 운송 및 보관 시 하기의 환경 요구의 한계를 넘지 않아 주십시오:

- 온도 : -20 °C 에서 60 °C 까지
 (-4 °F 에서 140 °F 까지)
- 상대습도 : 0 에서 95% 까지
 (응축하지 않음)

포장 열기 및 검사

포장 박스는 두 층으로 된 종이 박스입니다.

1. 겉 포장을 연 후 플라스틱 발포 포장을 꺼냅니다.
2. 내부 포장을 잘라 냅니다.
3. 베니어판을 이용하여 내부 박스에서 펌프를 들어냅니다.
4. 펌프 틀과 베니어판을 고정시킨 네개 볼트를 제거합니다.
5. NW25 배기장치 플러그를 찾아내어 옆에 둡니다.
6. 펌프에 파손이 있는 가 검사합니다.
 운송과정에 파손이 있을 경우 즉시 운수회사 및 현지 Vacuum Technologies 대리점에 연락하십시오.
7. 종이 박스와 포장재료를 보관하여 주십시오.

펌프를 포함한 포장의 총 중량은 약 40 킬로 입니다 (87 파운드).

경고

 펌프의 포장을 뜯을 때 펌프를 떨어뜨리는 것을 삼가시고 펌프를 갑자기 충돌, 진동하는 것을 피하여 주십시오.

경고

 TriScroll 600 의 무게는 32 킬로에 달합니다 (70 파운드). 파손을 피하기 위하여 펌프를 이동 시 정확한 기중기술을 사용하십시오.

주석

 일반상황에서 펌프는 환경 중에 드러나도 파손 되지 않습니다. 하지만 펌프를 설치하기 전 펌프의 흡입구의 밀폐상태를 유지할 것을 권의합니다.

설치요구

안전장치

펌프의 임의의 안전 및 절연장치를 뜯어내거나 고치지 말아 주십시오. 그렇지 아니할 경우에는 심한 사고를 빚어 낼 가능성이 있으며 품질 보증이 효력을 잃을 가능성이 있습니다.

경고



- 본 펌프는 공기나 불활성 기체를 펌핑하는 데 적용되고 유독 기체, 부식성 기체, 폭발성 기체를 펌핑하는 데 사용하지 않습니다. 이러한 기체들은 인신상해, 폭발 및 화재를 일으킬 수 있습니다.
- 설치장소는 비에 쉽게 젖는, 수증기 및 습기의 영향을 많이 받는 장소가 아니어야 합니다. 그들은 감전, 단락과 인신상해를 초래할 수 있습니다.
- 펌프를 검사 및 수리 할 때 펌프의 전원을 끊어야 합니다.
- 펌프에 대하여 배선을 진행할 때 전기 기술자에게 자문하여 주십시오.

주의



비록 본 펌프는 대기 중에 보편적으로 존재하는 미립성 물체를 펌핑할 수 있지만 고체, 화학제품, 분말 물질, 용제, 응축물 및 기타 미립성 물체에 사용하지 않도록 설계한 것입니다.

발동기 쪽에서 볼 때 단상과 삼상은 시계방향으로 운전하여야 합니다. (펌프 틀에 있는 화살표를 주의하여 주십시오.) 회전이 정확하지 않을 경우 영구성 파손을 초래할 수 있습니다.

조작기간에 하기의 환경요구를 넘지 말아 주십시오 :

온도 : +5 °C 에서 +40 °C 까지
(41 °F 에서 104 °F 까지)

상대습도 : 0 에서 95% 까지
(응축하지 않음)

주의



바람덕트를 막지 말아 주십시오. 그렇지 아니할 경우 펌프의 온도가 너무 높아질 수 있습니다. 펌프의 표면온도가 55 °C (131 °F) 를 넘으면 파손될 위험이 있습니다. 이러한 상황을 발견하면 펌프를 정지하여 냉각시켜야 합니다. 필요 시 펌프를 뜯어서 파손이 있는가를 검사하고 수리하여야 합니다.

주의



펌프가 제조상으로부터 출하 시의 배치는 아래의 표와 같습니다. 이러한 배치와 전원전압과의 부합여부를 검사하십시오.

전압의 전환이 필요 시 제 28 과 29 페이지의 " 전기연결 " 중의 설명에 따라 전원을 설치하십시오.

TriScroll 600 Series Vacuum Pump

표 15에서는 사용이 가능한 TS-600 펌프 모델과 매개 특성 펌프에 사용되는 코드를 기록하였습니다.

삼상펌프에는 코드가 함께 들어있지 않고 Vacuum Technologies 부품번호가 S4789001인 삼상전원 케이블공구세트를 제공하였습니다. 이 세트에는 플러그가 포함되지 않습니다.

표 15 펌프모델 및 코드

펌프모델	발동기전압	플러그유형	퓨징	도체사이즈	코드 표기	코드 길이
PTS06001UNIV	100-115 VAC	NEMA 5-15P	-	14 Gage	UL/CSA	2.5 m
PTS06001UNIVEU	200-230 VAC	CEE 7/7	-	3x1.50 mm ²	<HAR>	2.5 m
PTS06001UNIVUK	200-230 VAC	BS 1363	BS 1362 13 Amp	3x1.50 mm ²	<HAR>	2.5 m
PTS06003UNIV	200-230 VAC	-	-	-	-	-
PTS06101UNIV	100-115 VAC	NEMA 5-15P	-	14 Gage	UL/CSA	2.5m
PTS06001UVPI	100-115 VAC	NEMA 5-15P	-	14 Gage	UL/CSA	2.5m

브레이커

경고



적당한 용량의 브레이커를 설치하여 단락을 방지하여야 합니다.

표 16에서는 각종 전압의 단상과 삼상 펌프용 발동기가 수요하는 브레이커 용량을 열거하였습니다.

표 16 브레이커 요구

단상발동기	100-115 VAC 50/60 Hz	200-230 VAC 50/60 Hz
브레이커 용량	20 Amperes	10 Amperes
삼상발동기	200-230 VAC	380-415-460 VAC
브레이커 용량	10 Amperes	5 Amperes

조작

극한 진공을 실현하기 위하여 반드시 펌프 흡입구를 밀폐한 상태에서 펌프를 약 한 시간 가량 운행하여야 합니다 .

전통적인 기름밀폐 펌프와 상이한 점은 Vacuum Technologies 의 건조 소용돌이 펌프는 액체를 사용하여 그 중에 누적된 먼지와 부스러기를 세척할 필요가 없습니다 . 대기 환경 중에서 정기적으로 펌프를 1-2 분간 운행하면 펌프에 대한 세척을 완성할 수 있습니다 . 정기적으로 펌프를 세척하고 특정 상황에 따라 이 시간 안배를 조절합니다 .

시동과정

1. 진공시스템 격리 밸브가 닫힌 것을 확인합니다 .
2. 펌프에 전력을 공급합니다 .
3. 격리밸브를 엽니다 .

중단과정

1. 진공 시스템 격리 밸브를 닫습니다 . 이것은 부스러기가 진공 시스템에 전송되어 펌프에 들어가는 것을 방지합니다 .
2. 펌프의 전원을 끕니다 .

유지

펌프를 조작 , 유지하는 인원은 엄격한 훈련을 거쳐야 하고 사고 방지 규칙에 익숙하여야 합니다 .

경고



- 고압전기를 접촉하면 감전되어 사망을 초래할 수 있습니다 . 시중 효과적인 사고방지 규정에 따라 특별히 조심하여 주십시오 .
- 기계에 전력을 공급한 후 부품을 이동 시 조심하며 고압전기에 주의하여 주십시오 .
- 반드시 펌프가 상당한 시간을 작동 후에 수리하여야 할 경우 냉각된 후 다시 조작하여 주십시오 . 그것은 그때의 표면의 온도가 55 °C (131 °F) 를 넘을 수 있기 때문입니다 .
- 유지 작업을 시작 하기 전에 항상 전원을 ED 어 주십시오 .

주석



주석펌프를 제조상에 반환하여 수리하기 전에는 반드시 본 설명 안내서와 함께 드린 " 건강 및 안전 " 안내서를 써넣어서 현지 대리점에 보내 주십시오 . 운송 전에 반드시 이 표의 부분을 펌프의 포장 속에 넣어 주십시오 .

펌프를 폐기할 경우 반드시 나라와 현지의 기준에 따라 처치하여야 합니다 .

Technical Information

Table 17 Specifications

Model	TriScroll™ 600 Series Dry Scroll Vacuum Pump
Interface dimensions	See Figure 1
Peak pumping speed	50 Hz: 420 l/m, 25.2 m ³ /hr (14.8 cfm) 60 Hz: 500 l/m, 30 m ³ /hr (17.7 cfm)
Media	Clean air. No toxic, corrosive, explosive or particulate forming gases
Ultimate pressure (Torr)	7.0 x 10 ⁻³ Torr (9.3 x 10 ⁻³ mbar)
Maximum inlet pressure	1.0 atmosphere (0 psig)
Maximum outlet pressure	1.1 atmosphere (1.5 psig)
Inlet connection	NW40
Exhaust connection	Female 3/8" National Pipe Thread (NW25 adapter provided)
Gas ballast	Female 1/4" National Pipe Thread (40 Micron sintered filter provided)
Ambient operating temperature	5 °C to 40 °C (41 °F to 104 °F)
Storage temperature	-20 °C to 60 °C (-4 °F to 140 °F)
Motor rating	1.0 HP (0.76 kW)
Operating voltages	Single phase models: <input type="checkbox"/> 50-60 Hz/100-115:200-230 VAC Three phase models: <input type="checkbox"/> 50 Hz/200-230:380-415 VAC <input type="checkbox"/> 60 Hz/200-230:460 VAC
Motor full load currents	See Table 18 on page 36
Motor thermal protection	Type U automatic
Operating speed	60 Hz: 1725 RPM, 50 Hz: 1425 RPM
Cooling system	Air-cooled
Weight	Pump only: 32 kg (70 lbs) Shipping weight: 40 kg (87 lbs)
Noise level (per ISO 11201)	68 dB(A)
Vibration level at inlet (per ISO 10816-1)	6.3 mm/sec

TriScroll 600 Series Vacuum Pump

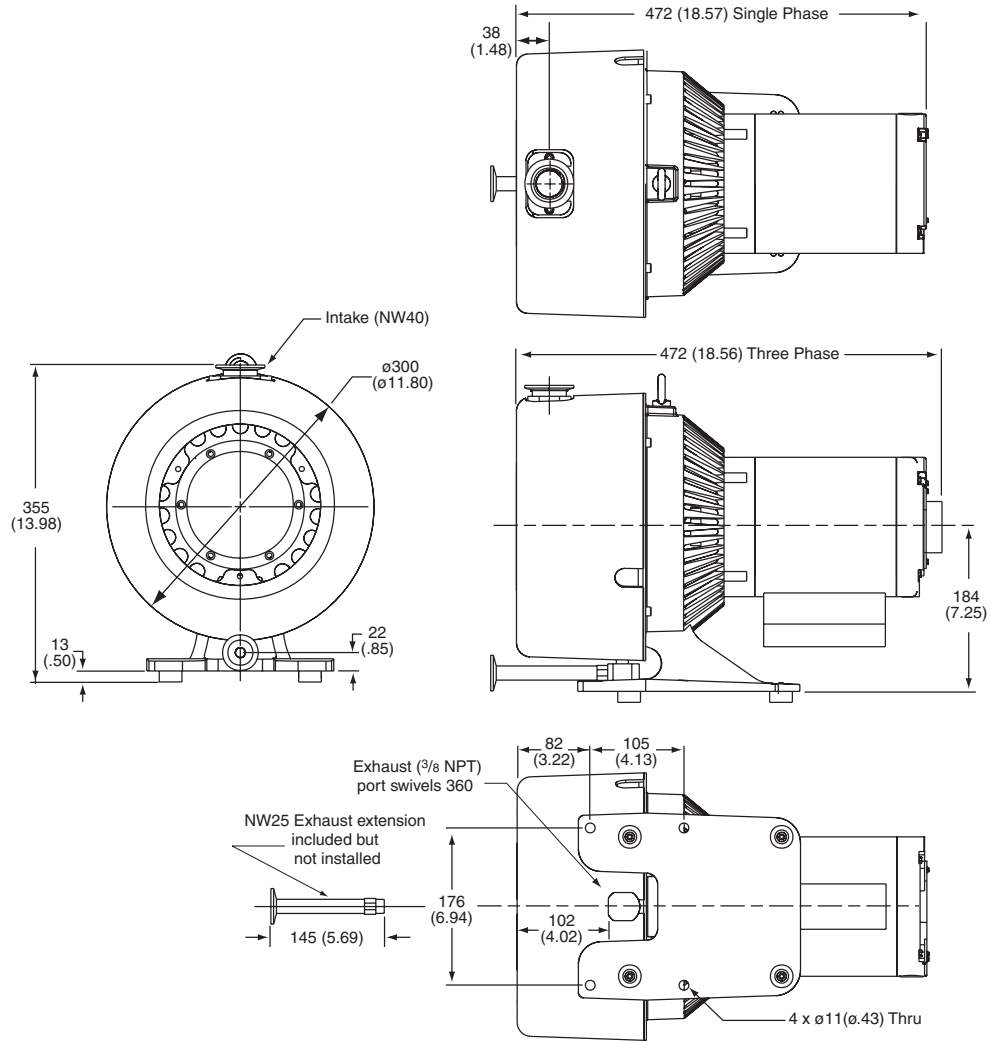

Figure 1 Interface Drawing with Dimensions

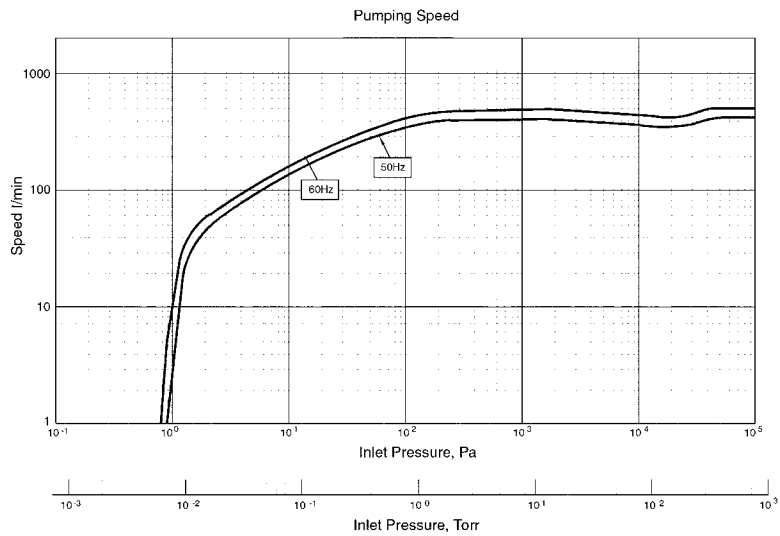
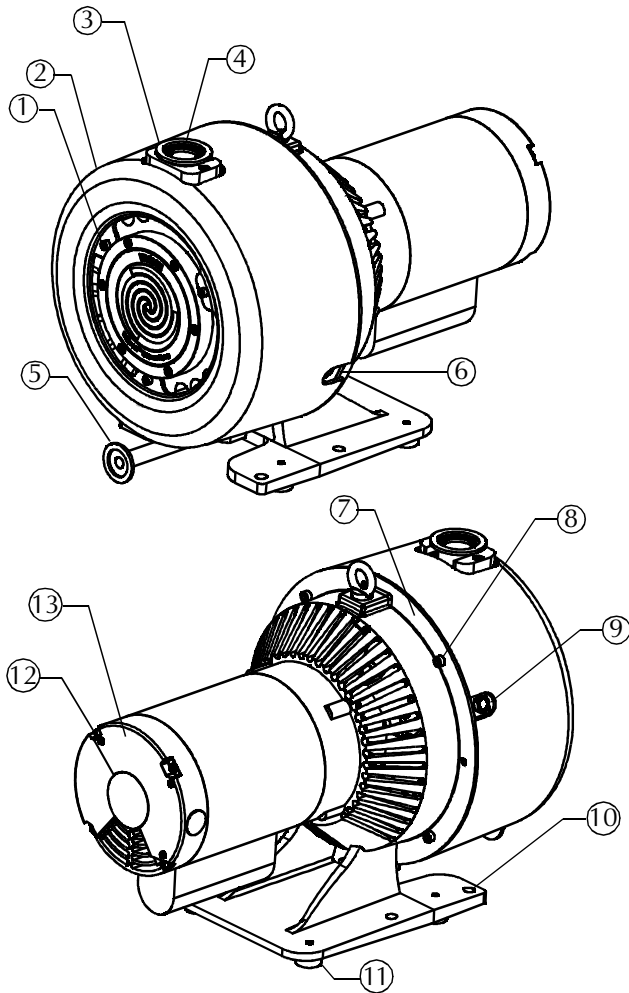

Figure 2 Pumping Speed Curves

TriScroll 600 Series Vacuum Pump



1. Cowling Screws; M5 (3)
2. Cowling
3. Inlet (NW40)
4. Inlet Screen
5. NW25 Exhaust Adapter
6. Bearing Purge Port (1/4" National Pipe Thread)
7. Pump Frame
8. Frame Screws; M6 (4)
9. Gas Ballast Port (1/4" National Pipe Thread)
10. Mounting Holes; 11 mm diameter thru (8)
11. Rubber Feet (4)
12. Motor Cover Screws (3)
13. Motor Electrical Cover

**Figure 3 TriScroll 600 Series Vacuum Pump
(Single Phase Pump Shown)**

Electrical Connections

Wire the motor and electrical interlocks (if applicable) in accordance with local electrical codes and the relevant electrical component manufacturer's instructions. Table 18 lists the full load motor currents at various voltages.

Table 18 Full Load Motor Currents, Amperes

1 phase motor	100 V	115 V	200 V	230 V		
50 Hz	14	13.6	7.0	6.8		
60 Hz	15.2	12.6	7.6	6.3		
3 phase motor	200 V	230 V	380 V	415 V	460 V	
50 Hz	4.4	4.4	2.2	2.2	-	
60 Hz	4.4	4.4	-	-	2.2	

Single Phase Motor Connection

The pump can be configured for low voltage, 100 VAC to 115 VAC, or for high voltage, 200 VAC to 230 VAC. Low voltage exists between connection points "4" and "Line 2" whether the pump motor is configured for low or high voltage. Figure 4 shows the electrical connections for a single phase motor.

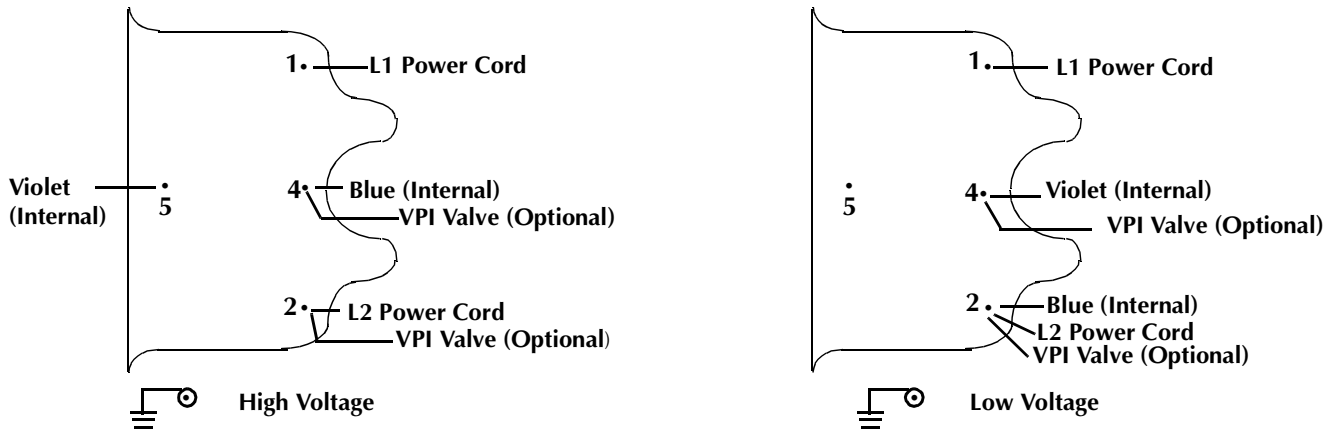

Figure 4 Single Phase Motor Electrical Connections

1. Verify the electrical supply voltage.
2. Remove the three screws (item 12 in Figure 3 on page 35) that are holding the motor electrical cover (item 13 in Figure 3).
3. Refer to Figure 4 to connect the motor to match your supply voltage.

Two options are available to strain relieve the electrical supply cable.

- The cable can be mechanically held under the electrical cover in the groove provided. The groove is sized for 14 gage cable.
- A 1/2–14 NPSM hole is also provided next to the motor cover.

4. Wire L1 and L2 per Figure 4 using right angle flag connectors or ring connectors. Ensure that no exposed wiring is close to the electrical cover or to other terminals on the board.
5. Secure the ground wire under the ground screw using a ring connector.
6. Replace the motor electrical cover and secure it with the three (3) screws removed in step 2.

TriScroll 600 Series Vacuum Pump

Three Phase Motor Connection

The pump can be configured for low voltage, 200 VAC to 230 VAC, or for high voltage, 380 VAC to 415 VAC and 460 VAC. As supplied from the factory, the pump is configured for low voltage. Figure 5 shows the electrical connections for a three phase motor.

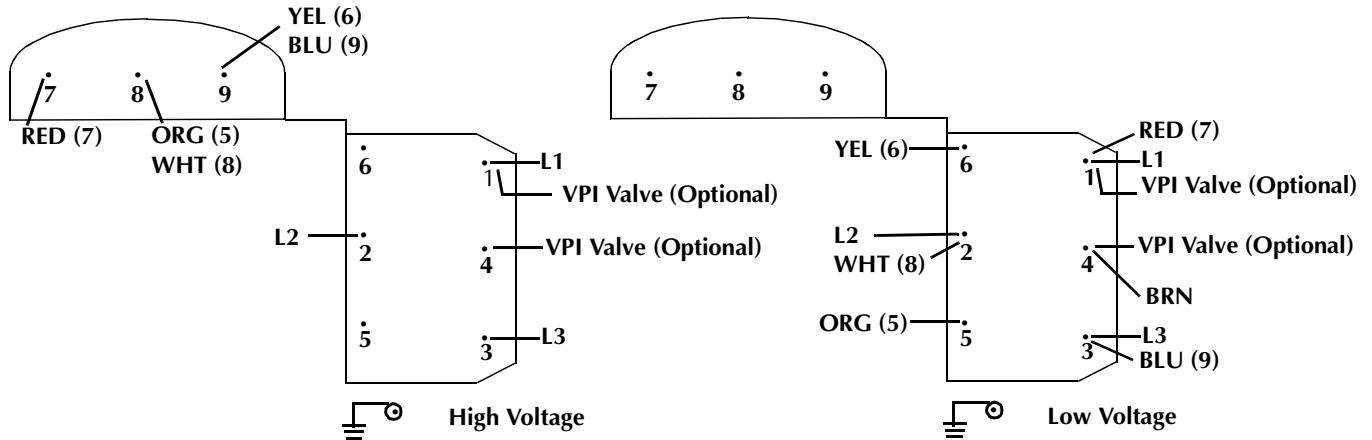

Figure 5 Three Phase Motor Electrical Connections

1. Verify the electrical supply voltage.
2. Remove the three screws (item 12 in Figure 3 on page 35) that are holding the motor electrical cover (item 13 in Figure 3).
3. Refer to Figure 5 to connect the motor to match your supply voltage.

Two options are available to strain relieve the electrical supply cable.

- ❑ The cable can be mechanically held under the electrical cover in the groove provided. The groove is sized for 14 gage cable.
- ❑ A 1/2–14 NPSM hole is also provided next to the motor cover.

4. L1, L2, and L3 are the power cord leads. Wire L1, L2 and L3 per Figure 5 using right angle flag connectors or ring connectors. Ensure that no exposed wiring is close to the electrical cover or to other terminals on the board.
5. Secure the ground wire under the ground screw using a ring connector.
6. Install the motor electrical cover and secure it with the three (3) screws removed in step 2.
7. Momentarily switch on the pump to verify proper rotation. With the inlet uncovered, a strong air flow should come out of the pump exhaust. If there is no flow out the exhaust, reverse any two of the leads (L1, L2 or L3).
8. Repeat the test to verify correct rotation.

Mechanical Connections

Pump Location

Locate the pump on a firm, level surface. Mounting holes provided in the frame can be used to provide permanent attachment. The rubber mounts on the frame can be removed if desired.

Rotation of the Pump Inlet with Respect to the Motor Frame

The standard pump configuration is with the inlet fitting positioned at the top of the pump as shown in Figure 1 on page 34. The pump inlet has two alternate positions:

- ❑ 90 degrees clockwise
- ❑ 90 degrees counterclockwise

To rotate the inlet:

1. Remove three (3) M5 screws (item 1 on Figure 3 on page 35) that secure the cowling (item 2 on Figure 3) to the scroll module. Remove the cowling.
2. Tilt the pump back so that the rear end of the motor touches the floor.
3. Remove the four (4) M6 screws (item 8 on Figure 3) holding the frame (item 7 on Figure 3) and scroll module together.
4. Axially separate the frame and scroll module.
5. Rotate the module 90 degrees in either direction and realign the two (2) locating pins on the scroll module with the mating frame holes. Ensure that the rubber spider is still on the motor coupling and that the coupling teeth are properly aligned.
6. Rejoin the scroll module with the frame and install and tighten the four (4) M6 screws removed in step 3.
7. Reinstall the cowling using the three (3) M5 screws removed in step 1.

Pump Inlet

Use NW40, or larger, clean vacuum hardware with as short a length as practical between the pump and the vacuum chamber.

Use a bellows to provide both vibration isolation and strain relief between the pump and the vacuum chamber.

Pump Exhaust

A female 1/4" National Pipe Thread exhaust fitting is located underneath the scroll module. This fitting swivels 360 degrees. Additionally, an NW25 male adapter with 3/8" National Pipe Thread is provided.

To avoid overheating the pump, do not restrict the exhaust flow with long lengths of small diameter tubing. Use as short as practical lengths of NW25 diameter, or larger, hardware.

Optional Isolation Valve

Scroll pumps return to atmospheric pressure quickly when shut off, thus the installation of a fast acting, automatic, normally closed isolation valve is strongly recommended to prevent pump debris from being transported back into the vacuum chamber when the pump is turned off.

- ❑ The opening of this valve should occur simultaneously with or after pump startup.
- ❑ Valve closing should occur before, simultaneously with, but no later than 250 ms after pump shut off.

Use an NW40 valve or larger and mount it as close as possible to the pump inlet. Mounting to the pump inlet is ideal. (See Figure 6).

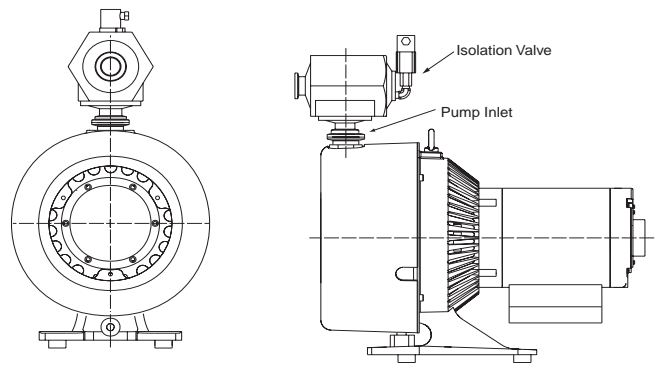

Figure 6 Isolation Valve Location

Vacuum Technologies offers a variety of manual, electromagnetic and electropneumatic controlled vacuum valves for vacuum applications. The Vacuum Technologies Vacuum Pump Isolation (VPI) Valve is highly recommended for vacuum pump isolation applications. The VPI valve application and installation information for use with TriScroll vacuum pumps has been included below.

Vacuum Technologies also sells the TriScroll 600 pump with the VPI valve preinstalled. The part number is PTS06001UVPI.

Overview

The status of the VPI Valve is controlled by the TriScroll motor internal thermal switch and its electrical supply. The VPI Valve opens when the pump is running and closes when it is stopped. It will also close when the TriScroll motor thermal overload protection switch shuts down the pump.

CAUTION



To prevent damage to the VPI Valve, it must be installed by a qualified electrician and only as specified below.

TriScroll 600 Series Vacuum Pump

Wiring

Using the data in Table 19, verify that the VPI Valve chosen is compatible with the TriScroll supply voltage and frequency. Then, locate the proper wiring diagram to use (Figure 4 on page 36 or Figure 5 on page 37).

1. Remove the three screws (item 12 in Figure 3 on page 35) that are holding the motor electrical cover (item 13 in Figure 3).
2. Connect the VPI Valve solenoid wire leads to the pump motor as shown in Figure 4 or Figure 5.
3. Replace the motor electrical cover and secure it using the three screws removed in step 1. Verify that the valve is properly grounded before applying electrical power.

Table 19 VPI Valve Installation Data

Motor	TriScroll Vacuum Pump Operating Voltage	VPI Valve Part # NW25	VPI Valve Part # NW40	Solenoid Operating Voltage Range	Use the following Wiring Diagram
1 Phase	100-120 V 50/60 Hz	VPI251205060	VPI401205060	90-132 V	Figure 4 low voltage
1 Phase	200-230 V 50/60 Hz	VPI251205060	VPI401205060	90-132 V*	Figure 4 high voltage
3 Phase	200 V 50/60 Hz	VPI251205060	VPI401205060	90-132 V*	Figure 5 low voltage
3 Phase	230 V 50/60 Hz	VPI251335060	VPI401335060	120-146 V*	Figure 5 low voltage
3 Phase	380 V 50/60 Hz	VPI252205060	VPI402205060	180-264 V*	Figure 5 high voltage
3 Phase	415 V 50/60 Hz	VPI252205060	VPI402205060	180-264 V*	Figure 5 high voltage
3 Phase	460 V 50/60 Hz	VPI252665060	VPI402665060	239-293 V*	Figure 5 high voltage

* Solenoid operating voltages are lower than the TriScroll vacuum pump operating voltages in order to utilize the TriScroll motor's internal thermal switch to actuate the VPI Valve.

Gas Ballast

The pump incorporates an automatic gas ballast to prevent water and other condensates from accumulating within the pump. The standard configuration is a sintered filter installed in the 1/4" National Pipe Thread gas ballast port (item 9 on Figure 3 on page 35). This allows enough atmospheric air to enter the pump in order to purge condensates while not affecting pump ultimate pressure or pumping speed.

For applications where the ingress of atmospheric air is undesirable, dry nitrogen at a flow rate of ≈ 5 lpm can be bled into the gas ballast port. See "Purge Kit" below. Blocking of the gas ballast port is not recommended.

Bearing Purge

A 1/4" National Pipe Thread bearing purge port (item 6 on Figure 3 on page 35) protects the main crankshaft bearings in applications where large amounts of water are being pumped. In the standard configuration, this port is sealed.

To enable the bearing purge, dry nitrogen at a flow rate of ≈ 5 lpm can be bled into the bearing purge port. This gas supply should be maintained at 2 psig or less and must be kept below 5 psig. See "Purge Kit" below.

CAUTION



The bearing purge port has been disabled on the TriScroll 600 model S4800309. Use of this port could cause internal damage to the pump.

Purge Kit

A purge kit (Vacuum Technologies part number PTSPURGEKIT) is available to properly purge either the bearing purge or the gas ballast. This kit contains a flowmeter and all necessary valving and tubing.

Troubleshooting

Table 20 contains a list of possible problems, their probable causes, and corrective actions.

Table 20 Troubleshooting Chart

Problem	Probable Cause	Corrective Action
Pump won't start	Circuit breaker open	Close breaker. Identify cause of overload.
	Motor thermal protector open	Allow motor to cool. Identify cause of overload.
	Electrical short under the motor electrical cover	Inspect and repair.
	Wiring loose or cut	Repair or replace.
	Excessive voltage drop	Check size and length of power supply cable.
	Defective motor	Inspect. Contact Vacuum Technologies.
Poor ultimate pressure	System leak	Locate and repair leak.
	Water in pump	Flush pump with air or dry nitrogen.
	Gas ballast plugged	Replace breather vent. Contact Vacuum Technologies.
	Solvent in pump	Flush pump with air or dry nitrogen. Install trap or filter.
	Seals worn out	Replace tip seals. (Table 21 and Table 22 on page 41 list maintenance kits and service options.)
	Poor conductance to pump	Replumb with shorter and/or larger diameter tubing.
Pump makes hammering noise	Pump overheated	Check ambient temperature. Check ventilation to pump.
	Debris in pump	Check inlet screen. Flush pump. Disassemble pump and inspect. (Table 21 and Table 22 on page 41 list maintenance kits and service options.)

Maintenance

General Information

Vacuum Technologies TriScroll 600 series pumps are designed to provide years of trouble-free service if maintenance procedures and intervals are observed. Bearing grease replenishment and tip seal replacement is recommended when pump base pressure has risen to an unacceptably high level for your application. Bearings, rotary seals and o-rings should also be replaced if the pump exhibits humming or grinding noises from the bearings. Main bearing life may be shortened if your application requires the pumping of high quantities of water vapor. Use of the bearing purge kit (PTSPURGEKIT) mentioned earlier will keep this water from impacting bearing life.

Maintenance should be performed in accordance with procedures, tooling and materials specified in the manuals listed below.

Related TriScroll Manuals

Other manuals related to tip seal replacement, pump module replacement, and major maintenance of the TriScroll 600 series pumps are listed in Table 21.

Table 21 Other Related Manuals

Title	Applicable TriScroll Model	Part Number
Tip Seal Replacement Manual	All TriScroll 600 Series models	699904310
Pump Module Replacement Manual	All TriScroll 600 Series models	699904305
Major Maintenance Manual	All TriScroll 600 Series models	699904300

Maintenance and Tooling Kits

Material and tooling required to perform maintenance on TriScroll pumps is provided in kit form. A description of each kit and ordering information is provided in Table 22.

Table 22 Maintenance and Tooling Kits

Description	Contents	Applicable TriScroll Model	Part Number
Major Maintenance Kit	All bearings, bearing seals, bearing lubricant, O-rings, and tip seals required to rebuild TriScroll 600 series pumps.	All TriScroll 600 Series models	PTSS0600MK
Maintenance Tool Kit	All fixtures and tools required to perform any maintenance on TriScroll 600 Series pumps.	All TriScroll 600 Series models	PTSS0600TK
Replacement Tip Seal Set	Replacement tip seals and static O-rings for TriScroll 600 Series pumps. <i>NOTE:</i> The Maintenance Tool Kit is also required for tip seal replacement.	All TriScroll 600 Series models	PTSS0600TS

TriScroll 600 Series Vacuum Pump

Factory Service Options

Table 23 lists the factory-rebuild service and advance exchange of complete TriScroll 600 series pumps, as well as factory service options that Vacuum Technologies offers.

Table 23 Factory Service Options

Factory Service Options	Part Number
Advance Exchange TriScroll 600 Single Phase (US cord)	EXPPTS06001
Advance Exchange TriScroll 600 Three Phase	EXPPTS06003
Advance Exchange TriScroll 600 Single Phase (EU cord)	EXPTS06001UNIVEU
Advance Exchange TriScroll 600 Single Phase (UK cord)	EXPTS06001UNIVUK
Advance Exchange TriScroll 610 Single Phase	EXPPTS06101
Advance Exchange TriScroll 610 Three Phase	EXPPTS06103
Advance Exchange TriScroll 600 Pump Module Only	EXPTS0600SC
Advance Exchange TriScroll 610 Pump Module Only	EXPTS0610SC
Service/Rebuild TriScroll 600 Pump (Single or Three Phase)	PTS0600KMA
Service/Rebuild TriScroll 610 Pump (Single or Three Phase)	PTS0610KMA
Service/Rebuild TriScroll 600 Pump Module Only	PTS0600SCRP
Service/Rebuild TriScroll 610 Pump Module Only	PTS0610SCRP

Accessories

The accessories listed in Table 24 are available for use with the TriScroll 600 series pump. Contact your local Vacuum Technologies office to place an order. A list of offices is included on the rear cover of this manual.

Table 24 Accessories

Purge Kit	PTSPURGEKIT
Three Phase Cable Kit	S4789001
Exhaust Extension	S4807001
Exhaust Filter Kit	PTS600EXFIL

Contacting Vacuum Technologies

In the United States, you can contact Vacuum Technologies Customer Service at 1-800-8VARIAN. See the back cover of this manual for a listing of our sales and service offices.

Request for Return Health and Safety Certification



1. Return authorization numbers (RA#) **will not** be issued for any product until this Certificate is completed and returned to a Varian, Inc. Customer Service Representative.
2. Pack goods appropriately and drain all oil from rotary vane and diffusion pumps (for exchanges please use the packing material from the replacement unit), making sure shipment documentation and package label clearly shows assigned Return Authorization Number (RA#) VVT cannot accept any return without such reference.
3. Return product(s) to the nearest location:

4. If a product is received at Varian, Inc. in a contaminated condition, **the customer is held responsible** for all costs incurred to ensure the safe handling of the product, and **is liable** for any harm or injury to Varian, Inc. employees occurring as a result of exposure to toxic or hazardous materials present in the product.

CUSTOMER INFORMATION			
Company name:			
Contact person: Name:	Tel:.....		
Fax:	E-mail:		
Ship method:	Shipping Collect #:	P.O.#:	
Europe only: VAT Reg Number:	USA only: <input type="checkbox"/> Taxable <input type="checkbox"/> Non-taxable		
Customer ship to:	Customer bill to:		
.....		
.....		

PRODUCT IDENTIFICATION

Product Description	Varian, Inc. Part Number	Varian, Inc. Serial Number

TYPE OF RETURN (check appropriate box)

<input type="checkbox"/> Paid Exchange	<input type="checkbox"/> Paid Repair	<input type="checkbox"/> Warranty Exchange	<input type="checkbox"/> Warranty Repair	<input type="checkbox"/> Loaner Return
<input type="checkbox"/> Credit	<input type="checkbox"/> Shipping Error	<input type="checkbox"/> Evaluation Return	<input type="checkbox"/> Calibration	<input type="checkbox"/> Other

HEALTH and SAFETY CERTIFICATION

VACUUM TECHNOLOGIES CANNOT ACCEPT ANY BIOLOGICAL HAZARDS, RADIOACTIVE MATERIAL, ORGANIC METALS, OR MERCURY AT ITS FACILITY. CHECK ONE OF THE FOLLOWING:		
<input type="checkbox"/> I confirm that the above product(s) has (have) NOT pumped or been exposed to any toxic or dangerous materials in a quantity harmful for human contact.		
<input type="checkbox"/> I declare that the above product(s) has (have) pumped or been exposed to the following toxic or dangerous materials in a quantity harmful for human contact (<u>Must be filled in</u>):		
Print Name	Signature	Date

PLEASE FILL IN THE FAILURE REPORT SECTION ON THE NEXT PAGE

Do not write below this line

Notification (RA) #: Customer ID #: Equipment #:

Request for Return Health and Safety Certification



FAILURE REPORT

(Please describe in detail the nature of the malfunction to assist us in performing failure analysis):

TURBO PUMPS AND TURBOCONTROLLERS

Claimed Defect	Position	Parameters
<input type="checkbox"/> Does not start <input type="checkbox"/> Does not spin freely <input type="checkbox"/> Does not reach full speed <input type="checkbox"/> Mechanical Contact <input type="checkbox"/> Cooling defective <input type="checkbox"/> Noise <input type="checkbox"/> Vibrations <input type="checkbox"/> Leak <input type="checkbox"/> Overtemperature <input type="checkbox"/> Clogging	<input type="checkbox"/> Vertical <input type="checkbox"/> Horizontal <input type="checkbox"/> Upside-down <input type="checkbox"/> Other	Power: Rotational Speed: Current: Inlet Pressure: Temp 1: Foreline Pressure: Temp 2: Purge flow: Operation Time:
Describe Failure:		
Turbocontroller Error Message:		

ION PUMPS/CONTROLLERS

<input type="checkbox"/> Bad feedthrough <input type="checkbox"/> Vacuum leak <input type="checkbox"/> Error code on display <input type="checkbox"/> Poor vacuum <input type="checkbox"/> High voltage problem <input type="checkbox"/> Other
Describe failure:
Customer application:

VALVES/COMPONENTS

<input type="checkbox"/> Main seal leak <input type="checkbox"/> Solenoid failure <input type="checkbox"/> Damaged sealing area <input type="checkbox"/> Bellows leak <input type="checkbox"/> Damaged flange <input type="checkbox"/> Other
Describe failure:
Customer application:

LEAK DETECTORS

<input type="checkbox"/> Cannot calibrate <input type="checkbox"/> Vacuum system unstable <input type="checkbox"/> Failed to start <input type="checkbox"/> No zero/high background <input type="checkbox"/> Cannot reach test mode <input type="checkbox"/> Other
Describe failure:
Customer application:

INSTRUMENTS

<input type="checkbox"/> Gauge tube not working <input type="checkbox"/> Communication failure <input type="checkbox"/> Display problem <input type="checkbox"/> Degas not working <input type="checkbox"/> Error code on display <input type="checkbox"/>
Describe failure:
Customer application:

ALL OTHER VARIAN, INC.

<input type="checkbox"/> Pump doesn't start <input type="checkbox"/> Doesn't reach vacuum <input type="checkbox"/> Pump seized <input type="checkbox"/> Noisy pump (describe) <input type="checkbox"/> Overtemperature <input type="checkbox"/> Other
Describe failure:
Customer application:

DIFFUSION PUMPS

<input type="checkbox"/> Heater failure <input type="checkbox"/> Doesn't reach vacuum <input type="checkbox"/> Vacuum leak <input type="checkbox"/> Electrical problem <input type="checkbox"/> Cooling coil damage <input type="checkbox"/> Other
Describe failure:
Customer application: