

Chemtech Scientific provides access to this content as a courtesy.
We do not own the content contained in this document.
All rights and credit go directly to its rightful owners.
www.chemtechsci.com
Call us at: 484-424-9415



IDP-3 Dry Scroll Vacuum Pump

vacuum technologies

INSTRUCTION MANUAL

Manual No. 699904350
Revision B
July 2007

IDP-3

Dry Scroll Vacuum Pump

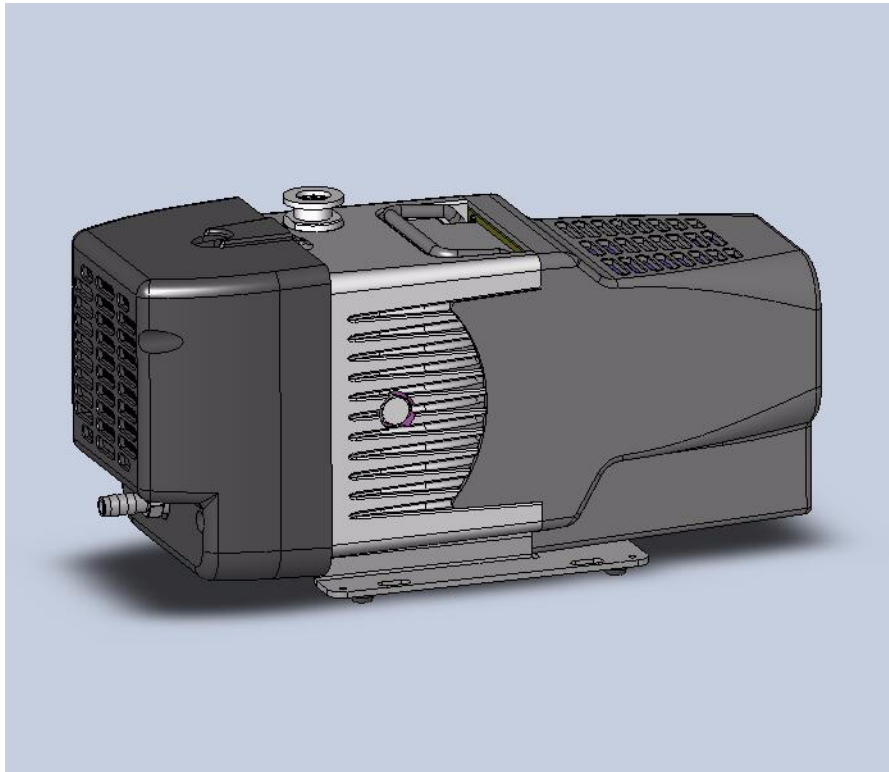

Warranty

Products manufactured by Seller are warranted against defects in materials and workmanship for twelve (12) months from date of shipment thereof to Customer, and Seller's liability under valid warranty claims is limited, at the option of Seller, to repair, to replace, or refund of an equitable portion of the purchase price of the Product. Items expendable in normal use are not covered by this warranty. All warranty replacement or repair of parts shall be limited to equipment malfunctions which, in the sole opinion of Seller, are due or traceable to defects in original materials or workmanship. All obligations of Seller under this warranty shall cease in the event of abuse, accident, alteration, misuse, or neglect of the equipment. In-warranty repaired or replaced parts are warranted only for the remaining unexpired portion of the original warranty period applicable to the repaired or replaced parts. After expiration of the applicable warranty period, Customer shall be charged at the then current prices for parts, labor, and transportation.

Reasonable care must be used to avoid hazards. Seller expressly disclaims responsibility for loss or damage caused by use of its Products other than in accordance with proper operating procedures.

Except as stated herein, Seller makes no warranty, expressed or implied (either in fact or by operation of law), statutory or otherwise; and, except as stated herein, Seller shall have no liability under any warranty, expressed or implied (either in fact or by operation of law), statutory or otherwise. Statements made by any person, including representatives of Seller, which are inconsistent or in conflict with the terms of this warranty shall not be binding upon Seller unless reduced to writing and approved by an officer of Seller.

Warranty Replacement and Adjustment

All claims under warranty must be made promptly after occurrence of circumstances giving rise thereto, and must be received within the applicable warranty period by Seller or its authorized representative. Such claims should include the Product serial number, the date of shipment, and a full description of the circumstances giving rise to the claim. Before any Products are returned for repair and/or adjustment, written authorization from Seller or its authorized representative for the return and instructions as to how and where these Products should be returned must be obtained. Any Product returned to Seller for examination shall be prepaid via the means of transportation indicated as acceptable by Seller. Seller reserves the right to reject any warranty claim not promptly reported and any warranty claim on any item that has been altered or has been returned by non-acceptable means of transportation. When any Product is returned for examination and inspection, or for any other reason, Customer shall be responsible for all damage resulting from improper packing or handling, and for loss in transit, notwithstanding any defect or non-conformity in the Product. In all cases, Seller has the sole responsibility for determining the cause and nature of failure, and Seller's determination with regard thereto shall be final.

If it is found that Seller's Product has been returned without cause and is still serviceable, Customer will be notified and the Product returned at the Customer's expense; in addition, a charge for testing and examination may be made on Products so returned.

3/1/00

IDP-3 Dry Scroll Vacuum Pump

This page intentionally left blank.

Contents

Warranty	iii
Warranty Replacement and Adjustment	iii
Instructions for Use	1
General Information	1
Storage	1
Installation	2
Use	2
Maintenance	2
Technical Information	3
Unpacking and Inspection	5
Installation	6
Safety	6
Startup	6
Electrical Connections	6
Run Currents	8
Start Current	8
Mechanical Connections	9
Operation	9
Cleaning the Pump	9
Startup Procedure	9
Shutdown Procedure	9
Troubleshooting	10
Maintenance	11
Kits and Service Options	11
Cleaning	11
Tip Seal Replacement	11
Pump Module Replacement	12

Request for Return Health and Safety Certification

List of Figures

Figure	Caption	Page
1	Interface Drawing with Dimensions	4
2	Outline Drawing and Principal Items	5
3	Grounding Plug and Outlet	7
4	ON/OFF Power Switch	9
5	Exploded View of Pump Body	12
6	Exploded View of Pump Body	12

List of Tables

Table	Title	Page
1	Specifications	3
2	IDP-3 Power Cord Selection	6
3	IDP-3 Typical Run Currents (A)	8
4	Typical IDP-3 Maximum Starting Current and Duration	8
5	Troubleshooting Chart	10
6	Tip Seal Replacement Kit	11

IDP-3 Dry Scroll Vacuum Pump

This page intentionally left blank.

Declaration of Conformity
Konformitätserklärung
Déclaration de Conformité
Declaración de Conformidad
Verklaring de Overeenstemming
Dichiarazione di Conformità
一致性声明

We
Wir
Nous
Nosotros
Wij
Noi
我们
私たち
우리는

declare under our sole responsibility that the product,
erklären, in alleiniger Verantwortung, daß dieses Produkt,
déclarons sous notre seule responsabilité que le produit,
declaramos, bajo nuestra sola responsabilidad, que el producto,
verklaren onder onze verantwoordelijkheid, dat het product,
dichiariamo sotto nostra unica responsabilità, che il prodotto,
基于独立承担责任的原则, 特声明
は、当社単独の責任の下、この宣言が該当する製品
당사의 책임하에

IDP-3 Dry Scroll Vacuum Pump

to which this declaration relates is in conformity with the following standard(s) or other normative documents.
auf das sich diese Erklärung bezieht, mit der/den flogenden Norm(en) oder Richtlinie(n) übereinstimmt.
auquel se réfère cette déclaration est conforme à la (aux) norme(s) ou au(x) document(s) normatif(s).
al que se refiere esta declaración es conforme a la(s) norma(s) u otro(s) documento(s) normativo(s).
waamaar deze verklaring verwijst, aan de volende norm(en) of richtlijn(en) beantwoordt.
a cui se riferisce questa dichiarazione è conforme alla/e sequente/l norma/o documento/l normativo/i.
符合以下标准或其它标准文档要求。
が、以下の規格またはその他の基準書類に適合することを宣言します。
이 선언과 관련한 제품이 다음의 표준과 기타 표준 문서를 준수한다는 것을 선언합니다.

to which this declaration relates is in conformity with the following standards:

- 89/392/EEC Safety Requirements
- EN 60204-1 Safety of Machinery
- EN 61010-1 Safety Requirements
- EN 61000-6-2 EMC Immunity
- EN 61000-6-4 EMC Emissions
- EN 61326 EMC Immunity and Emissions

Instructions for Use

General Information

This equipment is designed for use by professionals. The user should read this instruction manual and any other additional information supplied by Varian before operating the equipment. Varian will not be held responsible for any events that occur due to non-compliance with these instructions, improper use by untrained persons, non-authorized interference with the equipment, or any action contrary to that provided for by specific national standards.

The IDP-3 is a hermetic, dry scroll vacuum pump. This pump is suitable for pumping air or inert gases. The pump is not intended to pump corrosive, explosive, or particulate-forming gases.

The following paragraphs contain all the information necessary to guarantee the safety of the operator when using the equipment. Detailed information is supplied in "Technical Information" on page 3.

This manual uses the following standard safety protocol:

WARNING



The warning messages are for attracting the attention of the operator to a particular procedure or practice which, if not followed correctly, could lead to serious injury.

CAUTION



The caution messages are displayed before procedures, which if not followed, could cause damage to the equipment.

NOTE



The notes contain important information taken from the text.

Storage

When transporting and storing the pump, the following environmental requirements should not be exceeded:

Temperature: -20 °C to +60 °C (-4 °F to 140 °F)

Relative humidity: 0 to 95% (non-condensing)

Preparation for Installation

The pump is supplied in a special protective packing. If this shows signs of damage, which may have occurred during transport, contact your local sales office.

Total weight of the packing, IDP-3 pump included, is approximately 10.5 kg (23 lbs).

WARNING



When unpacking the pump, be sure not to drop it and avoid any kind of sudden impact or shock vibration to it.

NOTE



Normal exposure to the environment cannot damage the pump. Nevertheless, it is advisable to keep the pump inlet closed until the pump is installed in the system.

IDP-3 Dry Scroll Vacuum Pump

Installation

Do not install or use the pump in an environment exposed to atmospheric agents (rain, snow, ice), dust, aggressive gases, or in explosive environments or those with a high fire risk.

If placing the IDP-3 pump inside an enclosure, provide ample room to supply ambient air to both the front and rear air intakes of the pump.

During operation, the following environmental conditions must be respected:

Temperature: +5 °C to +40 °C (41 °F to 104 °F)

Relative humidity: 0 to 95% (non-condensing)

There are three versions of the IDP-3:

- 100 VAC, 50/60 Hz
- 115 VAC, 60 Hz
- 220-230 VAC, 50/60 Hz

CAUTION



Be certain that your electrical mains power voltage corresponds to that indicated on the rear of the pump.

Connect the pump to the power supply using an IEC-320 style power cord of at least 10 A capacity.

CAUTION



Never disturb the two hex head bolts on either side of the pump. Disturbing these bolts will cause loss of performance and/or pump damage.

Use

In order to reach maximum vacuum, the pump must be left running for about an hour with the inlet sealed.

There are no special instructions for starting the pump; it need only be switched on using the On/Off switch.

WARNING



The pump is designed for operation with neutral or noncorrosive fluids. It is absolutely forbidden to use it with potentially explosive or inflammable substances.

There are no special instructions for stopping the pump; it need only be disconnected from the electric power source by the On/Off switch.

Maintenance

Personnel responsible for pump operation and maintenance must be well-trained and aware of the accident prevention rules.

WARNING



- Death may result from contact with high voltages. Always take extreme care and observe the accident prevention regulations in force.*
- When machine is powered up, be careful of moving parts and high voltages.*
- If you have to perform maintenance on the pump after a considerable time in operation, allow it to cool as the temperature of the outer surface may be in excess of 60 °C.*
- Always disconnect your power supply to the pump before beginning maintenance work.*

NOTE



Before returning the pump to the factory for repair, the "Health and Safety" sheet attached to this instruction manual must be completed and sent to the local sales office. A copy of the sheet must be inserted in the pump package before shipping.

If a pump is to be discarded, it must be disposed of in accordance with specific national standards.

Technical Information

Table 1 Specifications

Model	IDP-3 Dry Scroll Single Hermetic Vacuum Pump
Interface dimensions	See Figure 1 on page 4
Peak pumping speed	<input type="checkbox"/> 50 Hz: 50 L/m, 3.0 m ³ /hr (1.8 cfm) <input type="checkbox"/> 60 Hz: 60 L/m, 3.6 m ³ /hr (1.3 cfm)
Media	No corrosive, explosive or particulate forming gases
Ultimate pressure	5.0 x 10 ⁻¹ Torr (6.6 x 10 ⁻¹ mbar)
Maximum inlet pressure	1.0 atmosphere (0 psig)
Maximum outlet pressure	6.5 psig
Inlet connection	NW16
Exhaust connection	Female 1/4" National Pipe Thread (10 mm hose barb provided)
Gas ballast	Female 1/8" National Pipe Thread (adapter provided)
Ambient operating temperature	5 °C to 45 °C (41 °F to 113 °F)
Storage temperature	-20 °C to 60 °C (-4 °F to 140 °F)
Motor rating	0.16 HP (0.12 kW)
Operating voltages	<input type="checkbox"/> 1 phase/ 100 VAC, 50/60 Hz <input type="checkbox"/> 1 phase/ 115 VAC, 60 Hz <input type="checkbox"/> 1 phase/ 220-230 VAC, 50/60 Hz
Run current	See Table 3 on page 8
Motor thermal protection	Automatic thermal protection
Operating speed	60 Hz: 3200 RPM, 50 Hz: 2600 RPM
Cooling system	Air-cooled
Weight	Pump only: 9.5 kg (21 lbs) Shipping weight: 10.5 kg (23 lbs)
Leak rate (with exhaust and gas ballast sealed)	<1 x 10 ⁻⁶ sccs helium
Vibration level at inlet, per ISO 10816-1	≤ 1.5 mm/sec
Noise level, per ISO 11201	≤ 55 dBA
Conformance standards	See Declaration of Conformity

IDP-3 Dry Scroll Vacuum Pump

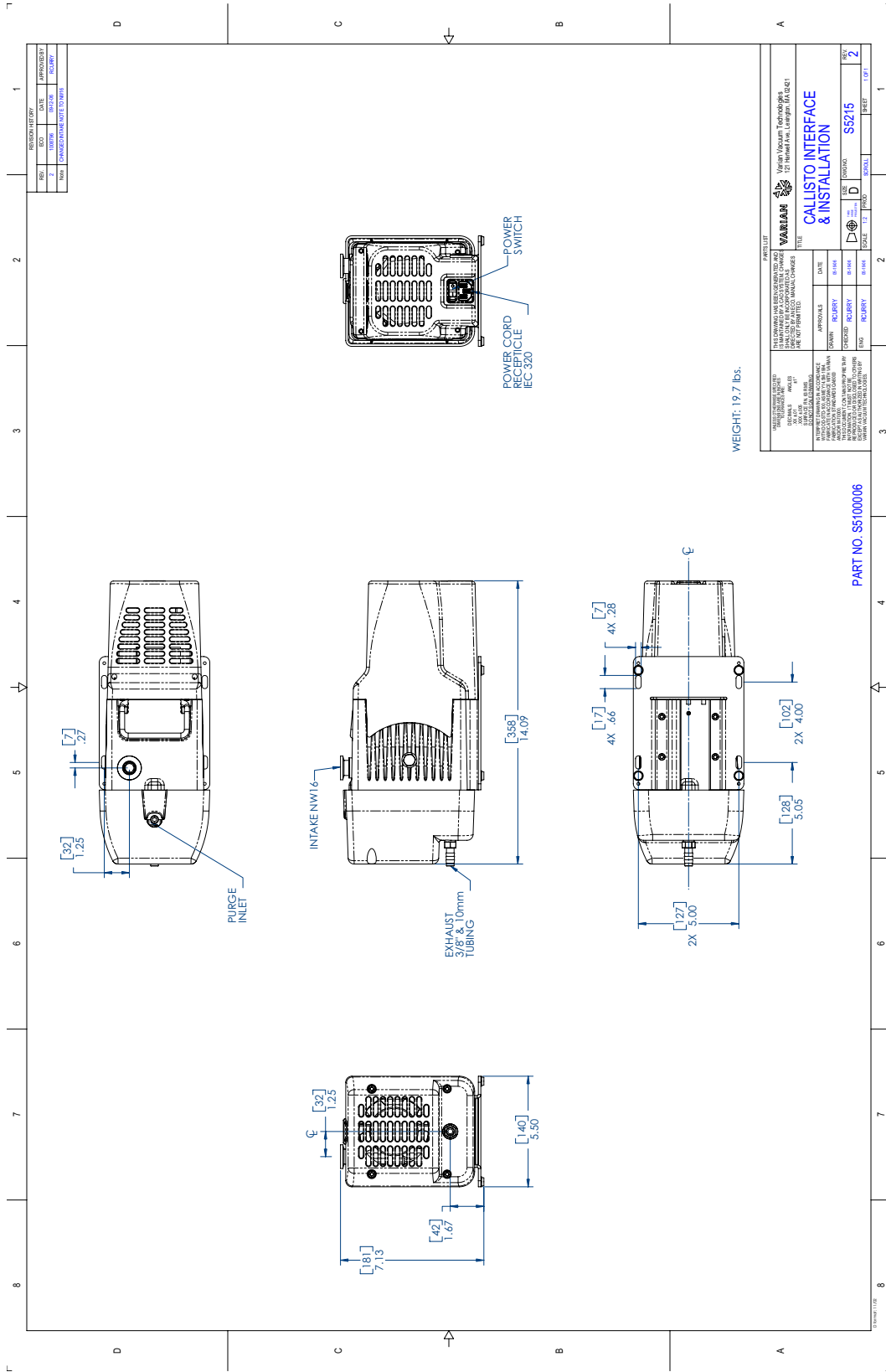
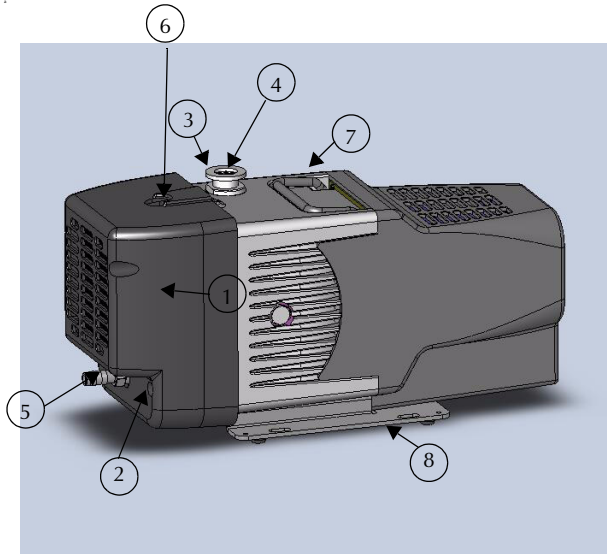
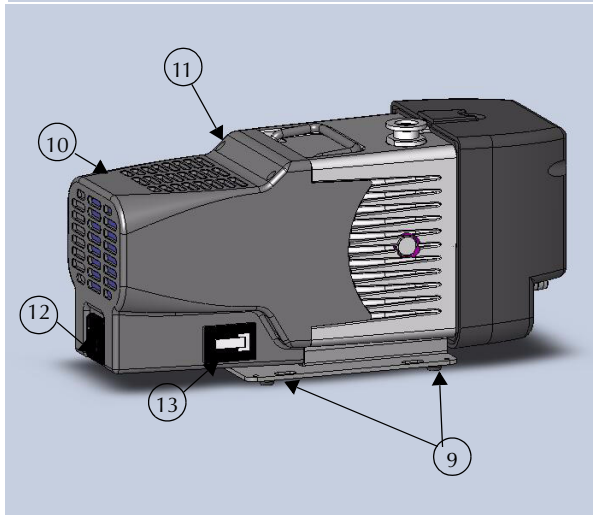

Figure 1 Interface Drawing with Dimensions

IDP-3 Dry Scroll Vacuum Pump



1. Front Cowling Screws; M5 (4)
2. Front Cowling
3. Inlet (NW16)
4. Inlet Screen
5. 10 mm Hose Barb
6. Gas Ballast Port (1/8" NPT adapter provided)
7. Frame
8. Base
9. Mounting Holes; (4) for 1/4" or M6 Hardware
10. Rear Cowling
11. Rear Cowling Screws: M5 (4)
12. On/Off Switch/Power Connection (IEC-320)
13. Hour Meter (optional)



Unpacking and Inspection

1. Orient the shipping container with *This End Up* on top.
2. Open the box and carefully lift the IDP-3 and foam blocks out of the box. Remove the foam blocks.
3. Save the carton and all packing materials.
4. Inspect the pump for damage. If there is shipping damage, contact the freight carrier and your local Varian sales office immediately.

Figure 2 Outline Drawing and Principal Items

IDP-3 Dry Scroll Vacuum Pump

Installation

Safety

Do not remove or modify any safety or insulating equipment from the pump. To do so may create a serious safety hazard and may void the warranty.

WARNING



❑ *This pump is capable of pumping air and inert gases only. It is not designed to pump explosive, flammable, corrosive or particulate forming gases. They can cause bodily injury, explosion, or fire.*

❑ *Install in an area that is not exposed to rain, steam, or excessive humidity. They can cause electric shock, short circuits, and severe bodily injury.*

❑ *Before inspecting or servicing the pump, be sure the electrical supply is disconnected.*

❑ *The gas ballast must be sealed whenever pumping any gas not intended to be vented to the atmosphere.*

CAUTION



Although the pump can pump trace particulates normally found in the atmosphere, it is not designed to process solids, chemicals, powders, solvents, condensates, or other particulates. They can damage the equipment, degrade its performance, or shorten its useful life.

There are three versions of the IDP-3:

- ❑ 100 VAC, 50/60 Hz
- ❑ 115 VAC, 60 Hz
- ❑ 220-230 VAC, 50/60 Hz

CAUTION



Ensure that the pump version conforms to the supply voltage before using.

Startup

1. Check that the inlet screen is installed before beginning operation.

WARNING



Do not insert a finger or any foreign object in the path of the fan; serious personal injury may result or the pump may be damaged.

2. Operate the pump at an ambient temperature of 5 °C to 45 °C (41 °F to 113 °F), otherwise damage to the pump or shortened operating life may result.

CAUTION



Do not block the fan ducts. Blocking these ducts can cause pump overheating. A pump surface temperature in excess of 65 °C (150 °F) is potentially damaging. If such conditions are observed, turn the pump off and allow it to cool. Disassemble, inspect for damage, and repair, if necessary.

Electrical Connections

Power Cord

Several power cord options are available from your Varian dealer. Descriptions of the available power cords and their ordering numbers are given in Table 2.

NOTE



For high voltage operation, the pump must be connected to the power supply using a high voltage IEC-320 type power cord of at least 10 A capacity.

CAUTION



Be certain that your electrical mains power voltage corresponds to that indicated on the rear of the pump.

Table 2 IDP-3 Power Cord Selection

Country	Power Cord Specification	Order
Europe	10 A / 220-230 VAC, 2.5 m	656494220
Denmark	10 A / 220-230 VAC, 2.5 m	656494225
Switzerland	10 A / 230 VAC, 2.5 m	656494235
UK/Ireland	13 A / 230 VAC, 2.5 m	656494250

IDP-3 Dry Scroll Vacuum Pump

Table 2 IDP-3 Power Cord Selection (Continued)

Country	Power Cord Specification	Order
India	10 A / 220-250 VAC, 2.5 m	656494245
Israel	10 A / 230 VAC, 2.5 m	656494230
Japan	12 A / 100 VAC, 2.3 m	656494240
North America	15 A / 125 VAC, 2.0 m	656458203
	10 A / 230 VAC, 2.5 m	656494255

Grounding Instructions

This product should be grounded. In the event of an electrical short circuit, grounding reduces the risk of electric shock by providing an escape wire for the electric current. This pump is equipped with a power cord that has a grounding wire with an appropriate grounding plug. The plug must be inserted into an outlet that is properly installed and grounded in accordance with all local codes and ordinances.

DANGER



Improper installation of the grounding plug can result in a risk of electrical shock.

For United States and Canadian installations:

- When this product is configured for use on a nominal 120 V circuit, it must be used with a grounding plug that looks like the plug illustrated in Figure 3.*
- If repair or replacement of the cord or plug is necessary, connect the grounding wire to the grounding terminal only.*
- The grounding wire is insulated and its outer surface is green. It may or may not have yellow stripes.*
- When this product is configured for use on a nominal 220 V circuit, it must be used with a factory supplied cord and plug that permits connection to the proper electric circuit. See "Electrical Connections" on page 6 for proper rating and type of cord set.*

WARNING



Check with a qualified electrician or serviceman if the grounding instructions are not completely understood, or if you are in doubt as to whether the product is properly grounded.

Do not modify the plug provided; if it does not fit the outlet, have the proper outlet installed by a qualified electrician.

Connect the product only to an outlet that has the same configuration as the plug.

Do not use an adapter with this product.

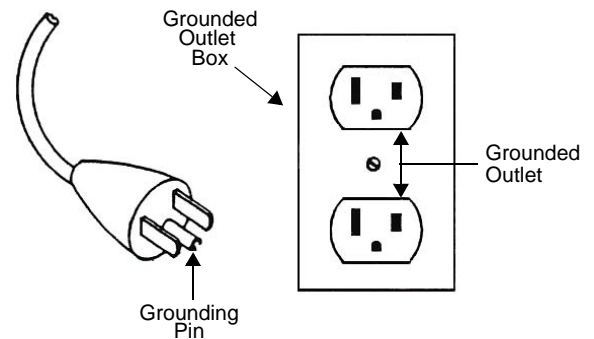

Figure 3 Grounding Plug and Outlet

WARNING



If the product must be reconnected for use on a different type of electric circuit, the connector should be replaced by qualified service personnel.

Extension Cords

If you must use an extension cord with this product:

- For this product, Varian recommends using only extension cords with a minimum of 16-gage wire and a maximum length of 25 feet (7.6 m).
- Use only a 3-wire extension cord that will accept the plug.
- Make sure your extension cord is in good condition.
- Be sure the extension cord is rated high enough to carry the current your product will draw. An undersized cord will cause a drop in line voltage resulting in loss of power and overheating.

IDP-3 Dry Scroll Vacuum Pump

Run Currents

Typical run currents listed in Table 3 are approximately constant from minimum to maximum intake pressure.

Table 3 IDP-3 Typical Run Currents (A)

Frequency	100 V Nominal			115 V Nominal			220 - 230 V Nominal			
	90 V	100 V	110 V	103.5 V	115 V	127 V	198 V	220 V	230 V	253 V
60 Hz	2.3	2.2	2.2	1.8	1.8	1.8	1.1	1.1	1.1	1.1
50 Hz	1.6	1.6	1.8	N/A	N/A	N/A	0.8	0.8	0.8	1.0

Start Current

Table 4 lists the typical IDP-3 maximum starting current and duration.

Table 4 Typical IDP-3 Maximum Starting Current and Duration

Mains Voltage	50 Hz		60 Hz	
	Current (A)	Time (ms)	Current (A)	Time (ms)
100 V	2.8	300	2.8	500
115 V	N/A	N/A	3.3	500
220 V	1.3	300	1.3	500
230 V	1.4	300	1.4	300

IDP-3 Dry Scroll Vacuum Pump

Mechanical Connections

Pump Inlet

Use NW16, or larger, clean vacuum hardware with as short a length as practical between the pump and vacuum chamber.

Insert a bellows between the pump and vacuum chamber to provide both vibration isolation and strain relief.

Pump Exhaust

A female 1/4" National Pipe Thread exhaust fitting is located on the front of the pump. Additionally, a 10 mm (3/8") hose barb fitting is provided. To avoid overheating the pump, do not restrict the exhaust flow with long lengths of small diameter tubing. Use as short as practical lengths of 10 mm ID, or larger, diameter hardware.

Gas Ballast

The pump incorporates an automatic gas ballast to prevent water and other condensates from accumulating within the pump. The standard configuration has a seal screw installed in the 1/4-20 thread in the top of the exhaust manifold (item 6 on Figure 2 on page 5). This configuration can be used for relatively dry applications. When appreciable amounts of water, solvents, etc., are being pumped, remove the seal screw and replace it with the provided adapter and 1/8" NPT sintered filter plug. Do not exceed 25 in-lb of torque when installing the adapter into the manifold.

For applications where the ingress of atmospheric air is undesirable, dry nitrogen at a flow rate of approximately 5 l/min can be provided to the gas ballast. Remove the 1/8" NPT sintered filter plug from the adapter and replace it with an appropriate fitting (supplied by end user).

WARNING



The gas ballast must be sealed whenever pumping any gas not intended to be vented to atmosphere.

Operation

Cleaning the Pump

Unlike conventional oil-sealed pumps, Varian dry scroll pumps do not contain fluid for the cleansing of accumulated dust and debris. Run the pump periodically at atmosphere for a minute or two to flush it out. Until experience is gained on your specific process, flush the pump regularly and adjust this schedule according to your specific conditions.

Startup Procedure

1. Make sure that the pump is configured for the mains voltage to which the pump is connected.

NOTE



The pump ON/OFF switch is a rocker type switch that has symbols in accordance with IEC Publication 417 to represent the ON and OFF positions. Figure 4 shows a switch in the ON position.

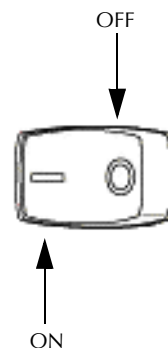

Figure 4 ON/OFF Power Switch

2. Switch the pump ON.

Shutdown Procedure

To shutdown the pump:

- Switch the pump OFF.

IDP-3 Dry Scroll Vacuum Pump

Troubleshooting

Use the Troubleshooting chart in Table 5 to assist in defining a problem, determining a possible cause, and defining action steps to remedy the situation.

Table 5 Troubleshooting Chart

Problem	Possible Causes	Corrective Actions
Will not start	Motor thermal protector open	Allow motor to cool. Identify cause of overload.
	Excessive voltage drop	Check size and length of cable.
	Defective motor	Inspect. Contact Varian .
Poor ultimate pressure	System leak	Locate and repair leak.
	Water in pump	Flush pump with air or dry nitrogen.
	Solvent in pump	Flush pump with air or dry nitrogen. Install trap or filter.
	Seals worn out	Replace tip seals.
	Poor conductance to pump	Replumb with shorter and/or larger diameter tubing.
Hammering noise	Pump overheated	Check ventilation to pump. Check ambient temperature.
	Debris in pump	Check intake screen. Flush pump. Disassemble pump and inspect.
Pump runs intermittently	Motor thermal protector is cycling open and closed.*	Allow the motor to cool. Identify the cause of the overload.

* *The IDP-3 is equipped with an auto-reset thermal motor protector. This protector automatically shuts down the pump when it detects an overload condition, and automatically restarts the pump when the motor has cooled to within an acceptable temperature range.*

IDP-3 Dry Scroll Vacuum Pump

Maintenance

Kits and Service Options

Varian pumps will provide many years of trouble-free service if the maintenance procedures and intervals are observed. Cleaning and tip seal replacement are recommended when pump base pressure has risen to an unacceptably high level for your application. If your pump exhibits humming or grinding noises from the bearings, a major overhaul should be done by Vacuum Technologies or an authorized rebuild center. Advance exchange pumps are available to minimize downtime.

The parts needed for tip seal replacement on the IDP-3 are available in the kit described in Table 6. This kit contains seals and O-rings, and can be obtained from your Varian dealer.

Table 6 Tip Seal Replacement Kit

Part Number	Description	Contents
IDP3TS	Replacement Tip Seal Set	Replacement Tip Seals and O-rings for IDP-3 pumps

Cleaning

Exterior

The exterior surfaces of the IDP-3 may be cleaned with alcohol or mild detergents only.

Interior

Run the pump periodically at atmosphere for a minute or two to flush it out. For more information, see "Cleaning the Pump" on page 9.

Tip Seal Replacement

The parts and tools required to replace tip seals are listed below:

- Tip Seal Replacement Kit P/N IDP3TS
- 4 mm Allen wrench
- Razor blade or side-cutting pliers
- Compressed air (optional)

WARNING



If dangerous gases were being pumped, flush the pump with air or inert gas for at least 10 minutes prior to disassembly.

Figure 5 on page 12 shows the various components involved in a tip seal replacement procedure. Refer to Figure 5 as you follow the procedure.

To remove the worn tip seals:

1. Disconnect the pump from electrical power.
2. Remove (4) M5 socket head bolts (item 1).
3. Remove the front cowling and disconnect the electrical connector and set the cowling aside.
4. Remove (4) M5 bolts (item 4).
5. Remove the outboard housing axially off the frame (item 5).
6. Remove and discard the worn tip seals (item 6) and the main O-ring (item 7).
7. If compressed air is available, blow any remaining seal debris off the scroll parts. If seal debris is attached to the sides, use a razor or Exacto knife to scrape the debris off.

To install the new seals and O-rings:

1. Unpack the tip seals.
Two tip seals are provided in the kit; one fits the orbiting scroll and the other fits the outboard housing scroll.
2. Install the correct tip seal into the groove of the orbiting scroll (item 8) by:
 - a. Facing the white plastic surface upwards and inserting the foam backing into the groove. Start from the center and work outward.
 - b. Cutting the tip seal off about 1/8" (3 mm) from the outer end of the groove.
3. Install the correct tip seal into the groove of the outboard housing scroll (item 4) as in step 3.
4. Place the new main O-ring into the groove in the frame (item 10). Ensure that the groove is clean.
5. Ensure the sealing face of the outboard housing is clean. Carefully replace the outboard housing by lining up the locating pins. Ensure the tip seal has not fallen out of its groove.
6. Reinstall (4) M5 bolts (item 4) and torque the (4) M5 bolts to 5.6 N-m (50 in-lb).
7. Reconnect the electrical connector at the front cowling.
8. Place the front cowling in place and replace the M5 bolts.
9. Reconnect the pump to the electrical power mains.

IDP-3 Dry Scroll Vacuum Pump

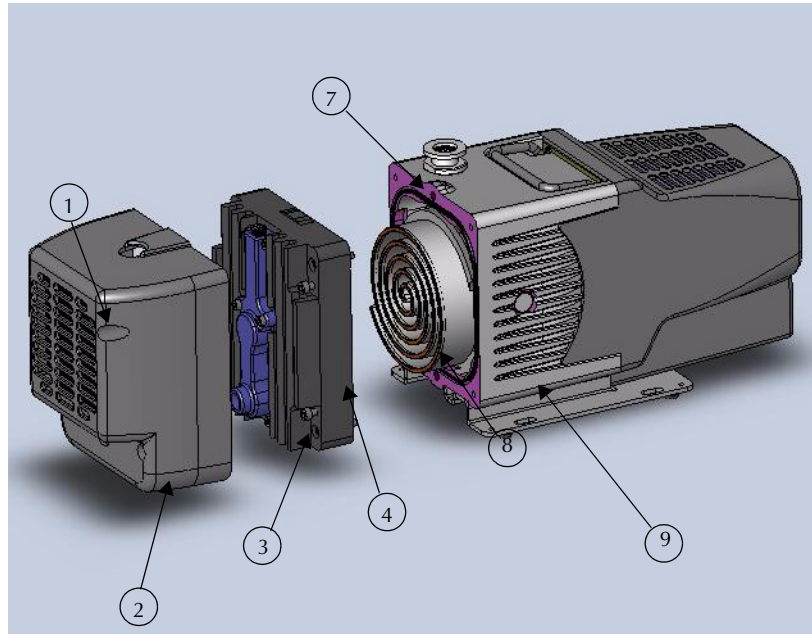

Figure 5 Exploded View of Pump Body

- | | |
|--------------------------------|---|
| 1. Front Cowling Bolts; M5 (4) | 2. Front Cowling |
| 3. Frame Bolts; M5 (4) | 4. Outboard Housing |
| 5. Tip Seals (Not shown) | 6. Main O-ring Parker No. 2-160 (Not shown) |
| 7. Locating Pins (2) | 8. Orbiting Scroll |
| 9. Frame | |

To test the pump:

1. Run the pump for about 5 seconds. Verify that the front fan is running.
If you hear loud noises or observe labored operation, this indicates that the tip seal or main O-ring are possibly out of place.
2. Disassemble and repair as necessary.
The pump is now ready to return to service.

NOTE



Newly installed tip seals may require several hours of run time to seat properly and enable the pump to meet speed and base pressure specifications.

Pump Module Replacement

The parts and tools required to replace the pump module include:

- Replacement Module Kit P/N IDP3
- 4 mm Allen wrench

Figure 6 on page 13 shows the various components involved in pump module replacement.

To replace the pump module:

1. Disconnect the pump from electrical power and disconnect the power cord from the power cord socket.
2. Stand the pump on the fan cowling (cover the work surface to protect the pump finish).
3. Loosen the four M5 captive screws (item 1) that hold the motor cowling in place (item 2), but do not remove the motor cowling.
4. Stand the pump on the motor cowling (cover the work surface to protect the pump finish).
5. Remove the four M5 socket head screws (item 3) that secure the fan cowling (item 4).

IDP-3 Dry Scroll Vacuum Pump

6. Remove the fan cowling, disconnect the electrical connector, and set the cowling aside.
7. Remove the four M5 socket head screws (item 5) that secure the base plate (item 6); remove the base plate, and set aside.
8. Lay the pump on its side and slide the motor cowling off the pump. Disconnect the electrical connector and set the cowling aside.
9. Remove the four M6 button head screws (item 7) that secure the motor to the pump module and set the motor aside.
10. Install the new coupling spider (item 8) to the coupling (motor side or pump module side) and install the motor to the replacement pump module with the label facing up (in the same direction as the inlet flange of the pump module). Secure the motor with four M6 button head screws.
11. Reconnect the electrical connector on the motor cowling to the motor.
12. Tuck the electrical connector behind the aluminum plate mounted to the motor cowling (item 9) and slide the motor cowling into place.
13. Holding the motor cowling in place, stand the pump on the end of the motor cowling with the exhaust fitting pointing up.
14. Reinstall the base plate with four M5 socket head screws.
15. Connect the electrical connector on the fan cowling to the wiring harness and reinstall the fan cowling with four M5 socket head screws.
16. Holding the motor cowling in place, stand the pump on the fan cowling.
17. Tighten the four M5 captive screws to secure the motor cowling.
18. Reattach the power cord and confirm proper operation.

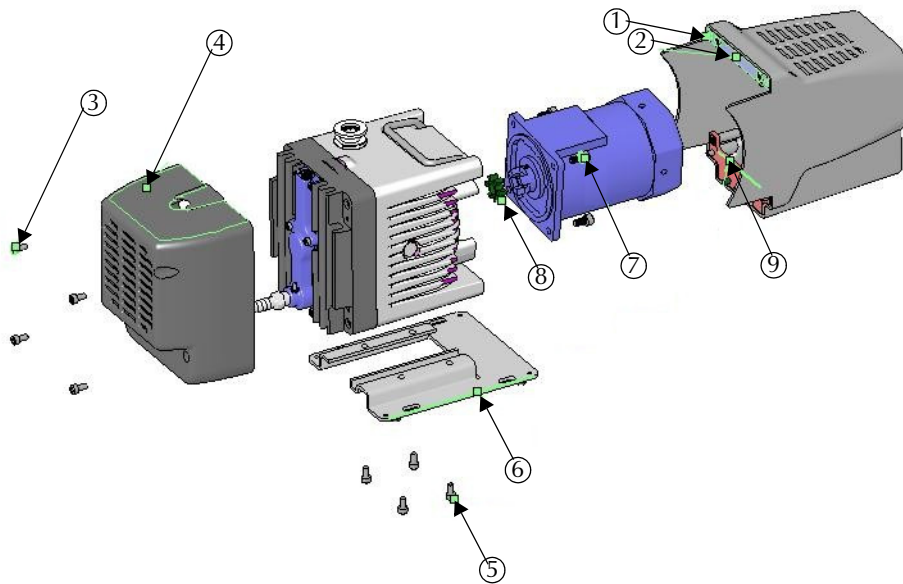

Figure 6 Module Replacement - Exploded View

IDP-3 Dry Scroll Vacuum Pump

This page intentionally left blank.

Request for Return Health and Safety Certification



1. Return authorization numbers (RA#) **will not** be issued for any product until this Certificate is completed and returned to a Varian, Inc. Customer Service Representative.
2. Pack goods appropriately and drain all oil from rotary vane and diffusion pumps (for exchanges please use the packing material from the replacement unit), making sure shipment documentation and package label clearly shows assigned Return Authorization Number (RA#) VVT cannot accept any return without such reference.
3. Return product(s) to the nearest location:

4. If a product is received at Varian, Inc. in a contaminated condition, **the customer is held responsible** for all costs incurred to ensure the safe handling of the product, and **is liable** for any harm or injury to Varian, Inc. employees occurring as a result of exposure to toxic or hazardous materials present in the product.

<i>CUSTOMER INFORMATION</i>			
Company name:			
Contact person:	Name:	Tel:.....	
	Fax:	E-mail:	
Ship method:	Shipping Collect #:	P.O.#:	USA only: <input type="checkbox"/> Taxable <input type="checkbox"/> Non-taxable
Customer ship to:	Customer bill to:

PRODUCT IDENTIFICATION

Product Description	Varian, Inc. Part Number	Varian, Inc. Serial Number

TYPE OF RETURN (check appropriate box)

<input type="checkbox"/> Paid Exchange	<input type="checkbox"/> Paid Repair	<input type="checkbox"/> Warranty Exchange	<input type="checkbox"/> Warranty Repair	<input type="checkbox"/> Loaner Return
<input type="checkbox"/> Credit	<input type="checkbox"/> Shipping Error	<input type="checkbox"/> Evaluation Return	<input type="checkbox"/> Calibration	<input type="checkbox"/> Other

HEALTH and SAFETY CERTIFICATION

VARIAN, INC. CANNOT ACCEPT ANY BIOLOGICAL HAZARDS, RADIOACTIVE MATERIAL, ORGANIC METALS, OR MERCURY AT ITS FACILITY. CHECK ONE OF THE FOLLOWING:		
<input type="checkbox"/> I confirm that the above product(s) has (have) NOT pumped or been exposed to any toxic or dangerous materials in a quantity harmful for human contact.		
<input type="checkbox"/> I declare that the above product(s) has (have) pumped or been exposed to the following toxic or dangerous materials in a quantity harmful for human contact (<u>Must be filled in</u>):		
Print Name.....	Signature	Date

PLEASE FILL IN THE FAILURE REPORT SECTION ON THE NEXT PAGE

Do not write below this line

Notification (RA) #:..... Customer ID #: Equipment #:

Request for Return Health and Safety Certification



FAILURE REPORT

(Please describe in detail the nature of the malfunction to assist us in performing failure analysis):

TURBO PUMPS AND TURBOCONTROLLERS

Claimed Defect	Position	Parameters
<input type="checkbox"/> Does not start <input type="checkbox"/> Does not spin freely <input type="checkbox"/> Does not reach full speed <input type="checkbox"/> Mechanical Contact <input type="checkbox"/> Cooling defective	<input type="checkbox"/> Noise <input type="checkbox"/> Vibrations <input type="checkbox"/> Leak <input type="checkbox"/> Overtemperature <input type="checkbox"/> Clogging	<input type="checkbox"/> Vertical <input type="checkbox"/> Horizontal <input type="checkbox"/> Upside-down <input type="checkbox"/> Other
		Power: Rotational Speed: Current: Inlet Pressure: Temp 1: Foreline Pressure: Temp 2: Purge flow: Operation Time:
Describe Failure:		
Turbocontroller Error Message:		

ION PUMPS/CONTROLLERS

<input type="checkbox"/> Bad feedthrough <input type="checkbox"/> Vacuum leak <input type="checkbox"/> Error code on display	<input type="checkbox"/> Poor vacuum <input type="checkbox"/> High voltage problem <input type="checkbox"/> Other
Describe failure:	
Customer application:	

VALVES/COMPONENTS

<input type="checkbox"/> Main seal leak <input type="checkbox"/> Solenoid failure <input type="checkbox"/> Damaged sealing area	<input type="checkbox"/> Bellows leak <input type="checkbox"/> Damaged flange <input type="checkbox"/> Other
Describe failure:	
Customer application:	

LEAK DETECTORS

<input type="checkbox"/> Cannot calibrate <input type="checkbox"/> Vacuum system unstable <input type="checkbox"/> Failed to start	<input type="checkbox"/> No zero/high background <input type="checkbox"/> Cannot reach test mode <input type="checkbox"/> Other
Describe failure:	
Customer application:	

INSTRUMENTS

<input type="checkbox"/> Gauge tube not working <input type="checkbox"/> Communication failure <input type="checkbox"/>	<input type="checkbox"/> Display problem <input type="checkbox"/> Degas not working <input type="checkbox"/> Error code on display <input type="checkbox"/>
Describe failure:	
Customer application:	

ALL OTHER VARIAN, INC.

<input type="checkbox"/> Pump doesn't start <input type="checkbox"/> Doesn't reach vacuum <input type="checkbox"/> Pump seized	<input type="checkbox"/> Noisy pump (describe) <input type="checkbox"/> Overtemperature <input type="checkbox"/> Other
Describe failure:	
Customer application:	

DIFFUSION PUMPS

<input type="checkbox"/> Heater failure <input type="checkbox"/> Doesn't reach vacuum <input type="checkbox"/> Vacuum leak	<input type="checkbox"/> Electrical problem <input type="checkbox"/> Cooling coil damage <input type="checkbox"/> Other
Describe failure:	
Customer application:	