

Chemtech Scientific provides access to this content as a courtesy.
We do not own the content contained in this document.
All rights and credit go directly to its rightful owners.
www.chemtechsci.com
Call us at: 484-424-9415



MS-301
MS-631
High Capacity
Rotary Vane Pumps

Model 949-5001
Model 949-5002
Model 949-5101
Model 949-5102
Model 949-5201
Model 949-5202
Model 949-5301
Model 949-5302

(I) *MANUALE DI ISTRUZIONI*
(D) *BEDIENUNGSHANDBUCH*
(F) *NOTICE DE MODE D'EMPLOI*
(GB) *INSTRUCTION MANUAL*

High Capacity Rotary Vane Pumps

MS-301

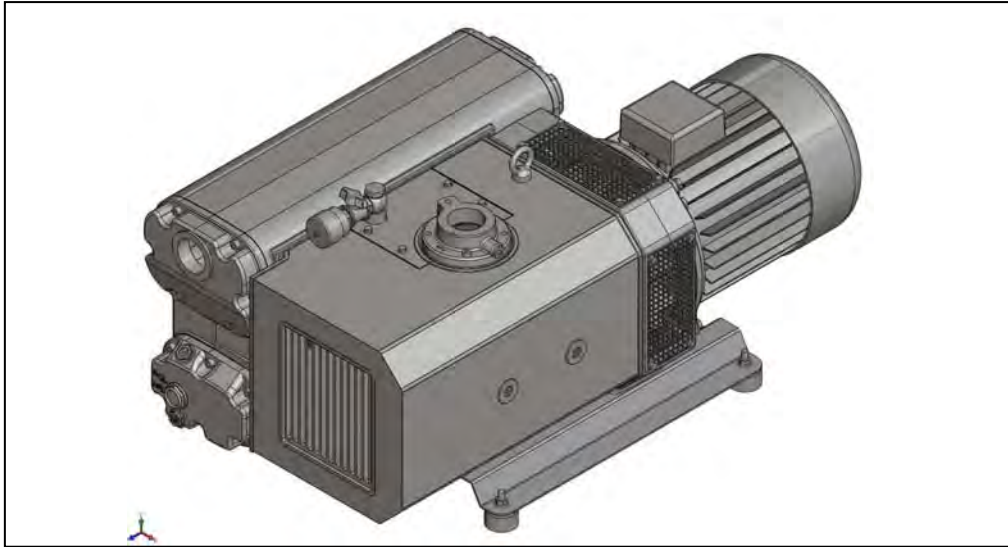

MS-631

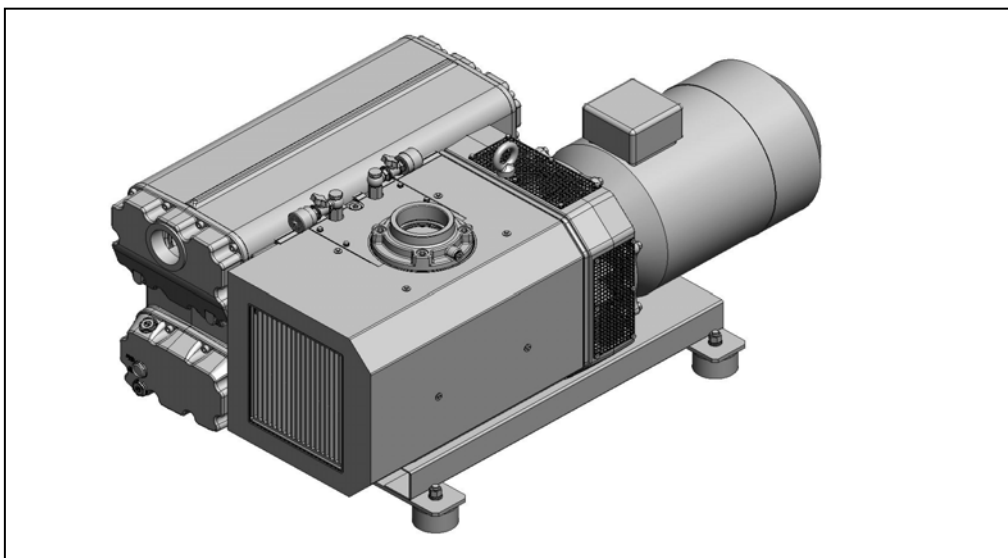

vacuum technologies

Dear Customer,

Thank you for purchasing a VARIAN vacuum product. At VARIAN Vacuum Technologies we make every effort to ensure that you will be satisfied with the product and/or service you have purchased.

As part of our Continuous Improvement effort, we ask that you report to us any problem you may have had with the purchase or operation of our product. On the back side you find a Corrective Action Request form that you may fill out in the first part and return to us.

This form is intended to supplement normal lines of communications and to resolve problems that existing systems are not addressing in an adequate or timely manner.

Upon receipt of your Corrective Action Request we will determine the Root Cause of the problem and take the necessary actions to eliminate it. You will be contacted by one of our employees who will review the problem with you and update you, with the second part of the same form, on our actions.

Your business is very important to us. Please, take the time and let us know how we can improve.

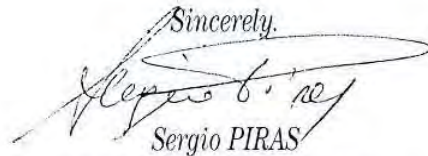

Sincerely,



Sergio PIRAS

*Vice President and General Manager
VARIAN Vacuum Technologies*

Note: Fax or mail the Customer Request for Action (see backside page) to VARIAN Vacuum Technologies (Torino) - Quality Assurance or to your nearest VARIAN representative for onward transmission to the same address.

ISTRUZIONI PER L'USO	1
GEBRAUCHSANLEITUNG	4
MODE D'EMPLOI	7
INSTRUCTIONS FOR USE	10
TECHNICAL INFORMATION	13
SECTION I	13
TECHNICAL DESCRIPTION	13
TECHNICAL DATA	14
Dimensions	15
SAFETY PRECAUTIONS	18
TRANSPORT AND HANDLING	18
Lifting	18
Unpacking and components control	19
Storage	19
SECTION II	20
INSTALLATION AND OPERATION	20
Assembling	20
Gas Ballast	20
Positioning	20
CONNECTIONS TO THE INLET AND EXHAUST FLANGES	21
Connection to the vacuum system	21
Discharge air pipe line installation	22
Electrical connection	22
Suggestions for use	23
Water vapour suction	23
STOPPING THE PUMP	23
SAFETY RULES	23
WARNING NOTES 	23
CAUTION NOTES 	24
MAINTENANCE ACTIONS	24
LUBRICANTS	25
SECTION III	27
SERVICING	27
General information	27
Pump Parts for MS-301	31
Pump Parts for MS-631	38
Oil change procedure	40
Float valve cleaning procedure	41
Exhaust filters replacement procedure	41
Oil separator change procedure	41

Gas ballast felt disk change procedure	41
Coupling elastic element replacement procedure	41
Pump overhaul procedure	42
SPARE PARTS	42
Spares necessary for normal servicing	42
How to order spare parts	42
Orderable parts	42
DE-COMMISSIONING	42
RETURN FOR REPAIR	43
TROUBLESHOOTING	43

INFORMAZIONI GENERALI

Questa apparecchiatura è destinata ad uso professionale. L'utilizzatore deve leggere attentamente il presente manuale di istruzioni ed ogni altra informazione addizionale fornita dalla Varian prima dell'utilizzo dell'apparecchiatura. La Varian si ritiene sollevata da eventuali responsabilità dovute all'inosservanza totale o parziale delle istruzioni, ad uso improprio da parte di personale non addestrato, ad interventi non autorizzati o ad uso contrario alle normative nazionali specifiche.

Le MS-301 e MS-631 High Capacity Rotary Vane Pumps sono delle pompe rotative monostadio a palette, a tenuta in bagno d'olio, azionate da un motore elettrico trifase.

Queste pompe da alto vuoto sono adatte al pompaggio di gas non corrosivi.

Nei paragrafi seguenti sono riportate tutte le informazioni necessarie a garantire la sicurezza dell'operatore durante l'utilizzo dell'apparecchiatura. Informazioni dettagliate sono fornite nell'appendice "Technical information".

Questo manuale utilizza le seguenti convenzioni:



PERICOLO!

I messaggi di pericolo attirano l'attenzione dell'operatore su una procedura o una pratica specifica che, se non eseguita in modo corretto, potrebbe provocare gravi lesioni personali.



ATTENZIONE!

I messaggi di attenzione sono visualizzati prima di procedure che, se non osservate, potrebbero causare danni all'apparecchiatura.

NOTA

Le note contengono informazioni importanti estrapolate dal testo.

IMMAGAZZINAMENTO

Durante il trasporto e l'immagazzinamento delle pompe non devono essere superate le seguenti condizioni ambientali:

- temperatura: da -20 °C a +70 °C
- umidità relativa: 0 - 95% (non condensante)

PREPARAZIONE PER L'INSTALLAZIONE

La pompa viene fornita in un imballo protettivo; se si presentano segni di danni, che potrebbero essersi verificati durante il trasporto, contattare l'ufficio vendite locale.

Il peso dell'imballo comprensivo della pompa è di circa 200 Kg per la MS-301 e di circa 640 Kg per la MS-631.

Durante l'operazione di disimballaggio, prestare particolare attenzione a non lasciar cadere la pompa e a non sottoporla ad urti o vibrazioni.

Non disperdere l'imballo nell'ambiente. Il materiale è completamente riciclabile e risponde alla direttiva CEE 85/399 per la tutela dell'ambiente.

NOTA

La pompa non può essere danneggiata rimanendo semplicemente esposta all'atmosfera. Si consiglia comunque di mantenerla chiusa fino al momento dell'installazione sul sistema onde evitare eventuale inquinamento da polvere.



INSTALLAZIONE

Non installare e/o utilizzare la pompa in ambienti esposti ad agenti atmosferici (pioggia, gelo, neve), polveri, gas aggressivi, in ambienti esplosivi o con elevato rischio di incendio.

Durante il funzionamento è necessario che siano rispettate le seguenti condizioni ambientali:

- temperatura: da +12 °C a +40 °C
- umidità relativa: 0 - 95% (non condensante)

**PERICOLO!**

Per proteggere contro corto-circuiti o sovraccarichi, è necessario installare un interruttore automatico sulla linea d'alimentazione principale verso la pompa, di capacità adeguata. La capacità dell'interruttore deve essere compatibile con i dati indicati sulla targhetta del motore effettivamente installato e deve essere scelto da chi effettua l'installazione. Il collegamento deve essere effettuato adottando tutte le vigenti norme applicabili.

**ATTENZIONE!**

Prima di avviare la pompa occorre procedere al rifornimento di olio lubrificante, poiché la pompa viene fornita scarica.

**PERICOLO!**

Togliere i tappi di protezione posti sulle flange di aspirazione e scarico prima di ogni operazione. L'aria contenuta all'interno della pompa, in caso di accensione involontaria, può proiettarli violentemente contro l'operatore e ferirlo.

**PERICOLO!**

Durante l'installazione, prestare la massima attenzione che la flangia di aspirazione sia collegata alla camera da evacuare e che la flangia di scarico non sia tappata (vedere le figure seguenti). Prestare la massima attenzione a non invertire lo scarico con la mandata. La massima pressione interna al contenitore dell'olio non deve superare 1,5 bar (assoluta). L'inosservanza di queste precauzioni può causare danni alla pompa ed all'operatore.

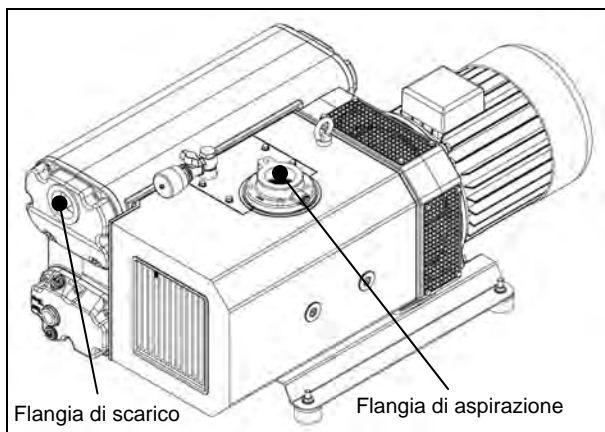

MS-301

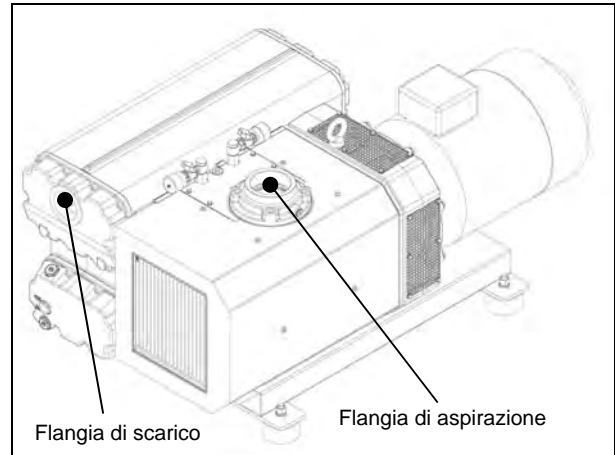

MS-631

**ATTENZIONE!**

Controllare che la tensione di alimentazione corrisponda al campo di valori indicati sulla targhetta del motore.

Collegare la pompa all'alimentazione.

USO

L'accensione della pompa non richiede particolari manovre; è sufficiente collegarla all'alimentazione elettrica perché la pompa inizi ad operare. Per il corretto collegamento fare riferimento allo schema elettrico fornito con la pompa.

**PERICOLO!**

La pompa è progettata per operare con fluidi neutri o non corrosivi. È assolutamente vietato l'impiego con sostanze potenzialmente esplosive o infiammabili.

**ATTENZIONE!**

Nei motori trifase, un'inversione di polarità provoca l'inversione del senso di rotazione della pompa, con conseguenti possibili danni di natura meccanica.

MANUTENZIONE

Il personale addetto alla condotta ed alla manutenzione della pompa deve essere ben addestrato e deve avere un'approfondita conoscenza delle norme antinfortunistiche.

**PERICOLO!**

Le alte tensioni possono causare morte al contatto. Operare sempre con la massima cautela e secondo le norme antinfortunistiche in vigore.

**PERICOLO!**

Quando la macchina è alimentata prestare attenzione per la presenza di parti in movimento e di alta tensione.

**PERICOLO!**

Nel caso si debba procedere ad operazioni di manutenzione della pompa al termine di un prolungato periodo di esercizio, è necessario lasciarla raffreddare, poiché la temperatura esterna può superare gli 80 °C.

**PERICOLO!**

Escludere sempre l'alimentazione della pompa prima di compiere operazioni di manutenzione. Apporre specifici cartelli di avvertenza: APPARECCHIATURA IN MANUTENZIONE - NON INSERIRE L'ALIMENTAZIONE, in corrispondenza dell'interruttore di alimentazione. Al termine ripristinare i dispositivi di sicurezza.

**PERICOLO!**

Non effettuare la sostituzione dell'olio subito dopo l'arresto della macchina, in quanto la temperatura dello stesso può essere elevata.

NOTA

Prima di rispedire al costruttore una pompa per riparazioni è indispensabile compilare e far pervenire al locale ufficio vendite la scheda "Health and Safety Certification" allegata al presente manuale di istruzioni. Copia della stessa deve essere inserita nell'imballo della pompa prima della spedizione.

Qualora una pompa dovesse essere rottamata, procedere alla sua eliminazione nel rispetto delle normative nazionali specifiche.

SMALTIMENTO**Significato del logo "WEEE" presente sulle etichette**

Il simbolo qui sotto riportato applicato in ottemperanza alla direttiva CE denominata "WEEE".

Questo simbolo (**valido solo per i paesi della Comunità Europea**) indica che il prodotto sul quale è applicato, **NON** deve essere smaltito insieme ai comuni rifiuti domestici o industriali, ma deve essere avviato ad un sistema di raccolta differenziata.

Si invita pertanto l'utente finale a contattare il fornitore del dispositivo, sia esso la casa madre o un rivenditore, per avviare il processo di raccolta e smaltimento, dopo opportuna verifica dei termini e condizioni contrattuali di vendita.

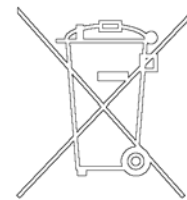

ALLGEMEINE HINWEISE

Dieses Gerät ist für den professionellen Gebrauch bestimmt. Vor dem Gebrauch soll der Benutzer dieses Handbuch sowie alle weiteren von Varian mitgelieferten Zusatzinformationen genau lesen. Bei vollständiger bzw. teilweiser Nichtbeachtung der enthaltenen Hinweise, unsachgemäßem Gebrauch durch ungeschultes Personal, nicht autorisierten Eingriffen und Benutzung unter Missachtung der nationalen Bestimmungen übernimmt Firma Varian keinerlei Haftung.

Die Pumpen-301 e MS-631 High Capacity Rotary Vane Pumps sind dichte ölbadgeschmierte einstufige Flügelzellenpumpen, die von einem Dreiphasenstrommotor betätigt werden.

Diese Hochvakuumpumpen eignen sich für das Pumpen von nicht korrosiven Gasen.

In den folgenden Abschnitten sind alle erforderlichen Informationen für die Sicherheit des Bedieners bei der Verwendung des Geräts aufgeführt. Detaillierte technische Informationen sind im Anhang "Technical Information" enthalten.

In dieser Gebrauchsanleitung werden Sicherheitshinweise folgendermaßen hervorgehoben:



GEFAHR!

Diese Warnung weist auf gefährliche Arbeitsschritte hin, die bei unsachgemäßer Durchführung das Risiko von Personenschäden bergen.



ACHTUNG!

Diese Warnung weist auf Arbeitsschritte hin, die das Risiko von Schäden am Gerät bergen.

ANMERKUNG

Die Anmerkungen enthalten wichtige Informationen, die aus dem Text hervorgehoben werden.

LAGERUNG

Während des Transports und der Lagerung der Pumpen sollen die folgenden Umgebungsbedingungen gegeben sein:

- Temperatur: -20 °C bis +70 °C
- Relative Feuchtigkeit: 0 – 95 % (niederschlagsfrei)

VOR DER INSTALLATION

Die Pumpe wird in einer Schutzverpackung geliefert. Eventuelle Transportschäden sind der zuständigen örtlichen Verkaufsstelle zu melden.

Das Gewicht der Verpackung einschließlich der Pumpe beträgt zirka 200 kg im Falle des Modells MS-301 und zirka 640 kg im Falle des Modells MS-631.

Beim Auspacken ist darauf zu achten, dass die Pumpe nicht fallengelassen oder Stößen oder Vib-

rationen ausgesetzt wird.

Das Verpackungsmaterial ist ordnungsgemäß zu entsorgen. Es ist vollständig recyclebar und entspricht der EG-Richtlinie 85/399 für den Umweltschutz.

ANMERKUNG

Die Pumpe kann, wenn sie einfach der Atmosphäre ausgesetzt ist, nicht beschädigt werden. Sie sollte jedoch bis zur Installation an der Anlage geschlossen bleiben, um Verunreinigungen durch Staub zu vermeiden.



INSTALLATION

Die Pumpe darf nicht in Umgebungen installiert und/oder benutzt werden, die ungeschützt vor Witterungsbedingungen (Regen, Frost, Schnee), Staub und aggressiven Gasen sind und in denen Explosions- oder erhöhte Brandgefahr besteht.

Während des Betriebs sollen die folgenden Umgebungsbedingungen gegeben sein:

- Temperatur: +12 °C bis +40 °C
- Relative Feuchtigkeit: 0 - 95% (niederschlagsfrei)



GEFAHR!

Um vor Kurzschlüssen oder Überlastungen zu schützen, muss ein automatischer Schalter an der Hauptspeisungsleitung zur Pumpe hin mit einer geeigneten Kapazität installiert werden. Die Kapazität des Schalters muss mit den auf dem Schild des effektiv installierten Motors angegebenen Daten übereinstimmen und von dem Installateur gewählt werden. Der Anschluss muss bei Einhaltung aller geltenden diesbezüglichen Vorschriften erfolgen.



ACHTUNG!

Vor dem Pumpenstart muss die Pumpe mit Schmieröl gefüllt werden, da sie ohne geliefert wird.



GEFAHR!

Vor Aufnahme jeglicher Arbeiten sind die Schutzkappen an den Saug- und Druckflanschen zu entfernen. Die im Pumpeninnern enthaltene Luft könnte diese bei unbeabsichtigter Einschaltung gegen den Bediener schleudern.



GEFAHR!

Bei der Installation ist unbedingt darauf zu achten, dass der Saugflansch an die zu entleerende Kammer angeschlossen ist und der Ablassflansch nicht verschlossen ist (siehe folgende Abbildungen). Bitte sehr darauf achten, dass der Ablass nicht mit der Ansaugung verwechselt wird. Der Druck im Ölbehälter darf nicht größer als 1,5 bar (abs) sein. Bei Nichtbeachtung dieser Anweisungen besteht Schadensgefahr für die Pumpe und die Bedienerperson.

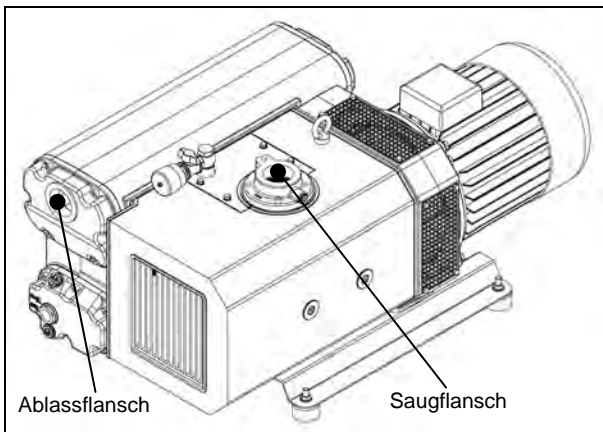

MS-301

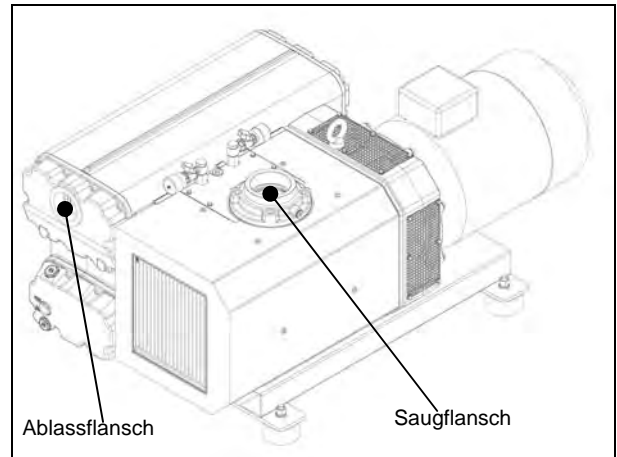

MS-631



ACHTUNG!

Vergewissern Sie sich, dass die Versorgungsspannung mit dem Wertbereich auf dem Typenschild des Motors übereinstimmt.

Die Pumpe an das Versorgungsnetz anschließen.

GEBRAUCH

Das Einschalten der Pumpe fordert keine besonderen Vorgänge, es ist ausreichend, diese mit Strom zu verbinden, damit sie zu pumpen beginnt. Für den korrekten Anschluss beziehen Sie sich bitte auf den mit der Pumpe gelieferten Schaltplan.



GEFAHR!

Die Pumpe ist für den Betrieb mit neutralen und nicht korrosiven Fluiden konzipiert. Der Einsatz mit potentiell explosions- oder feuergefährlichen Substanzen ist streng verboten.



ACHTUNG!

In den Dreiphasenmotoren ruft eine Polaritätsumkehrung die Umkehrung der Pumpendrehrichtung hervor und kann somit eventuelle mechanische Schäden verursachen.

WARTUNG

Das für den Betrieb und die Wartung zuständige Personal soll geschult sein und über eine solide Kenntnis der Unfallschutzvorschriften verfügen.



GEFAHR!

Hochspannungen können bei Kontakt tödliche Folgen haben. Es ist stets mit größter Vorsicht und gemäß den geltenden Unfallschutzvorschriften vorzugehen.



GEFAHR!

Bei eingeschaltetem Gerät ist auf Bewegungs- und Hochspannungsteile zu achten.



GEFAHR!

Falls die Pumpe im Anschluss an den Betrieb gewartet werden soll, ist abzuwarten, bis sie abgekühlt ist, da ihre Oberfläche eine Temperatur von 80 °C überschreiten kann.



GEFAHR!

Vor Wartungsarbeiten ist die Pumpe stets energiefrei zu schalten. Am Netzschalter sind spezielle Warnschilder "INSTANDHALTUNG AM GERÄT – NICHT EINSCHALTEN" anzubringen. Nach Abschluss der Arbeiten sind die Sicherheitseinrichtungen wieder zu aktivieren.



GEFAHR!

Keine Ölwechsel unmittelbar nach Stillsetzung des Gerätes vornehmen, da die Öltemperatur sehr hoch sein kann.

ANMERKUNG

Bevor dem Hersteller eine Pumpe zur Reparatur zurückgesandt wird, ist das Formular "Sicherheit und Gesundheit" in der Anlage zum vorliegenden Handbuch auszufüllen und der lokalen Verkaufsstelle zuzustellen. Eine Kopie des Formulars ist der Pumpenverpackung vor dem Versand beizulegen.

Bei eventueller Verschrottung einer Pumpe ist diese entsprechend der einschlägigen nationalen Vorschriften zu entsorgen.

ENTSORGUNG

Bedeutung des "WEEE"-Logos auf den Etiketten

Das folgende Symbol ist in Übereinstimmung mit der EU-Richtlinie WEEE (Waste Electrical and Electronic Equipment) angebracht.

Dieses Symbol (**nur in den EU-Ländern gültig**) zeigt an, dass das betreffende Produkt nicht zusammen mit Haushaltsmüll entsorgt werden darf sondern einem speziellen Sammelsystem zugeführt werden muss.

Der Endabnehmer sollte daher den Lieferanten des Geräts – d. h. die Muttergesellschaft oder den Wiederverkäufer – kontaktieren, um den Entsorgungsprozess zu starten, nachdem er die Verkaufsbedingungen geprüft hat.

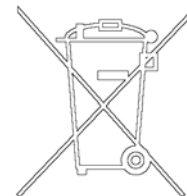

INFORMATION GÉNÉRALE

Cet appareil a été conçu en vue d'une utilisation professionnelle. Il est conseillé à l'utilisateur de lire attentivement cette notice ainsi que toute autre information fournie par Varian avant de l'utiliser. Varian décline toute responsabilité en cas de non-respect total ou partiel des instructions fournies, d'utilisation incorrecte de la part du personnel non formé, d'opérations non autorisées ou d'un emploi contraire aux réglementations nationales spécifiques.

Les MS-301 et MS-631 High Capacity Rotary Vane Pumps sont des pompes rotatives monoétagées, à palettes, étanches en bain d'huile, actionnées par un moteur électrique triphasé.

Ces pompes à haut vide sont adaptées au pompage de gaz non corrosifs.

Les paragraphes suivants fournissent toute l'information nécessaire pour garantir la sécurité de l'opérateur pendant l'utilisation de l'appareil. Des renseignements plus détaillés se trouvent dans l'appendice «Technical information».

Cette notice utilise les signes conventionnels suivants:



DANGER!

Les messages de danger attirent l'attention de l'opérateur sur une procédure ou une manœuvre spéciale dont la mauvaise exécution risque de provoquer de graves lésions.



ATTENTION!

Les messages d'attention apparaissent avant certaines procédures dont le non-respect pourrait endommager sérieusement l'appareil.

NOTE

Les notes contiennent des renseignements importants, isolés du texte.

EMMAGASINAGE

Pendant le transport et l'emménagement des pompes, veiller à respecter les conditions environnementales suivantes:

- température: de -20 °C à +70 °C
- humidité relative: 0 - 95 % (sans condensation)

PRÉPARATION POUR L'INSTALLATION

La pompe est fournie dans un emballage de protection; si l'on constate des marques de dommages pouvant s'être produites pendant le transport, contacter aussitôt le bureau de vente local.

Le poids total de l'emballage avec la pompe est d'environ 200 Kg pour la MS-301 et d'environ 640 Kg pour la MS-631.

Pendant l'opération d'ouverture de l'emballage, veiller tout particulièrement à ne pas laisser tomber la pompe et à ne lui faire subir aucun choc ni aucune vibration.

Ne pas jeter l'emballage dans la nature. Le matériel est entièrement recyclable et il est conforme à la directive CEE 85/399 en matière de protection de l'environnement.

NOTE

La pompe ne peut être endommagée en restant simplement exposée à l'atmosphère. Il est de toute façon conseillé de la garder dans son emballage jusqu'au moment de sa mise en place sur le système afin d'éviter toute pollution due à la poussière.



INSTALLATION

Ne pas installer et/ou utiliser la pompe dans des milieux exposés aux agents atmosphériques (pluie, gel, neige), à des poussières, à des gaz agressifs ainsi que dans des milieux explosifs ou à risque élevé d'incendie.

Pendant le fonctionnement, il est nécessaire de respecter les conditions environnementales suivantes:

- Température: de +12 °C à +40 °C
- Humidité relative: 0 - 95 % (sans condensation)



DANGER!

Afin de prévenir les risques de courts-circuits ou de surcharge, il est nécessaire d'installer un interrupteur automatique sur la ligne d'alimentation principale de la pompe, d'une capacité appropriée. La capacité de l'interrupteur doit être compatible avec les données figurant sur la plaque signalétique du moteur effectivement installé et doit être sélectionné par l'installateur. Le branchement doit être effectué dans le respect des normes en vigueur.



ATTENTION!

Avant toute utilisation de la pompe, celle-ci doit être ravitaillée en huile car elle est livrée vide.



DANGER!

Avant toute autre opération, retirer les bouchons de protection placés sur les brides d'aspiration et de vidange. En cas de mise en marche inopinée de l'appareil, l'air contenu à l'intérieur de la pompe peut les projeter contre l'opérateur et le blesser.



DANGER!

Pendant l'installation, faire très attention à ce que la bride d'aspiration soit reliée à la chambre à vider et que la bride de vidange ne soit pas bouchée (voir les figures ci-après).

Veiller attentivement à ne pas inverser l'entrée et la sortie de la pompe.

La pression maximale à l'intérieur du réservoir d'huile ne doit pas dépasser 1,5 bar (abs).

Le non-respect de ces précautions peut entraîner un danger pour l'opérateur et endommager la machine.

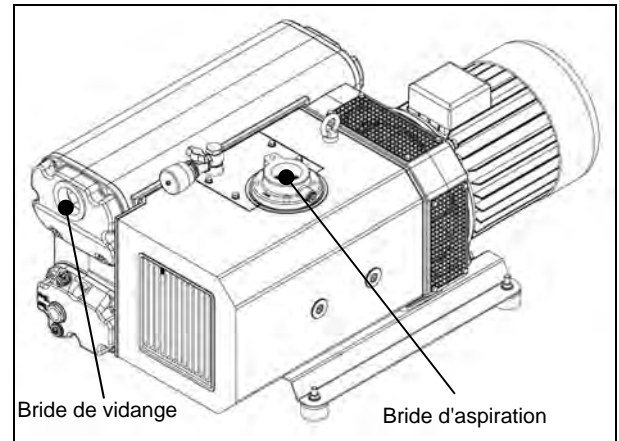

MS-301

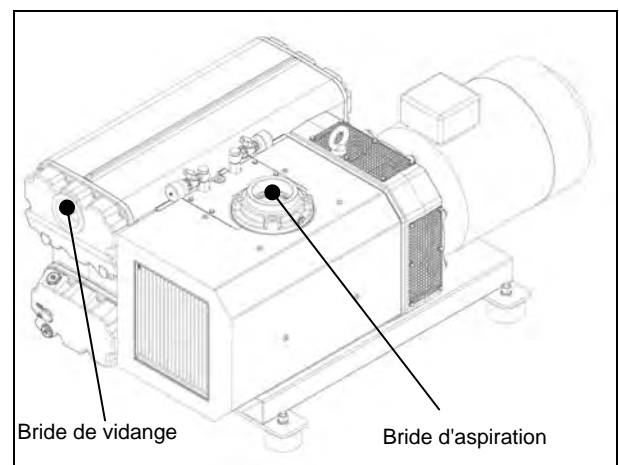

MS-631



ATTENTION!

Contrôler que la tension d'alimentation correspond à la gamme de tensions indiquées sur la plaquette du moteur.

Brancher la pompe à la source d'alimentation.

UTILISATION

La mise en marche de la pompe ne requiert aucune manœuvre particulière; il suffit de la brancher à l'alimentation électrique pour que la pompe démarre.

Pour un branchement correct, consultez le schéma électrique fourni.



DANGER!

La pompe a été conçue pour fonctionner avec des fluides neutres ou non corrosifs. L'emploi de substances potentiellement explosives ou inflammables est strictement interdit.



ATTENTION!

Sur les moteurs triphasés, une inversion des polarités entraîne une inversion du sens de rotation de la pompe et comporte des risques de dommages mécaniques.

MAINTENANCE

Le personnel chargé de la conduite et de la maintenance de la pompe doit avoir la formation nécessaire et posséder une connaissance approfondie des normes de prévention des accidents du travail.



DANGER!

Les hautes tensions peuvent entraîner la mort par contact. Veiller à toujours opérer avec le maximum de prudence et dans le respect des normes de prévention des accidents du travail en vigueur.



DANGER!

Lorsque la machine est sous tension, faire attention à la présence d'organes en mouvement et de haute tension.



DANGER!

En cas de devoir procéder à des opérations de maintenance de la pompe au terme d'une longue période de fonctionnement, il est indispensable de la laisser refroidir car sa température extérieure peut dépasser 80 °C.



DANGER!

Avant toute opération de maintenance, il est impératif de toujours couper l'alimentation de la pompe. Placer les panneaux spécifiques d'avertissement: APPAREIL EN COURS DE MAINTENANCE – NE PAS BRANCHER L'ALIMENTATION, près de l'interrupteur d'alimentation. Au terme des opérations de maintenance, restaurer les dispositifs de sécurité.



DANGER!

Ne pas effectuer la substitution d'huile immédiatement après l'arrêt de la machine car la température de celle-là peut être élevée.

NOTE

Avant de retourner une pompe au constructeur pour réparation, il est indispensable de remplir et d'adresser au bureau local de vente la fiche "Health and Safety Certification" jointe à la présente notice. Une copie de celle-ci devra être mise dans l'emballage de la pompe avant expédition.

En cas de mise au rebut de la pompe, procéder à son élimination conformément aux réglementations nationales en la matière.

MISE AU REBUT

Signification du logo "WEEE" figurant sur les étiquettes

Le symbole ci-dessous est appliqué conformément à la directive CE nommée "WEEE".

Ce symbole (**uniquement valide pour les pays de la Communauté européenne**) indique que le produit sur lequel il est appliqué NE doit PAS être mis au rebut avec les ordures ménagères ou les déchets industriels ordinaires, mais passer par un système de collecte sélective.

Après avoir vérifié les termes et conditions du contrat de vente, l'utilisateur final est donc prié de contacter le fournisseur du dispositif, maison mère ou revendeur, pour mettre en œuvre le processus de collecte et mise au rebut.

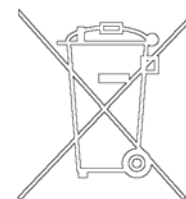

GENERAL INFORMATION

This equipment is destined for use by professionals. The user should read this instruction manual and any other additional information supplied by Varian before operating the equipment. Varian will not be held responsible for any events occurring due to non-compliance, even partial, with these instructions, improper use by untrained persons, non-authorized interference with the equipment or any action contrary to that provided for by specific national standards.

The -301 e MS-631 High Capacity Rotary Vane Pumps are single-stage, rotary vane pumps oil sealed, driven by a three-phase electric motor.

These high vacuum pumps are suitable for pumping non corrosive gases.

The following paragraphs contain all the information necessary to guarantee the safety of the operator when using the equipment. Detailed information is supplied in the appendix "Technical Information".

This manual uses the following standard protocol:



WARNING!

The warning messages are for attracting the attention of the operator to a particular procedure or practice which, if not followed correctly, could lead to serious injury.



CAUTION!

The caution messages are displayed before procedures which, if not followed, could cause damage to the equipment.

NOTE

The notes contain important information taken from the text.

STORAGE

When transporting and storing the pumps, the following environmental requirements should not be exceeded:

- temperature: from -20° to +70 °C
- relative humidity: 0 - 95% (non-condensing)

PREPARATION FOR INSTALLATION

The pump is supplied in a protective packing. If this shows signs of damage which may have occurred during transport, contact your local sales office.

The total weight of the pack, including the pump, is approx. 200 Kg for the MS-301 and approx. 640 Kg for the MS-631.

When unpacking the pump, be sure not to drop it and avoid any kind of sudden impact or shock vibration to it.

Do not dispose of the packing materials in an unauthorized manner. The material is 100% recyclable and complies with EEC Directive 85/399.

NOTE

Normal exposure to the environment cannot damage the pump. Nevertheless, it is advisable to keep it closed until it is installed in the system, thus preventing any form of pollution by dust.



INSTALLATION

Do not install or use the pump in an environment exposed to atmospheric agents (rain, snow, ice), dust, aggressive gases, or in explosive environments or those with a high fire risk.

During operation, the following environmental conditions must be respected:

- temperature: from +12 °C to +40 °C
- relative humidity: 0 - 95% (non-condensing)

⚠ WARNING!

To ensure short-circuit or overload protection, an automatic circuit breaker of appropriate capacity must be installed on the main power line towards the pump. The capacity of the switch must be compatible with the rating plate data of the motor actually installed and must be chosen by the installer. Connect by adopting all the current applicable rules and regulations.

👉 CAUTION!

Fill the pump with lubricating oil before starting it. The pump is supplied empty.

⚠ WARNING!

Take out the protective caps on the suction and exhaust flanges before doing anything else. In the event of an accidental start-up, the air inside the pump could violently expel the protective caps and harm the operator.

⚠ WARNING!

During installation, pay maximum attention that the suction flange is connected to the vacuum chamber and the exhaust flange is not closed (see figures below).

Be very careful not to invert exhaust and suction. Maximum pressure inside the oil container must not exceed 1.5 bar (abs.)

Non-observance of these precautions may be dangerous for the pump and the operator.

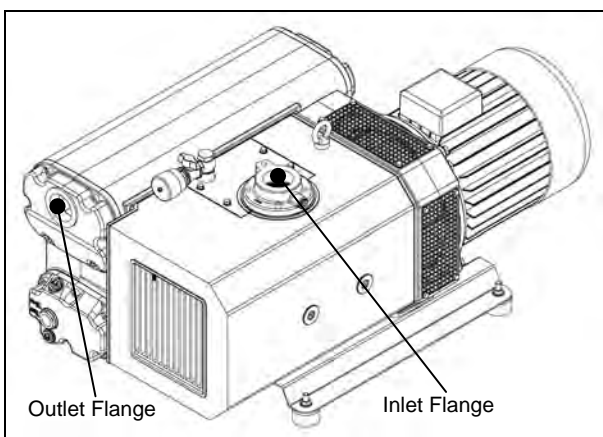

MS-301

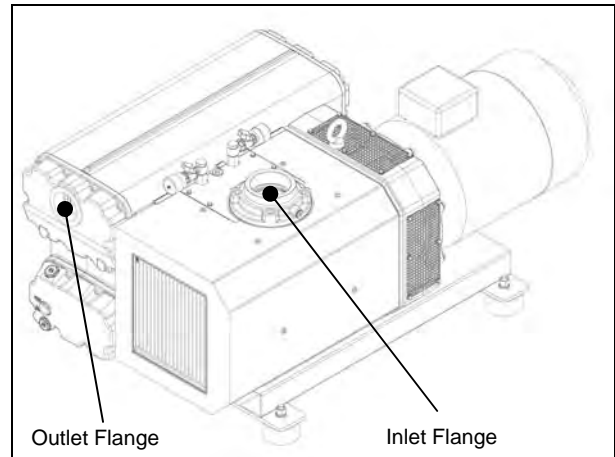

MS-631

👉 CAUTION!

Check that your electrical mains voltage corresponds to the range indicated on motor label.

Connect the pump to the power supply.

USE

There are no special procedures for switching the pump on. Simply connect to the electrical power supply to start it running.

Refer to the wiring diagram supplied with the pump for correct connection.

⚠ WARNING!

The pump is designed for operation with neutral or non-corrosive fluids. It is absolutely forbidden to use potentially explosive or flammable substances.

👉 CAUTION!

In three-phase motors, reversing the phase will reverse the sense of rotation of the pump. This may cause mechanical damage.

MAINTENANCE

Personnel responsible for pump operation and maintenance must be well-trained and must be aware of the accident prevention rules.

⚠ WARNING!

Death may result from contact with high voltages. Always take extreme care and observe the accident prevention regulations in force.

⚠ WARNING!

When machine is powered take care on account of moving parts and high voltages.

**WARNING!**

If you have to perform maintenance on the pump after a considerable time in operation, leave it to cool as temperature of the outer surface may be in excess of 80 °C.

**WARNING!**

Always disconnect the power supply to the pump before starting maintenance work. Place a special warning signs over the power supply breaker switch: **MACHINE UNDERGOING MAINTENANCE - DO NOT POWER ON.** When finished, remove the safety warning.

**WARNING!**

Do not change the oil immediately after stopping the machine as the oil temperature may still be high.

NOTE

Before returning the pump to the constructor for repairs the "Health and Safety Certification" sheet attached to this instruction manual must be filled-in and sent to the local sales office. A copy of the sheet must be inserted in the pump package before shipping.

If a pump is to be scrapped, it must be disposed of in accordance with the specific national standards.

DISPOSAL**Meaning of the "WEEE" logo found in labels**

The following symbol is applied in accordance with the EC WEEE (Waste Electrical and Electronic Equipment) Directive.

This symbol (**valid only in countries of the European Community**) indicates that the product it applies to must NOT be disposed of together with ordinary domestic or industrial waste but must be sent to a differentiated waste collection system. The end user is therefore invited to contact the supplier of the device, whether the Parent Company or a retailer, to initiate the collection and disposal process after checking the contractual terms and conditions of sale.

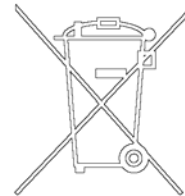

SECTION I**TECHNICAL DESCRIPTION**

The pumps series MS (MS-301 and MS-631) are single stage rotary vane vacuum pumps lubricated, with oil recirculation, driven by a flanged electrical motor, coupled by means of an elastic coupling.

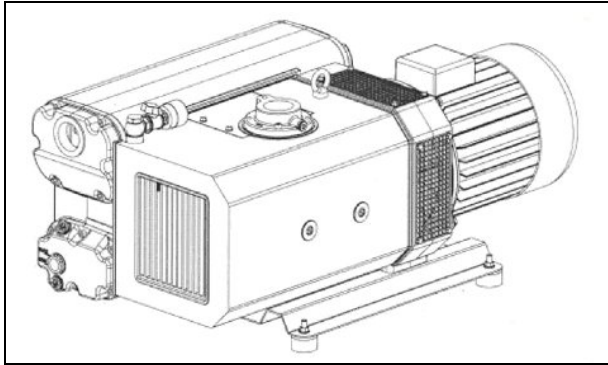

MS-301

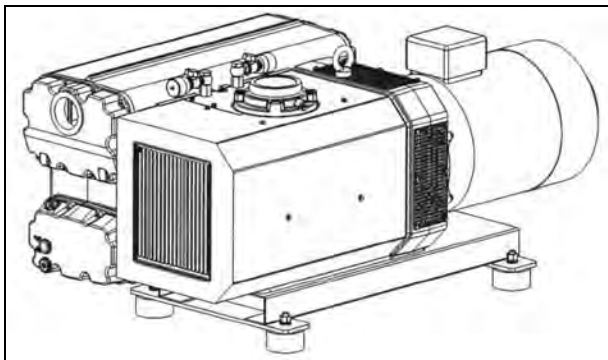

MS-631

These Varian vacuum pumps are suitable for pumping non corrosive gases.

The pumps series MS can reach:

- $\leq 8 \times 10^{-2}$ mbar (partial pressure) without gas ballast valve
- ≤ 0.7 mbar (ultimate total pressure) with gas ballast valve.



Cooling is achieved by means of an air/oil cooler, cooled with a centrifugal fan. At the pump inlet there is a mesh filter in order to protect it from solid parts having diameter larger than 1.5 mm. Furthermore, an integrated non return valve prevents the oil coming back and the return of air in the chamber to be pumped down during the stop phase.

In the tank there is a system of oil smokes separation from the discharged air (maximum residual 2PPM/weight corresponding to 2.4 mg/m^3).

The separated oil is recovered automatically by the pump.

A standard gas ballast valve prevents condensation inside the pump even when pumping down small quantity of vapour.

Here after are shown symbols used to identify the threaded ports;

-  This symbol identifies the inlet port
-  This symbol identifies the exhaust threaded port.

TECHNICAL DATA

The following table lists the main technical data of the series MS High Capacity Rotary Vane Pumps.

TECHNICAL DATA		UNITS	MS-301	MS-631
NOMINAL SPEED*		m ³ /h (at 50 Hz)	290	660
		m ³ /h (at 60 Hz)	350	790
ULTIMATE PRESSURE WITHOUT GAS BALLAST* (partial)		mbar	≤ 8 x 10 ⁻²	≤ 8 x 10 ⁻²
		Pascal	≤ 8	≤ 8
ULTIMATE PRESSURE WITH GAS BALLAST* (absolute)		mbar	≤ 0.7	≤ 0.7
		Pascal	≤ 70	≤ 70
MOTOR POWER/ROTATIONAL SPEED** (3ph)		kW (rpm) at 50 Hz	5.5 (1450)	15 (820)
		kW (rpm) at 60 Hz	7.5 (1750)	18.5 (1000)
ELECTRICAL MOTOR CHARACTERISTICS		at 50 Hz	IM B5 400/690 V ±10%	
		at 60 Hz	IM B5 480/828 V ±10%	
NOISE PRESSURE LEVEL (According to UNI EN ISO 2151 standard)		dB(A) at 50 Hz	72	71
		dB(A) at 60 Hz	76	73
WATER VAPOUR TOLERANCE	50 Hz	mbar	30	30
	60 Hz	mbar	40	40
WATER VAPOUR PUMPING CAPACITY	50 Hz	Kg/h	5	20
	60 Hz	Kg/h	7	30
OIL CAPACITY	min	l	6	19
	max	l	8	25
	nominal	l	7	22
WEIGHT	with 3 ph 50 Hz motor	Kg (lb)	190 (418.50)	575 (1266.52)
	with 3 ph 60 Hz motor	Kg (lb)	192 (422.91)	612 (1348.02)
	without motor (approx.***)	Kg (lb)	140 (308.37)	385 (848.02)
OPERATING TEMPERATURE RANGE		°C	12 – 40	12 – 40
INLET FLANGE		DN	2" gas / DN63 ISO-K	4" gas / DN100 ISO-K
EXHAUST FLANGE		DN	2" gas	4" gas
POWER SUPPLY VOLTAGE	50 Hz	V	230/400 ± 10%	400/690 ± 10%
	60 Hz	V	440/480	440/480
MAX INPUT POWER	50 Hz	VA (HP)	5.5 (7.4)	15 (20.1)
	60 Hz	VA (HP)	7.5 (10)	18.5 (24.8)
COMPLIANCE WITH:	EN 61010-1 2001 <i>Safety requirements for electrical equipment for measurement control and laboratory use</i> EN 61326-1 2006 <i>Electrical equipment for measurement control and laboratory use EMC requirements</i> EN 1012-2 2009 <i>Compressors and vacuum pumps - Safety requirements - Part 2: vacuum pumps</i> EN 12100-1 2005 <i>Safety of machinery - Basic concepts, general principles for design – Part 1: basic terminology, methodology</i> EN 12100-2 2005 <i>Safety of machinery - Basic concepts, general principles for design – Part 2: technical principles</i>			

• According to PNMSROP standard 6602

*** Depending from motor

** Valid for temperature up to 40 °C and altitudes lower than 1000 m

Dimensions

The following drawings show the pumps layout, dimensions and rotational direction:

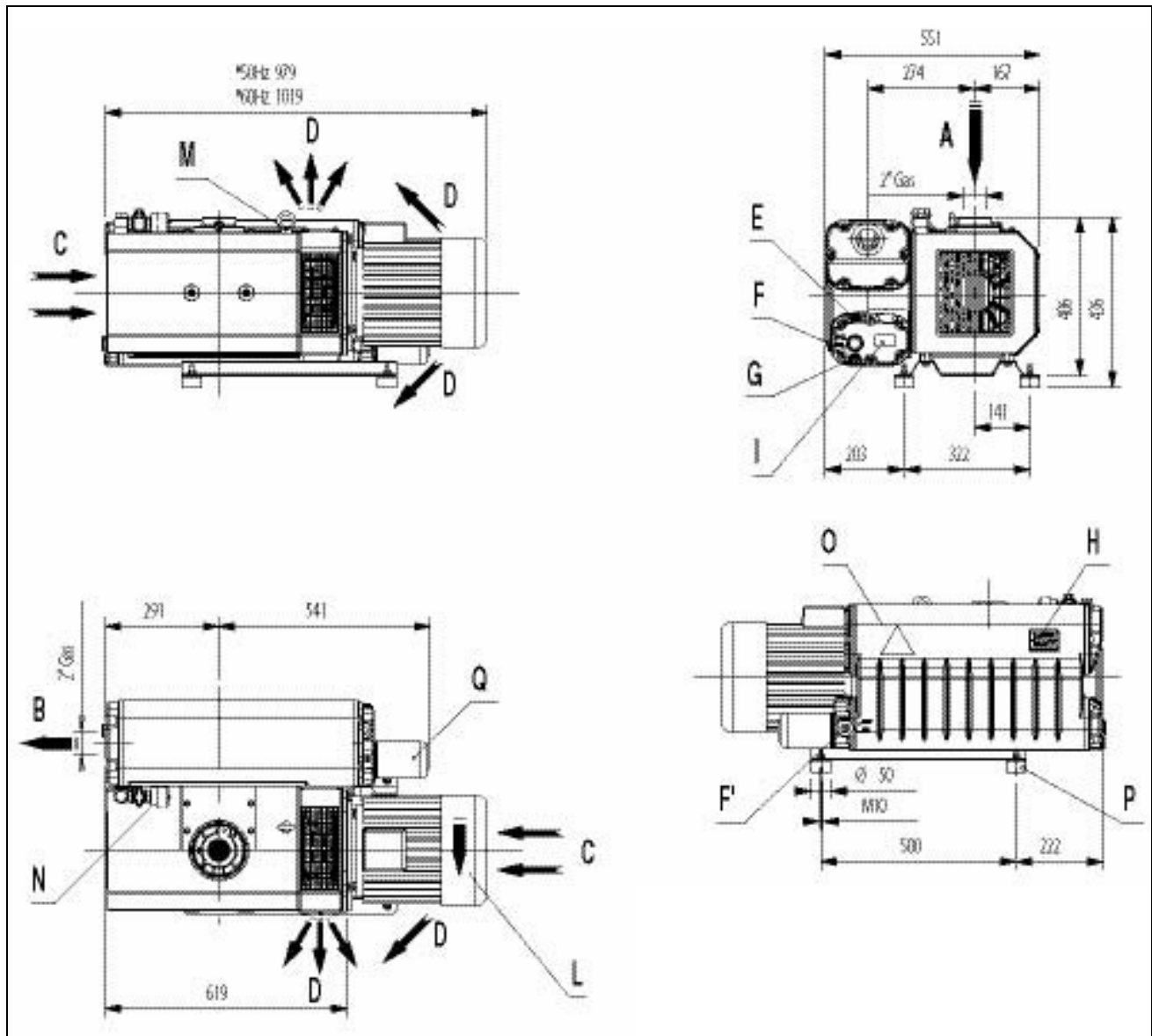

- Dimensions subject to changes (depending on motor brand)

Legend:

A	Inlet	H	Pump name plate
B	Exhaust	I	Oil grade label
C	Cooling air inlet	L	Rotation plate
D	Cooling air outlet	M	Lifting eyebolt
E	Oil filling plug	N	Gas ballast valve
F-F1	Oil sight glass	O	Oil filter
G	Oil drain plug	P	Vibration damper

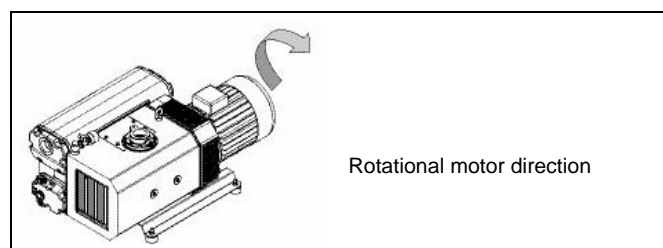

MS-301

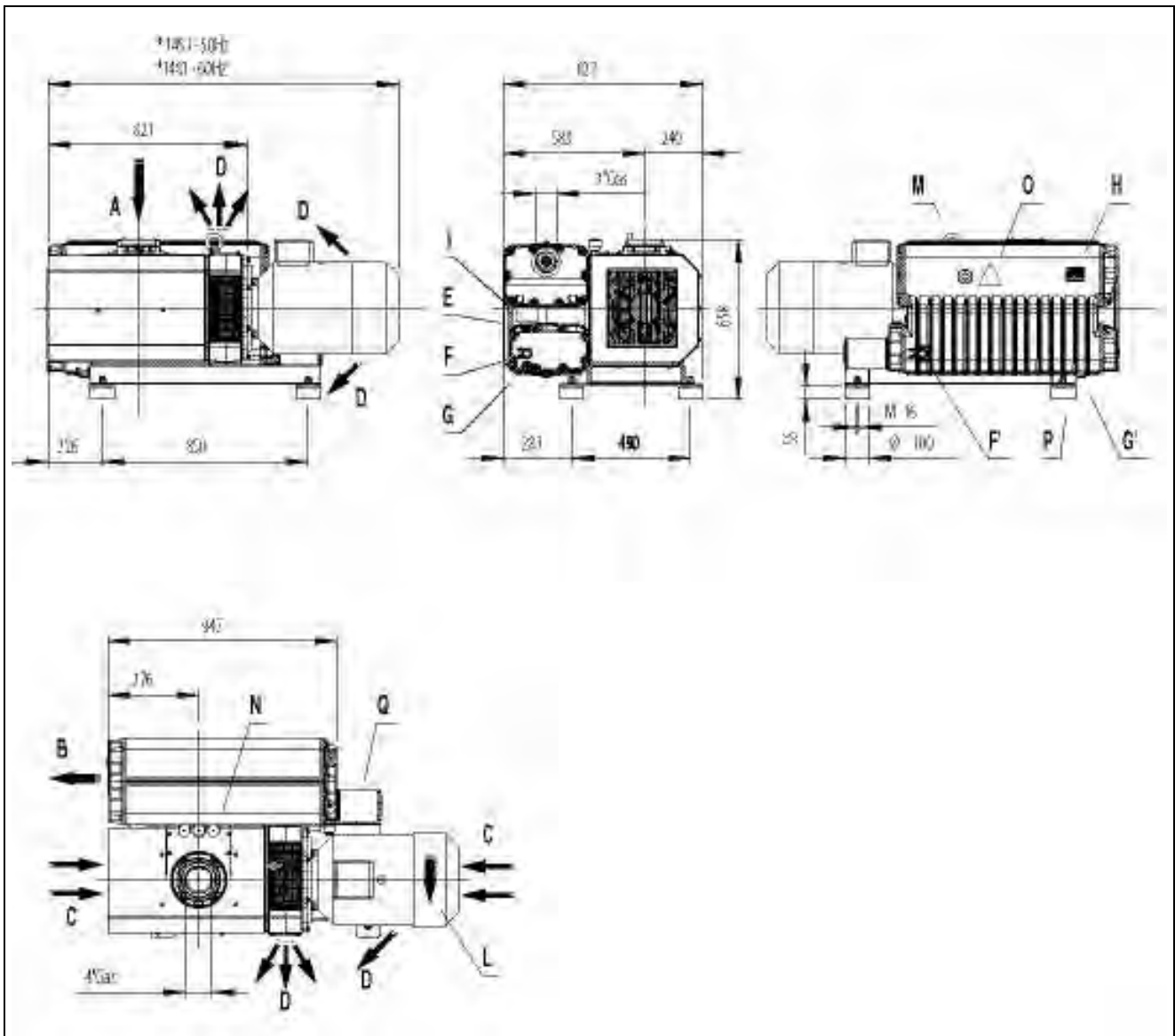

- Dimensions subject to changes (depending on motor brand)

Legend:

A	Inlet	I	Oil grade label
B	Exhaust	L	Rotation plate
C	Cooling air inlet	M	Lifting eyebolt
D	Cooling air outlet	N	Gas ballast valve
E	Oil filling plug	O	Hot surfaces name plate
F-F1	Oil sight glass	P	Vibration damper
G-G1	Oil drain plug	Q	Oil filter
H	Pump name plate		

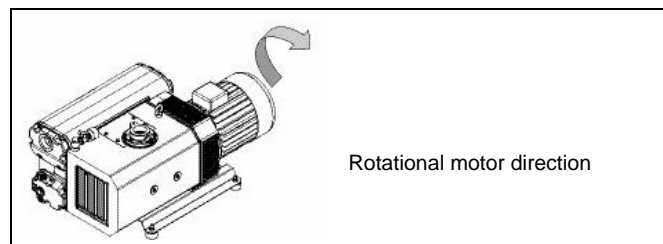

MS-631

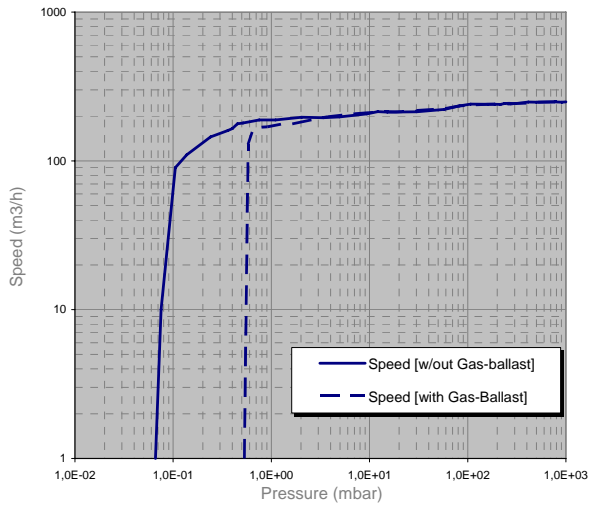

MS-301 Graph of delivery capacity vs inlet pressure with 50 Hz motor

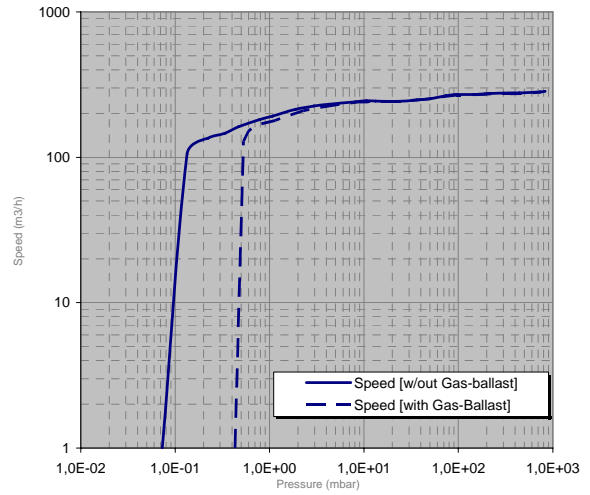

MS-301 Graph of delivery capacity vs inlet pressure with 60 Hz motor

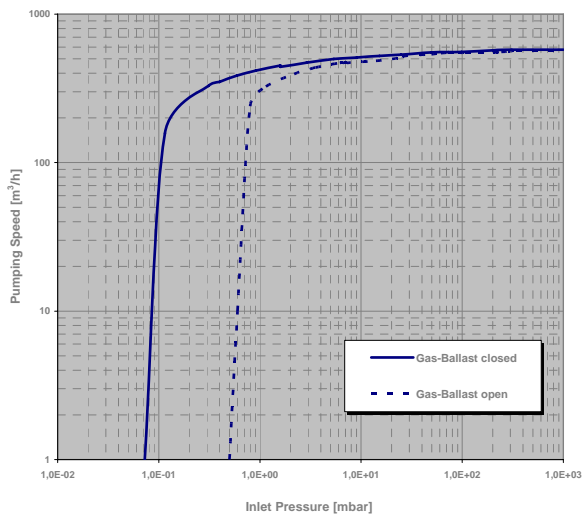

MS-631 Graph of delivery capacity vs inlet pressure with 50 Hz motor

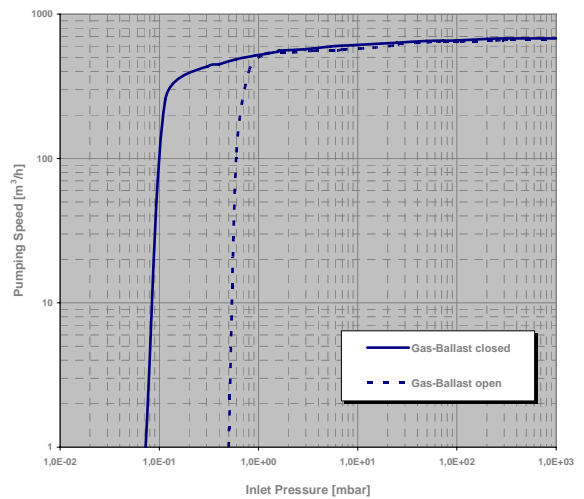

MS-631 Graph of delivery capacity vs inlet pressure with 60 Hz motor

— without gas ballast valve

- - - with gas ballast

SAFETY PRECAUTIONS

**CAUTION**

Despite of all the precautions adopted when designing the equipment, there are some risk elements that arise during operation and servicing.

**WARNING!**

The temperature of the pump surfaces may exceed 80 °C.

Install the pump in a protected area accessible only by authorized personnel, to prevent possible personal injuries due to contact with hot surfaces.

The pump can be placed inside other machines by adopting the necessary safeguards.

Before carrying out any maintenance on the pump, be sure the pump is cold.

**WARNING!**

The discharged air contains part of traces of oil mist. Check the compatibility with the environment. A failure of the seal wear can cause an oil leakage. Avoid the dispersion to the ground and the pollution of other materials. In case that any air containing dangerous substances must be pumped down (for example biological or microbiological agents), make sure to adopt filtering systems before introducing air in the work environment.

Used discharged oil from the pump must be disposed in accordance with the regulations in force in the Country of use.

**WARNING!**

Avoid any contact with the pump inlet port during the pump operation. Introduce air through the inlet port before every operation cycle.

Any contact with parts under vacuum can cause injuries.

**WARNING!**

The pump tank is pressurized. Do not open the oil filling and discharge plugs during operation.

**WARNING!**

All maintenance operations must be carried out with the pump idle, disconnected from the electrical supply, make sure to cold and vented to atmospheric pressure. Prevent unexpected start-up (e.g. block the power switch with a lock).

**WARNING!**

Some components of the electrical equipment are electrically charged during operation. Any contact may cause serious injuries to persons or objects.

Connections and controls of the electrical system must be carried out by skilled personnel only.

The electrical equipment must comply with the EN 60204-1 standard and with any other laws in force in the Country of use.

Besides, electrical equipment must comply with EN 61000-6-4 and EN 61000-6-2 standards concerning electromagnetic compatibility and electromagnetic immunity for industrial environment.

**WARNING!**

The use of the pump in situations unforeseen or not recommended by this manual, as well as lack of correct maintenance, may create high risks for overheating or fire.

In case of a fire do not use water to extinguish, but use a powder CO₂ extinguisher or other means compatible with the electric equipment and lubricating oil.

TRANSPORT AND HANDLING

Lifting

The orientation of the packed components must correspond to the instructions given by the pictograms on the external covering of the packaging.

For loading and unloading, use lifting equipment suitable for the pump weight. Use the suitable lifting eyebolts to lift the pump (see figure below).

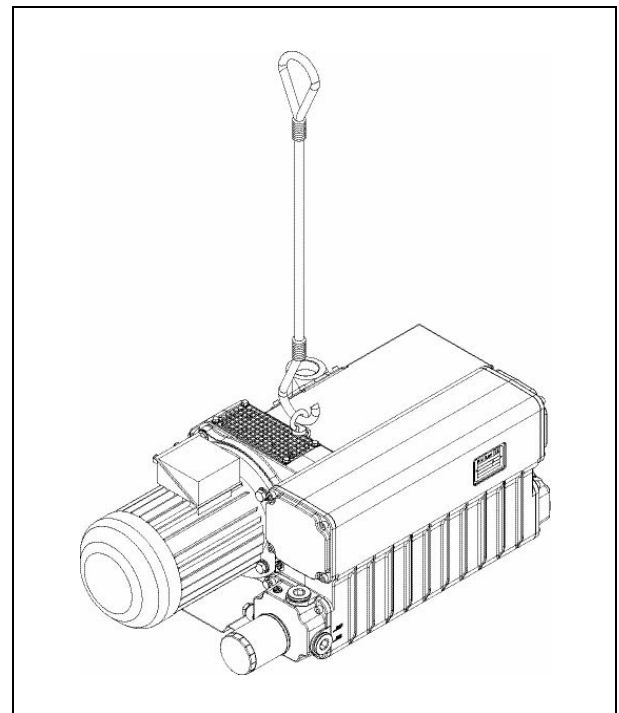

WEIGHT	UNITS	MS-301	MS-631
With 3 ph 50 Hz motor (approx. depending from motor mounted)	Kg (lb)	190 (418.50)	575 (1266.52)
With 3 ph 60 Hz motor (approx. depending from motor mounted)	Kg (lb)	192 (422.91)	612 (1348.02)
Without motor	Kg (lb)	140 (308.37)	385 (848.02)

Unpacking and components control

When receiving the pump check that the packaging is intact or shows any signs of damages occurred during transportation.

If there is no damage, proceed to the unpacking and check the pump further.

In case of damages are found, inform immediately Varian and the carrier. A representative will contact you or may be dispatched to the site to inspect and file full damage report.

Storage

The pumps must be stored or transported without any oil and protected from the atmospheric agents at;

- temperature: between -20° C and +70 °C
- humidity rate: 0 - 95% (non condensing)



CAUTION

Pay attention to perform all operation indicated in the following paragraphs before starting the pump, in order to prevent serious damages.

SECTION II

INSTALLATION AND OPERATION

Assembling

If the pump is supplied without any electrical motor, install a motor whose characteristics are the same as stated on the technical sheet, constructive form IM B5.



WARNING!

Check that the distance between the two coupling halves is:

- Type 1: $B = 3.5 \pm 1$ mm (see figure below)
- Type 2: $B = 3.5 \pm 1$ mm (see figure below).

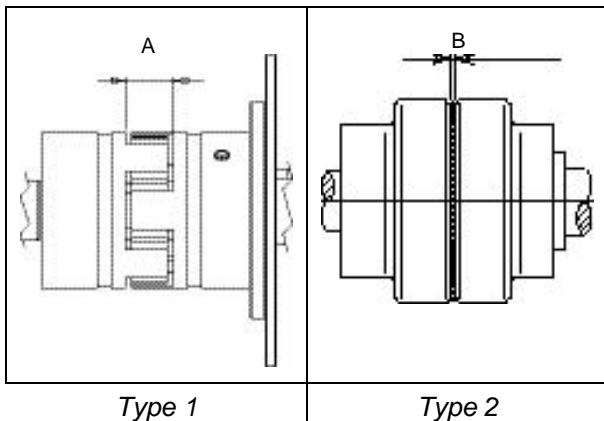

Gas Ballast

Pumps of the MS series are fitted with a gas ballast valve in order to exhaust any water vapour present in the rotor. When the pump operates with the gas ballast open, please follow these instructions:

- Position the selector switch in the flow direction (circuit is open).
- The ultimate pressure in this kind of operation is better than 0.7 mbar.

When water vapour has been removed and the pump original conditions are to be reset:

- Position the selector switch crossway with respect to the flow (circuit is closed)
- In this kind of operation the ultimate pressure is better than 0.1 mbar.

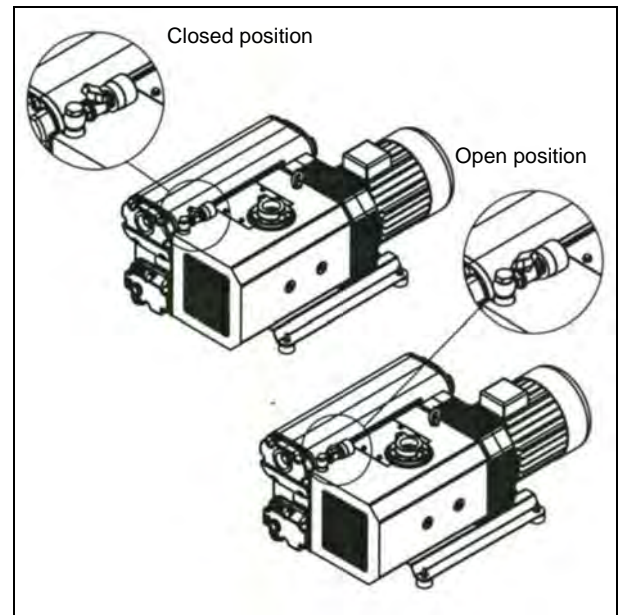

Positioning

- The pump must be installed in a protected area (see "SAFETY PRECAUTIONS").
- It must be fastened with support feet on horizontal surface.
- It must be accessible for correct and easy maintenance, by respecting the minimum distances from possible obstructions (see following figure and table).

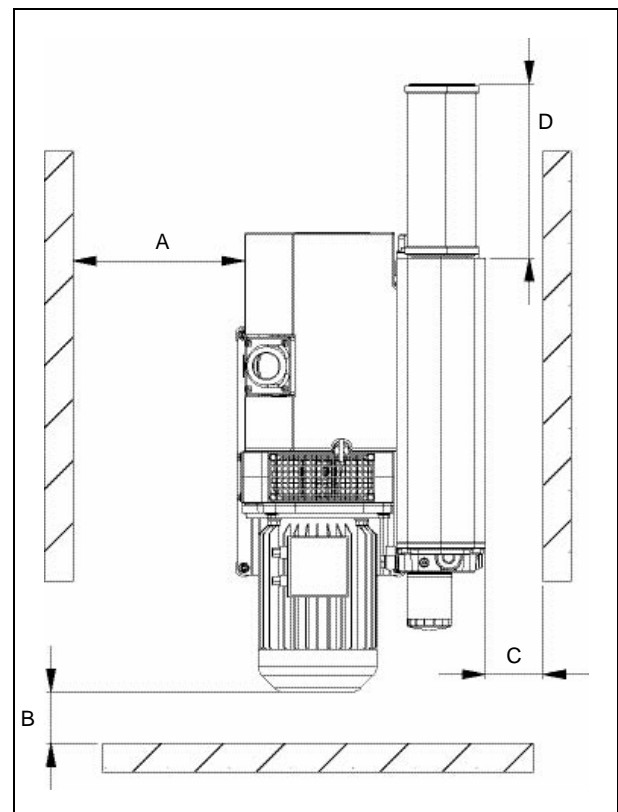

	A	B	C	D
MS-301	300 mm	300 mm	100 mm	350 mm
MS-631	500 mm	150 mm	100 mm	660 mm

- It must be accessible to suitable lifting equipment.
- Air change in the room or inside the machine where the pump has been installed must be ensured.
Avoid exceeding 40 °C ambient temperature.
- The pump must be protected against jets or sprays of water that may penetrate the tank through the exhaust port.
- Whenever the pump is installed outside, it must be protected against atmospheric agents.

**WARNING!**

Do not install the pump in a dusty area or where other materials may block or quickly cover the cooling surfaces.

CONNECTIONS TO THE INLET AND EXHAUST FLANGES

Remove the protective caps from both flanges. Connect the system to be evacuated to the inlet flange, using a centering ring with OR and a locking collar.

NOTE

For guaranteed reliable sealing, use an OR gasket in Perbunan or Viton.

The inlet duct is equipped with a sieve filter preventing solid particles from entering and damaging the pump.

NOTE

When the gases to be pumped out contain dust, it is advisable to insert a dust filter before the inlet flange.

NOTE

When the gases to be pumped out contain large quantities of vapor, it is advisable to include a condense separator before the inlet flange.

To make best use of the pump's capacity, use only short, straight piping, with a diameter not smaller than that of the inlet flange.

NOTE

If rigid piping is used, it is good practice to use a flexible joint in order to avoid undue forcing of the connection on the pump.

The exhaust duct must be connected to a pipe that will take away the pumped out gases.

NOTE

Application of an oil trap filter is necessary to avoid pollution of the surrounding atmosphere by the oil present in the exhaust duct during pump operation.

**CAUTION**

Never block the pump exhaust line. This would cause overpressure in the casing with the risk of breaking the glass window of the level indicator and/or expelling the oil seal gasket.

**CAUTION**

For proper operation, the filter (optional) must be mounted in HORIZONTAL position.

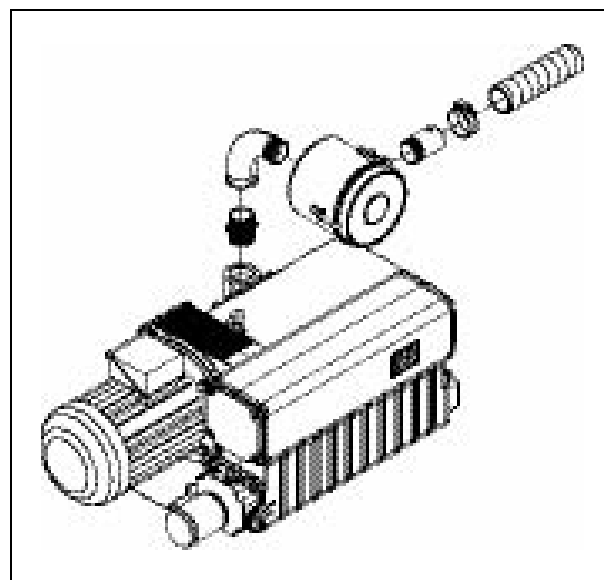
**Connection to the vacuum system**

The connection to the chamber to be pumped down must be carried out by means of pipes of the same diameter as the inlet port.

Pipe weights and expansions, if any, must not rest on the pump.

It is advisable to make the final connection to the pump with flexible pipes or fittings.

It is important that all the pipes and the different fittings are tight and, if possible, check with a Varian leak detector. Very long or small diameter pipes will decrease the pump performances.

Discharge air pipe line installation

- When required, it is possible to pipe the pump discharge air to other rooms, or outside.
- Use pipes with the same diameter as the tank discharge port with a maximum length of 15 m. For longer pipes increase pipe diameter. Pipe weights must not rest on the pump. In the final length use flexible pipes or pipe fittings.



WARNING!

This pipe must be descending, to avoid the condensate going back to the tank.



CAUTION

Do not connect ball valves to this pipeline.

Electrical connection



WARNING!

The control panel and electrical connections must be carried out by skilled personnel and conform to the EN 62204-1 rules or any other local regulations in the country of use.



CAUTION

The electrical equipment must comply with EN 61000-6-4 and 61000-6-2 standards concerning electromagnetic compatibility, emission standard and immunity for industrial environments.

Check the main voltage and frequency in use to correspond to the data stamped on the motor name plate.

The electrical motor must be protected against overload. The full amperage on the motor name plate must be considered when sizing the electrical components and motor protection against overloading.

Make sure the grounding is correctly done.

Carry out the electric connection following the diagram shown on the motor terminal box.

Check direction of rotation by starting the pump for a short time (2 or 3 seconds). The correct direction is shown by the arrow on the pump (see figure below). In case of wrong rotation, it is necessary to change the motor rotation by exchanging position of two of the three connections in the motor terminal box.

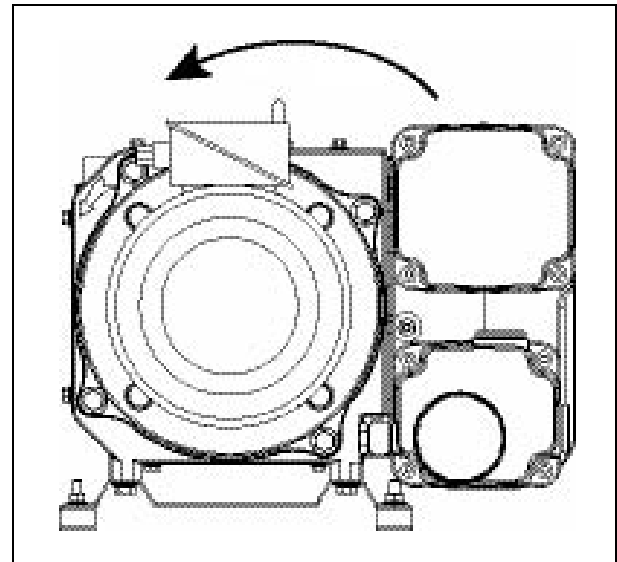

WARNING!

The pump is supplied without lubricating oil.



CAUTION

The operation without oil causes big damages to the pump.

Carry out the first oil filling through the plug (E) up to the half of the sight glass (F) and close the plug (E) (see following figure).

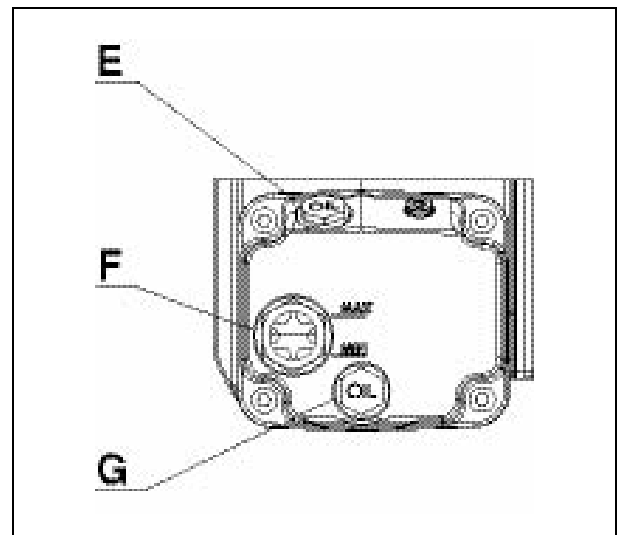

Oil change parts identification

Start the pump and let it run at least 2 minutes.

Stop the pump, check again the oil level and add some additional oil, if necessary, in order to get the correct oil level.

Suggestions for use

When the room temperature is lower than 10 °C, it is a good practice to let the pump operate (at maximum vacuum level) for about 5 minutes. During this period the pump may not reach the stated pressure limits.

**CAUTION**

Avoid operating the pump for long periods with inlet port vented to atmospheric pressure. This will cause a heavy oil loss.

**CAUTION**

Avoid frequent stop-start cycles, as this will lead to premature coupling elastic element wear. It is advisable not to exceed 10 cycles/hour. For more frequent cycles, it is recommended to install a progressive starter (soft starter) or a star/delta starter. When using a star/delta starter, the vacuum pump can start exclusively with the inlet vented to atmospheric pressure.

Water vapour suction

In order to pump down any water vapour, it is essential to bring the pump temperature to its operating value. In case there are other condensates in the oil, let the pump run for at least thirty minutes with the gas ballast valves in position "open", at the end of the working cycle.

It is advisable to carry out this operation before stopping the pump for a long time. The gas ballast valve will allow the elimination of water condensate from lubricating oil.

NOTE

For repetitive work cycles, with brief time intervals in between, it is better not to stop the pump.

STOPPING THE PUMP

There are no special procedures for switching the pump off; it needs only to be disconnected from the electric power.

When the pump is stopped, the anti-suckback device makes it possible to maintain vacuum in the vessel connected on the inlet flange of the pump.

If the pump is expected to be stopped for a lengthy period, or in any case if it has pumped in large amounts of vapors, it is good practice to run it with the gas ballast open and the inlet line closed for a few minutes before switching off in order to limit the risk of corrosion or scaling due to pollution of the oil by condensed vapors.

SAFETY RULES

Personnel responsible for pump operation and maintenance must be well-trained and must be aware of the accident prevention rules.

The accident prevention precautions contained in this section must be respected at all times during operation and maintenance of the pump to avoid damage to operators and to the pump.

These precautions are provided in the form of WARNING and CAUTION notes.

**WARNING!**

Operating procedures, technical information and precautions which, if not respected and/or implemented correctly may cause body harm to operators.

**CAUTION**

Operating procedures, technical information and precautions, which, if not respected and/or implemented correctly, may cause damage to the pump.

WARNING NOTES

- a. Death may result from contact with high voltages. Always take extreme care and observe the accident prevention regulations in force.
- b. Always disconnect the power supply to the pump before maintenance work. Place a special warning signs over the power supply breaker switch: MACHINE UNDERGOING MAINTENANCE - DO NOT POWER ON.
- c. If you are performing maintenance after the pump has been operating for a considerable time, allow sufficient time for it to cool as the external surface temperature may be in excess of 80°C.
- d. Failure to provide the pump with an earth connection may cause serious damage to operators. Always ensure that there is an earth connection and that it complies with the standards.
- e. When cleaning the pump and its component parts, avoid the use of flammable or toxic solvents, such as benzin, benzol, ether or alcohol. The recommendation is to use a soap and water solution, preferably in ultrasound washing machines, taking care to dry all the cleaned parts at temperatures under 100 °C in order to eliminate residual moisture.
- f. Prolonged overloads or breakdowns may cause the electric motor to overheat, and to release noxious smoke; remove the power immediately as a precaution and do not ap-

proach the pump at least until you have provided ventilation to drive out the smoke. Take care not to breathe in the fumes remaining inside the pump in the course of repair work.

- g. In case of fire, do not throw water on the pump. Switch the power off and use CO₂ extinguishers.
- h. Carefully inspect the flanges to ensure that there is no dust, oil, dirt or defects of the mating surfaces, before making the required connections.
- i. Ensure that all joints and couplings are locked correctly before starting the pump again after repair work.
- j. Do not wear any objects that may become entangled in the mechanisms and/or act as conductors (chains, bracelets, etc.).
- k. Ensure that the tools to be used are in perfect working condition and have insulating grips, where necessary. Check that the insulating material of the cables and that the conductors of the test equipment do not show any signs of damage.
- l. Do not replace the oil immediately after stopping the machine as the oil may still be at high temperature.
- m. Perform repairs in clean and, where possible, dust-free areas. Protect all the clearances of connection points with suitable plastic caps and cover the machined surface areas of all parts stripped down until they are put back on the pump again.
- n. Do not start the pump if the fan cover sleeve (reference 81 of fig. MS-301 Pump parts – Exploded View and 82 of fig. MS-631 Pump parts – Exploded View) is not properly in place.

CAUTION NOTES

- a. Before putting the pump back into operation after a breakdown, inspect it and check carefully for any other signs of damage.
- b. Use only tools that are in perfect working order and specially designed for the job; use of inappropriate or ineffective tools may cause serious damage.
- c. Perform repairs in clean and, where possible, dust-free areas. Protect all the clearances of connection points with suitable plastic caps and cover the machined surface areas of all parts stripped down until they are put back on the pump again.
- d. Always check the lubricant and that it is properly distributed through the pump; inadequate lubrication may damage the pump seriously.

- e. Give the parts some form of marking as you strip them down to ensure that you reassemble them again in the proper order.
- f. Check that there are no scratches or grooves on the machined shafts, in their seats inside the pump or on machine-ground surfaces. Slight scratches and abrasions may be eliminated with very fine emery paper or by a little light grinding.
- g. Before putting a group together, always spread a little oil over inner parts and mating surfaces. Replace all seals with original spare parts before reassembling components.

MAINTENANCE ACTIONS

Maintenance may be seen as the totality of all scheduled and unscheduled maintenance work.

Maintenance includes:

1. **SCHEDULED MAINTENANCE:** Maintaining the nominal state of operation.
2. **UNSCHEDULED MAINTENANCE:** Restoring the nominal state of operation

NOTE

The frequency with which repairs are performed depends on the process and presence of substances that shorten pump life (dust, abrasives, solvents, water, chemically aggressive substances).

The pump must be cleaned at regular intervals of time.

CAUTION

Do not clean with Alcohol the plastic or rubber components of the pump.

Use only the strictly necessary amount of lubricant; an excess of lubricating oil, like when there is none, may sometimes compromise proper operation of the pump.

Only the recommended lubricants, or lubricating oils with similar characteristics and known and experimented quality, should be used.

Oil changes must be made with the oil at a sufficiently high temperature, after leaving the pump to cool for a few minutes following operation.

The drain and filler plugs must not be left open any longer than is strictly necessary.

When performing maintenance, look out for all signals that may precede a breakdown, in particular:

- traces of corrosion;
- oil leaks;

- slack joints or couplings.

Maintenance technicians must:

- be aware of all applicable national directives concerning accident prevention during work on motor-driven pumps and should know how to apply them;
- have read and understood all the sections on "Safety Rules";
- be familiar with the essential design features and operation of the pump;
- know how to use and consult the pump documentation;
- be concerned about proper operation of the pump;
- make a note of any irregularities in operation of the pump and take the necessary action, where appropriate.

Use original spare parts wherever possible and repair a broken part as best as possible on site or send it back to the manufacturer for repairs.

For all problems arising, or to order spare parts, refer to our service department.

LUBRICANTS

It will be readily understood how important adequate lubrication is to high technology pumps like the Varian vacuum pumps. Correct use of appropriate lubricants makes a significant contribution to achieving best performance and warding off defects.

When handling lubricants, the following sanitary protection measures should be observed at all times:

- Avoid prolonged, excessive or repeated contact of the skin with products for lubrication, and also avoid directly inhaling the fumes or vapors of such products.
- Protect the skin by wearing appropriate clothes and equipment (e.g. special suits, glasses or, where permitted by the safety regulations, gloves) or by applying a special protective product.
- Clean the skin carefully after contact with the lubricants by washing freely with water and soap.
- Apply a skin cream after washing.

- Take off and change clothes or shoes on which oil has been spilled.
- Never put rags dripping with oil into the pockets of your clothes.

When disposing of waste lubricants, observe the following environment protection regulations:

- The lubricants risk contaminating the water and the ground! Therefore never pour lubricating products on to the ground, into water or in the sewage system. All violations of these rules are liable to persecution as provided for by law. When using lubricants always keep oil can nearby.
- Take care in draining off waste oils. In disposal of these products respect all regulations in force concerning waste oil disposal.

The recommended lubricating oil is the Varian Rotary Vane Fluid MS1 Type. The Rotary Vane Fluid MS1 Type is a general purpose mechanical pump fluid specifically engineered to provide superior performance in high speed direct drive mechanical pumps.

These precisely distilled fluids (100% solvent refined neutral paraffinic oil) deliver lower base pressure capability, faster pump-down cycles, and reduced maintenance requirements on both the pump and the fluid.

It is absolutely necessary to continue using the lubricants initially used to fill the tank. If this is not possible for organizational or business reasons, use only products with the same characteristics as the previous oils.

Only use of lubricants of suitable quality will guarantee safe operation of the pumps.

CAUTION

Mineral oils and the PFPE oil are incompatible. To change from one type to another, the pump must be stripped down completely and all parts washed carefully to eliminate all oil residues.

If you expect to have to use other lubricants, first find out if the two products are compatible. In cases of doubt, the lubricant used up to that time must be flushed out by way of a pump flushing procedure.

CAUTION

To avoid the risk of contaminating the oil, absolute cleanliness of the pump and surrounding area must be ensured during the lubrication procedures.

Pumps must be filled with MS-1 Varian oil only.

Ambient temperature	Grade	Varian oil
+12 – 40 °C	ISO 68	MS-1

Recommended oil

For ambient temperature outside the stated range, please get in touch with our Customer Service department.

*Varian Rotary Vane Fluid MS-1 Type
characteristics*

Property	Unit of measure	Rotary Vane Fluid MS-1 type
Vapour pressure @ 38 °C	Torr	$8.4 \cdot 10^{-12}$
Vapour pressure @ 66 °C	Torr	$8.3 \cdot 10^{-9}$
Vapour pressure @ 93 °C	Torr	$1.0 \cdot 10^{-6}$
Viscosity @ 40 °C (DIN 51550)	cSt	98.32
Viscosity @ 100 °C (DIN 51550)	cSt	2.41
Viscosity index (ASTM D2270)		202
Density @ 15 °C	g/ml	0.865
Pour point (DIN ISO 3016)	°C (°F)	-48 (-118.4)
Flash point C.O.C. (DIN 51376)	°C (°F)	271 (519.8)
Coefficient of Thermal Expansion:	1/°F	0.00041
Specific Heat @ 38°C	BTU/lb°F	0.51
Specific Heat @ 66°C	BTU/lb°F	0.53
Specific Heat @ 93°C	BTU/lb°F	0.56
Thermal Conductivity @ 38°C	BTU/hr ft ²	0.092
Thermal Conductivity @ 66°C	BTU/hr ft ²	0.091
Thermal Conductivity @ 93°C	BTU/hr ft ²	0.090

SECTION III**SERVICING****General information**

Before every maintenance operation:

- Ensure that the pump motor is disconnected from the electrical network so that it can't automatically start.
- Make sure the pump has reached an ambient temperature.
- Introduce air in the inlet port.

In order to keep the pump operating at a high efficiency level, it is mandatory to follow all periodical service points listed in the table below. However, more frequent service operations may be necessary depending on what the pump is used for (suction of condensable vapours, suction of powders or polluting substances). For such cases, only direct experience can indicate the correct service frequency needed. Please contact Varian Technical Support for further details. The exhausted oil and replaced spare parts must be considered as special waste products and handled according to the local regulations in the country of use.

SERVICE FREQUENCY	DESCRIPTION OF THE OPERATION	AUTHORIZED PERSONNEL
24 hours/every day	Check oil level before starting	Operator
100 hours/every week	Clean the external inlet element with a blast of air (refer to "Pumps Major Parts" figure, position A)	Operator
	Clean the cooling surfaces of the pump, of oil cooler and the electrical motor with a blast of air	
2000 hours/every 6 months	Replace the lubricating oil and oil filter (refer to "Pumps major parts" figure, position C). Doesn't use car air filter but with anti suck back valve. See "Oil change procedure" at page 40	Skilled worker
	Clean the float valve. See "Float valve cleaning procedure" at page 41	
	If the pressure gauge is fitted to the pump, check the oil separator (max 0.6 bar); if necessary, replace it. See "Oil separator change procedure" at page 41	
	Replace the gas ballast felt disk (refer to "Pumps major parts" figure, position E. See "Gas ballast felt disk change procedure" procedure at page 41	Skilled worker
	Replace the exhaust filter (refer to "Pumps major parts" figure, position B). See "Exhaust filters replacement procedure" at page 41	
	Check and if necessary replace the coupling elastic insert (refer to "Pumps major parts" figure, position D). See "Coupling elastic element replacement procedure" procedure at page 41	
	Check the electrical connections	
8000 hours/every 2 years	Grease the electrical motor bearings	VARIAN service
30,000 hours/every 5 years	Pump overhaul	VARIAN service or Skilled worker

- The first oil change has to be done after 500 hours of operation. Next oil change must be done within 2000 hours.

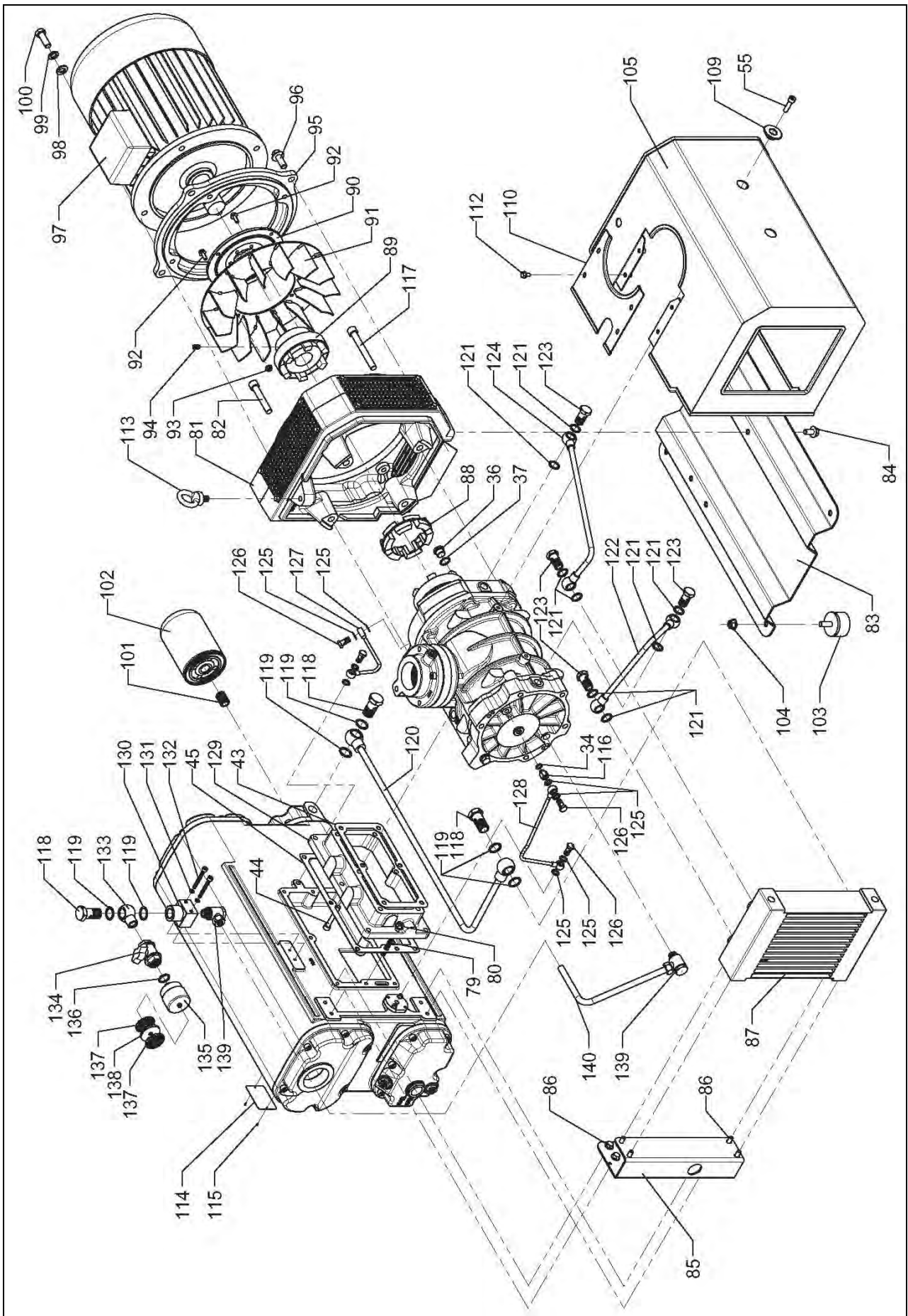

MS-301 Pump parts – Exploded View (1 of 2)

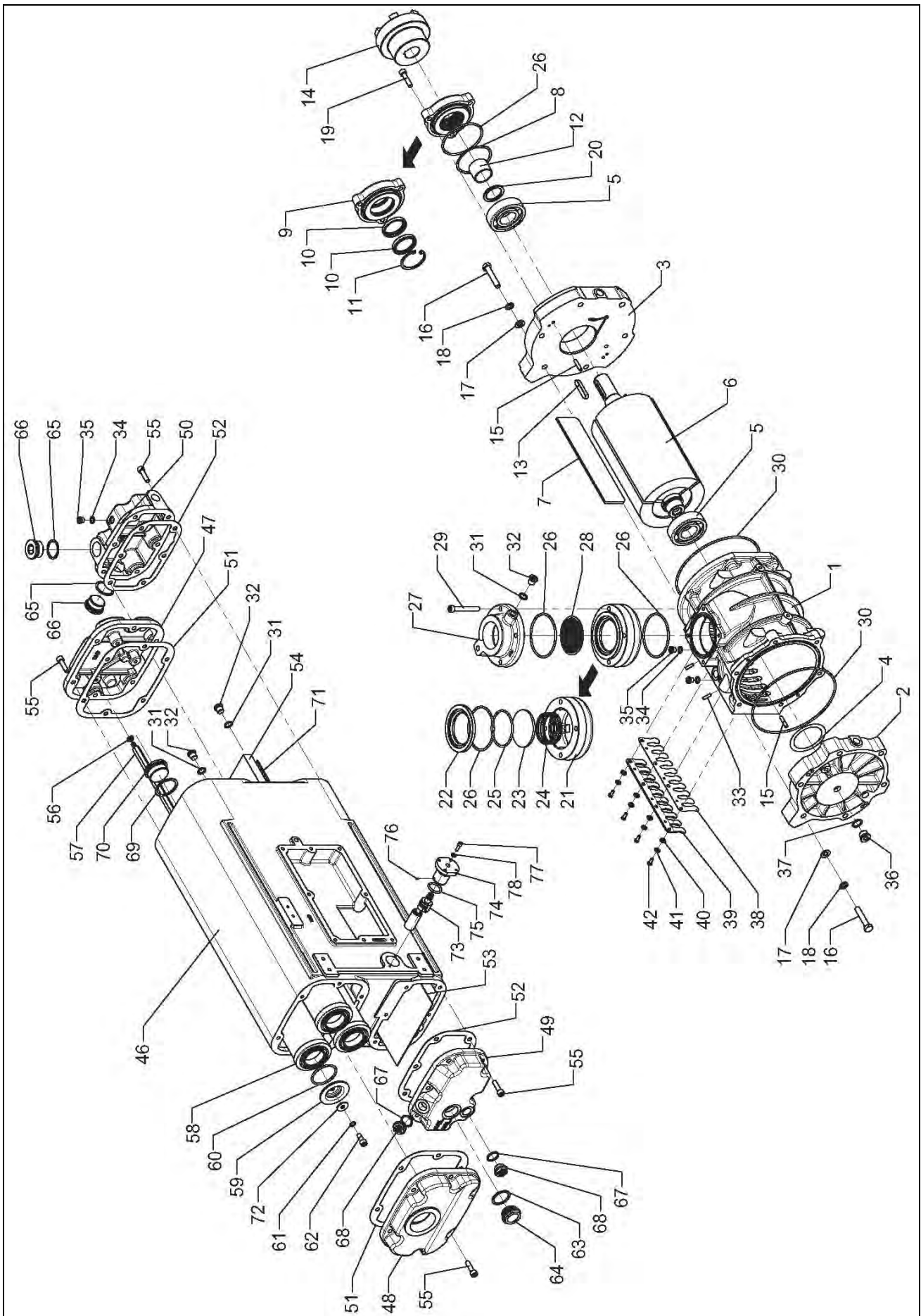

MS-301 Pump parts – Exploded View (2 of 2)

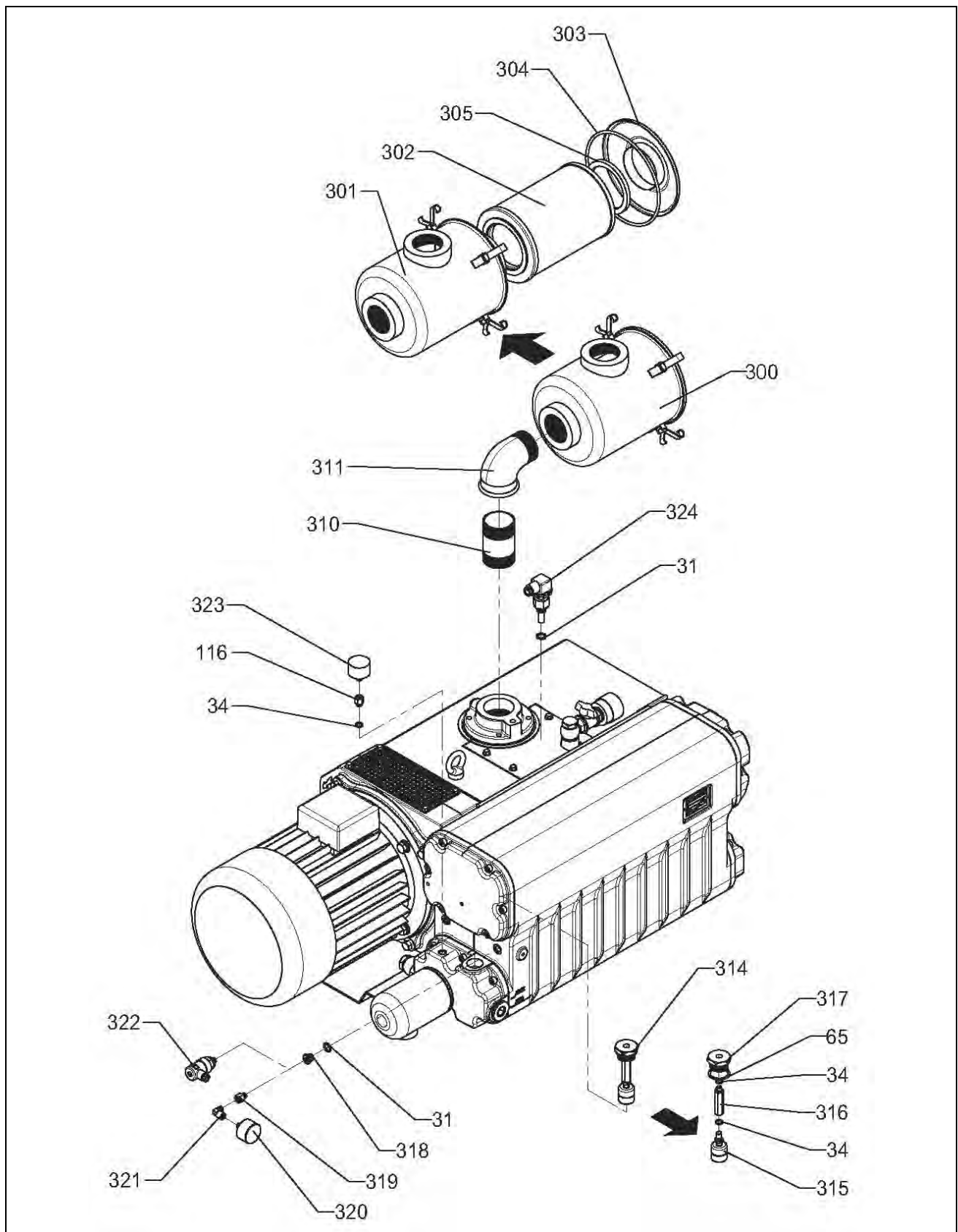

MS-301 Pump accessories – Exploded View

Pump Parts for MS-301

POS.	SPARE PARTS P/N	DESCRIPTION	Q.TY
1		Body of pump	1
2		External side cover	1
3		Motor side cover	1
4		63x80 Space washer	1
5	(B)	6307 Bearing	2
6		Rotor	1
7	(B)	Vane	3
8		Shim ring	1
9		Oil seal ring cover	1
10	(B)	BABSL 40x52x7 Seal ring	2
11		l53 Seeger	1
12	(B)	IR 35X43X30 Ring	1
13		10x8x50 Key	1
14	SR03705716	Pump side coupling half	1
15		Ø6x30 Pin	4
16		M10x55 Partially threaded Hex. Screw	11
17		Ø10 Washer	11
18		Ø10 Lock washer	11
19		M8x35 Hex. Socket head screw	3
20		Ø35/45x3 Spacer	1
21		Inlet valve body	1
22		Inlet valve disk	1
23	(C)	Inlet valve plate	1
24	(C)	Helicoidally spring	1
25	(C)	O Ring 173	1
26	(C)	O Ring 4337	4
27		2"G Inlet flange	1
28		Inlet filtering baffle	1
29		M8x65 Hex. Socket head screw	4
30	(B)	O Ring 4725	2
31		1/4"G Al washer	3
32		1/4" Al Hex. Socket head plug	3
33		Ø2mm Adapter	2
34		1/8"G Al washer	4
35		1/8"G Hex. Socket head plug	3
36		3/8"G Hex. Socket head plug	2
37		3/8"G Al washer	2
38	(B)	Plate (thickness = 0,25)	1
39		Plate support	1
40		Ø6 Washer	4
41		Ø6 Lock washer	4
42		M6x12 Hex. Screw	4
43	(B)	Body of pump-spacer gasket	1

POS.	SPARE PARTS P/N	DESCRIPTION	Q.TY
44		M8x55 Hex. Socket head screw	6
45	(B)	Spacer-tank gasket	1
46		Tank	1
47		Motor side upper tank cover	1
48		External side upper tank cover	1
49		External side lower tank cover	1
50		Motor side lower tank cover	1
51	(A) (B)	Gasket for upper tank covers	2
52	(B)	Gasket for lower tank covers	2
53		Tank micro-stretched sheet	1
54		192x122x20 tank demister	1
55		M8x30 Hex. Socket head screw	26
56		Ø8 Lock washer	3
57		Stay bolt for exhaust filter	3
58	(A) (B)	Exhaust filter	3
59		Disk for exhaust filter	3
60	(A) (B)	O Ring 4200	6
61		Ø8.4/13x1 Al washer	3
62		M8x20 Hex. Socket head screw	3
63		1"G Fiber washer	1
64		1"G Oil sight glass	1
65		1"G Al washer	2
66		1"G Hex. Socket head plug	2
67		1/2"G Fiber washer	2
68		1/2"G Filling-discharge plug	2
69		1" 1/4G Al washer	1
70		1" 1/4G Hex. Socket head plug	1
71		Demister-tank support mesh	1
72		Ø8/24 Washer	3
73	(B)	Float (oil recovery)	1
74		Float port	1
75	(B)	O Ring 4093	1
76		M4x8 Hex. Socket Stud Bolt	1
77		M5x16 Hex. Socket head screw	2
78		Ø5 Washer	2
79		M8x30 Stud bolt	8
80		M8 Nut (flanged and knurled)	8
81		Fan cover sleeve	1
82		M12x70 Hex. Socket head screw	3
83		Base-plate	1
84		M10x20 Hex. Screw (flanged and knurled)	4
85		Oil cooler support	1
86		M8x16 Hex. Screw (flanged	8

POS.	SPARE PARTS P/N	DESCRIPTION	Q.TY
		and knurled)	
87		Air/oil cooler	1
88	SR03705719	Elastic coupling insert	1
89	SR03705718	Motor side coupling half	1
90		Fan hub	1
91		Ø280x73 Fan	1
92		M6x16 Hex. Screw (flanged and knurled)	10
93		M6 Nut (flanged and knurled)	4
94		M8x16 Hex. Socket Stud Bolt	1
95		Motor flange	1
96		M12x30 Hex. Screw flanged and knurled	4
97A	SR03705592	Electric motor M132 B5 4P 5.5kW 50Hz	1
97B	SR03705721	Electric motor M132 B5 4P 7.5kW 60Hz	1
98		Ø12 Washer	4
99		Ø12 Lock washer	4
100		M12x35 Hex. Screw	4
101		UNF 3/4"-16 Nipple	1
102		Oil filter	1
103		Ø50x30 M10x27 Vibration-damping foot	4
104		M10 Nut (flanged and knurled)	4
105		Casing	1
109		Disk (for casing)	2
110		Casing cover	1
112		Hex. (Screw flanged and knurled)	4
113		M12 Eyebolt	1
114		Pump name plate	1
115		Ø1.85x5 Rivet	2
116		A5/Z M-F 1/8"-1/8" Extension	1
117		M12x100 Hex. Socket head screw	1
118		Screw for 1/2"G fittings	3
119		1/2"G Cu Washer	6
120		Oil cooler inlet pipe	1
121		3/8"G Cu Washer	8
122		Oil pipe (external side)	1
123		Screw for 3/8"G fittings	4
124		Oil pipe (motor side)	1
125		1/8"G Cu Washer	8
126		Screw for 1/8"G fittings	4
127		Oil pipe (outlet seal rings)	1
128		Oil recovery pipe (H-series)	1
129		Pump-tank spacer	1
130		Gas ballast support	1
131		Ø6 Lock washer	2

POS.	SPARE PARTS P/N	DESCRIPTION	Q.TY
132		M6x50 Hex. Socket head screw	2
133		1/2"G Banjo male	1
134		1/2"G F-F Ball valve	1
135		1/2"G Gas ballast valve	1
136		O Ring 3075	1
137		Micro-stretched sheet disk	2
138		Ø42/8x4 Felt disk	1
139		3/8" G Banjo coupling with allow screw	2
140		Gas ballast pipe (H-series)	1

POS.	SPARE PARTS P/N	OPTIONALS	MS301
31		1/4"G Al washer	2
34		1/8"G Al washer	3
65		1"G Al washer	1
116		A5/Z M-F 1/8"-1/8" Extension	1
300		Inlet filter F300 (complete)	1
301		Filter housing	1
302		Filter element	1
303		Filter cover	1
304		O Ring M. Ø185 c=5	1
305		V Gasket	2
310		M M 2"G Pipe fitting	1
311		A4 2"G Elbow union	1
314		Oil level switch (complete)	1
315		Oil level switch	1
316		Oil level switch extension	1
317		Oil level switch port	1
318		A4/Z M-F 1/4"-1/8" Adapter	1
319		A5 M-F 1/8"-1/8" extension	1
320		PVR pressure gauge	1
321		A10 M-F 1/8"-1/8" fitting	1
322		Adjustable pressure switch	1
323		Oil filter condition indicator	1
324		Safety temperature switch	1

NOTES

- (A) Part of MS-301 Minor Maintenance Kit (P/N 949-5020)
- (B) Part of MS-301 Major Maintenance Kit (P/N 949-5021)
- (C) Part of MS-301 Inlet Valve Kit (P/N SR03705715)

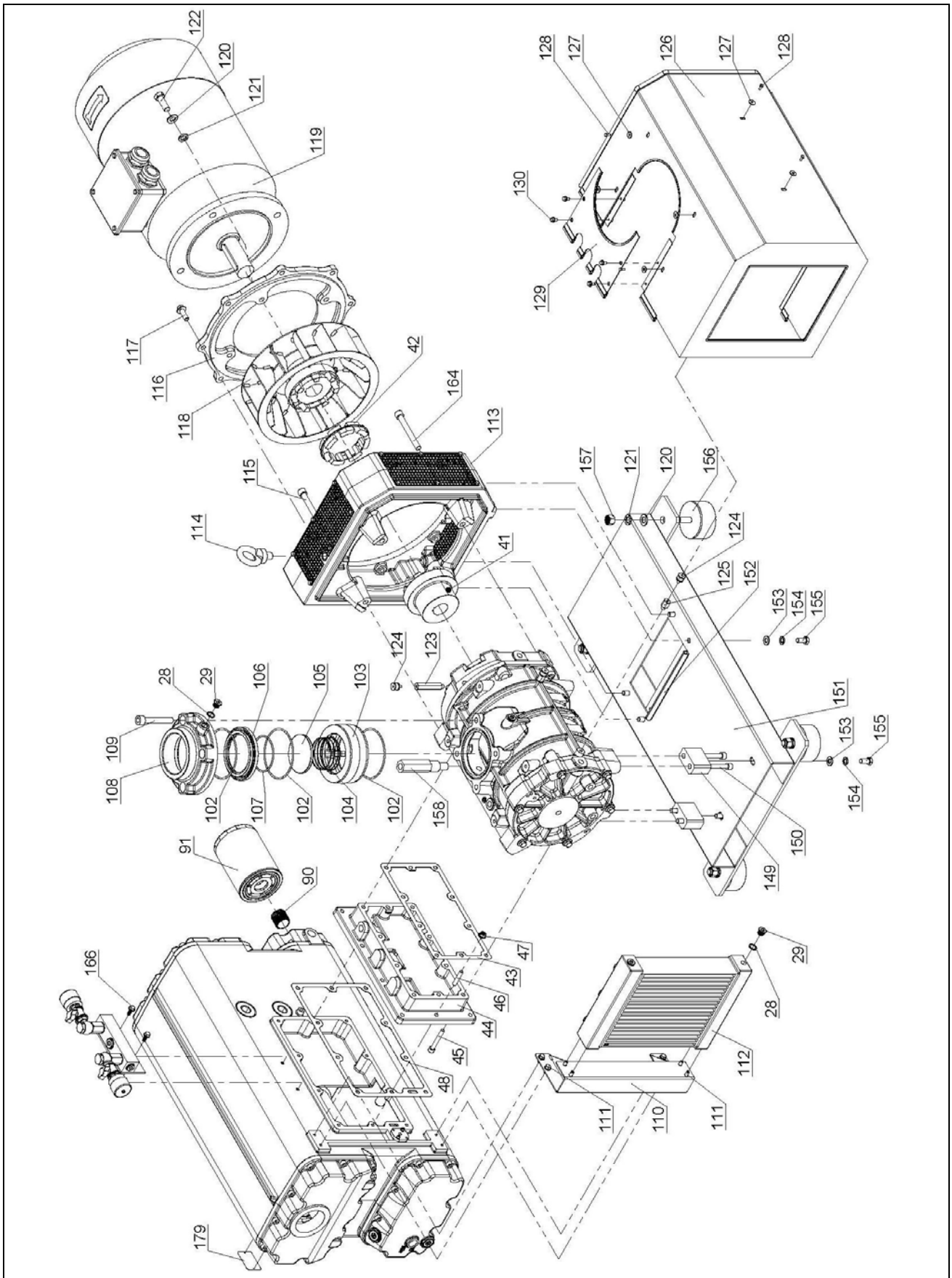

MS-631 Pump parts – Exploded View (1 of 4)

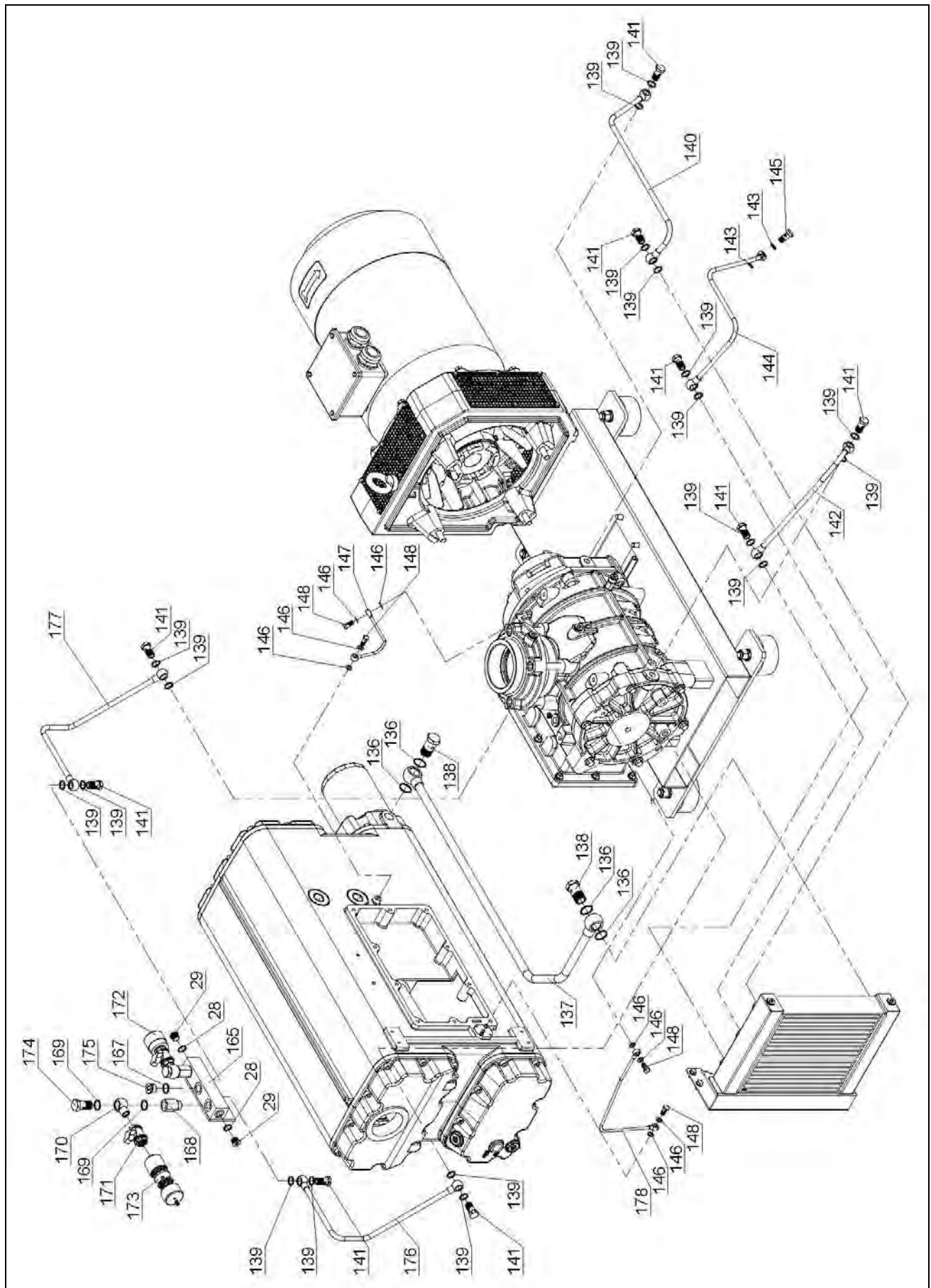

MS-631 Pump parts – Exploded View (2 of 4)

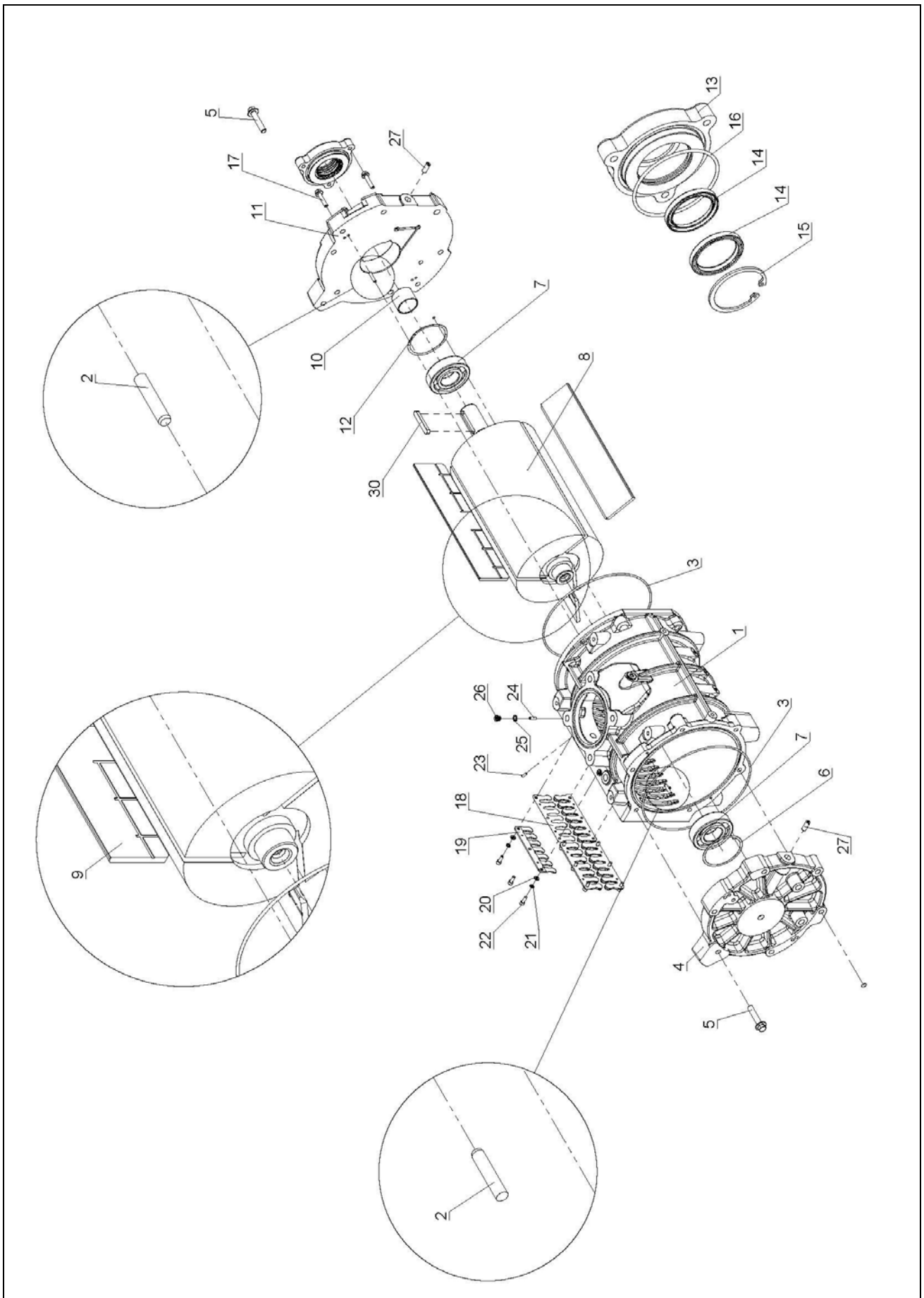

MS-631 Pump parts – Exploded View (3 of 4)

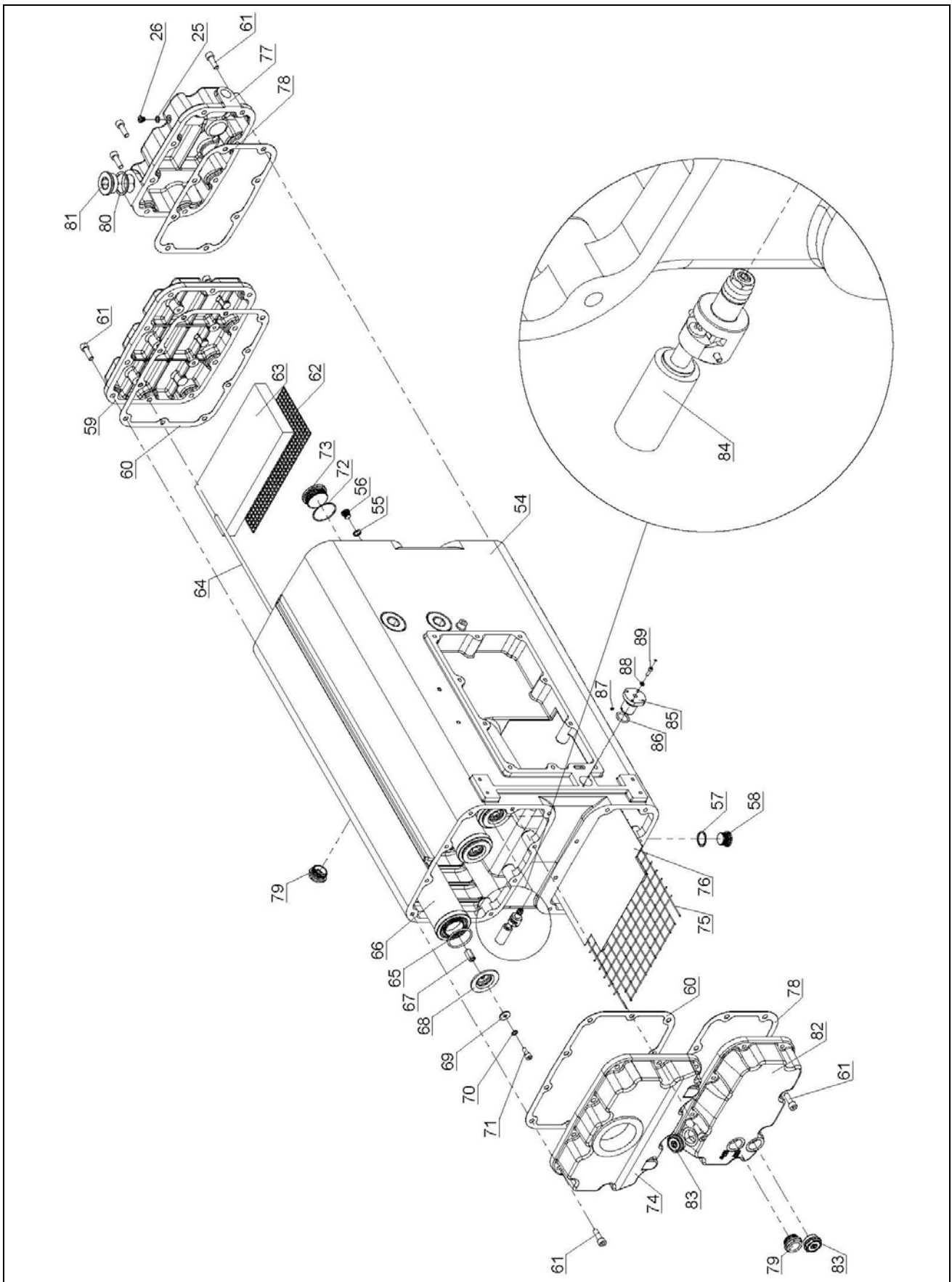

MS-631 Pump parts – Exploded View (4 of 4)

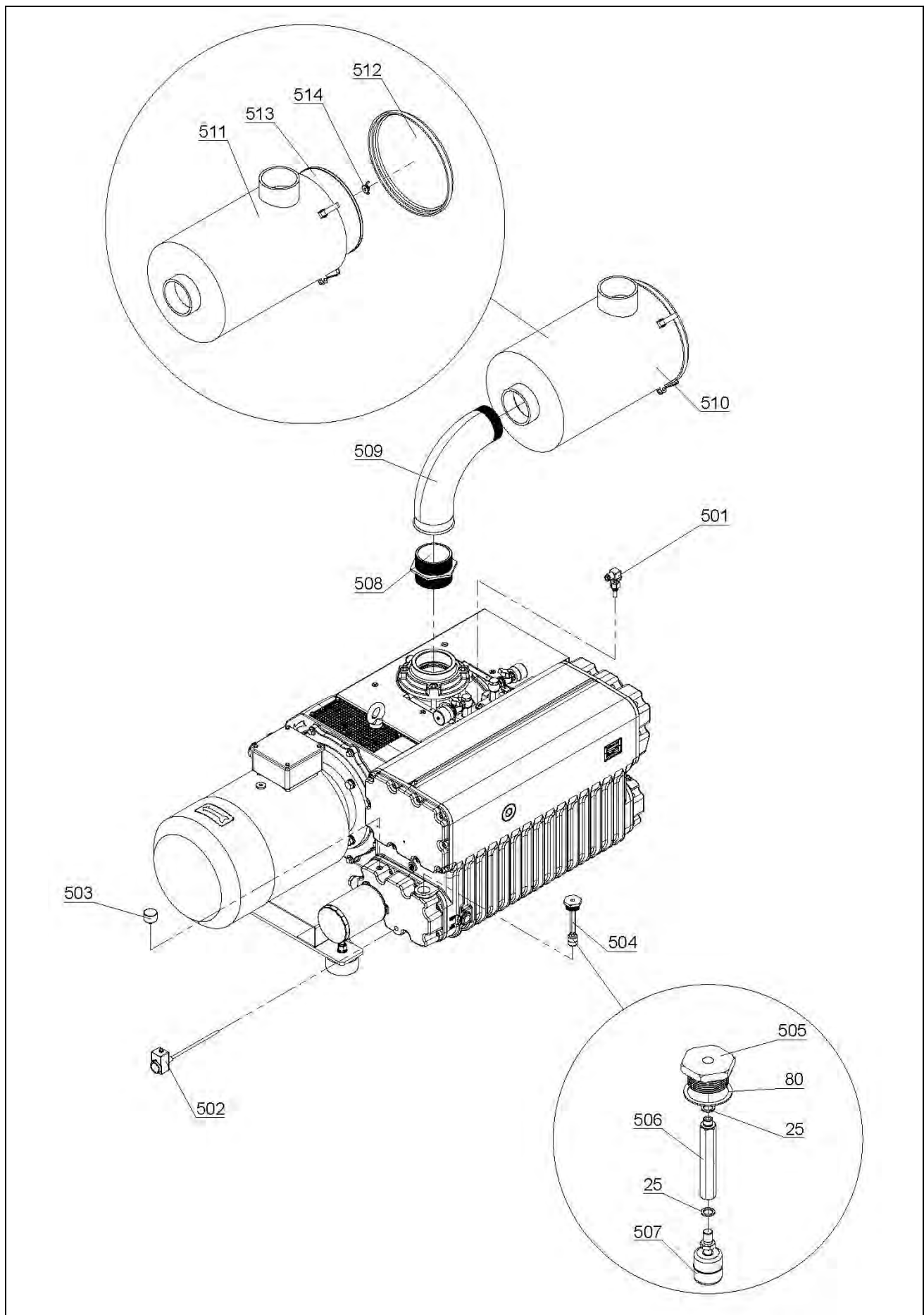

MS-631 Pump accessories – Exploded View

Pump Parts for MS-631

POS.	SPARE PARTS P/N	DESCRIPTION	Q.TY
1		Pump Body	1
2		Ø6x30 Pin	4
3	(B)	O Ring 41050	2
4		External side cover	1
5		M12x60 Hex. Screw (flanged and knurled)	11
6		D100 Space washer	1
7	(B)	6309 Ball bearing	2
8		Rotor	1
9	(B)	Vane	3
10	(B)	IR 45x50x35 Bushing	1
11		Motor side cover	1
12		Shim ring	1
13		Oil seal ring cover	1
14	(B)	BABSL 50x65x7 Seal ring	2
15		Seeger	1
16	(B)	O Ring 4400	1
17		M8x40 Hex. Screw (flanged and knurled)	3
18	(B)	Plate	4
19		Plate support	4
20		Ø6 Washer	12
21		Ø6 Lock washer	12
22		M6 x 16 Hex. Socket head screw	12
23		M5x12 Hex. Socket set screw	6
24		M6x16 Hex. Socket set screw	4
25		1/8"G Al Washer	7
26		1/8"G Plug	5
27		M10x25 Slotted headless set screw	2
28		3/8"G Al Washer	7
29		3/8"G Plug	7
30		A 12x8x70 Key	1
41	SR03705723	Pump Side Half Coupling	1
42	(A) (B)	Elastic coupling insert	1
43	(B)	Pump Body Spacer Gasket	1
44		Pump-tank spacer	1
45		M10x70 Hex. Socket head screw	10
46		M10x35 Stud bolt	10
47		M10 Nut (flanged and knurled)	10
48	(B)	Tank-spacer gasket	1
54		Tank	1
55		1/4"G Al Washer	1
56		1/4"G Plug	1
57		3/4"G Al Washer	1

POS.	SPARE PARTS P/N	DESCRIPTION	Q.TY
58		3/4"G Plug	1
59		Motor Side Upper Cover	1
60	(A) (B)	Upper cover gasket	2
61		M10 x 35 Hex. Socket head screw	36
62		Demister support mesh	1
63		Tank demister	1
64		Stay bolt for exhaust filter	5
65	(A) (B)	O Ring 4200	10
66	(A) (B)	Exhaust filter	5
67		Exhaust filter stay bolt sleeve	5
68		Disk for exhaust filter	5
69		Ø8/24 Washer	5
70		Al ø8.4/13x1 Washer	5
71		M8 x 20 Hex. Socket head screw	5
72		1"1/2 G Al Washer	6
73		1"1/2 Gas Plug	6
74		External side upper cover	1
75		Tank mesh	1
76		Tank micro-stretched sheet	1
77		Motor side lower cover	1
78	(B)	Gasket for lower cover	2
79		1" Oil sight glass	2
80		1" 1/4G Al Washer	2
81		1"1/4G Plug	1
82		Ext. side lower tank cover	1
83		1"G Filling/discharge plug	2
84		Float (oil recovery)	1
85		Float port	1
86	(B)	O Ring 4093	1
87		M4x8 Hex. Sock. Stud bolt	1
88		Ø5 Washer	2
89		M5x16 Hex. Socket head screw	2
90		1"1/4G Nipple	1
91	(A) (B)	Oil filter	1
102	(B) (C)	O Ring 4512	3
103		Inlet valve body	1
104	(C)	Helicoidally spring	1
105	(C)	Inlet valve plate	1
106		Inlet valve disk assembly	1
107	(B) (C)	O Ring 4362	1
108		Inlet flange	1
109		M16x95 Hex. Socket head screw	4
110		Oil cooler support	1

POS.	SPARE PARTS P/N	DESCRIPTION	Q.TY
111		M8x16 Hex. screw (flanged and knurled)	8
112		Oil cooler	1
113		Sleeve	1
114		M20 Eyebolt	1
115		M14 x 90 Hex. Socket head screw	3
116		Motor flange	1
117		M12x35 Hex. Screw (flanged and knurled)	8
118		Fan assembly	1
119A	SR03705726	Electrical Motor M180L B5 6P 15kW 50Hz	1
119B	SR03705727	Electrical Motor M200LA B5 6P 158.5kW 60Hz	1
120		Ø16 Washer	8
121		Ø16 Lock washer	8
122		M16x45 Hex. screw	4
123		Vibration damping foot extension (long)	4
124		Vibration damping foot	6
125		Vibration damping foot extension (short)	2
126		Casing assembly	1
127		Ø6 Washer	6
128		M6x12 Hex. head screw fully threaded	6
129		Casing cover	1
130		M6x12 Screw (flanged and knurled)	4
136		3/4"Gas Cu washer	4
137		Oil cooler-tank oil pipe	1
138		3/4"G Hollow bolt	2
139		3/8"G Cu washer	18
140		Motor side lubrication pipe	1
141		3/8"G Hollow bolt	9
142		Ext. Side lubrication pipe	1
143		1/4"G Cu washer	2
144		Central lubrication pipe	1
145		1/4"G Hollow bolt	1
146		1/8"G Cu washer	8
147		Oil pipe (outlet seal ring)	1
148		1/8"G Hollow bolt	4
149		Pump body support	2
150		M12x60 Hex. Socket head screw	4
151		Base-plate	1
152		Casing sheath	1
153		Ø12 Washer	6
154		Ø12 Lock washer	6
155		M12x25 Hex. head screw fully threaded	6
156		Ø100 Vibration damping foot	4

POS.	SPARE PARTS P/N	DESCRIPTION	Q.TY
157		M16 Nut	4
158		Eyebolt extension	1
164		M14 x 120 Hex. Socket head screw	1
165		Distributor for gas ballast valve	1
166		M8x20 Hex. Screw (flanged and knurled)	2
167		1/2"G Al Washer	3
168		M/F 1/2" Extension	2
169		1/2"G Cu washer	4
170		1/2"G Banjo male	2
171		1/2"G Ball valve	2
172		1/2"G Gas ballast valve	2
173		1/2"G felt disk for gas ballast valve	
174		1/2"G Hollow bolt	2
175		1/2"G Plug	1
176		Gas ballast pipe (front side)	1
177		Gas ballast pipe (rear side)	1
178		Oil recovery pipe	1
179		Pump name plate	1

POS.	SPARE PARTS	OPTIONALS	Q.TY
501		Safety temperature switch	1
502		Adjustable temperature switch	1
503		Vacuum gauge	1
504		Oil level switch assembly	1
505		Oil level switch port	1
506		Oil level switch extension	1
507		Oil level switch	1
508		4"G N8 Nipple	1
509		4"G M-F G4 Union fitting	1
510		Complete inlet filter	1
511		Filter housing	1
512		Filter cover	1
513		Filter element	1
514		Wing nut	1

NOTES

- (A) Part of MS-631 Minor Maintenance Kit (P/N 949-5087)
- (B) Part of MS-631 Major Maintenance Kit (P/N 949-5088)
- (C) Part of MS-631 Inlet Valve Kit (P/N SR03705717)

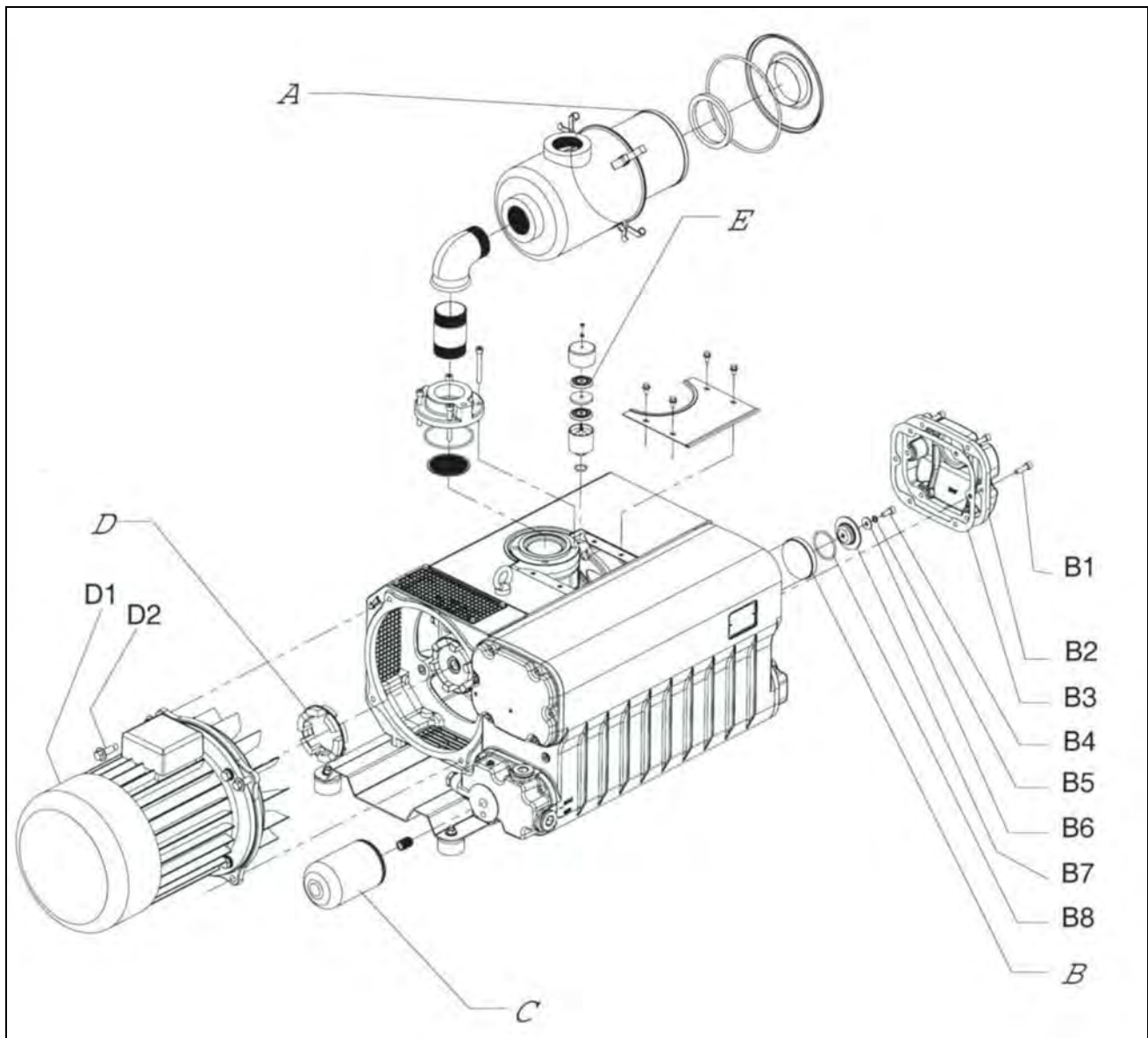

Pumps Major Parts

Oil change procedure

Oil change must be performed when the pump is still warm.

**WARNING!**

Use protective gloves to avoid any injury caused by heat.

Please refer to Figure "Oil change parts identification", (page 22).

Unscrew the oil filling plug (E) and the discharge plug (G) only after having placed underneath the pump tank a suitable container (proper size and shape), for collecting the total amount of oil.

Once the oil in the tank has completely been discharged, tighten both plugs "E" and "G" and let the

pump run for about one minute, so that the lubricating/cooling line gets emptied as any oil residual inside the pump. Then remove the plugs and discharge the rest of the oil.

If the oil is polluted or if some water is in the oil, clean the pump by letting it run at maximum vacuum level with about 2 liters of fresh oil for at least 5 minutes for the MS-301 and 14 liters of fresh oil at least 5 minutes for the MS-631.

Change again the lubricating oil.

Before filling the pump with fresh oil, replace the oil filter. Please remember to grease the filter gasket with fresh oil. Then screw the new oil filter.

Fill the pump with fresh oil (please see "Recommended oil" table).

Float valve cleaning procedure

If the float valve for oil recovery doesn't operate well, there could be oil carry out from the discharge port.

To clean the float valve, follow these instructions;

- 1) Remove the cover (position B2, refer to page 40), unscrewing the screws (position B1, refer to page 40).
- 2) Remove the float valve (position F of the following figure) from its grub-screw (position F1 of the following figure).
- 3) Clean the float valve, and its internal reduction fitting, with compressed air by blowing the opposite direction with respect to the normal oil flow
- 4) Fit the float valve in its housing.
- 5) Fit the discharge cover.

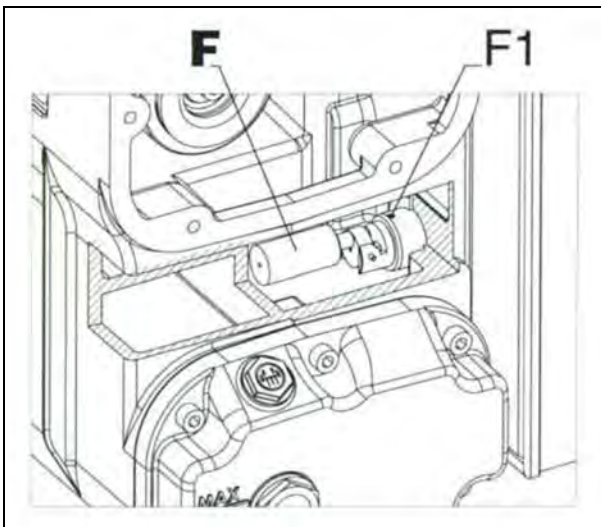
**Exhaust filters replacement procedure**

Very dirty exhaust filters may cause a considerable pump temperature increase and in extreme cases oil lubricant spontaneous ignition.

Maximum allowed pressure in the tank is 0.7 bar measured at the maximum capacity, when the pump is working with the inlet open to atmospheric pressure.

If a pressure gauge has been fitted on the tank, check the exhaust filter blockage with the pump warm.

To replace the filter apply the following instructions;

- 1) Remove the cover (position B2, refer to page 40) by unscrewing its screws (position B1, refer to page 40).
- 2) Unscrew the screw (position B4, refer to page 40), remove the washer (position B5-B6, refer to page 40) and then the fixing cartridge disk

(position B7, refer to page 40), the washer and tighten the screws.

- 3) Re-assemble the discharge cover. If necessary, replace the gasket (position B3, refer to page 40).

Oil separator change procedure

If the oil filter is clogged, the oil circulating from the tank through the pump could be dirt and cause a severe damage to the pump.

To change the oil filter (position C, refer to page 40), follow these instructions:

- 1) Be sure that the oil inside the pump has been completely discharged (for further information see the "Oil change procedure");
- 2) Unscrew the oil filter with by means of a chain wrench from the oil-tank;
- 3) Clean the contact surface between the oil tank and the filter;
- 4) Screw the oil filter by hands to the oil-tank.

Gas ballast felt disk change procedure

If the gas ballast felt disk is clogged, an insufficient amount of air flows through the pump and consequently the pump may not discharge the water vapor properly.

To change the gas ballast felt disk, follow these instructions:

- 1) Remove the gas ballast;
- 2) Unscrew its cap;
- 3) Remove the upper micro-stretched sheet disk;
- 4) Substitute the felt disk with a new one;
- 5) Re-assembly the gas ballast and then screw it using a new o-ring directly on the Ball valve.

Coupling elastic element replacement procedure

Please refer to figure "Pumps Major Parts" on page 40.

Remove the motor assembly (position D1, refer to page 40) unscrewing the screws (position D2, refer to page 40). Check the elastic element (position D, refer to page 40) conditions. If necessary, replace it. Re-assemble by means of the screws.

**CAUTION**

Use suitable lifting equipment to lift the motor;

- Motor weight for MS-301: approximately 55 kg
- Motor weight for MS-631: approximately 190 kg

**WARNING!**

The operation with damaged elastic element causes an anomalous pump noise, especially when starting the pump and may lead to coupling and pump shaft failure.

Pump overhaul procedure

For this operation please require the proper instructions and direct any questions to our Customer Service department.

The overhaul consists of a complete disassembly, cleaning of all components as well as replacement of parts that are subject to wear (pump and motor bearings, vanes and gaskets).

SPARE PARTS**Spares necessary for normal servicing**

Varian recommends the use of spare parts as follows;

- 1) Spare parts included in the "Minor Maintenance Kit" listed on pages 32 and 39 with (A) and indicated in the relevant Pump Parts tables. These parts are needed for ordinary maintenance operations to be performed by users or by Varian personnel.
- 2) Spare parts included in the "Major Maintenance Kit" listed on pages 32 and 39 with (B) and indicated in the relevant Pump Parts tables. These parts are needed for more complex maintenance operations to be performed mostly by Varian personnel.
- 3) Spare parts included in the "Inlet Valve Kit" listed on pages 32 and 39 with (C) and indicated in the relevant Pump Parts tables. These parts are needed in case of anti-suckback valve maintenance.
- 4) Other spare parts, listed with (SR....) on the Pump Parts tables at pages 31 and 38 are available for sales to Varian customers.

How to order spare parts

When ordering spare parts, always state the pump model (type), serial number, year of production, electric motor characteristics (three-phase, power, voltage, frequency), position reference on the spare parts list, description and quantity needed.

Orderable parts

DESCRIPTION	PART NUMBER
Major Spare Parts Kit (for MS-301 models)	949-5021
Minor Spare Parts Kit (for MS-301 models)	949-5020
Inlet Valve Kit (for MS-301 models)	SR03705715
Major Spare Parts Kit (for MS-631 models)	949-5088
Minor Spare Parts Kit (for MS-631 models)	949-5087
Inlet Valve Kit (for MS-631 models)	SR03705717
Oil filter (for MS-301 models)	949-5070
Oil filter (for MS-631 models)	949-5090
Inlet Air Filter with Polyester Cartridge (for MS-301 models)	949-5083
Inlet Air Filter with Polyester Cartridge for 2" gas connection (for MS-301 models)	949-5059
Inlet Air Filter with Polyester Cartridge with DN 63 ISO-K flange connection (for MS-301 models)	949-5159
Connection Fitting Kit, for 2" Gas connection (for MS-301 models)	949-5065
Connection Fitting Kit, DN 63 ISO-K flange connection (for MS-301 models)	949-5165
Oil Level Protection Switch (for MS-301 models)	949-5078
Inlet Air Filter with Polyester Cartridge (for MS-631 models)	949-5089
Inlet Air Filter with Polyester Cartridge for 4" gas connection (for MS-631 models)	949-5062
Inlet Air Filter with Polyester Cartridge with DN 100 ISO-K flange connection (for MS-631 models)	949-5162
Connection Fitting Kit, for 4" Gas connection (for MS-631 models)	949-5066
Connection Fitting Kit, DN 100 ISO-K flange connection (for MS-631 models)	949-5166
Oil Level Protection Switch (for MS-631 models)	949-5079
Pump Thermal Protection Switch	949-5076
Oil Separator Control Pressure Switch	949-5077
Pump side coupling half (for MS-301)	SR03705716
Elastic coupling insert (for MS-301)	SR03705719
Motor side coupling half (for MS-301)	SR03705718
Electric motor M132 B5 4P 5.5kW 50Hz (for MS-301)	SR03705592
Electric motor M132 B5 4P 7.5kW 60Hz (for MS-301)	SR03705721
Pump side Coupling half (for MS-631)	SR03705723
Electric motor M180L B5 6P 15kW 50Hz (for MS-631)	SR03705726
Electric motor M200LA B5 6P 18.5kW 60Hz (for MS-631)	SR03705727

DE-COMMISSIONING

Drain the oil from the pump prior to the removal.

If the oil is polluted, flush the pump with fresh oil (see "Oil change procedure" paragraph).

Drain the oil from the tank, plug the inlet and the discharge ports and store the pump without oil.

In case of pump disposal, separate the pump parts by materials and trash the parts in accordance with the local regulations in the Country of use.

RETURN FOR REPAIR

In case of pump return for repair to Varian, please provide a list of substances which have come in contact with the pump and advice the risks involved in handling, if any. Drain the lubricant from the pump prior to shipping the pump back.

TROUBLESHOOTING

TROUBLE	CAUSE	REMEDY	WHO
Drop in performances	Inlet filters are dirty	Clean or replace	Customer
	Inlet pipes or machine are leaking	Identify leaking point and seal it.	Customer
	No or low lubrication	Check oil level and oil conditions Fill with oil to the right level or change the oil	Customer
Anomalous noise	No lubrication	See previous point	Customer
	Worn out coupling element	Replace it following the supplied instructions	Customer
	Motor or pump bearings damaged	Call Varian Technical support	Varian Service
	Worn out vanes	Call Varian Technical support	Varian Service
Oil leak	Worn out shaft oil seal rings	Replace oil seal rings	Varian Service
	Oil recovery system leak	Check and clean oil recovery pipe	Customer
Motor protection is tripping	Blocked exhaust filters	Replace exhaust filters	Customer
	No or low lubrication	Oil level filling up	Customer
	Pump seizure and jelly oil	Pump overhaul	Varian Service
Discharge oil mist	Clogged exhaust filters	Replace exhaust filters	Customer
	High temperature due to polluted oil	Oil change	Customer
	High operating temperature due to high ambient temperature	Decrease room temperature by allowing a better change of air	Customer

Request for Return



1. A Return Authorization Number (RA#) **WILL NOT** be issued until this Request for Return is completely filled out, signed and returned to Varian Customer Service.
2. Return shipments shall be made in compliance with local and international **Shipping Regulations** (IATA, DOT, UN).
3. The customer is expected to take the following actions to ensure the **Safety** of workers at Varian: (a) Drain any oils or other liquids, (b) Purge or flush all gasses, (c) Wipe off any excess residues in or on the equipment, (d) Package the equipment to prevent shipping damage, (for Advance Exchanges please use packing material from replacement unit).
4. Make sure the shipping documents clearly show the RA# and then return the package to the Varian location nearest you.

CUSTOMER INFORMATION

Company name:		Contact person:	
Name:	Tel:	E-Mail:	
Ship Method:	Shipping Collect #:	P.O.#:	
<i>Europe only:</i> VAT reg. Number:		<i>USA only:</i> <input type="checkbox"/> Taxable <input type="checkbox"/> Non-taxable	
Customer Ship To:		Customer Bill To:	
.....		
.....		

PRODUCT IDENTIFICATION

Product Description	Varian P/N	Varian S/N	Purchase Reference

TYPE OF RETURN (check appropriate box)

<input type="checkbox"/> Paid Exchange	<input type="checkbox"/> Paid Repair	<input type="checkbox"/> Warranty Exchange	<input type="checkbox"/> Warranty Repair	<input type="checkbox"/> Loaner Return
<input type="checkbox"/> Credit	<input type="checkbox"/> Shipping Error	<input type="checkbox"/> Evaluation Return	<input type="checkbox"/> Calibration	<input type="checkbox"/> Other

HEALTH and SAFETY CERTIFICATION

Varian Vacuum Technologies **CAN NOT ACCEPT** any equipment which contains **BIOLOGICAL HAZARDS** or **RADIOACTIVITY**. Call Varian Customer Service to discuss alternatives if this requirement presents a problem.

The equipment listed above (check one):

HAS NOT been exposed to any toxic or hazardous materials

OR

HAS been exposed to any toxic or hazardous materials. In case of this selection, check boxes for any materials that equipment was exposed to, check all categories that apply:

Toxic Corrosive Reactive Flammable Explosive Biological Radioactive

List all toxic or hazardous materials. Include product name, chemical name and chemical symbol or formula.

.....

Print Name: Customer Authorized Signature:

Print Title: Date:/...../.....

NOTE: If a product is received at Varian which is contaminated with a toxic or hazardous material that was not disclosed, **the customer will be held responsible** for all costs incurred to ensure the safe handling of the product, and **is liable** for any harm or injury to Varian employees as well as to any third party occurring as a result of exposure to toxic or hazardous materials present in the product.

Do not write below this line

Notification (RA)#: Customer ID#: Equipment #:

Request for Return



FAILURE REPORT

TURBO PUMPS and TURBOCONTROLLERS

<input type="checkbox"/> Does not start <input type="checkbox"/> Does not spin freely <input type="checkbox"/> Does not reach full speed <input type="checkbox"/> Mechanical Contact <input type="checkbox"/> Cooling defective	<input type="checkbox"/> Noise <input type="checkbox"/> Vibrations <input type="checkbox"/> Leak <input type="checkbox"/> Overtemperature	POSITION <input type="checkbox"/> Vertical <input type="checkbox"/> Horizontal <input type="checkbox"/> Upside-down <input type="checkbox"/> Other:	PARAMETERS Power: Rotational Speed: Current: Inlet Pressure: Temp 1: Foreline Pressure: Temp 2: Purge flow: <hr/> OPERATION TIME:
TURBOCONTROLLER ERROR MESSAGE:			

ION PUMPS/CONTROLLERS

<input type="checkbox"/> Bad feedthrough <input type="checkbox"/> Vacuum leak <input type="checkbox"/> Error code on display	<input type="checkbox"/> Poor vacuum <input type="checkbox"/> High voltage problem <input type="checkbox"/> Other
Customer application:	

VALVES/COMPONENTS

<input type="checkbox"/> Main seal leak <input type="checkbox"/> Solenoid failure <input type="checkbox"/> Damaged sealing area	<input type="checkbox"/> Bellows leak <input type="checkbox"/> Damaged flange <input type="checkbox"/> Other
Customer application:	

LEAK DETECTORS

<input type="checkbox"/> Cannot calibrate <input type="checkbox"/> Vacuum system unstable <input type="checkbox"/> Failed to start	<input type="checkbox"/> No zero/high background <input type="checkbox"/> Cannot reach test mode <input type="checkbox"/> Other
Customer application:	

INSTRUMENTS

<input type="checkbox"/> Gauge tube not working <input type="checkbox"/> Communication failure <input type="checkbox"/> Error code on display	<input type="checkbox"/> Display problem <input type="checkbox"/> Degas not working <input type="checkbox"/> Other
Customer application:	

PRIMARY PUMPS

<input type="checkbox"/> Pump doesn't start <input type="checkbox"/> Doesn't reach vacuum <input type="checkbox"/> Pump seized	<input type="checkbox"/> Noisy pump (describe) <input type="checkbox"/> Over temperature <input type="checkbox"/> Other
Customer application:	

DIFFUSION PUMPS

<input type="checkbox"/> Heater failure <input type="checkbox"/> Doesn't reach vacuum <input type="checkbox"/> Vacuum leak	<input type="checkbox"/> Electrical problem <input type="checkbox"/> Cooling coil damage <input type="checkbox"/> Other
Customer application:	

FAILURE DESCRIPTION

(Please describe in detail the nature of the malfunction to assist us in performing failure analysis):

NOTA: Su richiesta questo documento è disponibile anche in Tedesco, Italiano e Francese.

REMARQUE : Sur demande ce document est également disponible en allemand, italien et français.

HINWEIS: Auf Anfrage ist diese Unterlage auch auf Deutsch, Italienisch und Französisch erhältlich.