

Chemtech Scientific provides access to this content as a courtesy.
We do not own the content contained in this document.
All rights and credit go directly to its rightful owners.
www.chemtechsci.com
Call us at: 484-424-9415



HS452 ***HS652*** ***Rotary Vane Pumps***

Model 949-9360
Model 949-9365

- (I) MANUALE DI ISTRUZIONI*
- (D) BEDIENUNGSHANDBUCH*
- (F) NOTICE DE MODE D'EMPLOI*
- (GB) INSTRUCTION MANUAL*

HS452 – HS652
ROTARY VANE PUMPS



Chemtech Scientific provides access to this content as a courtesy.
We do not own the content contained in this document.
All rights and credit go directly to its rightful owners.
www.chemtechsci.com
Call us at: 484-424-9415



Dear Customer,

Thank you for purchasing a VARIAN vacuum product. At VARIAN Vacuum Technologies we make every effort to ensure that you will be satisfied with the product and/or service you have purchased.

As part of our Continuous Improvement effort, we ask that you report to us any problem you may have had with the purchase or operation of our product. On the back side you find a Corrective Action Request form that you may fill out in the first part and return to us.

This form is intended to supplement normal lines of communications and to resolve problems that existing systems are not addressing in an adequate or timely manner.

Upon receipt of your Corrective Action Request we will determine the Root Cause of the problem and take the necessary actions to eliminate it. You will be contacted by one of our employees who will review the problem with you and update you, with the second part of the same form, on our actions.

Your business is very important to us. Please, take the time and let us know how we can improve.

Sincerely,

A handwritten signature in black ink, appearing to read "Sergio Piras", written over a horizontal line.

Sergio PIRAS

Vice President and General Manager
VARIAN Vacuum Technologies

CUSTOMER REQUEST FOR CORRECTIVE / PREVENTIVE / IMPROVEMENT ACTION

TO : VARIAN VACUUM TECHNOLOGIES TORINO - QUALITY ASSURANCE

FAX N° : XXXX - 011 - 9979350



ADDRESS: VARIAN S.p.A. - Via F.lli Varian, 54 - 10040 Leinì (Torino) - Italy

E-MAIL : marco.marzio@varianinc.com

NAME _____	COMPANY _____	FUNCTION _____
ADDRESS : _____ TEL. N° : _____ FAX N° : _____ E-MAIL : _____		
PROBLEM / SUGGESTION : _____ _____ _____ _____		
REFERENCE INFORMATION (model n°, serial n°, ordering information, time to failure after installation, etc.) : _____ _____ _____ DATE _____		

CORRECTIVE ACTION PLAN / ACTUATION (by VARIAN VTT) _____ _____ _____ _____ _____	LOG N° _____
--	--------------

XXXX = Code for dialing Italy from your country (es. 01139 from USA; 00139 from Japan, etc.)

ISTRUZIONI PER L'USO	1
GEBRAUCHSANLEITUNG	3
MODE D'EMPLOI	5
INSTRUCTIONS FOR USE	7
TECHNICAL INFORMATION	9
SECTION I	9
TECHNICAL DESCRIPTION	9
LUBRICATION	9
VACUUM SEALS	10
GAS BALLAST VALVE	10
ANTI-SUCKBACK DEVICE	10
TECHNICAL DATA	13
DIMENSIONS	14
SAFETY PRECAUTIONS	15
TRANSPORT AND INSTALLATION	15
PRELIMINARY OPERATIONS	15
SECTION II	16
CONNECTION TO THE ELECTRIC SUPPLY	16
CONNECTIONS TO THE INLET AND EXHAUST FLANGES	16
STARTING AND RUNNING THE PUMP	16
STOPPING THE PUMP	17
SAFETY RULES	17
WARNING NOTES 	17
CAUTION NOTES 	18
MAINTENANCE ACTIONS	18
LUBRICANTS	19
PUMP ELECTRONIC CONTROLLER	21
Technical specifications	21
Input/Output communications:	21
RS 232/RS 485 COMMUNICATION DESCRIPTION	21
J2 – Serial Port	21
Communication Format	22
Communication Protocol	22
Windows meaning	23
Electronic self-test	24
Rotor lock test	24
Oil level check	24
IP44 Accessory Kit P/N 949-9367	24
Protection against solids	24
Protection against liquids	24
IP44 Accessory kit items	24
IP44 Accessory kit use	25
Accessories	25

INFORMAZIONI GENERALI

Questa apparecchiatura è destinata ad uso professionale. L'utilizzatore deve leggere attentamente il presente manuale di istruzioni ed ogni altra informazione addizionale fornita dalla Varian prima dell'utilizzo dell'apparecchiatura. La Varian si ritiene sollevata da eventuali responsabilità dovute all'inosservanza totale o parziale delle istruzioni, ad uso improprio da parte di personale non addestrato, ad interventi non autorizzati o ad uso contrario alle normative nazionali specifiche.

Le pompe HS452 e HS652 sono delle pompe rotative bistadio a palette, a tenuta in bagno d'olio, azionate da motore elettrico monofase.

Queste pompe da alto vuoto sono adatte al pompaggio di gas non corrosivi.

Nei paragrafi seguenti sono riportate tutte le informazioni necessarie a garantire la sicurezza dell'operatore durante l'utilizzo dell'apparecchiatura. Informazioni dettagliate sono fornite nell'appendice "Technical information".

Questo manuale utilizza le seguenti convenzioni:



PERICOLO!

I messaggi di pericolo attirano l'attenzione dell'operatore su una procedura o una pratica specifica che, se non eseguita in modo corretto, potrebbe provocare gravi lesioni personali.



ATTENZIONE!

I messaggi di attenzione sono visualizzati prima di procedure che, se non osservate, potrebbero causare danni all'apparecchiatura.

NOTA

Le note contengono informazioni importanti estrapolate dal testo.

IMMAGAZZINAMENTO

Durante il trasporto e l'immagazzinamento delle pompe non devono essere superate le seguenti condizioni ambientali:

- temperatura: da -20 °C a +70 °C
- umidità relativa: 0 - 95% (non condensante)

PREPARAZIONE PER L'INSTALLAZIONE

La pompa viene fornita in un imballo protettivo speciale; se si presentano segni di danni, che potrebbero essersi verificati durante il trasporto, contattare l'ufficio vendite locale.

Il peso dell'imballo, comprensivo della pompa, è, al massimo, di circa 36 [Kg].

Durante l'operazione di disimballaggio, prestare particolare attenzione a non lasciar cadere la pompa e a non sottoporla ad urti o vibrazioni.

Non disperdere l'imballo nell'ambiente. Il materiale è completamente riciclabile e risponde alla direttiva CEE 85/399 per la tutela dell'ambiente.

NOTA

La pompa non può essere danneggiata rimanendo semplicemente esposta all'atmosfera. Si consiglia comunque di mantenerla chiusa fino al momento dell'installazione sul sistema onde evitare eventuale inquinamento da polvere.

NOTA

La pompa è fornita con alcuni accessori standard:

- 1 bottiglia di olio Varian GP
- 1 connettore "D" a 9 contatti per I/O (femmina)
- 1 connettore "D" a 9 contatti per RS232 (maschio)
- 1 fusibile T10A

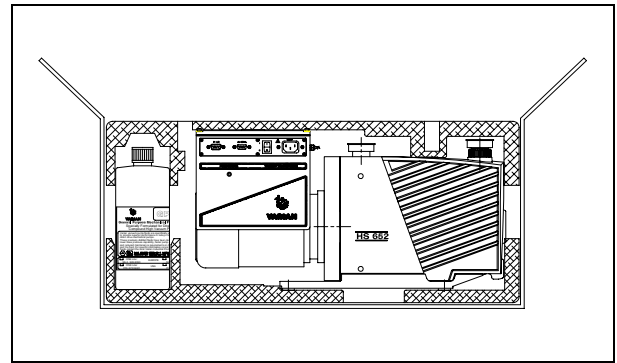

INSTALLAZIONE

Non installare e/o utilizzare la pompa in ambienti esposti ad agenti atmosferici (pioggia, gelo, neve), polveri, gas aggressivi, in ambienti esplosivi o con elevato rischio di incendio.

Durante il funzionamento è necessario che siano rispettate le seguenti condizioni ambientali:

- temperatura: da +12 °C a +40 °C
- umidità relativa: 0 - 95% (non condensante).



PERICOLO!

Per proteggere contro corto-circuiti o sovraccarichi, si deve installare un interruttore automatico sulla linea d'alimentazione principale verso i dispositivi Varian, di capacità adeguata (vedere la tabella seguente):

P/N	110 Vac	220 Vac
949-9360	10 A	
949-9365		6 A



ATTENZIONE!

Prima di avviare la pompa, occorre procedere al rifornimento di olio lubrificante, poiché la pompa viene fornita scarica.



PERICOLO!

Togliere i tappi di protezione posti sulle flange di aspirazione e scarico prima di ogni successiva operazione. L'aria contenuta all'interno della pompa, in caso di accensione involontaria, può proiettarli contro l'operatore.



PERICOLO!

Durante l'installazione prestare la massima attenzione che la flangia di aspirazione sia collegata alla camera da evacuare e che la flangia di scarico non sia tappata (vedere la figura seguente).

La pompa non deve essere usata come compressore.

La massima pressione interna al contenitore dell'olio non deve superare 1,5 bar (abs).

L'inosservanza di queste precauzioni può causare danni alla macchina ed all'operatore.

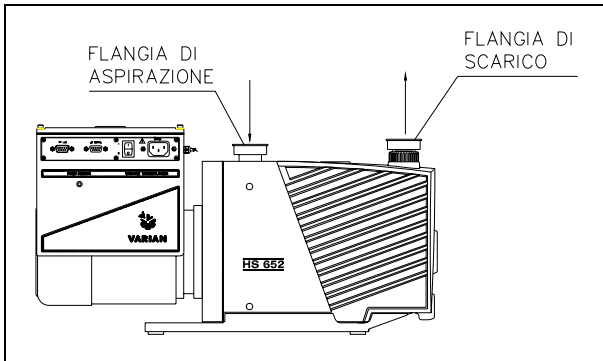

ATTENZIONE!

Controllare che la tensione di alimentazione corrisponda a quella indicata sul cartellino del motore.

Collegare la pompa all'alimentazione.

USO

Prima di mettere la pompa in servizio effettivo è necessario, per il raggiungimento del vuoto limite, far marciare per circa un'ora la pompa con zavorra aperta allo scopo di eliminare l'umidità nell'olio.

L'accensione della pompa non richiede particolari manovre; è sufficiente collegarla all'alimentazione elettrica agendo sull'interruttore bipolare.

PERICOLO!

La pompa è progettata per operare con fluidi neutri o non corrosivi. È assolutamente vietato l'impiego con sostanze potenzialmente esplosive o infiammabili.

MANUTENZIONE

Il personale addetto alla condotta ed alla manutenzione della pompa deve essere ben addestrato e deve avere un'approfondita conoscenza delle norme antinfortunistiche.

PERICOLO!

Le alte tensioni possono causare morte al contatto. Operare sempre con la massima cautela e secondo le norme antinfortunistiche in vigore.

PERICOLO!

Quando la macchina è alimentata prestare attenzione per la presenza di parti in movimento e di alta tensione.

PERICOLO!

Nel caso si debba procedere ad operazioni di manutenzione della pompa al termine di un periodo di esercizio, è necessario lasciarla raffreddare, poiché la temperatura esterna può superare i 60 °C.

PERICOLO!

Escludere sempre l'alimentazione della pompa prima di compiere operazioni di manutenzione. Apporre specifici cartelli di avvertenza: APPARECCHIATURA IN MANUTENZIONE - NON INSERIRE L'ALIMENTAZIONE, in corrispondenza dell'interruttore di alimentazione. Al termine ripristinare i dispositivi di sicurezza.

PERICOLO!

Non effettuare la sostituzione dell'olio subito dopo l'arresto della macchina, in quanto la temperatura dello stesso può essere elevata.

NOTA

Prima di rispedire al costruttore una pompa per riparazioni è indispensabile compilare e far pervenire al locale ufficio vendite la scheda "Sicurezza e Salute" allegata al presente manuale di istruzioni. Copia della stessa deve essere inserita nell'imballo della pompa prima della spedizione.

Qualora una pompa dovesse essere rottamata, procedere alla sua eliminazione nel rispetto delle normative nazionali specifiche.

SMALTIMENTO

Significato del logo "WEEE" presente sulle etichette

Il simbolo qui sotto riportato applicato in ottemperanza alla direttiva CE denominata "WEEE".

Questo simbolo (**valido solo per i paesi della Comunità Europea**) indica che il prodotto sul quale è applicato, NON deve essere smaltito insieme ai comuni rifiuti domestici o industriali, ma deve essere avviato ad un sistema di raccolta differenziata.

Si invita pertanto l'utente finale a contattare il fornitore del dispositivo, sia esso la casa madre o un rivenditore, per avviare il processo di raccolta e smaltimento, dopo opportuna verifica dei termini e condizioni contrattuali di vendita.



ALLGEMEINE HINWEISE

Dieses Gerät ist für den professionellen Gebrauch bestimmt. Vor dem Gebrauch soll der Benutzer dieses Handbuch sowie alle weiteren von Varian mitgelieferten Zusatzinformationen genau lesen. Bei vollständiger bzw. teilweiser Nichtbeachtung der enthaltenen Hinweise, unsachgemäßem Gebrauch durch ungeschultes Personal, nicht autorisierten Eingriffen und Benutzung unter Mißachtung der nationalen Bestimmungen übernimmt Firma Varian keinerlei Haftung.

Die Pumpen HS452 und HS652 sind dichte ölbadgeschmierte zweistufige Flügelzellenpumpen, die von einem Einphasenstrommotor betätigt werden.

Diese Hochvakuumpumpen eignen sich für das Pumpen von nicht korrosiven Gasen.

In den folgenden Abschnitten sind alle erforderlichen Informationen für die Sicherheit des Bedieners bei der Verwendung des Geräts aufgeführt. Detaillierte technische Informationen sind im Anhang "Technical Information" enthalten.

In dieser Gebrauchsanleitung werden Sicherheitshinweise folgendermaßen hervorgehoben:



GEFAHR!

Die Gefahrenhinweise richten die Aufmerksamkeit des Bedieners auf eine spezielle Prozedur oder Praktik, die bei unkorrekter Ausführung schwere Personenschäden zur Folge haben könnte.



ACHTUNG!

Die Warnhinweise vor bestimmten Prozeduren machen den Bediener darauf aufmerksam, daß bei Nichteinhaltung Schäden am Gerät entstehen können.

ANMERKUNG

Die Anmerkungen enthalten wichtige Informationen, die aus dem Text hervorgehoben werden.

LAGERUNG

Während des Transports und der Lagerung der Pumpen sollen die folgenden Umgebungsbedingungen gegeben sein:

- Temperatur: -20 °C bis +70 °C
- Relative Feuchtigkeit: 0 - 95% (niederschlagsfrei)

VOR DER INSTALLATION

Die Pumpe wird in einer speziellen Schutzverpackung geliefert. Eventuelle Transportschäden sind der zuständigen örtlichen Verkaufsstelle zu melden.

Das Verpackungsgewicht beträgt, einschließlich der Pumpe, maximal 36 Kg.

Beim Auspacken ist darauf zu achten, daß die Pumpe nicht fallengelassen oder Stößen oder Vibrationen ausgesetzt wird.

Das Verpackungsmaterial ist ordnungsgemäß zu entsorgen. Es ist vollständig recyclebar und entspricht der EG-Richtlinie 85/399 für den Umweltschutz.

ANMERKUNG

Die Pumpe kann, wenn sie einfach der Atmosphäre ausgesetzt ist, nicht beschädigt werden. Sie sollte jedoch bis zur Installation an der Anlage geschlossen bleiben, um Verunreinigungen durch Staub zu vermeiden.

ANMERKUNG

Die Pumpe wird mit einigen Standardzubehörteilen geliefert:

- 1 Ölfflasche Varian GP
- 1 9-Stift-Stecker "D" für I/O (Steckbuchse)
- 1 9-Stift-Stecker "D" für RS232 (Stecker)
- 1 Sicherung T10A

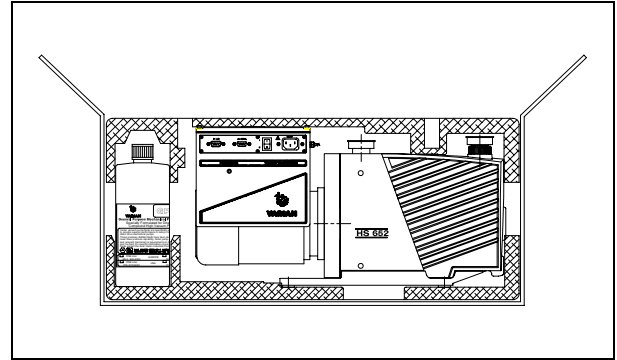

INSTALLATION

Die Pumpe darf nicht in Umgebungen installiert und/oder benutzt werden, die ungeschützt vor Witterungsbedingungen (Regen, Frost, Schnee), Staub und aggressiven Gasen sind und in denen Explosions- oder erhöhte Brandgefahr besteht. Während des Betriebs sollen die folgenden Umgebungsbedingungen gegeben sein:

- Temperatur: +12 °C bis +40 °C
- Relative Feuchtigkeit: 0 - 95% (niederschlagsfrei).



GEFAHR!

Zum Schutz vor Kurzschlüssen oder Überlastungen, muss ein automatischer Schalter in die Hauptspeisungsleitung zu den Varian-Vorrichtungen installiert werden (siehe folgende Tabelle):

P/N	110 Vac	220 Vac
949-9360	10 A	
949-9365		6 A



ACHTUNG!

Die Pumpe ist vor ihrer Inbetriebnahme mit Schmieröl zu füllen, da sie leer geliefert wird.



GEFAHR!

Vor Aufnahme jeglicher Arbeiten sind die Schutzkappen an den Saug- und Druckflanschen zu entfernen. Die im Pumpeninneren enthaltene Luft könnte diese bei unbeabsichtigter Einschaltung gegen den Bediener schleudern.



GEFAHR!

Bei der Installation ist unbedingt darauf zu achten, dass der Saugflansch an die zu entleerende Kammer angeschlossen ist und der Ablassflansch nicht verschlossen ist (siehe nachstehende Abbildung).

Die Pumpe darf nicht als Verdichter verwendet werden.

Der Druck im Ölbehälter darf nicht größer als 1,5 bar (abs) sein. Bei Nichtbeachtung dieser Anweisungen besteht Schadensgefahr für das Gerät und die Bedienperson.

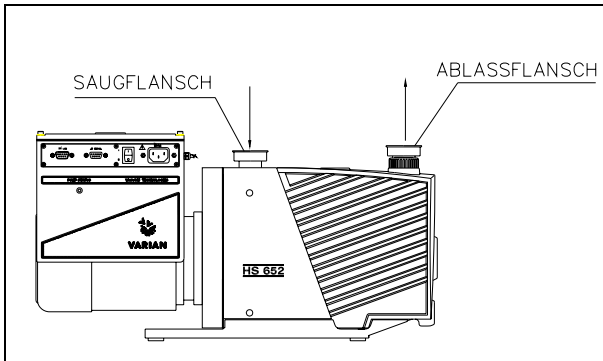

⚠️ ACHTUNG!

Kontrollieren, daß die Versorgungsspannung mit der Spannungsangabe auf dem Typenschild des Motors übereinstimmt.

Die Pumpe an das Versorgungsnetz anschließen.

GEBRAUCH

Vor der eigentlichen Inbetriebnahme der Pumpe ist es zur Erreichung des Grenzvakuums erforderlich, die Pumpe ungefähr eine Stunde mit geöffnetem Ballast laufen zu lassen, um die Feuchtigkeit aus dem Öl zu entfernen.

Die Einschaltung der Pumpe erfordert keine speziellen Schritte, sie braucht nur durch Betätigung des zweipoligen (Version mit Einphasenstrommotor) oder des allpoligen Trennschalters (Version mit Dreiphasenstrommotor) an die elektrische Energieversorgungsquelle angeschlossen werden.

⚠️ GEFAHR!

Die Pumpe ist für den Betrieb mit neutralen und nicht korrosiven Fluiden konzipiert. Der Einsatz mit potentiell explosions- oder feuergefährlichen Substanzen ist streng verboten.

WARTUNG

Das für den Betrieb und die Wartung zuständige Personal soll geschult sein und über eine solide Kenntnis der Unfallschutzvorschriften verfügen.

⚠️ GEFAHR!

Hochspannungen können bei Kontakt tödliche Folgen haben. Es ist stets mit größter Vorsicht und gemäß der geltenden Unfallschutzvorschriften vorzugehen.

⚠️ GEFAHR!

Bei eingeschaltetem Gerät ist auf Bewegungs- und Hochspannungsteile zu achten.

⚠️ GEFAHR!

Falls die Pumpe im Anschluß an den Betrieb gewartet werden soll, ist abzuwarten, bis sie abgekühlt ist, da ihre Oberfläche eine Temperatur von 60°C überschreiten kann.

⚠️ GEFAHR!

Vor Wartungsarbeiten ist die Pumpe stets energiefrei zu schalten. Am Netzschalter sind spezielle Warnschilder "INSTANDHALTUNG AM GERÄT – NICHT EINSCHALTEN" anzubringen. Nach Abschluß der Arbeiten sind die Sicherheitseinrichtungen wieder zu aktivieren.

⚠️ GEFAHR!

Keine Ölwechsel unmittelbar nach Stillsetzung des Gerätes vornehmen, da die Öltemperatur sehr hoch sein kann.

ANMERKUNG

Bevor dem Hersteller eine Pumpe zur Reparatur zurückgesandt wird, ist das Formular "Sicherheit und Gesundheit" in der Anlage zum vorliegenden Handbuch auszufüllen und der lokalen Verkaufsstelle zuzustellen. Eine Kopie des Formulars ist der Pumpenverpackung vor dem Versand beizulegen.

Bei eventueller Verschrottung einer Pumpe ist diese entsprechend der einschlägigen nationalen Vorschriften zu entsorgen.

ENTSORGUNG

Bedeutung des "WEEE" Logos auf den Etiketten

Das folgende Symbol ist in Übereinstimmung mit der EU-Richtlinie WEEE (Waste Electrical and Electronic Equipment) angebracht.

Dieses Symbol (**nur in den EU-Ländern gültig**) zeigt an, dass das betreffende Produkt nicht zusammen mit Haushaltsmüll entsorgt werden darf sondern einem speziellen Sammelsystem zugeführt werden muss.

Der Endabnehmer sollte daher den Lieferanten des Geräts - d.h. die Muttergesellschaft oder den Wiederverkäufer - kontaktieren, um den Entsorgungsprozess zu starten, nachdem er die Verkaufsbedingungen geprüft hat.

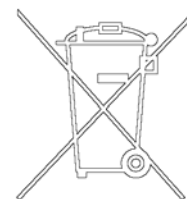

INDICATIONS GÉNÉRALES

Cet appareillage a été conçu en vue d'une utilisation professionnelle. Il est conseillé à l'utilisateur de lire attentivement cette notice d'instructions ainsi que toute autre indication fournie par Varian avant d'utiliser l'appareil. Varian décline par conséquent toute responsabilité en cas de non-respect total ou partiel des instructions fournies, d'utilisation incorrecte de la part d'un personnel non formé, d'opérations non autorisées ou d'un emploi contraire aux réglementations nationales spécifiques.

Les pompes HS452 e HS652 sont des pompes rotatives à deux stades à palettes, étanches en bain d'huile, actionnées par un moteur électrique monophasé.

Ces pompes à vide poussé sont adaptées au pompage de gaz non corrosifs.

Les paragraphes suivants fournissent toutes les indications nécessaires pour garantir la sécurité de l'opérateur pendant l'utilisation de l'appareillage. Des renseignements plus détaillés se trouvent dans l'appendice "Technical information".

Cette notice utilise les signes conventionnels suivants :



DANGER!

Les messages de danger attirent l'attention de l'opérateur sur une procédure ou une manœuvre spéciale dont la mauvaise exécution risque de provoquer de graves lésions.



ATTENTION!

Les messages d'attention apparaissent avant certaines procédures dont le non-respect peut endommager sérieusement l'appareillage.

NOTE

Les notes contiennent des renseignements importants, extrapolés du texte.

EMMAGASINAGE

Pendant le transport et l'emménagement des pompes, il faut veiller à respecter les conditions environnementales suivantes :

- température: de -20 °C à +70 °C
- humidité relative: 0 - 95% (non condensante)

PRÉPARATION POUR L'INSTALLATION

La pompe est fournie dans un emballage de protection spécial; si l'on constate des marques de dommages pouvant s'être produits pendant le transport, contacter aussitôt le bureau de vente local.

Le poids total de l'emballage et de la pompe est au maximum de 36 Kg.

Pendant l'opération d'ouverture de l'emballage, veiller tout particulièrement à ne pas laisser tomber la pompe et à ne lui faire subir aucun choc ni aucune vibration

Ne pas jeter l'emballage dans la nature. Le matériel est entièrement recyclable et il est conforme à la directive CEE 85/399 en matière de protection de l'environnement.

NOTE

La pompe ne peut être endommagée en restant simplement exposée à l'atmosphère. Il est de toute façon conseillé de la garder dans son emballage jusqu'au moment de sa mise en fonction afin d'éviter toute pollution due à la poussière

NOTE

La pompe est équipée de certains accessoires standard:

- 1 bouteille d'huile Varian GP
- 1 connecteur "D" à 9 broches pour E/S (femelle)
- 1 connecteur "D" à 9 broches pour RS232 (mâle)
- 1 fusible T10A

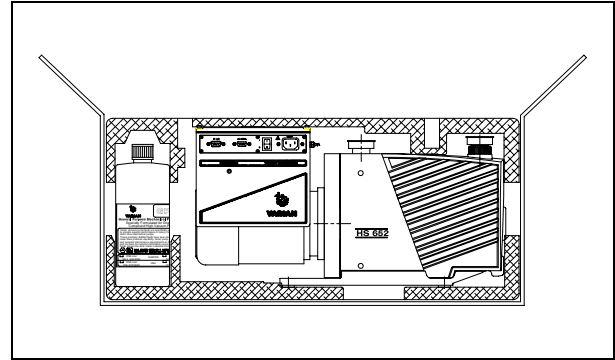

INSTALLATION

Ne pas installer et/ou utiliser la pompe dans des milieux exposés aux agents atmosphériques (pluie, gel, neige), à des poussières, à des gaz agressifs ainsi que dans des milieux explosifs ou à risque élevé d'incendie.

Pendant le fonctionnement, il est nécessaire de respecter les conditions environnementales suivantes :

- Température: de +12 °C à +40 °C
- Humidité relative : 0 - 95% (non condensante).



DANGER!

Pour protéger contre les court-circuits ou les surintensités, il faut installer un disjoncteur automatique sur la ligne d'alimentation principale vers les dispositifs Varian, de bonne capacité (voir tableau ci-dessous):

P/N	110 Vac	220 Vac
949-9360	10 A	
949-9365		6 A



ATTENTION!

Avant toute utilisation de la pompe, il est impératif de procéder à son remplissage en huile de lubrification car elle est livrée vide.



DANGER!

Avant toute autre opération, retirer les bouchons de protection placés sur les brides d'aspiration et de vidange. En cas de mise en marche inopinée de l'appareillage, l'air contenu à l'intérieur de la pompe peut les projeter contre l'opérateur.



DANGER!

Pendant l'installation, faire très attention que la bride d'aspiration soit reliée à la chambre à vider et que la bride d'évacuation ne soit pas bouchée (voir la figure ci-après).

La pompe ne doit pas être utilisée comme un compresseur.

La pression maximale à l'intérieur du réservoir d'huile ne doit pas dépasser 1,5 bar (abs).

Le non-respect de ces précautions peut entraîner un danger pour l'opérateur et l'endommagement de la machine.

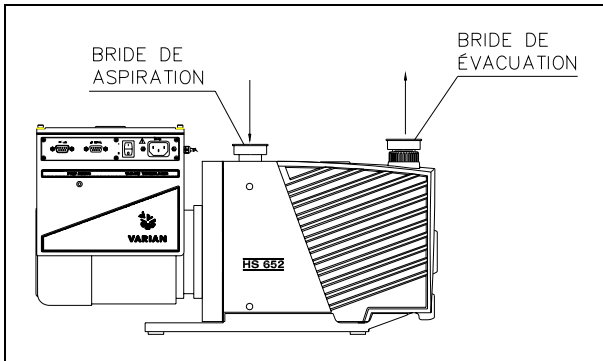

ATTENTION!

Contrôler que la tension d'alimentation correspond à la tension indiquée sur la plaquette du moteur.

Brancher la pompe à la source d'alimentation.

UTILISATION

Avant la mise en service de la pompe, il est nécessaire, pour atteindre le vide maximum, de faire fonctionner la pompe pendant environ une heure avec le reniflard ouvert afin de supprimer l'humidité de l'huile.

La mise en marche de la pompe ne requiert aucune manœuvre particulière ; il suffit de la brancher à l'alimentation électrique et d'agir sur l'interrupteur bipolaire (version avec moteur monophasé) ou unipolaire (version avec moteur triphasé).

DANGER!

La pompe a été conçue pour fonctionner avec des fluides neutres ou non corrosifs. L'emploi de substances potentiellement explosives ou inflammables est strictement interdit.

MAINTENANCE

Le personnel chargé de la conduite et de la maintenance de la pompe doit avoir reçu la formation nécessaire et posséder une connaissance approfondie des normes de prévention des accidents du travail.

DANGER!

Les hautes tensions peuvent entraîner la mort par contact. Veiller à toujours opérer avec le maximum de prudence et dans le respect des normes de prévention des accidents du travail en vigueur.

DANGER!

Lorsque la machine est sous alimentation, faire attention à la présence d'organes en mouvement et de haute tension.

DANGER!

En cas de nécessité de procéder à des opérations de maintenance de la pompe au terme d'une période de fonctionnement, il est indispensable de la laisser refroidir car sa température extérieure peut être supérieure à 60°C.

DANGER!

Avant toute opération de maintenance, il est impératif de toujours couper l'alimentation de la pompe. Placer les pancartes spécifiques d'avertissement : APPAREILLAGE EN COURS DE MAINTENANCE – NE PAS BRANCHER L'ALIMENTATION, près de l'interrupteur d'alimentation. Au terme des opérations de maintenance, restaurer les dispositifs de sécurité.

DANGER!

Ne pas effectuer la substitution d'huile immédiatement après l'arrêt de la machine car la température de cette dernière peut être élevée.

NOTE

Avant de retourner une pompe au constructeur pour réparation, il est indispensable de remplir et d'adresser au bureau local de vente la fiche "Sécurité et Santé" jointe à la présente notice d'instructions. Une copie de celle-ci devra être mise dans l'emballage de la pompe avant expédition.

En cas de mise au rebut de la pompe, procéder à son élimination conformément aux réglementations nationales en la matière.

MISE AU REBUT

Signification du logo "WEEE" figurant sur les étiquettes

Le symbole ci-dessous est appliqué conformément à la directive CE nommée "WEEE".

Ce symbole (**uniquement valide pour les pays de la Communauté européenne**) indique que le produit sur lequel il est appliqué NE doit PAS être mis au rebut avec les ordures ménagères ou les déchets industriels ordinaires, mais passer par un système de collecte sélective.

Après avoir vérifié les termes et conditions du contrat de vente, l'utilisateur final est donc prié de contacter le fournisseur du dispositif, maison mère ou revendeur, pour mettre en œuvre le processus de collecte et mise au rebut.

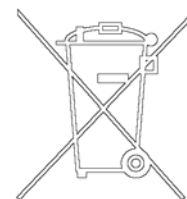

GENERAL INFORMATION

This equipment is destined for use by professionals. The user should read this instruction manual and any other additional information supplied by Varian before operating the equipment. Varian will not be held responsible for any events occurring due to non-compliance, even partial, with these instructions, improper use by untrained persons, non-authorized interference with the equipment or any action contrary to that provided for by specific national standards.

The HS452 and HS652 pumps are dual-stage, rotary vane pumps oil sealed, driven by a single-phase electric motor.

These high vacuum pumps are suitable for pumping non corrosive gases.

The following paragraphs contain all the information necessary to guarantee the safety of the operator when using the equipment. Detailed information is supplied in the appendix "Technical Information".

This manual uses the following standard protocol:



WARNING!

The warning messages are for attracting the attention of the operator to a particular procedure or practice which, if not followed correctly, could lead to serious injury.



CAUTION

The caution messages are displayed before procedures which, if not followed, could cause damage to the equipment.

NOTE

The notes contain important information taken from the text.

STORAGE

When transporting and storing the pumps, the following environmental requirements should not be exceeded:

- temperature: from -20° to +70 °C
- relative humidity: 0 - 95% (non-condensing)

PREPARATION FOR INSTALLATION

The pump is supplied in a special protective packing. If this shows signs of damage which may have occurred during transport, contact your local sales office.

Total weight of the pack, including the pump, is approx. 36 Kg. When unpacking the pump, be sure not to drop it and avoid any kind of sudden impact or shock vibration to it.

Do not dispose of the packing materials in an unauthorized manner. The material is 100% recyclable and complies with EEC Directive 85/399.

NOTE

Normal exposure to the environment cannot damage the pump. Nevertheless, it is advisable to keep it closed until it is installed in the system, thus preventing any form of pollution by dust.

NOTE

The pump is provided with some standard accessories:

- 1 oil bottle Varian GP
- 1 9 pin "D" connector for I/O (female)
- 1 9 pin "D" connector for RS232 (male)
- 1 fuse T10A

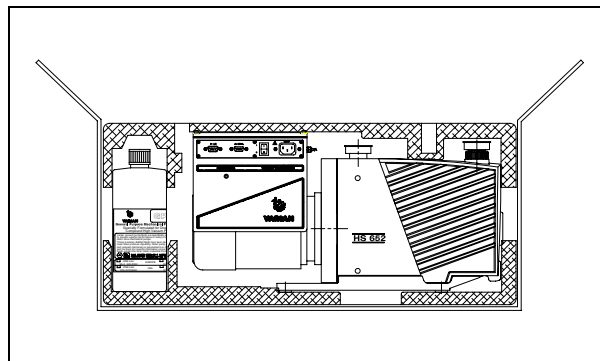

INSTALLATION

Do not install or use the pump in an environment exposed to atmospheric agents (rain, snow, ice), dust, aggressive gases, or in explosive environments or those with a high fire risk. During operation, the following environmental conditions must be respected:

- temperature: from +12 °C to +40 °C
- relative humidity: 0 - 95% (non-condensing)



WARNING!

Protect against short circuits and overload by installing on Varian Device electrical main line an automatic circuit breaker of proper capacity (see table here below):

P/N	110 Vac	220 Vac
949-9360	10 A	
949-9365		6 A



CAUTION

Before starting the pump, fill up with lubricating oil as the pump is delivered empty.



WARNING!

Take out the protective caps on the suction and exhaust flanges before doing anything else. In the event of an accidental start-up, the air inside the pump could violently expel the protective caps and harm the operator.



WARNING!

During installation, pay maximum attention that the suction flange is connected to the vacuum chamber and the exhaust flange is not closed (see the following figure).

The pump must not be used as a compressor. Maximum pressure inside the oil container must not exceed 1.5 bar (abs.)

Non-observance of these precautions may be dangerous for the machine and the operator.

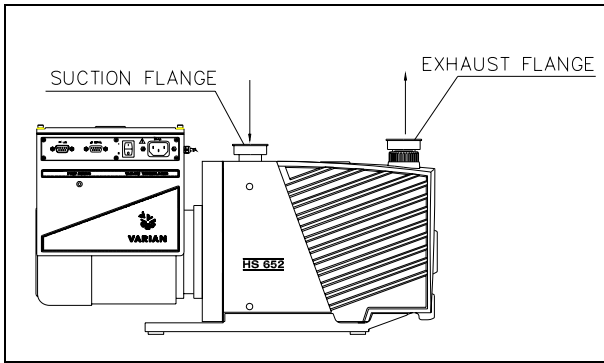

CAUTION

Check that your electrical mains voltage corresponds to that indicated on the motor's plate.

Connect the pump to the power supply.

USE

Before being put into service, in order to reach maximum vacuum, the pump must be left running for about an hour with the gas ballast valve open. This will eliminate any humidity from the oil.

There are no special procedures for switching the pump on; it needs only to be connected to the electric power by means of the bipolar switch.

WARNING!

The pump is designed for operation with neutral or non-corrosive fluids. It is absolutely forbidden to use potentially explosive or flammable substances.

MAINTENANCE

Personnel responsible for pump operation and maintenance must be well-trained and must be aware of the accident prevention rules.

WARNING!

Death may result from contact with high voltages. Always take extreme care and observe the accident prevention regulations in force.

WARNING!

When machine is powered take care on account of moving parts and high voltages.

WARNING!

If you have to perform maintenance on the pump after a considerable time in operation, leave it to cool as temperature of the outer surface may be in excess of 60 °C.

WARNING!

Always disconnect the power supply to the pump before starting maintenance work. Place a special warning signs over the power supply breaker switch: MACHINE UNDERGOING MAINTENANCE - DO NOT POWER ON. When finished, remove the safety warning.

WARNING!

Do not change the oil immediately after stopping the machine as the oil temperature may still be high.

NOTE

Before returning the pump to the constructor for repairs the "Health and Safety" sheet attached to this instruction manual must be filled-in and sent to the local sales office. A copy of the sheet must be inserted in the pump package before shipping.

If a pump is to be scrapped, it must be disposed of in accordance with the specific national standards.

DISPOSAL

Meaning of the "WEEE" logo found in labels

The following symbol is applied in accordance with the EC WEEE (Waste Electrical and Electronic Equipment) Directive.

This symbol (**valid only in countries of the European Community**) indicates that the product it applies to must NOT be disposed of together with ordinary domestic or industrial waste but must be sent to a differentiated waste collection system.

The end user is therefore invited to contact the supplier of the device, whether the Parent Company or a retailer, to initiate the collection and disposal process after checking the contractual terms and conditions of sale.

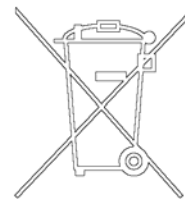

SECTION I

TECHNICAL DESCRIPTION

The HS452 and HS652 pumps are rotary vane pumps oil sealed, driven by a three-phase electric motor.

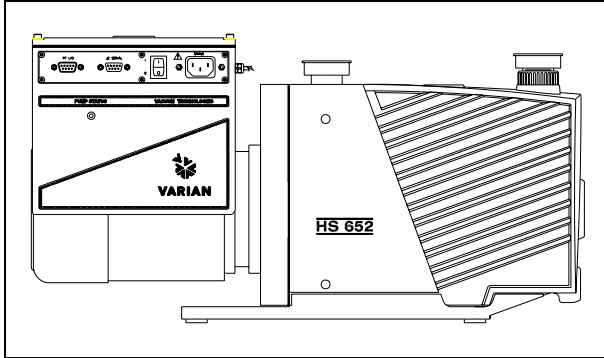

These vacuum pumps are suitable for pumping non corrosive gases.

The main features are:

- all parts in direct contact with the fluid pumped are free of copper alloys;
- all materials are carefully selected to provide extended life;
- a high capacity gas ballast device allow to pump condensable vapors;
- all the parts composing the pump are fully replaceable due to the close machining tolerances and to the centering obtained by using reference pins;
- due to its design features and low number of gaskets, the pump requires little maintenance, disassembly and reassemble are easy and require minimal time.

The pump works with force-feed lubrication, provided by an auxiliary gear-pump driven by the rotor of the vacuum pump itself. This ensures proper lubrication even when pressures are close to atmospheric.

The entire pump functional block is immersed in the oil contained in the casing. The oil guarantees perfect sealing of the discharge valves, enters the pump to ensure lubrication and sealing of the parts inside, facilitates heat dissipation and reduces pump noise.

The pump is equipped with a special anti-suckback device which automatically isolates the vacuum system when the pump stops. This avoids rises in pressure or oil flow in the vacuum system while air is allowed back into the stator chambers.

The air entering the pump after the anti-suckback device has closed prevents the oil in the casing from filling the stator chambers.

The inner seals are achieved by the lubricating oil, thanks to the close machining tolerances.

The vacuum pumps are connected directly to the electric motor through a flexible coupling, so that motion is transmitted even in case of poor alignment.

A fan fitted on the joint and housed in the pump support produces a forced air flow over the finned surfaces of the casing to avoid oil overheating.

LUBRICATION

The pump's lubricating system is force-feed type.

Oil circulation is obtained by means of a gear pump connected to the rotor shaft.

The oil is drawn through a gauze filter to prevent any foreign bodies from entering the pump.

Shunt-mounted on the delivery line is a hydraulic piston which, besides actuating the anti-suckback device (see *ANTI-SUCKBACK DEVICE*), also regulates pressure by discharging excess oil flow directly into the tank.

The required flow of oil under pressure passes through ducts that are drilled in the walls of the pump and lubricates the bushings and the inside parts.

VACUUM SEALS

A special feature of this pump is the low number of gaskets that are employed.

The seals in the circuit are obtained by means of VITON gaskets.

The careful surface finish of the various parts of the pump means that vacuum sealing of the functional block is ensured by the film of oil separating metal surfaces. Sealing of the rotor shaft is guaranteed by a rotating gasket with dust-guard lip.

The suction flange and duct are sealed by mean of OR gaskets.

GAS BALLAST VALVE

When the pump sucks in vapors, these condense during compression and mix with the oil, forming an emulsion (an aqueous vapor, for example) or a solution (organic solvent vapors, for example).

A number of problems arise from this, such as the impossibility of obtaining high vacuums, the alteration of the properties of the oil, could cause scaling on parts of the pump.

To avoid this, during compression at the second stage, atmospheric air is let into the pump through an adjustable valve, or "gas ballast valve", located at the top of the pump.

In this way, the discharge valve of the second stage opens through the effect of the atmospheric air before the partial pressure of the vapor reaches saturation point, thus preventing condensation from occurring. The vapors are expelled mixed with air.

ANTI-SUCKBACK DEVICE

The pump is equipped with a special anti-suckback device to avoid air pressure rises and/or oil backflow towards the evacuated vessel when the pump is switched off. This device has a shutter which automatically closes the suction duct.

In this way the pump and vacuum system are completely isolated from each other and air can enter the pump without any risk for the vacuum produced in the system.

The device includes some special features, namely:

- drive obtained avoiding any form of contamination of the inlet duct by fluids (oil and/or air) used to command the shutter. Thanks to this, when the pump is started again, the pump-down to vacuum conditions is extremely fast as these contaminants are not present and no degassing is therefore required;
- suction flange maintained closed even when the pump is idle, so that pollutants cannot enter from the environment and no oil can overflow from the pump.

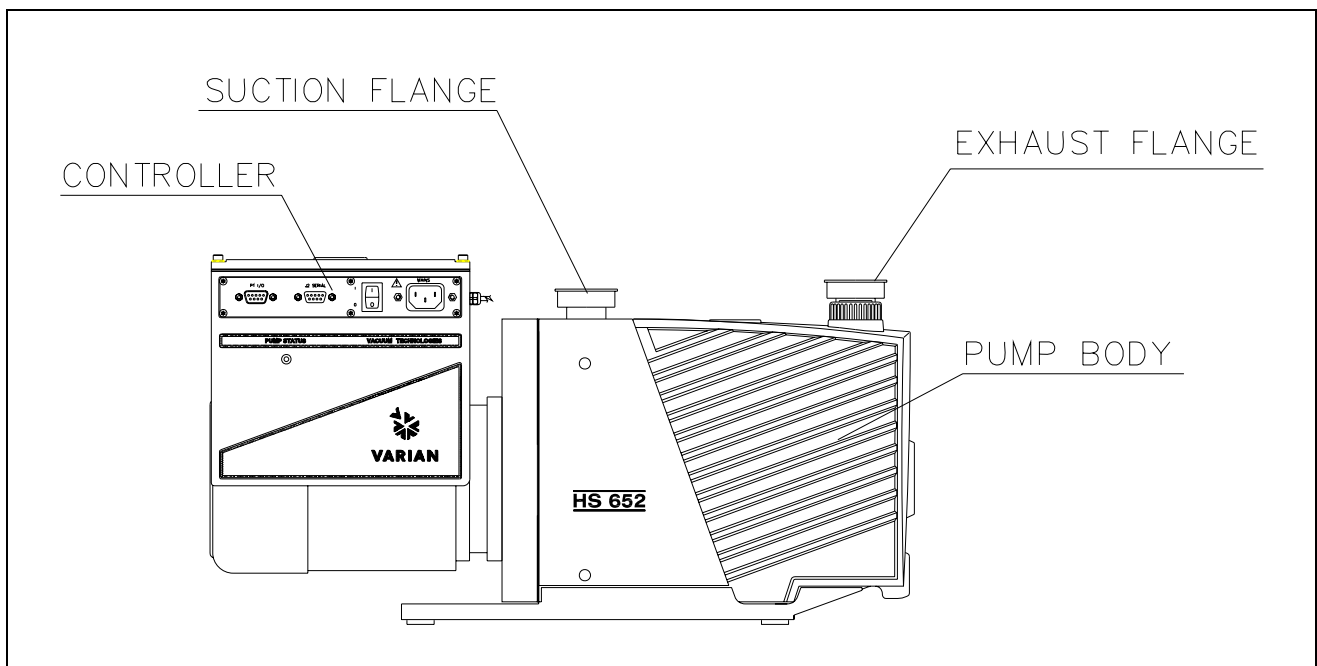

Pump main assemblies

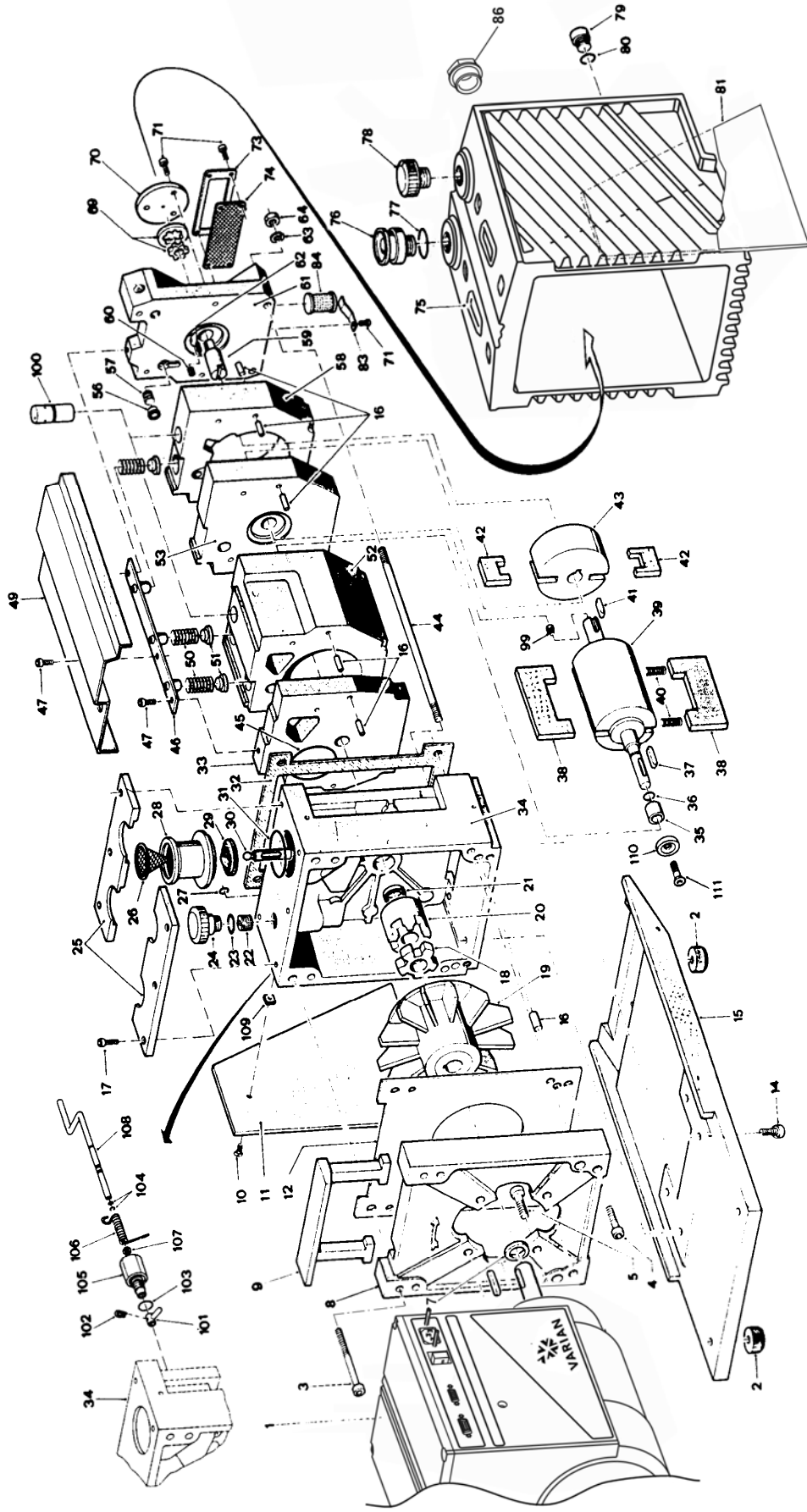

View of the pump

Legend (cf. figure *View of the pump*)

N°	Description	HS452-652
1	Inverter motor assy	SR03700703
2	Rubber foot	
3	Screw	
4	Screw	
5	Screw	
7	Spacer	
8	Motor support	
9	Handle	
10	Screw	
11	Right sideplate	
12	Board	
14	Screw	
15	Support plate	
16	Cylindrical pin	(1) - (2)
17	Screw	
18	Rubber crown	(1) - (2)
19	Half-joint with fan	
20	Half-joint (pump side)	
21	Oil-seal ring	(1) - (2)
22	Special screw	
23	OR gasket	(1) - (2)
24	Gas Ballast Valve knob	
25	Half-plate	
26	Inlet screen	SR03700237
27	OR gasket	(1) - (2)
28	Suction flange	
29	Anti-suckback shutter	(1) - (2)
30	Piston	
31	OR gasket	(1) - (2)
32	Casing gasket	(1) - (2)
33	Inner plate	SR03700362
34	Pump support	
35	Anti-wear bushing	SR03700370
36	OR gasket	(1) - (2)
37	Kei motor side	SR8999980301
38	First stage vane	(1)
39	First stage rotor	SR03700371
40	Spring	(1) - (2)
41	Tongue	SR8999980401
42	Second stage vane	(1)
43	Second stage rotor	SR03700367
44	Tie-rod	SR03700335
45	OR gasket	(1) - (2)
46	Bracket	
47	Screw	
49	Valve cover plate	
50	Valve spring	(1) - (2)
51	Valve gasket	(1) - (2)

N°	Description	HS452-652
52	First stage stator	SR03700419
53	Middle plate	SR03700421
56	GasBallast Valve shutter	(1) - (2)
57	GasBallast Valve spring	(1) - (2)
58	Second stage stator	SR03700364
59	Oil pump joint	SR03700390
60	Special screw	
61	End plate	SR03700391
62	Tongue	
63	Washer	
64	Nut	
69A	External oil pump gear	SR03700281
69B	Internal oil pump gear	SR03700277
70	Oil pump cover	
73	Plate	
74	Filter	
75	Casing	
76	Exhaust flange	
77	OR gasket	(1) - (2)
78	Oil fill plug	
79	Oil drain plug	SR03700256
80	Oil drain plug gasket	SR03700256
81	Left sideplate	
83	Spring	
84	Filter	
86	Oil level indicator	
99	Special screw	
100	Piston	
101	Arm	
102	Spring	(1)
103	OR gasket	(1) - (2)
104	OR gasket	(1) - (2)
105	Sleeve	
106	Spring	(1)
107	Ring	(1) - (2)
108	Arm	
109	Insert	
110	Special washer	
111	Screw	

NOTE

- (1) Part of Smart Pump Major Maintenance Kit (P/N 9499382)
- (2) Part of Smart Pump Minor Maintenance Kit (P/N 9499371)

TECHNICAL DATA

The following table lists the main technical data of the HS452 and HS652 pumps.

TECHNICAL DATA	Hz	UNITS	HS452	HS652
FREE AIR DISPLACEMENT	66	l/min (m ³ /h)	450 (27)	658 (39.5)
	46	l/min (m ³ /h)	327 (19.6)	478 (28.7)
PUMPING SPEED (at 5 mbar inlet pressure)	66	m ³ /h	21	29.5
	46	m ³ /h	14.5	20.5
ULTIMATE PARTIAL PRESSURE *		mbar	10 ⁻⁴	10 ⁻⁴
ULTIMATE TOTAL PRESSURE *		mbar	2·10 ⁻³	2·10 ⁻³
ULTIMATE TOTAL PRESSURE WITH GAS BALLAST *		mbar	1·10 ⁻²	1·10 ⁻²
WATER VAPOR TOLERANCE		mbar	30	30
WATER VAPOR CAPACITY		g/h	550	550
OIL CAPACITY min/max		l	0.6/1	0.6/1
MOTOR RATING 3ph		kW	0.5	0.5
NOMINAL ROTATION SPEED (low speed)	66	rpm	1980	1980
	46	rpm	1350	1350
NOISE LEVEL with gas ballast closed		dB(A)	≤ 60	≤ 60
OIL TEMPERATURE (pump operating) **		°C	75	75
		°F	169	169
Installation category	II			
Pollution degree	2			
OPERATING TEMPERATURE RANGE		°C	12 - 40	12 - 40
WEIGHT		Kg	33	33
		lb	72.7	72.7
INLET FLANGE		DN	25KF	25KF
EXHAUST FLANGE		DN	25KF	25KF
Main Dimensions:				
- length		mm	515	515
- width		mm	164	164
- height		mm	271	271
Nominal Input Voltage		V	100 – 120 200 - 240	100 – 120 200 - 240
Input frequency		Hz	50 - 60	50 – 60
Max input power		VA	1000	1000
Main Fuse (T type)		A	10	10

* According to PNEUROP 6602

** At ultimate total pressure, 20 °C (68 °F) room temperature

DIMENSIONS

The following figure shows the pump dimensions.

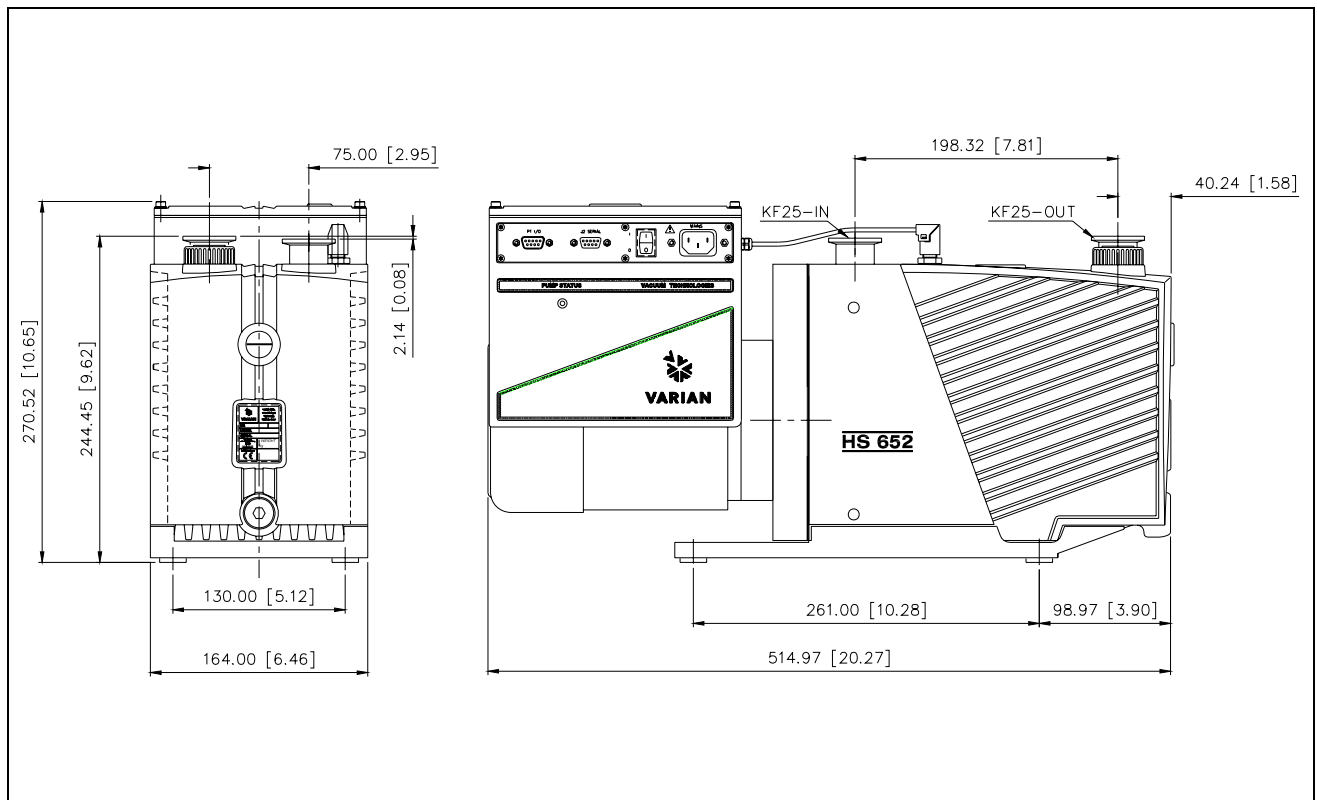

HS 452 and HS 652 pump dimensions

SAFETY PRECAUTIONS

- Always carry the pump by means of the handles provided.
- The pump must be set in position taking the utmost care in order to avoid accidental falls.



WARNING!

In case of a need to handle the pump after a period of operation, it must be left to cool first as the external surface temperature may be in excess of 60 °C.

TRANSPORT AND INSTALLATION

The pumps are shipped to the customer inside cardboard boxes.

Total weight of the pack, including the pump, is about 36 Kg.

The case must be handled with care, using appropriate lifting equipment.



CAUTION

When moving the case, ensure that it is securely bound to the lifting equipment and that the equipment is strong enough to support the weight.

The pump's working environment is a traditional industrial environment. Naturally sites with corrosive vapors or excessive heat are best avoided.

Room temperature should ideally be between 12 °C and 40 °C.

If the temperature is not inside this range, consult Varian technical service for the changes required.

Setting the pump in position should be performed as follows:

- Pump laid on the ground. There are no special instructions for this type of installation, except that the floor should be as flat as possible and suited to bear the weight of the pump (it should ideally be a concrete floor) and of any accessories mounted on it. Note that the pump is stable on its base plate and it should not be necessary to anchor it to the floor with bolts and screws; also vibrations to and from the pump are greatly reduced by the use of rubber feet.

- Pump off the ground. In this case, the user must design a suitable support structure, remembering the following points:

- * the plane supporting the pump must be perfectly horizontal;
- * the structure should be adequately rigid;
- * the relevant safety precautions should be applied.

Note also that the pump should be attached to the supporting structure after replacing the rubber feet with special anti-vibration feet, which should be screwed to the pump base and to the supporting plane.

After taking the pump out of its packing case, you are advised to make the following checks:

- a. Ensure that the pump has not suffered any damage during shipping.
- b. Check that there are no uncovered or loose parts.

PRELIMINARY OPERATIONS

Before starting the pump, fill up with lubricating oil as the pumps are delivered empty.

NOTE

A tin of oil is included in the packing.



CAUTION

Oil must be poured into the casing through the special threaded plughole and NOT through the suction line.



WARNING!

Take out the protective caps on the suction and exhaust flanges before doing anything else. In the event of an accidental start-up, the air inside the pump could violently expel the protective caps and harm the operator.

SECTION II
CONNECTION TO THE ELECTRIC SUPPLY

 **CAUTION**

It is recommended to connect the pump to the power supply through a dedicated switch on the main electrical panel of the installation, or in proximity of the power supply connection point.

CONNECTIONS TO THE INLET AND EXHAUST FLANGES

Remove the protective caps from both flanges. Connect the system to be evacuated to the inlet flange, using a centering ring with OR and a locking collar.

NOTE

For guaranteed reliable sealing, use an OR gasket in Perbunan or Viton.

The inlet duct is equipped with a sieve filter preventing solid particles from entering and damaging the pump.

NOTE

When the gases to be pumped out contain dust, it is advisable to insert a dust filter before the inlet flange.

NOTE

When the gases to be pumped out contain large quantities of vapor, it is advisable to include a condense separator before the inlet flange.

To make best use of the pump's capacity, use only short, straight piping, with a diameter not smaller than that of the inlet flange.

NOTE

If rigid piping is used, it is good practice to use a flexible joint in order to avoid undue forcing of the connection on the pump.

The exhaust duct must be connected to a pipe that will take away the pumped out gases.

NOTE

Application of an oil trap filter is necessary to avoid pollution of the surrounding atmosphere by the oil present in the exhaust duct during pump operation.

 **CAUTION**

Never block the pump exhaust line. This would cause overpressure in the casing with the risk of breaking the pumping block envelope.

STARTING AND RUNNING THE PUMP

Before being put into service, in order to reach maximum vacuum, the pump must be left running for about an hour with the gas ballast valve open. This will eliminate any humidity from the oil.

 **WARNING!**

The pump is designed for operation with neutral or non-corrosive fluids. It is absolutely forbidden to use potentially explosive or flammable substances.

NOTE

If the pump is started with cold oil, initially more than normal noise will be heard; this will last for a few minutes only until the oil reaches its working temperature.

There are no special instructions for normal operation of the pump, which is delivered to you after completion of a running-in cycle in the factory.

If the pump is sucking in environments with liquids or vapors, it is important to leave it to run with the gas ballast open so as to avoid condensation of the vapors and contamination of the lubricating oil as a result. When there is no danger of the oil being contaminated, the gas ballast valve should be closed to reduce the pump's power absorption.

The gas ballast valve will prove useful in the cold season when, due to the lower room temperatures, it takes longer for the pump to reach rated temperature when switched on. Compression of the air forced in by the gas ballast valve develops heat, which in turn increases temperature of the oil faster.

NOTE

If gases without vapors are sucked in, you are advised to open the gas ballast device from time to time in order to eliminate the traces of humidity they contain.

NOTE

For repetitive work cycles, with brief time intervals in between, it is better not to stop the pump.

STOPPING THE PUMP

There are no special procedures for switching the pump off; it needs only to be disconnected from the electric power by means of the bipolar switch.

When the pump is stopped, the anti-suckback device makes it possible to maintain vacuum in the vessel connected on the inlet flange of the pump.

If the pump is expected to be stopped for a lengthy period, or in any case if it has pumped in large amounts of vapors, it is good practice to run it with the gas ballast open and the inlet line closed for a few minutes before switching off in order to limit the risk of corrosion or scaling due to pollution of the oil by condensed vapors.

SAFETY RULES

Personnel responsible for pump operation and maintenance must be well-trained and must be aware of the accident prevention rules.

The accident prevention precautions contained in this section must be respected at all times during operation and maintenance of the pump to avoid damage to operators and to the pump.

These precautions are provided in the form of WARNING and CAUTION notes.



WARNING!

Operating procedures, technical information and precautions which, if not respected and/or implemented correctly may cause body harm to operators.



CAUTION

Operating procedures, technical information and precautions which, if not respected and/or implemented correctly may cause damage to the pump.

WARNING NOTES

- a. Death may result from contact with high voltages. Always take extreme care and observe the accident prevention regulations in force.
- b. Always disconnect the power supply to the pump before maintenance work. Place a special warning signs over the power supply breaker switch: MACHINE UNDERGOING MAINTENANCE - DO NOT POWER ON.
- c. If you are performing maintenance after the pump has been operating for a considerable time, allow sufficient time for it to cool as the external surface temperature may be in excess of 60 °C.
- d. Failure to provide the pump with an earth connection may cause serious damage to operators. Always ensure that there is an earth connection and that it complies with the standards.
- e. When cleaning the pump and its component parts, avoid the use of flammable or toxic solvents, such as benzin, benzol, ether or alcohol. The recommendation is to use a soap and water solution, preferably in ultrasound washing machines, taking care to dry all the cleaned parts at temperatures under 100 °C in order to eliminate residual moisture.
- f. Prolonged overloads or breakdowns may cause the electric motor to overheat, and to release noxious smoke; remove the power immediately as a precaution and do not approach the pump at least until you have provided ventilation to drive out the smoke. Take care not to breathe in the fumes remaining inside the pump in the course of repair work.
- g. In case of fire, do not throw water on the pump. Switch the power off and use CO₂ extinguishers.
- h. Carefully inspect the flanges to ensure that there are no dust, oil, dirt or defects of the mating surfaces, before making the required connections.
- i. Ensure that all joints and couplings are locked correctly before starting the pump again after repair work.
- j. Do not wear any objects that may become entangled in the mechanisms and/or act as conductors (chains, bracelets, etc.).
- k. Ensure that the tools to be used are in perfect working condition and have insulating grips, where necessary. Check that the insulating material of the cables and that the conductors of the test equipment do not show any signs of damage.

- l. Do not replace the oil immediately after stopping the machine as the oil may still be at high temperature.
- m. Perform repairs in clean and, where possible, dust-free areas. Protect all the clearances of connection points with suitable plastic caps and cover the machined surface areas of all parts stripped down until they are put back on the pump again.

CAUTION NOTES 

- a. Before putting the pump back into operation after a breakdown, inspect it and check carefully for any other signs of damage.
- b. Use only tools that are in perfect working order and specially designed for the job; use of inappropriate or ineffective tools may cause serious damage.
- c. Perform repairs in clean and, where possible, dust-free areas. Protect all the clearances of connection points with suitable plastic caps and cover the machined surface areas of all parts stripped down until they are put back on the pump again.
- d. Always check the lubricant and that it is properly distributed through the pump; inadequate lubrication may damage the pump seriously.
- e. Give the parts some form of marking as you strip them down to ensure that you reassemble them again in the proper order.
- f. Check that there are no scratches or grooves on the machined shafts, in their seats inside the pump or on machine-ground surfaces. Slight scratches and abrasions may be eliminated with very fine emery paper or by a little light grinding.
- g. Before putting a group together, always spread a little oil over inner parts and mating surfaces. Replace all seals with original spare parts before reassembling components.

MAINTENANCE ACTIONS

Maintenance may be seen as the totality of all scheduled and unscheduled maintenance work.

Maintenance includes:

1. **SCHEDULED MAINTENANCE:** Maintaining the nominal state of operation.
2. **UNSCHEDULED MAINTENANCE:** Restoring the nominal state of operation

NOTE

The frequency with which repairs are performed depends on the process and presence of substances that shorten pump life (dust, abrasives, solvents, water, chemically aggressive substances).

The pump must be cleaned at regular intervals of time.

 **CAUTION**

Do not clean with Alcohol the plastic or rubber components of the pump.

Use only the strictly necessary amount of lubricant; an excess of lubricating oil, like when there is none, may sometimes compromise proper operation of the pump.

Only the recommended lubricants, or lubricating oils with similar characteristics and known and experimented quality, should be used.

Oil changes must be made with the oil at a sufficiently high temperature, after leaving the pump to cool for a few minutes following operation.

The drain and filler plugs must not be left open any longer than is strictly necessary.

When performing maintenance, look out for all signals that may precede a breakdown, in particular:

- traces of corrosion;
- oil leaks;
- slack joints or couplings.

Maintenance technicians must:

- be aware of all applicable national directives concerning accident prevention during work on motor-driven pumps and should know how to apply them;
- have read and understood all the sections on "Safety Rules";
- be familiar with the essential design features and operation of the pump;
- know how to use and consult the pump documentation;
- be concerned about proper operation of the pump;
- make a note of any irregularities in operation of the pump and take the necessary action, where appropriate.

Use original spare parts wherever possible and repair a broken part as best as possible on site or send it back to the manufacturer for repairs.

For all problems arising, or to order spare parts, refer to our service department.

LUBRICANTS

It will be readily understood how important adequate lubrication is to high technology pumps like the Varian vacuum pumps. Correct use of appropriate lubricants makes a significant contribution to achieving best performance and warding off defects.

When handling lubricants, the following sanitary protection measures should be observed at all times:

- Avoid prolonged, excessive or repeated contact of the skin with products for lubrication, and also avoid directly inhaling the fumes or vapors of such products.
- Protect the skin by wearing appropriate clothes and equipment (e.g. special suits, glasses or, where permitted by the safety regulations, gloves) or by applying a special protective product.
- Clean the skin carefully after contact with the lubricants by washing freely with water and soap.
- Apply a skin cream after washing.
- Take off and change clothes or shoes on which oil has been spilled.
- Never put rags dripping with oil into the pockets of your clothes.

When disposing of waste lubricants, observe the following environment protection regulations:

- The lubricants risk contaminating the water and the ground! Therefore never pour lubricating products on to the ground, into water or in the sewage system. All violations of these rules are liable to persecution as provided for by law. When using lubricants always keep an oil can nearby.
- Take care in draining off waste oils. In disposal of these products respect all regulations in force concerning waste oil disposal.

The recommended lubricating oil is the Varian Rotary Vane Fluid DS19 Type. The Rotary Vane Fluid DS19 Type is a general purpose mechanical pump fluid specifically engineered to provide superior performance in high speed direct drive mechanical pumps.

These precisely distilled fluids (100% solvent refined neutral paraffinic oil) deliver lower base pressure capability, faster pump-down cycles, and reduced maintenance requirements on both the pump and the fluid.

It is absolutely necessary to continue using the lubricants initially used to fill the tank. If this is not possible for organizational or business reasons, use only products with the same characteristics as the previous oils.

Only use of lubricants of suitable quality will guarantee safe operation of the pumps.

 **CAUTION**

Mineral oils and the PFPE oil are incompatible. To change from one type to another, the pump must be stripped down completely and all parts washed carefully to eliminate all oil residues.

If you expect to have to use other lubricants, first find out if the two products are compatible. In cases of doubt, the lubricant used up to that time must be flushed out by way of a pump flushing procedure.

 **CAUTION**

To avoid the risk of contaminating the oil, absolute cleanliness of the pump and surrounding area must be ensured during the lubrication procedures.

Varian Rotary Vane Fluid DS19 Type characteristics

PROPERTY	UNIT OF MEASURE	ROTARY VANE FLUID DS19 Type
Vapor pressure @ 25 °C	Torr	1·10 ⁻⁵
Boiling point @ 0,01 torr	°C (°F)	112 (233)
Viscosity @ 40 °C	cSt (SUS)	55 (258)
Viscosity @ 100 °C	cSt (SUS)	8,1 (52,7)
Pour point	°C (°F)	-15 (5)
Flash point	°C (°F)	213 (415)
Fire point	°C (°F)	244 (472)
Density @ 25 °C	g/ml	0,87

Varian Rotary Vane Fluid DS19 Type vapor pressure curve

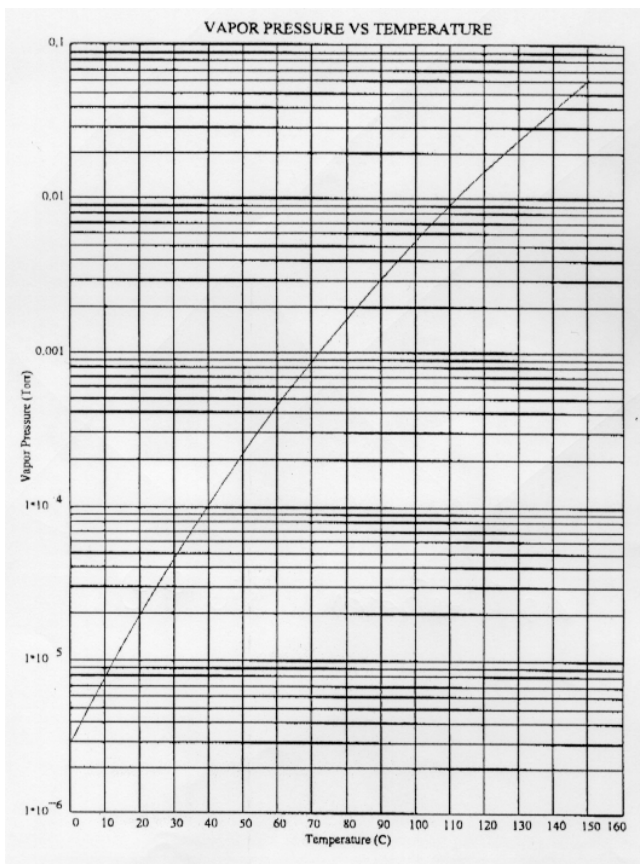

Varian Rotary Vane Fluid DS19 Type viscosity curve

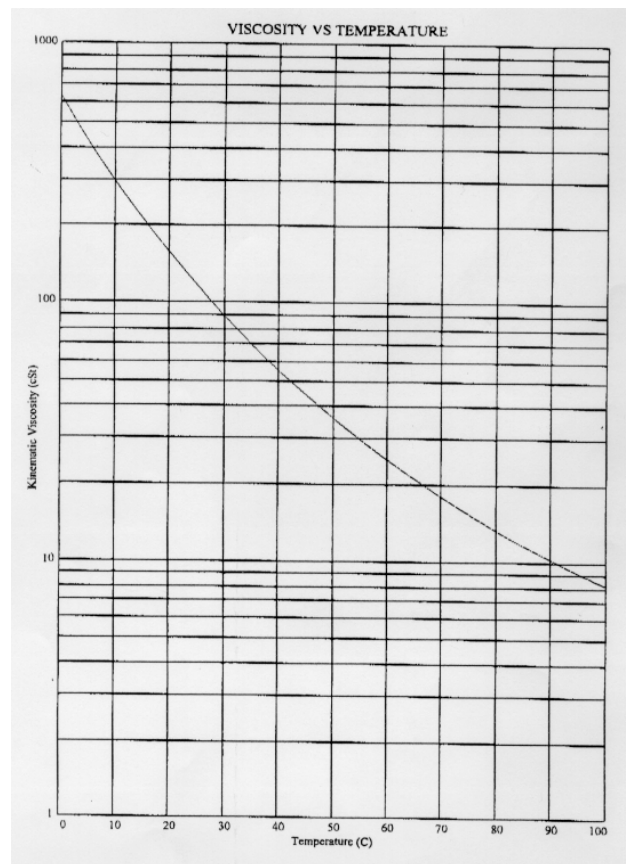

PUMP ELECTRONIC CONTROLLER

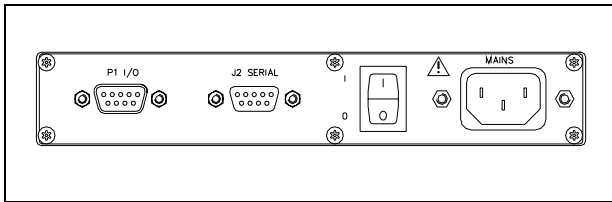

Technical specifications

- Input voltage: 100-120 V/50-60 Hz; 200 V-240 V/50-60 Hz
- Output voltage: 189 Vrms 3 ph; Max frequency: 68 Hz (factory setting)
- Starting phase maximum power: 780 W (maximum time: 15 min.)
- Normal Operation maximum power: 650 W
- Maximum room temperature: 40 °C
- Protection level: IP 44 (only using the accessory kit P/N 949-9367)
- CE mark:
 - EN55011 cat "B"
 - EN61000-3-2
 - EN61000-3-3
 - ESD EN61000-4-2
 - EN61000-4-3
 - EN6100-4-4
 - EN61000-4-5
 - RF EN61000-4-6
 - EN61000-4-8
 - EN61000-4-11
 - EN61010-1
- CSA mark:
 - EN61010-1, Installation category II, pollution degree 2
 - EN60950

Input/Output communications:

P1 – I/O

PIN N.	SIGNAL NAME	IN / OUT
1	Norm. Status (N.O. relay contact)	out
2	Speed setting (0-10V)	in
3	Oil level (relay contact)	out
4	Start (-)	in
5	Ground	out
6	Norm. Status (N.O. relay contact)	out
7	Oil level (relay contact)	out
8	Start (+)	in
9	24V	out

- Remote Start/Stop
- Rotational speed setting by analog input (0-10V):
 - High speed (68Hz): Vin>9V
 - Low speed (46Hz): Vin<1V

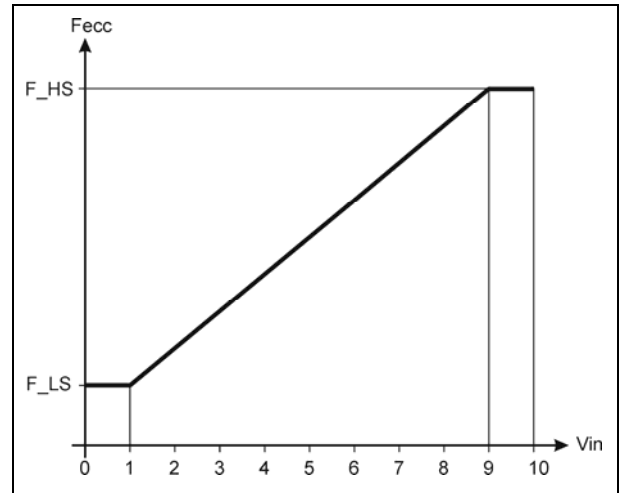

- frequency interlock (46Hz)

NOTE

The pump operation is I/O signals dependent so you must always plug-in the provided mating connector to start the pump.

RS 232/RS 485 COMMUNICATION DESCRIPTION

Both the RS 232 and the RS 485 interfaces are available on the connector J2

J2 – Serial Port

PIN N.	SIGNAL NAME
1	+ 5 V out
2	TX (RS232)
3	RX (RS232)
4	Spare
5	GND
6	A+ (RS485)
7	Spare
8	B- (RS485)
9	Spare

The communication protocol is the same (see the structure below), but only the RS 485 manages the address field. Therefore to enable the RS 485 is necessary to select the type of communication as

well as the device address by means of the T-plus software

NOTE

The RS-485 is a 2-wire (gnd optional) half-duplex communication link.

Communication Format

- Physical level: both RS232 e RS485
- 8 data bit
- no parity
- 1 stop bit
- baud rate: 600/1200/2400/4800/9600 programmable

Communication Protocol

The communication protocol is a MASTER/SLAVE type where:

- Host = MASTER
- Pump = SLAVE

The communication is performed in the following way:

1. the host (MASTER) send a MESSAGE + CRC to the controller (SLAVE);
2. the controller answer with an ANSWER + CRC to the host.

The MESSAGE is a string with the following format:

<STX>+<ADDR>+<WIN>+<COM>+<DATA>+<ETX>+<CRC>

where:

NOTE

When a data is indicated between two quotes ('...') it means that the indicated data is the corresponding ASCII character.

- <STX> (Start of transmission) = 0x02
- <ADDR> (Unit address) = 0x80 (for RS 232)
- <ADDR> (Unit address) = 0x80 + device number (0 to 31) (for RS 485)
- <WIN> (Window) = a string of 3 numeric character indicating the window number (from '000' to '999'); for the meaning of each window see the relevant paragraph.
- <COM> (Command) = 0x30 to read the window, 0x31 to write into the window
- <DATA> = an alphanumeric ASCII string with the data to be written into the window. In case of a reading command this field is not present. The field length is variable according to the data type as per the following table:

DATA TYPE	FIELD LENGTH	VALID CHARACTERS
Logic (L)	1	'0' = OFF '1' = ON
Numeric (N)	6	'-', '.', '0' ... '9' right justified with '0'
Alphanumeric (A)	10	from blank to '_' (ASCII)

- <ETX> (End of transmission) = 0x03
- <CRC> = XOR of all characters subsequent to <STX> and including the <ETX> terminator. The value is hexadecimal coded and indicated by two ASCII character.

The addressed SLAVE will respond with an ANSWER whose structure depends from the MESSAGE type.

When the MESSAGE is a reading command, the SLAVE will respond transmitting a string with the same structure of the MESSAGE.

The controller can answers with the following response types:

TYPE	LENGTH	VALUE	DESCRIPTION
Logic	1 byte	-	After a read instruction of a logic window
Numeric	6 bytes	-	After a read instruction of a numeric window
Alphanumeric	10 bytes	-	After a read instruction of an alphanumeric window
ACK	1 byte	(0x6)	The command execution has been successfully completed
NACK	1 byte	(0x15)	The command execution has been failed
Unknown Window	1 byte	(0x32)	The specified window in the command is not a valid window
Data Type Error	1 byte	(0x33)	The data type specified in the command (Logic, Numeric or Alphanumeric) is not accorded with the specified Window
Out of Range	1 byte	(0x34)	The value expressed during a write command is out of the range value of the specified window
Win Disabled	1 byte	(0x35)	The specified window is Read Only or temporarily disabled (some values cannot be changed while pump is running)

NOTE

Using the RS 485 interface, the message structure remains identical to the one used for the RS 232 interface, the only difference being that the value assigned to the ADDRESS <ADDR>

Examples:

Command: START

Source: PC

Destination: Pump

02	80	30	30	30	31	31	03	42	33
STX	ADDR	WINDOW			WR	ON	ETX	CRC	

Source: Pump

Destination: PC

02	80	06	03	38	35
STX	ADDR	ACK	ETX	CRC	

Command: STOP

Source: PC

Destination: Pump

02	80	30	30	30	31	30	03	42	32
STX	ADDR	WINDOW			WR	OFF	ETX	CRC	

Source: Pump

Destination: PC

02	80	06	03	38	35
STX	ADDR	ACK	ETX	CRC	

Command: READ PUMP STATUS

Source: PC

Destination: Pump (with address = 3)

02	83	32	30	35	30	03	38	37
STX	ADDR	WINDOW			RD	ETX	CRC	

Source: Pump (with address = 3 in stop status)

Destination: PC

02	83	32	30	35	30	30	30	30	30	03	38	37
STX	ADDR	WINDOW			DATA (STATUS)					ETX	CRC	

Windows meaning

WIN	TYPE	DESCRIPTION
000	L	START/STOP (1=START; 0=STOP)
001	L	LOW SPEED [0=OFF / 1=ON]
008	L	REMOTE/SERIAL CONFIGURATION (1=REMOTE; 0=SERIAL)
102	N	SET POINT VALUE (Hz)
105	N	SET POINT HYSTERESIS (%) [0-100]
108	N	BAUD RATE (0-4) [600-1200-2400-4200-9600]
117	N	LOW SPEED ADJUST (Hz)
120	N	ROTATIONAL FREQUENCY SETTING [Hz] (High speed adjust)
200	N	BUS CURRENT [mA]
201	N	3PHASE VOLTAGE [Vrms]
202	N	POWER [W]
203	N	DRIVING FREQUENCY [Hz]: (current driving frequency)
205	N	STATUS [0=stop ; 2=ramp ; 3=autotuning ; 5=normal ; 6=fail]
206	N	ERROR CODE Bit 7: motor block; Bit 6: short circuit; Bit 5: undervoltage; Bit 4: motor over temperature; Bit 3: power fail; Bit 2: controller overt; Bit 1: pump overt; Bit 0: spare
211	N	CONTROLLER TEMPERATURE [°C]
216	N	ENVIROMENT TEMPERATURE [°C]
300	N	CYCLE TIME [min]
301	N	CYCLE NUMBER
302	N	PUMP LIFE [h]
319	A	CONTROLLER MODEL
323	A	CONTROLLER SERIAL NUMBER
325	A	ELECTRICAL MODIFICATION LEVEL
500	L	Monitor Mode (write only)
503	N	RS485 SERIAL ADDRESS SETTING [0-31]
504	L	SERIAL TYPE SELECT (0=RS323; 1=RS485)

Operational limits:

INPUT VOLTAGE (V)	CONTROLLER STATUS
< 85	Power fail
85 – 140	Operative
140 – 170	Power fail
170 – 270	Operative
> 270	Power fail

Status Led

LED STATUS	CONTROLLER STATUS
Off	Stop
Green flashing	Ramp – Autotuning
Green	Normal Operation
Red	Fail
Slow red flashing (2 Hz)	Oil level fail
Quick red flashing (10 Hz)	Oil level sensor fail
Orange + Off	Reset + selftest

NOTE:

When you switch the controller on an electronic self-test is performed, during such phase you'll see the led Orange for 1 sec. And turned off for two other seconds.

Immediately after the first phase the controller perform a specific test on the pump rotor in order to be sure that it isn't locked.

Electronic self-test

When you switch the pump on with the main On/Off switch the pump doesn't start immediately but it start only after about three seconds.

This test time isn't required if the pump is already powered as when it is operated in remote or serial mode.

Rotor lock test

After the electronic self-test the inverter perform a rotor lock test. This test requires about 5 seconds. During this time the rotor turns very slowly; afterwards the pump accelerate. The acceleration time is a function of the oil temperature and of the chamber volume to rough down. The lower is the oil temperature the longer is the time required to reach nominal speed.

Oil level check

An oil level check is performed four minutes after the pump starting.

If the pump oil level is under the minimum threshold the pump controller generate a message you are able to receive by status led blinking (see the Status Led table), RS232 window (see Windows Meaning table) and a signal on I/O port (see I/O table).

NOTE

If the oil level check fails (low level) the pump doesn't stop. The test only activates the output described above.

An Oil level sensor fail is highlighted by means of quick status led blinking and RS232 window (see "Status led" and "Window meaning" tables).

IP44 ACCESSORY KIT P/N 949-9367

Using the IP44 accessory kit you can make the pump protected against solid and liquids as defined here below:

Protection against solids

- Protection against accidental touch of parts under power or internal moving parts with tools, wires, or similar objects with a size larger than 1mm.
- Protected against intrusion of parts larger than 1mm.

Protection against liquids

Water spray from all directions has no negative effect on the device.

IP44 Accessory kit items

- 1 main plug bracket
- 2 bracket spacers
- 2 bracket screws/washers
- 1 socket rubber gasket
- 2 IP44 plastic shells for 9 pin "D" mating connector.

IP44 Accessory kit use

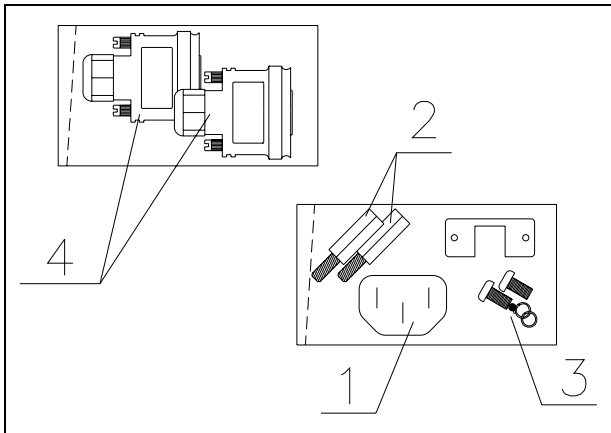

1. Remove the spring bracket mounted on standard IEC socket.
2. Insert the "D" rubber plate (item 1) into the pump's IEC main socket pushing it till the socket bottom.
3. Screw down the two brackets spacers (items 2) on the standard IEC socket spacers
4. Insert the main cable plug.
5. Fix the main cable plug by using the bracket and screws/washers (item 3).
6. Exchange the 9 pin "D" mating connector plastic shells with the IP44 shells (items 4) contained in the IP44 accessory kit (see the following figure).

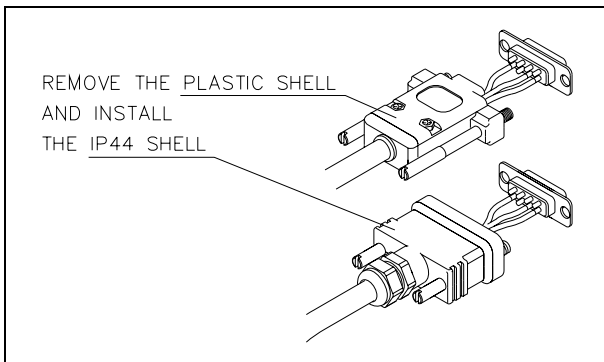

WARNING!

To obtain the IP44 protection level you must set up the pump electrical connections as highlighted in the following figure.

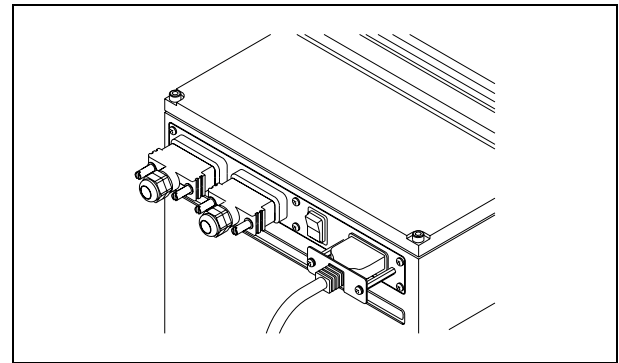

NOTE

You must exchange the 9 pin "D" mating connector shells with the IP44 version even if you have no cable wired on the connector. In that case you have to use the plastic cap as showed in the following figure.

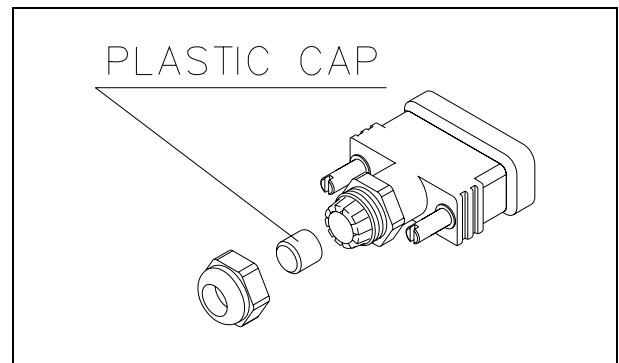

ACCESSORIES

PART NUMBER	DESCRIPTION
949-9390	Rotary Vane Fluid DS19 Type 1 L. bottle
949-9395	Smart Pump Oil mist eliminator
949-9392	Smart Pump Exhaust filter
949-9376	Smart Pump Oil return kit
949-9382	Smart Pump major maintenance kit
949-9371	Smart Pump minor maintenance kit
949-9367	Smart Pump IP44 accessory kit
949-9396	Power cable EU
949-9397	Power cable US
949-9398	Power cable UK
949-9399	Power cable IEC320

Request for Return



1. A Return Authorization Number (RA#) **WILL NOT** be issued until this Request for Return is completely filled out, signed and returned to Varian Customer Service.
2. Return shipments shall be made in compliance with local and international **Shipping Regulations** (IATA, DOT, UN).
3. The customer is expected to take the following actions to ensure the **Safety** of workers at Varian: (a) Drain any oils or other liquids, (b) Purge or flush all gasses, (c) Wipe off any excess residues in or on the equipment, (d) Package the equipment to prevent shipping damage, (for Advance Exchanges please use packing material from replacement unit).
4. Make sure the shipping documents clearly show the RA# and then return the package to the Varian location nearest you.

CUSTOMER INFORMATION

Company name:		Contact person:	
Name:	Tel:	E-Mail:	
Ship Method:	Shipping Collect #:	P.O.#:	
<u>Europe only</u> : VAT reg. Number:		<u>USA only</u> : <input type="checkbox"/> Taxable <input type="checkbox"/> Non-taxable	
Customer Ship To:		Customer Bill To:	
.....		
.....		

PRODUCT IDENTIFICATION

Product Description	Varian P/N	Varian S/N	Purchase Reference

TYPE OF RETURN (check appropriate box)

<input type="checkbox"/> Paid Exchange	<input type="checkbox"/> Paid Repair	<input type="checkbox"/> Warranty Exchange	<input type="checkbox"/> Warranty Repair	<input type="checkbox"/> Loaner Return
<input type="checkbox"/> Credit	<input type="checkbox"/> Shipping Error	<input type="checkbox"/> Evaluation Return	<input type="checkbox"/> Calibration	<input type="checkbox"/> Other

HEALTH and SAFETY CERTIFICATION

Varian Vacuum Technologies **CAN NOT ACCEPT** any equipment which contains **BIOLOGICAL HAZARDS** or **RADIOACTIVITY**. Call Varian Customer Service to discuss alternatives if this requirement presents a problem.

The equipment listed above (check one):

HAS NOT been exposed to any toxic or hazardous materials

OR

HAS been exposed to any toxic or hazardous materials. In case of this selection, check boxes for any materials that equipment was exposed to, check all categories that apply:

Toxic Corrosive Reactive Flammable Explosive Biological Radioactive

List all toxic or hazardous materials. Include product name, chemical name and chemical symbol or formula.

.....

Print Name: Customer Authorized Signature:

Print Title: Date:/...../.....

NOTE: If a product is received at Varian which is contaminated with a toxic or hazardous material that was not disclosed, **the customer will be held responsible** for all costs incurred to ensure the safe handling of the product, and **is liable** for any harm or injury to Varian employees as well as to any third party occurring as a result of exposure to toxic or hazardous materials present in the product.

Do not write below this line

Notification (RA)#: Customer ID#: Equipment #:

Request for Return



FAILURE REPORT

TURBO PUMPS and TURBOCONTROLLERS

<input type="checkbox"/> Does not start <input type="checkbox"/> Does not spin freely <input type="checkbox"/> Does not reach full speed <input type="checkbox"/> Mechanical Contact <input type="checkbox"/> Cooling defective	<input type="checkbox"/> Noise <input type="checkbox"/> Vibrations <input type="checkbox"/> Leak <input type="checkbox"/> Overtemperature	POSITION <input type="checkbox"/> Vertical <input type="checkbox"/> Horizontal <input type="checkbox"/> Upside-down <input type="checkbox"/> Other:	PARAMETERS Power: Rotational Speed: Current: Inlet Pressure: Temp 1: Foreline Pressure: Temp 2: Purge flow: <hr/> OPERATION TIME:
TURBOCONTROLLER ERROR MESSAGE:			

ION PUMPS/CONTROLLERS

<input type="checkbox"/> Bad feedthrough <input type="checkbox"/> Vacuum leak <input type="checkbox"/> Error code on display	<input type="checkbox"/> Poor vacuum <input type="checkbox"/> High voltage problem <input type="checkbox"/> Other
Customer application:	

VALVES/COMPONENTS

<input type="checkbox"/> Main seal leak <input type="checkbox"/> Solenoid failure <input type="checkbox"/> Damaged sealing area	<input type="checkbox"/> Bellows leak <input type="checkbox"/> Damaged flange <input type="checkbox"/> Other
Customer application:	

LEAK DETECTORS

<input type="checkbox"/> Cannot calibrate <input type="checkbox"/> Vacuum system unstable <input type="checkbox"/> Failed to start	<input type="checkbox"/> No zero/high background <input type="checkbox"/> Cannot reach test mode <input type="checkbox"/> Other
Customer application:	

INSTRUMENTS

<input type="checkbox"/> Gauge tube not working <input type="checkbox"/> Communication failure <input type="checkbox"/> Error code on display	<input type="checkbox"/> Display problem <input type="checkbox"/> Degas not working <input type="checkbox"/> Other
Customer application:	

PRIMARY PUMPS

<input type="checkbox"/> Pump doesn't start <input type="checkbox"/> Doesn't reach vacuum <input type="checkbox"/> Pump seized	<input type="checkbox"/> Noisy pump (describe) <input type="checkbox"/> Over temperature <input type="checkbox"/> Other
Customer application:	

DIFFUSION PUMPS

<input type="checkbox"/> Heater failure <input type="checkbox"/> Doesn't reach vacuum <input type="checkbox"/> Vacuum leak	<input type="checkbox"/> Electrical problem <input type="checkbox"/> Cooling coil damage <input type="checkbox"/> Other
Customer application:	

FAILURE DESCRIPTION

(Please describe in detail the nature of the malfunction to assist us in performing failure analysis):

NOTA: Su richiesta questo documento è disponibile anche in Tedesco, Italiano e Francese.

REMARQUE : Sur demande ce document est également disponible en allemand, italien et français.

HINWEIS: Auf Anfrage ist diese Unterlage auch auf Deutsch, Italienisch und Französisch erhältlich.