

Varian Mechanical Vacuum Pumps

Chemtech Scientific provides access to this content as a courtesy.
We do not own the content contained in this document.
All rights and credit go directly to its rightful owners.
www.chemtechsci.com
Call us at: 484-424-9415



Instruction Manual

MAJOR MAINT KIT COSTS \$285.00

SD 300

CONTENTS

	Page No.
I. TECHNICAL CHARACTERISTICS	3
II. OPERATION	4
2.1 Description	
2.2 First starting	
2.3 Normal starting	
2.4 Inlet connections	
2.5 Manual gas ballast valve	
2.6 Outlet	
III. MAINTENANCE	6
3.1 Draining of the oil	
3.2 Flushing	
3.3 Dismantling	
3.4 Re-assembly	
3.5 Ordering spare parts	
3.6 Tools	
IV. ADDENDA	12
4.1 Mist eliminator	
4.2 Automatic gas ballast	

I. TECHNICAL CHARACTERISTICS

Most parts of the "Chemical pumps" have been specially protected against corrosion either by metallic or by plastic coating. This protection enables VARIAN CD-300 pumps to resist corrosive gas attacks.

VARIAN CD-300 vacuum pumps are equipped with 3-phase motors 220 V/380 V, 50 Hz, or single-phase motors 220V, 50/60 Hz.

VARIAN CD-300 vacuum pumps for the USA are equipped with 3-phase motors 220/440-60 Hz, or single-phase motors 115/230 V, 60 Hz.

	50 Hz	60 Hz
Vaned pump stages	2	2
Nominal rotational speed	1500 t/min	1800 RPM
Free air displacement	15.7 m ³ /h	18.8 m ³ /h (11.1 CFM)
Air displacement Pneurop method	12 m ³ /h	15 m ³ /h (8-8 C)
(1) Base pressure (without gas ballast)	<1.10 ⁻⁴ mbar / 7.5 x 10 ⁻⁵ Torr	
Oil capacity l/qts	0.8 liter / 0.85 qts	
Power rate	0.37 kW (1/2 HP)	
Weight three-phase kg/lbs	22 kg / 48.4 lbs	
Weight single-phase	26.5 kg / 58.3 lbs	
Inlet pneurop flange	NW 25	
Outlet pneurop flange	NW 25	

(1) Partial pressure measurement
with LN₂ trapped Mac leod gauge

The above characteristics are obtained with VARIAN OIL GP.
They may vary when using other oil brands.

II. OPERATION

2.1 DESCRIPTION

Figure 01 shows a schematic cross-section and a side-view of the pump unit.

- A. Pumping section: mechanical, 2-vane, 1-stage pump
- B. Transmission: coupling and cooling fan
- C. Drive motor
- E. Inlet
- F. Oil filter plug
- G. Oil level sight glass
- H. Oil drain plug
- I. Gas ballast valve
- K. Outlet

2.2 FIRST STARTING

- Remove the protective caps from the inlet and outlet pipes.
- Connect the motor, after checking the supply voltage.

THREE-PHASE MODELS

Connect the terminals in the terminal box as shown in the diagram reproduced inside the lid, for 220 V or 380 V (50 Hz), 220 V or 440 V (60 Hz), as required.

The pumps are delivered with the motor connected for the max. voltage in Europe and min. voltage in U.S.

- Momentarily apply power and check the direction of rotation of the motor. The end of the shaft must turn in the direction of the arrow on the frame.

SINGLE-PHASE MODELS

The pump is delivered with a 2 meter long cord (2 wires plus ground). Wiring is for 220 V operation (50 Hz) or 115/230 operation (60 Hz).

The rotation direction is set at the factory.

- Motor protection for the rated current should preferably be provided.
- Unscrew the oil filler plug and fill to the middle of the sight glass. This operation should be carried out with the pump off.
- It is quite normal for the level to vary when the pump is rotating. Oil level is always checked with pump at rest!
- We recommend to use VARIAN OIL GP in our vacuum pumps (see characteristics page 3). However any of the following oils may be used:
SHELL TALPA 30 oil / ANTAR PV 600 oil / CODITEC PV 195 A oil.

Degradation of low vapour pressure oil characteristics may occur, if a pump is continuously run at high inlet pressure, or used for fast evacuation of a tank in close repeat cycles. This degradation is caused by excessive temperature rise. In certain cases, a charcoal deposition is noticed on the pump body.

For these tough applications, we recommend to use a synthetic oil, such as VARIAN OIL HT. Base pressure will increase a little bit, due to higher vapour pressure of this oil.

- Install the pump in the system and switch it on.
- The pump can be stopped without introducing air, as it is airtight and oil migration is controlled by anti-suckback valve.

2.3 NORMAL STARTING

Since the pump is airtight, no precautions need be taken on "cold starts", provided that the temperature is not below 10° C (40° F).

2.4 INLET CONNECTION

The pump inlet port is equipped with an ISO NW 25 flanged pipe. Connection of different nipples or fittings is secured by quick connect clamp.

For accessories, see VARIAN catalogues: vacuum fittings, high vacuum valves ...

2.5 GAS BALLAST VALVE

When pumping condensable vapours, open the gas ballast valve by opening the knurled knob (I in fig. 01) counter-clockwise.

If the pump has absorbed a considerable amount of condensable vapours, the condensate may become emulsified with the pump oil. In this case, it is merely necessary to close the inlet and run the pump by itself with the gas ballast valve fully open for approx. 30 min., to regenerate the oil (see 3-2).

2.6 EXHAUST OF PUMPED GASES

The exhaust port of the pump is equipped with an ISO NW 25 flanged pipe. To pump out the oil mist delivered when the pump is working at high pressure a hose nipple can be connected to this flanged pipe (see 2.4). An oil mist eliminator can also be fitted on the outlet.

III. MAINTENANCE

3.1 DRAINING THE OIL

The quality of the pump oil is extremely important for proper operation. The vacuum pump oil must be inspected periodically for contaminants and oil level which must be maintained in the center of the sight glass. Oil level is checked with the pump not rotating because the level will vary during operation. VARIAN pumps may be turned off for visual oil level inspection, while backing diffusion pumps, etc., as they seal under vacuum when turned off. The oil consumption, due to exhausting gases, will depend upon frequency of pump down and operating pressure.

VARIAN Exhaust Mist Eliminators will reduce loss considerably by condensing expelled oil vapours, and returning the oil to the reservoir.

Inspection of the oil level will also indicate oil contamination. The oil should have a light amber color. If brownish in color, the oil should be changed. Another indication of oil contamination is an increase in base pressure of the pump. VARIAN pumps are equipped with gas ballast, which can be used to regenerate oil contaminated with condensable vapours. The oil will be cloudy with a high base pressure. In this case, close the inlet and open the gas ballast valve for approximately thirty (30) minutes. The base pressure should reduce to a normal value after closing the gas ballast valve.

3.2 FLUSHING

If the base pressure is still high, an oil change must be performed. The oil should be drained when hot and discarded. When the oil has drained, vent the intake and run the pump for several seconds to expel oil trapped inside the pump stages. Re-charge with fresh clean oil through the fill plug, to the middle of the sight glass.

In some extreme cases, deposits have built up inside the pump so that new oil is contaminated within a few hours. In this case, the flushing procedure should be performed, as detailed here.

Drain oil from hot pump and re-install the drain plug. Place a cloth lightly over the exhaust port to contain oil splash. Turn the pump on, with inlet open and slowly pour fresh oil into the inlet - equal to the pump's capacity. Turn off pump and drain flushing oil. Re-charge oil level to middle of sight glass by way of the oil fill plug. VARIAN OIL GP is recommended for re-charging or flushing VARIAN vacuum pumps.

The cleanliness of the oil will greatly prolong the life and performance of the pump. A blank statement for oil changes cannot be made for all applications, due to the differences in operating conditions.

A general rule is the oil change every 2 to 3 months in clean applications; i.e. diffusion fore pump on UHV systems.

Extreme applications, such as ion implantation, chemical stripping or etching systems could require weekly maintenance oil changes or expensive trapping techniques.

3.3 DISMANTLING

The only regular maintenance required by our pumps is changing the oil or flushing. However, prolonged absorption of dust or acid-vapour-laden gases may produce clogging which can no longer be removed by flushing out with oil.

In that event the pump must be dismantled and all parts, except gaskets and seals, washed in trichloroethylene, or perchloroethylene.

VARIAN pumps are designed for easy dismantling, and few adjustments are required on re-assembly. All parts whose relative positions must remain constant are doweled after accurate setting at the factory, and on re-assembly the various parts will always be located in their correct positions by merely tightening the screws and nuts.

The only tools required are a few wrenches, which will generally form part of the standard equipment of any maintenance department.

Before dismantling the pump, drain the oil (see section 3.1). The first step of dismantling (fig. 02) is to remove the pumping section from its chamber. The second step is to dismantle the pumping section (fig. 03).

3.3.1 DISMANTLING OF THE MOTOR-PUMP SECTION (fig. 02)

- For easy dismantling place the pump vertically, motor uppermost.
- Unscrew the four handle plate fixing nuts 949-0712-11.
- Pull out the handle plate 949-0525-47 together with the motor. Be careful not to damage the flat gasket 949-0525-55. One half of the coupling assembly remains on the pump side (fan), the other one comes out on the motor shaft. The pumps equipped with an American made motor have an adaptor flange 949-0525-89 mounted between the handle plate and the motor.
- Remove the oil casing being careful not to damage the flat gasket 949-0527-55
- Unscrew the inlet-outlet flange fixing screw 949-0827-34 and remove the flange 949-0528-28.
- Remove the inlet port 949-0525-94, the filter 949-0525-65 and the outlet port 949-0527-54

3.3.2 DISMANTLING OF THE PUMPING SECTION (fig. 02 + 03)

Before dismantling, carefully note the positions of the bearing plates and the stators. These are precision-located on the bearing plates on assembly at the factory, and must be replaced in the same positions on re-assembly in order not to damage the dowel pin holes. Note part numbers.

- Remove the cover 949-0526-56 by unscrewing the two fixing screws 949-0755-76.
- Remove the valve springs 949-0525-41 and the valves 949-0526-42
- Remove the pump base 949-0525-21 by unscrewing the two set screws 949-0755-14.
- Put the pump upside down then turn the fan by hand and unscrew the shaft key set screw 949-0750-34.
- Remove the fan coupling 949-0525-52 and the key 949-0836-49.
- Place the pump vertically. Remove the impeller 949-0527-21 which is fixed on the shaft by means of circlip 949-0711-61. There is no need to remove the valve lever assembly 949-0527-00.

a) Removal of the rear bearing plate 949-0526-87

- Unscrew the three nuts 949-0712-24.
- Insert two screwdrivers into the slots at 180° to each other. Turn them about their axis to release the bearing plate from its doweling pins.
- Pull out the plate along its axis, being careful not to damage the shaft seal lips 949-0820-63. Remove the o-ring 949-0820-33.
The anti-suckback system is set at the factory. If dismantled, it must be reset as described under "re-assembly". However, the rear bearing plate can be removed without disturbing the setting of the sealing system.

b) Removal of the high pressure rotor 949-0527-15

- Make it slide along the double bore of the stator.
- Remove the vanes 949-0839-46 and the springs 949-0530-40.

c) Removal of the high pressure stator 949-0527-11

- Use two screwdrivers as indicated hereabove (a).
- Remove the o-ring 949-0820-33.

d) Removal of the central bearing plate 949-0526-50

- Use two screwdrivers as indicated hereabove (a).
- Remove the o-ring 949-0820-33.

e) Removal of the low pressure rotor 949-0525-33

- Remove the rotor 949-0525-33 by sliding along the double bore of the stator, being careful not to turn it.
- Remove the vanes 949-0839-45 and their springs 949-0530-40.

f) Removal of the low pressure stator 949-0525-74

- Use two screwdrivers as indicated above (a).
- Remove the o-ring 949-0820-33.

g) Removal of the front bearing plate 949-0525-75

- Use two screwdrivers as described above (a).
- Remove the spring 949-0525-64 and the gas ballast ball 949-0825-22.
- Remove the o-rings 949-0820-33 and 949-0820-56.

h) Removal of the gas ballast

- Unscrew the screw 949-0525-60
- Remove the knob 949-0525-59, the piston 949-0525-61, the spring 949-0525-63 and the seal 949-0525-62.

i) Oil circulation

The pumps are lubricated by means of an oil bath, the oil being taken from below the anti-suckback valve mounted on lever 949-0527-50

The oil flow is controlled by the seat of the plate 949-0527-17 on the two-stage pumps, the first stage is lubricated by oil passing through a bore in the intermediate plate.

The oil flow is controlled by a jet 949-0534-74.

Dismantling this jet for cleaning is not recommended; it is merely necessary to check that it is not blocked by blowing through with compressed air.

3.3.3 CLEANING OF PARTS AND REPLACEMENT OF GASKETS

a) Cleaning

All metal parts must be cleaned with trichloroethylene, using a brush. Rags and cloths must on no account be used.

Gaskets must not come into contact with trichloroethylene.

b) Replacement of gaskets

Check that the gaskets are in good condition and replace as required. (It is recommended that they be changed each time the pumping section is dismantled). Ask for our minor maintenance kit (see below).

3.4 RE-ASSEMBLY

Before re-assembly, dry all parts cleaned with trichloroethylene by means of compressed air. Re-assembly must be carried out in the exact reverse order of the dismantling operations, noting however the following points:

- a) All the metallic parts and the lips of the shaft seals 949-0836-45 will be coated with lubricating pump oil, being careful not to fill the doweling pin holes. Pay special attention to the position of the lips of the shaft seals as in fig. 06.
- b) After the pump has been re-assembled, it is important to fill up the two holes of the front bearing plate 949-0525-75 with oil.
- c) Use a torque wrench to tighten the three nuts 949-0712-14. Maximum torque: 1 kgf-meter (7.25 foot-pound).
- d) The anti-suckback valve assembly must be re-adjusted only if it has been completely dismantled. Proceed as follows (see fig. 04).

1. Slowly turn the pump shaft counterclockwise until the axes of the impeller (A), clips (B) and the seat (C) are in line (B between A and C).
2. Offset the came while holding the impeller with a finger so as to exert a slight force in (F) direction.
 - With the came offset, the anti-suckback valve should be able to rise to about 1.3 to 1.5 mm (0.050" to 0.060").
 - The surface of the seat (C) and the anti-suckback valve (3) must be parallel. This adjustment is made by loosening the screw (4) and rotating seat (C). After these operations, check that the lever returns properly to its seat (C).
- e) Do not reverse the aluminium plate 949-0526-30 and the gasket 949-0525-55. The gasket must be facing the motor.
- f) Check the fan position (see fig. 05).
 1. 50 Hz (IEC MOTOR)
 - Place the coupling 949-0525-54 against motor shaft shoulder if the latter has been dismantled.
 - Casing/fan clearance: 0.5 to 1 mm (0.020" to 0.040"). This clearance is measured between the inner side of the frame 949-0525-45 and the rear of the fan 949-0525-52.
 2. 60 Hz (U.S. MOTOR)
 - Install adaptor flange 949-0525-89 and then slide in place the coupling 949-0526-84 The distance coupling to adaptor flange: $23 \begin{smallmatrix} -0 \\ -0.5 \end{smallmatrix} \text{ mm (} 0.905 \pm 0.020 \text{)}$
 - Casing/fan clearance: 0.5 to 1 mm (0.020" to 0.040").

3.5 ORDERING SPARE PART

For quick delivery of spare parts always note:

1. The type of pump
2. The serial number
These particulars are given on the specification label attached to bracket 949-0525-45
3. The part number as shown in the accompanying illustrations.

To simplify maintenance, we provide ready-packed kits of most commonly required parts. These kits are always available. The use of these kits is recommended, as you are then certain of having all the parts that you are likely to need. In addition, you will receive faster service without risk of error or confusion.

MINOR MAINTENANCE KIT 949-0526-10 (EUROPE) / 0481-P1875-301 (U.S.)

This kit contains all gaskets included in the pump and all parts which have to be replaced whenever the pump is completely dismantled.

MAJOR MAINTENANCE KIT 949-0526-14 (EUROPE) / 0481-P1922-301 (U.S.)

This kit comprises, in addition to the parts in the minor maintenance kit, a set of parts required for maintenance of the pump over a period of two years, under normal working conditions.

Note: The small anti-suckback valve seat mounted on lever 949-0527-50 (supplied as an assembly) is also available separately under 949-0543-40

3.6 TOOLS

Tools required for dismantling and re-assembling the pumping unit:

- Open wrenches: 13 and 10 mm
- Allen keys: 5 - 6 mm
- Circlips pliers i.d.: 26 mm, e.d. 3 mm

IV. ADDENDA

OIL MIST ELIMINATOR

SPECIFICATIONS	Europe	U.S.
Part Number	949-0683-16	0491-P1700-301
Weight	140 grams	0.31 lbs
Pneurop fitting	NW 25	NW 25
Material	Macrolon body	Macrolon body

Replacement Parts:

Cartridge (1" O.D.)	949-0683-04	0491-P1760-301
O-ring	949-0790-15	

FUNCTION

- a) Fits on outlet port of oil-sealed roughing pump with a maximum displacement of 15 m³/hr.
- Required for installation:
 - One centering ring with NW 25 seal 959-3925 (800-0425)
 - One clamp NW 25 959-2025 (800-0225)
- b) Before installation:
- Remove flap valve (if any) from pump outlet port
 - Find the end through which the white cartridge is visible and mount this end on the pump.

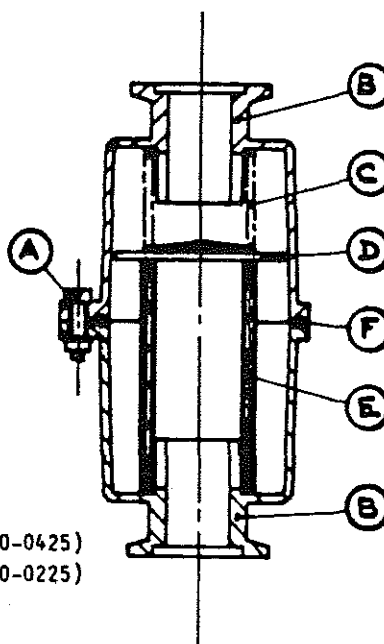

MAINTENANCE

- a) Excessive mist means that the cartridge is saturated and must be replaced.
- b) Disassembly:
- | | |
|------------------------|---|
| Remove assembly screws | A |
| Disassemble - Top | B |
| - Spring | C |
| - Valve | D |
| - Cartridge | E |
| - O-Ring | F |

Clean with a dry cloth (using trichlorethane if necessary)

- c) Reassembly:
- Install new cartridge 949-0683-04 in bottom 8-1, pressing gently to be sure it is firmly seated. Install valve D (Europe) / 0491-PM60-301 (U.S.) with polished side toward cartridge, center spring C on valve D, fit o-ring F in its groove, and cover entire assembly with top B. Assemble B and B-1, using screws A.
- d) After changing the cartridge several times, it may be necessary to replace seal 949-0790-15 as well as centering ring seal 949-0792-38.

4.2 AUTOMATIC GAS BALLAST

SPECIFICATIONS	Europe	U.S.
Part Number	949-0683-95	0491-P1790-301
Weight	250 grams	0.55 lbs
Material	stainless steel	stainless steel
Volts/cycles	220 V 50 Hz	115 V 60 Hz
Replacement Parts:		
Seal	949-0683-99	

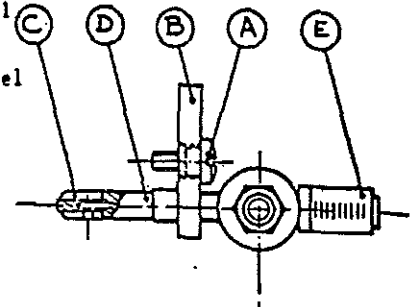

FUNCTION

- a) Remote control of gas ballast
- b) Replace standard manual gas ballast assembly using the same mounting screw A.

INSTALLATION

- a) Remove manual gas ballast assembly by unscrewing screw A (be sure to remove valve from bottom of seat).
- b) Before installation, be sure seal C is properly aligned. The hole in the seal and the hole in tube D must match.
- c) Insert automatic gas ballast assembly in opening and mount using screw A.
- d) Connect solenoid leads.

MAINTENANCE

- a) Periodic cleaning is all that is required to ensure proper functioning of the gas ballast. Disconnect solenoid leads. Unscrew mounting screw A. Remove gas ballast assembly B from pump.
- b) Clean seal C and tube D with alcohol. Degrease Filter E using trichlorethane and dry with compressed air. Reassemble in reverse order. (Install new seal 949-0683-99, if necessary). Be sure seal is properly installed.

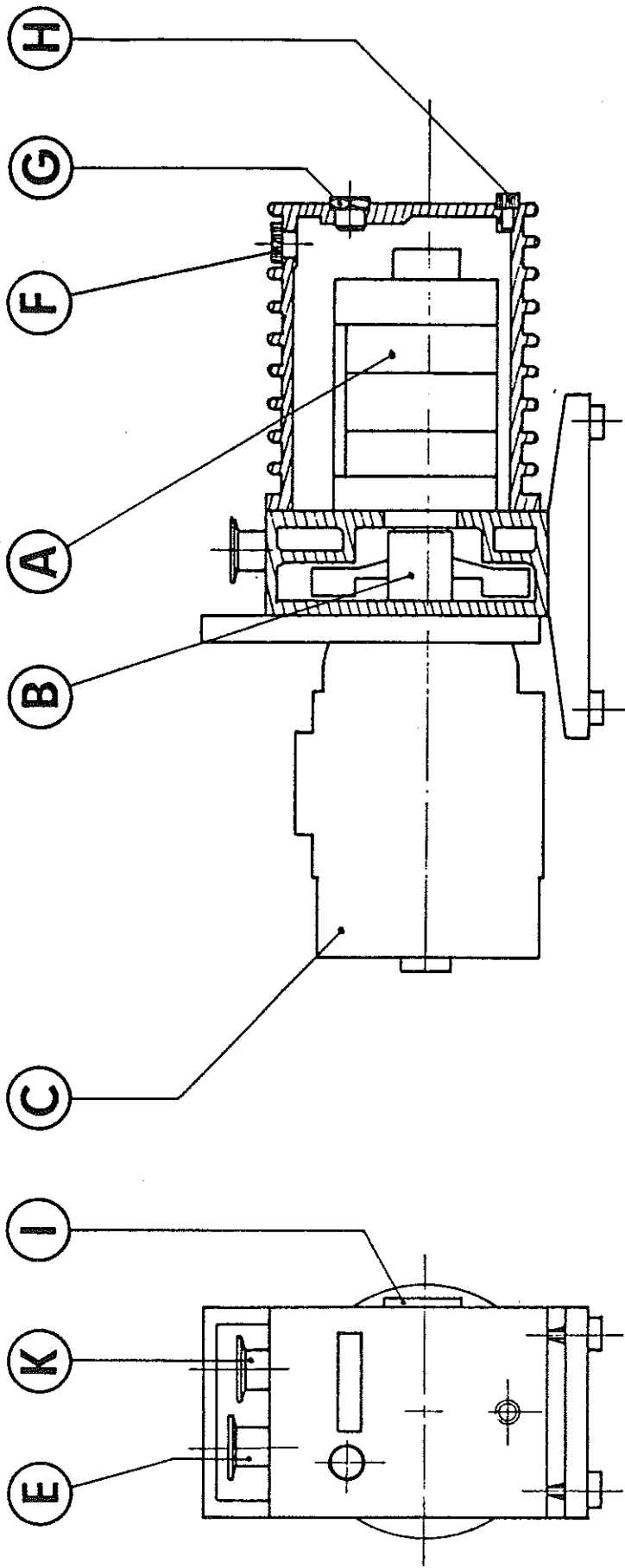
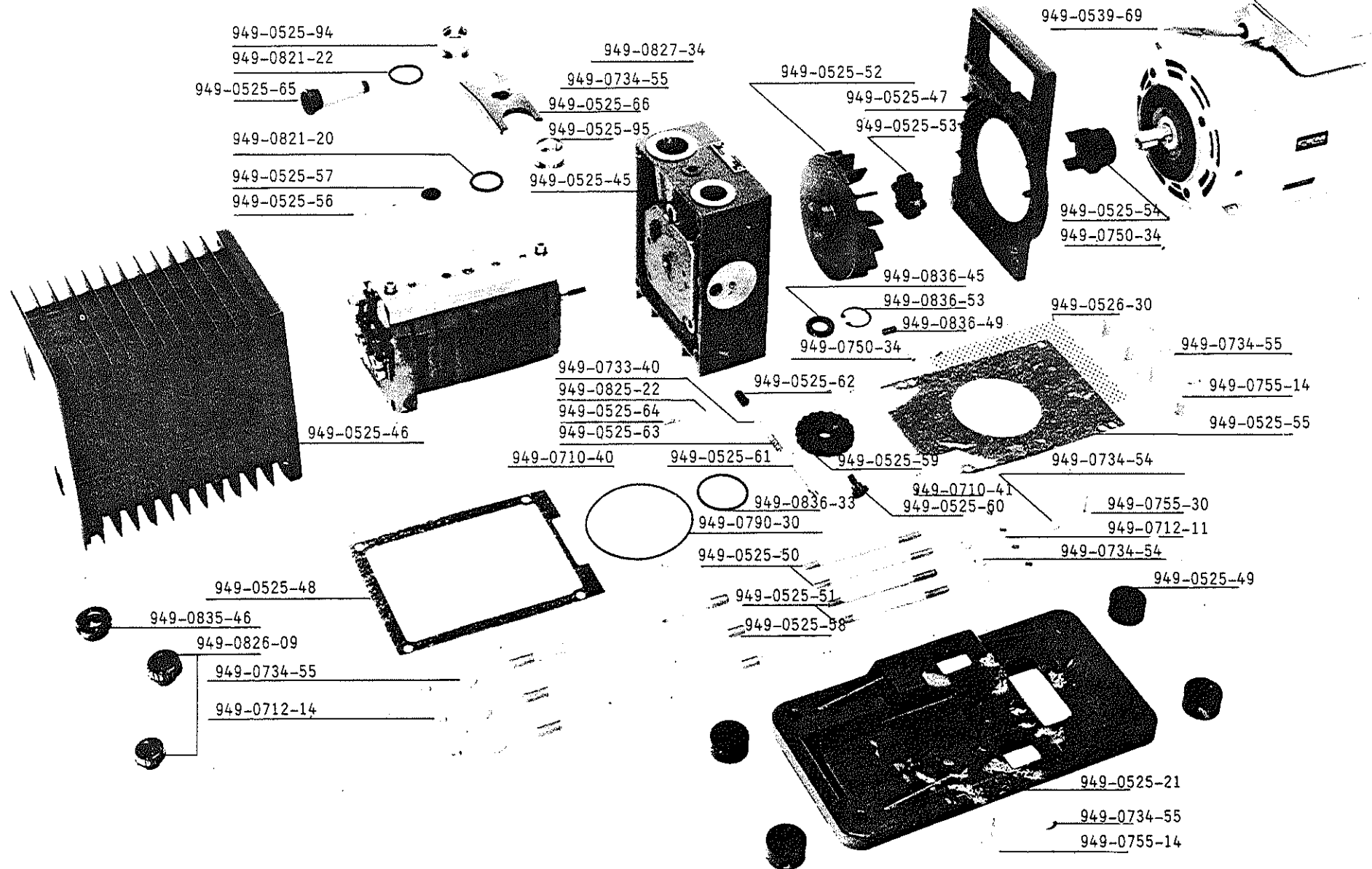
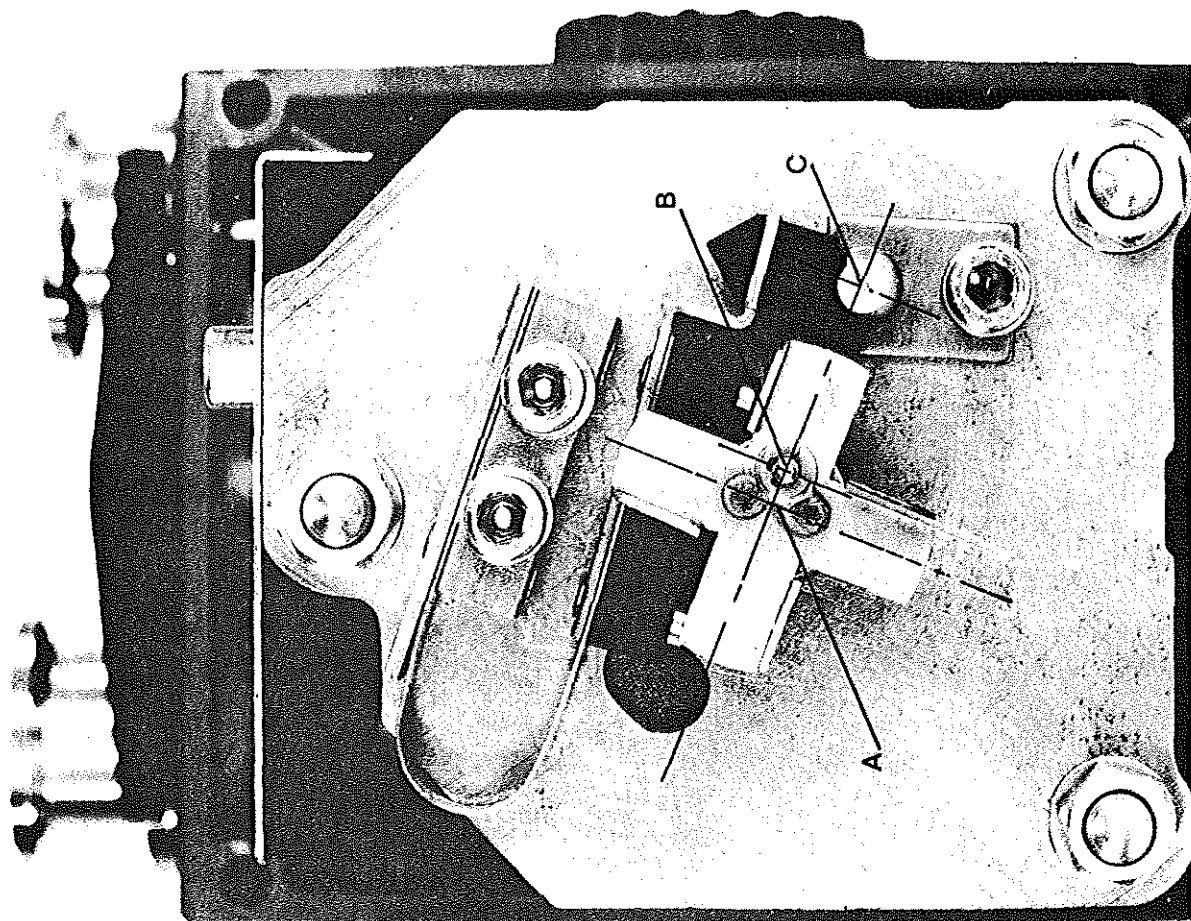

FIGURE 01

Mono.	50 Hz	949-0526-07
	60 Hz	949-0526-06
Tri	50 Hz	949-0526-00
	50 Hz	949-0526-04 AEG
	60 Hz	949-0526-01





A

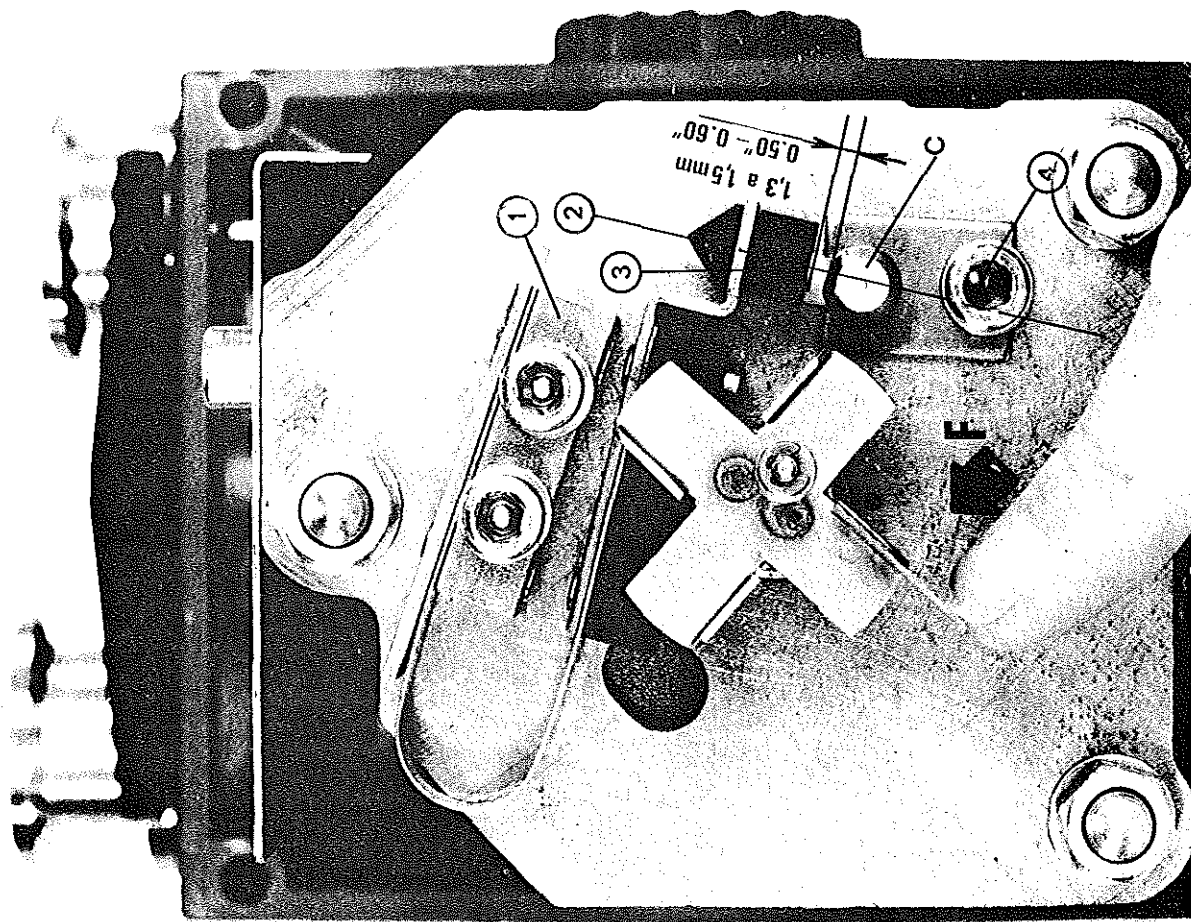

B

FIGURE 04 ADJUSTEMENT OF ANTI-SUCKBACK VALVE ASSY. (see 3.3.4.)

949-0526-30

949-0526-30

motor

U.S. Motor

$\pm 0,5$
 ± 0 mm

$\pm 0,5$
 ± 0 mm

23
 -0
 $-0,5$ mm

1 - 50 Hz (IEC Motor)

2 - 60 Hz (U.S. Motor)

FIGURE 05 — COUPLING / FAN ADJUSTMENT

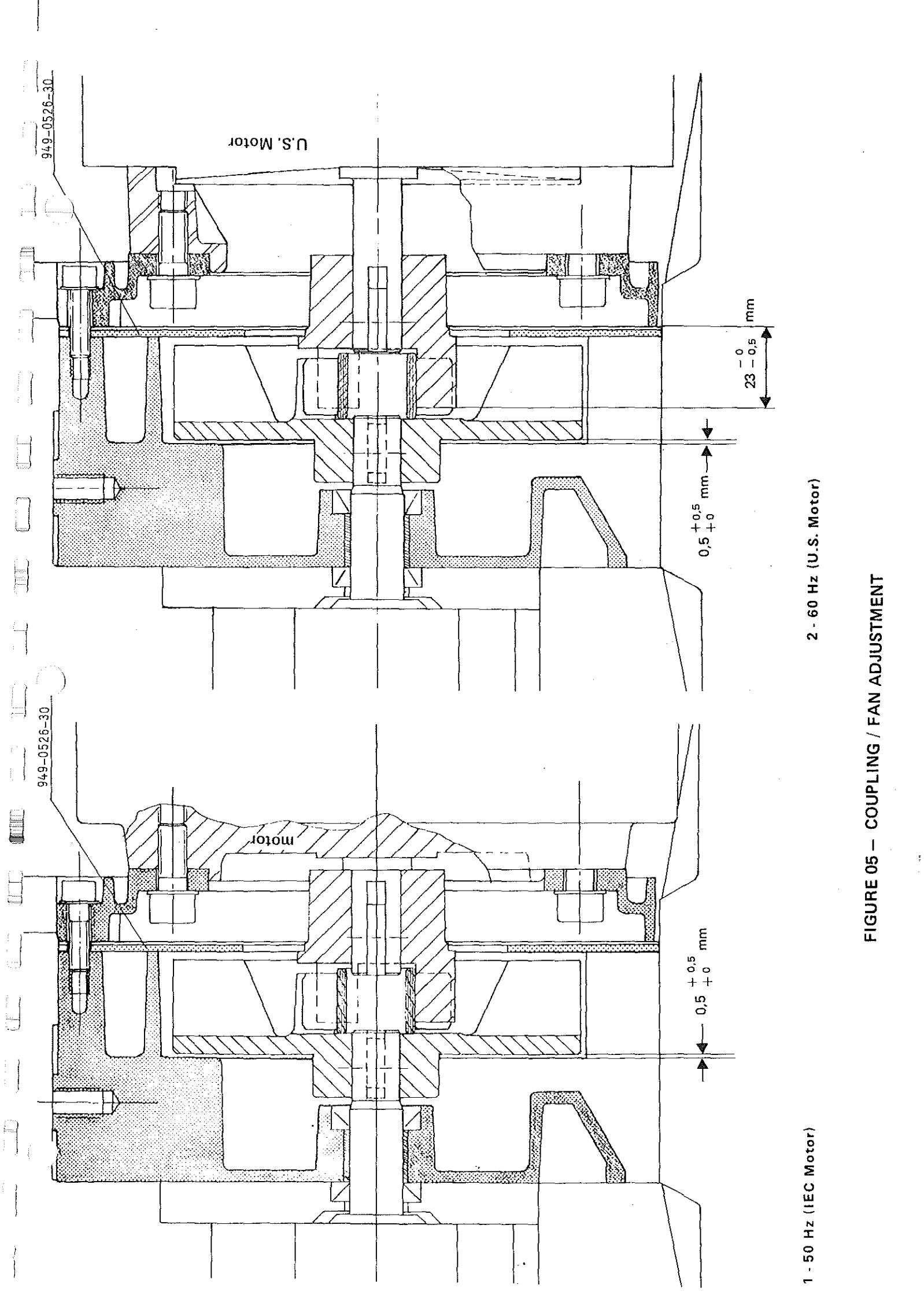

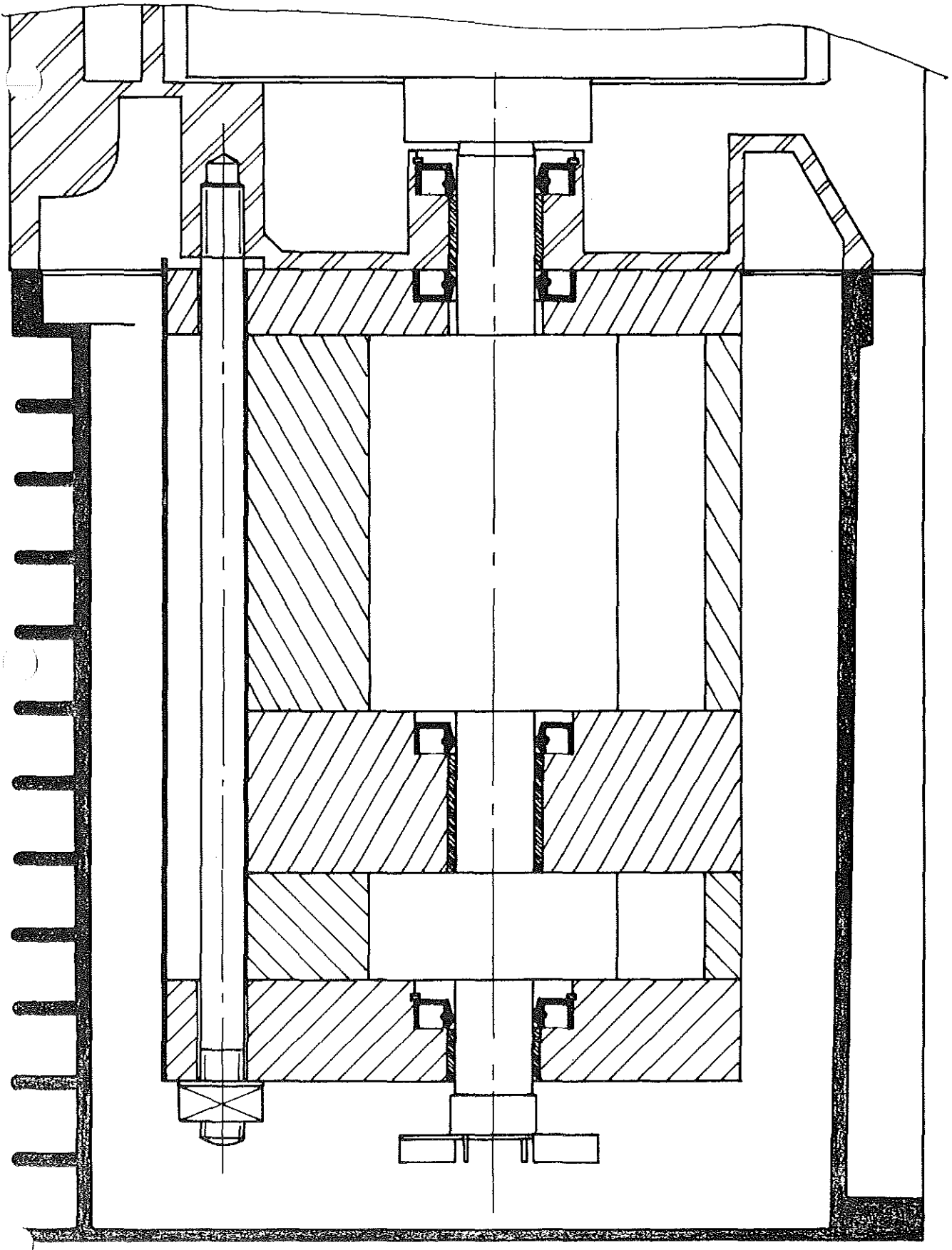

FIGURE 06 ASSEMBLY OF SHAFT SEALS

57

61

60

E J

7

66

H J

I G

17

16

2

55

15

59

5

I

B

30

1

65

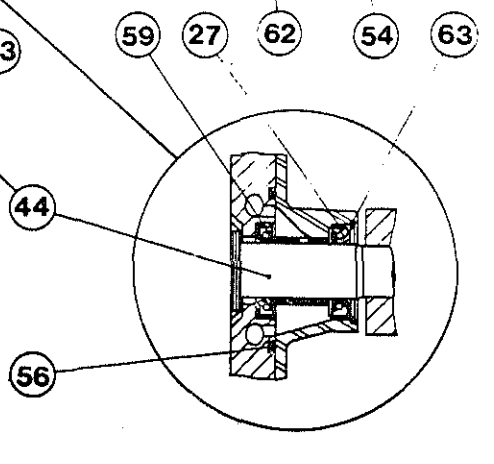
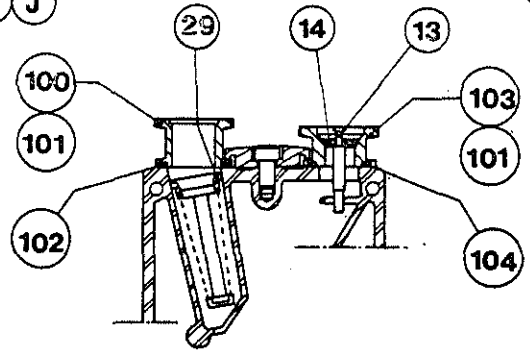
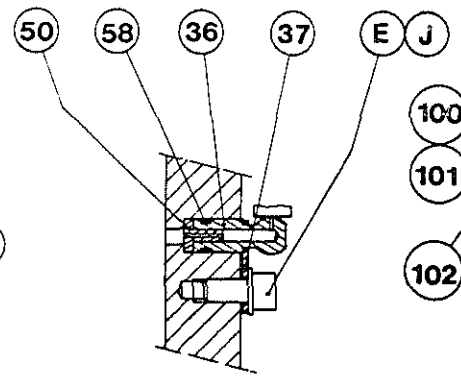
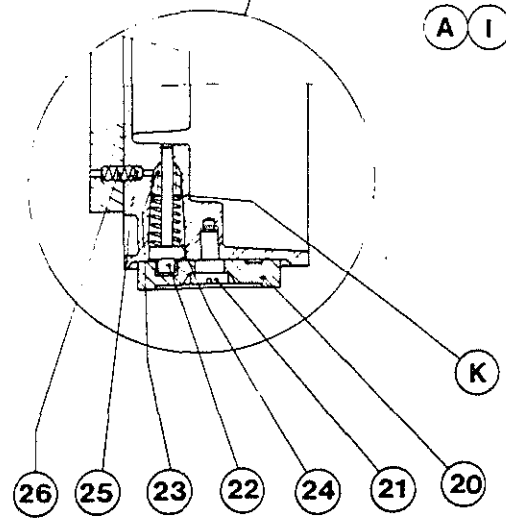
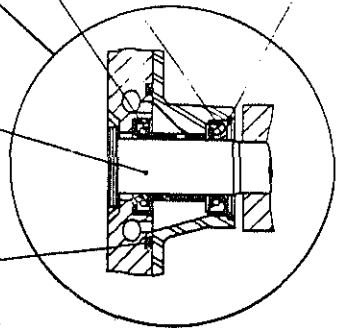
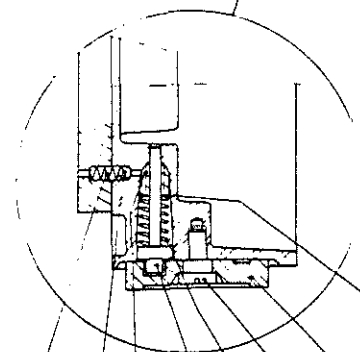
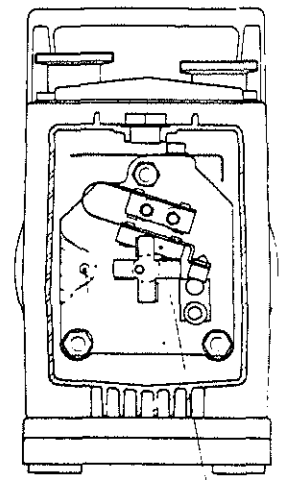
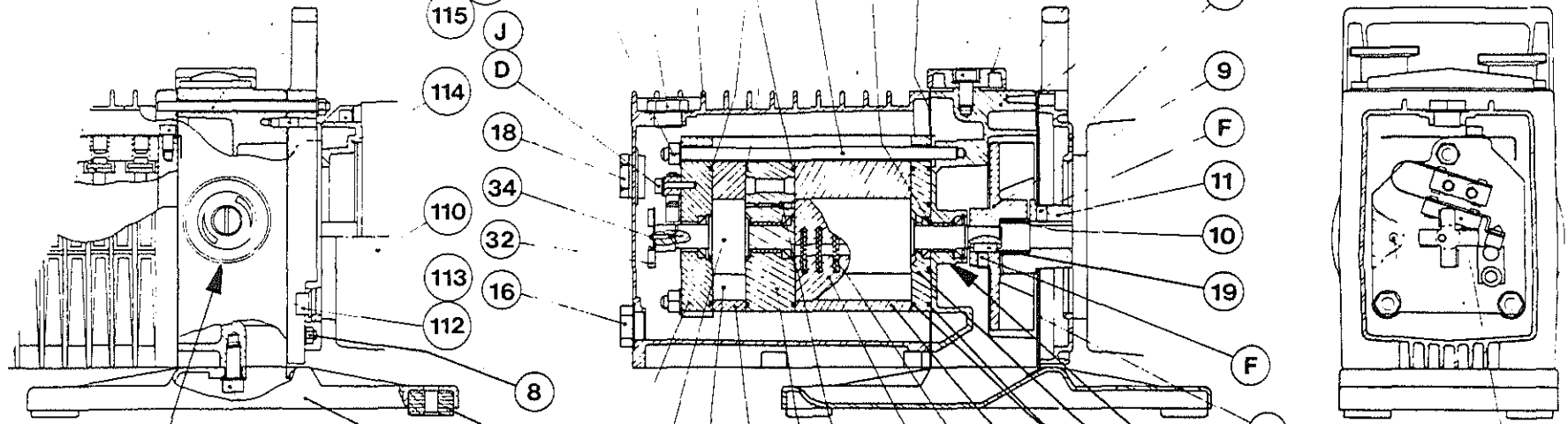
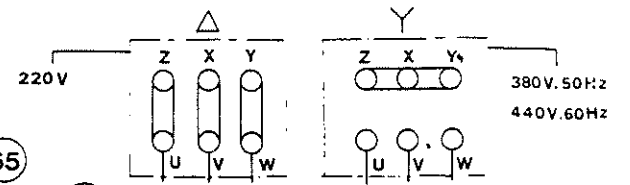

SPARE PARTS LIST FOR SS-90, SD-90
SD-200, SS-300, SD-300

Rép	Désignation	Benennung	Specification	TYPE					Bestell-Nr. Part Number No de Réf. EUROPE	Bestell-Nr. Part Number No de Réf. USA
				SD-300	SS-300	SD-200	SD-90	SS-90		
1	Baît	Pumpenträger	Coupling box	1	1	1	1	1	949-0525-45	
2	Cuve 12 m³	Ölbehälter 12 m³	Oil casing 12 m³	1	1	1			949-0525-46	
2	Cuve 4 m³	Ölbehälter 4 m³	Oil casing 4 m³				1	1	949-0525-44	
3	Socle	Fuss	Base	1	1	1	1	1	949-0525-21	
4	Flasque moteur	Motorflansch	Handle plate	1	1	1	1	1	949-0525-47	
5	Joint cuve	Öldichtung	Oil casing gasket	1	1	1	1	1	949-0527-55	
6	Amortisseur	Schwingmetall	Shock absorber	4	4	4	4	4	949-0525-49	
7	Goujon (long)	Gewindestift (long)	Connection pin (long)	2	2	2	2	2	949-0525-50	
8	Goujon (court)	Gewindestift (kurz)	Connection pin (short)	2	2	2	2	2	949-0525-51	
9	1/2 Manchon	Kupplungshälfte	Fan coupling	1	1	1	1	1	949-0525-52	
10	Intercalaire	Kupplungstern	Plastic coupling	1	1	1	1	1	949-0525-53	
11										
12	Défecteur	Umlenkblech	Fan plate	1	1	1	1	1	949-0525-55	
13	Axe de soupape	Ventilstift	Valve pin	1	1	1	1	1	949-0525-56	
14	Soupape (refoulement)	Auspuffventil	Exhaust valve	1	1	1	1	1	949-0525-57	
15	Goujon	Stift	Pin	3					949-0525-58	
15	Goujon	Stift	Pin		3		3		949-0525-84	
15	Goujon	Stift	Pin			3			949-0525-83	
15	Goujon	Stift	Pin					3	949-0525-85	
16	Bouchon (mâle G 3/8)	Blindstopfen 3/8"	Plug G 3/8"	2	2	2	2	2	949-0826-04	
17	Joint c 2,7 d 15.10	Dichtung c 2,7 d 15.10	O ring c 2,7 d 15.10	2	2	2	2	2	949-0821-12	
18	Indicateur (huile)	Ölschauglas	Oil level sight glass	*1	*1	*1	*1	*1	949-0835-46	
19	Clavette	Nutenstein	Shall key	*1	*1	*1	*1	*1	949-0836-49	
20	Boulon de manoeuvre	Gasballast knopf	Gas ballast knob	*1	*1	*1	*1	*1	949-0525-59	
21	Vis épaulée	Schraube	Screw	*1	*1	*1	*1	*1	949-0525-60	
22	Piston lest d'air	Ventilkolben G.B. Ventil	Gas ballast piston	*1	*1	*1	*1	*1	949-0525-61	
23	Clapet lest d'air	Gasballast Ventil	Gas ballast valve	*1	*1	*1	*1	*1	949-0525-62	
24	Ressort du piston	Feder	Piston spring	*1	*1	*1	*1	*1	949-0525-63	
25	Bille 11/64" ø4,366 DIN 5401	Kugel 11/64" ø4,366 DIN 5401	Bearing 11/64" ø4,366 DIN 5401	*1	*1	*1	*1	*1	949-0825-22	
26	Ressort bille	Feder	Spring bearing	*1	*1	*1	*1	*1	949-0525-64	
27	Joint à lèvres (viton)	Lippendichtung (viton)	Shaft seal (viton)	*1	*1	*1	*1	*1	949-0820-63	
28										
29	Filtre d'aspiration	Ansaugfilter	Inlet Filter	*1	*1	*1	*1	*1	949-0525-65	
30	Bride étrier	Spannstück	Clamping strap	*1	*1	*1	*1	*1	949-0528-28	
31										
32	Moulinet	Flügelnocke	Impeller	*1		*1			949-0527-21	
32	Moulinet	Flügelnocke	Impeller		*1			*1	949-0527-06	
33										
34	Bague d'arrêt	Sprengring	Stop nut	*1	*1	*1	*1	*1	949-0711-61	
35	Rotor équipé H.P.	Hochdruck rotor	High pressure rotor	*1		*1			949-0527-12	
36	Siège de clapet	Ventilsitz	Pin supporting jet	*1	*1	*1	*1	*1	949-0527-18	
37	Bride	Lasche für Ventilsitz	Jet support flange	*1	*1	*1	*1	*1	949-0525-69	
38										
39	Flasque arrière	Hinterer Flansche	Rear plate	*1	*1	*1	*1	*1	949-0526-86	
40	Stator H.P.	Hochdruck Stator	High pressure stator	*1		*1			949-0527-11	
41	Flasque médian	Zwischenflansch	Central plate	*1		*1			949-0525-73	
42	Stator B.P.	Niederdruck Stator	Low pressure stator	*1					949-0525-74	
42	Stator B.P.	—	Low pressure stator			*1			949-0525-82	
42	Stator B.P.	—	Low pressure stator				*1		949-0525-72	
43	Flasque avant	Vorderer Flansche	Front plate	*1	*1	*1	*1	*1	949-0525-75	
44	Rotor B.P.	Niederdruck Rotor	Low pressure rotor	*1					949-0525-09	
44	Rotor B.P.	—	Low pressure rotor			*1			949-0525-12	
44	Rotor B.P.	—	Low pressure rotor				*1		949-0525-13	
45										
46	Ressort (palette)	Schleberfeder	Vane spring	*9	*7	*6	*4	*2	949-0530-40	
47	Palette H.P.	Hochdruck Schleber	High pressure vane	*2		*2	*4	*2	949-0839-46	
48	Palette B.P.	Niederdruck Schleber	Low pressure vane	*2	*2				949-0839-45	

JIM BROWN

X54774

Rép	Désignation	Benennung	Specification	TYPE					Bestell-Nr Part Number No de Réf. EUROPE	Bestell-Nr Part Number No de Réf. USA
				SD-100	SS-300	SD-200	SD-90	SS-90		
48	Palette B.P.	Hochdruck Schieber	Low pressure vane				*2		949-0531-06	
49	Gicleur (médián)	Zentral Düse	Central jet	*1		*1	*1		949-0534-74	
50	Gicleur	Düse	Oil jet	*1		*1	*1		949-0527-17	
50	Gicleur	Düse	Oil jet		*1				949-0527-28	
50	Gicleur	Düse	Oil jet					*1	949-0527-22	
51										
52	Rotor/stator	Rotor/Stator	Rotor/stator		*1				949-0526-71	
52	Rotor/stator	Rotor/Stator	Rotor/stator					*1	949-0526-70	
53										
54	Levier	Hebel	Lever	*1	*1	*1	*1	*1	949-0527-50	
55	Joint c 2 d 82	Dichtung c 2 d 82	O-Ring c 2 d 82	*5	*3	*5	*5	*3	949-0790-30	
56	Joint c 2,5 d 38	Dichtung c 2,5 d 38	O-Ring c 2,5 d 38	*1	*1	*1	*1	*1	949-0836-33	
57	Soupape	Auslassventil	Valve	*4	*3	*3	*2	*1	949-0526-55	
58	Joint c 1,9 d 5,70	Dichtung c 1,9 d 5,70	O-Ring c 1,9 d 5,7	*1	*1	*1	*1	*1	949-0821-05	
59	Joint à lèvres	Lippendichtung	Shaft seal	*3	*2	*3	*3	*2	949-0836-45	
60	Capot de soupape	Ventilgehäusedeckel	Valves cover	*1	*1				949-0525-80	
60	Capot de soupape	Ventilgehäusedekd	Valves cover			*1			949-0525-38	
60	Capot de soupape	Ventilgehäusedekd	Valves cover				*1	*1	949-0525-39	
61	Ressort de soupape	Ventilfeder	Valve spring	*4	*3	*3	*2	*1	949-0525-41	
62	Rouleau ø6	Zentrierstift ø6	Centering pin ø6	*10	*6	*10	*10	*6	949-0710-40	
63	Frein d'axe	Sprengring	Circip	*2	*2	*2	*2	*2	949-0836-53	
65	Cloison	Zwischenwand	Fan plate	*1	*1	*1	*1	*1	949-0526-30	
66	Rouleau ø6	Zentrierstift ø6	Centering pin ø6	*2	*2	*2	*2	*2	949-0710-41	
100	Embout d'aspiration NW 25 A	Ansaugstutzen NW 25 A	Inlet port NW 25 A	*1	*1	*1	*1	*1	949-0525-94	
101	Protecteur	Schutzkappe	Plastic cover	*2	*2	*2	*2	*2	949-0680-11	
102	Joint c 3,6 d 29,3	Dichtung c 3,6 d 29,3	O-Ring c 3,6 d 29,3	*1	*1	*1	*1	*1	949-0821-22	
103	Embout de refoulement	Druckstutzen	Exhaust	*1	*1	*1	*1	*1	949-0527-54	
104	Joint c 3,6 d 26,2	O-Ring c 3,6 d 26,2	O-Ring c 3,6 d 26,2	*1	*1	*1	*1	*1	949-0821-20	
A	Vis M 8 x 20	Schraube M 8 x 20	Screw M 8 x 20	*2	*2	*2	*2	*2	949-0755-14	
B	Vis M 8 x 16	Schraube M 8 x 16	Screw M 8 x 16	*1	*1	*1	*1	*1	949-0827-36	
C										
D	Vis M 6 x 16	Schraube M 6 x 16	Screw M 6 x 16	*2	*2	*2	*2	*2	949-0755-09	
E	Vis M 6 x 10	Schraube M 6 x 10	Screw M 6 x 10	*3	*3	*3	*3	*3	949-0755-08	
F	Vis M 6 x 10 bout plat	Schraube M 6 x 10 Fladkopf	Screw M 6 x 10 (flat end)	*2	*2	*2	*2	*2	949-0750-34	
G	Ecrou HM 8	Mutter HM 8	Screw nut HM 8	*3	*3	*3	*3	*3	949-0712-14	
H	Ecrou HM 6	Mutter HM 6	Screw nut HM 6	*4	*4	*4	*4	*4	949-0712-11	
I	Rondelle ø8	Unterlagescheibe ø 8	Washer ø8	*6	*6	*6	*6	*6	949-0734-55	
J	Rondelle ø6	Unterlagescheibe ø 6	Washer ø6	*9	*9	*9	*9	*9	949-0734-54	
K	Rondelle ZU 4	Unterlagescheibe ZU 4	Washer ZU 4	*3	*3	*3	*3	*3	949-0733-40	
MOTEUR 50 HZ										
110	Moteur mono 220 V 375 W 1 500 tr/mn	Einphasen WS Motor 220 V 375 W 1500 tr/mn	Single phase electric motor 220 V 375 W 1500 tr/mn	*1	*1	*1	*1	*1	949-0526-07	
110	Moteur triph. 220 V/380 V 375 W 1 500 tr/mn	Drehstrommotor 3x220/380 V 375 W 1500 tr/mn	Three phase electric motor 220/380 V 375 W 1500 tr/mn	*1	*1	*1	*1	*1	949-0526-02	
111										
112	Vis M 8 x 16	Schraube M 8 x 16	Screw M 8 x 16	*4	*4	*4	*4	*4	949-0827-34	
113	Rondelle ø8	Unterlagescheibe ø 8	Washer ø8	*4	*4	*4	*4	*4	949-0734-55	
MOTEUR 60 HZ										
110	Moteur mono 115 V/230 V 375 W 1 800 tr/mn	Einphase US Motor 115/230 V 375 W 1800 tr/mn	Single phase electric motor 115/230 V 375 W 1800 tr/mn	*1	*1	*1	*1	*1	949-0526-06	
111										
112	Vis 5/16" 3/4"	Schraube 5/16" 3/4"	Screw 5/16" 3/4"	*4	*4	*4	*4	*4	949-0750-37	
113	Rondelle ø8	Unterlagescheibe ø 8	Washer ø8	*4	*4	*4	*4	*4	949-0754-55	
114	Flasque	Flansch	Plate	*1	*1	*1	*1	*1	949-0525-89	
115	Vis 3/8" 1"	Schraube 3/8" 1"	Screw 3/8" 1"	*4	*4	*4	*4	*4	949-0750-38	
116	Rondelle ø10	Unterlagescheibe ø 10	Washer ø10	*4	*4	*4	*4	*4	949-0734-56	