

OME 40 S

Séparateur de brouillard standard
Standard oil mist eliminator
Standard Ölnebelabscheider

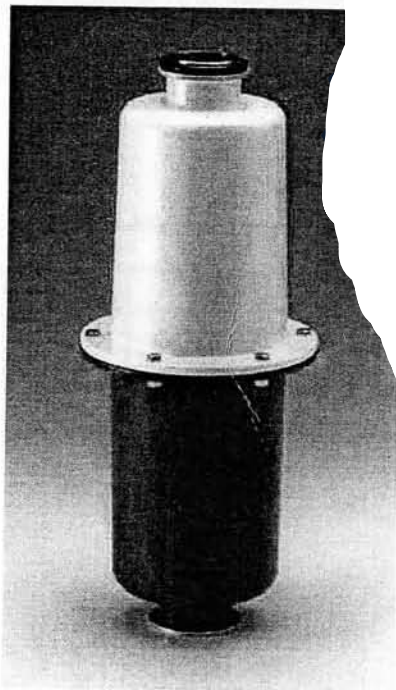

Manuel de l'utilisateur
User's manual
Technische Beschreibung

Chemtech Scientific provides access to this content as a courtesy.
We do not own the content contained in this document.
All rights and credit go directly to its rightful owners.
www.chemtechsci.com
Call us at: 484-424-9415



II. STANDARD OIL MIST ELIMINATOR

II.1. DESCRIPTION

The oil mist eliminator is mounted at the exhaust of the 1033/1063/2033/2063 standard rotary vane pumps and separates oil droplets and vapours gases emitted at the exhaust of the oil-sealed vacuum pumps.

When the eliminator is mounted vertically, the condensed oil is recovered by flowing back through the cartridge into the oil case, if the inlet pressure is less than 0.75 Torr for a sufficiently long time.

The eliminator has a safety valve set to 375 Torr relative pressure which prevents overpressure in the pump oil case when the cartridge is saturated. Do not allow solid or pasty deposits issuing of pumped vapours to stick the valve to the filter cartridge.

II.2. CHARACTERISTICS

Part number	104887 (Model OME 40S)
Weight	4.408 lbs
Connection	DN40 ISO-KF
Material	body : aluminium cartridge : glass microfiber and epoxy resin
Tightness:	1×10^{-7} Pa.m ³ .s ⁻¹ (1×10^{-6} atm.cm ³ .s ⁻¹)
Mounting on pump	body marked with " Pump ↓ " label
Dimensions	see Figure a) .

EQUIPPED WITH	REPERE	REFERENCE
1 centering ring DN40 ISO-KF	<u>13</u>	068194
1 quick connect clamp DN40 ISO-KF	<u>15</u>	083267

II.3. ASSEMBLY (Figure b)).

The separator is installed on the rotary vane pump exhaust flange with the side included "**Pump ↓**" label. The other side can be connected to a gas exhaust line.

- On the pump, **remove protective and elastomer valve from the exhaust port of the vane pump.**
- On the oil mist eliminator, remove protectives **12** and **14**.
- Connect oil mist eliminator to pump with connecting accessories supplied (here above) or ordered separately (**see diagram 1**).
- Start the pump.

In operation, oil and vapours are collected by the filter until it clogs, in which case, valve **5** bypasses the filter if the internal pressure is higher than 375 Torr relative pressure.

In all cases :

- The oil mist eliminator can be located far from the pump.
- Use a suitable diameter of pipe between pump and oil mist eliminator.
- **Connect the nipple marked with the "**Pump ↓**" label on the exhaust side of the pump.**

If the oil mist eliminator is connected to a ventilating duct, **check to be sure the pressure loss in this equipment does not exceed 375 torr relative.**

II.4. MAINTENANCE

IMPORTANT : Each time the system is dismantled, take all necessary precautions to ensure safety and protection of personnel against toxicity, corrosion, and radioactivity of residues. Depending on the nature of the residue, we recommend :



- 1. Purging the system with dry nitrogen before working on it.
- 2. Wearing gloves, goggles and, if necessary, an oxygen mask.
- 3. Thorough ventilation of the room and disassembly under a fume hood.
- 4. Recovery of residue in appropriate containers. If necessary, have them destroyed by a competent organization.

a) Cartridge saturation :

If excessive fumes or droplets, or bursts of vapour appear at eliminator outlet, the cartridge is saturated.

The time taken to reach saturation point depends on the number of pumping operations, their frequency, the volume of pumped gas, and the kind of the oil used. When the cartridge is saturated, replace as follows :

b) Disassembly (Figure c) :

- Detach the eliminator from the pump and disassemble on a workbench.
- Unscrew the 6 nuts **8**, **9** and **10** while at the same time manually pressing each end of the eliminator (**to avoid sudden release of the spring 6**).
- Remove successively and in the following order, the upper body **16**, O-ring **7**, the spring **6**, the valve **5** equipped with its ring **4**, the cartridge **2** and the flat ring **3**, in the base of the body **1**.

c) Cleaning :



Never clean the filter cartridge: always install a new one.

After use in mineral oil, clean the components with a mineral products based solvent such as **AXAREL** ⁽¹⁾, **CARECLEAN** ⁽²⁾, **PREMACLEAN** ⁽³⁾, **NAPHTEOL** ⁽⁴⁾.

Proceed as follows :

- Clean when cold or hot (max. 45°C) by dipping or using a cloth,
- Vacuum dry in a ventilated oven,
- Elastomer seals **3**, **4** and **7** must always be replaced by new seals.

- (1) DUPONT DE NEMOURS registered trademark
- (2) CASTROL registered trademark
- (3) DOW registered trademark
- (4) NIPPON CHEMICAL registered trademark

d) Reassembly :

- Insert the flat ring **3** in the base of the body **1**.
- Install the cartridge **2** so that it rests on the flat ring **3** in the body **1**.
- Assemble O-ring **4** on safety valve **5** and install the unit on the cartridge, with the seal resting on the cartridge.
- Position the spring **6** on the valve **5** and O-ring **7**.
- Position the upper body **16** on lower body **1** using the mounting screws **8**, **9**, and **10**.
- Connect the eliminator to the pump exhaust port (see **paragraph II.3.**).

II.5. APPLICATIONS NOT RECOMMENDED

Use of an oil mist eliminator is not recommended in the following cases : drying, freedrying, pumping condensable gases, impregnation with polymerizable resins, and debubbling monomers.



Filter cartridges are flammable : do not use eliminators when pumping flammable products such as oxygen or silane.

The standard oil mist eliminator must also not be used for pumping corrosive products or for microelectronic and chemical applications.

II.6. SPARE PARTS

Parts which must be replaced each time the cartridge is changed :

REPERE	NOMBRE	PART NAME	REFERENCE
2	1	Filter cartridge	068443
3	1	Flat ring	068446
4	1	O-ring	082131
7	1	O-ring	079248

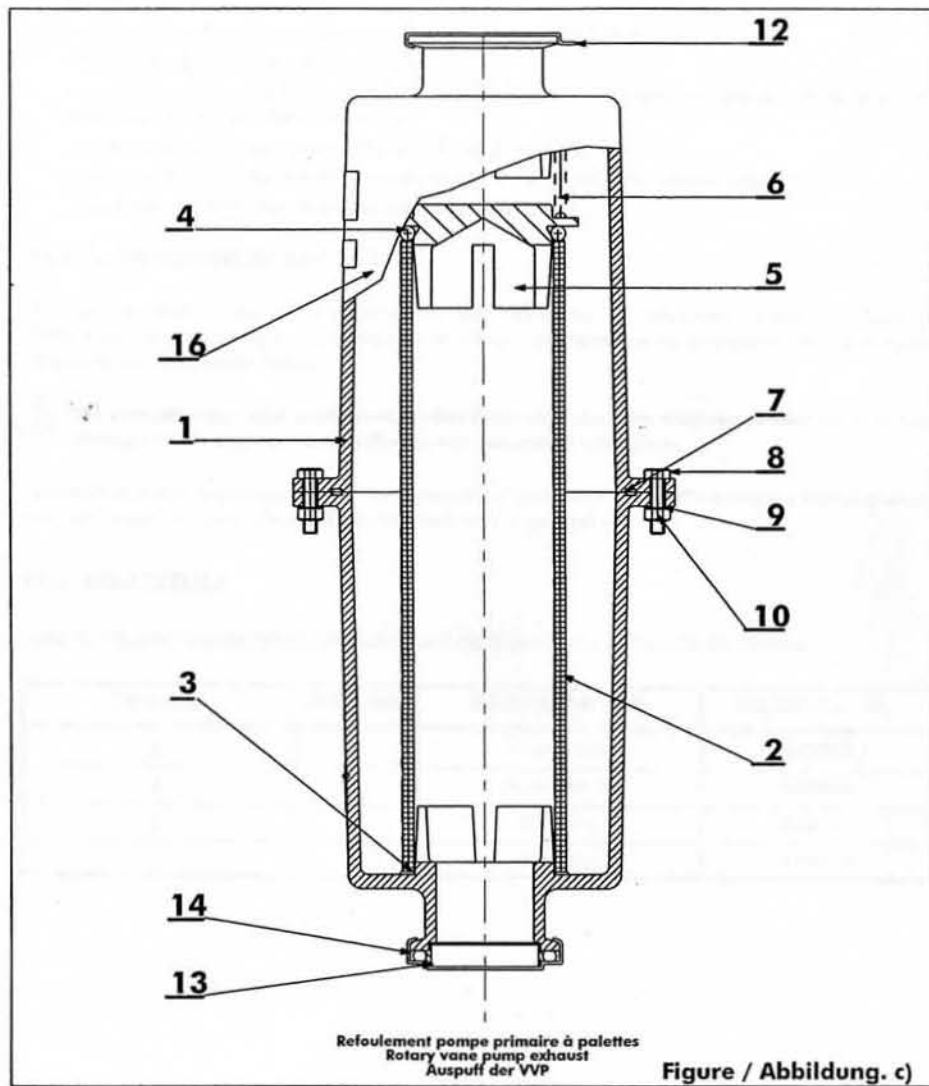

FIGURES / ABBILDUNGEN



PLANCHE 1 / / DIAGRAM 1 / / ABILDUNG 1

RACCORDEMENT ET ELEMENTS DE CANALISATION	ACCESSOIRES DE	CONNECTING ACCESSORIES AND VACUUM FITTINGS	ANSCHLUSSFLANSCHS UND VERBINDUNGSELEMENTS	RACCORDEMENT DN40 ISO-KF RÉF. DN40 ISO-KF CONNECTION P/N DN40 ISO-KF FLANSCH Best.Nr.	
				Pompe standards Standard pumps Standard-Pumpen	Pompes chimiques Chemical pumps Chemie-Pumpen
Anneaux de centrage - inox/Perbunan - inox/Viton - macrovac/Perbunan	ununan	Centering rings - stainless steel/Buna - stainless steel/Viton - macrovac/Buna	Zentrieringe - Edelstahl/Perbunan - Edelstahl/Viton - PVC / Perbunan 068194 109860 083267 068230 083267
Collier de serrage		Quick connect clamp	Spannringe 068194 109860 083267 068230 083267
Tuyau plastique armé - longueur	m 1 longueur	Reinforced plastic hoses - 1 m length	Plastikschläuche - Länge 1 m 303390 068217
Tuyaux flexibles inox - longueur 0,5 m - longueur	m 1 longueur	Flexible stainless steel hoses - 0.5 m length - 1 m length	Edelstahl-Weilschläuche - Länge 0,5 m - Länge 1 m 068374 068375 068374 068375
Embouts lisse - Macrovac - inox	Macrovac - inox	Long nipples - Macrovac - stainless steel	Anschweisflanche - PVC - Edelstahl 068592 068217
Coudes égaux - Macrovac - inox	Macrovac - inox	Symmetrical elbows - Macrovac - stainless steel	Winkelstücke 90° - PVC - Edelstahl 068587 303028
Tés égaux - Macrovac - inox	Macrovac - inox	Symmetrical tees - Macrovac - stainless steel	T-stücke - PVC - Edelstahl 068588 068566
Obtrateurs - Macrovac - inox	Macrovac - inox	Blank-off flange - Macrovac - stainless steel	Blindflansche - PVC - Edelstahl 068595 068197

NOMENCLATURE OME 40S / OME 40S NOMENCLATURE / NOMENKLATUR OME 40S

REPÈRE REF. Item	DESIGNATION MATERIEL	DESCRIPTION MATERIAL	BENENNUNG WERKSTOFF	REFERENCE P/N Bestell Nr.	Quantité Number Quantität
1	Corps gris Aluminium	Grey Body Aluminium	Gehäuse grau Aluminium	068443	1
2	Cartouche époxy + fibre de verre	Cartridge epoxy binder+glass microfibers	Filtereinsatz Epoxydharz + Mikroglastaser	068443	1
3	Joint Plat élastomère FPMx	Flat-ring elastomer FPMx	Flachdichtung elastomer FPMx	068446	1
4	Joint torique élastomère NBRx	O-ring elastomer NBRx	Dichtung elastomer NBRx	082131	1
5	Clapet polyamide	Valve polyamid	Klappe polyamid		1
6	Ressort acier	Spring steel	Feder Stahl		1
7	Joint torique élastomère NBRx	O-ring elastomer NBRx	Dichtung elastomer NBRx	079248	1
8	Vis acier	Screw steel	Schraube Stahl		6
9	Rondelle acier	Washer steel	Unterlegscheibe Stahl		6
10	Erou acier	Nut steel	Mutter Stahl		6
12 / 14	Protecteurs plastique	Protectives plastic	Schutzkappen Kunststoff		2
16	Corps blanc Aluminium	White Body Aluminium	Gehäuse weiß Aluminium		1

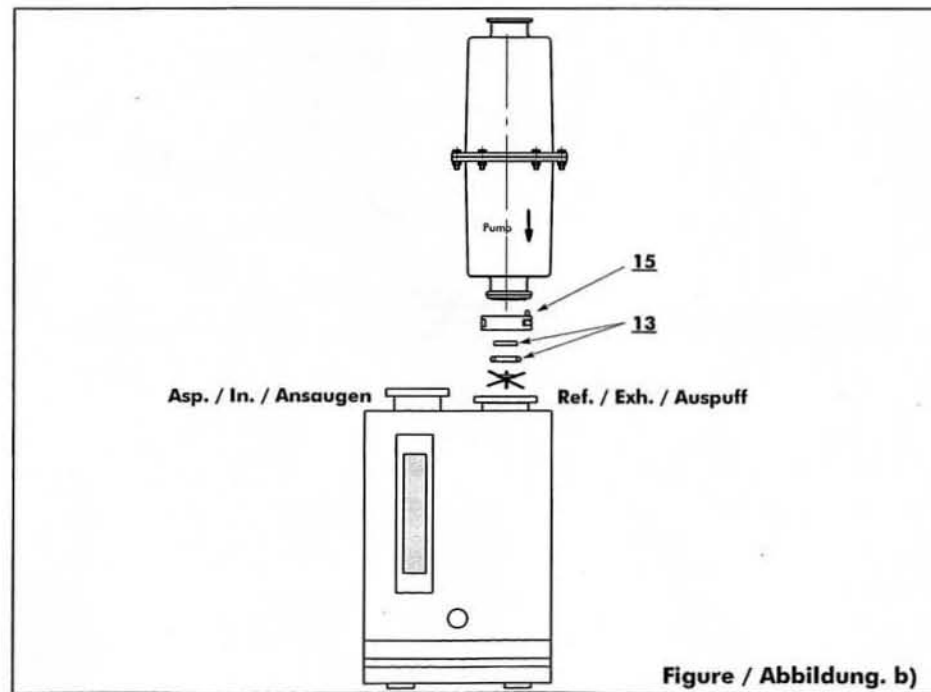
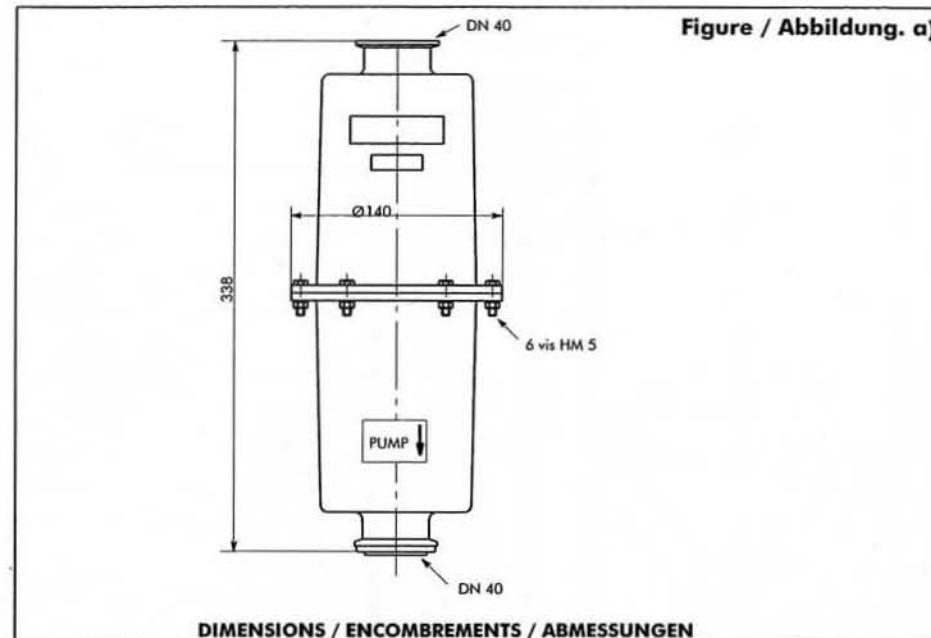
* suivant norme / Following norme / entsprechen der Norm NFT 40-002

PLANCHE 2 / DIAGRAM 2 / ABILDUNG 2