

II. OME 25 HP/HP+ OIL MIST ELIMINATOR

II.1. THE MODELS

The OME 25 HP model and the OME 25 HP+ model are same design but have a different filter capacity.

The OME 25 HP is designed for applications involving frequent cycling or high pressure operation. Incorporating a cartridge of bigger capacity, the OME 25 HP+ is the next step toward completely oil free exhausted gases.

II.2. OPERATING PRINCIPLE OF THE ELIMINATOR

The oil mist eliminator is mounted at the exhaust of a rotary vane pump and separates oil droplets and vapours gases emitted at the exhaust of the oil-sealed vacuum pumps. The contaminated oil is filtered.

The eliminator has a safety valve set to 375 Torr relative pressure which prevents overpressure in the pump oil case when the cartridge is saturated. Do not allow solid or pasty deposits issuing of pumped vapours to stick the valve to the filter cartridge.

II.3. OPERATING PRINCIPLE OF THE OIL DRAIN KITS

a) Oil drain kit ODK1

Used with the OME 25 HP/HP+ oil mist eliminator, it allows to re-inject the filtered oil, accumulated in the oil mist eliminator through the gas ballast.

It consists of a drain pipe which is connected on one end to the bottom of the OME 25 HP, and on the other end to the inlet of the gas ballast.

CAUTION

With an ODK1 kit the pump is not sealed when switched off.

b) Oil drain kit ODK2

Used with the OME 25 HP/HP+ oil mist eliminator, it is similar to the ODK1 with a NC solenoid valve located at the inlet of the gas ballast. The valve must be energized.

CAUTION

In case of power failure, the valve will close and the pump will stay tight when stopped.

Chemtech Scientific provides access to this content as a courtesy.
We do not own the content contained in this document.
All rights and credit go directly to its rightful owners.
www.chemtechsci.com
Call us at: 484-424-9415



II.4. CHARACTERISTICS

- Part number: 104199 (OME 25 HP) 108341 (OME 25 HP+)
- Weight: 2.644 lbs
- Connection: DN25 ISO-KF
- Material: body : aluminium
OME 25 HP cartridge: glass microfibers and epoxy resin.
OME 25 HP+ cartridge: borosilicate glass fiber PF impregnated and 100 % polyester fiber /NBR binder.
- Tightness: 1.10^{-6} atm.cm³.s⁻¹
- Mounting on pump: nipple marked with «Pump 1» label
- Dimensions: see Figure e)

EQUIPPED WITH	REFERENCE	PART NUMBER
1 centering ring DN25 ISO-KF	B	068224
1 O-ring DN25 ISO-KF	C	076238
1 quick connect clamp DN25 ISO-KF	D	083264

Available accessories

PART NAME	PART NUMBER
Oil drain kit ODK1	104360
Oil drain kit ODK2 - 230 V 50/60 Hz	104361
Oil drain kit ODK2 - 115 V 60 Hz	104362
Oil drain kit ODK2 - 100 V 50/60 Hz	104363
Oil drain kit ODK2 - 200 V 50/60 Hz	104364
Oil drain kit ODK2 - 24 V DC	104365

II.5. ASSEMBLY

Case 1: The oil mist eliminator is mounted on the exhaust port located vertically on the pump. Proceed as follows:

- Remove the vent valve 150 mounted in the exhaust port 120.
- Assemble as shown in Figure a) using the connection accessories provided with the eliminator.

Case 2: The oil mist eliminator is mounted on the exhaust port located horizontally on the pump.

- Assemble as shown in Figure b) using the connection accessories provided with the eliminator and a symmetrical elbow (ordered separately). Don't forget the o-ring 130.

Case 3: The oil mist eliminator is equipped with ODK1 kit Figure c)

- Install the oil mist eliminator on the rotary vane pump exhaust.
- On the pump oil casing, unscrew the gas ballast cover (2 screws) with an allen wrench, and remove the adjustment button, the spring and the sleeve.
- On the oil mist eliminator, remove the drain plug 11.
- Screw the connector 3 in the bottom of the OME 25 HP with a thin spanner 12 mm. Install the 4/6 Rilsan pipe on the connector and secure with the nut.
- Screw the elbow connector 1 into the oil case feedthrough without forget the jet 2 and install the 4/6 Rilsan on it.

OME 25 HP - OME 25 HP+

Cas 4: The oil mist eliminator is equipped with ODK2 kit **Figure d)**

- Install the oil mist eliminator on the rotary vane pump exhaust,
- On the pump oil casing, unscrew the gas ballast cover (2 screws) with an allen wrench, and remove the adjustment button, the spring and the sleeve.
- On the oil mist eliminator, remove the drain plug 11.
- Screw the connector 3 in the bottom of the OME 25 HP with a thin spanner 12 mm. Install the 4/6 Rilsan pipe on the connector and secure with the nut.
- Screw the connector 5 on the oil case feedthrough, and the elbow connector 1 on the valve 6 in the opposite side of the arrow; 2 then install the jet on the connector 1 and the Rilsan pipe.
- Unscrew the nut 8 on the valve and fit the right coil.
- Wire the connector 7.
- Connect the connector 7 and the coil 8.

CAUTION

These operations are made when the pump is stopped.

In four cases:

- The oil mist eliminator can be located far from the pump.
- Use a suitable diameter of pipe between pump and oil mist eliminator.

In all cases:

- **Connect the nipple marked with the «Pump 1» label on the exhaust side of the pump.**

If the oil mist eliminator is connected to a chimney or ventilating duct, check to be sure the pressure loss in this equipment does not exceed **375 Torr**.

II.6. OPERATING

Switch-on the pump. When working, oil and settlings are trapped by the filter cartridge until it will be clogged. In such case the relief valve should open when the inner pressure is exceeding the atmospheric pressure by 375 Torr (7 psi).

II.7. MAINTENANCE

WARNING

Each time the system is dismantled, take all necessary precautions to ensure safety and protection of personnel against possible toxicity, corrosion, and radioactivity of residues. Depending on the nature of the residue, we recommend:

- Purging the system with dry nitrogen before working on it.
- Wearing gloves, goggles and, if necessary, an oxygen mask.
- Thorough ventilation of the room and disassembly under a fume hood.
- Recovery of residue in appropriate containers. If necessary, have them destroyed by a competent organization.

OME 25 HP / OME 25 HP+

a) Cartridge saturation

If excessive fumes or droplets, or bursts of vapours appear at eliminator outlet, and if oil level appears through the sight glass, the cartridge is saturated.

The time taken to reach saturation point depends on the number of pumping operations, their frequency, the volume of pumped gas, and the kind of the oil used. When the cartridge is saturated, replace as follows:

a1) Draining the eliminator OME 25 HP/HP+

- Drain by removing the plug 11 and recover oil in appropriate containers.

The connection of the drain port to a circuit collectory expelled liquid ensures an automatic purge. In this case, connect the circuit collectory expelled liquid to a gas collector.

a2) When the OME 25 HP/HP+ is equipped with an oil drain kit ODK1 or ODK2

- Spray with compressed air to remove any obstructions.

b) Disassembly (OME 25 HP: figure f) ou (OME 25 HP+: figure g)

- Detach the eliminator from the pump and disassemble on a workbench.
- Unscrew the assembling screw 22: the filter cartridge 21 stays on the base 2, replace it.
- Remove the o-ring 9 from the base.
- Remove the equipped valve seat from the body 1.
- Unscrew the assembling screw 17 and remove the washer 15, the valve 16.

c) Oil drain kit removal

- Remove the pipe on the connector 3.
- Remove the DN25 D clamping ring and remove the OME.

d) Cleaning

CAUTION

Never clean the filter cartridge: always install a new one.

Elastomer seal 9 must always be replaced by new one.

After use in mineral or synthetic oil, clean the metal components with a mineral products based solvent such a **AXAREL** ⁽¹⁾, **CARECLEAN** ⁽²⁾, **PREMACLEAN** ⁽³⁾, **NAPHTESOL** ⁽⁴⁾. Proceed as follows:

- Clean when cold or hot (max. 45°C) by dipping or using a cloth.
- Vacuum dry in a ventilated oven and.
- **The component must be cleaned a second time with alcohol.**

After use in (perfluorinate) synthetic oil, clean the metal components in a solvent such as **GALDEN S 90** ⁽⁵⁾ and proceed as follows:

- Clean when cold by dipping or using a cloth.
- Dry the components in the air or with compressed air.

After use in (non-perfluorinate) synthetic or mineral oil, clean the metal components with a solvent such as alcohol and proceed as follows:

- Clean when cold by dipping or using a cloth.
- Dry the components in the air.
- Industrial washing solutions can also be used. The cleaning operation should be followed by vacuum drying.

OME 25 HP - OME 25 HP+

e) Reassembly

- Install the washer 15 on a new valve 16.
- Position on the valve seat 14 the valve and its washer; **the valve flat face must rest on the valve seat.**
- Install the spring 20 on the washer, than assemble the ressort support 18 with screws 17.
- Position a new cartridge 21 in the body 2.
- Center the equipped valve seat on the cartridge.
- Assemble the body 1 and secure with the mounting screws 22 and 23.
- Connect the eliminator to the pump exhaust port install the oil kit if necessary (see paragraph II.5.).

(1)... DUPONT DE NEMOURS registered trademark

(2)... CASTROL registered trademark

(3)... DOW registered trademark

(4)... NIPPON OIL CORPORATION registered trademark

(5)... MONTEDISON registered trademark

I.8. APPLICATIONS NOT RECOMMENDED

Use of an oil mist eliminator is not recommended in the following cases: drying, freedrying, pumping condensable gases, impregnation with polymerizable resins, and debubbling monomers (risk of product condensation into the pump and quick cartridge clogging by pumped gases).

Please contact customer service to study a solution.

⚠ WARNING

Filter cartridges are flammable: do not use eliminators when pumping flammable products such as oxygen or silane.

The standard oil mist eliminator must also not be used for pumping corrosive products or for microelectronic and chemical applications. (cartridge compatibility with some corrosive products).

It must be essentially used with rotary vane pumps type 3 to 13 cfm I and SD series.

I.9. SPARE PARTS

Parts which must be replaced each time the cartridge is changed

REFERENCE	NUMBER	PART NAME	PART NUMBER	
			OME 25 HP	OME 25 HP+
21	1	Filter cartridge equipped with 2 O-rings	100522	111646
16	1	Diaphragm	054196	
9	1	O-ring	083539	
3	1	Oil level sight glass	083546	
11	1	Equipped drain plug	101575	

OME 25 HP / OME 25 HP+

SPARE PARTS FOR ODK1, ODK2 OIL DRAIN KITS

REFERENCE	NUMBER	PART NAME	PART NUMBER
2	1	Jet (ODK1, ODK2)	102832
8	1	Coil 230V 50/60 Hz	103552
8	1	Coil 115V 60 Hz	038122
8	1	Coil 100V 50/60 Hz	038126
8	1	Coil 200V 50/60 Hz	038125
8	1	Coil 24V DC	038066

OME 25 HP - OME 25 HP+

FIGURES

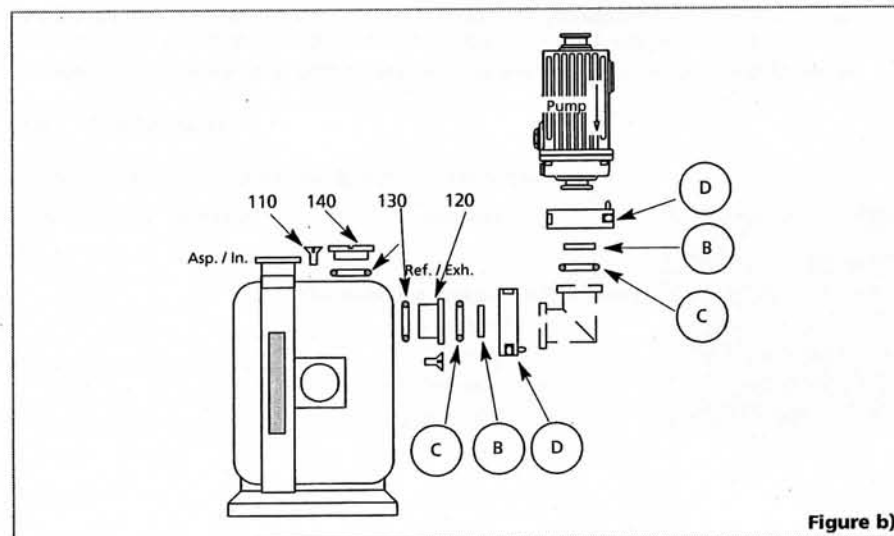
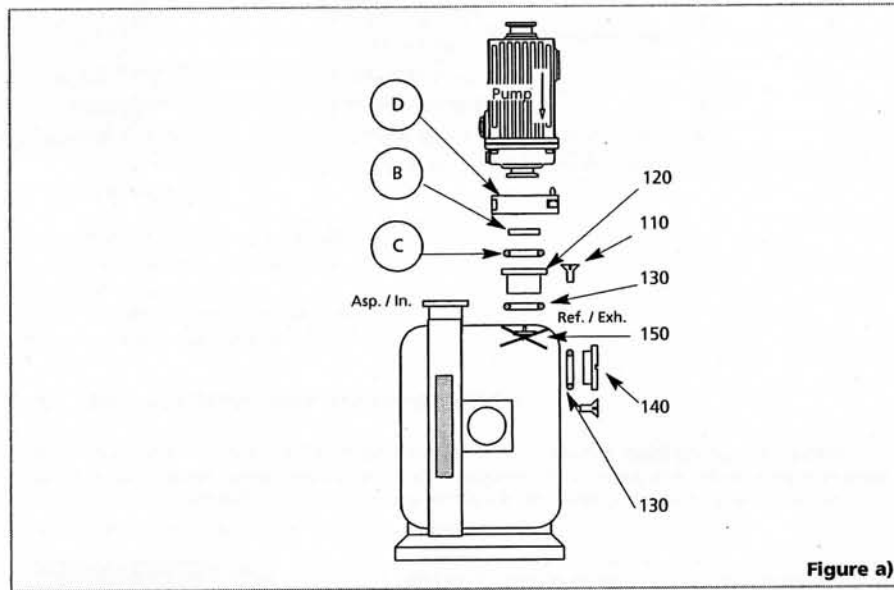

OME 25 HP / OME 25 HP+

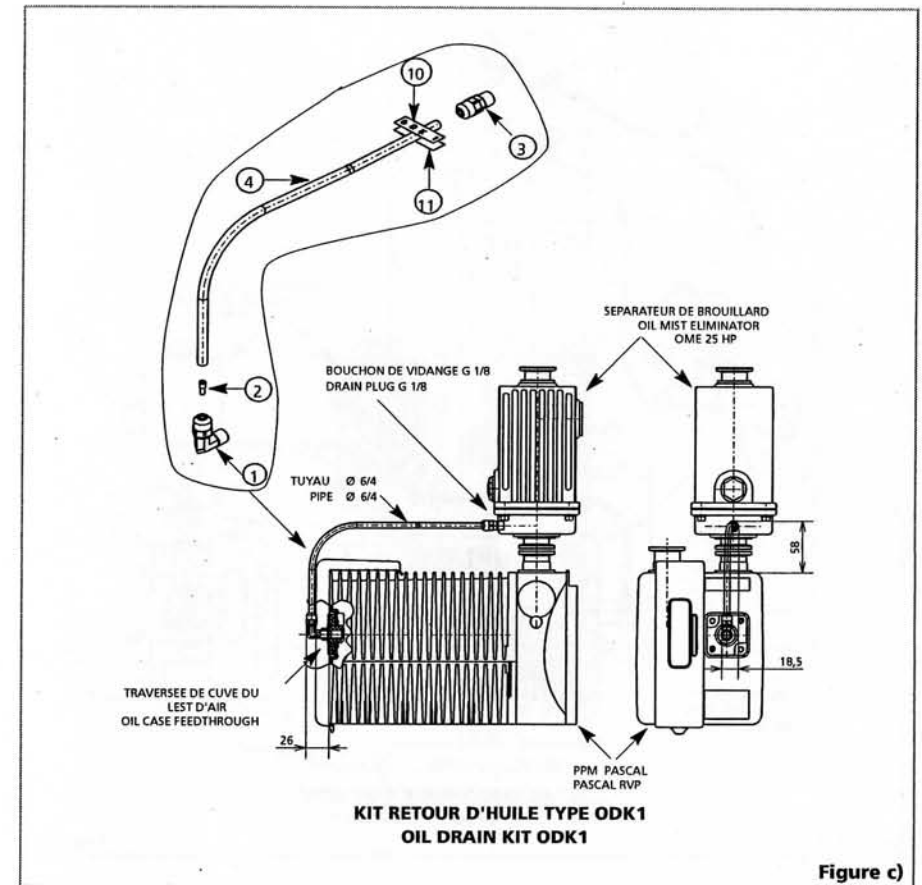

OME 25 HP - OME 25 HP+

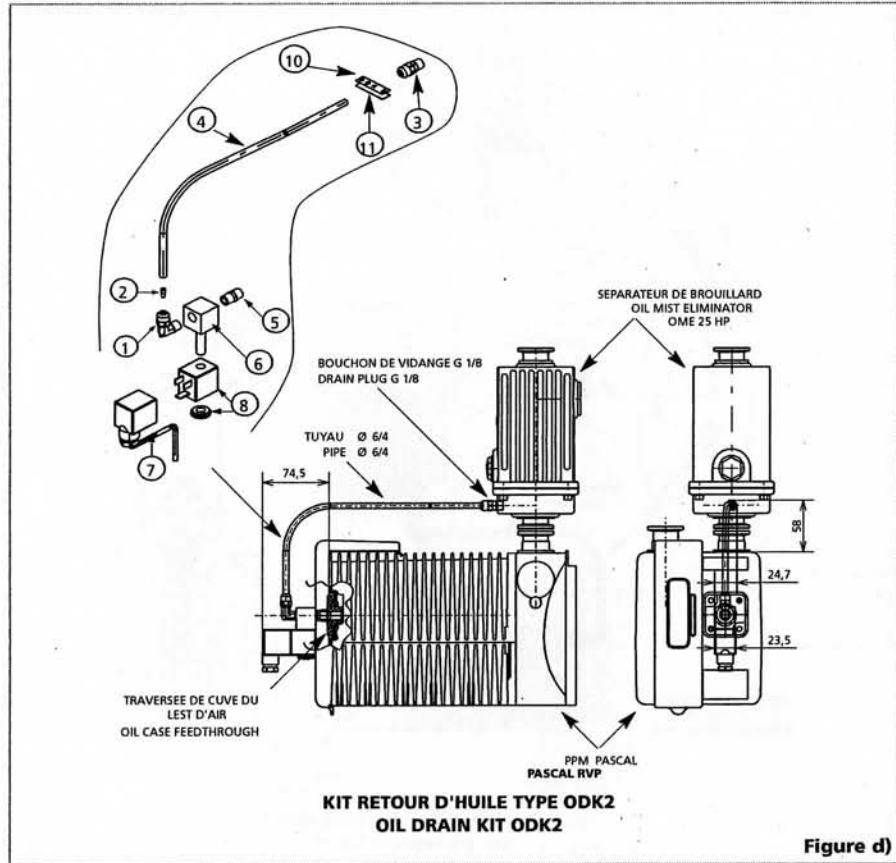

OME 25 HP / OME 25 HP+

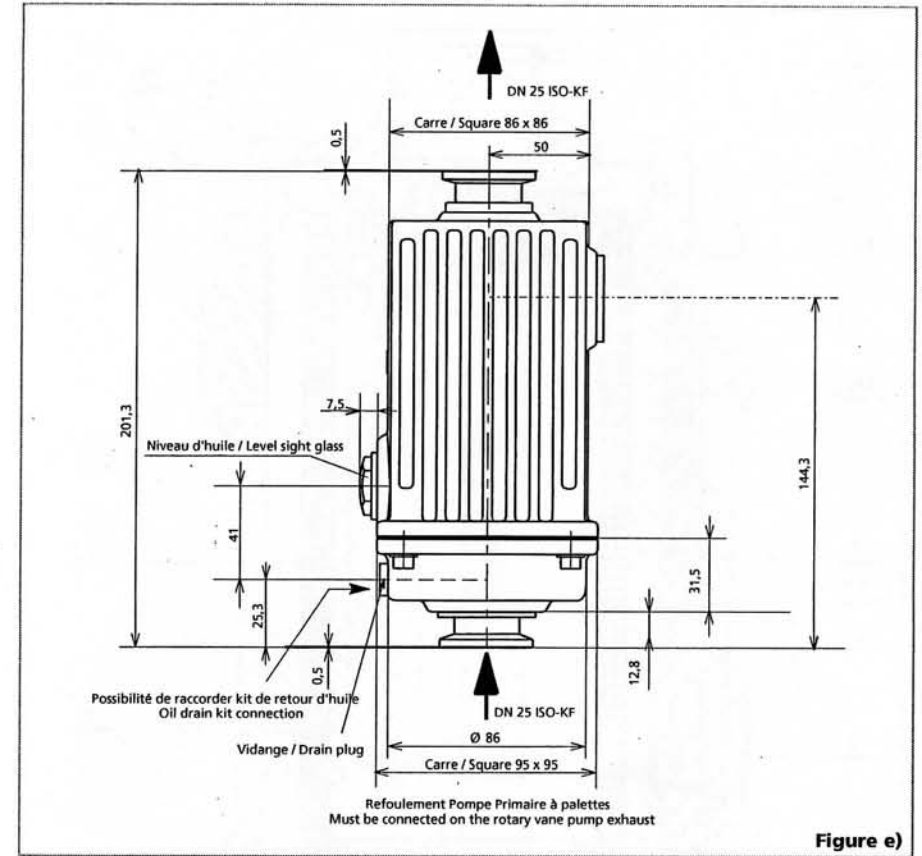

OME 25 HP - OME 25 HP+

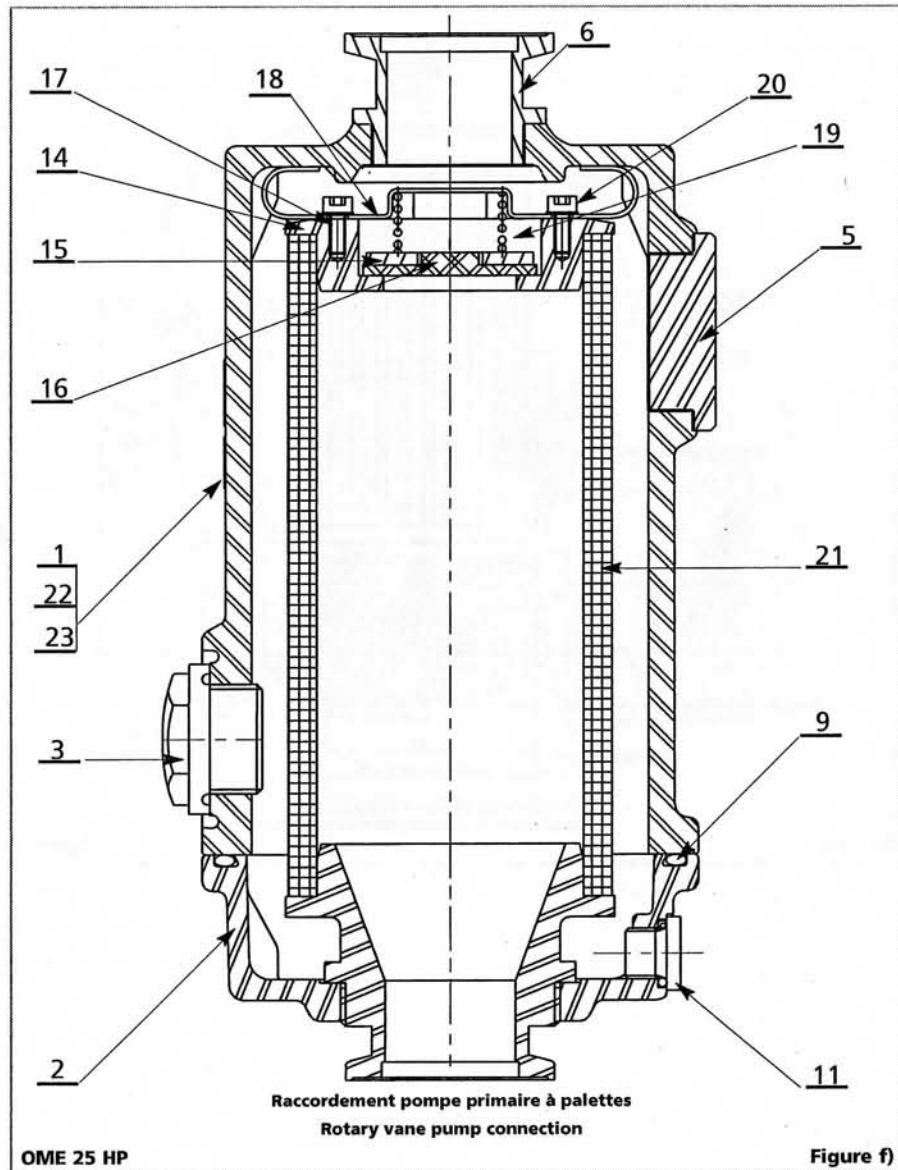

OME 25 HP / OME 25 HP+

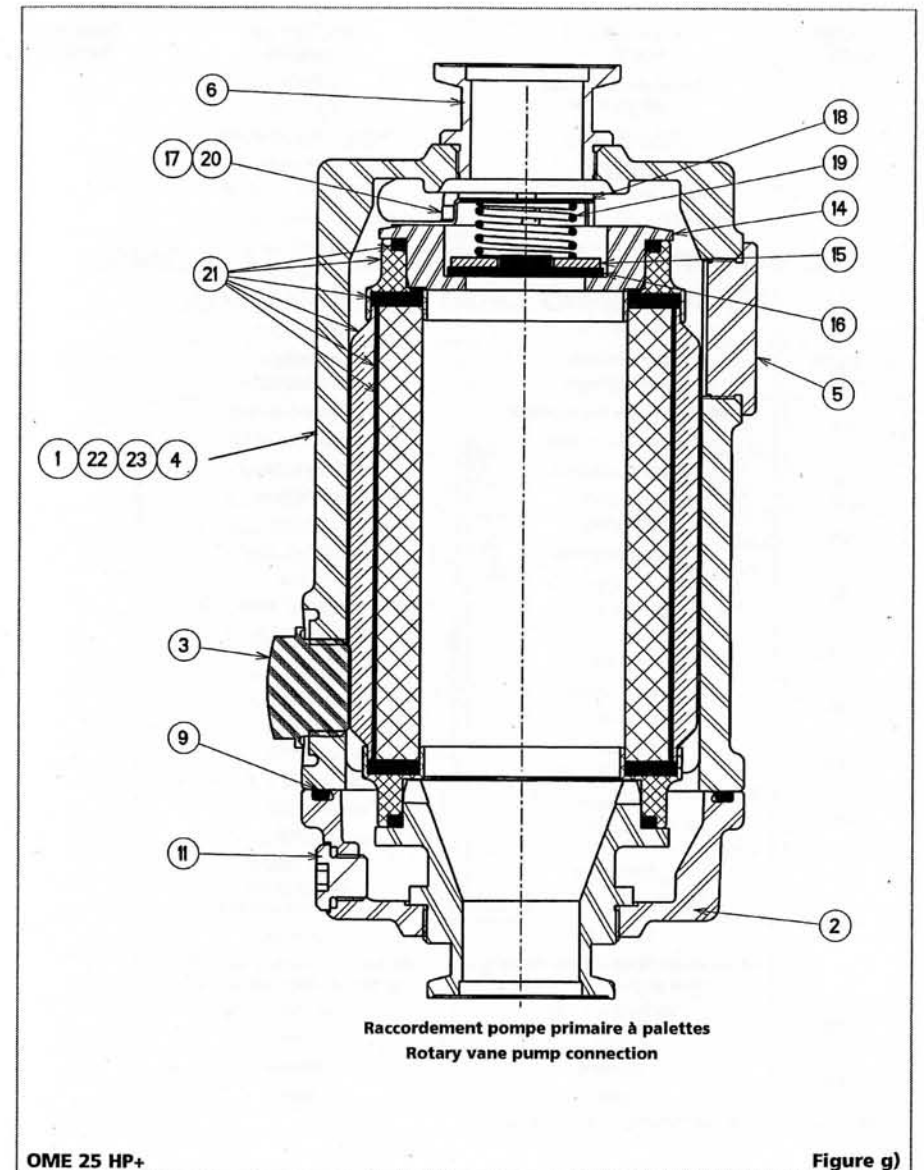

OME 25 HP - OME 25 HP+

NOMENCLATURE OME 25 HP/HP+

REPÈRE REF.	DESIGNATION MATERIAU	DESCRIPTION MATERIAL	QUANTITE NUMBER
1	Corps du séparateur aluminium	Body aluminium	1
2	Corps inférieur aluminium	Base of the separator aluminium	1
3	Voyant de niveau + joint polyamide + élastomère NBR*	Sight glass + O-ring polyamid + elastomer NBR*	1
5	Obturbateur aluminium	Blank off flange aluminium	1
6	Embout aluminium	Nipple aluminium	1
9	Joint torique élastomère NBR *	O-ring elastomer NBR*	1
11	Bouchon 1/8 + Joint torique aluminium + NBR	Plug 1/8 + O-ring aluminium +NBR	1
14	Support soupape aluminium	Valve seat aluminium	1
15	Rondelle acier inoxydable	Washer stainless steel	1
16	Soupape élastomère FPM*	Valve elastomer FPM*	1
17	Vis CHC M 8 x 3 acier	Screw CHC M8 x 3 steel	2
18	Ressort support acier	Spring steel	1
19	Ressort acier	Spring steel	1
20	Rondelle acier	Washer steel	2
21	Cartouche époxy + fibre de verre	Cartridge epoxy binder + glass microfibers	1
	Cartouche résine phénolique + fibre de verre + fibre polyester et nitrile	Cartridge Borosilicate glass + fiber PF + polyester fiber/NBR binder	1
22	Vis CHC M 5 x16 acier	Screw CHC 5 x16 steel	4
23	Rondelle acier	Washer steel	4

* suivant norme NFT 40-002/ following norme NFT 40-002.

OME 25 HP / OME 25 HP+

NOMENCLATURE KIT DE RETOUR D'HUILE ODK1 / NOMENCLATURE ODK1 OIL DRAIN KIT

REPÈRE REF.	DESIGNATION MATERIAU	DESCRIPTION MATERIAL	QUANTITE NUMBER
1	Raccord équerre mâle	Mâle elbow connector	1
2	Gicleur	Jet	1
3	Raccord un. mâle	Mâle connector	1
4	Tuyau rilsan (naturel)	Rilsan pipe	35 cm

NOMENCLATURE KIT DE RETOUR D'HUILE ODK2 / NOMENCLATURE ODK2 OIL DRAIN KIT

REPÈRE REF.	DESIGNATION MATERIAU	DESCRIPTION MATERIAL	QUANTITE NUMBER
1	Raccord équerre mâle	Mâle elbow connector	1
2	Gicleur	Jet	1
3	Raccord un. mâle	Mâle connector	1
4	Tuyau rilsan (naturel)	Rilsan pipe	35 cm
5	Raccord mam. mâle	Mâle connector	1
6	Electrovanne vide	Electrovalve	1
7	Câble électrique et connecteur	Equipped cable and connector	1
8	Bobine minisol 230 V 50/60 Hz	Coil 230 V 50/60 Hz	1
8	Bobine minisol 115 V 60 Hz	Coil 115 V 60 Hz	1
8	Bobine minisol 100 V 50/60 Hz	Coil 100 V 50/60 Hz	1
8	Bobine minisol 200 V 50/60 Hz	Coil 200 V 50/60 Hz	1
8	Bobine minisol 24 V DC	Coil 24 V DC	1