

# 5 to 21 m<sup>3</sup>/h PASCAL Series I, SD, C1, C2 Series

## ROTARY VANE PUMPS

### User's manual

Chemtech Scientific provides access to this content as a courtesy.

We do not own the content contained in this document.

All rights and credit go directly to its rightful owners.

[www.chemtechsci.com](http://www.chemtechsci.com)

Call us at: 484-424-9415

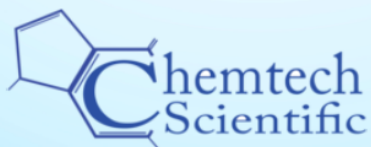



Since it was founded in 1962, Alcatel High Vacuum Technology has been devoted to supplying industries using vacuum technologies with high quality equipment. Its vane rotary pumps, designed to offer maximum reliability are the basis of its success and world-wide reputation.

In order to provide constant improvements of its products and satisfy very diverse customer requirements, Alcatel has invested in an ultra-modern flexible manufacturing facility. This set of adapted and automated machining equipment has placed Alcatel among the world-wide leaders in the manufacture of rotary vane pumps.

In a world where adapting to customer requirements, quality, quick response and service are operational standards, Alcatel has equipped itself with exceptional resources in R&D, manufacturing and quality, in order to be able to reach its goal: total quality. Alcatel High Vacuum Technology has been ISO 9001 certified since 1993.

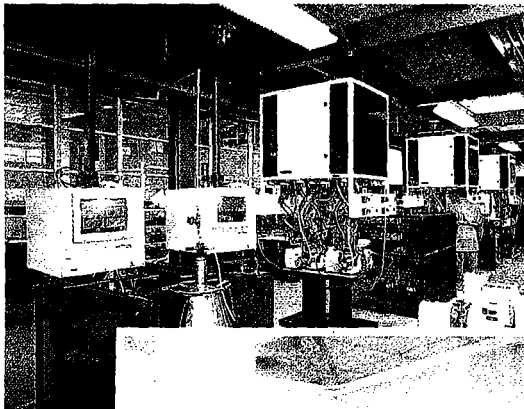

Alcatel's commitment to supplying high quality products, has contributed to improving the performance and reliability of the equipment in which they are used.

With our experienced personal, our knowledge of vacuum technologies and our range of high performance products, we invite you to consider us as an integral part of your development team, to help define improved answers to your needs. Our international Sales and Support network is ready to assist you in this way.

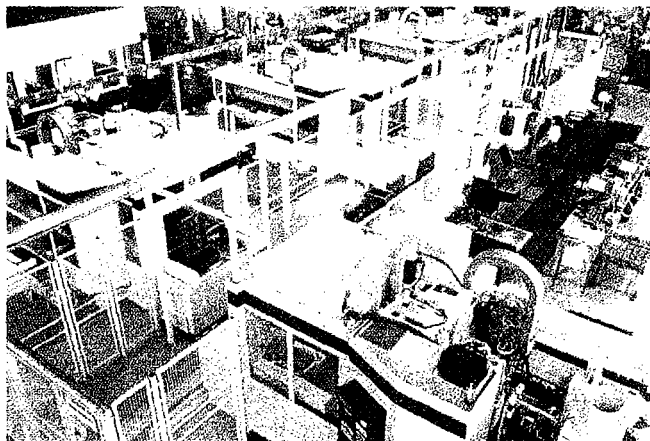
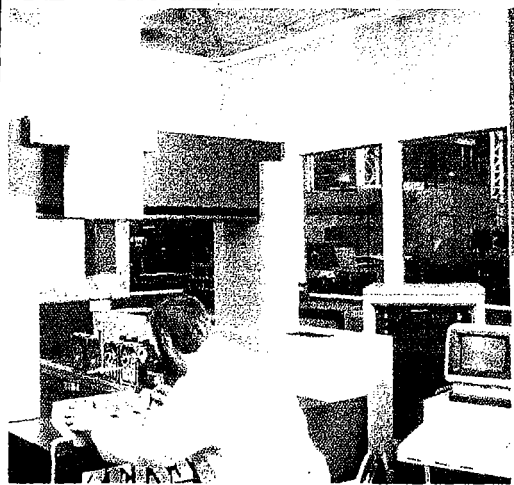

# Welcome

## Rotary vane pumps

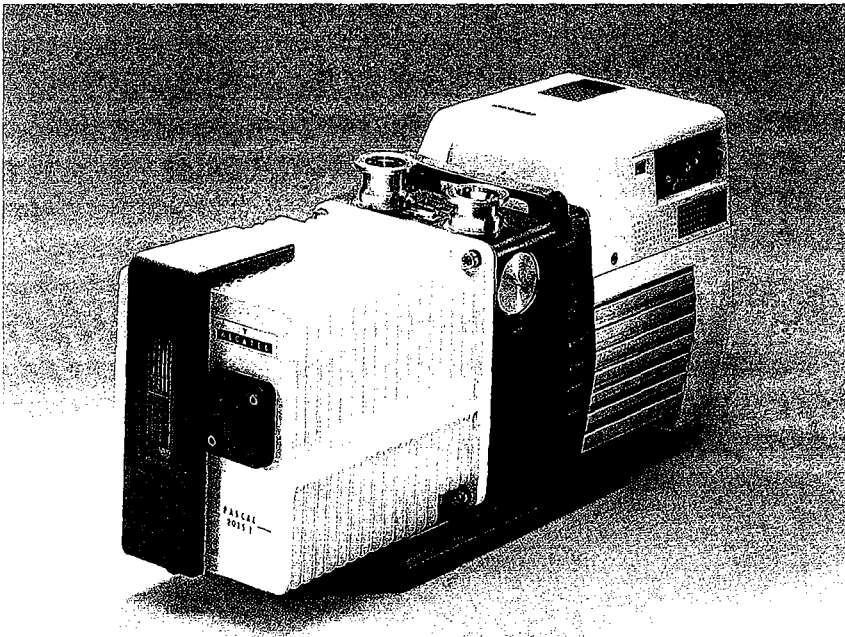

Dear customer,

You have just bought an Alcatel rotary vane pump. We would like to thank you and are proud to count you among our customers.

This product is a result of experience acquired over many years by Alcatel in the design of rotary vane pumps.

### APPLICATIONS:

- RESEARCH AND DEVELOPMENT  
Physics and chemistry laboratories, etc.
- INDUSTRY  
Foodstuffs (freeze-drying), Pharmaceuticals,  
Electronic tube manufacture,  
Metallurgy, Drying systems,  
Refrigeration systems, Chemical industry, etc.
- INSTRUMENTATION  
Mass spectrometry, Centrifuges,  
Electronic microscopes, Leak detection systems, etc.
- VARIOUS SEMICONDUCTOR PROCESSES



**We suggest that you read this manual, particularly the chapter on installation and operation, before you start to use this pump so that you can obtain optimum levels of performance and complete satisfaction from this equipment.**

*Contents*



# Contents

## The PASCAL series 5 to 21 m<sup>3</sup>/h

Presentation of the product range . . . . .	54
Operating principle of a rotary vane pump . . . . .	56
Technical characteristics . . . . .	59
Pump dimensions . . . . .	62
Accessories . . . . .	63

Presentation

## Installation and connections

Safety instructions . . . . .	65
Table of recommended oils . . . . .	67
Filling with oil . . . . .	68
Mechanical connections . . . . .	69
Electrical connections . . . . .	71
Motor protection . . . . .	72

Start-up

## Operation

Precautions . . . . .	75
Operating temperature . . . . .	75
Before starting up the pump . . . . .	75
Start-up . . . . .	76
Operation of gas ballast . . . . .	77
Particular uses . . . . .	79
Oxygen pumping . . . . .	81
High pressure pumping and cycling . . . . .	82

Operation

## Maintenance

Precautions . . . . .	83
Troubleshooting and corrective actions . . . . .	84
Maintenance frequency . . . . .	87
Draining the oil . . . . .	87
Flushing the pump . . . . .	88
Change of type of oil . . . . .	88
Replacement of front shaft seal . . . . .	89
Tools and consumable products . . . . .	90
Disassembling the pump . . . . .	91
Cleaning components . . . . .	94
Replacement of all shaft seals . . . . .	95
Reassembling the pump . . . . .	96
Spare parts lists . . . . .	149

Maintenance

## Presentation of the product range

**A wide range  
Specific solutions adapted to various  
applications**

Alcatel oil seal rotary vane pumps are used in all vacuum technology applications.

They can be used on their own to achieve a maximum vacuum of  $10^{-3}$  Torr ( $10^{-3}$  mbar), or in pumping assemblies, e.g. at the exhaust of a diffusion pump or turbomolecular pump.

- SD series** **Standard pumps for several purposes (non-corrosive applications).**  
Manufacture of light bulbs, production of TV tubes, manufacture of electronic tubes, metallurgy, centrifuges, etc.
- I series** **Pumps designed to meet the requirements of analytical instrumentation and R&D.**  
Mass spectrometer, electronic microscopes, GC/MS, LC/MS, gas analyzers, leak detectors, sterilizers, etc.
- C1 series** **Pumps suited to the pumping of corrosive gases.**  
R&D, laboratories, freeze-drying, pumping of solvents, etc.
- C2 series** **Pumps with increased resistance to meet the requirements of the more aggressive processes of the semiconductor industry.**  
Ion implantation, sputtering, etc.
- H1 series** **Sealed pumps offering maximum tightness.**  
Pumping of pure or precious gases.

Nom. fl. rate	m <sup>3</sup> /h	5	10	15	21
I series	2 stages	2005I	2010I	2015I	2021I
SD series	1 stage	1005SD	1010SD	1015SD	1021SD
	2 stages	2005SD	2010SD	2015SD	2021SD
C1 series	1 stage	1005C1	1010C1	1015C1	1021C1
	2 stages	2005C1	2010C1	2015C1	2021C1
C2 series	2 stages		2010C2	2015C2	2021C2
H1 series	2 stages	2005H1		2015H1	

# 5 to 21 m<sup>3</sup>/h rotary vane pumps. I, SD, C1, C2 Pascal series

## Précautions

Four 5 to 21 m<sup>3</sup>/h pump models with the following main characteristics:

- A **direct drive motor**, making them very compact.
- An electrically insulated **fold-away handle** is used for easy carrying.
- An **anti-suckback system** ensures the tightness of the pump during accidental or voluntary shutdowns.
- A **gas ballast** enables the pumping of condensable vapours (except for C2 series).
- The universal three-phase or single-phase **motor** can be disassembled **independently** of the rest of the pump, without the need to drain the oil case.
- On the oil case, a **vertical sight glass** can be used to inspect the oil level easily when filling the tank and during the operation of the pump.
- A **neutral gas purge** is used to degas oil and dilute pumped gases on C2 series models.

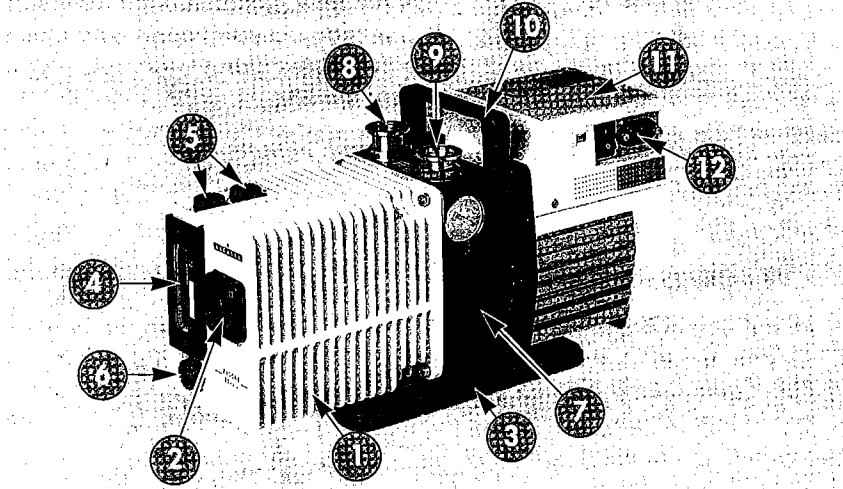

- |                          |                         |
|--------------------------|-------------------------|
| 1. Oil case              | 7. Frame                |
| 2. Gas ballast control   | 8. Inlet end fitting    |
| 3. Base                  | 9. Exhaust end fitting  |
| 4. Oil level sight glass | 10. Fold-away handle    |
| 5. Filling plugs         | 11. Electric motor      |
| 6. Draining plug         | 12. IEC electric socket |

The inlet and exhaust end fittings are PNEUROP ISO-KF standardized. They are fitted vertically on the pump at delivery but can be positioned on the horizontal openings if required by operating conditions. They can also be used to connect many of our accessories (see page 63).

The main replacement parts are interchangeable: This enables easier disassembly-assembly operations and replacement without changing the pump's performance.

Various accessories can be used to adapt the pump to meet the requirements of your application.

The moulded aluminium pump frame supports the pumping module and the motor. All the parts of the pumping module in contact with gases are free of zinc, copper and cadmium.

The other construction materials include cast iron, aluminium alloy, stainless steel, fluorocarbons (FPM), nitril (NBR) and chemically resistant polymers.

# Operating principle of the rotary vane pump

## Single-stage rotary vane pump

This is a volumetric pump, with a functional part composed of:

- A hollow cylindrical stator with inlet and exhaust valves.
- A rotor mounted eccentrically inside the stator for pumping.
- Two vanes sliding in the rotor, forced against the stator by centrifugal force and springs.

The pumping cycle is given below:

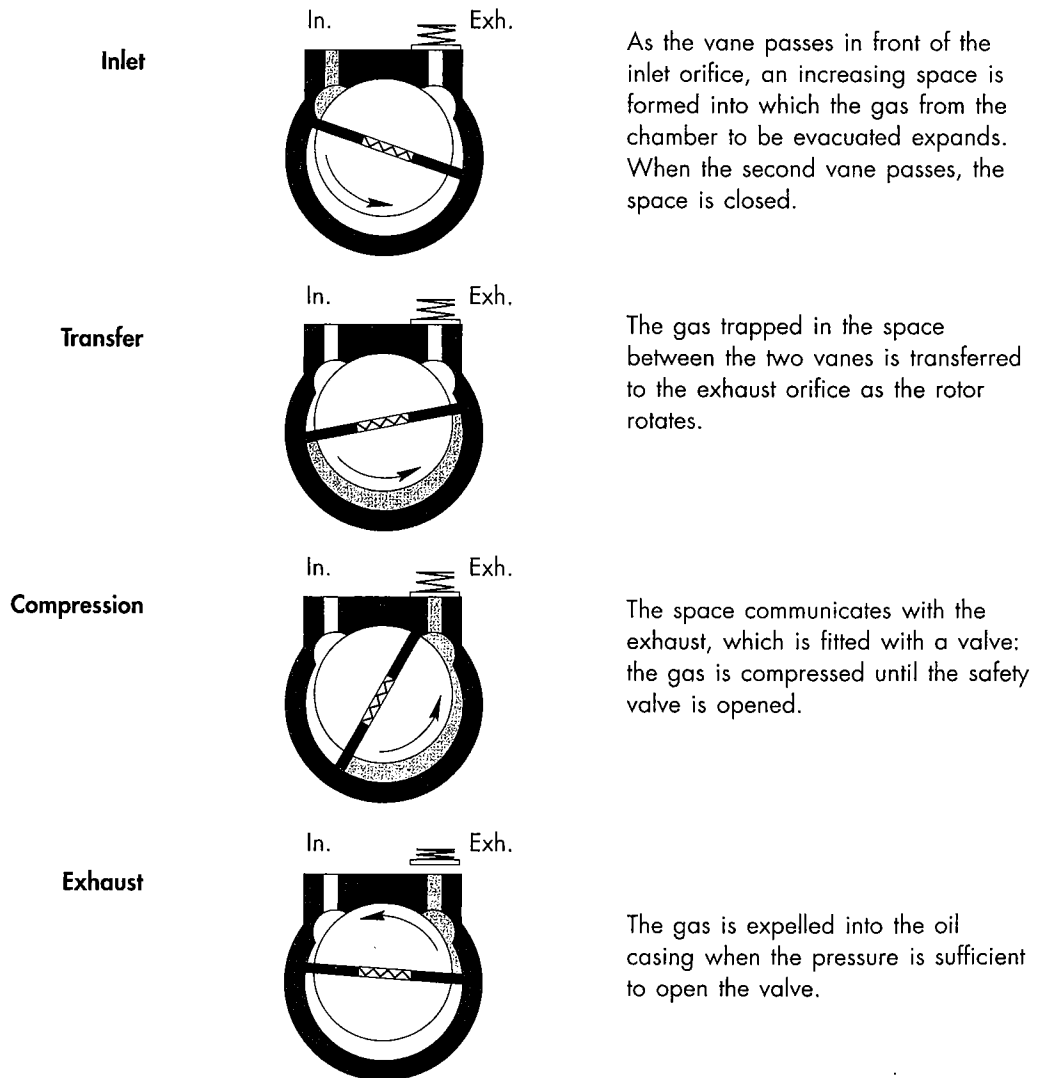

**Application** Single stage rotary vane pumps are the best choice for continuous pressures above 1.0 Torr (1,3 mbar), as well as applications where large amounts of condensable gases are present.



## Two-stage rotary vane pump

To improve the backing pressure and flowrate at low pressure, two stages are connected in series. The second is similar to the first both structurally and operationally. The gases pulled in by the first (low pressure) stage are transferred to the second (high pressure) stage and discharged through the high pressure (HP) valve.

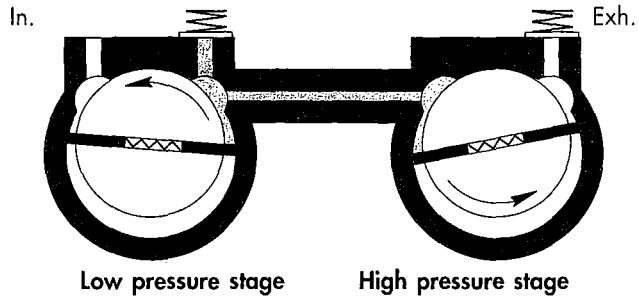

### Application

Two stage rotary vane pumps are the best choice for application requiring an ultimate vacuum as low as  $10^{-3}$  Torr ( $1.33 \times 10^{-3}$  mbar).

Note : when operating a two stage vane pump continuously, greater than half an hour, above 1.0 Torr, the unit should be equipped with an oil mist eliminator and oil return system, see oil draining kit ([page 63](#)), or a single stage pump should be used.

# Oil

- Its function** Oil has several important functions in the pump:
- It lubricates mechanical components (bearings, seals, rotor, vanes, etc.).
  - It makes moving parts relatively tight by limiting internal leakage.
  - It carries away the heat produced by the compressed gases.

**Choosing the right oil** Not all oils produce the same ultimate pressure in a given pump. Ultimate pressure depends on the saturated vapour pressure of the oil, its viscosity and its ability to dissolve gases.

Good pumping conditions are related to the type of oil used.

The choice depends on:

- Expected pump performance.
- Chemical aggression and corrosion of pumped gases.
- Accessories used.
- Desired maintenance intervals and total operating cost.

ALCATEL has selected various types of oil for its pumps (*see page 67*).

## Lubrication and anti-noise device

The pump is equipped with a **lubrication** system which regulates the oil flow rate required in the vacuum pump. In addition this system also ensures the gassing of the lubrication oil and therefore **the low noise level** of the pump.

## Gas ballast

When condensable vapours are being pumped, gas is compressed beyond its saturated vapour pressure in the "compression" phase and can condense, impairing pump performance.

The gas ballast can be used to inject a certain quantity of air (neutral or dry gas) into the last stage of the pump during the "compression" phase so that the partial pressure of the pumped gas is less than its saturated vapour pressure at the temperature of the pump. Condensation is therefore impossible if this limit is not reached. The maximum admissible vapour pressure is obtained at pump inlet for this value.

At the end of "compression", the pressure in the exhaust chamber is greater than atmospheric pressure. An anti-suckback device (valve + spring) prevents the gases and oil from being drawn back into the inlet.

The saturated vapour pressure of a body is higher when the system is hot than when it is cold; therefore, the pump must reach operating temperature before pumping condensable vapours.

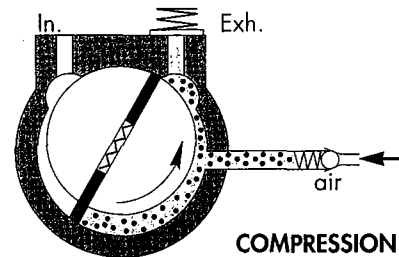

- Using the gas ballast increases the ultimate pressure of the pump as well as the temperature.
- The gas ballast control, located at the front of the oil case cannot be used to set the gas injection flow rate.
- When the gas ballast control is open, the pump is not tight when stopped. To guarantee this tightness, install an automatic gas ballast.

## Technical characteristics

### For analytical instrumentation: I Series Two-stage pumps

Characteristics	Unit	2005 I		2010 I		2015 I		2021 I	
Frequency	Hz	50	60	50	60	50	60	50	60
Number of stages		2		2		2		2	
Rotation speed	rpm	1500	1800	1500	1800	1500	1800	1500	1800
Nominal flow rate	m <sup>3</sup> /h	5.4	6.5	9.7	11.6	15	18	20.7	24.8
	cfm		3.8		6.8		10.6		14.6
Flow rate Pneurop method	m <sup>3</sup> /h	4.8	5.7	8.5	10.2	12.5	15	16.5	20
	cfm		3.4		6		8.8		11.8
Partial ultimate pressure* (with Alcatel 120 oil)	Torr/mbar /Pa	7.5.10 <sup>-5</sup> / 1.10 <sup>-4</sup> 1.10 <sup>-2</sup>							
Ultimate pressure with gas ballast closed	Torr/mbar /Pa	1.5.10 <sup>-3</sup> / 2.10 <sup>-3</sup> 2.10 <sup>-1</sup>							
Ultimate pressure with gas ballast open	Torr/mbar /Pa	7.5.10 <sup>-3</sup> / 1.10 <sup>-2</sup>							
Oil capacity	l	0.83		0.950		0.950		0.98	
Maximum water vapour pumping capacity (Ballast flowrate 1.1 m <sup>3</sup> /h)	mbar Pa	35	25	20	15	12	10	7	7
Water vapour pumping capacity	g/h	120	110	125	100	110	100	90	90
Weight (pump + motor)**	kg (lbs)	25 (55)		26 (57)		27 (59.5)		28 (62)	
Inlet and exhaust end fittings	ISO-KF	DN 25							

### For industry: SD Series Two-stage pumps

Characteristics	Unit	2005 SD		2010 SD		2015 SD		2021 SD	
Frequency	Hz	50	60	50	60	50	60	50	60
Number of stages		2		2		2		2	
Rotation speed	rpm	1500	1800	1500	1800	1500	1800	1500	1800
Nominal flow rate	m <sup>3</sup> /h	5.4	6.5	9.7	11.6	15	18	20.7	24.8
	cfm		3.8		6.8		10.6		14.6
Flow rate Pneurop method	m <sup>3</sup> /h	4.8	5.7	8.5	10.2	12.5	15	16.5	20
	cfm		3.4		6		8.8		11.8
Partial ultimate pressure* with Alcatel 120 oil	Torr/mbar /Pa	7.5.10 <sup>-5</sup> / 1.10 <sup>-4</sup> 1.10 <sup>-2</sup>							
Ultimate pressure with gas ballast closed	Torr/mbar /Pa	1.5.10 <sup>-3</sup> / 2.10 <sup>-3</sup> 2.10 <sup>-1</sup>							
Ultimate pressure with gas ballast open	Torr/mbar /Pa	7.5.10 <sup>-3</sup> / 1.10 <sup>-2</sup>							
Oil capacity	l	0.83		0.950		0.950		0.98	
Weight (pump + motor)**	kg (lbs)	25 (55)		26 (57)		27 (59.5)		28 (62)	
Maximum water vapour pumping capacity (Ballast flowrate 1.1 m <sup>3</sup> /h)	mbar Pa	35	25	20	15	12	10	7	7
Water vapour pumping capacity	g/h	120	110	125	100	110	100	90	90
Inlet and exhaust end fittings	ISO-KF	DN 25							

\* Partial ultimate pressure measured according to Pneurop 6602 specifications. It may vary if other oils are used (See page 67).

\*\* These values are for pumps equipped with universal single-phase motors.

Note: The pressure measurements were made with a capacitive diaphragm pressure gauge measuring a total pressure in the absence of a cold trap. Measurements using a Pirani type gauge can give different pressure values.

**Corrosive applications:  
C1 Series**

**Two-stage pumps**

Characteristics	Unit	2005 C1		2010 C1		2015 C1		2021 C1	
Frequency	Hz	50	60	50	60	50	60	50	60
Number of stages		2		2		2		2	
Rotation speed	rpm	1500	1800	1500	1800	1500	1800	1500	1800
Nominal flow rate	m <sup>3</sup> /h	<b>5.4</b>	<b>6.5</b>	<b>9.7</b>	<b>11.6</b>	<b>15</b>	<b>18</b>	<b>20.7</b>	<b>24.8</b>
	cfm		3.8		6.8		10.6		14.6
Flow rate Pneurop method	m <sup>3</sup> /h	<b>4.8</b>	<b>5.7</b>	<b>8.5</b>	<b>10.2</b>	<b>12.5</b>	<b>15</b>	<b>16.5</b>	<b>20</b>
	cfm		3.4		6		8.8		11.8
Partial ultimate pressure* with Alcatel 120 oil	Torr/mbar /Pa	<b>7.5.10<sup>-5</sup> / 1.10<sup>-4</sup></b> 1.10 <sup>-2</sup>							
Ultimate pressure with gas ballast closed	Torr/mbar /Pa	<b>1.5.10<sup>-3</sup> / 2.10<sup>-3</sup></b> 2.10 <sup>-1</sup>							
Ultimate pressure with gas ballast open	Torr/mbar /Pa	<b>7.5.10<sup>-3</sup> / 1.10<sup>-2</sup></b> 1							
Oil capacity	l	0.83		0.950		0.950		0.98	
Weight (pump + motor)**	kg (lbs)	25 (55)		26 (57)		27 (59.5)		28 (62)	
Maximum water vapour pumping capacity (Ballast flowrate 1.1 m <sup>3</sup> /h)	mbar	<b>35</b>	<b>25</b>	<b>20</b>	<b>15</b>	<b>12</b>	<b>10</b>	<b>7</b>	<b>7</b>
	Pa	35.10 <sup>2</sup>	25.10 <sup>2</sup>	2.10 <sup>3</sup>	15.10 <sup>2</sup>	12.10 <sup>2</sup>	1.10 <sup>3</sup>	7.10 <sup>2</sup>	7.10 <sup>2</sup>
Water vapour pumping capacity	g/h	120	110	125	100	110	100	90	90
Inlet and exhaust end fittings	ISO-KF	DN 25							

**Corrosive applications:  
C2 Series**

**Two-stage pumps**

Characteristics	Unit	2010 C2		2015 C2		2021 C2	
Frequency	Hz	50	60	50	60	50	60
Number of stages		2		2		2	
Rotation speed	rpm	1500	1800	1500	1800	1500	1800
Nominal flow rate	m <sup>3</sup> /h	<b>9.7</b>	<b>11.6</b>	<b>15</b>	<b>18</b>	<b>20.7</b>	<b>24.8</b>
	cfm		6.8		10.6		14.6
Flow rate Pneurop method	m <sup>3</sup> /h	<b>8.5</b>	<b>10.2</b>	<b>12.5</b>	<b>15</b>	<b>16.5</b>	<b>20</b>
	cfm		6		8.8		11.8
Partial ultimate pressure* with Alcatel 113 oil	Torr/mbar Pa	<b>3.75.10<sup>-4</sup> / 5.10<sup>-4</sup></b> 5.10 <sup>-2</sup>					
Ultimate pressure	Torr/mbar Pa	<b>1.5.10<sup>-3</sup> / 2.10<sup>-3</sup></b> 2.10 <sup>-1</sup>					
Oil capacity	l	0.950		0.950		0.98	
Weight (pump + motor)**	kg (lbs)	26 (57)		27 (59.5)		28 (62)	
Inlet and exhaust end fittings	ISO-KF	DN 25					

\* Partial ultimate pressure measured according to Pneurop 6602 specifications. It may vary if other oils are used (See page 67).

\*\* These values are for pumps equipped with universal single-phase motors.

Note: The pressure measurements were made with a capacitive diaphragm pressure gauge measuring a total pressure in the absence of a cold trap. Measurements using a Pirani type gauge can give different pressure values.

## For industry: SD Series

### Single-stage pumps

Characteristics	Unit	1005 SD		1010 SD		1015 SD		1021 SD	
Frequency	Hz	50	60	50	60	50	60	50	60
Number of stages									
Rotation speed	rpm	1500	1800	1500	1800	1500	1800	1500	1800
Nominal flow rate	m <sup>3</sup> /h	<b>5.4</b>	<b>6.5</b>	<b>9.7</b>	<b>11.6</b>	<b>15</b>	<b>18</b>	<b>20.7</b>	<b>24.8</b>
	cfm		3.8		6.8		10.6		14.6
Flow rate Pneurop method	m <sup>3</sup> /h	<b>4.8</b>	<b>5.5</b>	<b>8.5</b>	<b>10</b>	<b>12.5</b>	<b>15</b>	<b>16.5</b>	<b>20</b>
	cfm		3.2		5.8		8.8		11.8
Ultimate pressure* with gas ballast closed	Torr/mbar /Pa	$3.75 \cdot 10^{-2} / 5 \cdot 10^{-2}$							
Ultimate pressure* with gas ballast open	Torr/mbar /Pa	$3 / 4$ $4 \cdot 10^2$				$5.25 / 7$ $7 \cdot 10^2$			
Oil capacity	l	1.1		1.0		1.0		1.0	
Weight (pump + motor)**	kg (lbs)	21 (46)		22 (48)		24.5 (54)		25 (55)	
Maximum water vapour pumping capacity (Ballast flowrate 1.1 m <sup>3</sup> /h)	mbar	<b>30</b>	<b>25</b>	<b>40</b>	<b>35</b>	<b>35</b>	<b>30</b>	<b>25</b>	<b>22</b>
	Pa	$3 \cdot 10^3$	$25 \cdot 10^2$	$4 \cdot 10^3$	$35 \cdot 10^2$	$35 \cdot 10^2$	$3 \cdot 10^3$	$25 \cdot 10^2$	$22 \cdot 10^2$
Water vapour pumping capacity	g/h	120	130	260	280	330	370	340	340
Inlet and exhaust end fittings	ISO-KF	DN 25 ISO KF							

## Corrosive applications: C1 Series

### Single-stage pumps

Characteristics	Unit	1005 C1		1010 C1		1015 C1		1021 C1	
Frequency	Hz	50	60	50	60	50	60	50	60
Number of stages									
Rotation speed	rpm	1500	1800	1500	1800	1500	1800	1500	1800
Nominal flow rate	m <sup>3</sup> /h	<b>5.4</b>	<b>6.5</b>	<b>9.7</b>	<b>11.6</b>	<b>15</b>	<b>18</b>	<b>20.7</b>	<b>24.8</b>
	cfm		3.8		6.8		10.6		14.6
Flow rate Pneurop method	m <sup>3</sup> /h	<b>4.8</b>	<b>5.5</b>	<b>8.5</b>	<b>10</b>	<b>12.5</b>	<b>15</b>	<b>16.5</b>	<b>20</b>
	cfm		3.2		5.8		8.8		11.8
Ultimate pressure* with gas ballast closed	Torr/mbar /Pa	$3.75 \cdot 10^{-2} / 5 \cdot 10^{-2}$							
Ultimate pressure* with gas ballast open	Torr/mbar /Pa	$3 / 4$ $4 \cdot 10^2$				$5.25 / 7$ $7 \cdot 10^2$			
Oil capacity	l	1.1		1.0		1.0		1.0	
Weight (pump + motor)**	kg (lbs)	21 (46)		22 (48)		24.5 (54)		25 (55)	
Maximum water vapour pumping capacity (Ballast flowrate 1.1 m <sup>3</sup> /h)	mbar	<b>30</b>	<b>25</b>	<b>40</b>	<b>35</b>	<b>35</b>	<b>30</b>	<b>25</b>	<b>22</b>
	Pa	$3 \cdot 10^3$	$25 \cdot 10^2$	$4 \cdot 10^3$	$35 \cdot 10^2$	$35 \cdot 10^2$	$3 \cdot 10^3$	$25 \cdot 10^2$	$22 \cdot 10^2$
Water vapour pumping capacity	g/h	120	130	260	280	330	370	340	340
Inlet and exhaust end fittings	ISO-KF	DN 25							

\* Pressure measured according to Pneurop 6602 specifications with Alcatel 120 oil charge. It may vary if other oils are used (See page 67).

\*\* These values are for pumps equipped with universal single-phase motors.

Note: The pressure measurements were made with a capacitive diaphragm pressure gauge measuring a total pressure in the absence of a cold trap. Measurements using a Pirani type gauge can give different pressure values.

# Pump dimensions

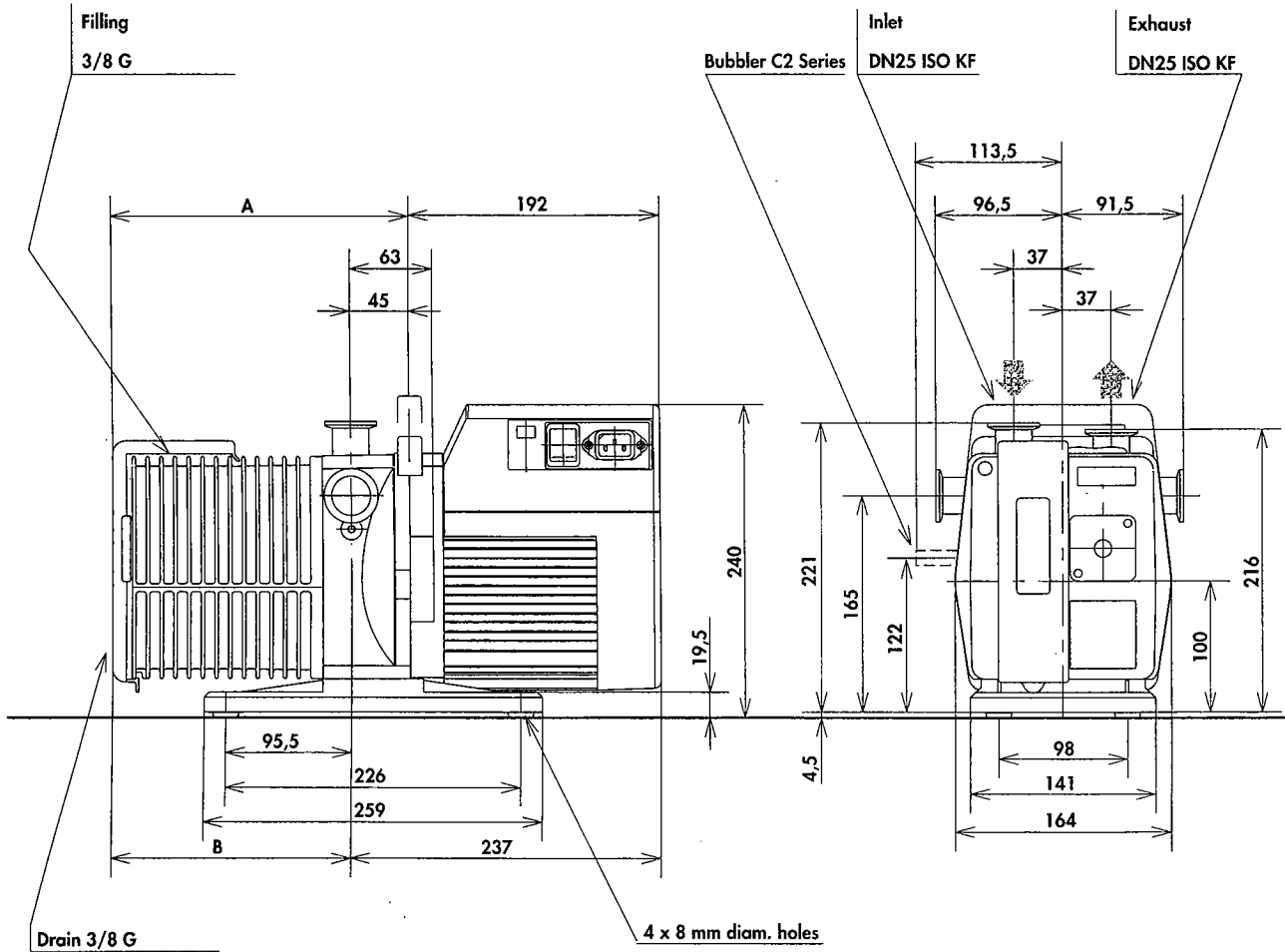

Dim.	Pump type							
	1005	1010	2005	1015	2010	1021	2015	2021
inch/(mm)								
A	9 (229)			9.8 (249)		10.6 (270)		11.5 (291)
B	7 (183)			8 (204)		8.9 (225)		9.7 (246)
C	4.55 (115.5)	5.4 (136.5)	4.55 (115.5)	6.2 (157.5)	5.4 (136.5)	7.03 (178.5)	6.2 (157.5)	7.03 (178.5)

## Accessories

NAME	PART NUMBER	LOCATION	FUNCTIONS
Oil mist eliminator OME 25 S/OME 25 CH	OME 25 S 104200 OME 25 CH 066849	Exhaust	<ul style="list-style-type: none"> <li>Separates oil droplets and particles contained in exhaust gases emitted by the pump.</li> </ul>
High pressure oil mist eliminator OME 25 HP	104199	Exhaust	<ul style="list-style-type: none"> <li>Separates oil droplets and particles contained in exhaust gases emitted by the pump. For high pressure pumping and/or frequent cycles. Can be fitted to the ODK 1 and ODK 2 kits.</li> </ul>
Oil draining kit ODK 1	104360	Gas ballast	<ul style="list-style-type: none"> <li>Connected to the OME25HP, it is used to recover oil via the gas ballast. Note: the pump is not sealed when switched off.</li> </ul>
Oil draining kit ODK 2 ★	104361 230V 50/60Hz 104362 115V 60Hz	Gas ballast	<ul style="list-style-type: none"> <li>Connected to the OME25HP, it is used to recover oil via the gas ballast. Equipped with an electro-valve which seals the pump when switched off.</li> </ul>
Condensate trap CT 25	104201	Inlet or exhaust	<ul style="list-style-type: none"> <li>Prevents liquids and solids contained in the pumped gases from entering the pump, or traps condensable vapors at the exhaust.</li> </ul>
Dust filter DFT 25	104202	Inlet	<ul style="list-style-type: none"> <li>Prevents dust particles larger than 6 microns from entering the pump.</li> </ul>
Liquid nitrogen trap LNT 25 S or LNT 25 C	Aluminum 104197 St. steel 066889	Inlet	<ul style="list-style-type: none"> <li>Protects the pump against condensable vapours.</li> <li>Prevents oil from backstreaming into pumped chamber.</li> </ul>
Sorption trap ST 25 S or ST 25 C	Aluminum 104107 St. steel 066841	Inlet	<ul style="list-style-type: none"> <li>Prevents oil backstreaming when pumping in a "clean" vacuum.</li> </ul>
Automatic gas ballast AGB 4 ★	104086 230V 50/60Hz 104087 115V 60Hz	Gas ballast	<ul style="list-style-type: none"> <li>Remote control for gas ballast.</li> <li>Allows the gas ballast to be closed when the pump is off, ensuring that the pump is tight.</li> </ul>
Isolating safety valve ISV 25 ★	066832 220V 50Hz	Inlet	<ul style="list-style-type: none"> <li>In the event of a power failure, it isolates the vacuum chamber from the pumping unit and ensures chamber venting.</li> </ul>
Oil filter DE	066890 220V 50/60Hz 104373 115V 50/60Hz	External device	<ul style="list-style-type: none"> <li>Filters and/or neutralizes oil when pumping gases which are corrosive and could rapidly degrade oil quality.</li> </ul>
Shock mount	082691 LAX 100 model D	Between base and machine frame	<ul style="list-style-type: none"> <li>Helps isolate pump vibration.</li> <li>Allows pump to be mounted on a frame.</li> </ul>

### Précautions

★ Other voltages and frequencies available in the Alcatel catalog

 In general, use accessories in which the tightness and materials are compatible with the pumped gases and the required safety conditions at both the inlet and the exhaust.

At the pump exhaust, the discharge circuit must be such that the resulting excess pressure in the oil case is as low as possible.

**The maximum excess pressure recommended for correct pump operation is 0.5 bar (6 PSI).**

A slight negative pressure in the oil case (0.1 to 0.2 bar / 1.5 PSI), at the exhaust, will prevent gases from accumulating and reduce pump corrosion and pollution.

 If the exhaust orifice is connected to an extraction duct or an oil mist eliminator, **you must remove the exhaust safety valve mounted in the pump's exhaust orifice.**





# Safety instructions concerning the installation and operation of pumping systems



Before switching on the equipment, the user must read all of the start-up and operation sections of this manual and observe the safety instructions listed in the booklet of declarations of compliance supplied with the unit.

## Unpacking

When you receive the equipment, unpack it carefully. Do not discard the packaging until you have ensured that the pump has not been damaged during transport. Otherwise, take the necessary measures with the transporting company and, if necessary, notify ALCATEL.

For all handling, only use the devices provided for this purpose (lifting rings, handle, etc.).

**The pump is not supplied filled with oil. The oil is contained in separate bottles. Similarly, it is recommended to drain the pump before redispaching the equipment.**

## Storage

- If the pump is to be stored, we guarantee the reliability of our equipment without particular storage precautions for up to 3 months (ambient temperature between 41°F and 149°F or 5 and 65°C).
- For storage periods of over 3 months, we recommend to fill the pump with oil during storage. For this, fill the pump and run it at ultimate vacuum (inlet orifice blocked) for approximately 1 hour in order to lubricate all the parts of the functional block (*see page 76*).  
Then, stop the pump and store it with the inlet and exhaust orifices sealed: clamping ring, centring ring, plug, etc.  
The shaft should be rotated by hand or by starting the pump every six months following this storage procedure.
- After 6 months storage without oil, factors such as temperature, degree of humidity, salt air, etc. may cause the deterioration of the pump components, particularly the hardening of O-rings and the "sticking" of lip seals on shafts and the gumming of oil. In this state, a pump may have operational problems, particularly oil leaks. Before any start-up (new pump as well as used), the pump must be disassembled (*see page 91*), and all the seals changed.

### Note 1:

The seal kits must be stored with caution. Keep them away from heat and light (sunlight and ultraviolet light) in order to prevent the elastomers from hardening (AFNOR standard FD T 46.022).

## **Installation and start-up**

- The machines must be connected to an electrical installation in compliance with decree 88-1056 dated 14th November 1988, as well as any local electrical codes that apply.
- It is important to isolate the machine from the power source before any intervention on the equipment (for maintenance purposes).
- When switching off the power of equipment containing capacitors loaded with over 60 VDC or 25 VAC, take precautions when accessing the connector pins (single-phase motors, equipment with mains filter, frequency converter, monitor, etc.).
- Vane roughing pumps use lubricants, it is recommended to request information from the manufacturer on the safety data sheets concerning the product used.
- Our pumps are tested in the factory with ALCATEL 120 oil or Alcatel 119 for the USA (Alcatel 113 oil for the C2 series). It is recommended to use the same oil during operation.  
If changing the type of oil, refer to the chapter concerned for the procedure and the type of lubricant required.
- Our pumps are designed to prevent any thermal risk for user safety. However, specific operating conditions may generate temperatures which may justify particular attention on the part of the user (outer surfaces > 70°C).

### Assembly (continued)

- we do not recommend an oil mist eliminator when pumping condensable vapors: if it is essential, do not connect it directly to the pump exhaust but place it outside the condensation zone.
- remove the stop valve from the pump exhaust;
- if possible, connect the exhaust to a mechanical device creating a negative pressure from 0.1 to 0.2 bar.

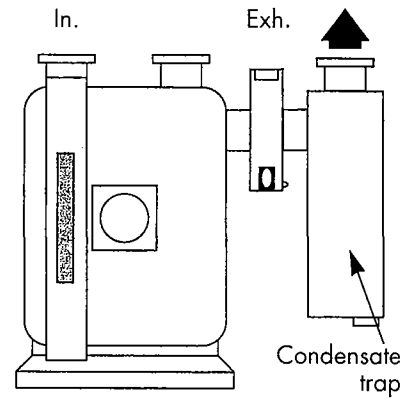

### Vapor pumping procedure

- Valve off the pump from the system and increase the pump temperature, 30 minutes with gas ballast (*see page 76*).
- Start pumping and check the oil level:
  - the level drops, oil is being lost;
  - the level rises, condensates have been added to the oil.
- After pumping, regenerate the oil using gas ballast if it is cloudy or discoloured.
  - if the level is too high, change the oil and regenerate.
- Change the oil as soon as inlet pressure characteristics drop and are not improved by regeneration.

# Operation of gas ballast

## Regeneration of pump oil

In a pump stored with the same oil for a long time, condensed vapours may contaminate the oil bath and affect performance. This is also the case after pumping vapours and when the oil appears cloudy or discolored through the sight glass.

- Run the pump, shutting it off from the system at the inlet by a valve or a plug.
- Open the gas ballast and allow the pump to operate for 1/2 hour to 1 hour, or longer if the oil remains cloudy. This operation accelerates the temperature rise of the pump while eliminating residual vapours present in the oil bath.

## Pumping condensable vapours

To pump with condensable products, it is necessary to operate with a hot pump. For this, isolate the pump from the system and allow it to operate for 1/2 hour with the gas ballast open, or 1 hour (if possible) with the gas ballast closed. When the oil bath is hot, the condensation of vapours in the pump is reduced or prevented.

## Choice of pump and system

The pump's capacity to eliminate condensable vapours is related to their type, the pump temperature and the quantity of air introduced by the gas ballast. Thus, for high vapour levels in a system, the single-stage pump is more suitable. However, when not pumping vapours, its ultimate pressure is higher. Care should be taken to limit the inlet pressure of the pump to its maximum admissible water vapor pressure with the pumped product. This is obtained by reading the pump characteristic table for water vapour. The use of cold traps or condensers are recommended when large quantities of vapours are to be extracted. Excessively intense or prolonged pumping may cause the products condensed in the trap to be evaporated a second time.

## Choice of oil

Choose an oil which facilitates the separation of pumped products which may be condensed in the oil bath (anti-emulsion oil for water-based compounds, etc.) (*see page 67*).

## Assembly

The condensation of vapours at the pump exhaust is reduced if:

- the pump and oil temperature are high;
- the pressure at the exhaust is as low as possible (removal of the oil mist eliminator...);
- the condensates are collected separately from the oil bath and do not block the exhaust duct.

For this:

- avoid using any vertical ducting which promotes the condensation of products and the return of these products to the pump.
- use a condensate collector;

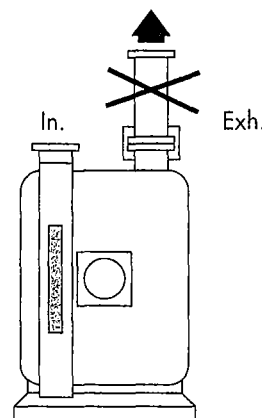

Operation

## **Start-up**

- When using a three phase motor, **check the direction of rotation of the motor** (see electrical connections *start-up chap. page 71*).
- **Check the oil level** (*See page 68*).
- **Start-up the pump.**
- **Allow the pump to run for one hour with the inlet blocked at ultimate vacuum:**

During this operation, make sure that the oil circuit is operating. Remove one of the oil fill plugs to listen to the pump.

At start-up, the oil enters the lubrication circuit of the vacuum pump. As a result, noises will be heard (first irregularly, then regularly) which will reduce as the oil heats up. These noises will no longer be heard when the fill plug has been replaced.

Under normal temperature conditions, the oil circuit should start less than 1 minute after start-up (this time may vary with the type of oil and its degree of contamination).

- **Using the gas ballast:**

- to decontaminate the pump's oil;
- to accelerate heating. It is normal for the oil level to change (as can be seen through the oil sight glass) when the pump is hot, due to expansion of the oil, starting of the oil circuit and the operating conditions of the pump (inlet pressure). If necessary, stop the pump and adjust the oil level between the "max" and "min" levels on the sight glass.

In the event of a malfunction, refer to the "Troubleshooting and corrective actions" table (*page 84*).

# Operation

## Preliminary precautions



- The performance and operating safety of this product can only be guaranteed if it is operated according to normal conditions of use.
- The vacuum pump is also a compressor: incorrect operation may be dangerous. Study the user manual before starting up the pump.
- The pumps are designed to prevent any thermal risk for user safety. However, specific operating conditions may generate temperatures which may justify particular attention on the part of the user > 70°C).
- Product tightness is guaranteed for normal operating conditions when the product leaves the factory. It is the user's responsibility to maintain the level of tightness particularly when pumping dangerous products (on C series pumps).

Be sure to fill the pump with oil (see page 68).

## Operating temperature

- At start-up, before switching on the motor, check that the oil bath temperature is greater than 53°F (12°C).
- The ambient operating temperature for the pump must be between 53°F (12°C) and 113°F (45°C).
- Under these conditions, the stabilized pump temperature (at the front of the oil case) will be between 140°F and 158°F (60 and 70°C) (depending on operating conditions).

### Special case - Synthetic oils

Synthetic oils are much more viscous when cold than mineral oils. Do not start up the pump at ambient temperatures below 59°F (15°C). For the same reason and to facilitate lubrication of the pump, pour a few drops of oil (1 to 2 cm<sup>3</sup>) through the inlet orifice before starting.

## Before starting-up the pump



Check that the exhaust orifice is not blocked.

In certain cases, when the pump is started up in cold ambient conditions, or with slightly contaminated oil, the current after start-up may remain high until the oil in the pump is heated up. These conditions are sufficient for the internal thermal protection to be activated, making start-up impossible (see pages 72 & 73).

## Incidents

## Causes

## Corrective actions

Incidents	Causes	Corrective actions
The vacuum pump does not produce a vacuum (continued)	<b>Ultimate pressure obtained: a few <math>10^{-2}</math> Torr (<math>10^{-2}</math> mbar)</b>	
	• Gas ballast adjustment button open.	Close.
	• O-ring pinched.	Replace.
	• One of the seals is damaged.	Replace.
	• One of the HP. safety valves is damaged.	Replace.
	• Lubrication holes blocked.	Disassemble and clean.
	• Incorrect anti-suckback assembly.	Repeat the assembly and setting.
	• Part forgotten in reassembly.	Repeat the reassembly.
	<b>Accessories</b>	
	• At the pump exhaust, the installation produces an exhaust pressure of 1,125 Torr (1.5 bar).	Check the installation.
	• Oil mist eliminator cartridge clogged.	Replace.
Noisy pump	• Oil level too high.	Drain and fill with a new oil.
	• Oil contaminated (presence of particles).	Drain, flush and refill with clean oil.
	• Pump not prepared for the oil used.	Check the pump configuration or the type of oil.
	• Incorrect motor power supply.	Check the power supply.
	• Motor bearings damaged.	Replace the motor after inspection.
	• Motor coupling incorrectly set or damaged.	Check the setting.
	• Incorrect fan assembly.	Check the assembly.
	• Incorrect anti-suckback device assembly	Repeat the assembly.
• Vanes damaged or stuck.	Replace.	
Pump too hot	• Ambient temperature too high.	
	• Pump placed in a poorly ventilated place or vents blocked.	Check the installation.
	• Operation at high pressure $P > 22$ Torr (30 mbar).	Check for system leaks.
	• Excess pressure at exhaust.	Check the exhaust line.
	• Motor in over-voltage or Motor in short-circuit.	Check the voltage, replace the motor.
	• Oil contaminated.	Drain, flush and refill with clean oil.
	• Pump not prepared for the oil used or oil unsuitable.	Check pump configuration or type of oil.

## Incidents

## Causes

## Corrective actions

Incidents	Causes	Corrective actions
<b>Considerable oil losses.</b>	• Oil level too high.	Drain and fill with new oil.
	• Operation at high pressure.	Use an HP type oil mist eliminator with oil recovery.
	• Gas ballast open: 1 - accidentally, 2 - pumping of condensable vapours.	1 - Close. 2 - Use a condensate collector.
	• Leak at oil case seal or at front seal.	Check the assembly and replace the seals if necessary.
<b>Poor pump tightness when switched off.</b>	• Gas ballast open.	Close.
	• Safety valve damaged.	Replace.
	• Incorrect anti-suckback assembly.	Repeat the assembly.
	• O-ring pinched.	Replace.
	• Seals damaged.	Replace.
	• Oil contaminated.	Drain, flush and refill with clean oil.
<b>Oil in base.</b>	• Oil case and frame cleaned poorly during reassembly.	Remove the base and clean.
	• Oil case seal pinched.	Disassemble the oil case, clean the faces and refit a new seal.
	• Front seal damaged or felt saturated.	Replace.



# Maintenance

## Maintenance frequency

An incorrect ultimate vacuum or a reduction in pumping speed are signs that the oil has deteriorated.

The periodic inspection of the state of the oil is performed by comparison with a sample of new oil in order to check the level of contamination or deterioration of the lubricant.

The frequency at which oil is renewed is adapted to the type of operation:

- if the oil is cloudy, this indicates that condensables have been absorbed during pumping. The oil can be regenerated using the gas ballast (*see page 77*).
- a thickening of the oil, together with a blackish color and a "burnt" smell indicate that the oil has deteriorated.

Drain the pump and flush it.

Normally, **for a pump operating continuously at a pressure lower than 0.75 Torr (1 mbar) with a clean gas (dry air), the oil should be changed every 6 months.**

**This value is given as a guide only.** It may be extended to 1 year if the ultimate vacuum required is sufficient (for primary vacuum pumps).

Similarly, **if the pump is stopped frequently for long periods, the oil should be changed at intervals of 6 months to a maximum of 1 year** (oil may become sticky).

**Note:** Every pumping operation is different. This oil must therefore be changed at intervals adapted to each specific application. The use of certain accessories (*see page 63*) can reduce the frequency of these maintenance operations.

## Draining



The draining operation places the contaminated pumping circuit in communication with the outside atmosphere. Take all necessary steps to ensure personal safety.

The pump must be drained when hot and after the oil case has been vented to atmospheric pressure. For this:

- switch off the pump;
- isolate the pump or disconnect from the installation;
- tilt the pump;
- unscrew the draining plug on the side of the oil case and the filling plug on the top of the oil case.

When all the oil has drained, replace the two plugs temporarily and run the pump for about 10 seconds leaving the intake open. Take care with the oil mist which may appear at the exhaust. This operation removes the oil from the functional block;

- drain this oil by removing the draining plug;
- replace the draining plug and fill with fresh oil to the appropriate maximum level of the oil case oil sight glass through the filling orifice (*see page 69*).

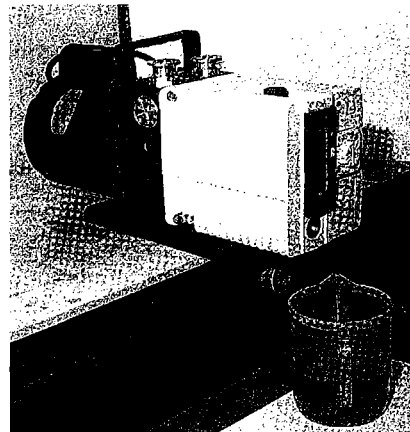

## Flushing

The draining operation can be followed by a flushing operation if the oil is particularly dirty. This operation requires a volume of oil equal to the capacity of the pump.

After draining the oil case (**see page 87**), replace the draining plug. Remove the intake filter, clean it and replace it. Run the pump at atmospheric pressure, pour the flushing oil **very slowly** through the inlet orifice. Take care with oil mist which may develop at the exhaust. Stop the pump and drain the flushing oil via the draining plug. Replace the plug and fill with fresh oil (**see page 68**).

## Change of type of oil

ALCATEL 5 to 21 m<sup>3</sup>/h series pumps are tested in the factory with ALCATEL 120 oil or Alcatel 119 for USA (ALCATEL 113 for C2 series pumps) unless specified otherwise in the order. When the pump is delivered, a certain quantity of oil remains in the functional block

Thus, if you wish to use another type of oil, proceed as follows:

### Compatible oils

Mineral oil can be replaced by another type of mineral oil. Simply flush the pump (**see above**) using the new oil and fill the pump (**see page 68**).

Mineral oils are also compatible with mineral-based synthetic oils (**see page 67**).

### Incompatible oils

This is the case when, for example, a mineral oil is replaced by a synthetic oil (e.g. ALCATEL 120 by ALCATEL 113).

Synthetic oils are considered to be incompatible with each other for practical reasons: they are expensive. A mixture may cause slight cloudiness of the resulting mixture, which could be interpreted mistakenly as a sign of contamination or deterioration.

For the same reasons, clear synthetic and mineral oils (ALCATEL 300), which are also expensive, are treated as synthetic oils.

These remarks apply to ester or fluorocarbon type synthetic oils and the oils Alcatel 111, 113 and 300 (**see page 67**).

Proceed as follows:

- Disassemble the pump completely and clean it (**see page 91**).
- Reassemble it.
- Connect an oil mist eliminator to the pump exhaust.
- Fill the pump with the new oil (**see page 68**).

NOTE: to replace a synthetic oil by a mineral oil, proceed as for compatible oils.

## Replacement of front seal

In the event of an external oil leak on the pump, it is necessary to change the shaft seal on the motor side.

You will need:

- a front seal replacement kit  
(see page 90),

- a screwdriver,

- a 3, 4 and 5 mm Allen wrench.

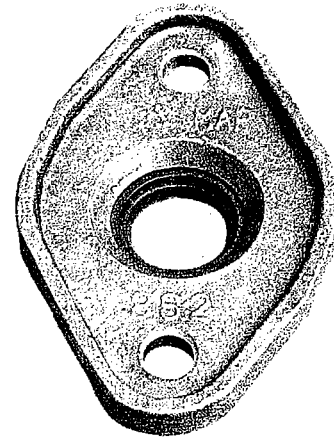

- Stop the pump and disconnect the power cord motor.
- Disconnect the pump from the installation to which it is connected.
- If possible, position the pump vertically, with the motor at the top, resting on the front side of the oil case; in this position, it is not necessary to drain the oil case. Otherwise, disassemble the pump in the horizontal position, resting it on its base, after it has been drained.
- Disconnect the motor by unscrewing the 4 fastening screws, simultaneously and alternately.
- Remove the motor vertically.
- Unscrew the fan fastening screw. Remove the fan, the key and the support washer.
- With a screwdriver, remove the shaft sleeve and its O-ring.
- Unscrew the two seal-holder fastening screws and remove the seal-holder.
- Remove the seal from the seal-holder as described on page 95 and discard it.
- Clean the metal parts. Inspect the wearing side of the shaft sleeve: after cleaning, the sleeve may show a perfectly normal trace of rubbing (caused by polishing). Should the sleeve show any signs of indentation or grooves, it must be replaced.
- Preferably use new parts from the seal kit or set of seals.
- Reassemble the lip seal in its housing as described on page 95.
- Reinsert the new O-ring on the seal-holder.
- Insert the shaft sleeve inside the seal-holder.
- Engage the reassembled seal-holder on its axis and screw onto the frame.
- Insert the O-ring in the shaft sleeve. Position the support washer. Then, install the key, reassemble the fan and the motor in the reverse order of disassembly.
- Immediately order a replacement maintenance set or kit (see page 90).

## Tools and consumable products

### Special precautions

- Read the warning at the beginning of the maintenance chapter.
- Before disassembling the pump, drain it (see page 87).
- All the seals and faulty parts should be replaced, provide for a seal kit or a maintenance kit.

### Spare parts

#### Minor kit

This contains all the seals on the pump which must be replaced at each complete disassembly.

Pump models	Part No.
SD	103911
I / C1 / C2	103912

Keep this kit in a dry place, away from heat and light (sunlight and ultraviolet light), in order to prevent any hardening of the elastomers (see AFNOR standards: "storage conditions for vulcanized elastomer based products" - FD T.46 022).

#### Major kit

In addition to the seal kit, this kit contains a set of spare parts to perform maintenance operations on the pump for a two year period, under normal operating conditions.

Pump models	Part No.
2010 C2	104614
2015 C2	104615
2021 C2	104616
1005 C1	104617
1010 C1	104618
1015 C1	104619
1021 C1	104620
1005 SD	104622
1010 SD	104623
1015 SD	104643
1021 SD	104644

Pump models	Part No.
2005 SD	103902
2010 SD	103903
2015 SD	103904
2021 SD	103905
2005 I	103906
2010 I	103907
2015 I	103908
2021 I	103909
2005 C1	104976
2010 C1	104977
2015 C1	104978
2021 C1	104979

**Front seal replacement kit**  
(parts for shaft passage tightness on motor side)

This kit contains all the parts which must be replaced in the event of a leak on the shaft on the motor side.

Pump models	Part No.
SD	065875
I / C1 / C2	065612

#### Screw kit

This kit contains all screws and washers for all pump models.





Screw kit	Part No.
All pumps	104919

#### Specific tools

Lip seal assembly mandrel.

Pump models	Part No.
All models	052993

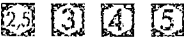
### Recommended tools

- Two 5.5 x 100 flat screwdrivers 
- Thin spanner: 10 mm on face 
- Allen wrenches: 2.5 - 3 - 4 - 5 mm 
- 12 mm box wrench 

## Disassembling the pump

### Disassembling the motor block

**3** Remove the motor cover.

**5** Remove the motor attachment screws.

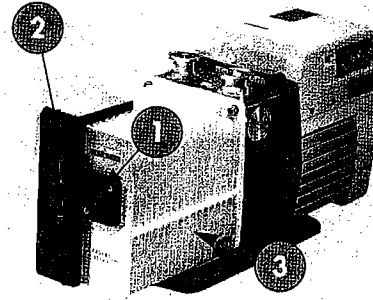

### Disassembling the fan

**4** Remove the fan fastening screw and the support washer. Remove the key.

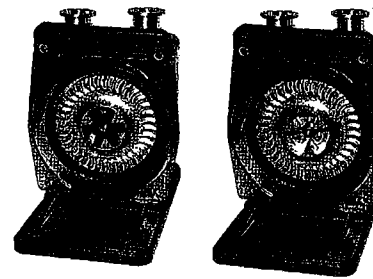

### Replacing the front seal

See page 89.

### Disassembling the gas ballast (1)

**2,3** Remove the gas ballast cover (2 screws), the adjustment button, the spring and the sleeve. Remove the tank feed-through (2 screws) and its seal.



### Disassembling the oil sight glass (2)

**3** Remove the sight glass cover. Remove the plate, the sight glass and the O-ring.

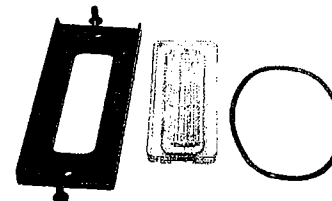

### Removing the oil case (3)

**5** Remove the oil case and its O-ring after removing the 4 fastening screws.

### Disassembling the bubbler (C2 pump)

**1** Disconnect the nitrogen inlet. Remove the nitrogen inlet and disconnect the connector (**4**). Disconnect the nut which secures the tube on the functional block and pull the tube (**5**) to release it from the frame.

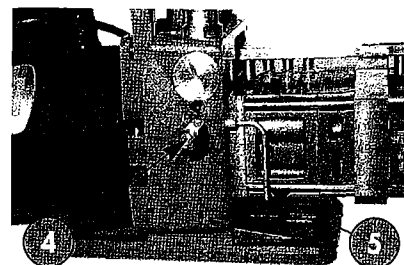

**Disassembling the exhaust valve cover (6)**

**5** Remove the cover(s), the exhaust valves and their springs.

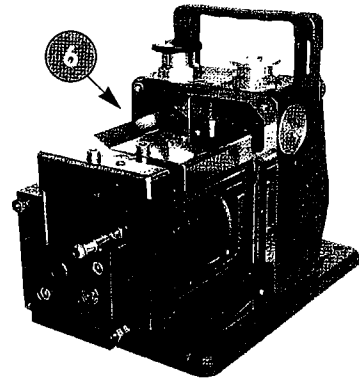

**Disassembling the SD pump oil system (except 1015 SD, 1021 SD)**

The oil system is set in the factory, it must be reset in the event of disassembly (see reassembly). However, the rear flange (7) can be disassembled without modifying the setting. Remove the spinner-cam (8) by removing the circlip. Do not disassemble the nozzle to clean it. During the reassembly, check that it is not blocked by sending a jet of compressed air through it.

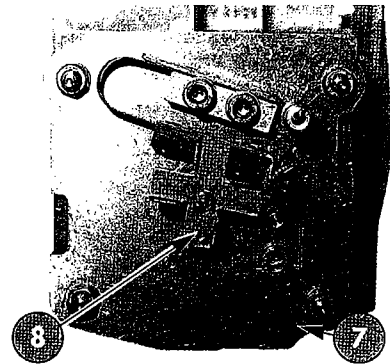

**Disassembling the I, C1, C2 pump oil system also 1015 SD, 1021 SD**

**5** Remove the cover from the oil pump (9). Release the cylinder (15) equipped with the washer, piston and spring. Release the stop valve (10) from its housing.

**12** Unscrew the seat of the stop valve (11) and remove the O-ring. Then remove the vane (12), the oil pump rotor (13) and the Oldham coupling (14).

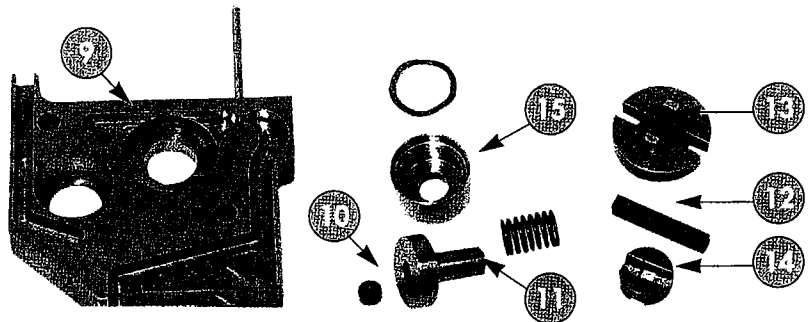
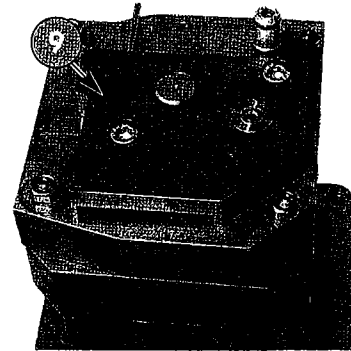

### Disassembling the rear flange

10 Remove the 4 nuts (and washers). Release the flange in the axis.

### Disassembling the HP stator and the rotor (two-stage pumps)

Remove the stator by sliding it along the rotor.

Release the rotor and the vanes.

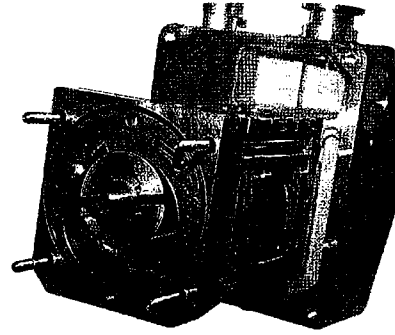

### Disassembling the intermediate flange (two-stage pumps)

Insert two screwdrivers in the notches and release the flange in the axis.

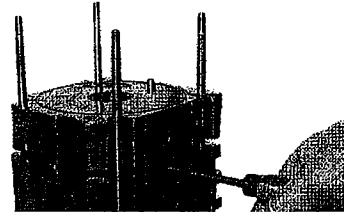

### Disassembling the LP stator and the rotor

Remove the LP stator.  
Remove the rotor and the vanes equipped with the springs.

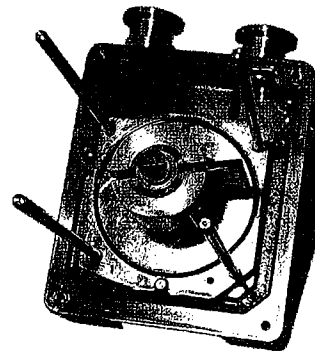
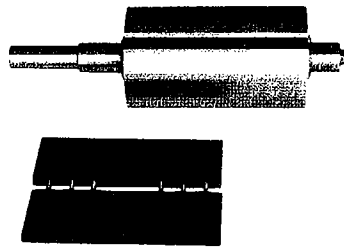

# Cleaning components

## Cleaning metal components

Solvents are required to clean components.

Standard precautions should be taken in compliance with the manufacturer's instructions.

**After use in mineral or synthetic oil**, clean the metal components with a mineral products based solvent such as **AXAREL**<sup>(1)</sup>, **CARECLEAN**<sup>(2)</sup>, **PREMACLEAN**<sup>(3)</sup>, **NAPHTEOL**<sup>(4)</sup>. Proceed as follows:

- Clean when cold or hot (max. 45°C) by dipping or using a cloth
- Vacuum dry in a ventilated oven
- **The component must be cleaned a second time with alcohol.**

**After use in (perfluorinate) synthetic oil**, clean the metal components in a solvent such as **GALDEN S 90**<sup>(5)</sup> and proceed as follows:

- Clean when cold by dipping or using a cloth
- Dry the components in the air or with compressed air

**After use in (non-perfluorinate) synthetic or mineral oil**, clean the metal components with a solvent such as alcohol and proceed as follows:

- Clean when cold by dipping or using a cloth
- Dry the components in the air
- Industrial washing solutions can also be used. The cleaning operation should be followed by vacuum drying.

## Cleaning the oil level sight glass

### I, SD, C2 series pumps

When cleaning this plastic sight glass, avoid contact with alcohol or alcohol-based washing solutions. Clean the component with a solvent, but do not steep it, and rinse it immediately.

### C1 series pumps

The sight glass of these pumps is made of glass.

(1) DUPONT DE NEMOURS registered trademark  
(2) CASTROL registered trademark  
(3) DOW registered trademark  
(4) Nippon Chemical registered trademark  
(5) MONTEDISON registered trademark



# Replacement of shaft seals

- Specific tools**
- Specific assembly mandrel.
  - A support plate (or washer).

- Recommended tools**
- A flat screwdriver 

## Extracting a shaft seal from its housing

With the flange flat, the seal is extracted using a screwdriver, resting on the plate (or washer) so as not to damage the seal housing.

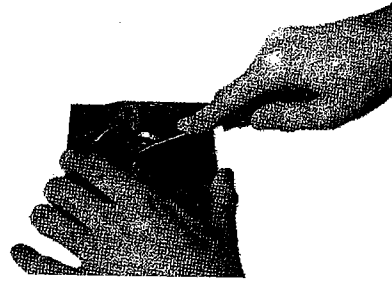

## Assembling the shaft seal

The seal housing and the seal lip are lubricated with the lubricant used in the pump. The flange is resting on a flat surface.

According to the direction of assembly specific to each pump, the seal is fitted on the assembly mandrel.

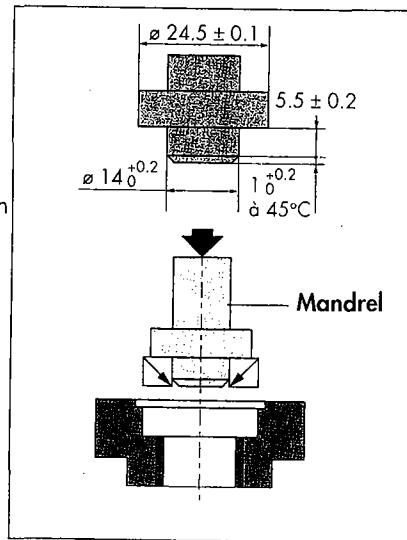

Using a press or a hammer, the seal is inserted in its housing.

## Direction of assembly of shaft seals

They are fitted using the assembly mandrel according to the direction of assembly below:

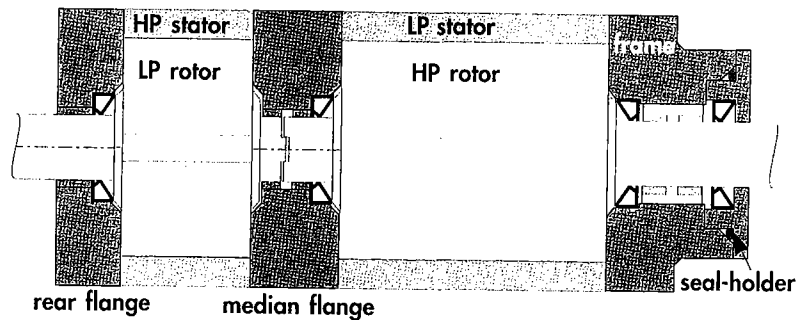

# Reassembling the pump

## Component preparation

- Rest the frame on a flat surface in order to raise the pump.
- All surfaces in contact are coated with oil.
- Observe a **nominal clamping torque of 0.8 mdaN (5.8 ftlbs) for the reassembly of the functional block.**

The functional block is reassembled in the reverse order of disassembly.

## Reassembling the median flange

On the median flange, check that the lubrication hole is not blocked.

New vanes are assembled on **the rotors**, with the rounded edges facing outwards.



## Reassembling the exhaust valve cover

Pour a small quantity of oil beforehand around the exhaust valve holes. Position the exhaust valves, the springs and the exhaust valve covers.

## Reassembling the bubble device - C2 series pump

This is performed after the reassembly of the functional block, before fastening the nuts. Fit a new seal on the tube and connect the assembly to the frame. Position the tube attachment on the pin and tighten the nut on the rear flange (maximum clamping torque 0.8 mdaN (5.8 ft lbs)). In the sleeve, fit the ball and the spring and fasten the connector. Then fasten the assembly on the side of the frame.

## Setting the oil system

**SD series pump (except 1015 SD, 1021 SD):**

Offset the spinner-cam (1) by pressing on the blades.

Turn the shaft up to the maximum displacement of the lever (2).

The distance between the seat (3) and the stop valve (4) must be 0.9 to 1.2mm (0.035 to 0.047 inch) :

it is set by adjusting the orientation of the lever.

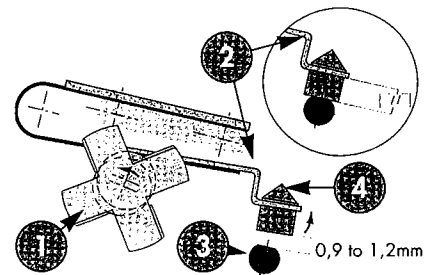

The stop valve face must be perpendicular to the axis of the oil inlet hole; when free, the stop valve should rest on its seat: check the parallelism of the lever in relation to the bearing face of the stop valve seat. Orient the seat to obtain the correct setting.

**I, C1, C2 series pump (also 1015 SD, 1021 SD):**

Position the rotor of the oil pump so that the slot is horizontal (or parallel with the pump base). To turn it, use the fan. Do not forget the Oldham coupling.

## Reassembling the oil case

Fit the oil case on the frame. Fasten the attachments after making sure that the seal is positioned in its seal groove (clamping torque 0.8 mdaN (5.8 ft lbs)).

## Reassembling the gas ballast

Position the oil case feed-through equipped with the seal in its housing by centering it on the gas ballast tube. Assemble using the screws.  
Equip the adjustment knob with the sleeve and the spring. Position the assembly in the cover and secure on the oil case feed-through.

## Reassembling the oil level sight glass

Replace the O-ring (included in the seal kit).  
Fit the sight glass and assemble with screws (clamping torque 0.3 mdaN (2.14 ft lbs)).



**C1 series pump: The sight glass is made of glass: gradually tighten the two attachment screws in alternation to avoid placing the sight glass under stress.**

## Reassembling the seal-holder

See page 89.  
Fit the fan 1/2 sleeve.

## Reassembling the motor side components

Fit the drive key on the motor shaft.  
Install the motor coupling sleeve down to the stop on the motor shaft.  
Fit the motor on the frame and install the 4 mounting bolts (clamping torque 1 mdaN (7.14 ft lbs)).



## Composants de maintenance / Maintenance components / Unterhaltung Teile

Plan de montage cuve et bâti	Oil casing and central housing assembly plan	Gesamtplan Ölbehälter und Pumpenträger . . . . .150 / 152 / 154
Nomenclature cuve et bâti	Oil casing and central housing part list	Nomenklatur (I) Ölbehälter und Pumpenträger . . .151 / 153 / 155
Plan du bloc fonctionnel (C)	Moving part plan (C)	Gesamtplan (C) Pumpenblock . . . . .156 / 158
Nomenclature du bloc fonctionnel	Moving part parts list	Nomenklatur Pumpenblock . . . . .157 / 159
Plan du système de lubrification pompe à huile (A)	Oil pump system plan (A)	Gesamtplan (A) Ölpumpsystem . . . . .160
Nomenclature du système de lubrification pompe à huile (A)	Oil pump system part list (A)	Nomenklatur (A) Ölpumpsystem . . . . .161
Plan du système de lubrification levier moulinet (B)	Oil system plan (B)	Gesamtplan (B) Ölpumpsystem . . . . .162
Nomenclature du système de lubrification levier moulinet (B)	Oil system part list (B)	Nomenklatur (B) Ölpumpsystem . . . . .163
Plan ensemble motorisation (M)	Motor assembly plan (M)	Gesamtplan (M) Motor . . . . .164
Nomenclature ensemble motorisation (M)	Motor assembly part list (M)	Nomenklatur (M) Motor . . . . .165
Plan du système bulleur	Bubbler system plan	Gesamtplan Bubbler system . . . . .166
Nomenclature du système bulleur	Bubbler system part list	Nomenklatur Bubbler system . . . . .166

**Plan de montage cuve et bâti**  
**Oil casing and central housing assembly plan**  
**Ölbehälter und Pumpenträger Gesamtplan**

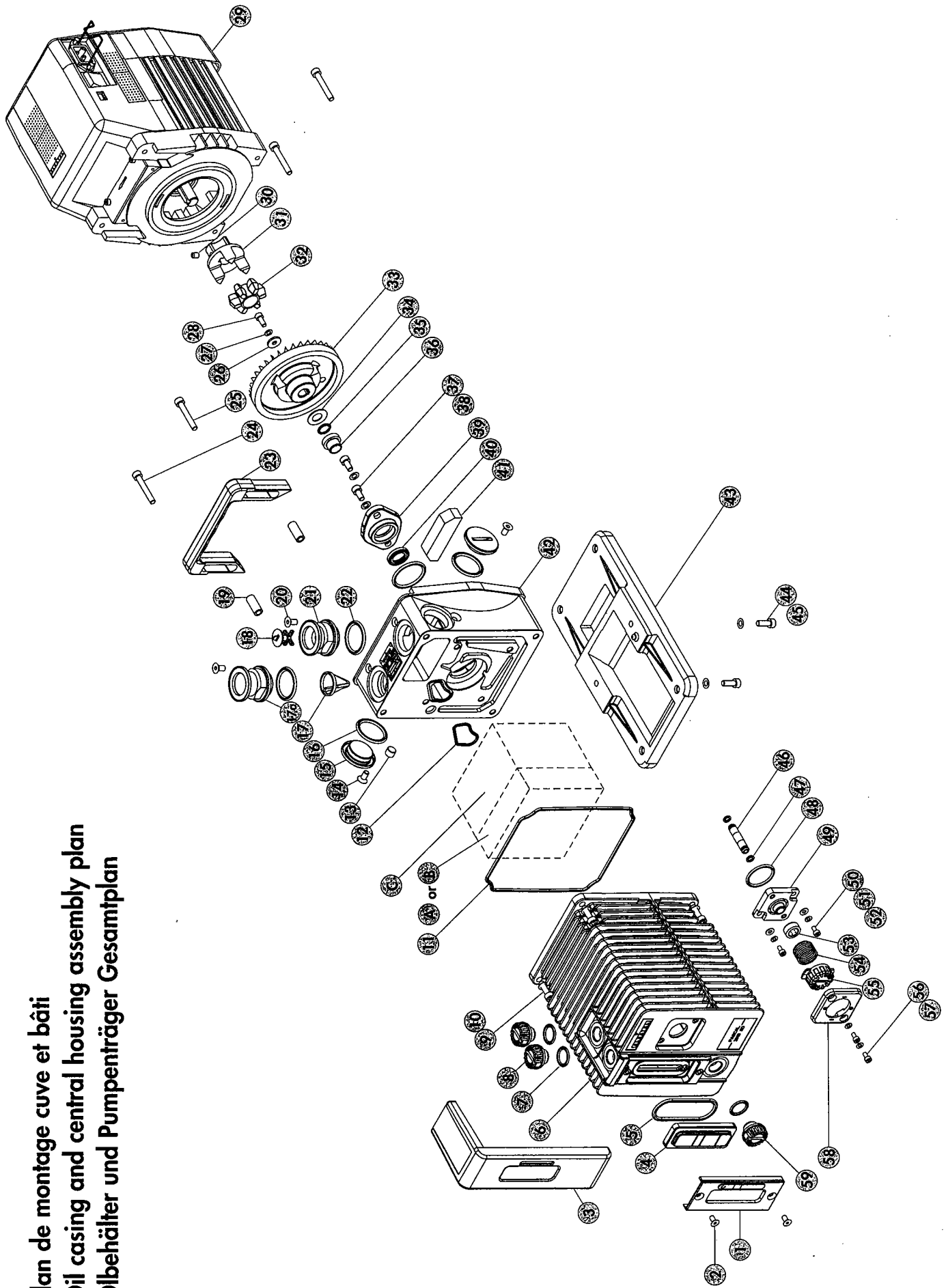



**Plan de montage cuve et bâti**  
**Oil casing and central housing assembly plan**  
**Ölbehälter und Pumpenträger Gesamtplan**

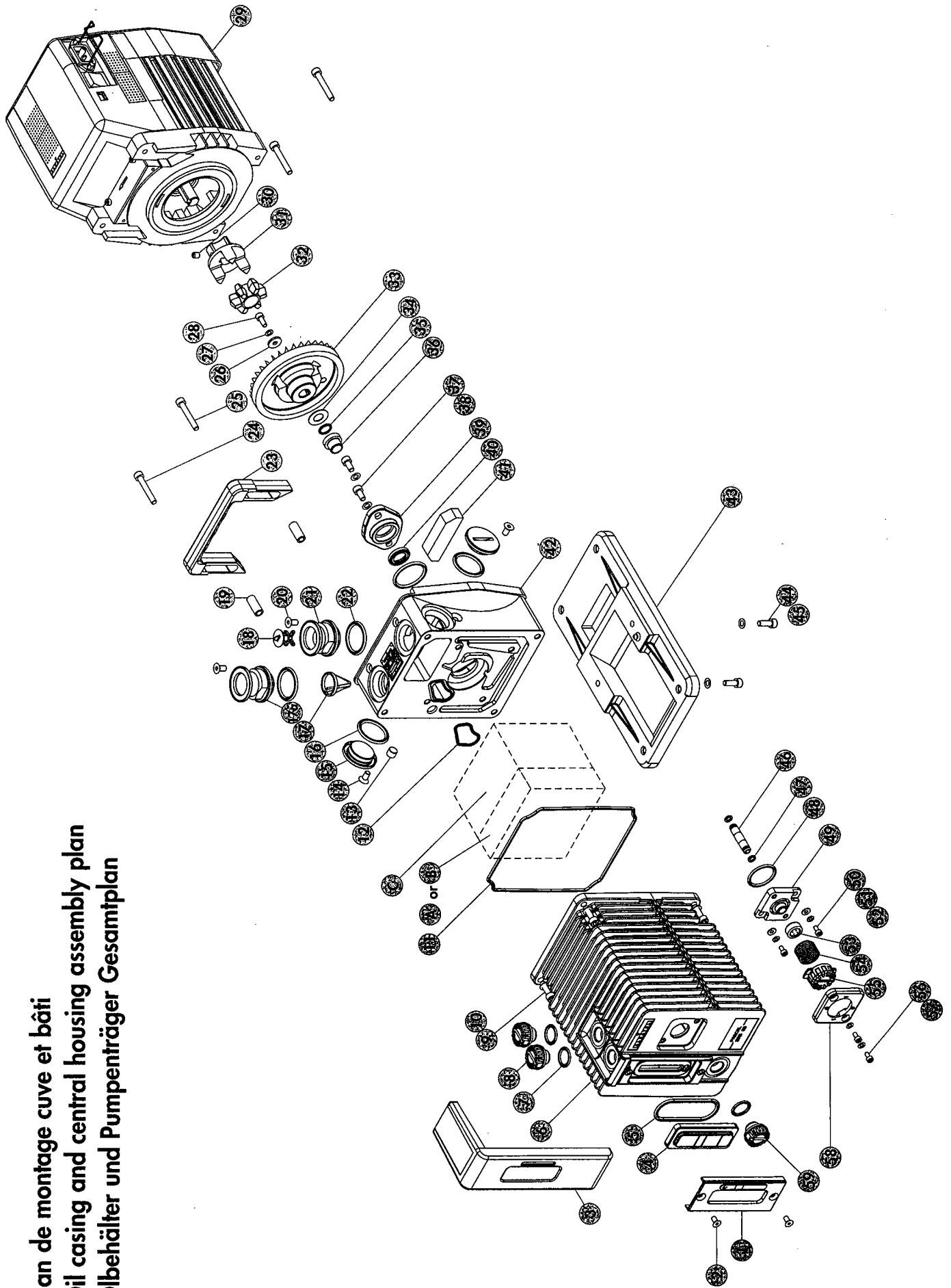



# Nomenclature cuve et bâti / Oil casing and central housing part list / Ölbehälter und Pumpenträger Nomenklatur

				TYPES/MODEL																REF.									
REP	DÉSIGNATION	SPECIFICATION	BENENNUNG	2005 I	2010 I	2015 I	2021 I	2005 SD	2010 SD	2015 SD	2021 SD	1005 SD	1010 SD	1015 SD	1021 SD	2010 C2	2015 C2	2021 C2	2005 C1	2010 C1	2015 C1	2021 C1	1005 C1	1010 C1	1015 C1	1021 C1	P/N Bestell. Nr		
23	Poignée	Handle	Griff	1	1	1	1	1	1	1	1	1	1	1	1	1	1	1	1	1	1	1	1	1	1	1	1	103342	
24	Vis CHC M6 x 40	Screw CHC M6 x 40	Schraube CHC M6 x 40	2/4	2/4	2/4	2/4	2/4	2/4	2/4	2/4	2/4	2/4	2/4	2/4	2/4	2/4	2/4	2/4	2/4	2/4	2/4	2/4	2/4	2/4	2/4	2/4	○	
25	Idem 24	Idem 24	Ebenso 24	2/4	2/4	2/4	2/4	2/4	2/4	2/4	2/4	2/4	2/4	2/4	2/4	2/4	2/4	2/4	2/4	2/4	2/4	2/4	2/4	2/4	2/4	2/4	2/4	○	
26	Rondelle 33'/63 M3 - 4G	Washer 33'/63 M3 - 4G	Unterlegscheibe 33'/63 M3 - 4G	1	1	1	1	1	1	1	1	1	1	1	1	1	1	1	1	1	1	1	1	1	1	1	1	065107	
27	Rondelle	Washer	Unterlegscheibe	1	1	1	1	1	1	1	1	1	1	1	1	1	1	1	1	1	1	1	1	1	1	1	○		
28	Vis CHC M5 x 12	Screw CHC M5 x 12	Schraube CHC M5 x 12	1	1	1	1	1	1	1	1	1	1	1	1	1	1	1	1	1	1	1	1	1	1	1	1	○	
29	Moteur (voir sous-ensemble M)	Motor (see M subassembly)	Motor (sehen M gesamtplan)	1	1	1	1	1	1	1	1	1	1	1	1	1	1	1	1	1	1	1	1	1	1	1	1	Page 165 Seite 165	
30	Vis HC M 6 - 8 8.8	Screw HC M 6 - 8 8.8	Schraube HC M 6 - 8 8.8	1	1	1	1	1	1	1	1	1	1	1	1	1	1	1	1	1	1	1	1	1	1	1	1	○	
31	1/2 Manchon côté moteur	Motor side coupling	Kupplungshälfte	1	1	1	1	1	1	1	1	1	1	1	1	1	1	1	1	1	1	1	1	1	1	1	1	065742	
32	Intercalaire	Plastic coupling	Kupplungstern	1	1	1	1	1	1	1	1	1	1	1	1	1	1	1	1	1	1	1	1	1	1	1	1	■	
33	Manchon ventilateur	Fan coupling	Ventilator Kupplungshälfte	1	1	1	1	1	1	1	1	1	1	1	1	1	1	1	1	1	1	1	1	1	1	1	1	103386	
34	Rondelle d'appui	Washer	Unterlegscheibe	1	1	1	1	1	1	1	1	1	1	1	1	1	1	1	1	1	1	1	1	1	1	1	1	065847	
35	Joint torique c 2,7 d 10,5 - Bague R10	O-ring c 2,7 d 10,5 - Ring R10	Dichtung c 2,7 d 10,5 - Ring R10	1	1	1	1	1	1	1	1	1	1	1	1	1	1	1	1	1	1	1	1	1	1	1	1	●	
36	Bague épaulée	Shouldered ring	Abnutzungsring	1	1	1	1	1	1	1	1	1	1	1	1	1	1	1	1	1	1	1	1	1	1	1	1	1	■
37	Idem 10	Idem 10	Ebenso 10	1/7	1/7	1/7	1/7	1/7	1/7	1/7	1/7	1/7	1/7	1/7	1/7	1/7	1/7	1/7	1/7	1/7	1/7	1/7	1/7	1/7	1/7	1/7	1/7	1	
38	Vis CHC M6 x 12	Screw CHC M6 x 12	Schraube CHC M6 x 12	1	1	1	1	1	1	1	1	1	1	1	1	1	1	1	1	1	1	1	1	1	1	1	1	○	
39	Porte joint	Seal holder	Lippendichtung-sockel	1	1	1	1	1	1	1	1	1	1	1	1	1	1	1	1	1	1	1	1	1	1	1	1	065744	
40	Joint à lèvres 15 x 25,5 x 4,6	Shaft seal 15 x 25,5 x 4,6	Lippendichtung 15 x 25,5 x 4,6	1	1	1	1	1	1	1	1	1	1	1	1	1	1	1	1	1	1	1	1	1	1	1	1	●	
41	Feutre	Felt	Filz	1	1	1	1	1	1	1	1	1	1	1	1	1	1	1	1	1	1	1	1	1	1	1	1	●	
42	Bâti	Central housing	Pumpenträger	1	1	1	1	1	1	1	1	1	1	1	1	1	1	1	1	1	1	1	1	1	1	1	1	103385	
42	Bâti	Central housing	Pumpenträger	1	1	1	1	1	1	1	1	1	1	1	1	1	1	1	1	1	1	1	1	1	1	1	1	103384	
43	Socle	Base	Fuss	1	1	1	1	1	1	1	1	1	1	1	1	1	1	1	1	1	1	1	1	1	1	1	1	103506	
44	Idem 10	Idem 10	Ebenso 10	2/7	2/7	2/7	2/7	2/7	2/7	2/7	2/7	2/7	2/7	2/7	2/7	2/7	2/7	2/7	2/7	2/7	2/7	2/7	2/7	2/7	2/7	2/7	2/7	○	
45	Vis CHC M6 x 16	Screw CHC M6 x 16	Schraube CHC M6 x 16	2	2	2	2	2	2	2	2	2	2	2	2	2	2	2	2	2	2	2	2	2	2	2	2	○	
46	Tube lest d'air	Gas ballast tube	Gasballastrohr	1	1	1	1	1	1	1	1	1	1	1	1	1	1	1	1	1	1	1	1	1	1	1	1	104631	
46	Tube lest d'air	Gas ballast tube	Gasballastrohr																									065842	
46	Tube lest d'air	Gas ballast tube	Gasballastrohr																									065839	
47	Joint torique c 1,9 - d 5,7 - Bague R5	O-ring c 1,9 - d 5,7 - Ring R5	Dichtung c 1,9 - d 5,7 - Ring R5	2	2	2	2	2	2	2	2	2	2	2	2	2	2	2	2	2	2	2	2	2	2	2	2	●	
48	Joint torique c 3 - d 28	O-ring c 3 - d 28	Dichtung c 3 - d 28	1	1	1	1	1	1	1	1	1	1	1	1	1	1	1	1	1	1	1	1	1	1	1	1	●	
49	Traversée de cuve	Oil case feedthrough	Ölbehälterdurchführung					1	1	1	1	1	1	1	1													102852	
49	Traversée de cuve	Oil case feedthrough	Ölbehälterdurchführung	1	1	1	1																					102853	
49	Traversée de cuve	Oil case feedthrough	Ölbehälterdurchführung																									100952	
50	Rondelle	Washer	Unterlegscheibe	2/4	2/4	2/4	2/4	2/4	2/4	2/4	2/4	2/4	2/4	2/4	2/4	2/4	2/4	2/4	2/4	2/4	2/4	2/4	2/4	2/4	2/4	2/4	2/4	○	

● Lot joints / Minor kit / Dichtungssatz

■ Lot maintenance / Major kit / Wartungssatz

○ Lot visserie / Screw kit / Schraubensatz

**Plan de montage cuve et bâti**  
**Oil casing and central housing assembly plan**  
**Ölbehälter und Pumpenträger Gesamtplan**

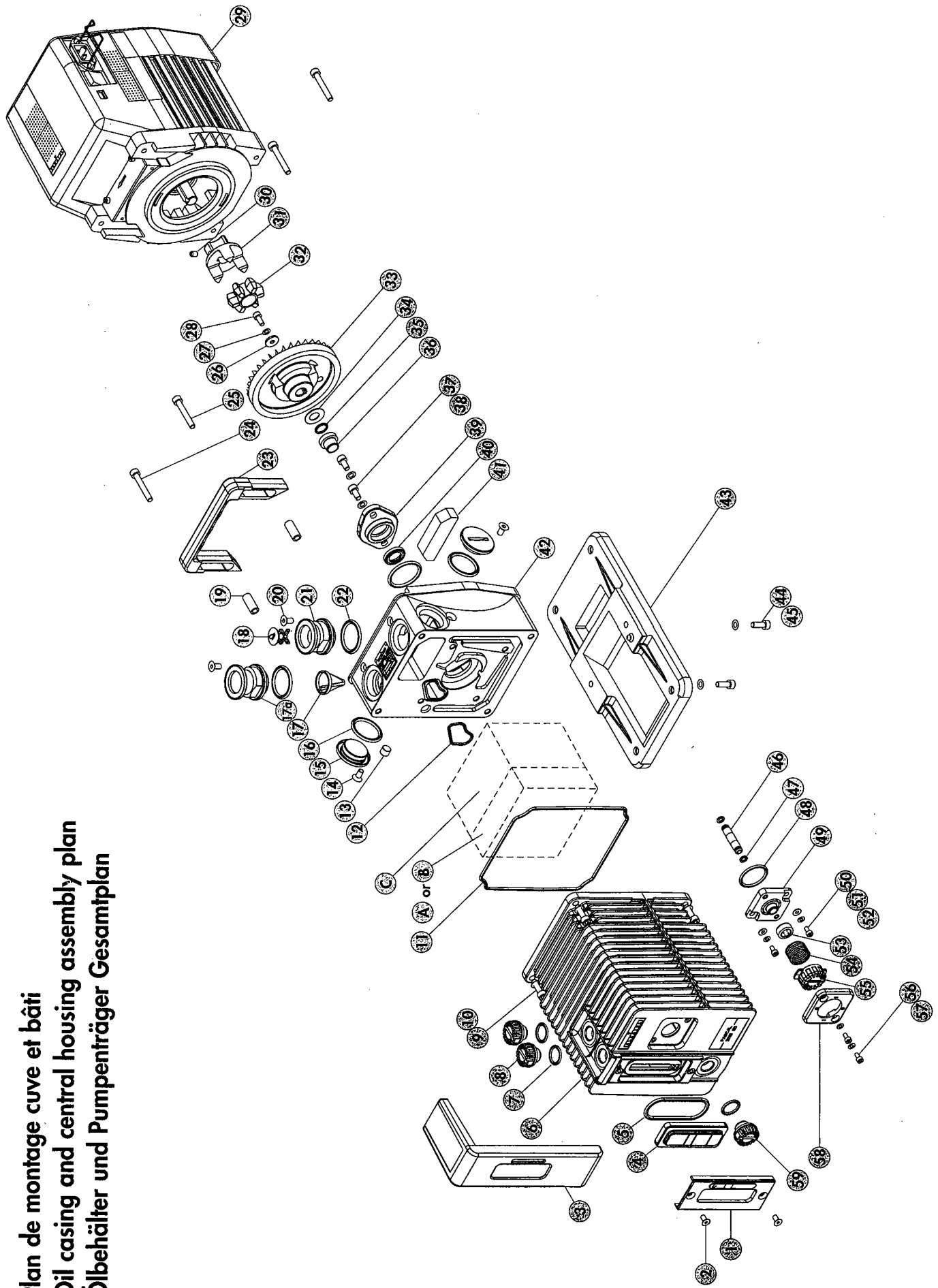

# Nomenclature cuve et bâti / Oil casing and central housing part list / Ölbehälter und Pumpenträger Nomenklatur

REP	DÉSIGNATION	SPECIFICATION	BENENNUNG	TYPES/MODEL																REF. P/N Bestell. Nr							
				2005 I	2010 I	2015 I	2021 I	2005 SD	2010 SD	2015 SD	2021 SD	1005 SD	1010 SD	1015 SD	1021 SD	2010 C2	2015 C2	2021 C2	2005 C1		2010 C1	2015 C1	2021 C1	1005 C1	1010 C1	1015 C1	1021 C1
51	Rondelle M4	Washer M4	Unterlegscheibe M4	2	2	2	2	2	2	2	2	2	2	2	2	2	2	2	2	2	2	2	2	2	2	2	○
52	Vis CHC M4 x 8	Screw CHC M4 x 8	Schraube CHC M4 x 8	2/4	2/4	2/4	2/4	2/4	2/4	2/4	2/4	2/4	2/4	2/4	2/4	2/4	2/4	2/4	2/4	2/4	2/4	2/4	2/4	2/4	2/4	2/4	○
53	Manchon lest d'air	Gas ballast sleeve	Gasballastmuffe	1	1	1	1	1	1	1	1	1	1	1	1	1	1	1	1	1	1	1	1	1	1	1	●
54	Ressort lest d'air	Gas ballast spring	Gasballastfeder	1	1	1	1	1	1	1	1	1	1	1	1	1	1	1	1	1	1	1	1	1	1	1	■
55	Bouchon de manoeuvre	Gas ballast knob	Gasballastknopf					1	1	1	1	1	1	1	1	1	1	1	1	1	1	1	1	1	1	1	102845
55	Bouchon de manoeuvre	Gas ballast knob	Gasballastknopf	1	1	1	1	1	1	1	1	1	1	1	1	1	1	1	1	1	1	1	1	1	1	1	102846
56	Idem 50	Idem 50	Ebenso 50	2/4	2/4	2/4	2/4	2/4	2/4	2/4	2/4	2/4	2/4	2/4	2/4	2/4	2/4	2/4	2/4	2/4	2/4	2/4	2/4	2/4	2/4	2/4	○
57	Idem 52	Idem 52	Ebenso 52	2/4	2/4	2/4	2/4	2/4	2/4	2/4	2/4	2/4	2/4	2/4	2/4	2/4	2/4	2/4	2/4	2/4	2/4	2/4	2/4	2/4	2/4	2/4	○
58	Couvercle lest d'air	Gas ballast cover	Gasballastdeckel					1	1	1	1	1	1	1	1	1	1	1	1	1	1	1	1	1	1	1	102850
58	Couvercle lest d'air	Gas ballast cover	Gasballastdeckel	1	1	1	1	1	1	1	1	1	1	1	1	1	1	1	1	1	1	1	1	1	1	1	102851
59	Idem 8	Idem 8	Ebenso 8	1/3	1/3	1/3	1/3	1/3	1/3	1/3	1/3	1/3	1/3	1/3	1/3	1/3	1/3	1/3	1/3	1/3	1/3	1/3	1/3	1/3	1/3	1/3	■

● Lot joints / Minor kit / Dichtungssatz

■ Lot maintenance / Major kit / Wartungssatz

○ Lot visserie / Screw kit / Schraubensatz



**Plan du bloc fonctionnel (C)**  
**Moving part plan (C)**  
**Pumpenblock Gesamtplan (C)**

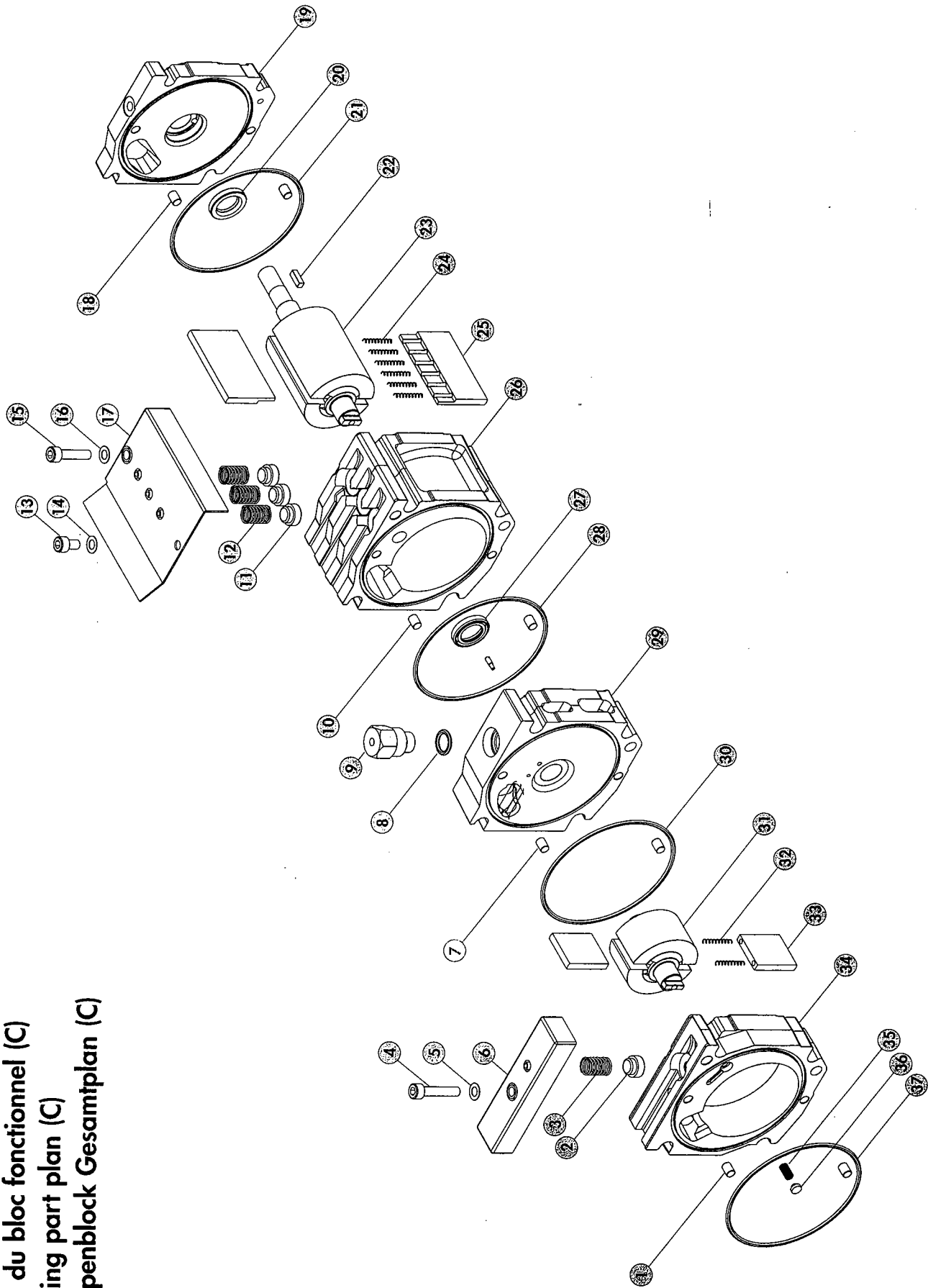

# Nomenclature du bloc fonctionnel / Moving parts part list / Pumpenblock Nomenklatur

				TYPES/MODEL																REF. P/N Bestell. Nr							
REP	DÉSIGNATION	SPECIFICATION	BENENNUNG	2005 I	2010 I	2015 I	2021 I	2005 SD	2010 SD	2015 SD	2021 SD	1005 SD	1010 SD	1015 SD	1021 SD	2010 C2	2015 C2	2021 C2	2005 C1		2010 C1	2015 C1	2021 C1	1005 C1	1010 C1	1015 C1	1021 C1
1	Goupille D6 LG8	Centering pin D6 LG8	Zentriersift	1/4	1/4	1/4	1/4	1/4	1/4	1/4	1/4					1/4	1/4	1/4	1/4	1/4	1/4	1/4					■
2	Soupape	Valve	Auslassventil	1	1/4	1/4	1/4	1	1/4	1/4	1/4					1/4	1/4	1/4	1	1/4	1/4	1/4					●
3	Ressort de soupape	Valve spring	Ventilfeder	1	1/4	1/4	1/4	1	1/4	1/4	1/4					1/4	1/4	1/4	1	1/4	1/4	1/4					■
4	Vis CHC M6 x 30	Screw CHC M6 x 30	Schraube CHC M6 x 30	1	1	1	1	1	1	1	1					1	1	1	1	1	1	1					○
5	Rondelle	Washer	Unterlegscheibe	1	1/3	1/3	1/3	1	1/3	1/3	1/3					1/3	1/3	1/3	1	1/3	1/3	1/3					○
6	Capot de soupape	Valve cover	Ventilgehäusedeckel	1	1	1	1	1	1	1	1					1	1	1	1	1	1	1					103521
7	Idem 1	Idem 1	Ebenso 1	1/4	1/4	1/4	1/4	1/4	1/4	1/4	1/4					1/4	1/4	1/4	1/4	1/4	1/4	1/4					■
8	Joint torique c 2,7 - d 12,1 - Bague R9	O-ring c 2,7 - d 12,1 - Ring R9	Dichtung c 2,7 - d 12,1 - Ring R9	1	1	1	1	1	1	1	1					1	1	1	1	1	1	1					●
9	Bouchon support capot	Cover holder	Gehäusedeckelhalter	1	1	1	1	1	1	1	1					1	1	1	1	1	1	1					103544
10	Idem 1	Idem 1	Ebenso 1	1/4	1/4	1/4	1/4	1/4	1/4	1/4	1/4	1/2	1/2	1/2	1/2	1/4	1/4	1/4	1/4	1/4	1/4	1/4	1/2	1/2	1/2	1/2	■
11	Idem 2	Idem 2	Ebenso 2	3/4	3/4	3/4	3/4	3/4	3/4	3/4	3/4	3	3	3	3	3/4	3/4	3/4	3/4	3/4	3/4	3/4	3	3	3	3	●
12	Idem 3	Idem 3	Ebenso 3	3/4	3/4	3/4	3/4	3/4	3/4	3/4	3/4	3	3	3	3	3/4	3/4	3/4	3/4	3/4	3/4	3/4	3	3	3	3	■
13	Vis CHC M6 x 10	Screw CHC M6 x 10	Schraube CHC M6 x 10	1	1	1	1	1	1	1	1	1	1	1	1	1	1	1	1	1	1	1	1	1	1	1	○
14	Idem 5	Idem 5	Ebenso 5	1/3	1/3	1/3	1/3	1/3	1/3	1/3	1/3	1/2	1/2	1/2	1/2	1/3	1/3	1/3	1/3	1/3	1/3	1/3	1/2	1/2	1/2	1/2	○
15	Vis CHC M6 x 25	Screw CHC M6 x 25	Schraube CHC M6 x 25	1	1	1	1	1	1	1	1	1	1	1	1	1	1	1	1	1	1	1	1	1	1	1	○
16	Idem 5	Idem 5	Ebenso 5	1/3	1/3	1/3	1/3	1/3	1/3	1/3	1/3	1/2	1/2	1/2	1/2	1/3	1/3	1/3	1/3	1/3	1/3	1/3	1/2	1/2	1/2	1/2	○
17	Capot de soupape	Valve cover	Ventilgehäusedeckel	1				1								1			1								103523
17	Capot de soupape	Valve cover	Ventilgehäusedeckel			1				1						1			1								103525
17	Capot de soupape	Valve cover	Ventilgehäusedeckel				1				1										1						103394
17	Capot de soupape	Valve cover	Ventilgehäusedeckel									1										1					103521
17	Capot de soupape	Valve cover	Ventilgehäusedeckel										1										1				104309
17	Capot de soupape	Valve cover	Ventilgehäusedeckel											1										1			104310
17	Capot de soupape	Valve cover	Ventilgehäusedeckel												1										1		104311
18	Idem 1	Idem 1	Ebenso 1	1/4	1/4	1/4	1/4	1/4	1/4	1/4	1/4	1/2	1/2	1/2	1/2	1/4	1/4	1/4	1/4	1/4	1/4	1/4	1/2	1/2	1/2	1/2	■
19	Flasque avant assemblée	Equipped front plate	Einrichtung vorderer Flansche	1	1	1	1	1	1	1	1	1	1	1	1												103401
19	Flasque avant assemblée	Equipped front plate	Einrichtung vorderer Flansche													1	1	1	1	1	1	1	1	1	1	1	103396
20	Joint à lèvres 15 x 25,5 x 4,6	Shaft seal 15 x 25,5 x 4,6	Lippendichtung 15 x 25,5 x 4,6	1/2	1/2	1/2	1/2	1/2	1/2	1/2	1/2	1	1	1	1	1/2	1/2	1/2	1/2	1/2	1/2	1/2	1	1	1	1	●
21	Joint torique c 2 - d 90	O-ring c 2 - d 90	Dichtung c 2 - d 90	1/4	1/4	1/4	1/4	1/4	1/4	1/4	1/4	1/2	1/2	1/2	1/2	1/4	1/4	1/4	1/4	1/4	1/4	1/4	1/2	1/2	1/2	1/2	●
22	Clavette Parallèle A4 x 4 x 12	Shaft key A4 x 4 x 12	Nutenstein A4 x 4 x 12	1	1	1	1	1	1	1	1	1	1	1	1	1	1	1	1	1	1	1	1	1	1	1	■
23	Rotor BP	LP rotor	Niederdruckrotor	1				1																			065745
23	Rotor BP	LP rotor	Niederdruckrotor		1				1																		065749
23	Rotor BP	LP rotor	Niederdruckrotor			1				1																	065750
23	Rotor BP	LP rotor	Niederdruckrotor				1				1																065751
23	Rotor BP	LP rotor	Niederdruckrotor									1															103880

● Lot joints / Minor kit / Dichtungssatz

■ Lot maintenance / Major kit / Wartungssatz

○ Lot visserie / Screw kit / Schraubensatz



**Plan du bloc fonctionnel (C)**  
**Moving part plan (C)**  
**Pumpenblock Gesamtplan (C)**

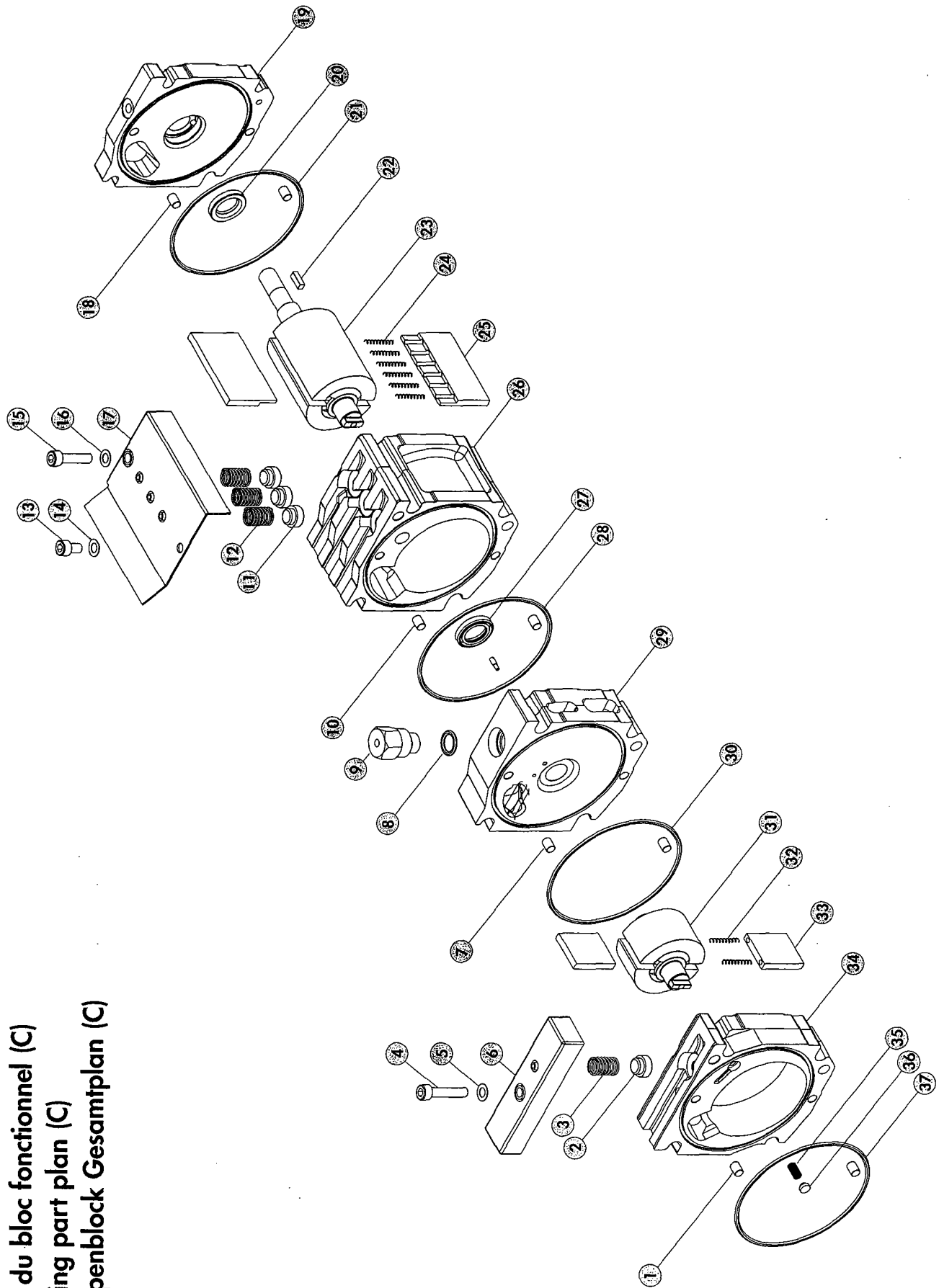

# Nomenclature du bloc fonctionnel / Moving parts part list / Pumpenblock Nomenklatur

				TYPES/MODEL																								
REP	DÉSIGNATION	SPECIFICATION	BENENNUNG	2005 I	2010 I	2015 I	2021 I	2005 SD	2010 SD	2015 SD	2021 SD	1005 SD	1010 SD	1015 SD	1021 SD	2010 C2	2015 C2	2021 C2	2005 C1	2010 C1	2015 C1	2021 C1	1005 C1	1010 C1	1015 C1	1021 C1	REF. P/N Bestell. Nr	
23	Rotor BP	LP rotor	Niederdruckrotor									1															100631	
23	Rotor BP	LP rotor	Niederdruckrotor										1														103569	
23	Rotor BP	LP rotor	Niederdruckrotor											1													105568	
23	Rotor BP	LP rotor	Niederdruckrotor													1				1							065801	
23	Rotor BP	LP rotor	Niederdruckrotor														1				1						065802	
23	Rotor BP	LP rotor	Niederdruckrotor															1				1					065803	
23	Rotor BP	LP rotor	Niederdruckrotor																1								065601	
23	Rotor BP	LP rotor	Niederdruckrotor																				1				103397	
23	Rotor BP	LP rotor	Niederdruckrotor																					1			103399	
23	Rotor BP	LP rotor	Niederdruckrotor																						1		103400	
23	Rotor BP	LP rotor	Niederdruckrotor																						1		103407	
24	Ressort de palette	Vane spring	Schieberfeder	2/4	4/6	6/8	6/8	2/4	4/6	6/8	6/8	2	4	6	6	4/6	6/8	6/8	2/4	4/6	6/8	6/8	2	4	6	6	■	
25	Palette BP	LP vane	Niederdruckscheiber	2	2	2	2	2	2	2	2	2	2	2	2	2	2	2	2	2	2	2	2	2	2	2	2	■
26	Stator BP	LP stator	Niederdruckstator	1				1											1									103507
26	Stator BP	LP stator	Niederdruckstator		1				1											1								103512
26	Stator BP	LP stator	Niederdruckstator			1				1											1							103510
26	Stator BP	LP stator	Niederdruckstator				1				1											1						103393
26	Stator BP	LP stator	Niederdruckstator									1											1					103409
26	Stator BP	LP stator	Niederdruckstator										1											1				103881
26	Stator BP	LP stator	Niederdruckstator											1											1			103882
26	Stator BP	LP stator	Niederdruckstator												1											1		103883
27	Idem 20	Idem 20	Ebenso 20	1/2	1/2	1/2	1/2	1/2	1/2	1/2	1/2					1/2	1/2	1/2	1/2	1/2	1/2	1/2	1/2	1/2	1/2	1/2	●	
28	Idem 21	Idem 21	Ebenso 21	1/4	1/4	1/4	1/4	1/4	1/4	1/4	1/4	1/2	1/2	1/2	1/2	1/4	1/4	1/4	1/4	1/4	1/4	1/4	1/4	1/4	1/4	1/4	1/2	●
29	Flasque médian	Central plate	Zwischenflansche	1	1	1	1	1	1	1	1									1	1	1	1					103408
29	Flasque médian	Central plate	Zwischenflansche																		1	1	1	1				103410
30	Idem 21	Idem 21	Ebenso 21	1/4	1/4	1/4	1/4	1/4	1/4	1/4	1/4					1/4	1/4	1/4	1/4	1/4	1/4	1/4	1/4	1/4	1/4	1/4	●	
31	Rotor HP	HP rotor	Hochdruckrotor					1	1	1	1																	065852
31	Rotor HP	HP rotor	Hochdruckrotor	1	1	1	1																					103417
31	Rotor HP	HP rotor	Hochdruckrotor																		1	1	1	1				102854
32	Idem 24	Idem 24	Ebenso 24	2/4	2/6	2/8	2/8	2/4	2/6	2/8	2/8					2/6	2/8	2/8	2/4	2/6	2/8	2/8					■	
33	Palette HP	HP vane	Hochdruckscheiber	2	2	2	2	2	2	2	2					2	2	2	2	2	2	2	2				■	
34	Stator HP	HP stator	Hochdruckstator	1	1	1	1	1	1	1	1					1	1	1	1	1	1	1	1				103409	
35	Ressort clapet anti-retour	Spring of the anti-suck-back	Federrückschlagventil	1	1	1	1	1	1	1	1	1	1	1	1	1	1	1	1	1	1	1	1	1	1	1	■	
36	Clapet anti-retour	Anti-suck-back device	Rückschlagventil	1	1	1	1	1	1	1	1	1	1	1	1	1	1	1	1	1	1	1	1	1	1	1	●	
37	Idem 21	Idem 21	Ebenso 21	1/4	1/4	1/4	1/4	1/4	1/4	1/4	1/4					1/4	1/4	1/4	1/4	1/4	1/4	1/4	1/4	1/4	1/4	1/4	1	●

● Lot joints / Minor kit / Dichtungssatz

■ Lot maintenance / Major kit / Wartungssatz

○ Lot visserie / Screw kit / Schraubensatz

**Plan du système de lubrification pompe à huile (A)**  
**Oil pump system plan (A)**  
**Ölpumpsystem Gesamtplan (A)**

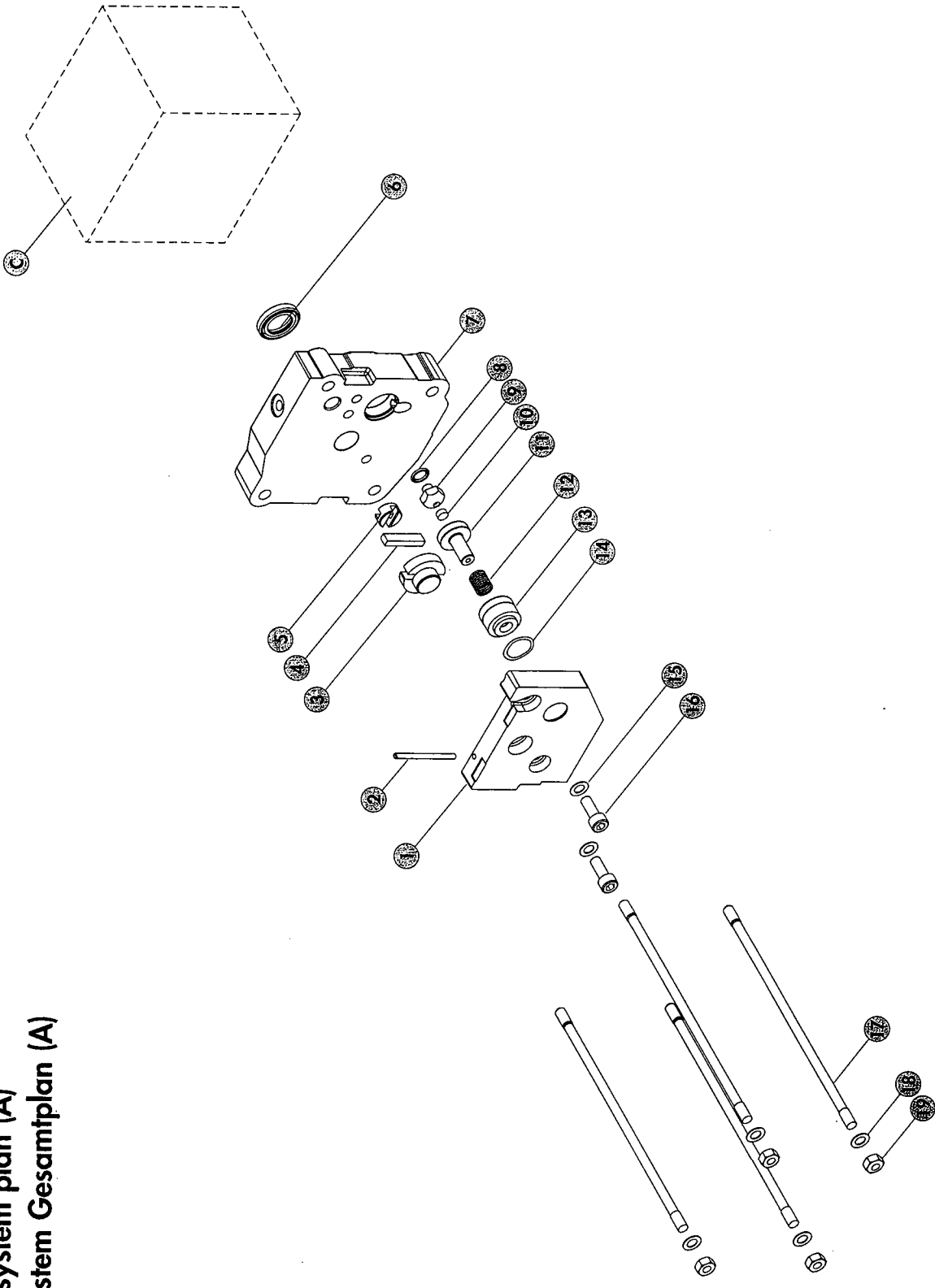





**Plan du système de lubrification levier moulinet (B)**

**Oil system plan (B)**

**Ölpumpsystem Gesamtplan (B)**

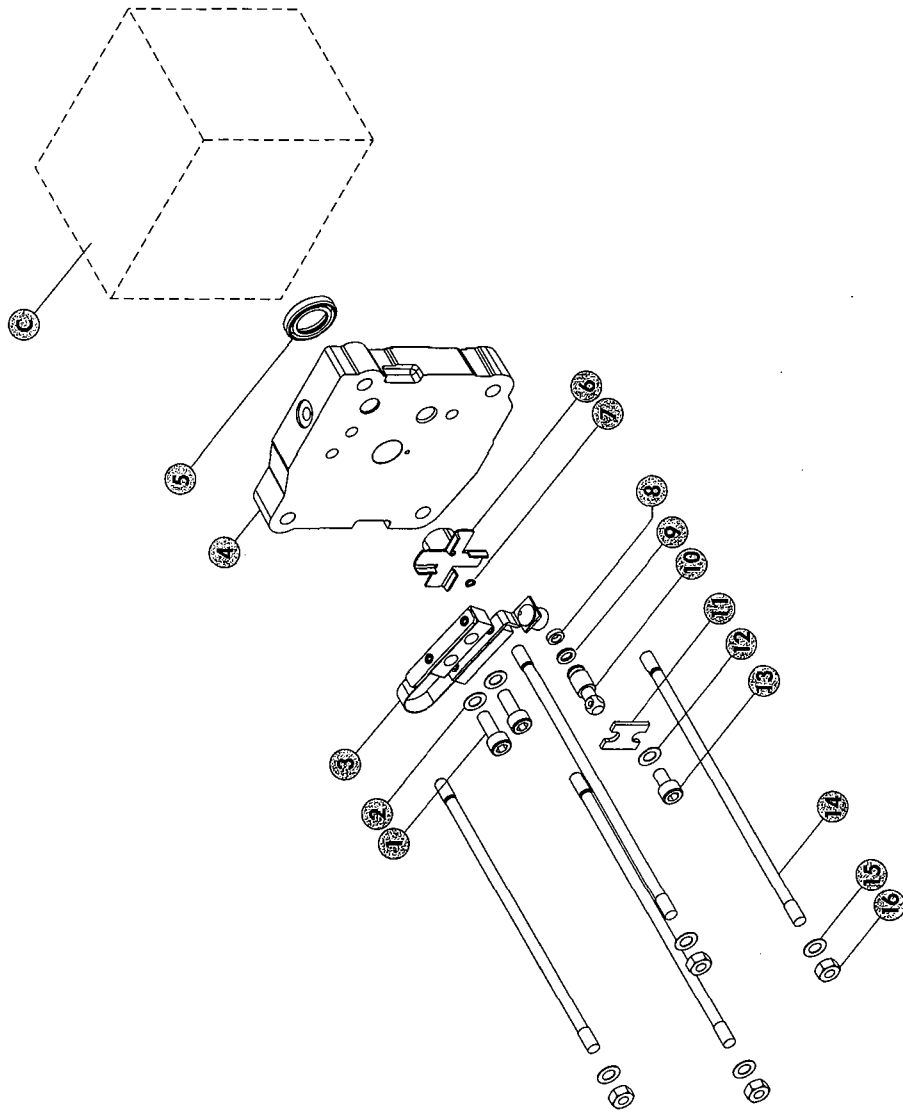

# Nomenclature du système de lubrification levier moulinet / Oilsystem part list / Ölpumpsystem Nomenklatur

REP	DÉSIGNATION	SPECIFICATION	BENENNUNG	TYPES/MODEL						REF. P/N Bestell. Nr
				2005 SD	2010 SD	2015 SD	2021 SD	1015 SD	1021 SD	
1	Vis CHC M6 x 16	Screw CHC M6 x 16	Schraube CHC M6 x 16	2	2	2	2	2	2	○
2	Rondelle	Washer	Unterlegscheibe	4/7	4/7	4/7	4/7	4/7	4/7	○
3	Levier oscillant	Equipped lever	Hebel	1	1	1	1	1	1	■
4	Flasque arrière	Rear plate	Hintererflansche	1	1	1	1	1	1	103485
5	Joint à lèvres D 15 x 25,5 x 4,6	Shaft seal 15 x 25,5 x 4,6	Lippendichtung 15 x 25,5 x 4,6	1	1	1	1	1	1	●
6	Came moulinet	Impeller	Flügelnocke	1	1	1	1	1	1	052721
7	Bague d'arrêt freinax	Clips	Sprengring	1	1	1	1	1	1	071161
8	Rondelle	Washer	Unterlegscheibe	1	1	1	1	1	1	052758
8	Gicleur	Jet	Düse	1	1	1	1	1	1	102910
9	Joint torique c 1,9 - d 5,7 - Bague R5	O-ring c 1,9 - d 5,7 - Ring R5	Dichtung c 1,9 - d 5,7 - Ring R5	1	1	1	1	1	1	●
10	Siège de clapet	Seat	Ventilsitz	1	1	1	1	1	1	052718
11	Bride	Flange	Klammer	1	1	1	1	1	1	052569
12	Idem 2	Idem 2	Ebenso 2	1/7	1/7	1/7	1/7	1/7	1/7	○
13	Vis CHC M6 x 10	Screw CHC M6 x 10	Schraube CHC M6 x 10	1	1	1	1	1	1	○
14	Goujon M6-129 / 19	Pin M6-129 / 19	Stift M6-129 / 19	4						102855
14	Goujon M6-142 / 12	Pin M6-142 / 12	Stift M6-142 / 12		4					065806
14	Goujon M6-164 / 12	Pin M6-164 / 12	Stift M6-164 / 12			4				065805
14	Goujon M6-187 / 12	Pin M6-187 / 12	Stift M6-187 / 12				4			065804
14	Goujon M6-72 / 19	Pin M6-72 / 19	Stift M6-72 / 19					4		065636
14	Goujon M6-84 / 12	Pin M6-84 / 12	Stift M6-84 / 12						4	103522
15	Idem 2	Idem 2	Ebenso 2	2/7	2/7	2/7	2/7	2/7	2/7	○
16	Ecrou HM6	Screw nut HM6	Mutter HM6	4	4	4	4	4	4	○

● Lot joints / Minor kit / Dichtungssatz

■ Lot maintenance / Major kit / Wartungssatz

○ Lot visserie / Screw kit / Schraubensatz

## Sous-ensemble B / Subassembly B / Gesamtplan B

**Plan ensemble motorisation (M)**  
**Motor assembly plan (M)**  
**Motor Gesamtplan (M)**

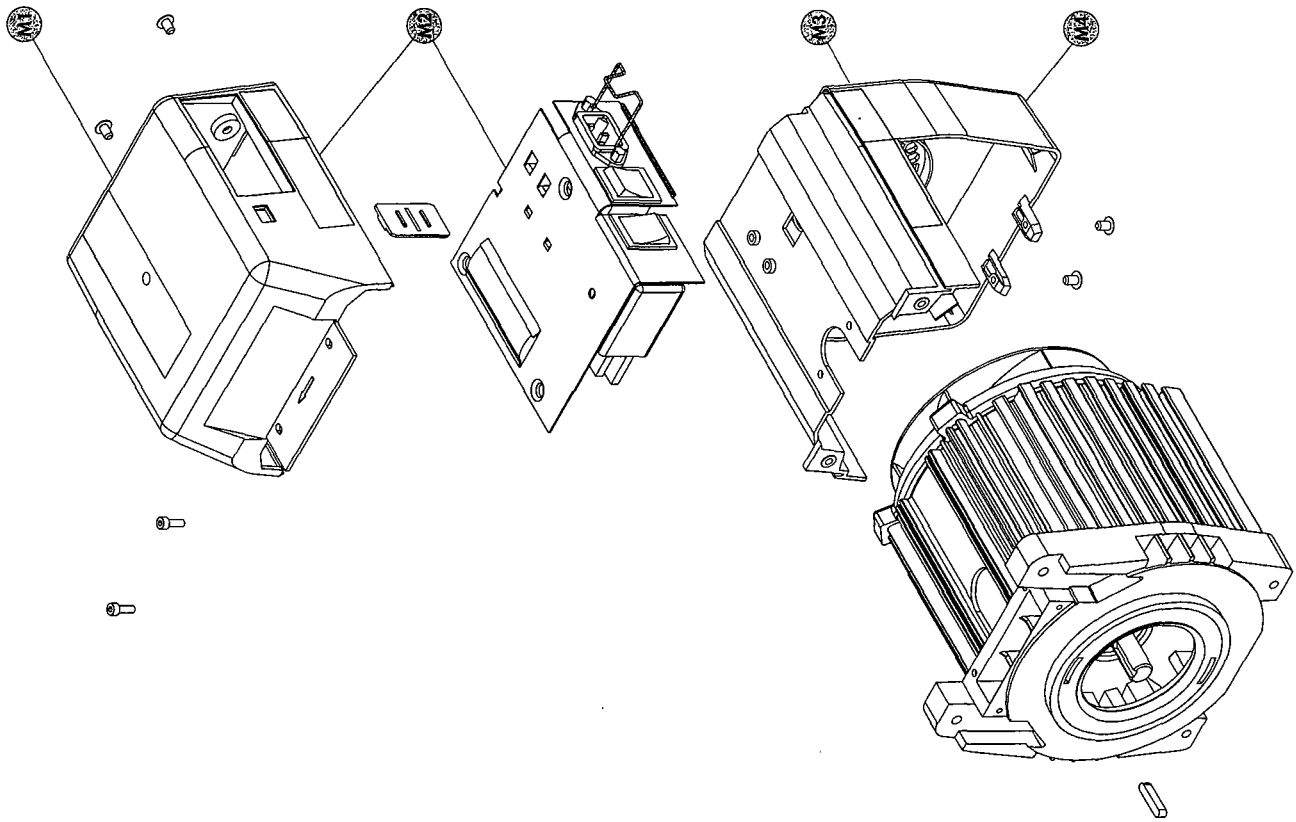

# Nomenclature ensemble motorisation (M) / Motor assembly part list (M) / Motor Gesamtheit Nomenklatur (M)

## MOTEUR UNIVERSEL / UNIVERSAL MOTOR / UNIVERSELLE MOTOR

REP	DÉSIGNATION	SPECIFICATION	BENENNUNG	REF. P/N Bestell. Nr
	Moteur monophasé standard	Single phase motor	Wechselstrommotor	103749
	Moteur triphasé standard	Three-phase motor	Drehstrommotor	103748
	Moteur sans interrupteur	Motor without switch	Motor ohne schalter	105132
	Moteur avec variateur	Motor with variator	Motor mit variator	103751
M1	Capot nu + visserie	Upper cover + assembly screws	Motor-abdeckung + Schrauben	104921
M2	Capot équipé + visserie	Equipped upper cover + assembly screws	Abdeckung mit elektrische Einrichtung	104922
M3	Ventilateur moteur	Fan	Einlüfter	104923
M4	Carter principal + visserie	Main frame + assembly screws	Motorfahrgestell	104920

## AUTRES MOTEURS / OTHER MOTORS / ANDERE MOTORS

REP	DÉSIGNATION	SPECIFICATION	BENENNUNG	REF. P/N Bestell. Nr
	Moteur monophasé à bride CEI	Single phase motor with CEI flange	Wechselstrommotor mit CEI Klammer	
	Moteur triphasé à bride CEI	Three-phase motor with CEI flange	Drehstrommotor mit CEI Klammer	
	Support moteur bride CEI	CEI flange motor mounting plate	CEI Klammer Motorflansche	103652
	Vis CHC M8 x 20	Screw CHC M8 x 20	Schraube CHC M8 x 20	075514
	Rondelle	Washer	Unterlegscheibe	073455

Des moteurs spéciaux sont disponibles sur demande (anti-déflagrant...)

Specific motors are available on request (Explosion-proof...)

Spezialmotore (z.B. explosionsgeschützt) sind auf Anfrage erhältlich

Plan du système bulleur  
 Bubbler system plan  
 Bubbler system Gesamtplan

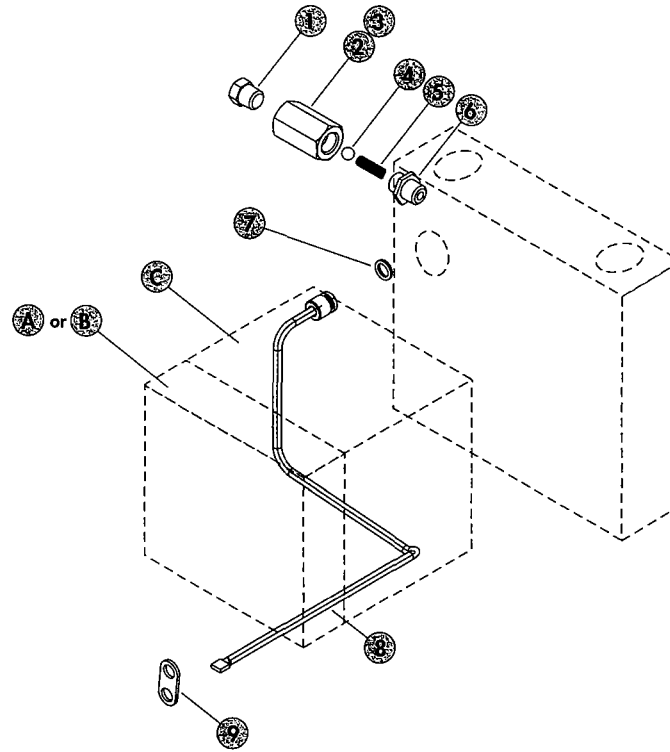

Nomenclature du système bulleur / Bubbler system part list / Bubbler system Nomenklatur

REP	DÉSIGNATION	SPECIFICATION	BENENNUNG	TYPES/MODEL			REF. P/N Bestell. Nr
				2010 C2	2015 C2	2021 C2	
1	Bouchon 1/8 NPT	Plug 1/8 NPT	Blindstopfen 1/8 NPT	1	1	1	082926
2	Manchon	Coupling	Kupplung	1	1	1	065866
3	Ruban teflon	Teflon band	Teflon band	1	1	1	060975
4	Bille inox 18/8 d. 5,8	Ball 18/8 d. 5.8	Kugel 18/8 d. 5,8	1	1	1	087593
5	Ressort	Spring	Feder	1	1	1	065149
6	Raccord G 1/8 -1/8 NPT	Connector G 1/8 -1/8 NPT	Verbindungselement	1	1	1	065867
7	Joint torique c.1,9 - d 7,2	O-ring c.1.9 - d 7.2	Dichtung c 1,9 - d 7,2	1	1	1	●
8	Bulleur	Bubbler	Bubler	1	1		065836
8	Bulleur	Bubbler	Bubler			1	065835
9	Attache tube	Tube fastener	Rohrbefestigung	1	1	1	065865

● Lot joints / Minor kit / Dichtungssatz

■ Lot maintenance / Major kit / Wartungssatz

○ Lot visserie / Screw kit / Schraubensatz

## Table of recommended oils

### Recommended oils

In the vane pumps, we recommend to use only the ALCATEL oils in the table below:

OIL	APPLICATION	1	SD	C1	C2	Total ultimate pressure (mbar)	Viscosity mm <sup>2</sup> /s (cst)	Vapour tension 25°C (mbar)	Flash point/self-ignition temperature
ALCATEL 102	Anti-emulsion mineral oil - Drying - Pumping water vapour - Freeze-drying					≤ 3.10 <sup>-2</sup>	40°C/98 100°C/11.1	< 1.10 <sup>-3</sup>	230°C 260°C
ALCATEL 111	Hydro-carbon based synthetic oil with good heat resistance: - Pumping at high pressures - Operating at high ambient temperatures					≤ 1.10 <sup>-2</sup>	40°C/100 100°C/7.8	< 1.10 <sup>-3</sup>	212°C 245°C
ALCATEL 113	Highly stable synthetic oil. Perfluoropolyether. - Highly inert to chemicals - Pumping oxygen - Plasma etching					≤ 5.10 <sup>-3</sup>	40°C/90 100°C/11	< 3.10 <sup>-5</sup>	none none
ALCATEL 119	Mineral oil distilled under vacuum - Pumping non-corrosive products - Low viscosity					≤ 3.10 <sup>-3</sup>	40°C/54 100°C/8.1	< 4.10 <sup>-5</sup>	213°C 244°C
ALCATEL 120	General-purpose paraffin-based refined mineral oil - Good ultimate pressure - Low backstreaming					≤ 2.10 <sup>-3</sup>	40°C/120 100°C/12.5	< 4.10 <sup>-5</sup>	260°C 295°C
ALCATEL 121	Special hydrocarbon based mineral oil					≤ 3.10 <sup>-3</sup>	40°C/64 100°C/10	< 1.33.10 <sup>-7</sup>	268°C 296°C
ALCATEL 200	Mineral oil distilled under vacuum: - Pumping corrosive products - Low backstreaming					≤ 2.10 <sup>-2</sup>	40°C/58 100°C/8.5	< 1.10 <sup>-5</sup>	223°C 259°C
ALCATEL 300	Hydrocarbon-based mineral oil distilled under vacuum: Pumping corrosive products - Plasma etching - Operating at high temperatures					≤ 5.10 <sup>-3</sup>	40°C/56 100°C/8.9	< 1.10 <sup>-5</sup>	243°C 270°C

\* Ultimate pressure measured according to Pneurop 6602 specifications on 2015 ALCATEL pump.

These values are given as a rough guide only. They may vary according to the type of pump and the pumping conditions.

☞ Requires special preparation of pump (see page 88).

However, the following replacement fluids can be used:

#### Mineral oil:

ELF MOVIXA PV 100, TURBELF SA 100,  
BP CS 100 (BP registered trademark)  
SHELL VITREA 100 (SHELL registered trademark)  
TOTAL CORTIS PV 100 (TOTAL registered trademark)  
INLAND 19, INLAND 20 (INLAND registered trademark)  
MR 200 (MATSUMURA registered trademark)

#### Mineral-based synthetic oils:

ELF BARELF F 100, ELF BARELF C 68 (ELF registered trademark)  
INVOIL 20 (INLAND registered trademark)  
INLAND TW (INLAND registered trademark)  
ELITE Z (CAMBRIGE MILL PRODUCTS, INC. reg. trademark)

#### Ester type synthetic oils:

ANDEROL 555 (HÜLS registered trademark)  
ANDEROL RCF 96 N (HÜLS registered trademark)

#### Fluorocarbon synthetic oils:

FOMBLIN YL VAC 25-6 (MONTEDISON registered trademark)  
KRYTOX 15-25 (DU PONT DE NEMOURS registered trademark)  
HALOVAC 100 (HALOCARBON registered trademark)  
AFLUNOX 15.25 (SCM registered trademark)

Note: In this case, pump performances may be slightly different from those given in pages 59, 60, 61.

Start-up

## Filling with oil

Alcatel 5 to 21 m<sup>3</sup>/h I, SD, C1 series pumps are tested in the factory with **ALCATEL 120** oil (or Alcatel 119 for USA).

Alcatel 5 to 21 m<sup>3</sup>/h C2 series pumps are tested in the factory with **Alcatel 113** oil.

At delivery, there is some oil remaining in the functional block.



Our pumps are tested in the factory with Alcatel oil: it is recommended to use the same oil during operation. To change the type of oil, refer to the Maintenance Chapter, "replacement of type of oil" section.

**In all cases, follow the recommendations of the pump specifier for the choice of oil to be used.**

If necessary, carry out the special preparation procedure for the pump, then, remove the filling cap and fill with oil until the oil reaches the highest mark on the sight glass.

This operation must be performed with the pump switched off. The second filling orifice is used if an external oil filtration device is connected (*see accessories p. 63*).

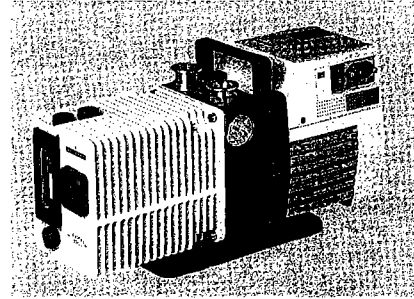

## Checking the oil level

To use the pump in optimum conditions, the oil level must be observed and checked regularly. This level is checked with the pump switched off, hot and on a horizontal plane.

Oil level sight glass for  
"I", "C1, C2" series and  
1015 SD, 1021 SD pumps

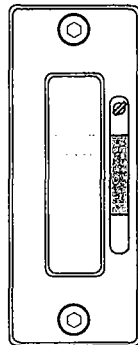

Maximum level

Minimum level

Oil level sight glass for  
"SD" series pumps except 1015 SD,  
1021 SD



Maximum level  
Minimum level

Note: Optimum pump performance and service life are obtained when the oil level is between the maximum level and the minimum level.



## Mechanical connections



For a given application, pump performance, vacuum characteristics, temperature and reliability depend on the following:

- assembly conditions, accessory filters,
- the oil used,
- mechanical connections: pipes, etc.
- maintenance frequency and quality.

For the assembly of the vacuum circuit, provide the accessories required for maintenance: valves, purges, etc.

## Mounting on a frame

The pump can be mounted on a frame using the 4 attachment holes on the base and the shock mounts supplied.

**Note:** Special shock mounts, effective against the pump's own vibrations, can also be used but they do not ensure correct attachment during the transfer of equipment. In this case, the pump should be clamped onto its support.

## Ventilation

The pump and the motor are each equipped with a ventilation system. During pump installation, the pump should be placed in ventilated place. Provide a minimum gap of 25 mm around the pump.

**The vents on the pump and the motor should be checked regularly to ensure that they are not blocked.**

Pascal Series ALCATEL pumps are designed for operation at an ambient temperature between 53°F and 113°F (12 and 45°C).

## Inlet and exhaust fitting



Remove the protective caps on the inlet and exhaust orifices; these components prevent foreign bodies from entering the pump during transport and storage. **It is dangerous to leave them on the pump during operation.**

The pump inlet and exhaust orifices are equipped with DN 25 ISO-KF end fittings which can be used to fit various line components made of stainless steel, plastic, etc. (see Alcatel catalog).

### Inlet



Make sure that all the components or chamber connected to the pump inlet withstand a negative pressure of 1 bar relative to atmospheric pressure.

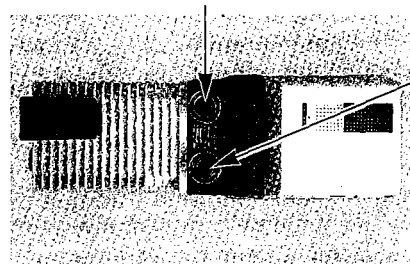

Also make sure that the maximum excess pressure does not exceed 1 bar relative to atmospheric pressure (for security).

### Exhaust



It is recommended to connect the pump exhaust to a smoke evacuation duct.

- If the pump exhaust orifice is connected to an extraction duct or an oil mist eliminator, the exhaust stop valve fitted in the pump exhaust orifice must be removed.
- At the pump exhaust, the evacuation circuit must be such that the resulting excess pressure in the oil case is as low as possible; for correct pump operation the max. exhaust pressure recommended should be 1,125 Torr (1.5 bar) absolute pressure.

## Changing position of inlet and exhaust fittings

Depending on the types of accessories used and the pumping conditions, these orifices can be fitted vertically on the pump or horizontally as shown on the diagram below.

Note: The pump is supplied in configuration A.

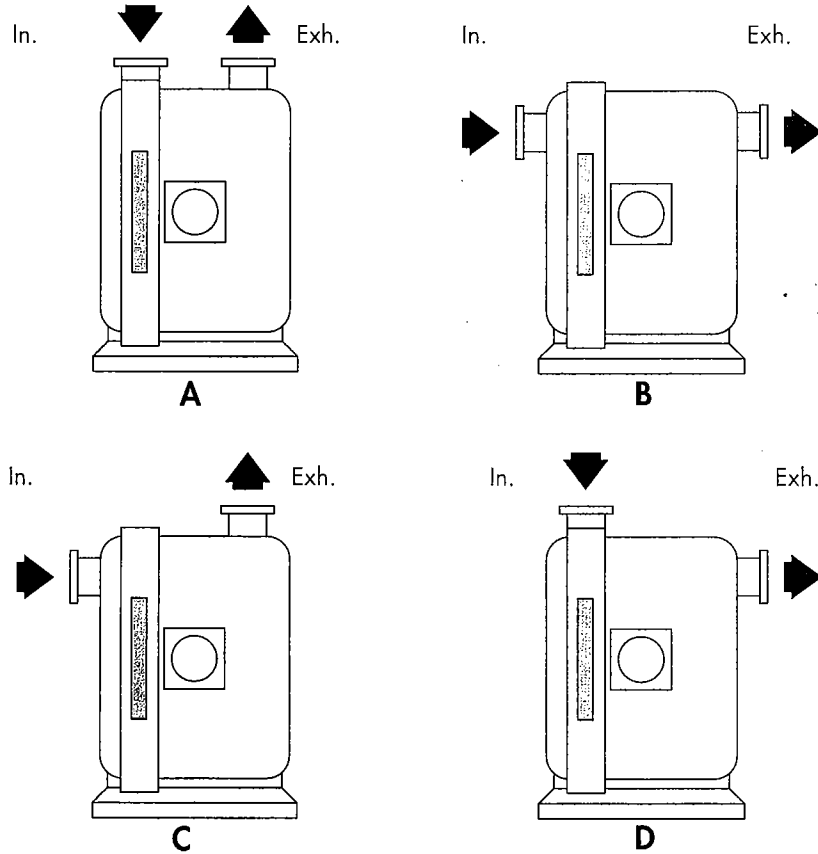

## Disassembling the fittings

**4** Unfasten the attachment screw from the end fitting to be removed.

**30** Unfasten the end fitting and remove it from its housing along with the O-ring. In the case of the inlet end fitting, also remove the inlet filter.

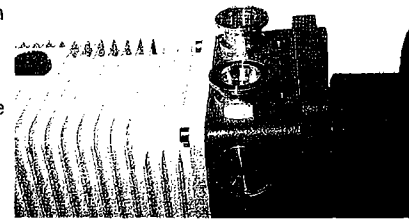

## Horizontal reassembly

**4** Remove the attachment screw from the lateral cap and using a wide screwdriver, remove the cap.

- Position the end fitting in the corresponding lateral orifice taking care to fit the O-ring.

Attach the end fitting with the screw.

In the case of the inlet end fitting, fit the filter at the bottom of the orifice.

- Close unused orifices with plugs and fasten the screws.

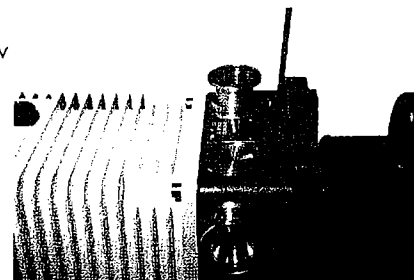

## Electrical connections



The pumps must be connected to an electrical installation in compliance with the decree 88-1056 dated 14 November 1988, as well as any local electrical codes that apply.

- Our products are designed to meet current EEC regulations. **Any modification on the part of the user** is liable to cause non-compliance with regulations or even affect the EMC (Electromagnetic compatibility) performance and safety of the product. Alcatel cannot be held responsible for consequences resulting from such an intervention.
- Before any maintenance is performed on a product by a maintenance operator who has not been trained on safety regulations (EMC, electrical safety, chemical pollution, etc.), isolate the product from its various energy sources (electricity, compressed air, etc.).
- **As a general rule, it is recommended to protect the motor for 120% of its nominal current (see page 72).**
- Check that the electrical wiring and the voltage selector position of the motor correspond to the line voltage, before starting up the pump.
- Ensure that the electrical installation conforms with your local safety requirements. It must include the appropriate fuse and reliable earthground.

### Three-phase version

Electrical motor is in accordance with major international standards (UL, CSA, CE) and offers two voltage ranges:

- Low voltage: 170 V to 254 V 50Hz - 170 V to 300 V 60Hz,
- High voltage: 342 V to 460 V 50Hz - 342 V to 520 V 60Hz.

**All three phase motors (protection level IP 43, TEFC type) must be protected by a customer supplied starter consisting of a suitably rated contactor and thermal overload.**

Furthermore, they are equipped with a dry contact (NC) thermal protection which is available in the terminal box.

Wire the motor according to the line voltage. The connections to be made are shown on a diagram inside the terminal box or on its lid.

Check the direction of rotation of the motor (direction of arrow located on the motor cover). For this:

- Remove the protective caps on the inlet and exhaust orifices.
  - Vent the pump to atmospheric pressure.
  - Switch on the pump for 2 to 3 seconds, with your hand on the inlet orifice if suction is felt, the wiring is correct.
- Otherwise, invert 2 consecutive phases.

The earth terminal must be connected correctly.

### Single-phase version

Electrical motor is in accordance with major international standards (UL, CSA, CE) and offers two voltage ranges:

- Low voltage: 90 V to 132 V 50/60Hz,
- High voltage: 180 V to 254 V 50/60Hz.

**Note: single-phase motors (protection level IP 43 - TEFC type) have a thermal circuit interruptor with an automatic starting device: when the internal motor temperature reaches a value over the preset limit value, the motor stops.**

**However, when the motor is cooled, it will start up again automatically.**

Before connecting to the mains, check the position of the voltage selector: High Voltage (HV) or Low Voltage (LV) (see table page 73).

**The plug is equipped with a ground pin which must be connected.**

The motor rotation direction is set at the factory.

## External motor protection, electrical protection

### Motor characteristics, connection, protection

The information below is given as a recommendation.

The user must comply with the electrical standards or recommendations (IEC, VDE, UL, CSA, etc.) applicable in the country in which the pump is used.

The use of electrical protection for the pump motor makes it possible to protect:

- The motor: in the event of excess voltage or rotor blocking, the resulting excess current may destroy the coil and possibly the start-up system (for a single-phase motor).
- The pump: in the event of a lubrication fault (contaminated oil, presence of particles), increased resistance will draw excessive motor current.

Differential thermal circuit-breakers should be used, in which the mechanism contains an instantaneous disconnection controlled by a bi-metal blade.

**Never protect a three-phase motor with fuses not equipped with a differential system:** if three phase motors are powered on 2 phases without a differential system, the motor could burn.

#### ◆ single-phase motor:

The table on the following page gives the characteristics at start-up (for temperatures  $\geq 12^{\circ}\text{C}$ ) and in permanent operation.

In this table, you will find, for each pump, a standard fuse or motor-associated value.

#### ◆ three-phase motor:

The table on the following page gives, for each pump, the electrical characteristics in permanent operation and the proposed circuit breaker.

## Single-phase motors

### Specific internal protection

Single-phase motors have a thermal circuit switch with automatic starting device (CSA standard): when the internal motor temperature reaches a value over the preset limit value, the motor stops. However, when the motor is cooled, it will start-up again automatically.

### Voltage range change

The voltage range can be read beside the motor switch: the dual frequency single-phase motor can be configured for low voltage (LV) or high voltage (HV).

To change this type of connection, proceed as follows:

- make sure that the motor is not switched on, and the power cord is removed,
- unfasten the 4 attachment screws on the motor upper cover and remove it,
- remove the voltage selector cover marked with the voltage, press on the voltage selector (position II).
- invert the position of the voltage selector cover in order to show the other voltage at the outside of the motor cover: "HV" for high voltages, or "LV" for low voltages. Check to be sure that the voltage selector has fully latched the rocket switch when the voltage selector cover is replaced.
- install the upper cover and refasten the 4 screws.
- secure the upper cover as follows:
  - Center it on the front motor flange,
  - Install the connector between the relay and condenser,
  - Close the upper cover,
  - Install and tighten the 4 screws, starting installing the screws on the pump handle side first.

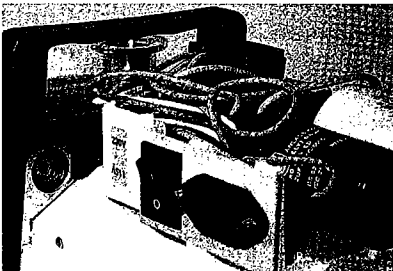

## Three-phase motors

### Electrical connections

The pumps are equipped with 9 wire terminal box motors, the wiring diagram of the terminals is given as a rough guide only. In the event of doubt, only the plate in the terminal box should be used as a reference.

### Terminal box (9 wires)

#### LOW VOLTAGE CONNECTION 220/240 V 50 Hz - 220/280 V 60 Hz Parallel coupling

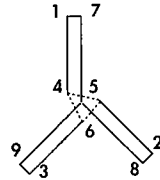
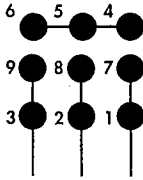

#### HIGH VOLTAGE CONNECTION 380/415 V 50 Hz - 380/480 V 60 Hz Serial coupling

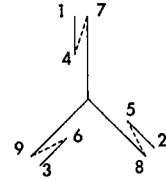
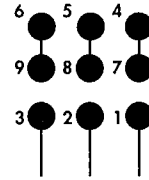

## Summary tables of various types of motors

The characteristics and ratings of fuses and circuit breaker associated with standard ALCATEL pump motors, 5 to 21 m<sup>3</sup>/h, single-phase or three-phase.

### Single-phase motor

Voltage/Frequency	Current at Ultimate Pressure (A)		*Start-up current (A)		Proposed Fuse protection (A)	
	50 Hz	60 Hz	50 Hz	60 Hz	Standard	Type aM**
100V 50/60Hz	5.0	3.5	30.0	34.0	20/20	8/6
115V 60Hz		4.0		35.0	20	6
200V 50/60Hz	2.5	2.0	14.0	19.0	10/16	4/4
220V 60Hz		2.0		20.0	16	4
230V 50Hz	3.5		8.0		10	4

\* Temperature = 12°C

\*\* aM : Motor-associated type fuse

### Three-phase motor

Voltage/Frequency	*Start-up current (A)		Proposed Circuit Breaker protection (A)	
	50 Hz	60 Hz	50Hz	60Hz
<b>Low voltage</b>				
200V 50/60Hz	3.1	2.8	4	3.5
220V 50/60Hz	3.5	3.1	4.5	4
240V 50Hz	4.0		5	
280V 60Hz		3.7		4.5
<b>High voltage</b>				
380V 50Hz	1.5		2	
415V 50Hz	1.6		2	
480V 60Hz		1.6		2

\* Temperature = 12°C



## Troubleshooting and corrective actions

Incidents	Causes	Corrective actions
The pump is not running	• Incorrect motor power supply.	Check the power supply.
	• Temperature too low.	Reheat the pump and its oil.
	• Gumming of seals after prolonged storage.	1 - Disassemble the motor and try to turn the fan manually. 2 - Disassemble, clean the pump, replace seals, reassemble.
	• Oil contaminated after pumping.	Drain, flush and refill with clean oil.
	• Motor coupling damaged. • Pump seized, due to a stopping after pumping in difficult conditions (no draining or flushing).	Replace by disassembling the motor. Disassemble, clean, hone the scratched metal parts (replace them if necessary) and reassemble.
The pump does not start	• Oil cold.	Warm pump.
	• Insufficient oil in the oil case.	Fill up to the level.
	• Oil contaminated.	Drain, flush and refill with clean oil.
	• Oil pump inlet partially blocked.	Drain, and clean the oil pump inlet duct.
	• Lubrication holes blocked.	Disassemble and clean.
	• Vane or spinner-cam (SD models) damaged.	Replace them.
	• Incorrect anti-suckback system assembly.	Repeat the assembly and the setting.
The vacuum pump does not produce a vacuum	<b>Ultimate pressure obtained: a few mbar, Torr</b>	
	• Direction of motor rotation incorrect (three phase).	Rewire.
	• Insufficient motor power.	Check the power supply.
	• Inlet filter blocked.	Clean it.
	• Insufficient oil in the oil case.	Add oil.
	• Oil cold, oil pump inlet blocked.	Warm, disassemble, clean.
	• Oil contaminated.	Drain, flush and start again with clean oil.
	• Oil pump inlet partially blocked.	Drain and clean the oil pump inlet duct.
	• One of the LP safety valves is damaged.	Replace.
	• Part forgotten in reassembly.	Repeat the reassembly.

## Maintenance

### General precautions

For normal operation, the maintenance of ALCATEL 5 to 21 m<sup>3</sup>/h series pumps only require regular oil changes.



Before any draining or maintenance operation, check the pumping conditions of the installation: potential toxicity, corrosion or radioactivity of pumped gases.

Depending on the case, we recommend:

- to purge the pumping installation with dry nitrogen before maintenance;
- wear gloves, protective goggles and, if necessary, a breathing apparatus;
- ventilate the premises well and disassemble the equipment under a suction hood;
- not to dispose of used oils and residues using the standard system and, if necessary, have them destroyed by a specialized company.



After a complete maintenance operation, it is recommended to perform a helium leak tightness test.



## Recovery of oil (high pressure and cycling)

When the pump operates at high pressure, the oil heats up, becomes more fluid and is flushed out of the functional block by the gas stream. Oil losses at the exhaust are increased.

### For intermittent pumping

If the pump only operates for a very short time at high pressure, the lubricating oil is replaced when the pump returns to low pressure. The use of an oil mist eliminator prevents losses due to intermittent high pressure operation.

### For cyclical pumping

If the pump operates at high pressure in a cyclical fashion, oil consumption may reach sufficiently high levels (according to the pumped volume and pumping cycle rates) causing the level to drop in the oil case. There is then a risk of seizure due to a lack of oil. In addition, the high flow of gas passing through the eliminator prevents oil from returning to the oil case.

In order to pump in these conditions, the pump must be equipped with an OME 25 HP type oil mist eliminator and an ODK oil draining kit, which enables oil recovery via the gas ballast.

#### Cyclical pumping: ODK type oil recovery device

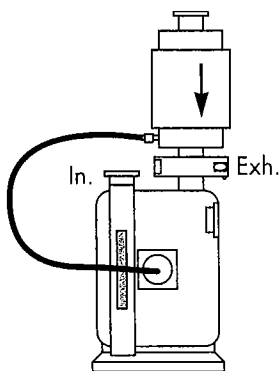

OME 25 HP + ODK 1



Device is not tight when switched off.

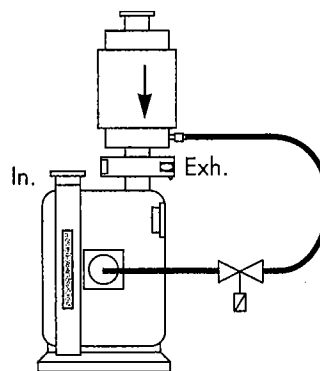

OME 25 HP + ODK 2

An electrovalve ensures tightness when switched off.

### For continuous pumping at high pressure

In this case, or when very large volumes (requiring several hours of pumping) are being pumped, it is recommended to recover the oil via the pump inlet. In this case, please consult Alcatel directly.

## Oxygen pumping

In certain applications, mixtures containing oxygen at different concentrations, or even pure oxygen, are used.

Oils of mineral origin are combustible. Exposure to pure oxygen at high temperatures may cause them to self-ignite. In addition, they are highly oxidized during pumping and quickly lose their lubricating properties. Mineral oils must not be used for oxygen levels of over 21 % in pumped gases. In this case, perfluorinated synthetic oils must be used, see list on **page 67**.

The use of these oils requires a special pump preparation (**see page 88**).

The pump must be completely disassembled and all traces oil mineral oil removed. Flushing the oil case is not adequate.



In addition, it is strongly recommended not to use fluids such as tri-aryl-phosphate-ester which are known to cause accidents.

Any accumulation of oxygen in the installation should be avoided and the oxygen or combustible mixture should be diluted with a neutral gas at the exhaust: the gas flow rate should be 4 times the oxygen flow rate.

**Certain combustible or explosive gases require a higher degree of dilution. Our International Support Services and Customer Services can advise you to help solve problems of this kind.**

**Settings (continued)** Run the pump at ultimate vacuum for one hour and set the nitrogen flow rate as follows (at atmospheric pressure and at 20°C).

C2 Series Pumps	Nitrogen flow rate in l/h			Corresponding absolute pressures (bar)
	Min	Average	Maxi	
	60	200	500	1.05 to 1.10

**Note:** these characteristics apply for pumps operating at a constant inlet pressure (1 to 5 mbar): they are adapted for each case of pumping.

**Start-up** Start-up the pump at ultimate vacuum. When it is hot, run the nitrogen purge. Use it from the beginning and throughout pumping.

**Stop** When pumping stops, allow the purge to operate for approximately 1 hour (depending on the quantity of pumped gas) at ultimate vacuum, with the purge, in order to degas the oil effectively and clean the pump with nitrogen to eliminate the traces of pumped gases.

# Purges for pumping condensable, corrosive, and hazardous gases

## All pumps models

**Purges** The use of vane pumps may result in pumping gases or vapours which are flammable or that could contaminate the oil. In this case, these products must be diluted using purges supplied with dry gases, such as nitrogen to avoid undesirable reactions.

For this purpose, a filtered dry nitrogen supply or other inert gas with the same characteristics is required:

- condensation point < 22°C,
- dust < 1µm,
- minimum absolute pressure 2 bar.

**Oil case purges** The purge dilutes pumped gases with a neutral gas: it makes it possible to limit corrosion in the oil case, condensation and accumulation of gases in dead spaces of the pump.

Connect the nitrogen supply to one of the unused filling plugs on the oil case (BSPP 1/8 Gas connection).

Set the nitrogen pressure to approximately 1,2 PSIG (0.1 relativ bar) (flow 50 to 300 SCCM) and the flow rate so as to satisfy the dilution conditions.

Caution: do not generate an excess pressure > 14 PSIG (1 relativ bar).

**Use of purge with gas ballast** A neutral gas supply can also be connected via the gas ballast (BSPP 1/8 Gas connection).

## C2 models

**Purge with gas ballast** Due to the danger represented by the accidental opening of the gas ballast on a C2 series pump, manual operation of the gas ballast has been disabled. However, it is possible to disassemble it and connect it directly to a neutral gas line (BSPP 1/8 Gas connection).

The nitrogen flow rate should be from 900 to 1000 l/h with a pressure of 1 to 1,2 PSIG (0.05 to 0.1 relativ bar).

**Use of the bubbler** The bubble device is composed of an air tube with several holes, located at the bottom of the oil case, which releases bubbles of neutral gas in the oil. In this way, the oil is saturated with neutral gas, which reduces its capacity to dissolve pumped gases. The bubbles of neutral gas released make it possible to eliminate the volatile vapours or acids condensed in the oil. The bubbler flow also lowers the pumps temperature which slows corrosion.

**Setting** The gas flow rate is adapted according to the application and the installation, taking the following criteria into account (flow 60 to 500 SCCM):

- When pumping high quantities of gas, a highly corrosive gas or an easily condensable gas, it is recommended to use a high nitrogen flow rate.

**Caution ! It is assumed that a sufficient quantity of nitrogen is available.**

- The pump exhaust circuit must be such that, for discharged flow rates, pressure drops do not cause an abnormal excess pressure in the oil case.
- The nitrogen flow rate must be such that oil losses have no effect on the operation of the pump throughout the pumping cycle (the oil level must be above the lower limit of the sight glass at the end of pumping).