

Chemtech Scientific provides access to this content as a courtesy.
We do not own the content contained in this document.
All rights and credit go directly to its rightful owners.
www.chemtechsci.com
Call us at: 484-424-9415



Instruction Manual

Diaphragm Pump Unit

DPS-901N (Stand Mount)

DPS-903N (Cart Mount)

DPS-904N (Wall Mount)

This instruction manual contains **IMPORTANT WARNINGS, CAUTIONS** and **INSTRUCTIONS**.
Read and understand this instruction manual before use and retain for reference.



Important Information – Safety Precautions

- Equipment in this instruction manual is exclusively for coating purposes. Do not use for other purposes.
- Read and understand this instruction manual. The operator shall fully understand the requirements stated within the instruction manual including important warnings, cautions, operation and correct handling.
- Incorrect operation or mishandling can cause serious bodily injury, death, fire or explosion.



Safety precautions

- The safety precautions in this instruction manual describe the minimum necessary information. Be sure to follow national and local regulations on fire prevention, electricity and safety as well as your own corporate regulations.
- Pay special attention to sections shown with the symbols below. The explanations of the symbols are as follows:

Warning and caution

 WARNING	This symbol indicates that a potentially hazardous situation may result in serious injury or death if not followed.
 CAUTION	This symbol indicates that a potentially hazardous situation may result in minor or moderate injury or damage to equipment if not followed.

Types of symbols

	This symbol indicates you must use caution. Explanation will be given near symbol.
	This symbol indicates warning may cause physical harm. Explanation will be given near symbol.
	This symbol indicates recommendations or requirements. Explanation will be given near symbol.

Notes

 IMPORTANT	This symbol indicates important information needed to achieve full performance and function of the equipment.
HINT	This symbol indicates useful knowledge and advice.

ANEST IWATA shall not be responsibility for any injury or damage caused by the disregard of warnings, cautions or the instructions contained in this instruction manual.

Important Information - Safety Precautions

1. Safety Warnings	2
2. Specifications	4
3. Functions	7
4. Setup	8
5. Operation	10
6. Cleaning	12
7. Maintenance	12
8. Trouble Shooting	13
9. Disassembly and Assembly	16
10. Parts List	25

1. Safety Warnings



WARNING

FIRE OR EXPLOSION HAZARD

1. Fluid and/or solvent can be highly flammable or combustible.
 - Use in well-ventilated spray booth.
 - Avoid any ignition sources such as smoking, open flames or electrical hazard.
2. To reduce the risk of static sparking, grounding continuity to the spray equipment, fluid container and object being sprayed must be maintained.



HAZARD CREATED WHILE COATING MATERIALS ARE ATOMIZED AND SPRAYED

1. Toxic vapors produced by spraying certain materials can cause intoxication and serious damage to health.
 - Use in well-ventilated areas.
 - Always wear protective clothing, eyewear, gloves and respirator to prevent toxic vapor, solvent and paint from coming into contact with your eyes and skin.



PRESSURIZED FLUID HAZARD – INJECTION HAZARD

1. Pressurized hazardous fluid can cause serious injury or death.
 - Always wear protective clothing, eyewear, gloves and respirator.
 - Never spray toward a person or animals and never pull the trigger of the spray gun near the body.
 - Never stop or deflect a fluid leak from the spray equipment or fluid hose with your hand. Be sure to stop the spray equipment according to the correct procedures.
2. Replace hoses immediately, if cracked, damaged, bent, crushed, distorted or worn. Use of such hoses can cause damage.
3. Never bend hoses with a radius of less than 2in. (50mm) or put heavy items on top of hoses.
4. Keep hoses away from sharp edge and moving parts.
5. Be sure to tighten all connections.



MISUSE HAZARD

1. Never touch moving parts.
2. Always release air and fluid pressure when not in use.
3. Always release air and fluid pressure before cleaning, disassembly or service. For emergency stop and to prevent unintended operation, a shut off valve is installed on this unit to stop the air supply.
4. Be sure to use the spray equipment at less than the maximum working pressure. If not, it can cause spray equipment failure, malfunction, serious injury or death.
5. Never modify this unit for any other applications.
6. Never use this unit to spray or supply food products.
7. If operation appears incorrect, immediately stop operation and find the cause.
8. Never use until the problem has been solved.
9. Pay attention to avoid hitting or dropping this unit, especially threaded and seated parts.
10. Never use damaged parts.
11. Repair or replace worn or damaged parts immediately. Always use ANEST IWATA replacement parts.
12. Never operate this unit or disassemble without receiving proper education and training.
13. Wear hearing protection.



OTHER HAZARD

1. Be sure to follow fire prevention, electrical and other local regulations.

CAUTION

1. Never use the following homogenate hydrocarbon solvents.
 - Methyl chloride
 - Dichloromethane
 - 1,2-dichloromethane
 - Carbon tetrachloride
 - Trichloroethylene
 - 1,1,1-trichloroethane
2. Be sure to use compatible fluids with the wetted parts of this unit and the spray gun, hoses and fittings. Make sure to review the Material Safety Data Sheet (MSDS) from paint or fluid manufacturer.

IMPORTANT

1. Check to ensure that this unit has not been damaged during transportation.
2. Install this unit in a dry, clean and well-ventilated area.
3. Use clean air filtered through a dryer and a filter finer than 50 microns. If not, it can cause spray equipment malfunction and finish problem.
4. Be sure to follow local guidelines for proper fluid storage procedures.
5. Be sure to follow local guidelines for proper cleaning and fluid disposal procedures.

2. Specifications

2-1. Specifications

2-1-1. Unit

Model		DPS-901N	DPS-903N	DPS-904N
Type		Stand Mount	Cart Mount	Wall Mount
Dimensions (L x W x H)	inch	21.0 x 20.9 x 40.3	19.7 x 20.9 x 40.3	11.2 x 12.4 x 23.1
	mm	533 x 530 x 1,023	500 x 530 x 1023	285 x 316 x 586
Weight (without hoses and gun)	lbs	35.3	39.7	28.7
	kg	16	18	13
Diaphragm Pump Model		DDP-90DN (Stainless Steel Model)		
Pressure Ratio		1:1		
Air Inlet		BSPP1/4" (G1/4")		
Air Outlet (to spray gun)		BSPP1/4" (G1/4")		
Fluid Inlet		BSPP1/2" (G1/2")		
Fluid Outlet		BSPP3/8" (G3/8")		
Maximum Inlet Air Pressure		98psi (0.68MPa, 6.8bar)		
Fluid Regulator Model		PR-5N (Stainless Steel Model)		
Maximum Fluid Working Pressure		85psi (0.59MPa, 5.9bar)		
Maximum Fluid Output		0.53gal/min (2.0L/min)		
Fluid Filter Set		100mesh		
Suction Filter		50mesh (Optional 100mesh)		
Maximum Fluid Viscosity		300cps (100sec/NK-2, 85sec/Ford#4, 24sec/Zahn#4)		
Wetted Parts		Stainless Steel, PTFE, POM		
Operating Ambient Temperature		41 - 104°F (5 - 40°C)		
Operating Air/Fluid Temperature		41 - 109°F (5 - 43°C)		
Noise Level		71.7 dB(A) Measuring point: 1.0m backwards and 1.6m height from pump		
Required compressor (for pump)		1/2 - 2.0hp		

2-1-2. Pump Only

Diaphragm Pump Model	DDP-90DN (Stainless Steel Model)
Pressure Ratio	1:1
Maximum Inlet Air Pressure	98psi (0.68MPa, 6.8bar)
Maximum Fluid Working Pressure	98psi (0.68MPa, 6.8bar)
Maximum Fluid Output	2.64gal/min (10.0L/min)
Maximum Cycle	200cycles/min
Maximum Fluid Output per cycle	1.70oz/cycle (50ml/cycle)

*See spray gun instruction manual about specifications of spray gun.

2-2. Performance Curve

DDP-90DN pump only

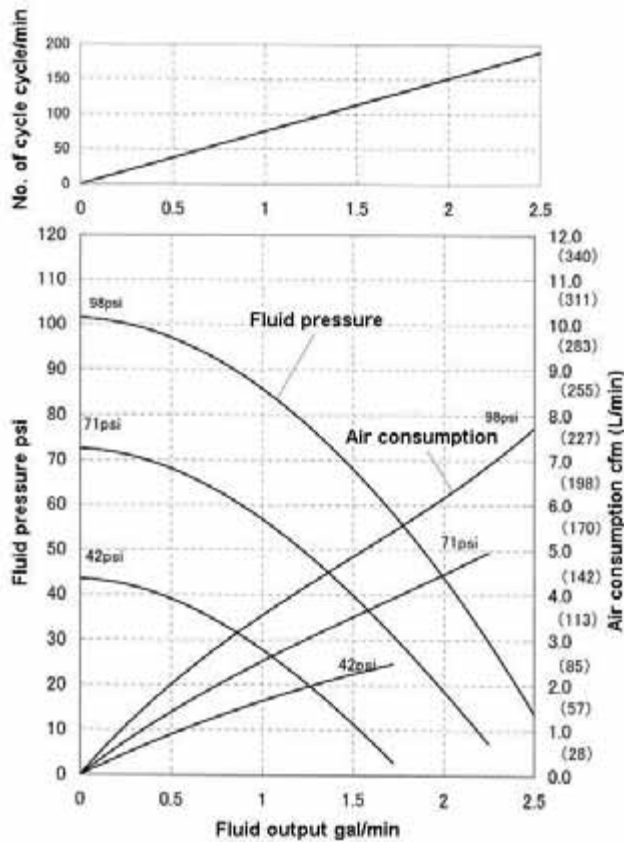

Inlet air pressure: The number with each curve
Test fluid: Water

How to find fluid pressure

1. Locate specific fluid output along the horizontal axis of the chart.
2. Follow vertical to the intersection with the fluid pressure curve of selected inlet air pressure.
3. Follow left to the vertical axis of the chart to read fluid pressure.

How to find air consumption

1. Locate specific fluid out put along the horizontal axis of the chart.
2. Follow vertical to the intersection with the air consumption curve of selected inlet air pressure.
3. Follow right to the vertical axis of the chart to read air consumption.

How to find cycle per minutes

1. Locate specific fluid output along the horizontal axis of the chart.
2. Follow vertical to the intersection with number of cycle curve of top chart.
3. Follow left to the vertical axis of the chart to read cycle per minutes.

Example: See example to right Fig. A

When inlet air pressure is 71psi and fluid output is 1.0gal/min,

1. Fluid pressure is approx. 57psi
2. Air consumption is approx. 3.5cfm.
3. Cycle per minutes is approx. 60cycles/min.

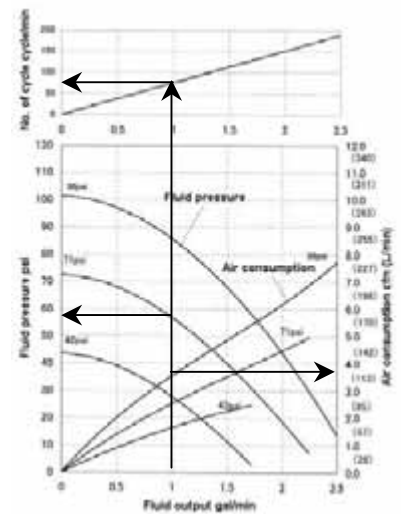
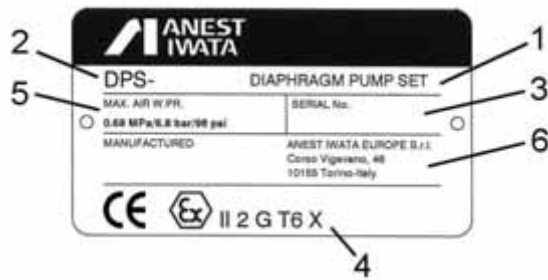

Fig. A

2. Specifications

2-3. Model plate



Ref	Description
1	Model name
2	Model
3	Serial Number
4	CE-EX Marking
	<ul style="list-style-type: none"> - Equipment group: II - Category: Gas2G - Area: Gas - Maximum surface temperature: temperature class T6 - X marking <p>Any static electricity discharge from the spray gun is to be diverted to the grounded the conductive air hose as stipulated.</p>
5	Maximum air working pressure
6	Manufacturer

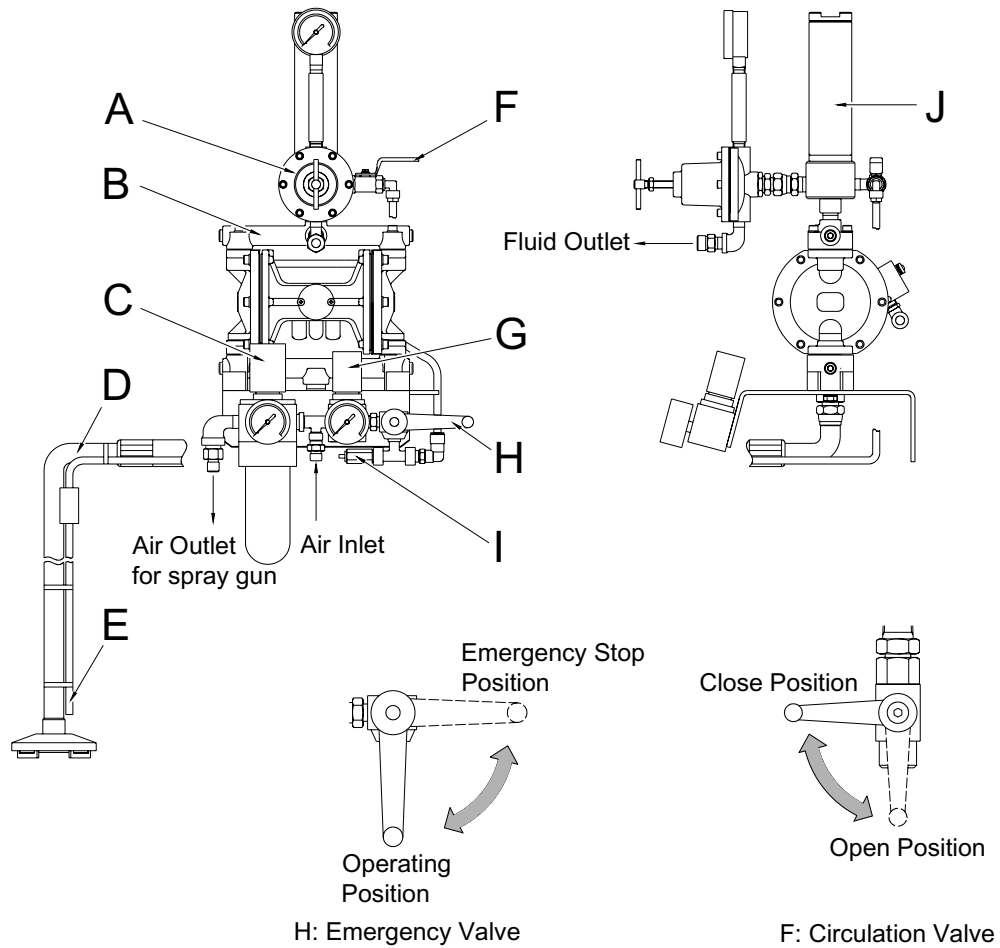

Fig.1: Functions

	Parts	Function
A	Fluid Regulator	PR-5N, Stainless steel model. To adjust fluid pressure
B	Diaphragm Paint Pump	DDP-90DN, Stainless steel model
C	Air Filter Regulator	For atomizing air. w/locking knob feature
D	Suction Hose Set	with 50mesh filter
E	Circulation Tube	To circulate or dump fluid
F	Circulation Valve	To circulate or dump fluid
G	Air Regulator	For pump operation. w/locking knob feature
H	Emergency Valve	Emergency air shut off valve
I	Pop-off Valve	Working pressure: 116psi
J	Fluid Filter Set	100mesh

*Spray gun and fluid and air hoses are not included in this unit.

4. Setup

4-1. Wall mount unit installation

⚠ CAUTION

1. Be careful not to drop this unit during installation.
2. Install this unit on stable wall able to support the weight of this unit, hoses, any accessories and material inside the pump and stress created by pump operation.

Wall mount hole layout

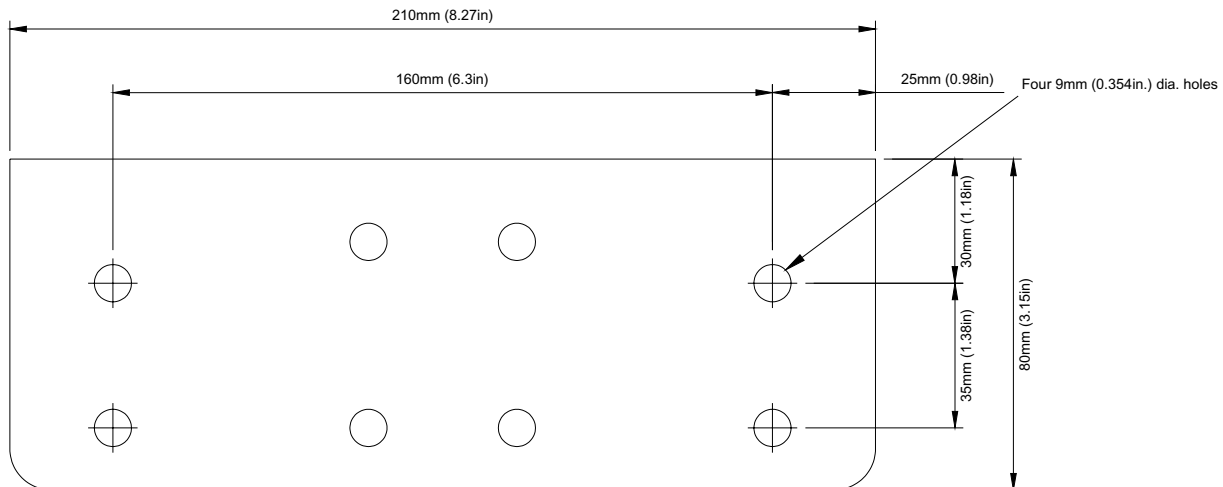

4-2. Setup

⚠ WARNING

1. This unit should be operated by adequately trained operators only.
2. To reduce the risk of static sparking, grounding continuity to the spray equipment, fluid container and object being sprayed must be maintained.
3. Be sure to tighten all connections.
4. Be sure to follow fire prevention, electrical and other local regulations.



⚠ IMPORTANT

1. Install this unit in a dry, clean and well-ventilated area.
2. Use clean air filtered through a dryer and a filter finer than 50 microns. If not, it can cause spray equipment malfunction and finish problem.

HINT

1. Grounded air hose designed by ANEST IWATA is available.

Refer to **Fig.1** on page 7 to find reference letters.

1. Place this unit on hard level surface and load uniformly, if stand or cart mount unit.
2. Secure ground wire.
3. Close **Fluid Regulator** (A) and **Air Regulators** (C and G) fully.
4. Set **Emergency Valve** (H) to “**Emergency Stop**” position and open **Circulation Valve** (F).
5. Connect fluid and air hoses to the outlet fittings of this unit and other end to inlet fittings of spray gun. If hoses or fittings are damaged, replace immediately.
6. Connect air supply hose to inlet of unit.

4-3. Checking operation**⚠ WARNING**

1. Never touch moving parts.

**⚠ IMPORTANT**

1. Do not keep pump idling for extended periods of time. Prolonged idle operation may cause premature pump failure.

HINT

1. Press reset button of air operating valve behind the pump if pump does not operate.

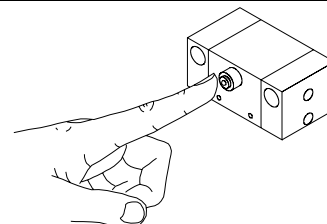

Refer to **Fig.1** on page 7 to find reference letters.

1. Check **Fluid Filter Set (J)** and suction filter installed on **Suction Hose Set (D)**. If they are clogged, clean or replace.
2. Close **Fluid Regulator (A)** and **Air Regulators (C and G)** fully.
3. Open **Circulation Valve (F)**.
4. Set **Emergency Valve (H)** to “**Operating**” position.
5. Turn on the air supply to the unit.
6. Remove **Suction Hose Set (D)** from the pump fluid inlet and adjust **Air Regulator (G)** to 22 - 73psi (0.15 - 0.5MPa, 1.5 - 5bar) slowly.
7. After pump is running, cover fluid inlet fitting underneath the pump with your palm and feel for suction to make sure that pump is working. If not, see **8. Trouble Shooting** on page 13.
8. Set **Emergency Valve (H)** to “**Emergency Stop**” position to make sure that pump operation stops.
9. Close **Air Regulators (C and G)** fully.
10. Connect **Suction Hose Set (D)** and **Circulation Tube (E)**. If they are clogged or damaged, clean or replace.

5. Operation

WARNING

1. Use in well-ventilated spray booth.
2. Avoid any ignition sources such as smoking, open flames or electrical hazard.
3. Always wear protective clothing, eyewear, gloves and respirator.
4. Never spray toward a person or animals and never pull the trigger of the spray gun near the body.
5. Never stop or deflect a fluid leak from the spray equipment or fluid hose with your hand. Be sure to stop the spray equipment according to **5-4. Emergency stopping** procedure on page 11.
6. Never touch moving parts.
7. Always release air and fluid pressure when not the use.
8. Always release air and fluid pressure before cleaning, disassembly or service. For emergency stop and to prevent unintended operation, a shut off valve is installed on this unit to stop the air supply.
9. Be sure to use the spray equipment at less than the maximum working pressure. If not, it can cause spray equipment failure, malfunction, serious injury or death.
10. Never modify this unit for any other applications.
11. Never use this unit to spray or supply food products.
12. If operation appears incorrect, immediately stop operation and find the cause. See **8. Trouble Shooting** on page 13.
13. Never use until the problem has been solved.



CAUTION

1. Be sure to use compatible fluid and cleaning fluid with the wetted parts of this unit.

5-1. Flushing

IMPORTANT

1. Flush fluid passages of this unit completely with cleaning fluid before first use and every time after use. If not, it can cause finish problem and pump malfunction.
2. Always fully close or fully open circulation valve. Opening valve halfway can cause seat wear, fluid leakage and lack of fluid pressure.
3. Be sure to follow local guidelines for proper cleaning and fluid disposal procedures.

Refer to **Fig.1** on page 7 to find reference letters.

1. Close **Fluid Regulator** (A) and **Air Regulators** (C and G) fully.
2. Open **Circulation Valve** (F).
3. Set **Emergency Valve** (H) to “**Operating**” position.
4. Put **Suction Hose Set** (D) and **Circulation Tube** (E) into cleaning fluid container.
5. Adjust **Air Regulator** (G) to 22 - 73psi (0.15 - 0.5MPa, 1.5 - 5bar) slowly.
6. Circulate cleaning fluid or dump to another container through **Circulation Tube** (E).
7. Point spray gun toward to container and pull the trigger of the spray gun. Be sure that compressed air is not supplied to the spray gun before pulling the trigger.
8. Close **Circulation Valve** (F) and adjust **Fluid Regulator** (A) slowly.
9. Circulate cleaning fluid or dump to another container through the spray gun.
10. After flushing, lift **Suction Hose Set** (D) from container and keep operating pump until air comes out of spray gun.
11. Open **Circulation Valve** (F) and release the trigger of the spray gun.
12. Keep operating until air comes out from **Circulation Tube** (E).
13. Close **Fluid Regulator** (A) and **Air Regulators** (C and G) fully.

5-2. Preparing for spraying

IMPORTANT

1. Never block exhaust holes on the front and backside of air operating valve. It can cause pump malfunction.
2. Always fully close or fully open the circulation valve. Opening the valve halfway can cause seat wear, fluid leakage and lack of fluid pressure.

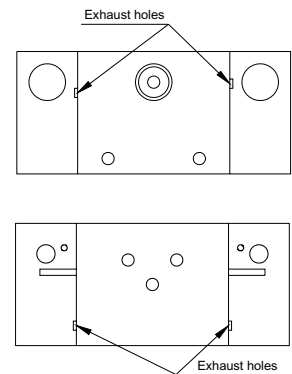

HINT

1. Press reset button of air operating valve behind pump if pump does not operate.

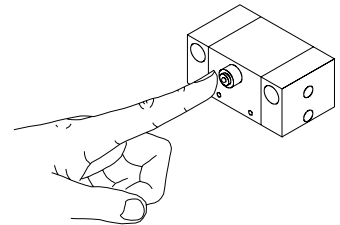

Refer to **Fig.1** on page 7 to find reference letters.

1. Close **Fluid Regulator** (A) and **Air Regulators** (C and G) fully.
2. Open **Circulation Valve** (F).
3. Set **Emergency Valve** (H) to “**Operating**” position.
4. Put **Suction Hose Set** (D) and **Circulation Tube** (E) into fluid container.
5. Adjust **Air Regulator** (G) to 22 - 73psi (0.15 - 0.5MPa, 1.5 - 5bar) slowly.
6. Circulate fluid **Circulation Tube** (E) until fluid does not contain bubbles.
7. Point spray gun toward to container and pull the trigger of the spray gun. Be sure that compressed air is not supplied to the spray gun before pulling the trigger.
8. Close **Circulation Valve** (F) and adjust **Fluid Regulator** (A) slowly.
9. Circulate fluid from spray gun until fluid does not contain bubbles.
10. Release the trigger of the spray gun.

5-3. Spraying

IMPORTANT

1. See spray gun instruction manual for spray gun operation.

Refer to **Fig.1** on page 7 to find reference letters.

1. Adjust **Fluid Regulator** (A) and **Air Regulators** (C and G) to specified pressure.
2. Start spraying.

5-4. Emergency stop

Refer to **Fig.1** on page 7 to find reference letters.

1. Set **Emergency Valve** (H) to “**Emergency Stop**” position and open **Circulation Valve** (F).

5. Operation

5-5. Stopping operation

Refer to **Fig.1** on page 7 to find reference letters.

1. Close **Fluid Regulator** (A) and **Air Regulators** (C and G) fully.
2. Open **Circulation Valve** (F) slowly and pull the trigger of the spray gun. Make sure fluid and air pressure are at "0".

6. Cleaning

WARNING

1. Use in well-ventilated spray booth.
2. Avoid any ignition sources such as smoking, open flames or electrical hazard.
3. Always wear protective clothing, eyewear, gloves and respirator.
4. Never spray toward a person or animals and never pull the trigger of the spray gun near the body.
5. Never stop or deflect a fluid leak from the spray equipment or fluid hose with your hand. Be sure to stop the spray equipment according to **5-4. Emergency stopping** procedure on page 11.



CAUTION

1. Be sure to use compatible cleaning fluid with the wetted parts of this unit.

IMPORTANT

1. Flush fluid passage of this unit completely with cleaning fluid every time after use. If not, it can cause finish trouble and pump malfunction.
2. Always fully close or fully open the circulation valve. Opening the valve halfway can cause seat wear, fluid leakage and lack of fluid pressure.
3. Be sure to follow local guidelines for proper cleaning and fluid disposal procedures.

Refer to **Fig.1** on page 7 to find reference letters.

1. Clean fluid passage of pump and spray gun. (Refer to **5-1. Flushing** procedure on page 10)
2. Clean **Fluid Filter Set** (J) and suction filter is installed on **Suction Hose Set** (D). Replace if necessary.

7. Maintenance

Daily	<ol style="list-style-type: none"> 1. Clean fluid passage of pump and spray gun and fluid filters. 2. Check for worn, damaged or broken parts. 3. Drain water from air regulator, if necessary.
Every 50 hours	<ol style="list-style-type: none"> 1. Clean fluid passage of pump and filters, if fluid contains lots of pigments and pump is run continuously.
Every 100 hours	<ol style="list-style-type: none"> 1. Clean fluid passage of pump and filters, if pump is run continuously.
Every 2,000 hours	<ol style="list-style-type: none"> 1. Overhaul. 2. Replace parts with repair service kit. The parts included in the repair service kit are shown in 10. Parts List on page 26 and 27. 3. Replace any other worn or damaged parts if necessary.

8. Trouble Shooting

Refer to **Fig.1** on page 7 and **10. Parts List** on page 25 - 30 to find reference letters and numbers.

No.	Problems	Causes	Remedies
1	Pump does not operate.	Air pressure is not supplied to the unit.	Check air compressor and hoses. Check emergency valve.
		Air operating valve does not operate.	Push reset button of air operating valve. *1
		Packings inside air operating valve are worn or damaged.	Replace packing with repair service kit. *2
		Exhaust holes of air operating valve are blocked.	Clean. *3
		Pump operating air pressure is too low.	Increase supplied air pressure.
			Increase air pressure at Air Regulator (G) .
		Diaphragm Set (2-5) of pump is worn or damaged.	Replace. *4
		Pump frozen (supplied air contains too much moisture).	Eliminate air moisture by using a dryer or water trap.
		Ball (2-3) sticks on intake or exhaust valve.	Clean. *4
Packing on rod of pump is worn or damaged or Y-shaped Packing (2-13) is installed in the incorrect direction.	Replace. *5		
2	Pump operation unstable. Fluid output is low. Fluid does not come out during pump operation.	Pump operating air pressure is too low.	Increase supplied air pressure.
			Increase pump operating air pressure at Air Regulator (G) .
		Fluid Filter (5-4) or Suction Filter (6-5) are clogged.	Clean or replace.
		Suction Hose Set (E) is clogged.	Clean or replace.
		Exhaust holes of air operating valve are blocked.	Clean. *3
		Pump frozen (supplied air contains too much moisture).	Eliminate air moisture by using a dryer or water trap.
		Intake Valve (2-12) or Exhaust Valve (2-2) are worn or damaged or paint is built up.	Clean or replace. *4
		Ball (2-3) sticks on intake or exhaust valve.	Clean. *4
		O-ring (2-14) or Y-shape Packing (2-13) on Rod of pump or oilless bearing are worn or damaged.	Replace. *4
		Diaphragm set (2-5) of pump is damaged.	Replace. *4
		Fluid or air passage inside pump is clogged.	Clean.
		Diaphragm (3-12) of fluid regulator is worn or damaged.	Replace. *4
		Seat (3-5) of fluid regulator is worn or damaged or paint is built up.	Clean or replace. *4
Fluid contains air.	See below No.3 .		

8. Trouble Shooting

No.	Problems	Causes	Remedies
3	Paint contains air.	Air has not been released.	Refer to 5-2. Preparing spraying on page 11.
		Suction Hose Set (D) or fluid inlet joint of pump are loose.	Tighten.
		Lower Adaptor (2-24) is loose.	Tighten Bolts (2-15) . *6
		Diaphragm Set (2-5) is damaged.	Replace. *4
		Nut (2-7) is loose.	Tighten. *3
		O-ring (2-9) is worn or damaged.	Replace. *3
		Fluid contains air by over agitating.	
4	Pulsation or variance within spray pattern.	Fluid pressure is too low.	Increase fluid pressure at Fluid Regulator (A) or Air regulator (G) .
		Fluid Filter (5-4) or Suction Filter (6-5) are clogged.	Clean or replace.
		Intake Valve (2-12) or Exhaust Valve (2-2) is worn or damaged or paint is built up.	Clean and replace. *4
		Exhaust hole of air operating valve is blocked.	Clean. *3
		Fluid or air is leaking.	Find leak and fix.
5	Paint leaks from fluid hose or joint.	Fluid hose or joint is loose or damaged.	Tighten or replace.
		Paint builds up on seat of fluid joint.	Clean or replace.
	Paint leaks from between Upper Adaptor (2-16) or Lower Adaptor (2-24) and Pump Body (2-21) .	Adaptor is loose.	Tighten Bolts (2-15) . *6
		Seat Packing (2-1) of pump is worn or damaged	Replace. *4
	Paint leaks from between Cover (2-22) and Pump Body (2-21) .	Cover (2-22) is loose.	Tighten Bolts (2-23) . *6
		Diaphragm Set (2-5) of pump is damaged.	Replace. *4
	Paint leaks from Fluid Filter Set (J) .	Cylinder (5-1) is loose.	Tighten.
		Packing (5-5 and 5-6) is worn or damaged.	Replace.
	Paint leaks from Fluid Regulator (A) .	Diaphragm Cap (3-19) is loose.	Tighten Bolts (3-17) . *7
		Joint (3-1) is loose or damaged or paint is built up on seat of joint.	Tighten, replace or clean.
		Diaphragm (3-12) is worn or damaged.	Replace. *4
		O-ring (3-4) is worn or damaged.	Replace. *4

8. Trouble Shooting

No.	Problems	Causes	Remedies
6	Air leaks from air hose or joint.	Air hose or fitting is loose or damaged.	Tighten or replace.
	Air leaks from Air Operating Valve (2-17).	Air Operating Valve (2-17) is not installed stably.	Tighten Bolts (2-18). *3
		Packing inside air operating valve is damaged.	Replace packing with repair service kit. *2
		Air operating valve itself is damaged.	Replace. *4
	Air leaks from between Cover (2-22) and Pump Body (2-21).	Cover (2-22) is loose.	Tighten Bolts (2-23) *3
		Diaphragm Set (2-5) of pump is damaged.	Replace. *4
	Air leaks from air regulator.	Air regulator is damaged.	Replace.
		Air regulator is installed in the incorrect direction.	Reinstall.

*1 Refer to **4-3. Checking operation** on page 9.

*2 Refer to **10-7. Air operating valve** on page 30.

*3 Refer to **d) Air operating valve** on page 22.

*4 Refer to **9. Disassembly and Assembly** on page 16.

*5 Refer to **b) Rod** on page 20.

*6 Refer to **e) Upper and lower adaptor and covers** on page 22.

*7 Refer to **d) Diaphragm cap** on page 24.

9. Disassembly and Assembly

WARNING

1. Always release air and fluid pressures before cleaning, disassembly or service.
2. Pay attention to avoid hitting or dropping this unit, especially threaded and seated parts.
3. Never use damaged parts.
4. Repair or replace worn or damaged parts immediately. Always use **ANEST IWATA** replacement parts.
5. Never modify this unit for any other applications.
6. Do not disassemble or assemble without receiving proper education and training.

IMPORTANT

1. Clean fluid passage of pump before disassembly.

9-1. Disassembly

9-1-1. Pump

a) Upper and lower adaptors and covers

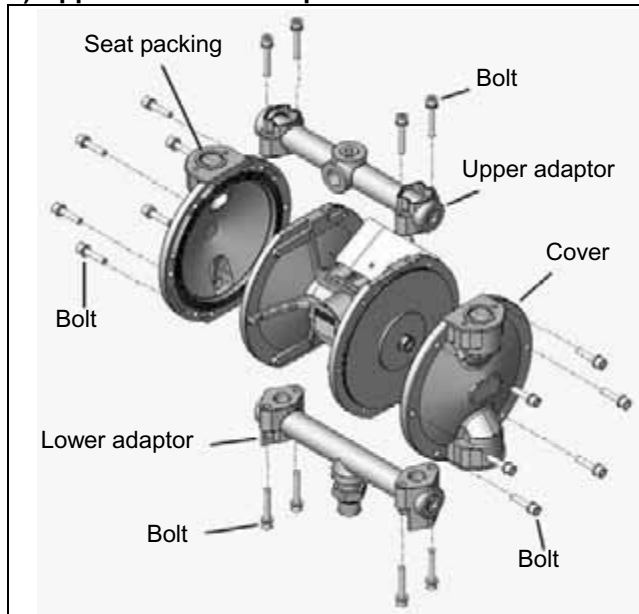

Use a 5mm allen wrench.

1. Loosen the four bolts and remove upper adaptor.
2. Loosen the four bolts and remove lower adaptor.
3. Remove the four seat packings.
4. Loosen the six bolts and remove cover each side.

b) Air operating valve

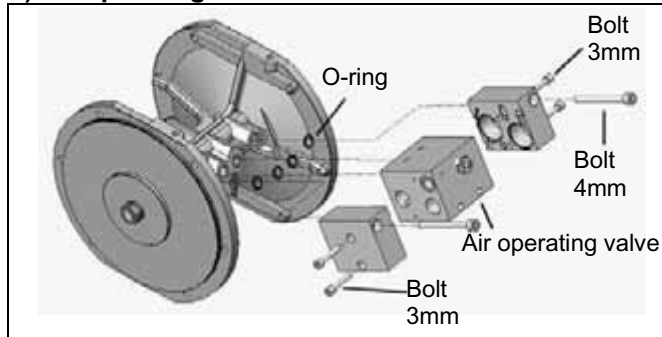

1. Loosen the two bolts with a 4mm allen wrench.
2. Remove the air operating valve and the four o-rings from pump body.
3. Loosen the four bolts with a 3mm allen wrench and remove the side blocks.
4. Removing the inside parts of the air operating valve, refer to **10-7. Air operating valve** on page 30.

9. Disassembly and Assembly

c) Diaphragm set

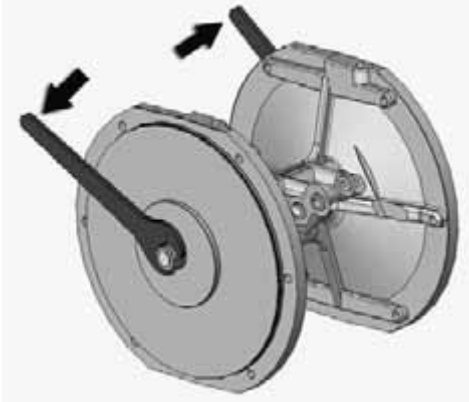
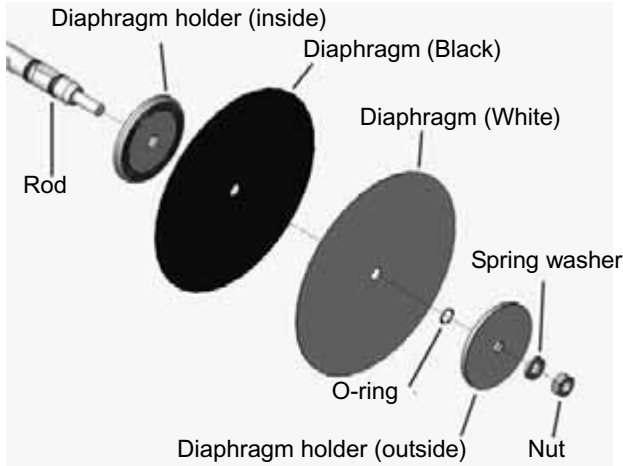
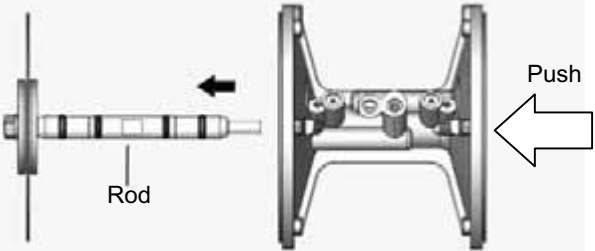
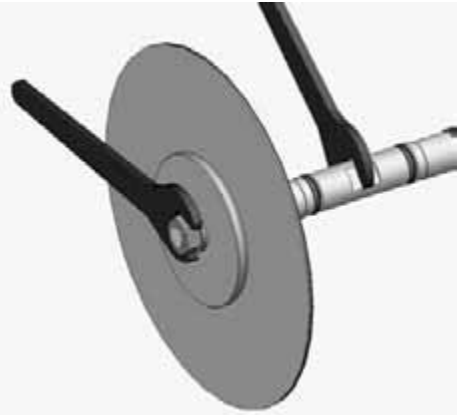
	<ol style="list-style-type: none">1. Loosen the two nuts with a 13mm wrench.
	<ol style="list-style-type: none">2. Remove the following parts from rod.<ul style="list-style-type: none">- Nut- Spring washer- Diaphragm holder (outside)- O-ring- Diaphragm set (White: outside, Black: inside)- Diaphragm holder (inside)
	<ol style="list-style-type: none">3. Push the rod through the opposite side of the pump.
	<ol style="list-style-type: none">4. Hold flat face of center of the rod with a 12mm wrench, and loosen the nut with a 13mm wrench.5. Remove the following parts from the rod.<ul style="list-style-type: none">- Nut- Spring washer- Diaphragm holder (outside)- O-ring- Diaphragm set (White: outside, Black: inside)- Diaphragm holder (inside)

9. Disassembly and Assembly

d) Rod

IMPORTANT

1. Do not damage or bend rod and be sure to check that the rod is free of foreign matter. It can cause pump failure.

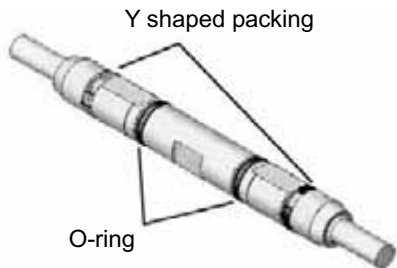

1. Remove the two Y shaped packings and the two o-rings from rod.

e) Intake and exhaust valve

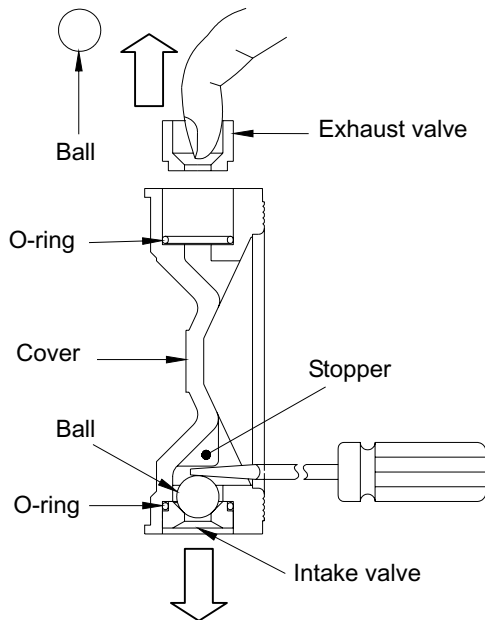

1. Press down the ball with a screwdriver by using stopper of the cover to remove the intake valve and the ball.
2. Remove the o-ring. Do not use any metal tool to avoid scratching the pump.
3. Remove the ball on the exhaust valve and pull the exhaust valve up with finger.
4. Remove the o-ring. Do not use any metal tool to avoid scratching the pump.

9. Disassembly and Assembly

9-1-2. Fluid regulator

a) Diaphragm cap

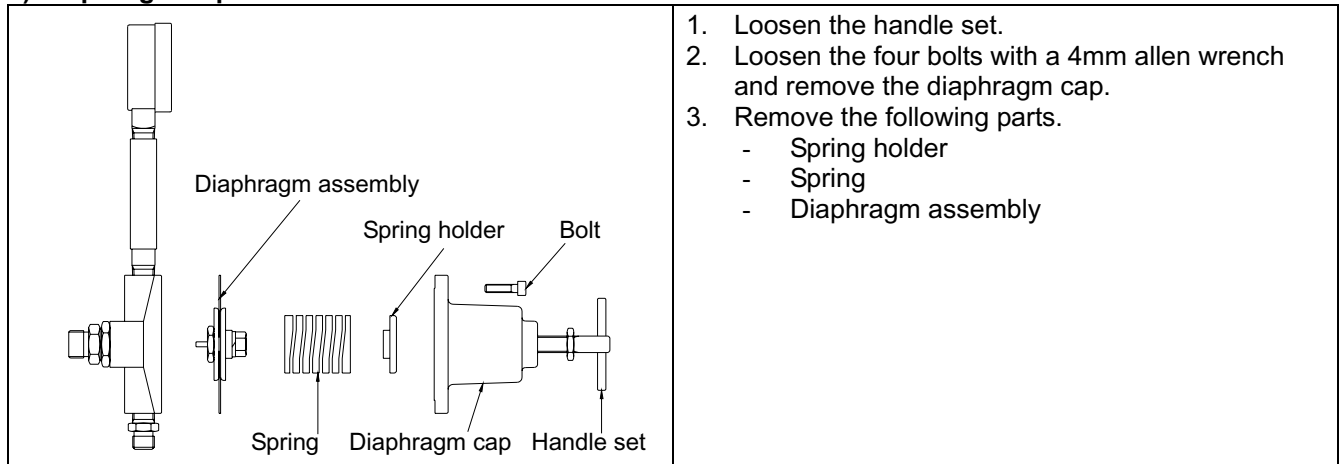

1. Loosen the handle set.
2. Loosen the four bolts with a 4mm allen wrench and remove the diaphragm cap.
3. Remove the following parts.
 - Spring holder
 - Spring
 - Diaphragm assembly

b) Diaphragm assembly

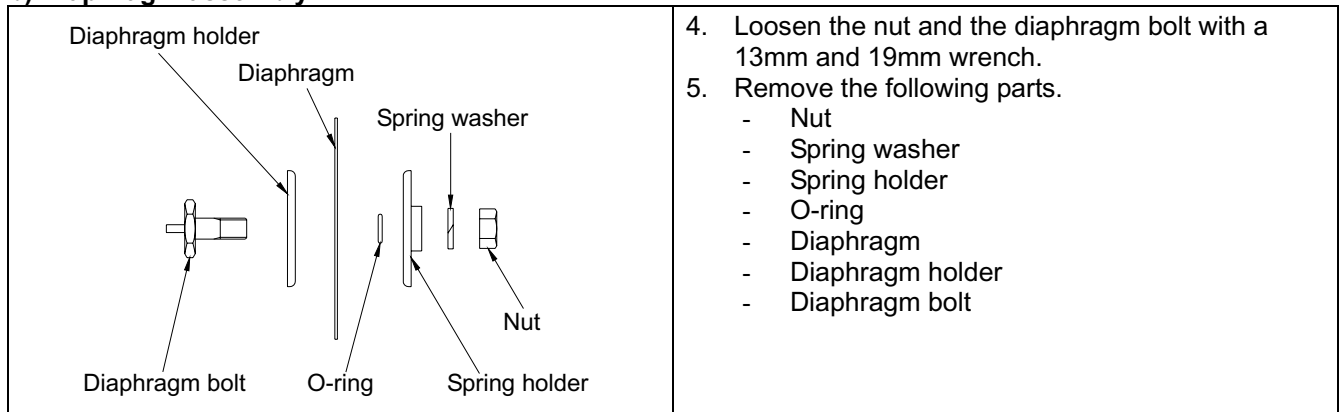

4. Loosen the nut and the diaphragm bolt with a 13mm and 19mm wrench.
5. Remove the following parts.
 - Nut
 - Spring washer
 - Spring holder
 - O-ring
 - Diaphragm
 - Diaphragm holder
 - Diaphragm bolt

c) Ball seat

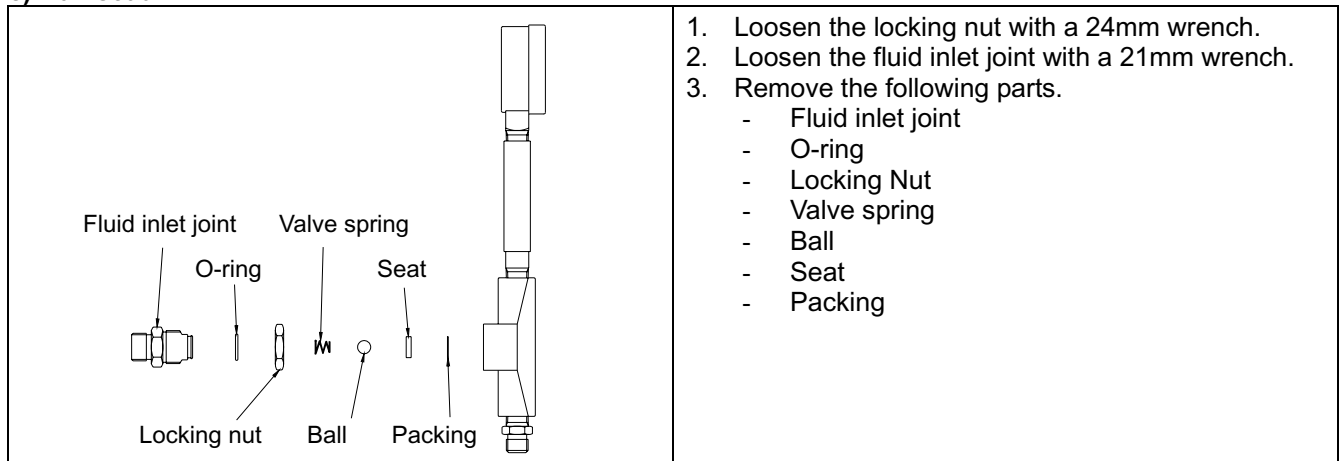

1. Loosen the locking nut with a 24mm wrench.
2. Loosen the fluid inlet joint with a 21mm wrench.
3. Remove the following parts.
 - Fluid inlet joint
 - O-ring
 - Locking Nut
 - Valve spring
 - Ball
 - Seat
 - Packing

9. Disassembly and Assembly

9-2. Assembly

9-2-1. Pump

a) Intake and exhaust valve

⚠ IMPORTANT

1. Be sure to set o-ring in valve. If not, it can cause fluid leakage.

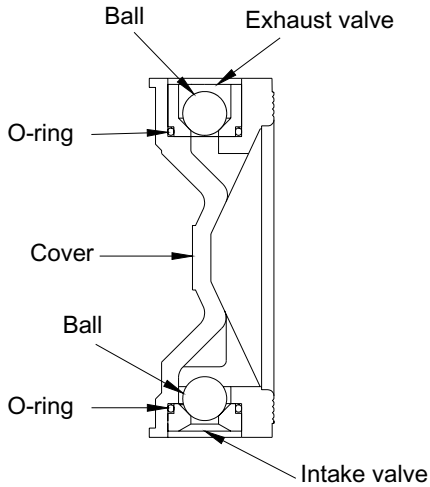

1. Place the o-ring, exhaust valve and ball into the cover.
2. Place the o-ring, ball and intake valve into the cover.

b) Rod

⚠ IMPORTANT

1. Be sure to set Y shaped packing and o-ring correct in the direction. If not, it can cause pump failure.
2. Always replace Y shaped packings and o-rings as set.

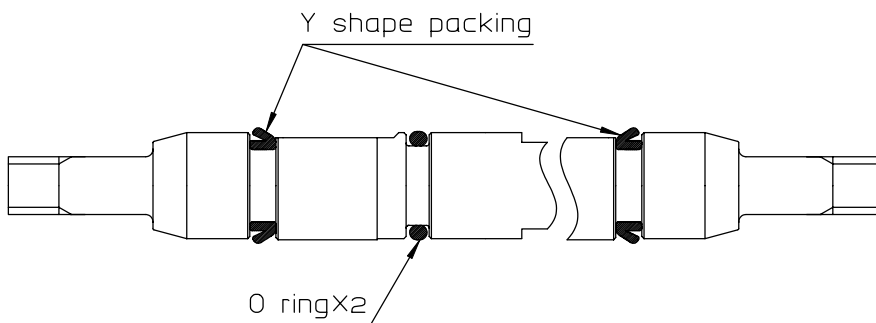

1. Place the two Y shaped packings and two o-rings to the rod.

9. Disassembly and Assembly

c) Diaphragm set

IMPORTANT

1. Put general-purpose grease on Y shaped packing and o-ring that are installed on rod.

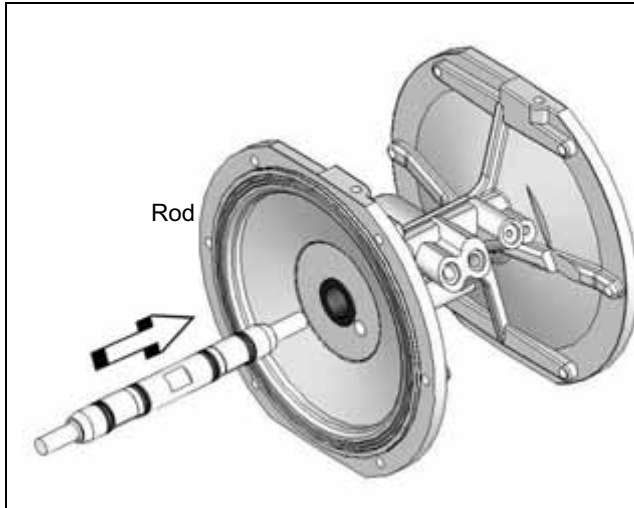

1. Insert the rod into the pump body.

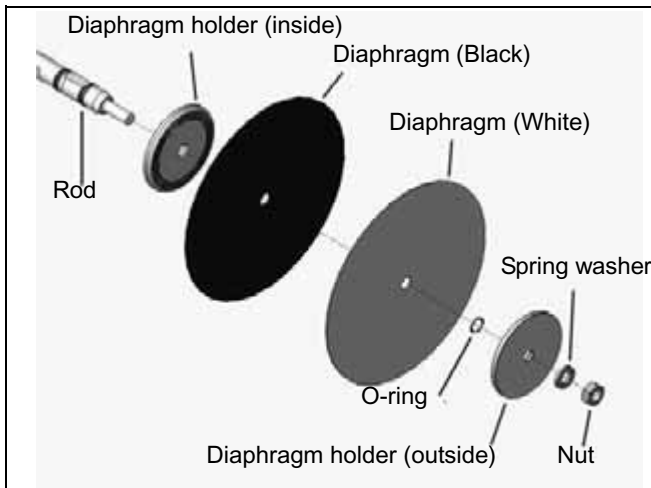

3. Place the following parts on the rod both sides of the pump.

- Diaphragm holder (inside)
- Diaphragm set (White: outside, Black: inside)
- O-ring
- Diaphragm holder (outside)
- Spring washer
- Nut

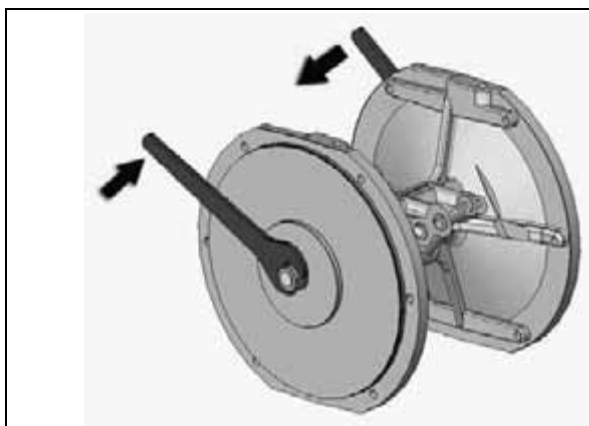

4. Tighten nuts with a 13mm wrench to 13in-lb (1470N·m, 150kgf·cm).

9. Disassembly and Assembly

d) Air operating valve

⚠ IMPORTANT

1. Do not block exhaust holes on front and backsides of air operating valve and inside of side blocks.
2. Blocking these holes can cause pump malfunction.

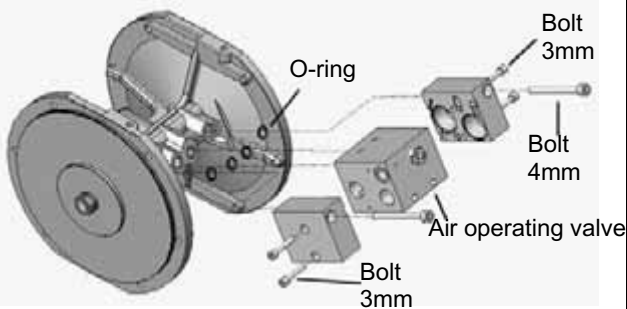
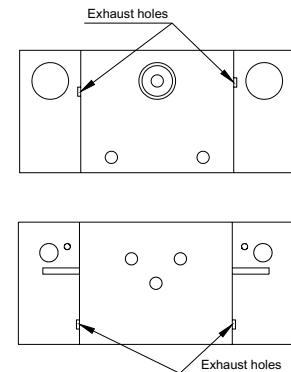
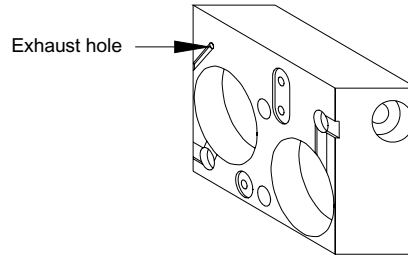

1. Place the parts inside. Refer to **10-7. Air operating valve** on page 30.
2. Place the two side blocks on the main block and tighten the two bolts with a 3mm allen wrench.
3. Place the four o-rings on the pump body.
4. Place the air operating valve on the pump body and tighten the bolts with a 4mm allen wrench.

e) Upper and lower adaptor and covers

⚠ IMPORTANT

1. Be sure that "UP" marking on pump body shows on top.

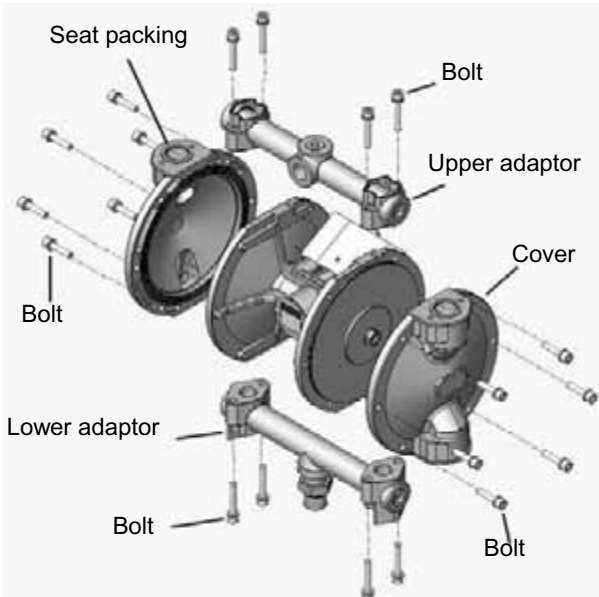

Use a 5mm allen wrench.

1. Place the cover on the pump body and loosely tighten the six bolts. Repeat on the other cover.
2. Put the four seat packings on the cover.
3. Put the lower adaptor to the pump body and loosely tighten the four bolts.
4. Put the upper adaptor on the pump body and loosely tighten four bolts.
5. Tighten all bolts evenly to 6.6in-lb (735N·m, 75kgf·cm).

9. Disassembly and Assembly

9-2-2. Fluid regulator

IMPORTANT

1. Place seat of flat side to main regulator body. Ball must be set on tapered side of the seat.
2. Never over-tighten fluid inlet joint. It can cause damage of regulator body.
3. Be sure not to damage diaphragm set when tightening bolts.

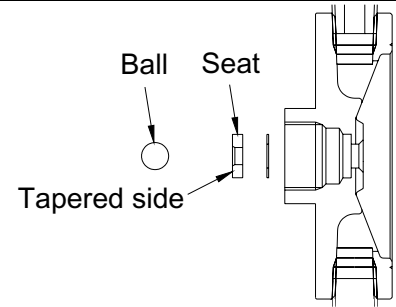

a) Diaphragm assembly

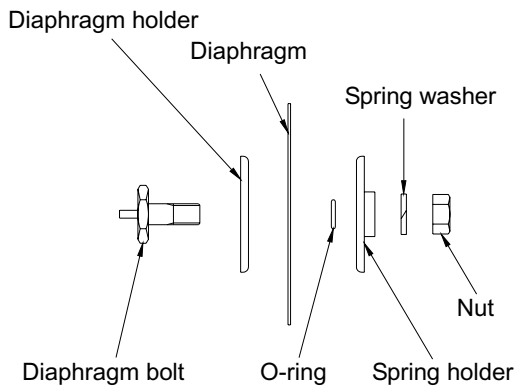

1. Place the diaphragm holder and the diaphragm on the diaphragm bolt. Fillet machined side of the diaphragm holder and plastic clear side of the diaphragm set must be placed face to face.
2. Place the o-ring and the diaphragm stopper to black rubber side of the diaphragm.
3. Place the spring washer and the nut on the diaphragm bolt and tighten to 8.7in-lb (9.8N·m, 100kgf·cm) with a 13mm and 19mm wrench.

b) Ball seat

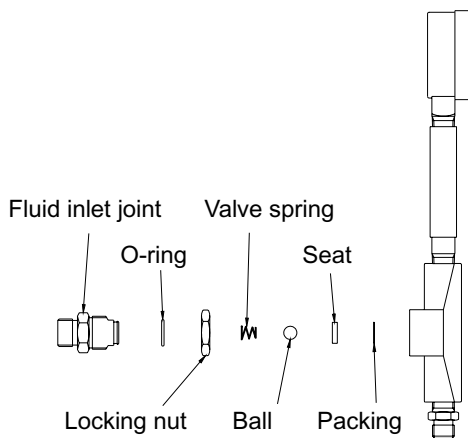

1. Hand tighten the locking nut and place the o-ring on the fluid inlet joint.
2. Place the packing, seat, ball valve spring and fluid inlet joint into the regulator body.
3. Tighten fluid inlet joint to 13in-lb (14.7N m, 150kgf cm) with a 21mm wrench.
4. Tighten rocking nut with a 24mm wrench.

9. Disassembly and Assembly

c) Diaphragm cap

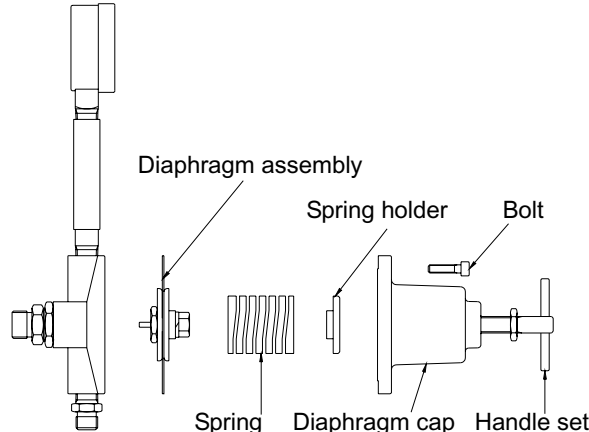
	<ol style="list-style-type: none">1. Place the following parts into regulator body.<ul style="list-style-type: none">- Spring holder- Spring- Diaphragm assembly2. Place the diaphragm cap and tighten the four bolts with a 4mm allen wrench evenly to 6.6in-lb (735N·m, 75kgf·cm).3. Insert handle set.
---	---

IMPORTANT

1. After disassembly and assembly for cleaning, maintenance or service, run the pump to be sure that pump operates collect according to **4-3. Checking operation** procedure on page 9.

10-1. Unit

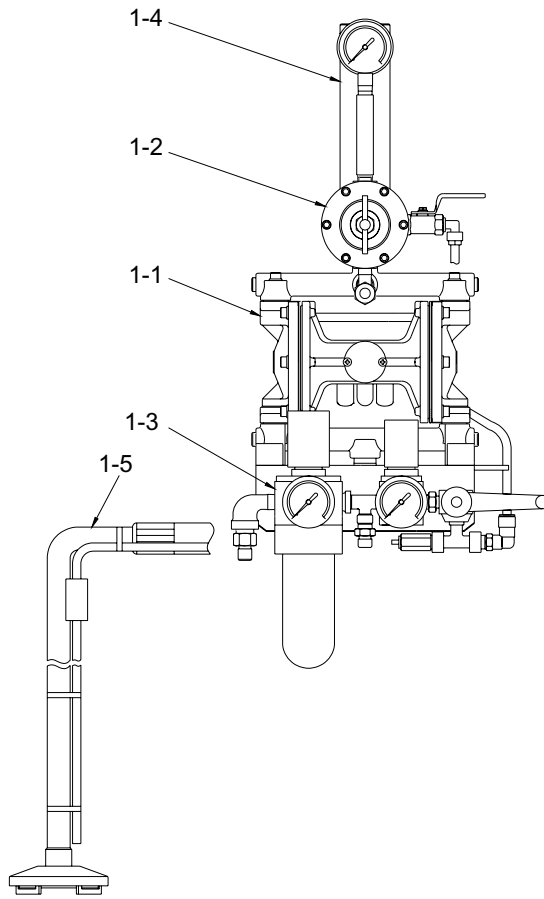

DPS-904N (Wall Mount)

No	Description	Qty
1-1	Diaphragm Pump	1
1-2	Fluid Regulator	1
1-3	Air regulator Set	1
1-4	Fluid Filter Set	1
1-5	Suction Hose Set	1
1-6	Stand Frame Set	1
1-7	Cart Frame Set	1

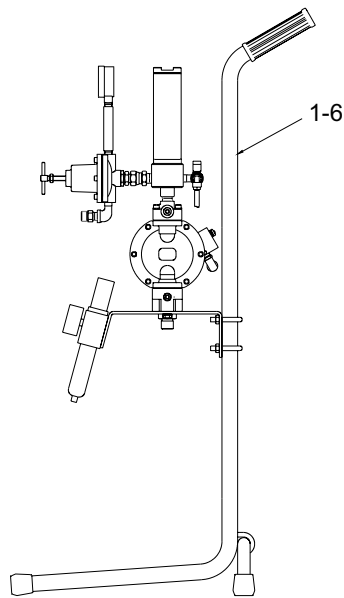

DPS-901N (Stand Mount)

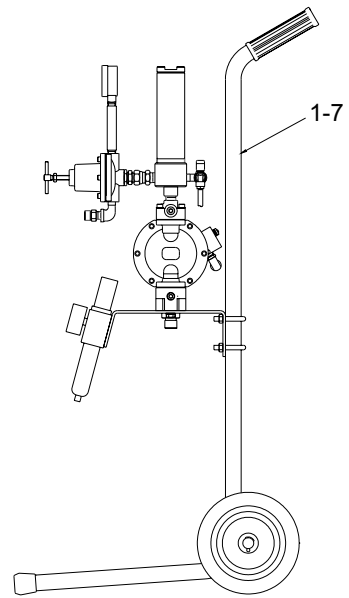

DPS-903N (Cart Mount)

10. Parts List

10-2. Diaphragm pump, DDP-90DN

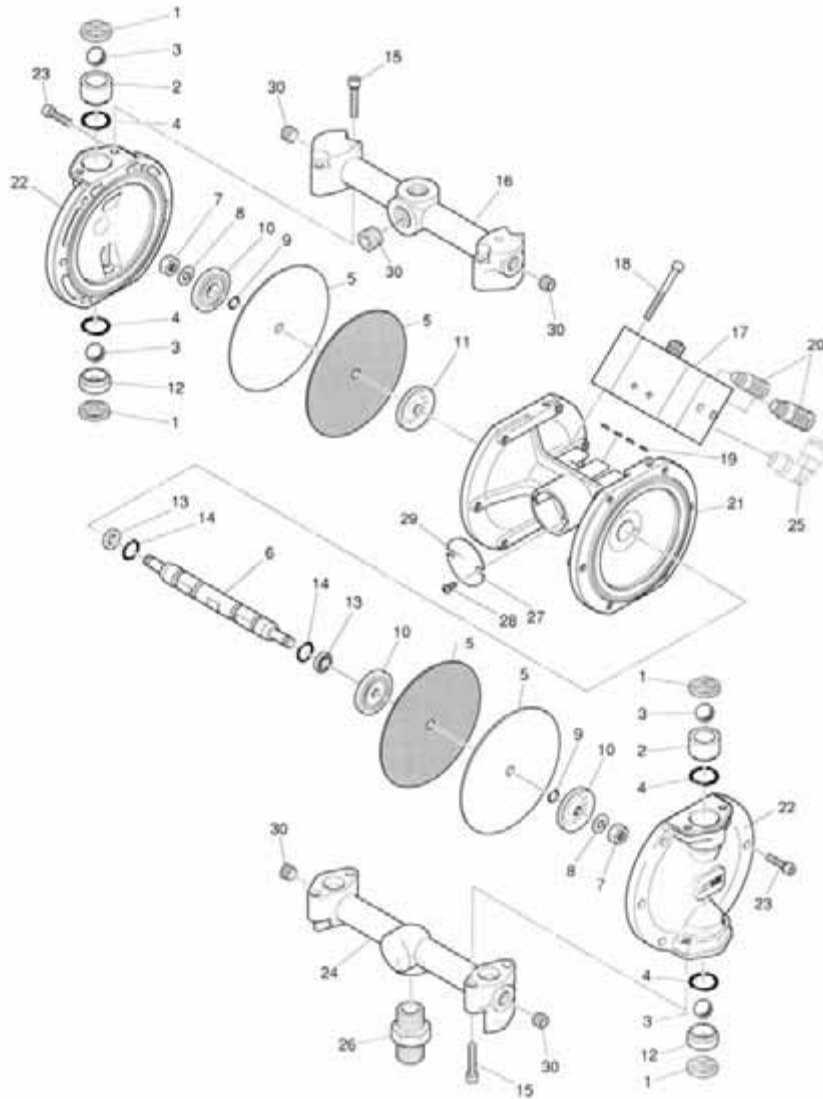

No	Description	Qty
■ 2-1	Seat packing	4
■ 2-2	Exhaust valve	2
■ 2-3	Ball	4
■ 2-4	O-ring	4
■ 2-5	Diaphragm set	2
2-6	Rod	1
2-7	Nut	2
2-8	Spring washer	2
■ 2-9	O-ring	2
2-10	Diaphragm holder-out	2
2-11	Diaphragm holder-in	2
■ 2-12	Intake valve	2
■ 2-13	Y packing	2
■ 2-14	O-ring	2
2-15	Bolt	8

No	Description	Qty
2-16	Adaptor upper	1
2-17	Air operating valve	1
2-18	Bolt	2
2-19	O-ring	4
2-20	Muffler	2
2-21	Main body	1
2-22	Cover	2
2-23	Bolt	12
2-24	Adaptor lower	1
2-25	Push-in elbow	1
2-26	Fluid inlet joint	1
2-27	Main body cover	1
2-28	Screw	2
2-29	Model plate	1
2-30	Plug	5

*Repair service kit of diaphragm pump includes "■" marked parts.

10-3. Fluid regulator, PR-5N

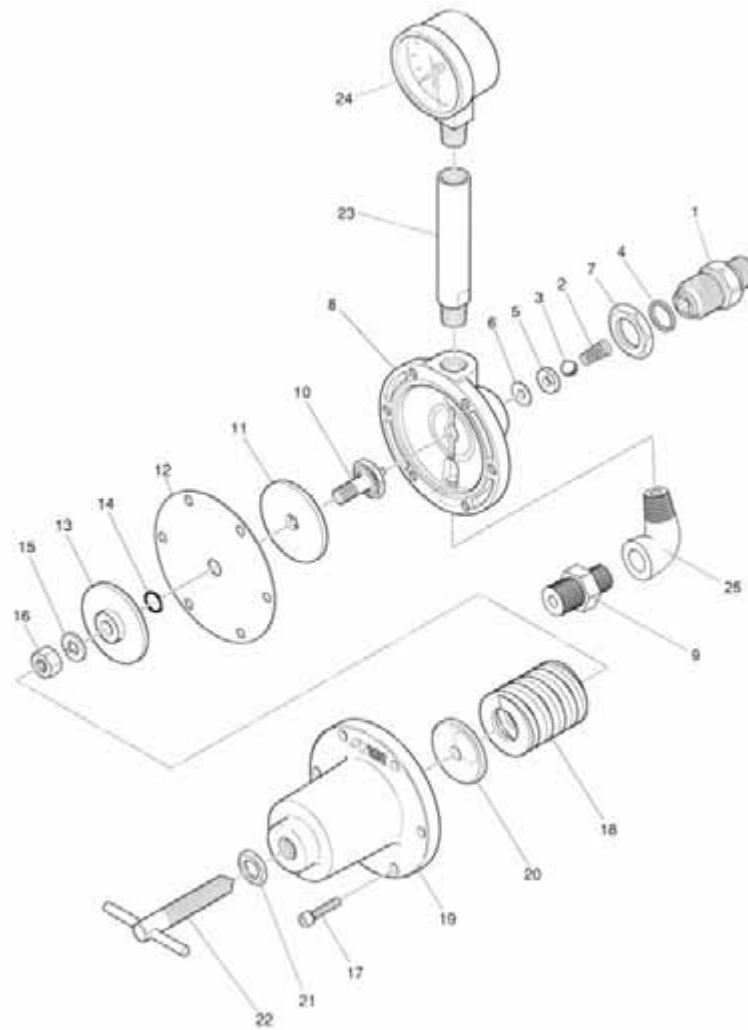

No	Description	Qty
3-1	Fluid inlet joint	1
3-2	Valve spring	1
3-3	Ball	1
3-4	O-ring	1
3-5	Seat	1
3-6	Packing	1
3-7	Locking nut	1
3-8	Regulator body	1
3-9	Fluid outlet joint	1
3-10	Diaphragm bolt	1
3-11	Diaphragm holder	1
3-12	Diaphragm	1
3-13	Spring holder	1

No	Description	Qty
3-14	O-ring	1
3-15	Spring washer	1
3-16	Nut	1
3-17	Bolt	6
3-18	Spring	1
3-19	Diaphragm cap	1
3-20	Spring holder	1
3-21	Nut	1
3-22	Handle set	1
3-23	Pipe	1
3-24	Pressure gauge	1
3-25	Elbow joint	1

*Repair service kit of fluid regulator includes “■” marked parts.

10. Parts List

10-4. Pump base set

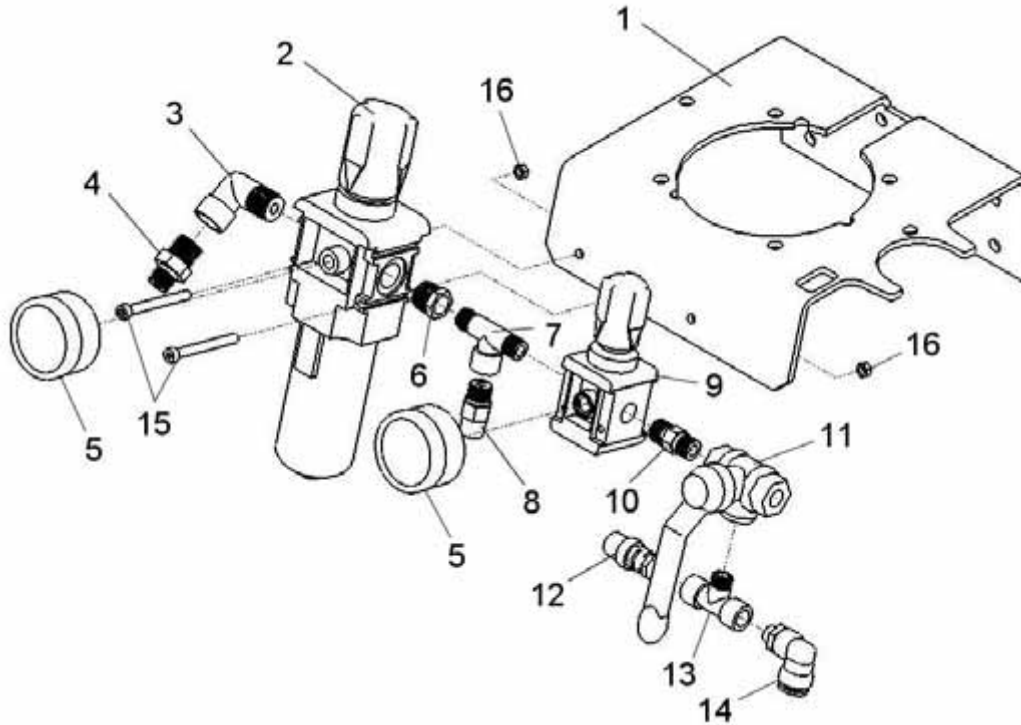

No	Description	Qty
4-1	Pump base	1
4-2	Air filter regulator	1
4-3	Elbow joint	1
4-4	Air outlet joint	1
4-5	Pressure gauge	2
4-6	Reducer	1
4-7	Tee joint	1
4-8	Air inlet joint	1

No	Description	Qty
4-9	Air regulator	1
4-10	Nipple	1
4-11	3-way ball valve	1
4-12	Pop-off valve	1
4-13	Tee joint	1
4-14	Push-in elbow	1
4-15	Bolt	2
4-16	Nut	2

10-5. Fluid filter set

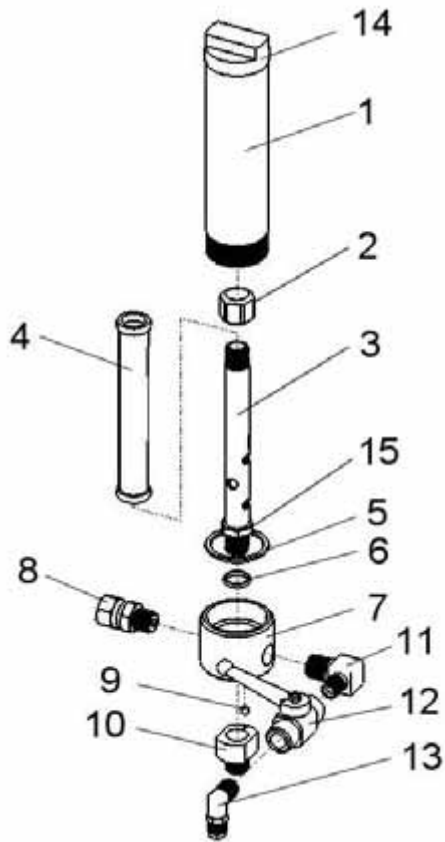

No.	Description	Qty
5-1	Cylinder	1
5-2	Cap nut	1
5-3	Filter bolt	1
5-4	Filter 100 mesh	1
5-5	Packing	1
5-6	Packing	1
5-7	Filter body	1
5-8	Swivel joint	1
5-9	Spring pin	1
5-10	Filter adaptor	1
5-11	Elbow joint	1
5-12	2-way ball valve	1
5-13	Elbow hose joint	1
5-14	Filter plug	1
5-15	Locking nut	1

10. Parts List

10-6. Suction hose set

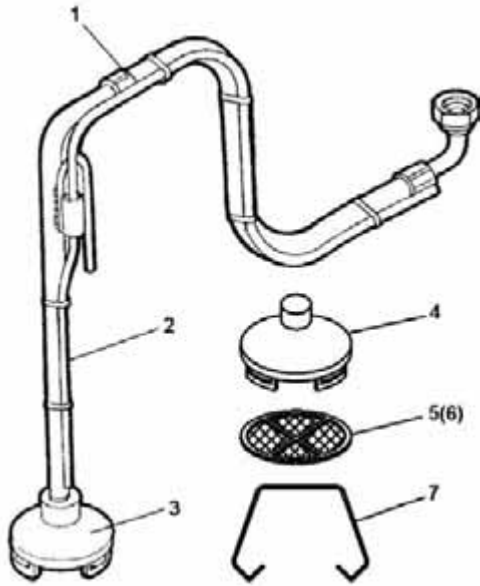

No.	Description	Qty
6-1	Suction Hose Set	1
6-2	Circulation Tube	1
6-3	Filter Set	1
6-4	Filter Cover	1
6-5	Filter 50mesh	1
6-6	Filter 100mesh (Option)	1
6-7	Filter Spring	1

10-7. Air operating valve (Repair service kit)

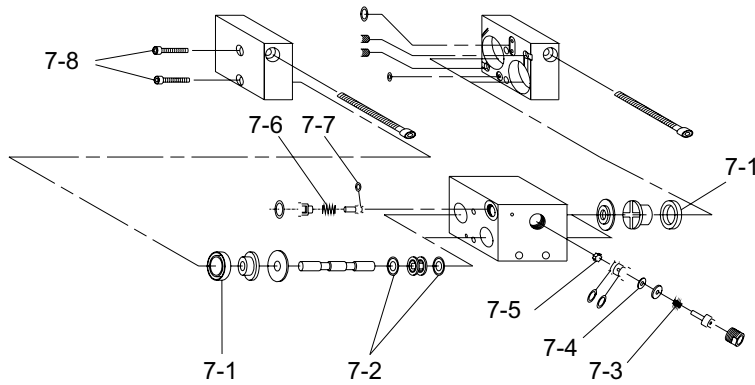

No.	Description	Qty
7-1	Piston Packing	4
7-2	Spool Packing	12
7-3	Reset Valve Spring (1)	1
7-4	Reset Valve Packing	1
7-5	Reset Valve	1
7-6	Reset Valve Spring (2)	1
7-7	O-ring	1
7-8	Bolt	4