

Chemtech Scientific provides access to this content as a courtesy.
We do not own the content contained in this document.
All rights and credit go directly to its rightful owners.
www.chemtechsci.com
Call us at: 484-424-9415



MAINTENANCE AND REPAIR MANUAL

R 5 Series
Models 0160, 0250, 0400, 0502, 0630 B Series
Single Stage Rotary Vane Vacuum Pumps

TABLE OF CONTENTS

	Page		Page
GENERAL	2	5.0 CLEANING PROCEDURE	9
Identification	2	6.0 PREPARATION FOR ASSEMBLY	9
1.0 INSTALLATION	2	6.1 Endplate Preparation	9
1.1 Oil Filling	2	6.2 Exhaust Box Preparation	9
2.0 OPERATION	2	7.0 ASSEMBLY	9
2.1 Start-up	2	7.1 Exhaust Valves	9
2.2 Oil Level Float Valve (newer models)	3	7.2 Bearings, Bearing Sleeves, Shaft Seals	10
2.3 Gas Ballast	3	7.3 Pump Module for Regular Overhaul	11
2.4 Water-Cooled Pumps (optional)	3	7.4 Pump Assembly	14
2.5 Oxygen Service Pumps	3	8.0 CHANGING FROM RA TO RC MODEL	15
3.0 ROUTINE MAINTENANCE	4	8.1 Differences Between RA and RC Pumps	15
3.1 Pump Oil	4	9.0 OIL LEVEL SWITCH INSTALLATION	15
3.1.1 Oil Level	4	10.0 TROUBLESHOOTING	16
3.1.2 Oil Type and Quantity	4	11.0 LIMITED STANDARD WARRANTY	20
3.1.3 Oil and Filter Change	4	Technical Data and Clearances Chart	21
3.1.4 Oil Flushing Procedure	5	Illustration of R 5 0160 Vacuum Pump	22
3.2 Automotive-Type Oil Filter	5	Parts List for R 5 0160	23
3.3 Exhaust Filter	6	Illustration of R 5 0400 Vacuum Pump	24
3.4 Vacuum Inlet Filter	6	Parts List for R 5 0400	25
3.5 Routine Maintenance Schedule	6	Illustration of R 5 0502/0630 Vacuum Pump	26
3.6 Overhaul Kit/Filter	7	Parts List for R 5 0502/0630	27
4.0 DISASSEMBLY	7	Busch Factory Service Centers	29
4.1 Necessary Tools	7		
4.2 Complete Disassembly	7		
4.3 Disassembly of Pump Module	8		

We reserve the right to change the product at any time without any form of notification. The information in this publication is accurate to the best of our ability at the time of printing. Busch, Inc. will not be responsible for errors encountered when attempting to perform tasks outlined in this publication which is copyright protected.

GENERAL

Identification

For model identification, see the nameplate mounted on the side of the exhaust box.

This manual is written to cover RA and RC versions of models 0160, 0250, 0400, 0502 and 0630 with a "B" appearing as the seventh character in the model type number stamped into the nameplate. For example, it would appear as follows:

RAXXXX-BXXX-XXXX

When ordering parts, it is helpful to include the identification code stamped into the side of the cylinder as well as the serial number from the nameplate.

All reference (Ref. XXX) numbers listed in the text and on illustrations throughout this manual are related to the drawings and parts list shown later in this publication.

This manual is designed to help optimize pump performance and reduce downtime through proper maintenance. Instructions are given for complete disassembly and assembly.

A separate Installation and Operation manual is provided with each new pump from the factory. Refer to it for general operation and installation guidelines. Please contact the factory if an additional copy is needed.

1.0 INSTALLATION

1.1 Oil Filling

WARNING: Do not use hydrocarbon oils in pumps on oxygen service. See Section 2.5 - Oxygen Service Pumps.

WARNING: Keep the oil fill plug tight as pressure in the exhaust box could cause bodily injury if the plug is blown out. Do not fill/add the pump with oil through the exhaust/inlet ports as there is danger of breaking the vanes!

The pump is shipped without oil. After level installation, and after correct rotation has been established, fill the pump with the recommended vacuum oil through the oil filling port (Ref. 88), observing the "MAX" and "MIN" position at the oil sight glass (Ref. 83). On pumps with two sight glasses, fill the top glass up to the 3/4 mark. Non-detergent oil should be used. Do not use detergent motor oil as additives in detergent oil will plug exhaust filter elements and shorten their life.

It is recommended that Busch R500 Series oil be used to receive the best performance from your vacuum equipment. R500 Series oil is a high quality vacuum oil that will give longer running time between oil changes, will provide better lubrication at high operating temperatures, and will prolong the life of exhaust filter elements. This oil can be obtained directly from Busch, Inc. in Virginia Beach, Virginia.

The strict use of Busch oils and parts from the day of purchase can extend the Limited Standard Warranty to three years. Contact Busch, Inc. in Virginia Beach, Virginia for details.

For general applications, use R530 in all models covered by this manual. Use R590 or R570 in pumps that are operated in high ambient temperatures (above 90°F) or high operating pressure when the oil carbonizes (turns black) before the change interval. Contact the factory for recommendations when using other oils.

The TECHNICAL DATA chart on page 21 gives the approximate quantities of oil required for each pump. The oil capacity chart should only be used as a guide, since oil capacity may be slightly lower, depending on whether the pump was filled previously, and whether all components such as oil filter, oil lines, etc., were allowed to completely drain. Use only the sight glass reading for proper level. Never overfill!

Replace the oil fill plug (Ref. 88), making sure that the gasket (Ref. 89) is in place and properly seated and secured. Some pumps are equipped with an exhaust pressure gauge as an integral part of the oil fill plug.

2.0 OPERATION

2.1 Start-up

Check rotation of the motor to insure it is rotating in the correct direction.

Fill the pump with oil as described in Section 1.1 - Oil Filling.

Start the pump and immediately close the inlet. Run the pump for a few minutes before checking the oil level again. With the pump shut off, the oil level should be visible in the oil sight glass (Ref. 83), between the "MIN" and "MAX" mark.

On pumps with two sight glasses, with the pump shut off, the oil level should be visible in the upper oil sight glass, between the "MIN" and "MAX" mark.

Add oil, if necessary, but only add it when the pump has been shut off and the circulating oil has had sufficient time to return to the oil sump.

On R 5 (Standard) RC model pumps, the collected oil is drawn continuously during operation of the vacuum pump to the inlet flange (Ref. 260) via the oil return line (Ref. 290). The oil return line is connected directly to the area of the exhaust box, downstream of the exhaust filter, which is at atmospheric pressure. RC model pumps can run continuously without having to shut them off for the oil to drain back.

2.2 Oil Level Float Valve (newer models)

Older models of the RA 0160, 0250, 0400 and 0630 had to be shut off every 8 hours of operation to allow oil to drain back to the oil sump via an oil check valve. Newer model RA 0400, RA 0502 and 0630 pumps have a float valve mechanism (Ref. 585) added to the outside of the exhaust box where the two oil return valves are located. This mechanism contains a float valve housed in a steel box that is mounted to the exhaust box. An oil return line runs from the steel box to the inlet of the pump. As the oil drips off of the exhaust filters and collects in the float box the float rises opening the valve and allowing the vacuum (suction) to draw the accumulated oil through the oil return line back into the inlet of the pump. As the oil level drops in the float box the valve closes "blanking off" the oil return line. The idea is that the oil return line is always full of oil which prevents a loss of vacuum allowing the pump to achieve ultimate pressure and run continuously at the same time.

Newer 0400/0502/0630 pumps are configured with the float valve, but an existing pump in the field can be modified to have this oil float valve assembly by ordering a float valve kit Busch P/N 0946.529.715. Contact the Service Department of Busch, Inc. in Virginia Beach is you wish to add this feature to an older pump in the field or if you are unsure whether you pump has this feature already.

2.3 Gas Ballast

This series of RA pumps are equipped with an adjustable gas ballast valve. The gas ballast valve (Ref. 440) is located between the inlet port and the exhaust box.

The adjustable gas ballast valve should normally be left open. Its primary function is to prevent water vapor from condensing in the pump. Condensation causes emulsification of the oil, loss of lubricity, and possible rotor seizure.

2.4 Water-Cooled Pumps (optional)

Water-cooled pumps are cooled by circulating the oil through a shell-and-tube type heat exchanger (see Fig. 1). The circulation of the cooling water through the tubes is thermostatically controlled. The flow rate of the cooling water is controlled by a thermostatically activated valve.

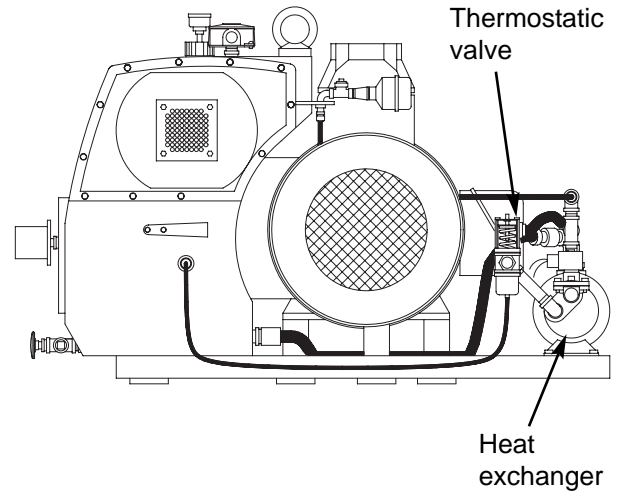

Fig. 1 - Water-cooled Pump

The thermostatic valve can be manually opened by inserting a screwdriver under each side of the spring guide and prying the spring and guide upward away from the valve body.

Refer to your Installation and Operation manual for instructions on adjustment and operation of this valve, or call Busch, Inc. in Virginia Beach, VA. for help.

2.5 Oxygen Service Pumps

WARNING: This pump is filled with a special operating fluid. Do not use any other type of fluid, oil and/or grease. Use one of the following:

- Fomblin LC 250
- Tyreno Fluid 12/25V (perfluorinated polyether)
- KRYTOX ® Vacuum pump fluid by Du Pont Company

If you have any questions, please phone our Customer Service Department for more information.

These pumps have been manufactured, solvent washed (to remove organic contaminants) and assembled according to the latest technical standards and safety regulations. If this pump is not installed properly or not used as directed, a dangerous situation or damage might occur.

For overhaul/repair of oxygen service pumps, Busch Inc. strongly recommends that all major repair operations be conducted at the factory. Improper handling of repairs could result in extreme danger to personnel operating the pump.

Note: Pumps returned to Busch, Inc. for repair or service must be decontaminated and free of harmful or toxic material prior to shipment. Certified documentation of decontamination must be provided prior to the pump's

arrival at Busch. Pumps arriving without certification will, at Busch Inc.'s discretion, be refused shipment or will be re-routed to a commercial decontamination facility. All ensuing decontamination costs will be borne by the shipper.

3.0 ROUTINE MAINTENANCE

R 5 Series pumps require very little routine maintenance; however, to insure optimum pump performance, the following steps are recommended.

3.1 Pump Oil

3.1.1 Oil Level

CAUTION: Do not add oil while the pump is running since hot oil vapor may escape through the oil fill port.

CAUTION: Insufficient oil quantity in the pump has the potential, under certain conditions, to lead to self-ignition of the remaining oil in the pump

With the pump installed relatively level, make sure that there is sufficient clean oil in the pump. The oil level should be observed on a daily basis and/or after 8 hours of operation and should be replenished if it drops below the 1/4 mark on the oil sight glass on pumps with one sight glass or below the 1/4 mark on the upper oil sight glass on pumps with two sight glasses.

On RA Series pumps which do not have an oil level float valve, you must first shut the pump off in order to let the oil flow back into the oil sump prior to checking the sight glass. Allow sufficient time for the oil to drain back into the sump on the pump prior to adding oil, or overfilling could result.

Oil level readings should be done only when the pump is turned off. Oil can be added to the oil fill port (Ref. 88) if the pump is shut off and the circulating oil has sufficient time to return to the oil sump. The oil might appear to be foamy, which is a normal phenomenon with aerated oil.

Under normal circumstances, it should not be necessary to add or drain oil from the pump between recommended oil changes.

A significant drop in oil level means there is an oil leak or that an exhaust filter is broken which would cause the pump to smoke excessively. It is normal for the oil to be foamy and light in color in an operating pump. However, if the oil is milky colored, it is an indication that water is present in the oil. Normally, by operating the pump for an extended period, with the inlet suction blanked off and the gas ballast open on RA pumps, the water will be purged from the oil. If the oil is dark col-

ored, it is contaminated or carbonized and must be changed. Depending on the severity of the contamination, a thorough flushing may be needed. See Section 3.1.4 for the flushing procedure.

3.1.2 Oil Type and Quantity

See Section 1.1 - Oil Filling for details on oil type and quantity.

3.1.3 Oil and Filter Change

Oil life is dependent upon the conditions to which it is exposed. A clean, dry air stream and an oil operating temperature under 210°F are ideal conditions. When using R530 (hydrocarbon oil), it is recommended that oil changes are made every three (3) to four (4) months or 500 to 750 hours of operation, or as necessary if high heat is contaminating the oil. The use of Busch R570 or R590 synthetic oils could extend the operating hours between oil changes under ideal conditions. Oil samples should be taken regularly when exceeding the 500-750 hour recommendation.

CAUTION: When changing the oil and filters, it may be necessary to flush the pump to remove any build-up of degraded oil from the sumps, oil lines, radiators, etc., to ensure proper oil flow through the pump. Reduced oil flow, especially through radiators and cooling coils, can cause mechanical damage or extreme overheating, which could cause the oil vapors to ignite.

Excessive Heat

When the pump is subjected to operating conditions that will cause the oil to be heated above 235°F, the oil will carbonize and become contaminated after a relatively low number of operating hours. The higher the temperature, the quicker the oil becomes contaminated. If the oil temperature is too severe, Busch R570 or R590 synthetic oil should be used to withstand the elevated temperatures. If synthetic oil is used, the pump should be flushed with Busch R568 oil as outlined in Section 3.1.4. Auxiliary oil cooling is the most practical approach to a severe heating problem.

Contaminated Air Stream

When the air stream contains a solid and/or liquid that can contaminate the oil, it must be changed more often. If the air stream contains a small percentage of contaminants and/or they are slightly aggressive (mild acids, etc.), synthetic oil, such as Busch R570, will resist breakdown better than the standard Busch R530. The solution is to install a filter or knock-out pot to keep the contaminants out of the pump.

Process air streams with a large percentage of contam-

inates and/or more than slightly aggressive contaminants must use a once-through-sealant or dry-type pump.

Oil change intervals can only be established by experience with the pump operating in the actual conditions (see previous paragraph for some of the conditions). Develop the oil change interval by periodically checking an oil sample removed from the pump. When the oil sample has become dark in color (from solids and carbonized particles) or is milky looking (from solids), it is time to discard it. As mentioned before, a thorough flushing may be needed.

3.1.4 Oil Flushing Procedure

Flushing is needed under certain conditions. Some pumps will be beyond flushing and will need to be overhauled.

To help determine if flushing is needed, observe the condition of the oil as it is drained from the pump. Is it black and tar like or contaminated in any way? Was the pump noisy, overheating, or was the motor overload shutting the pump off? How old is the pump and when was the last time the oil was changed?

If the above conditions exist or you don't know when the last oil change was performed further investigation is needed. Flushing is always required if changing from one oil type, such as R530, to R570 or R590.

All of the oil will be removed and replaced with the flushing oil (Busch R-568), and eventually that will be replaced by whatever Busch oil is needed for your particular application. Have enough oil and oil filters on hand for a couple of flushes. The following describes the steps in the flushing procedure:

Shut the pump off and drain all the oil from the pump and remove the access plates (Ref. 205) from the exhaust box (Ref. 075). Remove the metal baffle (Ref. 078) and take a good look at the internal walls of the oil sump. If the walls are discolored but have no build up of any kind one can proceed with the flushing. If gelled or burnt oil is clinging to the walls this material must be scraped and removed prior to flushing. Proceed by scraping and cleaning as much of the exhaust box as possible. The more debris that is removed now the more effective the flushing will be later. Re-install the metal baffle, cover and proceed with the flushing. At this point one must remember that the oil lines and oil cooler might also be plugged to a point where no amount of flushing will make a difference and a complete overhaul will be the only option. Depending on the severity of the oil contamination flushing may be a last ditch effort.

Drain all of the oil from the pump. The more contaminated oil you remove now the more effective the oil

flushing will be.

Remove the oil filter (Ref. 100) and install a new one. It is recommended that you do not change the exhaust filter or filters until after the flushing to prevent contamination of any new filters.

Fill the exhaust box with the proper amount of flushing oil (Busch R-568).

If possible run the pump with the inlet closed and off of the process. Run the pump for approximately six hours, shut the pump off and drain a small sample of oil into a clear container.

Examine it. If it is clear to amber run the pump for another six hours and examine it again. If after the first six hours it is black drain it and fill again using another new oil filter.

If after the second flushing the oil still remains black the pump may have too much contaminated oil in it to flush out properly. There may be residue remaining in the lines and cooler that will not flush out. An overhaul will be necessary.

If after the second six hour period the oil still remains clear to amber in color drain it, change the oil filter and fill with the regular oil. At this point also change the exhaust filters.

Run the pump with a fresh charge of the oil to be used in your application (not R-568), and monitor the operating conditions closely. Check for noise, overheating and oil condition until a regular oil change schedule can be established.

Do not let the oil turn black. Change it before it fails. If the oil is kept in good condition the pump will last for years. If the oil starts to turn black do not hesitate to flush again. Keeping on top of the oil changes will prevent costly overhauls.

If you are just switching from one type of oil to another a single six hour flush is all that is necessary (follow the above instructions). Remember to change to a new exhaust filter or filters after the flushing and not before.

3.2 Automotive-Type Oil Filter

To replace the automotive-type oil filter (Ref. 100), the pump should have been running for at least 15 minutes so that the oil is warm. Then switch off the pump, remove the oil drain plug (Ref. 95) and drain the oil. With an automotive-type wrench, remove the oil filter and replace it with a new one. Coat the face of the gasket (new filter) with oil and hand tighten until the gasket contacts the base, then tighten two-thirds turn more. Do not over-tighten. If an O-ring is included, discard it. It is not used in this application. When replacing the

automotive-type filter, use only a genuine Busch filter.

Note: Make sure to tighten the Busch oil filter securely against the aluminum sealing surface so that leaks will not occur.

3.3 Exhaust Filter

WARNING: If the gas entering the pump is a health hazard, use rubber gloves and all necessary personal protection equipment when performing the exhaust filter replacement operation. Wear safety glasses as exhaust filter retainers can, if not secured correctly, slip off and fly out of the exhaust box.

CAUTION: Excessively contaminated and/or clogged exhaust filters could possibly lead to elevated pump temperatures which could, under certain circumstances, cause the lubricating oil to self-ignite.

CAUTION: On 0400/0502/0630 models, a switch mounted on the cover side plate of the exhaust box is a safety device. This switch is used to shut off the pump in the event the pump oil chamber is overheated. Wire this normally closed switch into a starter control circuit so that when the switch reaches the set point, power to the pump is discontinued.

Every nine (9) to twelve (12) months, or as necessary, replace the exhaust filter elements. The service life of the exhaust filters varies widely with pump application. It is only necessary to change the filters when the elements become clogged with foreign material or burned oil. Indications of clogged filters are smoke and oil mist coming from the pump exhaust, higher than normal motor current or oil leaking from the gas ballast valve on RA models.

A pressure gauge (Ref. 90) is supplied with your R 5 vacuum pump as part of the oil fill plug. This gauge has a green field and a red field. Pressure within the green field would indicate normal pressure. Pressure in the red field (for a continuous period of time) requires an immediate change of the exhaust filter(s).

In order to replace the filter, remove the screws retaining the exhaust port cover plate. Pull the housing off the exhaust box; set it aside. Use a slotted head screw driver to loosen the exhaust filter retaining spring (Ref. 125), then rotate and remove the spring. Pull the filter cartridge (Ref. 120) out of the exhaust box.

To field test an exhaust filter element, remove it from the pump, allow it to cool, clean the sealing end (or O-ring end), and use compressed air to blow through the

element. Apply approximately 3 to 6 psi (maximum allowable operating pressure across the filter).

WARNING: Do not inhale through the filter or allow your mouth to come in direct contact with the filter.

Use a shop rag to seal off the connection between the air hose and the filter. If you can blow through it, the element is not plugged. If plugged, discard it and install a new one. The filter cannot be cleaned successfully. Visually inspect the filter element for cracks.

Reinstall the filter elements. Make sure the open end of the element is properly seated down in its recess in the exhaust box with the O-ring (Ref. 121) correctly positioned. Retain the filter with the spring clip, tighten the tension screw until the filter is secure. Place the exhaust port gasket and cover in position on the exhaust box and retain with the cap screws.

3.4 Vacuum Inlet Filter

If the pump is equipped with a special vacuum inlet filter in applications where powder, dust or grit is present, the filter cartridge should be cleaned on a weekly basis, or as required, depending on the amount of foreign particles to which the pump is exposed.

To clean the inlet filter, unsnap the lid clamps or remove the knobs and lift off the filter lid. Remove cartridge, being careful not to knock any foreign particles present inside the canister into the pump suction. Clean foreign particles from the canister with an air hose, and carefully back flush the filter cartridge with shop air. If the filter cartridge has been subjected to moisture or is extremely dirty, it may need replacement.

3.5 Routine Maintenance Schedule

See the motor manufacturer's manual for the periodic motor maintenance.

Daily: Visually check oil level (see 3.1.1).

Weekly: Check oil for contamination (see 3.1.3). Inspect inlet filter (see 3.4).

Every three (3) or four (4) months, 500 to 750 hours of operation, or as necessary: See 3.1.3 and 1.5. Drain and discard oil from the hot pump. Replace the automotive-type oil filter and refill with fresh oil through the fill plug (see 3.1.2 through 3.1.3 and 3.2).

Every nine (9) to twelve (12) months, or as necessary: Replace exhaust filter elements (see 3.3).

3.6 Overhaul Kit/Filter

An overhaul kit containing a set of gaskets and O-rings, vanes, bearings and bearing sleeves, shaft seals and taper pins, is available from the factory. Also, a filter kit containing oil drain plug, gaskets, automotive-type oil filter, exhaust filter, and synthetic baffle strainer (where applicable), is available from the factory. When ordering, please specify pump size and model (a 4-digit suffix after size), and serial number.

4.0 DISASSEMBLY

All R 5 Series, Single Stage, Rotary Vacuum pumps should only be disassembled and reassembled by qualified personnel. Caution must be exercised to prevent damage to the pump components.

4.1 Necessary Tools

To disassemble/assemble all the R 5 Series pumps, the following tools are recommended:

Allen Wrench: 2.5mm, 4mm, 6mm, 12mm
Filter Wrench: (Strap wrench)
Open End Wrench: 10mm, 12mm, 13mm, 15mm, 17mm, 19mm, 22mm, 24mm, 27mm, 32mm
Socket Wrench with Extension: 10mm, 13mm, 17mm, 19mm, 24mm
Hex Head Nut, Regular Pitch: 6mm, 8mm
Screwdriver
Drum Plug Wrench
Rubber Mallet
Gear Puller (Fan and Coupling)
Dial Indicator with Magnetic or Clamp-on Base
Arbor Press to Install Bearing and Shaft Seals
Loctite 242 for Shaft Seal and Bearing Installation
Miscellaneous Feeler Blades 18 inches long: .03mm, .04mm, .06mm, .07mm, .09mm.
Shaft Seal Bearing Installation Tool, Shaft Seal Installation Sleeve, and Rotor Pulling Tools (Available from Busch, Inc. in Virginia Beach).

4.2 Complete Disassembly

WARNING: Shut the pump off. Lock the electrical panel in the off position to prevent the power from accidentally being reinstated during the operation.

Shut the pump off and disconnect power supply to the motor. Drain the oil through the oil drain plug (Ref. 95). (See pump illustrations Figures 16, 17 and 18 for part identifications.) Tilt the pump toward the oil drain plug, allowing it to drain.

Remove the motor (Ref. 400) from the motor mounting bracket (Ref. 300) by removing four hex head cap screws (Ref. 401).

Remove the pump side coupling half (Ref. 310) by loosening the set screws. A gear puller will be necessary to pull the coupling off the rotor shaft. Extreme care must be given to the end of the rotor shaft so that the shaft center is not damaged by the gear puller.

Note: "Wood's" type couplings have a special spacer, one on the motor shaft and one on the pump shaft. Mark these for correct reassembly before removing them.

Remove the motor mounting bracket (Ref. 300) from the cylinder endplate (Ref. 25) by removing three (3) hex head nuts (Ref. 303).

Remove the oil cooling coil (Ref. 240) (not applicable on 0502/0630 pumps) by loosening the fittings from the exhaust box and the pump module.

Remove the fan cover (Ref. 340) from the cylinder endplate (Ref. 26) by removing the three (3) sheet metal screws (Ref. 341).

Remove the fan (Ref. 321) from the rotor shaft of the pump module by loosening the set screw. On 0400/0502/0630 pumps, there is a locking disc (Ref. 327) connected to the end of the fan side rotor shaft which needs to be removed prior to removing the fan. Remove the fan (Ref. 321) with a gear puller. There is also a distance ring (Ref. 320) behind the fan that needs to be removed (0400/0502/0630 only).

Model 0502/0630 pumps are equipped with a cooling radiator (Pos 241) installed at the fan side of the pump. The following oil fittings need to be loosened (Ref. 221, 223, 224). Remove the six hex head cap screws (Ref. 357) which will allow the removal of the radiator and radiator side center ring (Ref. 351). It is now possible to remove the fan guard (Ref. 352), fan (Ref. 321), distance ring (Pos 320), and center ring (on endplate side) (Ref. 350).

On RA pumps, the gas ballast valve (Ref. 440) can now be removed from the fan side endplate.

On RC pumps, remove the oil return line (Ref. 290) from the inlet flange (Pos 260) and the exhaust box (Ref. 75). On RA Models, oil non return valve (Ref. 275) should be removed and checked.

WARNING: Do not apply pressure or vacuum by mouth.

Loosen and remove all hydraulic fittings connected to the endplates (Ref. 25/26) and the exhaust box (Ref. 75).

Remove the exhaust box cover plate (Ref. 205) which is located to the right of the oil sight glasses.

With the inside of the exhaust box now visible, the exhaust valve cover plate (Ref. 169) with gasket (on RA pumps only) can now be removed by loosening and removing a hex head nut or a bolt in the center of the cover plate.

If only the exhaust valves (Ref. 159) need to be taken out or replaced, it will not be necessary to separate the pumping module from the exhaust box.

To separate the pump cylinder (Ref. 1) from the exhaust box (Ref. 75), remove the hex head cap screws (Ref. 186) with lockwashers (Ref. 187) from within the exhaust box. On 0160/0250 models, there are internal and external nuts and screws that have to be removed.

The exhaust box can now be separated from the pump module. The gasket (Ref. 185) can be removed and replaced, if necessary.

The exhaust valves can now be removed by loosening the slotted machine screw with a large screwdriver (for plastic valves) or with a 10mm socket wrench (for all steel valves).

The sheet metal piece (Ref. 78), which is located towards the bottom of the exhaust box, and the steel demister (Ref. 79), which is located towards the fill plug inside the exhaust box, can now be removed for cleaning or replacement. The sheet metal piece will require some bending to remove it.

The inlet housing (Ref. 260) can be removed from the module by removing four hex head cap screws (Ref. 265). The inlet housing comes in two pieces. The inlet screen should be cleaned or replaced. The anti-suck-back valve (Ref. 251-255) needs to be looked at to assure proper function. Check to see that the valve plate (Ref. 251) moves freely and seats properly. The spring (Ref. 254) should be adjusted so it holds the valve plate slightly ajar. All O-rings and/or gaskets should be replaced, if necessary, before reassembling.

To check exhaust filters (Ref. 120), it will be necessary to remove the exhaust end cover plate (Ref. 140) by removing either the hex head cap screws (Ref. 142) for the 0160 model or the socket head cap screws (Ref. 142) for the 0400/0502/0630 models. The synthetic baffle (Ref. 130) needs to be removed and replaced, if necessary.

WARNING: Wear safety glasses when removing or installing the exhaust filter springs. Be prepared for the possibility of the spring suddenly releasing if it is not in the spring pocket correctly.

Remove filter springs (Ref. 125) by loosening pan head machine screw (Ref. 126) with a screwdriver. Push the filter spring with a large screwdriver from the frame so

that the spring assembly pops out. Slide the exhaust filters (Ref. 120) with O-rings (Ref. 121) out of the exhaust box. Examine filter elements to see if they are clogged. See Section 3.3 for details.

To replace the automotive type oil filter (Ref. 100), the pump should have been running for at least 15 minutes, so that the oil is warm. Then turn the pump off, remove the oil drain plug (Ref. 95), and drain the oil. With an automotive type filter wrench (strap wrench), remove the oil filter, and replace with a new one. Coat face of gasket on new filter with oil and hand tighten until gasket contacts base, then tighten two-thirds turn more. Do not overtighten. Use only a genuine Busch filter.

4.3 Disassembly of Pump Module

Set module on a table or vise with the exhaust port facing down and the inlet facing you (see Fig. 8 and 9).

Remove threaded taper pin (Ref. 60) by placing a washer or lockwasher over thread and then a 6mm or 8mm nut against the washer/lockwasher to loosen the taper pins. Use of a lockwasher acting as a spring will ease removal. In essence, the washer/lockwasher is used as a spacer and the 6mm or 8mm nut is used as a jackscrew to draw the pin out.

Remove the hex head cap screws (Ref. 53) so the endplate may be separated from the pump cylinder. Be careful not to damage the sealing faces, O-ring (Ref. 50) or paper gaskets between the endplates. If the endplates do not come off easily, tap gently with a rubber mallet or soft hammer, or remove all threaded studs (Ref. 4) from the cylinder. On older pumps with gaskets between endplates and cylinder, take note how many, and the thickness of the gaskets used on each side of the cylinder. The same quantity and thickness can be used upon assembly if no major parts were replaced or machined.

The rotor (Ref. 15) and vanes (Ref. 22) can now be removed from the cylinder (Ref. 1). Care must be taken when removing the rotor to prevent damaging the rotor or the cylinder.

Inspect vane slots for wear. The slot walls should be parallel to each other. If the slots are worn in a V pattern the rotor should be replaced. Insert a new vane in the slot and measure the gap between the vane and the slot wall. If the gap exceeds .3mm replace the rotor. Check the rotor for trueness before reassembly. This can be done by chucking the rotor in a lathe and checking the run-out or eccentricity (T.I.R.). The maximum allowable run-out is 0.02mm (0.001"). See the Clearances Chart on page 21.

The bearings (Ref. 30) and shaft seals (Ref. 35) can be removed from the endplates via an arbor press using a bearing and shaft seal removal tool (see Fig. 2 and 3).

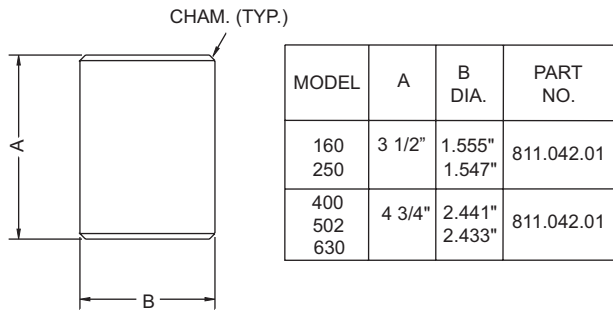

Fig. 2 - Disassembly of Bearing Module

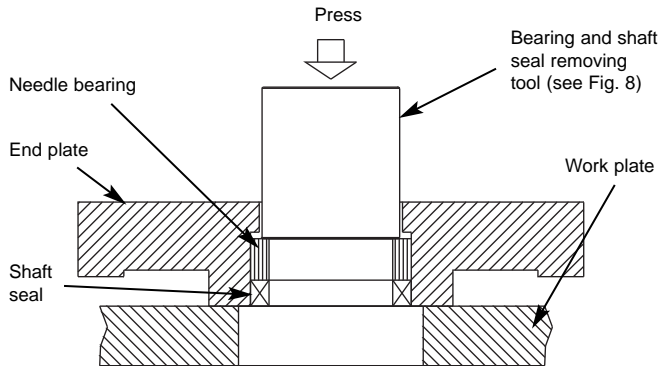

Fig. 3 - Bearing and Shaft Seal Removal Tool

To remove the bearing and/or seal sleeves (Ref. 18) from the rotor, clean the rotor shaft with a fine emery cloth, removing any possible residue buildup or nicks and bruises. Stand the rotor on end with the end from which the sleeve is being removed facing down. Heat the sleeve with a propane torch, being careful to concentrate heat on the sleeve while the rotor is being slowly turned; the sleeve should then fall off. If the sleeve does not come off with this method, a pencil grinder should be used to grind the sleeve off. Care must be taken not to grind into any part of the rotor shaft. The sleeve will usually pop when you get close to the rotor shaft.

5.0 CLEANING PROCEDURES

After disassembly of pump, it will be necessary to clean all parts in a suitable solvent such as acetone or trichloroethylene. All flat surfaces should be honed with a honing stone to assure flatness. If the cylinder is scored on the inside, the surface can be honed. The endplates, cylinder, and rotor should not be machined without first consulting with Busch Service Department in Virginia Beach. They can be honed with a flat honing stone or fine emery cloth.

Old gasket material might have to be removed with a putty knife.

Exhaust filters (Ref. 120) cannot be cleaned and reused. Replace clogged or damaged filters with new

ones.

Synthetic baffles (Ref. 130/131) need to be replaced if brittle and dark colored.

Rotor slots need to be cleaned and polished with a fine emery cloth to assure loose movement of vanes in the rotor slots. Check rotor surfaces and edges for bruises or burrs and use either emery cloth or a fine file to remove any bad spots on the rotor. The flat ends of the rotor need to be honed with a flat honing stone; no machining should be attempted. Do not push or sand the areas of the shaft where the bearing and seal sleeves sit.

6.0 PREPARATION FOR ASSEMBLY

6.1 Endplate Preparation

As the endplate is prepared for assembly pay particular attention to honing of surfaces, O-ring or gasket replacement, bearings and shaft seal installation, vacuum grease in shaft seals, oil in needle bearings, Loctite on outside circumference of bearing and shaft seal and shaft seal retainer plate on new version to be put on after module has been reassembled.

6.2 Exhaust Box Preparation

All inside parts should have been removed and cleaned or replaced. After cleaning, return the sheet metal baffle (Ref. 78) in the bottom of the reservoir. Replace steel demister pad (Ref. 79). A new synthetic baffle (Ref. 130) needs to be placed behind the exhaust filters. New drain plugs with their respective O-ring gaskets are included in the filter kit so they should be replaced. A new automotive type oil filter (Ref. 100) should be put on the exhaust box.

7.0 ASSEMBLY

7.1 Exhaust Valves

Prior to assembling the exhaust valves, examine the sealing surfaces for rust, pitting or corrosion. Check the spring washers to be sure they have retained their spring tension. If any part is not in good enough condition replace the whole valve assembly (see Fig. 4).

Put Loctite 242 on the bottom of the valve stem, thread and screw the valve assembly into the matching hole on pump cylinder. Correct assembly of the exhaust valve is critical.

Prior to attaching the steel exhaust valve assembly to the cylinder, check to see that the valve plate (washer-type piece) moves freely.

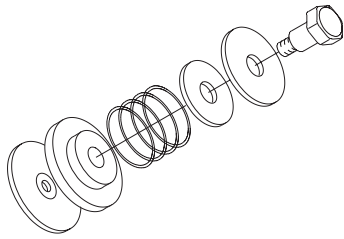
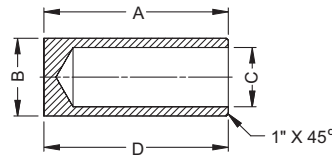

Fig. 4 - Exhaust Valve Assembly

the shoulder of the rotor. Use the bearing sleeve installation tool (see Fig. 5) to position the sleeve.



D	3.150	5.906
C	1.200	1.783
B	1.575	2.047
A	3.740	6.496
	0160/0250	0400/0502/0630

Dimensions are in inches

7.2 Bearings, Bearing Sleeves, Shaft Seals

If the bearing and seal sleeves (Ref. 18) have been removed the new bearing sleeves need to be preheated prior to installation. Preheat sleeves in an oil bath (approximately 250°F), an induction bearing heater or a hot plate. Install the sleeves on the shaft so they touch

Fig. 5 - Bearing Installation Tool

Bearings should be installed using an arbor press and special tool (see Fig. 6) to insure proper depth of bearings. Using a hammer to install the bearings may damage them. Other special tools are also required for installation of the bearings and shaft seals (see Fig. 7).

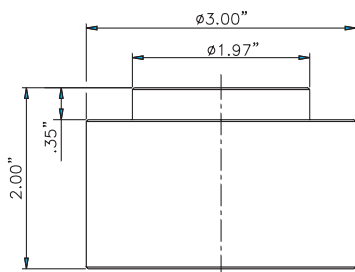
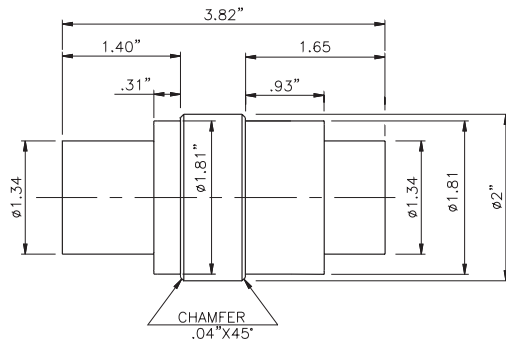
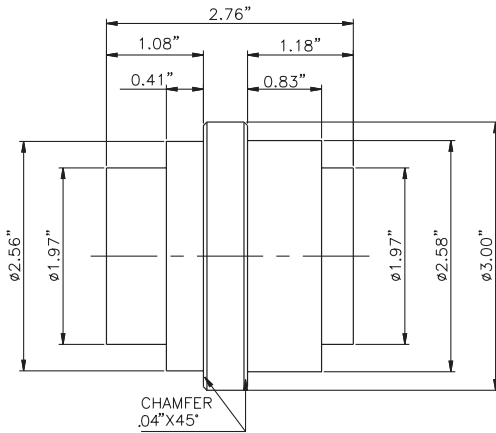

CHAMFER ALL SHARP EDGES

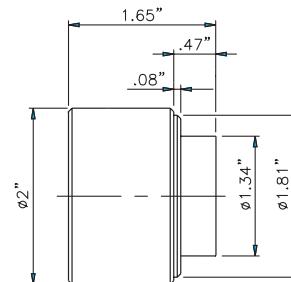

Fig. 6 - Bearing and Shaft Seal Installation Tools

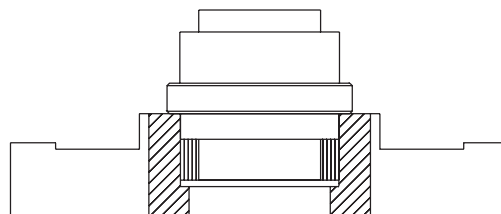

Fig. 7 - Shaft Seal Installation Tool

The shaft seal (Ref. 35) should be installed with the spring side towards the bearing. Verify that the shaft seal is equipped with a spring on the inner lip. Prior to installing the shaft seal in the endplate, put a drop of Loctite No. 242 on the outside circumference of the shaft seal. Be sure that the correct seals (Buna or Viton) are installed.

7.3 Pump Module for Regular Overhaul

For the 0160/0250 pumps only, place the pump cylinder (Ref. 1) in a vise (see Fig. 8). Position of the assembly depends on whether you have an older style, or a newer style of pump.

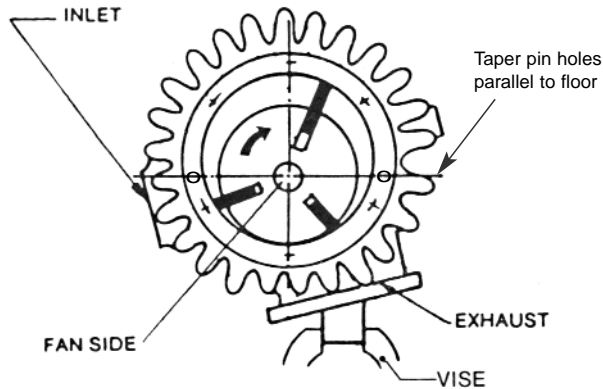

Fig. 8 - Position of Cylinder for RA/RC 0160

For the 0400/502/0630 pumps only, place the cylinder on a work bench with the inlet port facing you and the exhaust port facing down (see Fig. 9). Place two small pieces of 2x4s under the cylinder so that it will raise the cylinder enough to be able to slip the endplates on later. The cleaning procedure of the rotor in Section 5.0 must be followed prior to installation of the rotor. With the inlet of the cylinder (Ref. 1) facing you, the left will be the motor side. Slide the rotor (less vanes) inside the cylinder with the longer rotor shaft towards the motor side. Take care not to damage the cylinder or rotor.

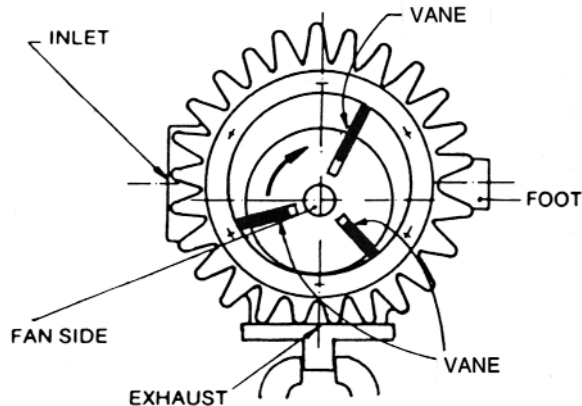

Fig. 9 - Position of Cylinder for RA/RC 0400, 0502 and 0630

Place the vanes inside the rotor slots with the relief grooves, if any, on the trailing side (see Fig. 9).

Endplates (Ref. 25 and 26) should have been prepared as indicated in Section 6.1. If only a normal overhaul was performed and the rotor, endplates or cylinder were not replaced, the following procedure should be followed. Carefully insert the endplates over the shaft. The endplate with the fan cover mounting bosses (Ref. 26) goes on the fan side of the module (see Fig. 10).

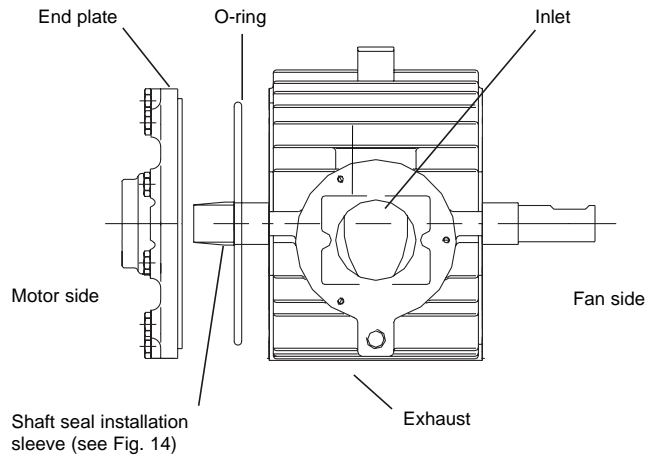

Fig. 10 - Endplate Installation

Care must be taken not to damage the shaft seal when sliding over the bearing sleeve. Preferably, one should use a special shaft seal installation sleeve (see Fig. 11).

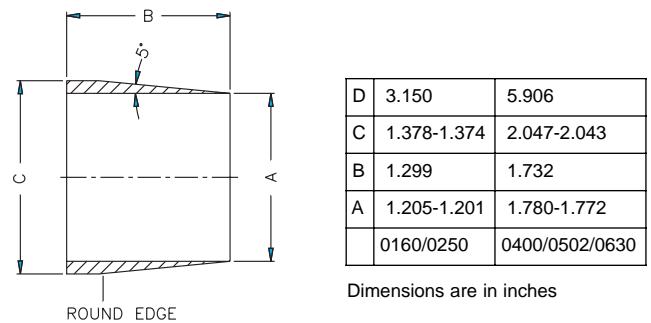

Fig. 11 - Shaft Seal Installation Sleeve

Note: Models 0160/0250-132/128, 0400/502/0630-212/218, use a large O-ring (Ref. 50) to seal the endplate on the cylinder. Models 0160/0250-112/118 use a paper gasket material to seal the endplate to the cylinder. On pumps with paper gaskets, use the same quantity and thickness on each side as were removed during disassembly. Cases in which it is not possible to identify what gaskets were removed, use one thick (0.1mm-.0039") gasket on each side. Place the paper gasket over the studs on the pump cylinder. With endplates in place, install the taper pins (Ref. 60) hand-tight, and loosely tighten the nuts and bolts of the endplates by hand. Tap the taper pins into the endplate and cylinder with a hammer until a solid sound is heard. Now proceed to tighten all nuts and bolts with a wrench.

It will now be necessary to check for proper axial and radial clearances. The axial clearance is checked by installing a dial indicator on one end of the shaft (see Fig. 12). Pull the opposite end of the shaft as far as it will pull away from the dial indicator. Set the indicator at zero (0). Push the shaft toward the dial indicator as far as it will push. The reading on the dial indicator will be your axial clearance. The recommended axial clearances are shown in the chart located near the back of this manual (see page 21).

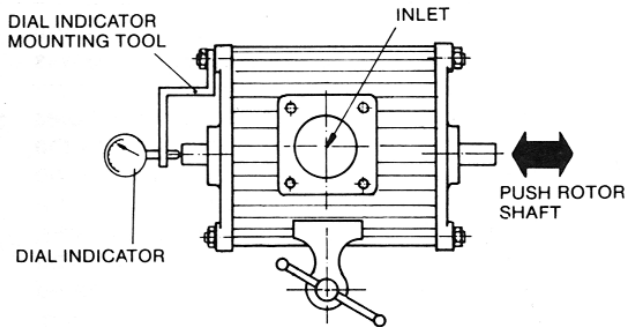

Fig. 12 - Axial Clearance Measuring

Check the radial clearances (see Fig. 13) by inserting a feeler gauge blade into the inlet of the pump in the direction of the smallest clearance between rotor and cylinder. Check the radial clearance in three (3) locations along the rotor. The recommended radial clearances are shown in the chart located near the back of this manual (see page 21).

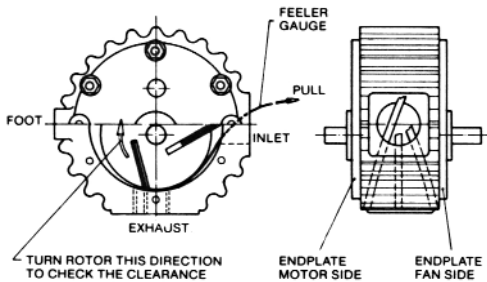

Fig. 13 - Checking Radial Clearance

If clearances check out okay, one may proceed to assemble the pump. If clearances do not correspond to what they should be or if a new rotor, endplates or cylinder were used, one will have to use the procedure mentioned for Assembly of Module if the Rotor, Endplates or Cylinder had to be replaced.

Note: On Models 0160/0250-112/118, the axial clearances can be changed by either placing another paper gasket between the cylinder and endplate to increase the axial clearance or using a thinner gasket to decrease the axial clearance. There should always be at least one (1) gasket between the cylinder and endplate. On models with O-rings, the axial clearance is preset and cannot be changed, but if the rotor sits in the cylinder uneven (meaning cocked), it will give a false

axial clearance reading. The rotor needs to be aligned straight with respect to the cylinder to be able to get the necessary axial clearance.

Assembly of Module if the Rotor, Endplates, or Cylinder had to be Replaced:

Make sure that all parts have been wiped clean of oil and that flat surfaces have been honed with smooth sand stone prior to assembly.

With the cylinder (Ref. 1) in the vise (0160/0250 only) positioned as indicated in Figs. 8 or 9, measure the length of the cylinder and the length of the rotor (Ref. 15) with a micrometer or other available measuring device, if at all possible. These measurements can help in determining axial clearance in the assembled stage. If the above measured axial clearance is not obtained after the endplates are assembled, it gives an indication that the rotor is cocked inside the cylinder housing. If a micrometer or other measuring device is not available, use the recommended distances mentioned in the clearance chart.

Place the rotor (Ref. 15) carefully inside the pump cylinder (Ref. 1) with the long shaft end on the motor side. With the inlet of the cylinder facing you, the motor side is to your left.

Place vanes inside the rotor slots. Check the vanes to be sure they do not extend beyond the length of the rotor; if they are too long, sand down the ends with a medium grade sand paper (see Fig. 9). Make sure that the rotor is not resting on one of its slots when assembling.

Insert two .07mm (0.0027 in.) feeler gauge blades for 0160/0250 pumps and .08mm (0.0031 in.) for 0400/502/0630 pumps through the inlet, over the top and underneath the rotor to the far left and far right position of the cylinder (see Figure 13). The rotor should be sitting on the feeler blades. The feeler gauge shown in Fig. 13 is only for checking radial clearances after assembly.

Slide motor side endplate (Ref. 25) onto the rotor shaft using a seal installation tool (see Fig. 11) and install cap screws hand tight. Slide fan side endplate (Ref. 26) on rotor shaft and hand-tighten bolts.

Install the rotor pulling tool (see Fig. 14) onto the fan side rotor shaft. Use the puller to pull the rotor toward the fan side endplate squaring the end of the rotor to the face of the endplate. Rotate the rotor and endplate (within the endplate mounting holes) until the two taper pins can be inserted into the cylinder. Push (by hand) the pins into the cylinder, providing a partial alignment intended to return the assembly near its original position. If the cylinder was machined, the taper pin holes will be slightly off.

Note: A new cylinder will not have taper pin holes. A new endplate will only have pilot holes.

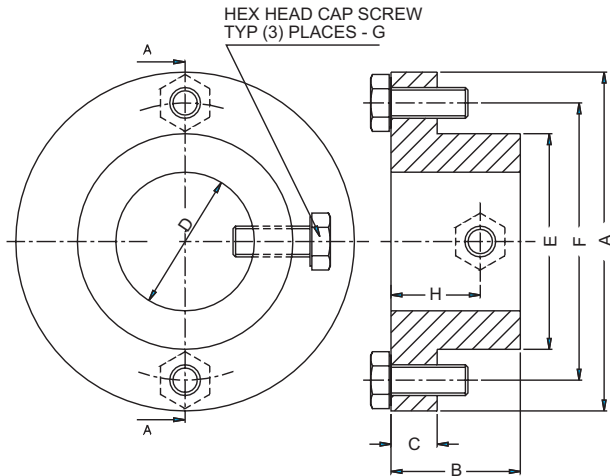

Pump	A	B	C	D	E	F	G	H
160/250	90	100	15	30.2-30.5	50	72	M8x30	30
400/502 630	110	42	15	45.2-45.3	70	90	M10x25	29

Dimensions are in mm

Fig. 14 - Rotor Pulling Tool

When new parts are used the rotor and fan side endplate should be rocked back and forth (within the clearance of the mounting holes) until the bolts are centered within the holes. Once the endplate is centered, tighten the mounting bolts.

When the existing parts are used but the cylinder has been machined proceed with the loosely inserted taper pin method. After tightening the fan side endplate mounting bolts, proceed to the motor side endplate. Center the motor side endplate by loosely inserting the taper pins or by the "feel" method of working it back and forth. Tighten the motor side endplate mounting bolts.

Loosen the rotor pulling tool, but leave the pulling tool on the shaft since it will assist you in turning the rotor.

Remove the feeler blades by turning the rotor from the fan side counterclockwise (see Fig. 13). Check the tips of the feeler gauge blades to make sure nothing has broken off. It will be necessary to remove the broken piece, and start over if a piece of the feeler gauge blade has broken off.

Attach a dial indicator on the motor side rotor shaft as indicated in Fig. 12 to check axial clearance. Do not change anything until the radial clearance is checked. Follow the same procedures as mentioned previously. If the resistance of the feeler blades between the rotor and the cylinder feel tighter on one end of the cylinder than the other, use a hammer to tap the endplate on

the tighter side slightly upward until an even resistance of the feeler blade can be measured on both ends of the rotor. A difference of .02mm (.0008 inch) radial clearance can be tolerated between the fan side and the motor side of the rotor as long as the minimum clearance is maintained. If the rotor is square with the endplates, but the rotor to cylinder clearance between the motor side and fan side differs more than .02mm, the cylinder must be remachined. The rotor should turn freely after the removal of the feeler blades.

The axial clearance should be checked again and if the readings are still not within the correct tolerances, it is recommended to start over again. Both the axial and radial clearances have to be within the recommended tolerances in order to proceed. A reworked cylinder can occasionally be machined with a taper or irregularity in the bore. If a bore is suspected to be irregular, it is all the more important to make sure the end of the rotor is parallel with the inside face of the endplates.

After clearances are correct, proceed to prepare to drill out the taper pin holes by closing the inlet with a clean rag and covering the bearing seals with a rag. Plug any open holes in the endplates. Look into the taper pin holes in the endplates with a flashlight to see how close the old taper pin holes are from the endplate, and line up the taper pin holes in the cylinder. If the holes are only slightly off, redrill the holes with the same size tapered drill as was used originally. If the holes do not line up very close, it will be necessary to drill out the holes to the next larger size and use taper pins the next larger size. To prevent from drilling too deeply into the pumping module, it is recommended to measure the depth of the old holes. Make yourself a mark with tape on your drill bit to assure the proper depth. Use a tapered reamer to ream the holes out after drilling. These tools are available from Busch, Inc.

Put a little bit of "Never Seize" on the new taper pins and insert them into the endplates. Lightly tap them with a hammer to insure proper seating.

Squirt oil into the pump module and turn rotor by hand to lubricate vanes and rotor slots well. The pump can now be reassembled.

7.4 Pump Assembly

When the pump module was separated from the exhaust box for repair, follow these reassembly instructions:

Reconnect exhaust valves (Ref. 159) on the pumping module for 112/132/212 pumps. See Section 7.1.

Reconnect the pumping module to the exhaust box (Ref. 75) after placing the proper gasket (Ref. 185) in between the module and the exhaust box.

Attach all oil lines leading from the exhaust box to the module endplates (Ref. 231/232), except the oil return line (Ref. 290).

The oil lines on Model 0630 connect to the radiator and are then distributed to the endplates.

Reconnect the oil cooling coil (Ref. 240) (not applicable on Model 0502/0630).

Make sure all hydraulic fittings are good and tight.

Attach motor mounting bracket (Ref. 300) to the motor side endplate (Ref. 25).

Prior to Bowex "gear type" coupling installation (Ref. 310), check serrated edges of the coupling halves for burrs that would prohibit the coupling insert from sliding freely. Install the pump side coupling half (Ref. 310) and tighten set screws. A distance of 4mm must be maintained between the pump coupling half and the motor coupling half when the pump and motor are connected (see Fig. 15).

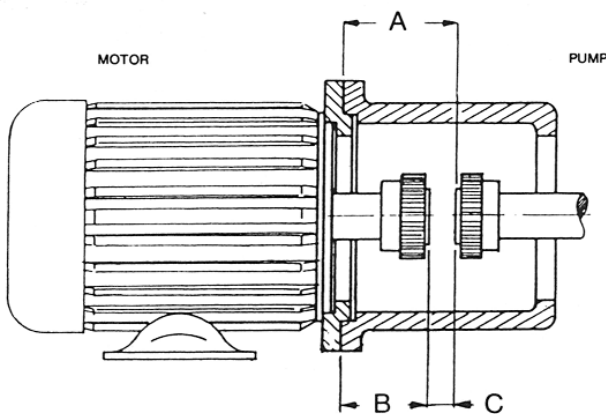

Fig. 15 - Coupling Adjustment

Measure the distance from the end of the pump coupling half to the face surface of the motor mounting bracket, which is indicated in Figure 15 as Distance "A". Subtract 4mm from Distance "A". This measurement is the distance from the motor coupling, which is indicated in Figure 15 as Distance "B". This is for Bowex couplings only. The most current coupling used is a "Wood's" type coupling. This coupling when properly adjusted, will allow the sleeve to move 1mm (clearance) back and forth from flange to flange. The pump and motor come from the factory with a set of spacers that automatically set the correct sleeve clearance. If these spacers are reassembled the same as originally installed, the clearance will be correct. Place a locking disc on the end of the motor shaft to hold coupling and cooling fan in place. Coupling set screws cannot be tightened due to the cooling fan; that is why a locking disc is used. For the 0502/0630 pump, mount the pump coupling half in such a way so that the coupling half protrudes outward from the rotor shaft by 10mm. The

motor coupling half is mounted flush against the motor shaft and is held in place by two set screws.

Note: Make sure to Loctite set screws in place for all couplings and motor fans to prevent movement.

CAUTION: The rotor in this pump is free floating. If the coupling is too tight it will, when hot, force the rotor into the fan side endplate causing damage to the pump.

Install the gas ballast (Ref. 440) on the fan side endplate (Ref. 26) on 112, 132, and 212 models only.

Install the fan side cooling fan (Ref. 321) flush against the rotor shaft bearing sleeve (Ref. 18) on the 0160/0250 models. Tighten set screws on the fan mounting boss. On the 0400 models, insert a distance ring (Ref. 320), then slip on the fan (Ref. 321) and tighten the set screw. Attach the fan cover (Ref. 340) on the fan side endplate (Ref. 26). For the 0502/0630 pumps slip on the distance ring (Ref. 320). Attach the metal shroud (Ref. 350) to the endplate (Ref. 26). Attach the fan (Ref. 321) and tighten the set screw. Place the locking disc (Ref. 327) on the shaft end. Attach the radiator side metal shroud (Ref. 351) with the fan cover guard (Ref. 352) and distance bolts (Ref. 355), in place. Reconnect the radiator (Ref. 241) with the radiator bracket on the metal shroud. Reconnect all the oil lines at the same time.

Squirt Busch R530 oil into the pump module and turn the rotor by hand to lubricate the vanes and rotor slots.

Attach the inlet housing (Ref. 260 and 250) to the module using a gasket (Ref. 255) on Models 0160/0250-112/118 and 0400/0502/0630-212/218, or an O-ring (Ref. 80) on Models 0160/0250-132/138 or new type 0400/0502/0630-212/218. Make sure the anti-suck-back valve is functioning and that the O-ring (Ref. 253) is in good condition.

Reconnect the oil return line (Ref. 290) or non-return valve (Ref. 275). Do not over-tighten.

Connect the motor (Ref. 400) to the motor mounting bracket (Ref. 300) with the fan (Ref. 322) attached to the motor shaft for pump Models 0160/0250-112/118, 132, 138 and 0400-212/218. The 0502/0630 model does not use this fan. Make sure the motor coupling half is on the motor shaft and the coupling insert has been placed on the module side coupling half. See Figure 15 for proper coupling insert play.

Fill the pump to the proper level on the oil sight glasses with Busch 500 Series oil.

Connect the proper power supply to either the motor conduit box or the pump manual starter. Be sure all the connections are tight.

Jog the pump to determine the correct rotation of the pump. The pump rotation should be counterclockwise when looking at the motor fan from the motor end. If the rotation is incorrect, change any two of the three lead wires and check the rotation again.

8.0 CHANGING FROM RA TO RC MODEL

If a pump needs to be changed to either a RA or a RC pump, it can easily be done by following the instruction below.

Drain the oil.

Remove the oil non-return valve (Ref. 275) and copper washer (Ref. 276) from the end of the exhaust box.

Remove the plug (Ref. 270) and copper washer (Ref. 271) from the inlet flange.

The gas ballast valve (Ref. 440) can be removed if there is no chance of water vapor condensing in the pump module. If water condensation could be a problem, it is recommended that the gas ballast is left in place. The gas ballast can easily be removed on 0160/0250 and 0400 pumps by removing the fan cover (Ref. 340) and the fan (Ref. 321). After removing the gas ballast, be sure to close the opening with a plug (Ref. 46) and a copper washer (Ref. 47). The hex head screws (Ref. 441/442), which hold the gas ballast bracket to the exhaust box, can be reinstalled by placing some Loctite and a copper washer on the screw. To remove the gas ballast from a 0502/0630 pump, it is recommended to lift the pump in the air and remove the hydraulic fitting without removing the radiator. It is very tight to get in there, but it can be done.

If the vacuum requirements are only in the 15 Torr range, it is recommended to remove the exhaust valves (Ref. 159) on the 132 and 212 models. On Model 112, the valves can be left in, since it would take a complete disassembly of the pump to remove them. See Section 4.2 for removal of exhaust valves.

Connect the oil return line (Ref. 290) with the elbow fitting (Ref. 291) to the inlet flange where the 1/8" plug and washer (Ref. 270/271) were removed. The elbow fitting needs to be screwed into the inlet before attaching the oil line to it (use some Loctite 242).

Connect the banjo fitting (Ref. 286) to the other end of the oil line. Make sure that the lipped end of the banjo fitting is facing the exhaust box.

Do not over-tighten the banjo screw (Ref. 285) or the threads inside the aluminum exhaust box will be stripped.

To change from a RC 118, 138, 218 to a RA 112, 132, 212, use the same instruction in the reverse order. You

might not be able to obtain an end vacuum of 29.98 in Hg. at blank-off. Please consult the factory for further information.

8.1 Difference between RA and RC Pumps

The RC model pumps 118/138/218 can run continuously because any oil buildup in the exhaust filter area of the exhaust box is constantly being sucked through the oil return line into the module through the inlet flange. Since this oil return line will also carry some atmospheric air, it reduces the vacuum level at blank-off to about 15 Torr or 29.3 in. Hg.

On RA model pumps an oil non-return valve is used. It is a ball check valve. When the pump is running, this check valve will close automatically. When the pump is not in operation, the check valve will open up and allow the oil from the exhaust filter area to drain into the pump oil sump.

Older RA pumps had to be shut down periodically to allow any oil buildup to drain back into the sump. If this was not done, the oil would collect in the exhaust filter area to a point where it would be blown out of the exhaust port; the pumping module was also being deprived of oil which could result in vane damage. Since there was no atmospheric air being introduced at the inlet through an oil return line, the pump was able to run at a blank-off pressure of .5 Torr or 29.9 in. Hg.

Newer model RA 0400/0502/0630 pumps are provided with an oil level float valve as described in Section 2.2, but an older existing pump in the field can be modified to have this oil float valve assembly by ordering a float valve kit Busch P/N 0946.529.715. Contact the Service Department of Busch, Inc. in Virginia Beach if you wish to add this feature to an older pump in the field or if you are unsure whether your pump has this feature already.

9.0 OIL LEVEL SWITCH INSTALLATION

Contact the factory.

10.0 TROUBLE SHOOTING

10.1 Trouble

The pump does not reach "blank-off" pressure which is the lowest absolute pressure (best vacuum) when running with the inlet covered via a blank flange or a valve; or pump takes too long to evacuate the system. The blank-off pressure can be measured by using a good quality capsule gauge.

Possible Cause:

Contaminated oil is by far the most common cause of not reaching the ultimate pressure.

Remedy:

Shut off the pump after operating temperature has been reached, drain the warm oil from the pump, and exchange automotive type oil filter, if necessary. Flush and fill pump with new oil and take a new blank-off measurement after the operating temperature is reached (at least 20-30 minutes).

Possible Cause:

Vacuum system or vacuum piping is not leak-tight.

Remedy:

Check hose and pipe connections for possible leaks.

Possible Cause:

Wire mesh inlet screen plugged (Ref. 261).

Remedy:

Clean the wire mesh inlet screen. Install an inlet filter if problem repeats frequently.

Possible Cause:

No oil or not enough oil in oil reservoir.

Remedy:

Shut off the pump, add the necessary oil, or oil seems contaminated, drain the balance of the oil from the pump, exchange the automotive type oil filter, and refill with fresh oil. Flush if necessary.

Possible Cause:

The automotive type oil filter is dirty or clogged (where applicable).

Remedy:

Replace the automotive-type oil filter, exchange the oil, if necessary, and refill with fresh oil.

Possible Cause:

The inlet anti-suck-back valve plate (Ref. 251) is stuck in the closed or partially open position due to contamination.

Remedy:

Disassemble the inlet valve and screen. Clean as required.

Possible Cause:

Oil tubing fittings are loose and leaking. Oil return line broken on RC model.

Remedy:

Replace or retighten oil fittings or oil tubing. Replace only with the same size tubing.

Possible Cause:

Shaft seal leaking.

Remedy:

Replace the shaft seal following disassembly and assembly instruction. Check the shaft seal. It should have a spring installed inside and around the shaft sealing lip. Check and replace the shaft seal/bearing sleeve if worn.

Possible Cause:

The exhaust valve (Ref. 159) is not properly seated or is partially stuck open (RA models only).

Remedy:

Follow the disassembly and assembly instructions or contact the nearest Busch Factory Service Center.

Possible Cause:

Vanes are stuck in rotor or otherwise damaged.

Remedy:

Free vanes or replace with new ones following disassembly and assembly instructions or contact the nearest Busch Factory Service Center.

Possible Cause:

Radial clearance between the rotor and cylinders is no longer adequate.

Remedy:

Follow disassembly and assembly instructions on resetting radial clearance correctly.

Possible Cause:

Internal parts worn or damaged.

Remedy:

Follow the disassembly and assembly instructions and replace worn or damaged parts.

10.2 Trouble

The pump will not start.

Possible Cause:

The motor does not have proper supply voltage or is overloaded; motor starter overload settings are too low or wrong setting, fuses are burned; wire size is too small or too long, causing a voltage drop at the pump.

Remedy:

Check correct supply voltage; check the overload settings in the motor starter for size and setting according to the motor nameplate data; check fuses; install the proper size wire. If the ambient temperature is high, use the next larger size overloads or adjust the setting 5% above the nominal motor nameplate value.

Possible Cause:

Pump or motor is blocked.

Remedy:

Remove the fan cover and try to turn the pump and motor by hand. If frozen, remove the motor from the pump and check the motor and pump separately. If the pump is frozen, disassemble completely and remove foreign objects in the pump or replace broken vanes.

10.3 Trouble

Pump starts, but labors and draws a very high current.

Possible Cause:

Oil is too heavy (viscosity too high) or the ambient temperature is below 5C° (41°F).

Remedy:

Change to R580 vacuum oil if very cold, or warm up the pump oil before filling.

Possible Cause:

Pump runs in the wrong rotation.

Remedy:

Check for correct rotation which is counterclockwise when looking at the motor from the motor's fan side.

Possible Cause:

Pump is overfilled with oil, or wrong kind of oil is used.

Remedy:

Correct oil level and quality, and use only Busch vacuum oil.

Possible Cause:

Exhaust filters in exhaust are clogged and burned black with pump oil.

Remedy:

Replace exhaust filters; maintain proper oil condition, oil level and use Busch R500 Series vacuum oil.

Possible Cause:

Exhaust filter is clogged due to process material.

Remedy:

Contact factory for recommendation or proper filter cartridge.

Possible Cause:

Loose connection in motor terminal box, not all motor coils are properly connected. Motor operates on two phases only.

Remedy:

Check motor wiring diagram for proper hook-up, especially on motors with six internal motor windings, tighten and/or replace loose connections.

Possible Cause:

Foreign particle in pump; vanes broken; bearing seizing.

Remedy:

Follow disassembly and assembly instructions and remove foreign parts; replace vanes and bearings.

10.4 Trouble

Pump smokes at the exhaust side or expels oil droplets from the exhaust.

Possible Cause:

Exhaust filter not properly seated with O-ring (Ref. 121) in filter base or filter material is cracked.

Remedy:

Check condition and check for proper seating of exhaust filters. Replace if necessary. Also, check filter spring clips for tightness.

Possible Cause:

Exhaust filter clogged with foreign particles.

Remedy:

Replace the exhaust filter.

Possible Cause:

Oil non-return valve (Ref. 275) not working properly. Proper function is that when blowing compressed air into the check valve, it should close. When applying vacuum on it, the check valve should open.

Remedy:

Free or replace the oil return check valve.

Possible Cause:

If an older RA Series vacuum pump run continuously over 8 hours without ever being shut down, it may be possible that oil accumulates behind the exhaust box cover (Ref. 140) to the extent that oil is blown out of the exhaust with the exhaust gas.

Remedy:

Shut pump down during break periods. Check that oil return valve (Ref. 275) is free and drains oil back into the exhaust box oil sump when the RA pump is stopped.

Possible Cause: Oil return line (Ref. 290) on RC pumps is clogged or broken.

Remedy:

Free the clogged line, replace the broken line, but only with the proper size, and check that the oil is pumped out of the oil sump while the vacuum pump is operating.

Note: An oil filling plug with pressure gauge is supplied as a standard item for all R 5 Series pumps so that the pressure in front of the exhaust filters can be monitored. The green field indicates that the filters are still effective. Any back pressure in the red field requires immediate change of the exhaust filter (Ref. 120).

10.5 Trouble

Pump runs very noisy.

Possible Cause:

Coupling insert is worn.

Remedy:

Replace coupling insert motor/pump coupling.

Possible Cause:

Bearing noise.

Remedy:

Follow disassembly/assembly instructions outlined in this manual and the replace bearings.

Possible Cause:

Vanes stuck.

Remedy: Follow disassembly/assembly instruction; replace vanes. Use R500 Series vacuum oil.

10.6 Trouble

Pump runs very hot.

Note: The oil temperature with a closed inlet should be approximately 185-225°F depending on pump type. At 24 in. Hg, the oil in the pump can go above 225°F. These values are taken at an ambient temperature of 68°F. The maximum recommended ambient operating temperature for an R 5 is 100°F on a continuous basis. When it is necessary to operate a pump in ambient temperatures above this limit, careful oil monitoring and/or optional water cooling is necessary. Contact the factory at Virginia Beach for details.

Possible Cause:

Not enough air ventilation to the pump.

Remedy:

Clean motor and pump air grills. Do not install pump in enclosed cabinet unless sufficient amount of fresh air is supplied to pump. On pumps with oil cooling coils, clean outside fin assembly. Bring ambient air temperature down.

Possible Cause:

The automotive type oil filter (Ref. 100) is clogged and pump does not receive enough oil.

Remedy:

Change automotive oil filter.

Possible Cause:

Not enough oil in oil reservoir or badly burned oil is used for pump lubrication.

Remedy:

Flush (see Section 3.1.4) and refill only with Busch recommended oil. Increase oil change intervals.

Note:

On some high temperature applications, it may be necessary to change to a high temperature oil such as R590 or R570. Contact the factory for recommendations.

10.7 Trouble

Pump is seized.

Possible Cause:

Pump was operated without oil and vanes broke.

Remedy:

Disassembly and exchange vanes per instructions.

Possible Cause:

Pump was operated for an extended period of time in the wrong rotation.

Possible Cause:

Liquid carryover into pump cylinder broke the vanes while pump was running or oil broke the vanes on start-up.

Remedy:

Install condensate trap on the inlet of the pump. Or, pump was overfilled with oil in oil reservoir. Follow oil filling procedure (see Section 1.1) and do not overfill. Or, built-in anti-suck-back valve (Ref. 250 through 255) is leaking while pump was shut down and vacuum was left in manifold. Clean valve seat and check that anti-suck-back valve holds vacuum on inlet when pump is shut down. Or, two pumps or a receiver is on the same main line. Install a manual or automatic operated valve in front of each pump.

10.8 Trouble

Automotive-type oil filter (Ref. 100) does not get warm within two to five minutes when cold pump is started.

Possible Cause:

Automotive-type oil filter is clogged.

Remedy:

Replace oil filter and exchange oil.

Possible Cause:

Wrong automotive-type filter is used and/or oil lines leading to pump are clogged.

Remedy:

Use only the proper Busch genuine oil filter and blow lines free.

11.0 LIMITED STANDARD WARRANTY

Busch, Inc. warrants that all products furnished by it are free from defects in material and workmanship at the time of shipment for a period of 18 months from the date of shipment, or 12 months from the date of installation, whichever occurs first. Claims must be made during that period and are limited to the replacement or repair of parts claimed to be defective.

In the case of components purchased by Busch, Inc., such as starters, controls, mechanical seals, motors, couplings, etc., the warranty of that manufacturer will be extended to the purchaser in lieu of any warranty by Busch, Inc. The replacement of wear items including, but not limited to, seals, bearings, couplings, exhaust cover gaskets, oil drain plugs, oil fill plugs etc., made in connection with normal service are not covered by this Warranty.

The Limited Standard Warranty is valid only when the product has been properly installed, used in a normal manner, and serviced according to the operating manual. This warranty shall not extend to products that have been misused, neglected, altered, or repaired without factory authorization during the warranty period. We highly recommend the use of Busch oils and parts to achieve documented performance and efficient operation. The use of oils or parts other than Busch could limit the life expectancy of the equipment and could void any warranties if they are the cause of any damage. Operating conditions beyond our control such as

improper voltage or water pressure, excessive ambient temperatures, or other conditions that would affect the performance or life of the product will also cause the warranty to become void.

Permission to return parts for warranty repair must be obtained, and all returns must be prepaid to the factory. If, after examination, the product or part is found to be defective, it will be repaired or replaced on a no-charge basis and returned, FOB the factory. If it is determined that the Warranty has not been breached by Busch, Inc., then the usual charges for repair or replacement will be made, FOB the factory. Parts or products that are obsolete or those made to special order are not returnable.

This Limited Standard Warranty applies only to the above and is for the period set forth. Busch, Inc.'s maximum liability shall not, in any case, exceed the contract price for the product, part, or component claimed to be defective; and Busch, Inc. assumes no liability for any special, indirect, or consequential damages arising from defective equipment.

THERE ARE NO WARRANTIES IMPLIED OR EXPRESSED THAT EXTEND BEYOND THOSE CONTAINED IN THIS LIMITED STANDARD WARRANTY.

Note: For extended warranties on your new equipment contact Busch, Inc. Headquarters at 1-800-USA-PUMP.

Technical Data

Model		0160	0250	0400	0502	0630
Nominal pumping speed	ACFM	115	170	305	375	455
Free air displacement	CFM	117	180	330	413	490
Maximum sound level 1 meter from pump	dBA	79	81	83	84	85
Motor size for 3 phase	HP	7.5	10	15	20	25
Motor rotational speed	rpm	1750	1750	1150	1150	1150
Approximate oil capacity	qt.	7	7	14	16	16
Inlet connection - NPT	inch	2	2	3	3	3
End vacuum (RC)	Torr	15	15	15	15	15
End vacuum (RA)*	Torr	0.5	0.5	0.5	0.5	0.5
Approximate weight	pounds	416	460	1152	1316	1525

* Without gas ballast

Clearance Chart

TYPE	Length of Cylinder	Rotor	Cylinder	Vanes	Axial	Radial	Bearings Needle
160	140	+0.0 -0.025	+0.070 +0.050	-0.04 -0.08	max 0.095 min 0.050	0.03 0.07	0.020- 0.040
250	220	+0.0 -0.029	+0.100 +0.080	-0.12 -0.15	max 0.129 min 0.080	0.03 0.07	0.020- 0.040
400	265	+0.0 -0.032	+0.190 +0.165	-.18 -0.21	max 0.222 min 0.165	0.10 0.06	0.050- 0.035
502	330.6	+0.0 -0.032	+0.200 +0.175	-0.20 -0.24	max 0.232 min 0.175	0.10 0.06	0.050- 0.035
630	400	+0.0 -0.036	+0.245 +0.215	-0.20 -0.24	max 0.281 min 0.215	0.06 0.10	0.035- 0.050

After assembling the endplates, a reduction of .01mm of axial clearance is allowed. Clearances are listed in millimeters.

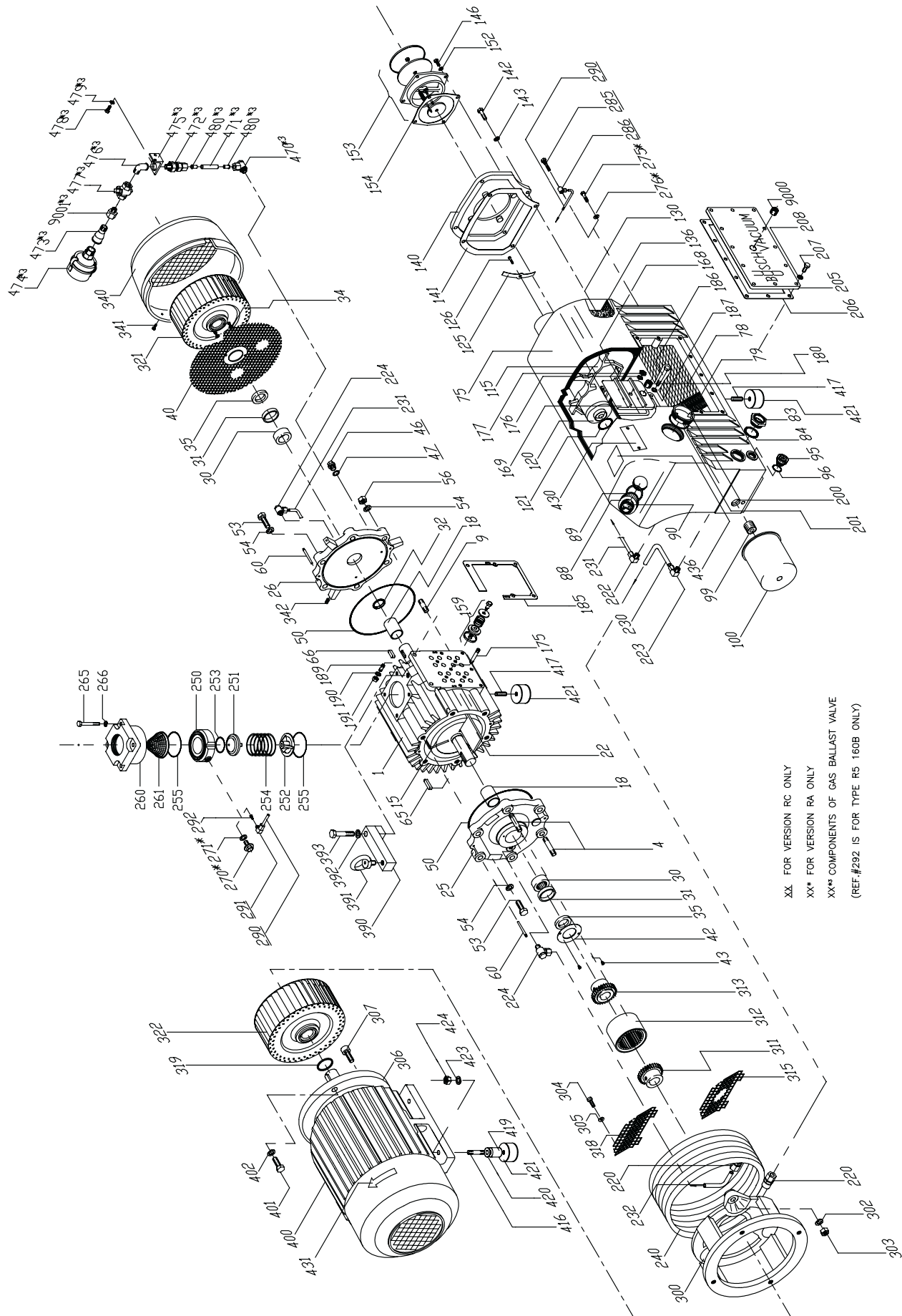
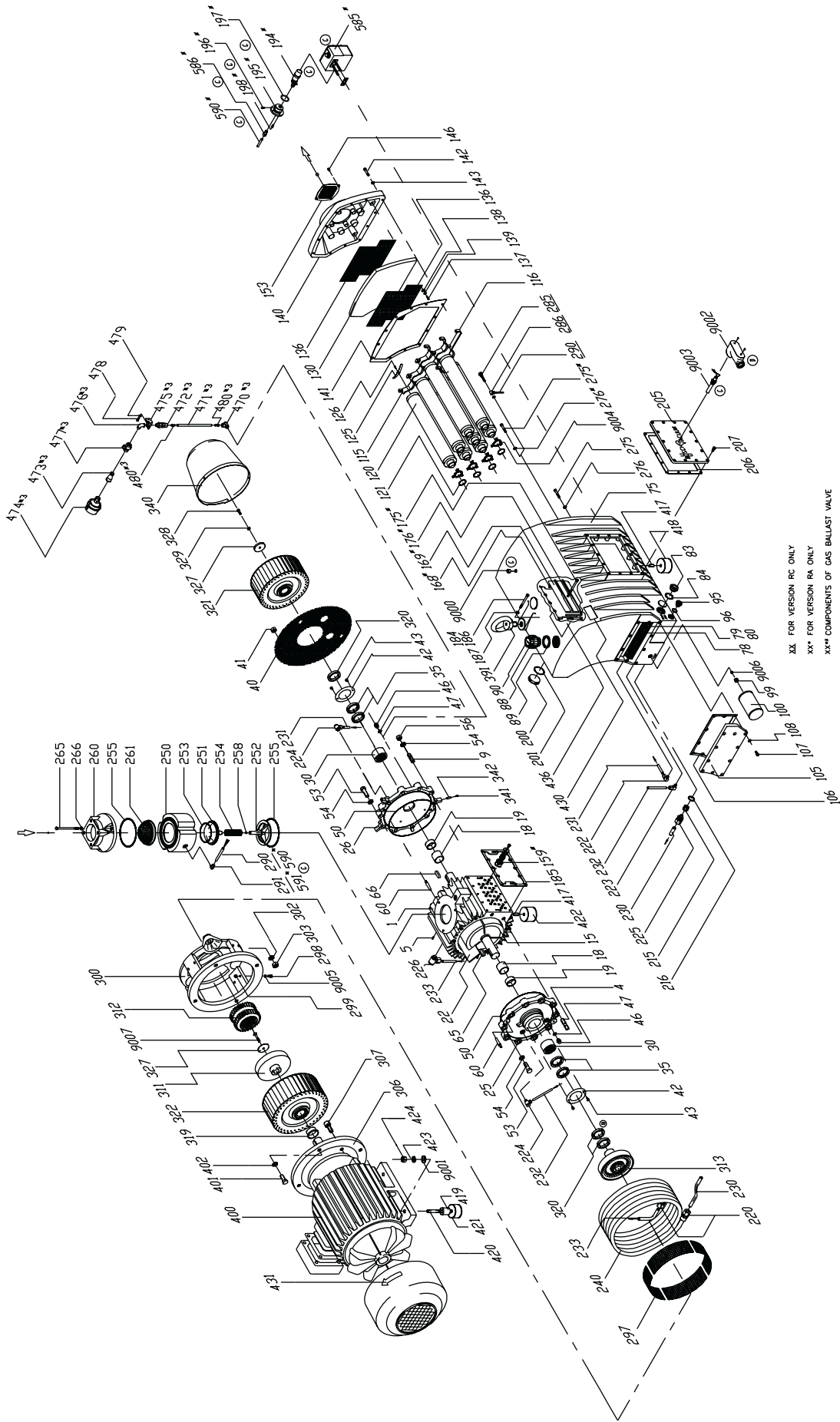

Fig. 16 - Illustration of R 5 0160 Vacuum Pump

Parts List for R 5 0160

Ref	Description	Ref	Description	Ref	Description
001	Cylinder	176	Lockwasher	322	Motor side fan
004	Stud	177	Hex head nut	340	Fan Cover
009	Stud	180	Plug	341	Sheet metal screw
015	Rotor	185	Gasket	342	Plastic insert
018	Bearing sleeve	186	Hex head cap screw	390	Eyebolt adapter
022	Vane	187	Lockwasher	391	Eyebolt
025	Motor side endplate	189	Stud	392	Lockwasher
026	Opp. M.S. endplate	190	Lockwasher	393	Hex head cap screw
030	Needle bearing	191	Hex head nut	400	Motor
031	Endplate spacer	200	Drum exhaust box plug	401	Hex head cap screw
032	Pump spacer	201	O-ring	402	Lockwasher
034	Slotted chs. hd. cap screw	205	Cover side plate	416	Stud
035	Shaft seal	206	Gasket	417	Slotted set screw
040	Protective screen	207	Hex head cap screw	419	Foot spacer
042	Shaft seal retaining plate	208	Lockwasher	420	Flat washer
043	Hex head cap screw	220	Hydraulic fitting	421	Rubber foot
046	Hex head plug	222	Hydraulic fitting	423	Washer
047	Copper ring gasket	223	Hydraulic fitting	424	Hex head cap nut
050	O-ring	224	Hydraulic fitting	430	Nameplate
053	Hex head cap screw	230	Oil tubing	431	Arrow label
054	Lockwasher	231	Oil tubing	436	Maintenance label
056	Hex head cap nut	232	Oil tubing	470	Hydraulic fitting
060	Tapered pin	240	Cooling coil	471	Teflon tubing
065	Shaft key	250	Inlet flange	472	Check valve
066	Shaft key	251	Valve guide	473	Bell reducer
075	Exhaust box	252	Valve plate	474	Gas ballast filter
078	Sheet metal baffle	253	O-ring	475	Gas ballast valve bracket
079	Demister pad	254	Inlet check valve spring	476	Elbow fitting
083	Oil sight glass	255	O-ring	477	Pet cock valve
084	Ring gasket	260	Inlet flange	478	Hex head cap screw
088	Oil fill plug	261	Inlet screen	479	Lockwasher
089	Oil fill plug gasket	265	Hex head cap screw	480	Oil tube insert
090	Pressure gauge	266	Lockwasher	9000	Steel socket plug
095	Oil drain plug	270	Plug	9001	Hydraulic adapter
096	O-ring	271	Ring gasket		
099	Nipple	275	Oil return valve		
100	Auto-type oil filter	276	Ring gasket		
115	Filter bracket	285	Oil recirc. screw		
120	Exhaust filter	286	Banjo hydraulic fitting		
121	O-ring	290	Oil return line tubing		
125	Filter spring assembly	291	Hydraulic fitting		
126	Socket head cap screw	292	Carburetor jet		
130	Baffle strainer	300	Motor mounting bracket		
136	Baffle strainer frame	302	Lockwasher		
140	Exhaust cover plate	303	Hex shoulder nut		
141	Cover plate gasket	304	Socket hd. machine screw		
142	Hex head cap screw	305	Flat washer		
143	Lockwasher	306	C-face adapter flange		
146	Hex head cap screw	307	Socket head screw		
152	Lockwasher	311	Motor side coupling half		
153	Exhaust silencer	312	Coupling insert		
154	Gasket	313	Pump side coupling half		
159	Exhaust valve	315	Protective screen		
168	O-ring	318	Protective screen		
169	Exh. valve cover plate	319	Spacer		
175	Stud	321	Pump shaft fan		



XX FOR VERSION RC ONLY
 XX* FOR VERSION RA ONLY
 XX** COMPONENTS OF GAS BALLAST VALVE

Fig. 17 - Illustration of R 5 0400 Vacuum Pump

Parts List for R 5 0400

Ref	Description	Ref	Description	Ref	Description
001	Cylinder	143	Lockwasher	312	Coupling insert
004	Stud	146	Hex head cap screw	313	Pump side coupling half
005	Set screw	153	Cover plate exhaust screen	319	Spacer
009	Stud	159	Exhaust valve	320	Fan and coupling spacer
015	Rotor	168	O-ring	321	Pump shaft fan
018	Bearing sleeve	169	Exh. valve cover plate	322	Motor side fan
019	Shaft seal sleeve	175	Hex head cap screw	327	Locking disk
022	Vane	176	Lockwasher	328	Socket head cap screw
025	Motor side endplate	184	Socket head cap screw	329	Lockwasher
026	Opp. M.S. endplate	185	Cylinder/Exhaust box gasket	340	Fan Cover
030	Needle bearing	186	Hex head cap screw	341	Sheet metal screw
035	Shaft seal	187	Lockwasher	342	Plastic insert
040	Protective screen	200	Drum exhaust box plug	391	Eyebolt
041	Hex head nut	201	O-ring	400	Motor
042	Shaft seal support ring	205	Cover side plate	401	Hex head cap screw
043	Hex head cap screw	206	Gasket	402	Lockwasher
046	Hex head plug	207	Hex head cap screw	417	Slotted set screw
047	Copper ring gasket	215	Reducing nipple	418	Rubber foot
050	O-ring	216	Ring gasket	419	Foot spacer
053	Hex head cap screw	220	Hydraulic fitting	420	Stud
054	Lockwasher	222	Hydraulic elbow fitting	421	Rubber foot
056	Hex head cap nut	223	Hydraulic elbow fitting	422	Rubber foot
060	Tapered pin	224	Hydraulic banjo fitting	423	Lockwasher
065	Shaft key	225	Hydraulic straight fitting	424	Hex head cap nut
066	Shaft key	226	Hydraulic banjo fitting	430	Nameplate
075	Exhaust box	230	Oil tubing	431	Arrow label
078	Sheet metal baffle	231	Oil tubing	436	Maintenance label
079	Demister pad	232	Oil tubing	470	Hydraulic banjo fitting
080	Perforated sheet metal	233	Oil tubing	471	Teflon tubing
083	Oil sight glass	240	Cooling coil	472	Check valve
084	Ring gasket	250	Inlet flange	473	Bell reducer
088	Oil fill plug	251	Valve plate	474	Gas ballast filter
089	Oil fill plug gasket	252	Valve inlet guide	475	Gas ballast valve bracket
090	Pressure gauge	253	O-ring	476	Elbow fitting
095	Oil drain plug	254	Inlet check valve spring	477	Pet cock valve
096	O-ring	255	O-ring	478	Hex head cap screw
099	Nipple	258	Ball, Viton	479	Lockwasher
100	Auto-type oil filter	260	Inlet flange	480	Oil tube insert
105	Cover plate	261	Inlet screen	9000	Steel socket plug
106	Cover plate gasket	265	Hex head cap screw	9001	Flat washer
107	Socket head cap screw	266	Lockwasher	9002	Entrance elbow connector
108	Lockwasher	275	Oil return valve	9003	Fenwal temperature switch
115	Filter bracket	276	Ring gasket	9004	Grounding washer
116	Filter bracket	285	Oil recirc. screw	9005	Plain washer
120	Exhaust filter	286	Banjo hydraulic fitting	9006	Socket head cap screw
121	O-ring	290	Oil return line tubing	9007	Hex head cap screw
125	Filter spring assembly	291	Hydraulic elbow fitting		
126	Socket head cap screw	297	Screen		
130	Baffle strainer	298	Slot chs.. head screw		
136	Perf. sheet metal screen	299	Rivet		
137	Hex head cap screw	300	Motor mounting bracket		
138	Flat washer	302	Lockwasher		
139	Lockwasher	303	Hex shoulder nut		
140	Exhaust cover plate	306	C-face adapter flange		
141	Cover plate gasket	307	Socket head screw		
142	Hex head cap screw	311	Motor side coupling half		

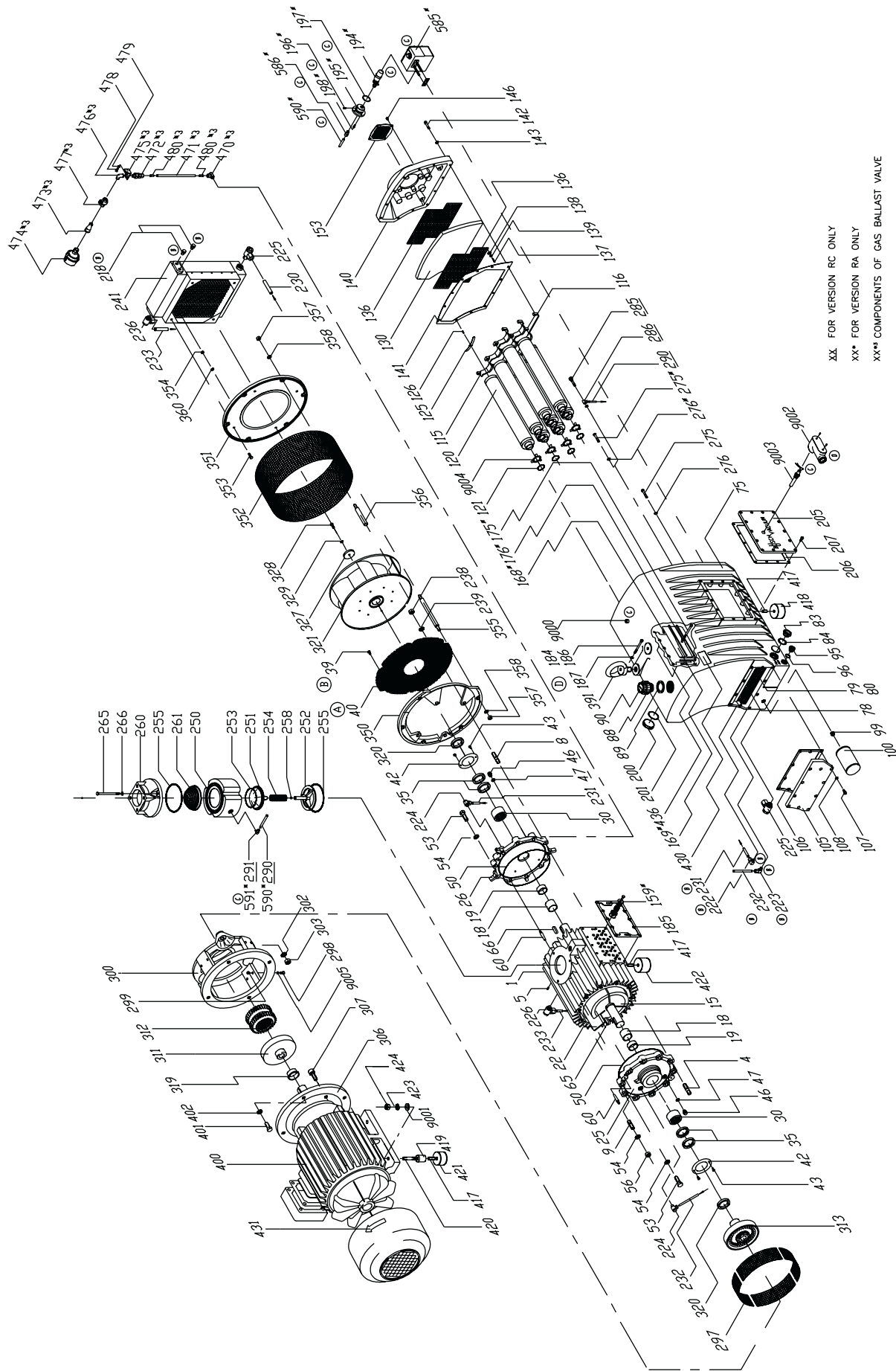

Fig. 18 - Illustration of R 5 0502/0630 Vacuum Pump

Parts List for R 5 0502/0630

Ref	Description	Ref	Description	Ref	Description
001	Cylinder	141	Cover plate gasket	313	Pump side coupling half
004	Stud	142	Hex head cap screw	319	Spacer
005	Set screw	143	Lockwasher	320	Fan and coupling spacer
008	Stud	146	Hex head cap screw	321	Pump shaft fan
009	Stud	153	Cover plate exhaust screen	327	Locking disk
015	Rotor	159	Exhaust valve	328	Socket head cap screw
018	Bearing sleeve	168	O-ring	329	Lockwasher
019	Shaft seal sleeve	169	Exh. valve cover plate	350	Centering ring
022	Vane	175	Hex head cap screw	351	Centering ring
025	Motor side endplate	176	Lockwasher	352	Fan guard
026	Opp. M.S. endplate	184	Socket head cap screw	353	Hex head cap screw
030	Needle bearing	185	Cylinder/Exhaust box gasket	354	Hex head nut
035	Shaft seal	186	Hex head cap screw	355	Distance bolt
039	Socket head mach. screw	187	Lockwasher	356	Mounting bolt
040	Protective screen	200	Drum exhaust box plug	357	Hex nut
041	Hex head nut	201	O-ring	358	Lockwasher
042	Shaft seal support ring	205	Cover side plate	360	Lockwasher
043	Hex head cap screw	206	Gasket	391	Eyebolt
046	Hex head plug	207	Hex head cap screw	400	Motor
047	Copper ring gasket	222	Hydraulic elbow fitting	401	Hex head cap screw
050	O-ring	223	Hydraulic elbow fitting	417	Slotted set screw
053	Hex head cap screw	224	Hydraulic banjo fitting	418	Rubber foot
054	Lockwasher	225	Hydraulic straight fitting	419	Foot spacer
056	Hex head cap nut	226	Hydraulic banjo fitting	420	Stud
060	Tapered pin	230	Oil tubing	421	Rubber foot
065	Shaft key	231	Oil tubing	422	Rubber foot
066	Shaft key	232	Oil tubing	423	Lockwasher
075	Exhaust box	233	Oil tubing	424	Hex head cap nut
078	Sheet metal baffle	236	Hydraulic fitting	430	Nameplate
079	Demister pad	238	Hex head nut	431	Arrow label
080	Perforated sheet metal	239	Lockwasher	436	Maintenance label
083	Oil sight glass	241	Oil cooler	470	Hydraulic banjo fitting
084	Ring gasket	250	Inlet flange	471	Teflon tubing
088	Oil fill plug	251	Valve plate	472	Check valve
089	Oil fill plug gasket	252	Valve inlet guide	473	Bell reducer
090	Pressure gauge	253	O-ring	474	Gas ballast filter
095	Oil drain plug	254	Inlet check valve spring	475	Gas ballast valve bracket
096	O-ring	255	O-ring	476	Elbow fitting
099	Nipple	258	Ball, Viton	477	Pet cock valve
100	Auto-type oil filter	260	Inlet flange	478	Hex head cap screw
105	Cover plate	261	Inlet screen	479	Lockwasher
106	Cover plate gasket	265	Hex head cap screw	480	Oil tube insert
107	Socket head cap screw	266	Lockwasher	585	Oil return float valve kit
108	Lockwasher	285	Oil recirc. screw	586	Hydraulic fitting
115	Filter bracket	286	Banjo hydraulic fitting	591	Hydraulic fitting
116	Filter bracket	290	Oil return line tubing	9000	Steel socket plug
120	Exhaust filter	297	Screen	9001	Flat washer
121	O-ring	298	Slot chs. head screw	9002	Entrance elbow connector
125	Filter spring assembly	299	Rivet	9003	Fenwal temperature switch
126	Socket head cap screw	300	Motor mounting bracket	9004	Grounding washer
130	Baffle strainer	302	Lockwasher	9005	Plain washer
136	Perf. sheet metal screen	303	Hex shoulder nut	9006	Socket head cap screw
137	Hex head cap screw	306	C-face adapter flange	9007	Hex head cap screw
138	Flat washer	307	Socket head screw		
139	Lockwasher	311	Motor side coupling half		
140	Exhaust cover plate	312	Coupling insert		