

Chemtech Scientific provides access to this content as a courtesy.
We do not own the content contained in this document.
All rights and credit go directly to its rightful owners.
www.chemtechsci.com
Call us at: 484-424-9415



Instruction Manual

R5

Rotary Vane Vacuum Pumps

RB 0021 C

RC 0021 C



Table of Contents

1 Safety	3
2 Product Description	4
2.1 Operating Principle.....	4
2.2 Application	5
2.3 Optional Accessories.....	5
2.3.1 Gas Ballast Valve.....	6
2.3.2 Inlet Filter	6
2.3.3 Filter pressure gauge.....	6
3 Transport	6
4 Storage	7
5 Installation	8
5.1 Installation Conditions	8
5.2 Connecting Lines / Pipes	8
5.2.1 Suction Connection.....	9
5.2.2 Discharge Connection.....	9
5.3 Filling Oil.....	10
5.4 Electrical Connection	11
5.4.1 Wiring Diagram Single-Phase Motor.....	11
5.4.2 Wiring Diagram Three-Phase Motor	12
6 Commissioning	13
6.1 Version with Oil Return Valve.....	13
6.2 Conveying Condensable Vapours	13
7 Maintenance	14
7.1 Maintenance Schedule.....	15
7.2 Oil Level Inspection	15
7.3 Oil Change	15
7.4 Exhaust Filter Change	17
8 Overhaul	18
9 Decommissioning	18
9.1 Dismantling and Disposal.....	18
10 Spare Parts	19
11 Troubleshooting	20
12 Technical Data	22
13 Oil	22
14 EU Declaration of Conformity	23

1 Safety

Prior to handling the machine, this instruction manual should be read and understood. If anything needs to be clarified, please contact your Busch representative.

Read this manual carefully before use and keep for future reference.

This instruction manual remains valid as long as the customer does not change anything on the product.

The machine is intended for industrial use. It must be handled only by technically trained personnel.

Always wear appropriate personal protective equipment in accordance with the local regulations.

The machine has been designed and manufactured according to state-of-the-art methods. Nevertheless, residual risks may remain. This instruction manual highlights potential hazards where appropriate. Safety notes and warning messages are tagged with one of the keywords DANGER, WARNING, CAUTION, NOTICE and NOTE as follows:

DANGER

... indicates an imminent dangerous situation that will result in death or serious injuries if not prevented.

WARNING

... indicates a potentially dangerous situation that could result in death or serious injuries.

CAUTION

... indicates a potentially dangerous situation that could result in minor injuries.

NOTICE

... indicates a potentially dangerous situation that could result in damage to property.

NOTE

... indicates helpful tips and recommendations, as well as information for efficient and trouble-free operation.

2 Product Description

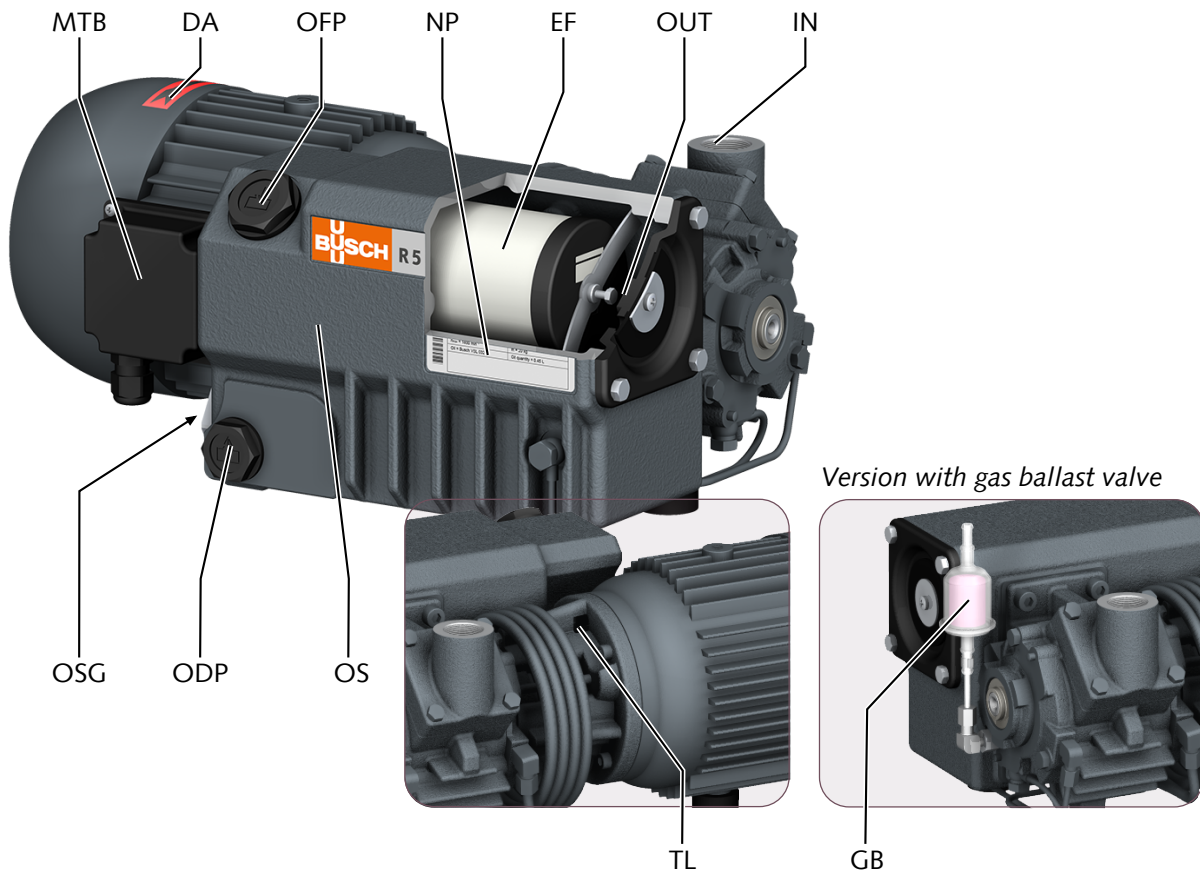

DA	Directional arrow	EF	Exhaust filter
GB	Gas ballast valve	IN	Suction connection
NP	Nameplate	MTB	Motor terminal box
ODP	Oil drain plug	OFP	Oil fill plug
OS	Oil separator	OSG	Oil sight glass
OUT	Discharge connection	TL	Transport lug

i NOTE

Technical term.

In this instruction manual, we consider that the term 'machine' refers to the 'vacuum pump'.

i NOTE

Illustrations

In this instruction manual the illustrations may differ from the machine appearance.

2.1 Operating Principle

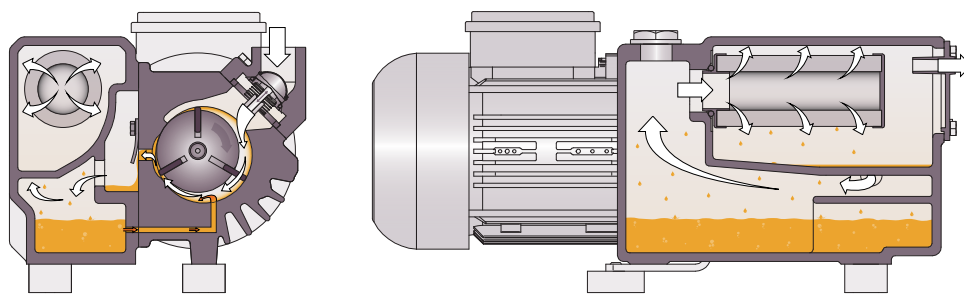

The machine works on the rotary vane principle.

The oil seals the gaps, lubricates the vanes and takes away compression heat.

Exhaust filters separate the oil from the discharged gas.

2.2 Application

The machine is intended for the suction of air and other dry, non-aggressive, non-toxic and non-explosive gases.

Conveying of other media leads to an increased thermal and/or mechanical load on the machine and is permissible only after a consultation with Busch.

The machine is intended for the placement in a non-potentially explosive environment.

The machine is designed for indoor installation, in case of outdoor installation, ask your Busch representative in order to take specific precautions.

The machine is capable of maintaining ultimate pressure, see Technical Data [► 22].

Depending on the version, the operating time of the machine can be limited as followed:

Machine version	Operating time
RB 0021 C	The machine is suitable for intermittent operation only. At the latest after 2 hours of continuous operation, the machine must be shut down for at least 15 minutes. Not to be used for continuous operation especially at rough vacuum .
RB 0021 C - with oil return line to the B-cover	The machine is suitable for continuous operation across the whole pressure range.
RC 0021 C – with oil return line to inlet flange.	The machine is suitable for continuous operation at rough vacuum.

Permitted environmental conditions, see Technical Data [► 22].

The machine is a built-in pump designed for vacuum packaging machines.

2.3 Optional Accessories

2.3.1 Gas Ballast Valve

The gas ballast valve mixes the process gas with a limited quantity of ambient air to counteract the condensation of vapour inside the machine.

The gas ballast valve has an influence on the ultimate pressure of the machine, see Technical Data [► 22].

2.3.2 Inlet Filter

The inlet filter protects the machine against dust and other solids in the process gas. The inlet filter is available with a paper or polyester cartridge.

2.3.3 Filter pressure gauge

Use the filter pressure gauge for checking the degree of clogging of the exhaust filter.

3 Transport



WARNING

Suspended load.

Risk of severe injury!

- Do not walk, stand or work under suspended loads.



NOTICE

In case the machine is already filled with oil.

Tilting a machine that is already filled with oil can cause large quantities of oil to ingress into the cylinder. Starting the machine with excessive quantities of oil in the cylinder will immediately break the vanes and ruin the machine!

- Drain the oil prior to every transport or always horizontally transport the machine.

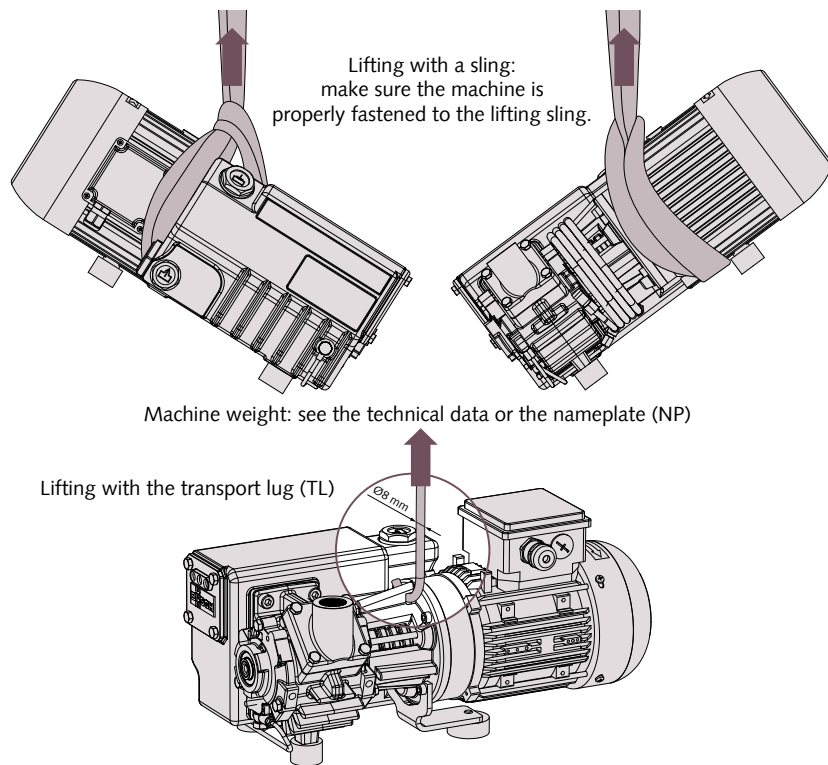

- Check the machine for transport damage.

If the machine is secured to a base plate:

- Remove the machine from the base plate.

4 Storage

- Seal all apertures with adhesive tape or reuse provided caps.

If the machine is to be stored for more than 3 months:

- Wrap the machine in a corrosion inhibiting film.
- Store the machine indoors, dry, dust free and if possible in original packaging preferably at temperatures between 0 ... 40 °C.

5 Installation

5.1 Installation Conditions

! NOTICE

Use of the machine outside of the permitted installation conditions.

Risk of premature failure!

Loss of efficiency!

- Take care that the installation conditions are fully complied with.

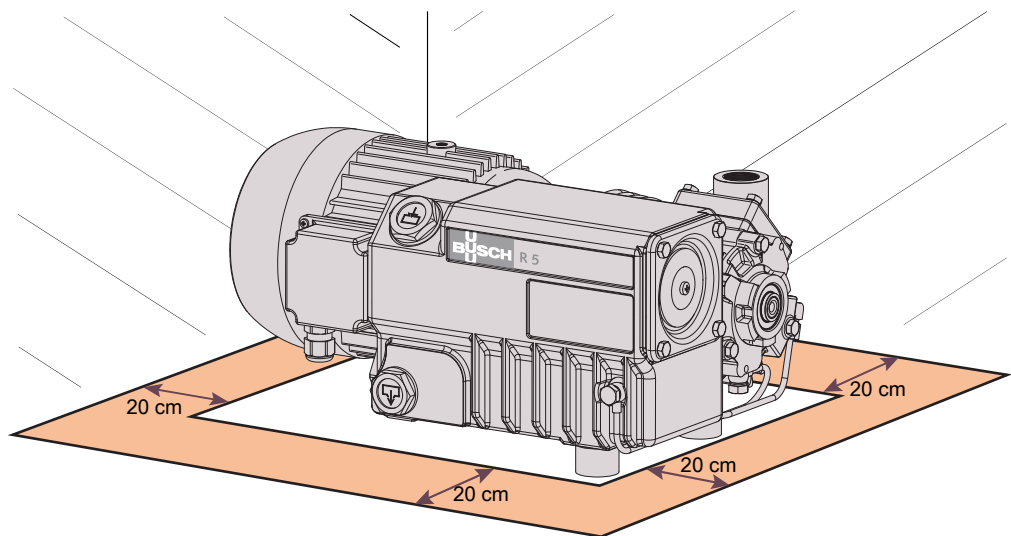

- Make sure that the environment of the machine is not potentially explosive.
- Make sure that the ambient conditions comply with the Technical Data [► 22].
- Make sure that the environmental conditions comply with the protection class of the motor and the electrical instruments.
- Make sure that the installation space or location is vented such that sufficient cooling of the machine is provided.
- Make sure that cooling air inlets and outlets are not covered or obstructed and that the cooling air flow is not affected adversely in any other way.
- Make sure that the oil sight glass (OSG) remains easily visible.
- Make sure that enough space remains for maintenance work.
- Make sure that the machine is placed or mounted horizontally, a maximum of 1° in any direction is acceptable.
- Check the oil level, see Oil Level Inspection [► 15].
- Make sure that all provided covers, guards, hoods, etc. are mounted.

If the machine is installed at an altitude greater than 1000 meters above sea level:

- Contact your Busch representative, the motor should be derated or the ambient temperature limited.

5.2 Connecting Lines / Pipes

- Remove all protective covers before installation.
- Make sure that the connection lines cause no stress on the machine's connection; if necessary use flexible joints.
- Make sure that the line size of the connection lines over the entire length is at least as large as the connections of the machine.

In case of very long connection lines it is advisable to use larger line sizes in order to avoid a loss of efficiency. Seek advice from your Busch representative.

5.2.1 Suction Connection

NOTICE

Ingress of foreign objects or liquids.

Risk of damage to the machine!

If the inlet gas contains dust or other foreign solid particles:

- Install a suitable filter (5 micron or less) upstream from the machine.

Connection size(s):

Depending on the specific order, other connection dimensions may apply.

5.2.2 Discharge Connection

CAUTION

The discharge gas contains small quantities of oil.

Risk to health!

If air is discharged into rooms where persons are present:

- Make sure that sufficient ventilation is provided.

Connection size(s):

Depending on the specific order, other connection dimensions may apply.

- Make sure that the discharged gas will flow without obstruction. Do not shut off or throttle the discharge line or use it as a pressurised air source.

Unless the aspirated air is discharged to the environment right at the machine:

- Make sure that the discharge line either slopes away from the machine or provide a liquid separator or a siphon with a drain cock, so that no liquids can flow back into the machine.

5.3 Filling Oil

! NOTICE

Use of an inappropriate oil.

Risk of premature failure!

Loss of efficiency!

- Only use an oil type which has previously been approved and recommended by Busch.

For oil type and oil capacity see Technical Data [► 22] and Oil [► 22].

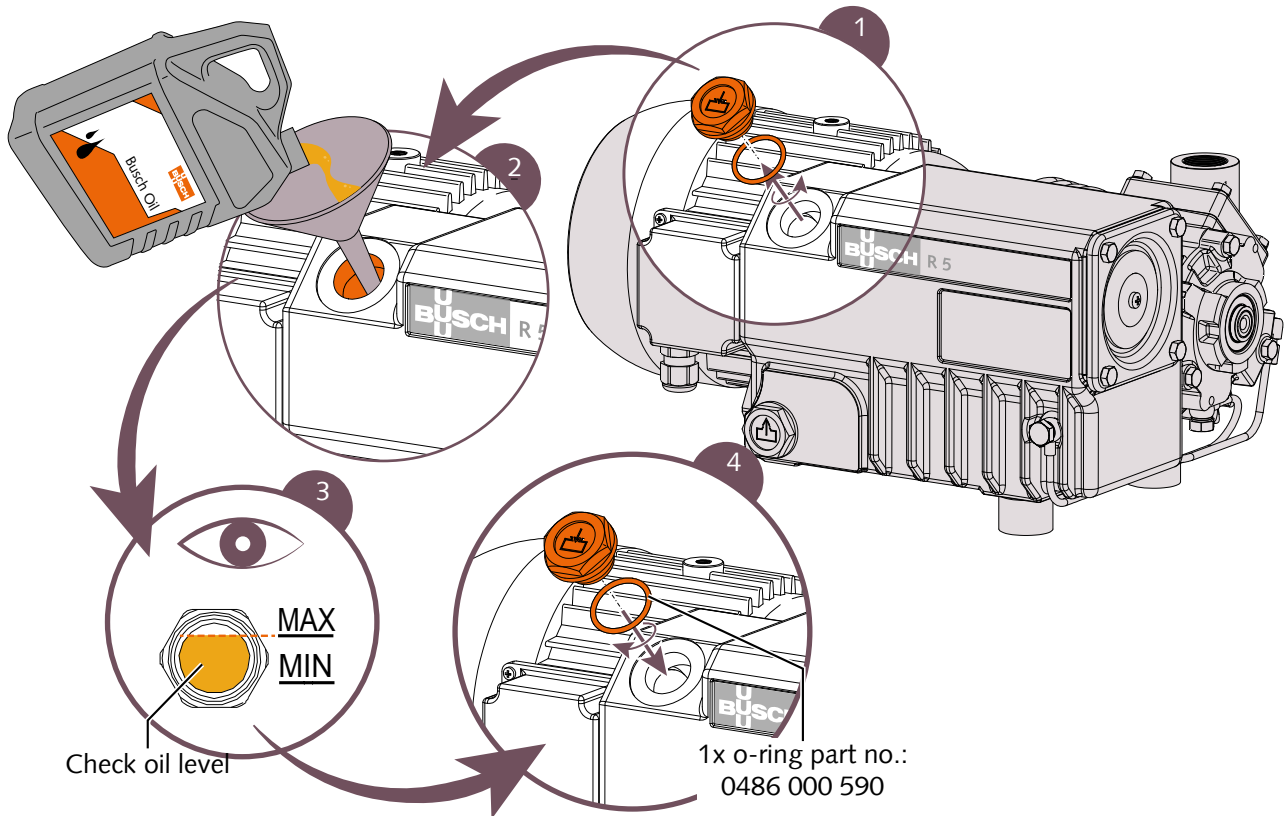

5.4 Electrical Connection

DANGER

Live wires.

Risk of electrical shock.

- Electrical installation work must only be executed by qualified personnel.
-
- Make sure that the power supply for the motor is compatible with the data on the nameplate of the motor.
 - The electrical installation must comply with applicable national and international standards.
 - Provide a lockable disconnect switch on the power line so that the machine is completely secured during maintenance tasks.
 - Provide an overload protection according to EN 60204-1 for the motor.
 - Busch recommends installing a D-curve circuit breaker.
 - Make sure that the motor of the machine will not be affected by electric or electro-magnetic disturbance from the mains; if necessary seek advice from Busch.
 - Connect the protective earth conductor.
 - Electrically connect the motor.

5.4.1 Wiring Diagram Single-Phase Motor

Connection Scheme of Alternating Current Motor

Explanation of color coding:

- BK = black
- BN = brown
- BU = blue
- GN = green
- RD = red
- YE = yellow

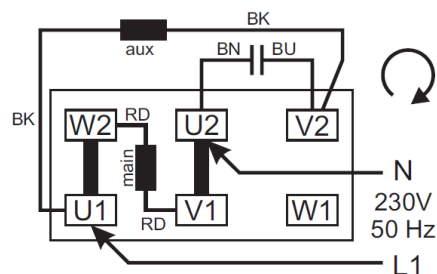

5.4.2 Wiring Diagram Three-Phase Motor

! NOTICE

Incorrect direction of rotation.

Risk of damage to the machine!

- Operation in the wrong direction of rotation can destroy the machine in a short time! Prior to start-up, ensure that the machine is operated in the right direction.
- Determine the intended direction of rotation with the arrow (stuck on or cast).
- Jog the motor briefly.
- Watch the fan wheel of the motor and determine the direction of rotation just before the fan wheel stops.

If the rotation of the motor must be changed:

- Switch any two of the motor phase wires.

Delta connection (low voltage):

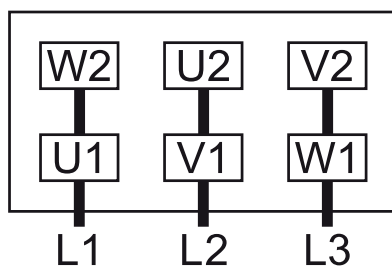

Star connection (high voltage):

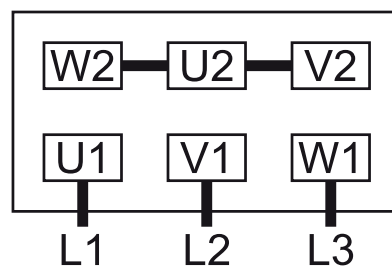

6 Commissioning

NOTICE

The machine can be shipped without oil.

Operation without oil will ruin the machine in short time!

- Prior to commissioning, the machine must be filled with oil, see Filling Oil [► 10].

CAUTION

During operation the surface of the machine may reach temperatures of more than 70°C.

Risk of burns!

- Avoid contact with the machine during and directly after operation.



CAUTION

Noise of running machine.

Risk of damage to hearing!

If persons are present in the vicinity of a non noise insulated machine over extended periods:

- Make sure that ear protection is being used.
- Make sure that the installation conditions (see Installation Conditions [► 8]) are met.
- Switch on the machine.
- Make sure that the maximum permissible number of starts does not exceed 12 starts per hour. Those starts should be spread within the hour.
- Make sure that the operating conditions comply with the Technical Data [► 22].
- After a few minutes of operation, check the oil level and top up if necessary.

As soon as the machine is operated under normal operating conditions:

- Measure the motor current and record it as reference for future maintenance and troubleshooting work.

6.1 Version with Oil Return Valve

During operation oil accumulates at the bottom of the upper chamber of the oil separator, which cannot flow down into the bottom chamber, as long as the machine runs.

After 2 hours of continuous operation, in case of high pressure difference between suction side and pressure side after a shorter period:

- Shut down the machine for at least 15 minutes.
- ⇒ The oil can run down from the upper chamber of the oil separator into the bottom chamber

6.2 Conveying Condensable Vapours

Water vapour within the gas flow is tolerated within certain limits. The conveyance of other vapours shall be agreed upon with Busch.

If condensable vapours are to be conveyed:

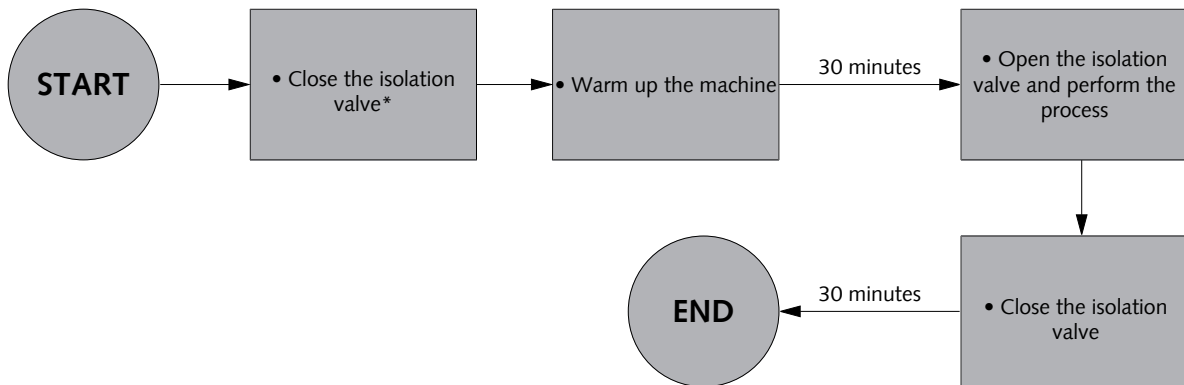

* not included in the scope of delivery

7 Maintenance



WARNING

Machines contaminated with hazardous material.

Risk of poisoning!

Risk of infection!

If the machine is contaminated with hazardous material:

- Wear appropriate personal protective equipment.

CAUTION

Hot surface.

Risk of burns!

- Prior to any action requiring touching the machine, let the machine cool down first.

NOTICE

Using inappropriate cleaners.

Risk of removing safety stickers and protective paint!

- Do not use incompatible solvents to clean the machine.

CAUTION

Failing to properly maintain the machine.

Risk of injuries!

Risk of premature failure and loss of efficiency!

- Respect the maintenance intervals or ask your Busch representative for service.

- Shut down the machine and lock against inadvertent start up.

- Vent the connected lines to atmospheric pressure.

If necessary:

- Disconnect all connections.

7.1 Maintenance Schedule

The maintenance intervals depend very much on the individual operating conditions. The intervals given below are desired to be considered as starting values which should be shortened or extended as appropriate. Particularly harsh applications or heavy duty operation, such as high dust loads in the environment or in the process gas, other contamination or ingress of process material, can make it necessary to shorten the maintenance intervals significantly.

Maintenance work	Interval	
	Normal application	Harsh application
<ul style="list-style-type: none"> Check the oil level, see Oil Level Inspection [► 15]. 	Daily	
<ul style="list-style-type: none"> Check the machine for oil leaks - in case of leaks have the machine repaired (contact Busch). In case an inlet filter is installed: <ul style="list-style-type: none"> Check the inlet filter cartridge, replace it if necessary. 	Monthly	
<ul style="list-style-type: none"> Contact Busch for an inspection. If required, overhaul the machine. 	Every 5 years	

* Service interval for synthetic oil, shorten the interval when using mineral oil, contact Busch Service

7.2 Oil Level Inspection

- Shut down the machine.
- When the machine is stopped, wait 1 minute before checking the oil level.



- Fill up if necessary, see Oil Filling [► 10].

7.3 Oil Change

! NOTICE

Use of an inappropriate oil.

Risk of premature failure!

Loss of efficiency!

- Only use an oil type which has previously been approved and recommended by Busch.

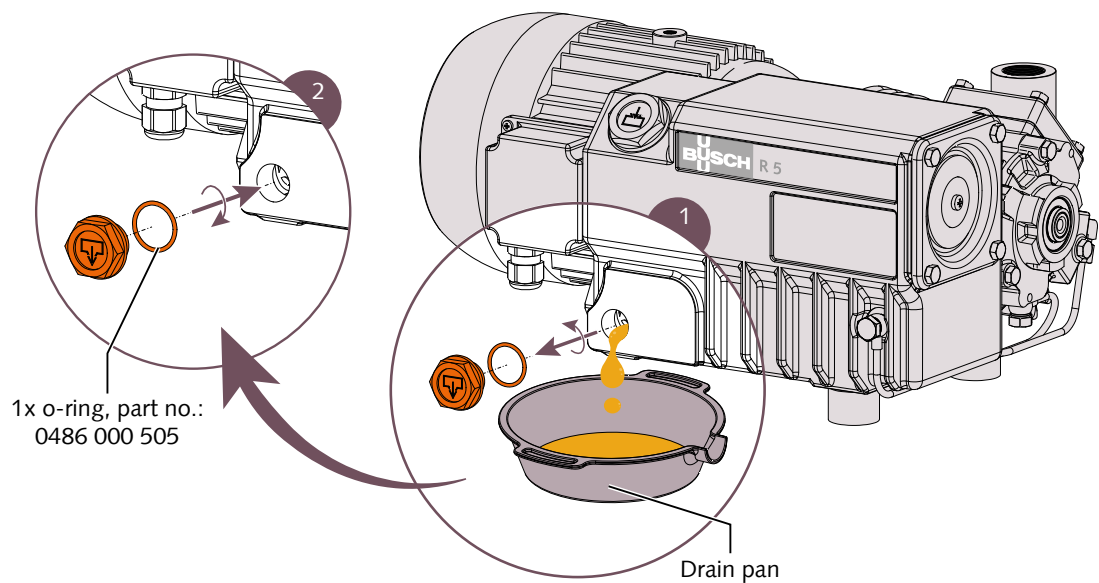

For oil type and oil capacity see Technical Data [► 22] and Oil [► 22].

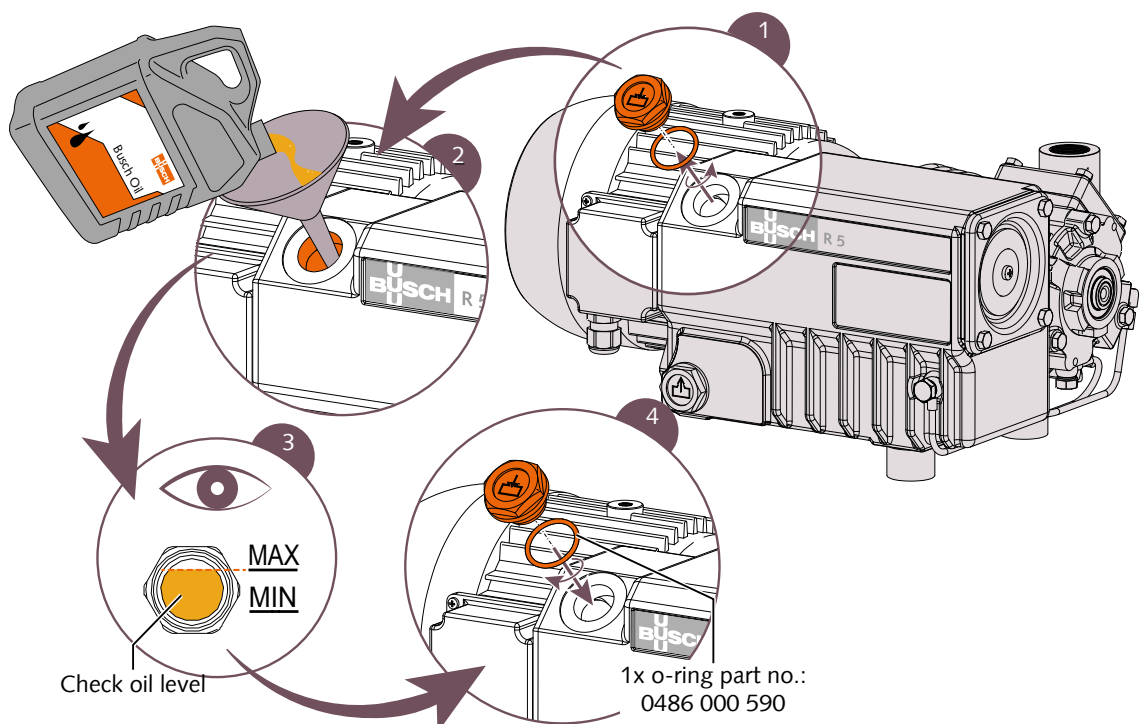

7.4 Exhaust Filter Change

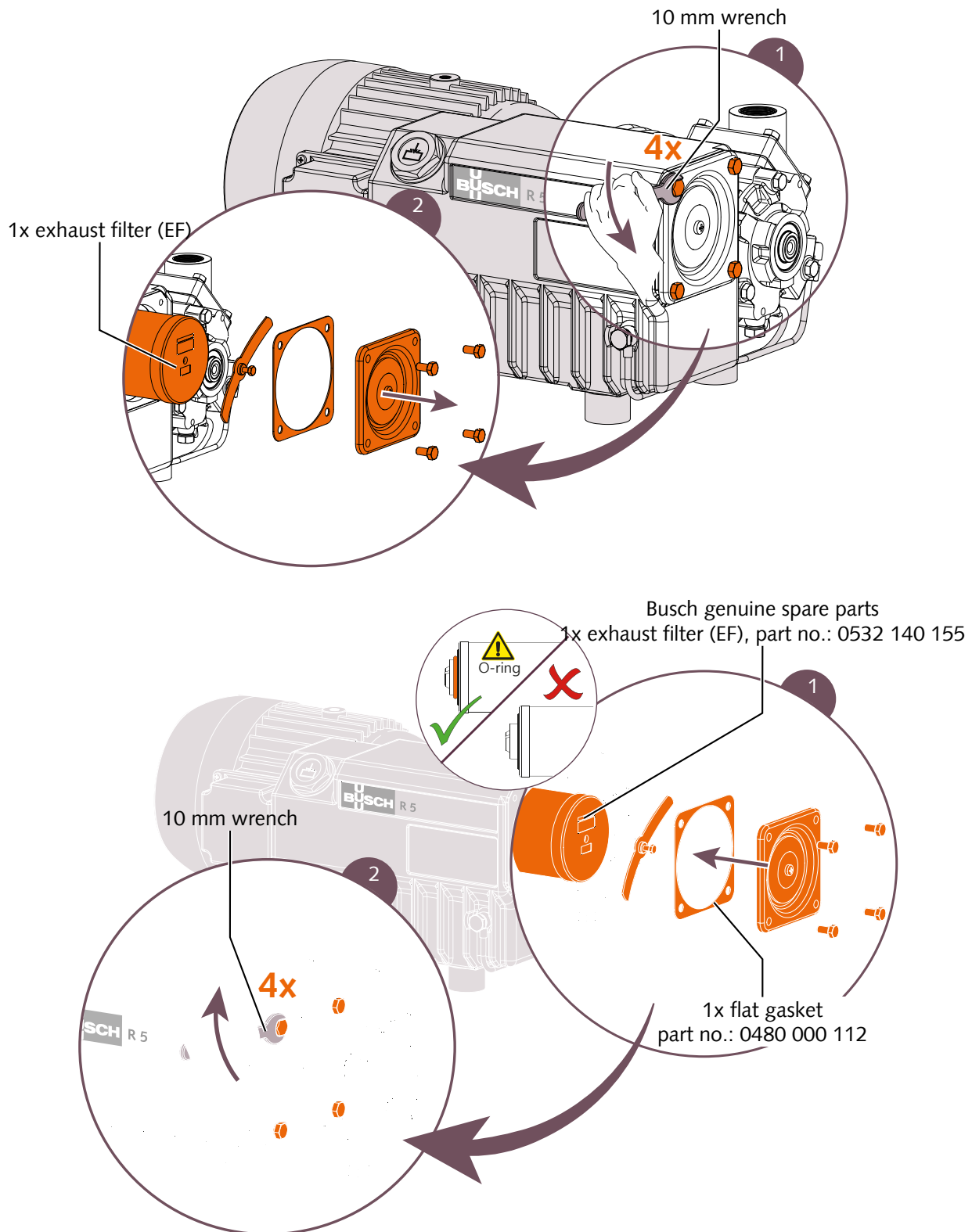

8 Overhaul

In case of the machine having conveyed gas that was contaminated with foreign materials which are dangerous to health:

- Decontaminate the machine as much as possible and state the contamination status in a 'Declaration of Contamination'.

Busch will only accept machines that come with a completely filled in and legally binding signed 'Declaration of Contamination'.

(Form downloadable from www.buschvacuum.com)

NOTICE

Improper assembly.

Risk of premature failure!

Loss of efficiency!

- It is highly recommended that any dismantling of the machine that goes beyond anything that is described in this manual should be done through Busch.



WARNING

Machines contaminated with hazardous material.

Risk of poisoning!

Risk of infection!

If the machine is contaminated with hazardous material:

- Wear appropriate personal protective equipment.

9 Decommissioning

- Shut down the machine and lock against inadvertent start up.
- Vent the connected lines to atmospheric pressure.
- Disconnect all connections.

If the machine is going to be stored:

- See Storage [► 7].

9.1 Dismantling and Disposal

- Drain the oil.
- Remove the exhaust filters.
- Remove the oil filter.
- Separate special waste from the machine.
- Dispose of special waste in compliance with applicable regulations.
- Dispose of the machine as scrap metal.

10 Spare Parts

NOTICE

Use of non-Busch genuine spare parts.

Risk of premature failure!

Loss of efficiency!

- The exclusive use of Busch genuine spare parts and consumables is recommended for the correct functioning of the machine and to validate the warranty.

Spare part kit	Description	Part no.
Service kit	Exhaust filter with O-ring Exhaust cover plate gasket Seal ring for oil fill plug Seal ring for oil drain plug	0992121241
Gasket kit	All seals	0990146959
Overhaul kit	Wearing parts Gasket kit	0993146964

If other parts are required:

- Contact your Busch representative for the detailed spare parts list.

11 Troubleshooting

 **DANGER**

Live wires.

Risk of electrical shock.

- Electrical installation work must only be executed by qualified personnel.

 **CAUTION**

Hot surface.

Risk of burns!

- Prior to any action requiring touching the machine, let the machine cool down first.

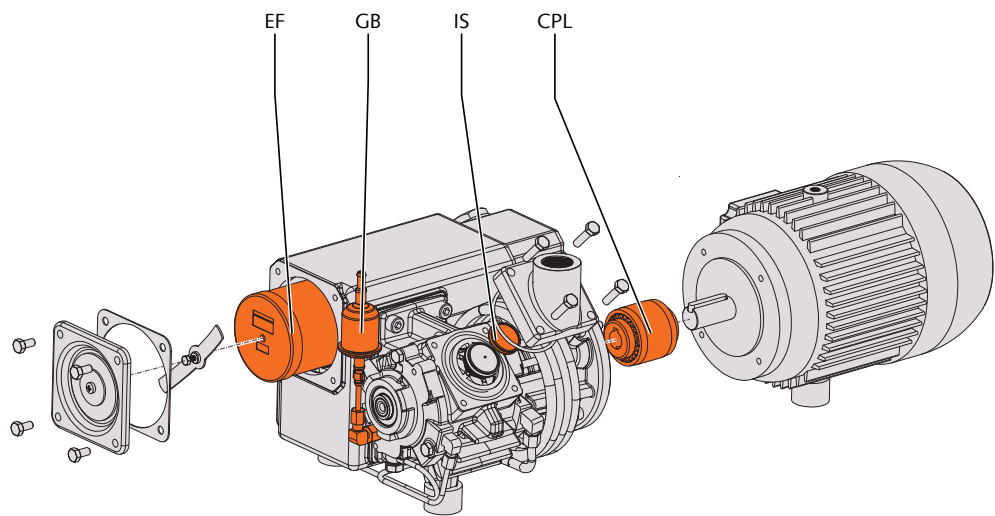

Problem	Possible Cause	Remedy
The machine does not start.	The motor is not supplied with the correct voltage.	• Check the power supply.
	The motor is defective.	• Replace the motor.
	The coupling (CPL) is defective.	• Replace the coupling (CPL).
The machine does not reach the usual pressure on the suction connection.	Oil level too low.	• Top up oil.
	The inlet screen (IS) is partially clogged.	• Clean the inlet screen (IS).
	The inlet filter cartridge (optional) is partially clogged.	• Replace the inlet filter cartridge.
	Internal parts are worn or damaged.	• Repair the machine (contact Busch).
The machine runs very noisily.	Worn coupling (CPL).	• Replace the coupling (CPL).
	Stuck vanes.	• Repair the machine (contact Busch).
	Defective bearings.	• Repair the machine (contact Busch).

The machine runs too hot.	Insufficient cooling.	<ul style="list-style-type: none"> Remove dust and dirt from the machine. Check the cooling fan.
	Ambient temperature too high.	<ul style="list-style-type: none"> Observe the permitted ambient temperature.
	Oil level too low.	<ul style="list-style-type: none"> Top up oil.
	The exhaust filters (EF) are partially clogged.	<ul style="list-style-type: none"> Replace the exhaust filters (EF).
The machine fumes or expels oil droplets through the gas discharge.	The exhaust filters (EF) are partially clogged.	<ul style="list-style-type: none"> Replace the exhaust filters (EF).
	An exhaust filter (EF) with o-ring is not fitted properly.	<ul style="list-style-type: none"> Ensure the correct position of the exhaust filters (EF) and the o-rings.
	The float valve (FV) does not work properly.	<ul style="list-style-type: none"> Check the float valve and the oil pipe for clogging. Remove the clogging.
	Version with oil return valve: The machine runs for more than 2 hours without interruption.	<ul style="list-style-type: none"> Regularly shut down the machine for short periods of time (see Version with Oil Return Valve [► 13]).
Abnormal oil consumption.	Oil leaks.	<ul style="list-style-type: none"> Replace seals (contact Busch).
	The float valve (FV) does not work properly.	<ul style="list-style-type: none"> Check float valve and the oil return line, repair it if necessary (contact Busch).
	The machine runs at atmospheric pressure for a long period.	<ul style="list-style-type: none"> Make sure that the machine operates under vacuum.
The oil is black.	Oil change intervals are too long.	<ul style="list-style-type: none"> Flush the machine (contact Busch).
	The inlet filter (optional) is defective.	<ul style="list-style-type: none"> Replace the inlet filter.
	The machine runs too hot.	<ul style="list-style-type: none"> See problem "The machine runs too hot".
The oil is emulsified.	The machine sucked in liquids or significant amounts of vapour.	<ul style="list-style-type: none"> Flush the machine (contact Busch). Clean the filter of the gas ballast valve (GB). Modify the operational mode (see Conveying Condensable Vapours [► 13]).

For the solution of problems not mentioned in the troubleshooting chart contact your Busch representative.

12 Technical Data

		RB 0021 C	RC 0021 C
Nominal pumping speed (50Hz / 60Hz)	m ³ /h	20 / 24	20 / 24
Ultimate pressure (without gas ballast valve)	hPa (mbar) abs.	2.0	20
Ultimate pressure (with gas ballast valve)	hPa (mbar) abs.	2.0	20
Nominal motor speed (50Hz / 60Hz)	min ⁻¹	3000 / 3600	
Nominal motor rating (50Hz / 60Hz)	kW	0.75 / 0.9	0.75 / 0.9
Power consumption at 100 mbar (50Hz / 60Hz)	kW	0.78 / 1.03	0.78 / 1.03
Power consumption at ultimate pressure (50Hz / 60Hz)	kW	0.56 / 0.79	0.7 / 0.9
Sound level (EN ISO 2151) (50Hz / 60Hz)	dB(A)	66 / 72	
Ambient temperature range	°C	See Oil [► 22]	
Ambient pressure		Atmospheric pressure	
Oil capacity	l	0.45	
Weight approx.	kg	~20	

13 Oil

	VM 068	VSA 068	VS8 068
ISO-VG	68	68	68
Oil type	Mineral oil	Synthetic oil	Synthetic oil
Ambient temperature range [°C]	5... 35	5... 40	5... 40
Part number 1 L packaging	0831 102 492	0831 163 964	0831 168 347
Part number 5 L packaging	0831 102 493	0831 163 965	0831 168 348

To know which oil has been filled in the machine, please refer to the nameplate (NP).