



INSTRUCTION MANUAL

MULTI-STAGE DRY VACUUM PUMP

MODEL EV-S20

MODEL EV-S50

MODEL EV-S100

MODEL EV-S200

CE / SEMI / NRTL MODEL

200-220V(50/60Hz)



Caution:

Please read and understand this INSTRUCTION MANUAL thoroughly before using this equipment.

Be sure to keep this INSTRUCION MANUAL on hand for future reference.

To Facility and Tool Manufactures:

Be sure to distribute this INSTRUCTION MANUAL to all end-user personnel actually operation this equipment.

「Model 000」 in this INSTRUCTION MANUAL is our model code.

ISSUED BY PRECISION MACHINERY COMPANY

The Products described herein fall under “the goods listed in row 16 of the appended table 1 of the Export Trade Control Order of Japan”, so in cases of export of such Products, you need to confirm “use” and “purchaser and/or end-user” and, as case may be, obtain the approval of the Minister of Economy, Trade and Industry. (Please confirm these conditions on your own.) For more information, please contact our sales office located near you.

Do not reproduce or reprint any portion of this manual without permission.
Manufacturer reserves the right to discontinue or change any specifications or designs without notice and without incurring obligations.
Model OOO in this catalog is our model code.

Environmental Basic Policies

It is our responsibility, as people of the earth, to protect nature's irreplaceable treasures and to pass them on to future generations.

As we undertake our business activities, we will establish environmental management systems and implement ongoing improvements and reviews, while striving to promote harmony between technology and nature, prevent environmental pollution, and improve the overall results of our environmental management activities. We are aware that environmental protection and management activities are the responsibility of all managers and employees of the Corporation, and each person will demonstrate this awareness when carrying out his or her duties.

We will widely publicize these basic policies to regional societies and the general public and work to make Ebara's position on the environment clear to society in general.

Safety Information

It is essential that those operating this pump should have the knowledge to identify and avoid hazardous conditions associated with the pump.

Inadequate or rash operation may cause dangerous and serious accidents.

Before installation and operation, the operator should first have a good knowledge of the pump construction, operation procedure, and its hazards.

The operator should read through this instruction manual and other documents issued by EBARA in detail.

If you have any questions on pump operation, safety, and maintenance, please do not hesitate to contact EBARA directly. Refer to Global network for contact address.

Three terms designating the level of hazard are used in this manual.



DANGER indicates an imminently hazardous situation which, if not avoided, will result in death or serious injury.



WARNING indicates a potentially hazardous situation which, if not avoided, could result in death or serious injury.



CAUTION indicates an imminently hazardous situation which, if not avoided, may result in minor or moderate injury.
This term may also be used as a warning for situations liable to damage to equipment.

[**NOTE**] The notes for the safe and proper handling of the product.

Important Prior Warnings



DANGER Keep out from under the pump when lifted.
Only qualified personnel shall unload and lift the pump.



WARNING Be careful not to overturn the pump when pushing and pulling it sideways, because the width of the pump is small to its height.



WARNING All electrical works must be performed by only a qualified electrician.
All national and local electrical regulations must be observed.



WARNING Circuit Breaker (CB) is not installed in the pump unit.
Please install Circuit Breaker (CB) based on the law and the standard in the installation region.



WARNING Interrupt Circuit Protector (CP) before starting on wiring and maintenance work.
Do not switch on the power supply to the pump until work is completed.



WARNING Supply N₂ gas to the exhaust piping when necessary to dilute the inflammable or toxic gas up to a safe concentration.



WARNING Purge with sufficient N₂ gas before removing and washing the vacuum and exhaust piping.
Do not let inflammable, toxic or dangerous materials disperse and guard against contact with the human body.
Always work in a location with an escape route in an emergency.



WARNING Do not use the pump for another process without a previous overhaul. Gases or reaction products remaining in the pump will react and lead to accidents with the formation of large amounts of products.



WARNING Check for gas leaks after installing and maintaining the piping. Gas leaks will result in the discharge of harmful and dangerous substances and in abnormal reactions due to the ingress of air into the pump. When checking for gas leaks by pressurization, please pressurize by less than 0.05 MPa into the purge port and do check.



WARNING Do not alter the pump member nor change any parts without the EBARA's consent or approval.



WARNING The pump casing and exhaust piping become extremely hot during operation and for some time after stopping. Be sure that pump and exhaust piping do not come in contact with humans or inflammable substances. Do not remove the pump cover during operation.



WARNING Check Safety Interlock functions periodically (every 6 months) to confirm the interlocks will work correctly.



CAUTION Disposal of process by-products shall be strictly in accordance with all local and national environmental and safety regulations.



CAUTION Disposal of Printed circuit board containing Lithium battery shall be strictly in accordance with all local and national environmental and applicable regulations.



WARNING In designing the dry pumps, Ebara does not assume risks caused by hazardous chemical reactions resulted from simultaneous injection or mixture of multiple process gases in the pumps, and the pump is not equipped with a protection against the dangers from such pump usage. The tool suppliers and users must pay attention not to simultaneously inject or mix those gases.



WARNING Do not perform a withstand voltage test.
Failure to comply could result in damage to the sensitive devices.



WARNING In MODEL EV-S20 type pump, the bolt which is fixing the lifting bracket to a pump is M6×12. This lifting bracket can use as fixing bracket. When you use this bracket as fixing bracket, you use M6×16 bolts for fixing this bracket to the lower side of the pump. When you use this bracket as lifting bracket, you cannot use the M6×16 bolts, because the M6×16 bolts reach to an internal part and have a possibility to break it.

- Using this bracket as a lifting bracket, please use the bolt of M6×12(hexagon head bolts).
- Using this bracket as a fixing bracket, please use the bolt of M6×16(hexagon head bolts).



CAUTION Never operate the pump without pump cover for safety.

Following safety warning labels are attached to pump covers.

1. High temperature warning
2. Hazardous voltage warning
3. Hazardous materials warning
4. Electric charge mark
5. Hazardous weight danger

1. High temperature warning

Hot surface may burn or cause injury.

Allow the piping and casing to cool before servicing.



2. Hazardous voltage warning

Hazardous Voltage may shock, burn, or cause death.

Turn power off and lockout before servicing.

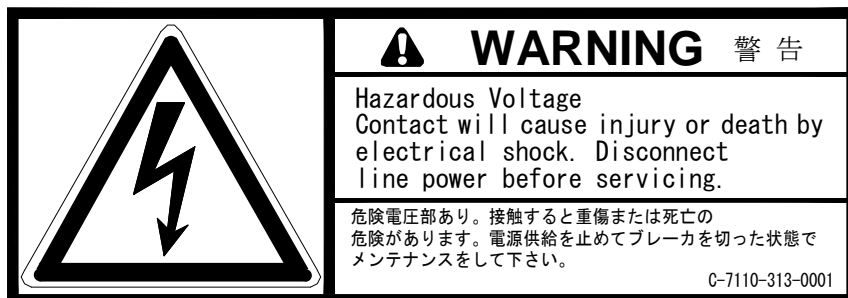

3. Hazardous materials warning

In case of hazardous materials are handled. Run the pump only with N₂ gas purge before servicing. Take adequate measures against dangerous reaction and contact with human body.



4. Electric charge mark

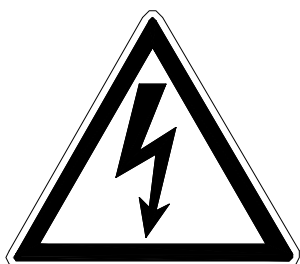

5. Hazardous weight danger

Heavy weight may cause severe injury or death due to overturning or falling pump. Keep out from under the lifted pump.
 Raise all adjuster-feet fully when moving.

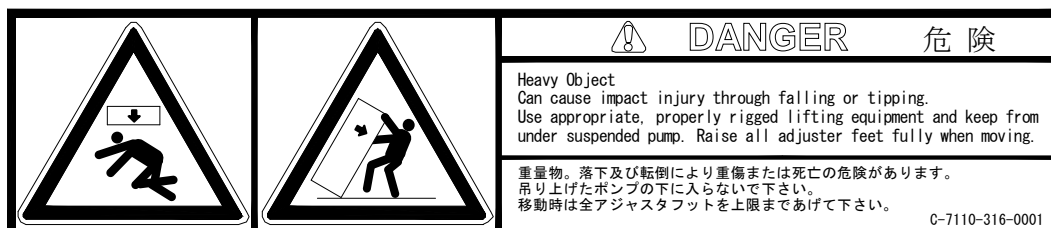

JGB-A2

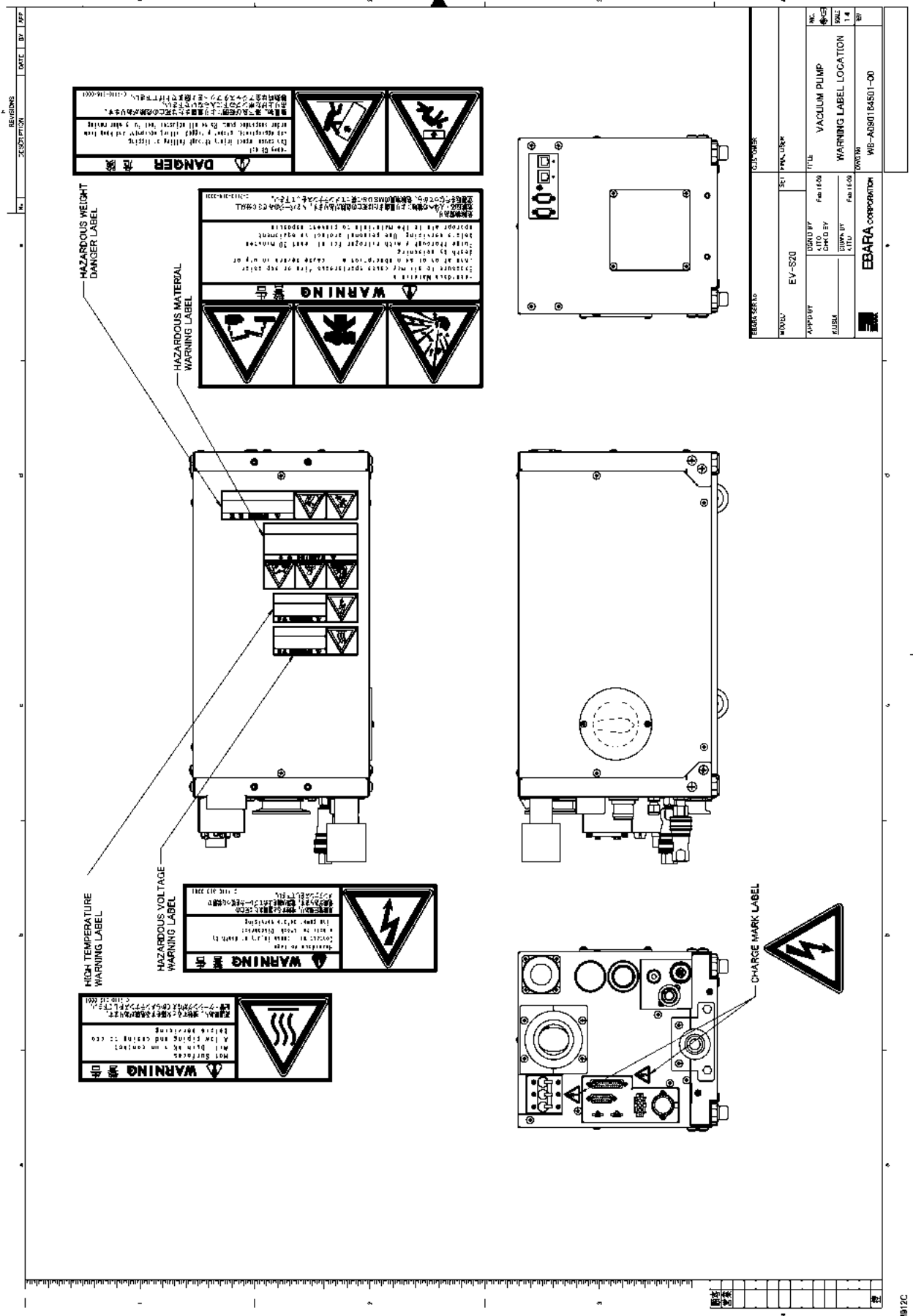

PM10U

JGB-A2

| REV. | DESCRIPTION | DATE | BY | APP. |
|------|-------------|------|----|------|
| | | | | |

HAZARDOUS VOLTAGE WARNING LABEL

WARNING

HAZARDOUS VOLTAGE
 1. Do not touch any exposed electrical parts.
 2. Do not touch any electrical parts when the unit is powered on.
 3. Do not touch any electrical parts when the unit is powered off.
 4. Do not touch any electrical parts when the unit is powered on or off.
 5. Do not touch any electrical parts when the unit is powered on or off.

HAZARDOUS MATERIAL WARNING LABEL

WARNING

HAZARDOUS MATERIAL
 1. Do not touch any exposed electrical parts.
 2. Do not touch any electrical parts when the unit is powered on.
 3. Do not touch any electrical parts when the unit is powered off.
 4. Do not touch any electrical parts when the unit is powered on or off.
 5. Do not touch any electrical parts when the unit is powered on or off.

HAZARDOUS WEIGHT
 DANGER LABEL

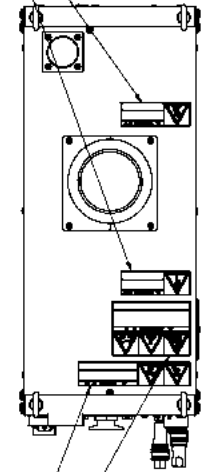

HAZARDOUS MATERIAL
 WARNING LABEL

HAZARDOUS MATERIAL WARNING LABEL

WARNING

HAZARDOUS MATERIAL
 1. Do not touch any exposed electrical parts.
 2. Do not touch any electrical parts when the unit is powered on.
 3. Do not touch any electrical parts when the unit is powered off.
 4. Do not touch any electrical parts when the unit is powered on or off.
 5. Do not touch any electrical parts when the unit is powered on or off.

HAZARDOUS WEIGHT DANGER LABEL

DANGER

HAZARDOUS WEIGHT
 1. Do not touch any exposed electrical parts.
 2. Do not touch any electrical parts when the unit is powered on.
 3. Do not touch any electrical parts when the unit is powered off.
 4. Do not touch any electrical parts when the unit is powered on or off.
 5. Do not touch any electrical parts when the unit is powered on or off.

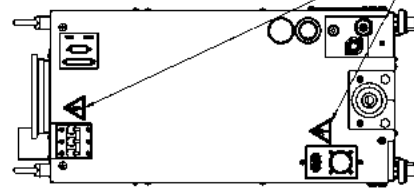
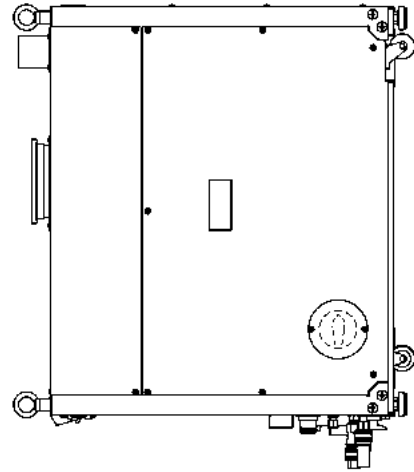
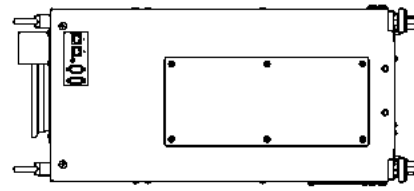

CHARGE MARK LABEL

| | | | |
|-------------|------|------------------------|------|
| EY-S200 | | TITLE | |
| DESIGNED BY | DATE | DESIGNED BY | DATE |
| APPROVED BY | DATE | APPROVED BY | DATE |
| REVISION | DATE | REVISION | DATE |
| EY-S200 | | TITLE | |
| VACUUM PUMP | | WARNING LABEL LOCATION | |
| EY-S200 | | TITLE | |
| EY-S200 | | TITLE | |

PMB12C

Safety Interlocks

**WARNING**

Check Safety Interlock functions periodically (every 6 months) to confirm the interlocks will work correctly.

NITROGEN FLOW LOW

A normally open flow switch breaks when nitrogen supply to the pump (oil bearing(s) and inter stage injection) drops below its factory set point, opening the motor starter relay(s) and shutting down the pump. Restoration of sufficient nitrogen flow permits restarting the pump.

MOTOR OVERLOAD

Motor thermostat protect the pump motor from overheating due to extended current draws in excess of the motor rating. Under a persistent overload condition, motor thermostat opens a contact, which interrupts the motor run circuit. A brief cool down interval permits restarting the pump.

Interlock Schematic (MODEL EV-S20)

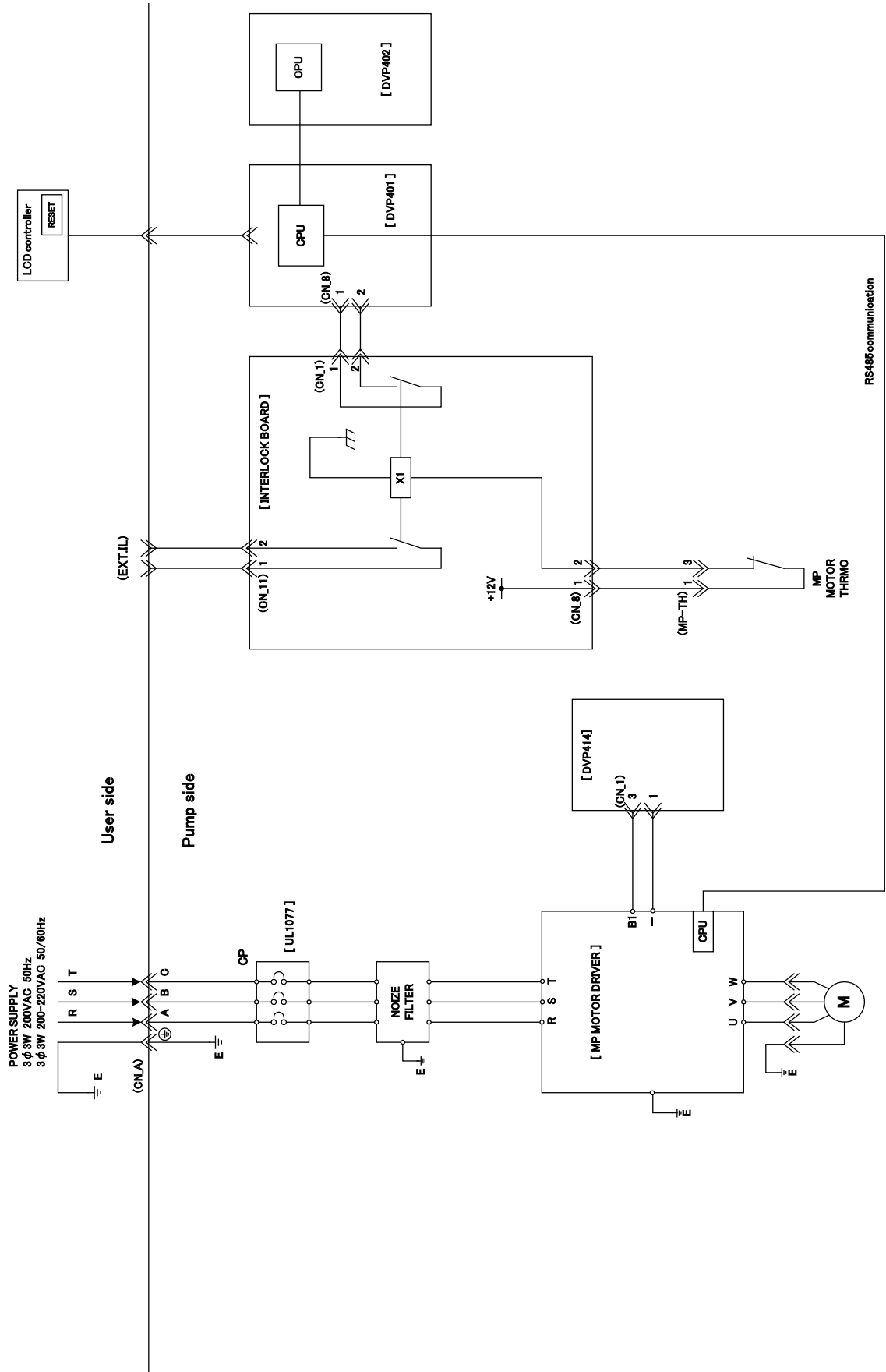

Interlock Schematic (MODEL EV-S50/ EV-S100/ EV-S200)

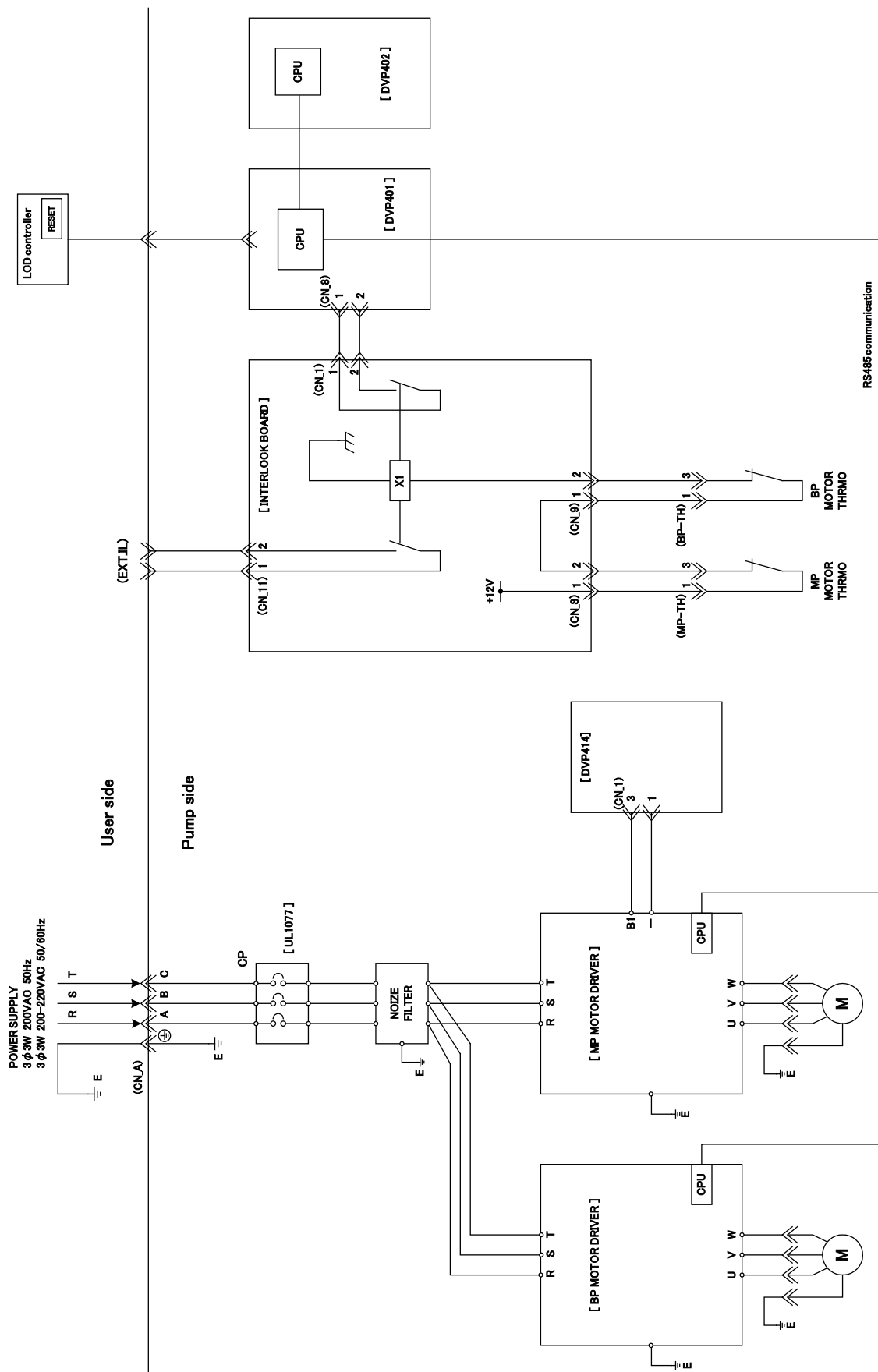

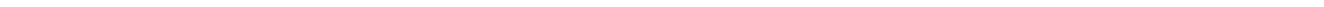

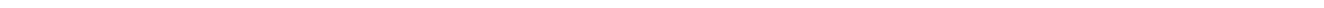
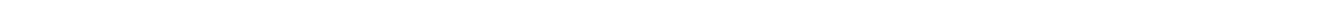

| | |
|---|-----------|
| MODEL EV-S100P / EV-S 100N OUTLINE DRAWING | 19 |
| MODEL EV-S200 OUTLINE DRAWING | 20 |
| MODEL EV-S200P / EV-S 200N OUTLINE DRAWING | 21 |
| MODEL EV-S20 OUTLINE DRAWING (OPTION) | 22 |
| MODEL EV-S20P / EV-S 20N OUTLINE DRAWING(OPTION)..... | 23 |
| MODEL EV-S50 OUTLINE DRAWING(OPTION) | 24 |
| MODEL EV-S50P / EV-S50N OUTLINE DRAWING(OPTION)..... | 25 |
| MODEL EV-S100 OUTLINE DRAWING(OPTION) | 26 |
| MODEL EV-S100P / EV-S 100N OUTLINE DRAWING(OPTION)..... | 27 |
| MODEL EV-S200 OUTLINE DRAWING(OPTION) | 28 |
| MODEL EV-S200P / EV-S 200N OUTLINE DRAWING(OPTION)..... | 29 |
| 3.5.4 Performance Curve | 30 |
| 4. Installation | 33 |
| 4.1 Movement and Fixation | 33 |
| 4.1.1 Location | 33 |
| 4.1.2 Caster and adjustment foot | 33 |
| 4.1.3 How to stack pumps | 34 |
| 4.1.4 Pump Fixation (Option) | 36 |
| 4.2 Piping | 41 |
| 4.2.1 Vacuum and Exhaust Piping | 41 |
| 4.2.2 Cooling Water Piping | 42 |
| 4.2.3 N ₂ Gas Piping | 43 |
| 4.2.4 Ventilation Duct (MODEL EV-S***N / MODEL EV-S***P) | 44 |
| 4.3 Electrical Wiring | 45 |
| 4.3.1 Power Supply Wiring | 46 |
| 4.3.2 Control Signal Wiring | 49 |
| 4.3.3 Emergency Stop Switch Box (EMS Switch Box) – Optional ... | 53 |
| 4.4 Safety interlock Connector (Connector EXT.IL) | 55 |
| 4.5 Power Supply for the Options (Connector CN-C) | 55 |
| 5. LCD Controller | 56 |
| 5.1 LCD Outline | 56 |
| 5.2 LCD Indication | 57 |
| 5.3 Setting the operational mode | 61 |
| 5.3.1 Setting the pump operation control mode | 63 |
| 5.3.2 Setting the DIP switch | 63 |
| 5.3.3 Setting the pump running mode | 64 |
| 5.3.4 Setting the rotational speed in the Normal mode | 64 |
| 5.3.5 Setting the rotational speed in the S. ENERGY mode | 65 |

| | | |
|-------|---|----|
| 5.3.6 | Setting the pump N2 flow low warning threshold | 65 |
| 5.3.7 | Setting the Back Pressure high warning threshold | 66 |
| 5.4 | Dip Switch | 67 |
| 5.5 | DIP Switch setting display | 70 |
| 5.6 | Starting/stopping the pump with the LCD controller..... | 71 |
| 6. | Operation | 72 |
| 6.1 | Before Starting | 72 |
| 6.2 | START/STOP | 75 |
| 6.2.1 | LOCAL (Pump Side) Start/Stop | 77 |
| 6.2.2 | REMOTE Start/Stop | 77 |
| 6.2.3 | COMMUNICATION Start/Stop | 78 |
| 6.3 | Operation when momentarily power failure happens..... | 78 |
| 7. | Maintenance and Inspection | 79 |
| 7.1 | Internal energies | 79 |
| 7.1.1 | Power source | 79 |
| 7.1.2 | Cooling water | 79 |
| 7.1.3 | Nitrogen gas | 79 |
| 7.2 | Routine Inspection | 80 |
| 7.3 | Vacuum and Exhaust Piping | 81 |
| 7.4 | Lubricating Oil | 83 |
| 7.5 | Spare (Maintenance) Parts List | 85 |
| 7.6 | List of wastes during maintenance | 86 |
| 7.7 | Overhaul | 86 |
| 8. | Disconnection and Transportation | 87 |
| 9. | For SEMI S2 standard | 89 |
| 10. | Troubleshooting | 90 |
| 10.1 | Troubleshooting (1) Basic trouble | 91 |
| 10.2 | Troubleshooting (2) WARNING | 92 |
| 10.3 | Troubleshooting (3) ALARM | 93 |
| 10.4 | Troubleshooting (4) Option | 94 |

1. Foreword

We appreciate that you have selected an EBARA Model EV-S series dry vacuum pumps. These pumps have been manufactured with much care and attention so that it can be operated safely and satisfactorily.

Incorrect operation will result in lack of performance and cause accidents and injuries to personnel.

[**NOTE**] This instruction manual contains all necessary information on operation and maintenance of the pump.

Be sure to operate the pump correctly in accordance with these instructions to ensure a long service life.

Keep this instruction manual in a suitable place for immediate reference whenever needed.

2. Introduction

2.1 Introduction

Check the following items on receipt of the pump package.

(1) Check that the nameplate affixed to the outer cover of the pump to confirm that the pump supplied agrees with your order.

Check the accessories against the packing list and the previously submitted drawings and documents to confirm that the all ordered accessories have been supplied.

(2) Check whether damage has occurred or screws/bolts have worked themselves loose in transit.



CAUTION Notify EBARA without delay when damage is discovered or when components are missing. Do not use when a leak is present as this will result in accident.

(3) Store the pump in a dry and clean place if it is not installed at once after delivery.

| | | |
|-------------|---|-------------|
| Temperature | : | 5-40°C |
| Humidity | : | 80% or less |

(4) Pump must be placed in an upright position.



CAUTION Do not stack the pump. Pump must be placed in an upright position. When the pump is overturned, lubricating oil inside a pump may leak to a rotor room, and it may cause trouble to operation.

2.2 Environmental Concerns

Handling or operating the unit other than specified may induce adverse impacts on the environment. Follow the descriptions below to handle, operate, and maintain the unit.

- (1) Ask an authorized waste-disposal company to dispose packing materials from uncrating according to laws and ordinances applicable to the waste.
- (2) Failure to do the unit maintenance (including overhaul) may trigger accidents causing injury or death, unit troubles, or environmental pollution. Plan the maintenance and perform it periodically to operate the unit efficiently.
- (3) To dispose the unit, follow effective laws and ordinances applicable in the area where the unit is installed.
- (4) To dispose the lubricant oil and chemicals, follow effective laws and ordinances applicable in the area where the unit is installed.



WARNING If the pump becomes damaged during shipment or if parts are missing, immediately contact EBARA. If a leaking or damaged product is used, an accident resulting in injury or death could occur or the product could become further damaged. Even if leakage occurs, take measures to ensure they will not be directly discharged from the site, as such leakage also wastes resources.



CAUTION If the product is not to be immediately installed, store it in a clean, dry location.

3. Product Description

3.1 Outline

These pumps have a compact design and includes various sensors and controls to enhance reliability and operation.

3.1.1 Pump Module

The pump is Roots type vacuum pump which rotates a pair of non-contact multi-stage rotors synchronized by timing gears.

The timing gears and bearings are enclosed in a compartment which is independent of the casing. For lubrication Perfluoro-Polyether (PFPE) oil and grease are used.

The pumps of this series are factory filled with lubrication oil. Use only the recommended lubrication oil grades shown in specification Table 3.1-3.4 for replenishing or replacing.

3.1.2 N₂ Gas (MODEL EV-S**P / MODEL EV-S**N)

Introduce nitrogen gas to dilute the hazardous gases to an unarmful level. Properly connect the nitrogen gas line to the purge port provided according to the instructions in Table 3.1 and the descriptions in Section 4.2.3. In the cases the gas concentration may become higher than the specified for safe gas exhaust, introduce the nitrogen gas to lines to the exhaust outlet. The tool user shall provide the purge port for this purpose.

N₂ gas is also required to supply to seal the shaft section. This protects the penetration to bearing section, such as corrosive gas. To reduce pump corrosion due to process gas or accumulation of reaction by-products, N₂ gas is supplied to each pump component as dilution purge gas. Stopping the dilution N₂ with a selector valve can save N₂ gas, when process does not produce corrosion and reaction by-products. The correct amount of N₂ gas is supplied for those two types of purge operation, by adjusting the regulation pressure to the specified value. The nitrogen gas selector is locating on the right side of the unit, facing the utility connectors. It is under the outer cover.

3.1.3 Cooling Water

Because the pump compresses gas from a vacuum to atmospheric pressure, compression heat is generated. Therefore cool the pump with cooling water.

The cooling water connector takes the form of a coupler for easy connection and disconnection.

3.1.4 Exhaust

A check valve is built into the pump unit to prevent reverse flow of gas from the exhaust through the pump to the vacuum chamber when pump is stopped.

3.2 Control System

These pumps have a built-in unit consisting of a Circuit Protector (CP), Noise Filter (NF), control source.

To improve reliability and safety, the condition of each utility and pump section is monitored by a sensor.

During pump operation all operating conditions are monitored, including power supply, cooling water flow, N₂ gas flow, casing and motor coil temperature, motor speed, and electric power for motor.

Continuous operation is possible when there is a momentarily power failure (170V or less) of 1 sec or less.

3.2.1 Warning

To assure the reliability of the pump as a vacuum exhaust system, the pump protection system generates two levels of alarm: WARNING and ALARM.

A WARNING signal is generated when pump operation exceeds the normal range. It therefore only draws attention that the normal operating values are not adhered to but does not signify that danger is imminent. The pump will continue to operate in this condition.

An ALARM signal output is generated and the pump will stop automatically when the upper mechanical safety limit is reached during pump operation.

When an ALARM output is suddenly generated, while the plant unit is operational, a WARNING signal will be generated to ensure that the plant operation is not discontinued. This enables the operator to check the pump after the equivalent of one cycle has been completed.

Be sure to contact EBARA Corporation for details on checking the WARNING and ALARM setting conditions.

3.2.2 Operation Status Control

The sensor data are displayed on the LCD provided on the controller to facilitate operation status control and daily inspection.

All WARNING and ALARM signals are displayed on the LCD. For remote operation and monitoring, the signals are available as individual and group outputs.

3.3 The way of pump moving

3.3.1 Preparation

Before pump moving, all adjuster feet shall be raised fully at four places.

In case of being not raised fully, pump may be tripped over by obstacle on floor.

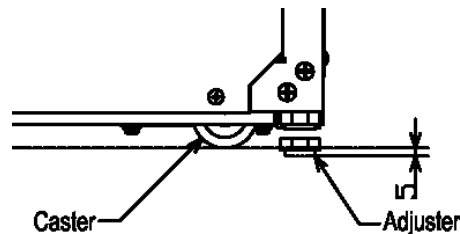

3.3.2 Moving method

Move pump slowly by pushing eye bolt toward direction A. Be sure not to be caught by toes. If pump needs to be moved toward direction B in order to be set at a corner or narrow spaces, two persons shall move the pump by pushing its terminal portion alternately as directed below.

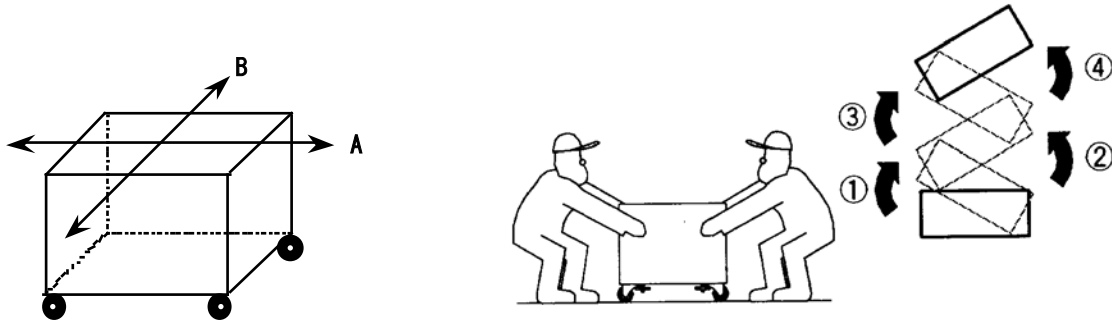

If pump needs to be moved on steps or ditches, spread steel plate or the like which can sustain the pump weight over the steps / ditches and pump shall be moved on it by two persons with care.

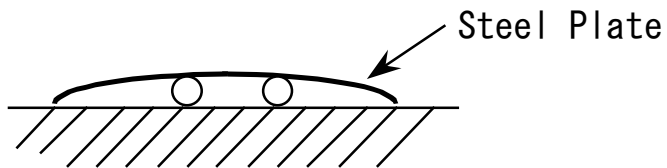

If pump should lose its balance when moving and start tripping over, never try to sustain the pump, get away from the pump immediately.

3.4 Release and shut off residual internal energy

**WARNING**

To avoid dangers potentially encountered during maintenance, transportation or storage, follow instructions below to shut off power.

**WARNING**

Capacitors within the control panel retain residual energy after interruption of power supply. Wait five (5) minutes after shutting off breaker before opening the control panel. Carefully check that bleed circuits have discharged the residual energy before servicing the control panel.

**WARNING**

To comply with SEMI S2, install lockable shutoff devices on electrical, nitrogen and cooling water supplies. These devices should be adjacent to and within sight of the pump.

3.4.1 Electrical Power - Lockout and Tagout

Lock the branch circuit in the OFF position and tag it out to perform maintenance or troubleshooting.

The Lockout/Tagout procedures must comply with OSHA 29 CFR 1910.147 and 1910.331-335

1. Turn off the pump circuit protector.
2. Turn the branch circuit disconnect off.
Check with a voltmeter that the power is shut off the pump.
3. Insert padlock through holes provided on locking device. Close padlock and attach tag. Keep the key with you while working.
4. Check that the LCD display is off.

3.4.2 Cooling water

1. Close [facility] water supply to stop water supply to the pump, then close water return valve. Follow [facility] procedures for locking these valves in the off position.
2. Push the knurled outer ring of the quick-connect couplers toward the pump to disconnect the water hoses. Carefully remove the male coupling valves from the hoses and remake the quick-connects to drain the pump lines. Have a catchment vessel and absorbent cloths at hand before removing the couplings.
3. Make sure water outflow stops from both the facility lines and the pump.

3.4.3 Nitrogen (N₂)

1. Close [facility] nitrogen supply valve and follow facility procedures for locking this valve in the off position.
2. Verify that the nitrogen pressure gauge (on front panel of the pump) drops to 0 MPa, confirming that no pressurized gas energy is stored in the pump.
3. Pull out the red detent ring on the N₂ regulator.
4. Turn knob counterclockwise until pressure gauge reads 0 MPa. (Both N₂ regulator knob and nitrogen pressure gauge are located on front panel of the pump.)
5. Disconnect tube connection of N₂ supply line by turning tube nut counterclockwise.
6. Plug (cap) ¼" tube connector on the pump with a tube fitting cap.

3.4.4 Returning to Service

1. Unlock and open water and nitrogen valves.
2. Remove handle stop bracket and switch circuit breaker on.
3. Restart pump and open foreline valve only after appropriate leak checks and safety verifications.

3.5 Detailed Specifications

The following tables and figures should be consulted for pump specification, dimension and performance details.

3.5.1 Model Description

EV – S 20 P

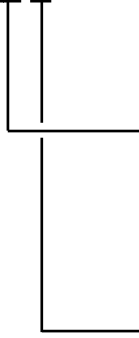

| Mark | Description |
|---------------------------|--|
| Pumping Speed | |
| 20 | 1670 L/min |
| 50 | 5000 L/min |
| 100 | 10000 L/min |
| 200 | 20000 L/min |
| Materials / N2 Purge Unit | |
| - | Standard / Without N2 purge unit |
| P | Standard / With N2 purge unit |
| N | Corrosion Resistant / With N2 purge unit |

3.5.2 Model Specifications

Table 3.1 Specifications (Model EV-S20 / EV-S20P / EV-S20N)

| Model | | Model EV-S20 | Model EV-S20P | Model EV-S20N | |
|--|------------------|--------------------------------|---|--|--|
| Pumping Speed | | 1670 L/min | | | |
| Ultimate Pressure | | 3.0 Pa | 5.0 Pa | | |
| Connection | Gas Inlet | NW50 | | | |
| | Gas Outlet | NW25 | | | |
| Approx. Power at Ultimate Pressure (Max. Power) | | 0.4 kW (2.2 kW) | | | |
| Utility | Cooling Water | Connection | Rc 1/4" (Coupler) | | |
| | | Pressure [Gauge Press.] | Differential Press.: Min. 0.2 MPa Supply: Max. 0.4 MPa | | |
| | | Flow Rate | 1.5 - 3.0 L/min | | |
| | | Temperature | Max. 30°C | | |
| | N2 Gas | Connection | ----- | 1/4" Tube Fitting (Same as SWAGELOK) | |
| | | Pressure [Gauge Press.] | ----- | Supply: 0.15 - 0.7 MPa [Setting: 0.09 - 0.012 MPa] | |
| | | Approx. Flow Rate [N2-0 Mode] | ----- | 17 - 20 Pa m ³ /s [2.4 Pa m ³ /s] | |
| | Duct Ventilation | Connection | ----- | Φ50 mm | |
| | | Pressure | ----- | -196 Pa | |
| | | Approx. Flow Rate | ----- | 0.5 m ³ /min | |
| | Lubrication Oil | Brand | BARRIERTA J100ES (NOK) | | |
| | | Quantity | 0.05 L | | |
| Approx. Weight | | 60 kg | | | |
| Power Supply | Phase/Volt/Freq. | 3 Phase, 200-220V , 50 / 60Hz | | | |
| | Power Capacity | 3.2 kVA | | | |
| | Connection | Amphenol C016 20C003 100 12 | | | |
| Control Signal | | D-sub 15 Pin + D-sub 25 Pin | | | |
| Communication | | RS-232C D-sub 9 Pin X 2 | | | |
| CP Rating | | 15 A | | | |
| SCCR | | 1.0 kA | | | |
| Airborne noise test data | | 57 dB | | | |
| Max inlet pressure / Flow Rate (N ₂) (for reference) | | 4.2kPa / 60L/min | | 2.7kPa / 40L/min | |

[Note] The ambient temperature of the pump installation place shall be 30 degrees of centigrade of lower.

Table 3.2 Specifications (Model EV-S50 / EV-S50P / EV-S50N)

| Model | | Model EV-S50 | Model EV-S50P | Model EV-S50N | |
|--|------------------|---|---|--|--|
| Pumping Speed | | 5000 L/min | | | |
| Ultimate Pressure | | 0.5 Pa | | | |
| Connection | Gas Inlet | NW50 | | | |
| | Gas Outlet | NW25 | | | |
| Approx. Power at Ultimate Pressure (Max. Power) | | 0.55 kW (3.6 kW) | | | |
| Utility | Cooling Water | Connection | Rc 1/4" (Coupler) | | |
| | | Pressure [Gauge Press.] | Differential Press.: Min. 0.2 MPa Supply: Max. 0.4 MPa | | |
| | | Flow Rate | 2.0 - 3.0 L/min | | |
| | | Temperature | Max. 30°C | | |
| | N2 Gas | Connection | ----- | 1/4" Tube Fitting (Same as SWAGELOK) | |
| | | Pressure [Gauge Press.] | ----- | Supply: 0.15 - 0.7 MPa [Setting: 0.09 - 0.012 MPa] | |
| | | Approx. Flow Rate [N2-0 Mode] | ----- | 17 - 20 Pa m ³ /s [2.4 Pa m ³ /s] | |
| | Duct Ventilation | Connection | ----- | Φ50 mm | |
| | | Pressure | ----- | -196 Pa | |
| | | Approx. Flow Rate | ----- | 0.5 m ³ /min | |
| Lubrication Oil | Brand | BARRIERTA J100ES (NOK) | | | |
| | Quantity | 0.1 L | | | |
| Approx. Weight | | 100 kg | | | |
| Power Supply | Phase/Volt/Freq. | 3 Phase, 200-220V , 50 / 60Hz | | | |
| | Power Capacity | 4.8 kVA | | | |
| | Connection | Japan Aviation Electronics Industry JL04HV-2E22-22PE-B-R | | | |
| Control Signal | | D-sub 15 Pin + D-sub 25 Pin | | | |
| Communication | | RS-232C D-sub 9 Pin X 2 | | | |
| CP Rating | | 20 A | | | |
| SCCR | | 1.0 kA | | | |
| Airborne noise test data | | 57 dB | | | |
| Max inlet pressure / Flow Rate (N ₂) (for reference) | | 1.0kPa / 50L/min | | 0.7kPa / 35L/min | |

[Note] The ambient temperature of the pump installation place shall be 30 degrees of centigrade of lower.

Table 3.3 Specifications (Model EV-S100 / EV-S100P / EV-S100N)

| Model | | Model EV-S100 | Model EV-S100P | Model EV-S100N | |
|--|------------------|---|---|--|--|
| Pumping Speed | | 10000 L/min | | | |
| Ultimate Pressure | | 0.5 Pa | | | |
| Connection | Gas Inlet | NW80 | | | |
| | Gas Outlet | NW40 | | | |
| Approx. Power at Ultimate Pressure (Max. Power) | | 0.65 kW (4.6 kW) | | | |
| Utility | Cooling Water | Connection | Rc 1/4" (Coupler) | | |
| | | Pressure [Gauge Press.] | Differential Press.: Min. 0.2 MPa Supply: Max. 0.4 MPa | | |
| | | Flow Rate | 2.0 - 3.0 L/min | | |
| | | Temperature | Max. 30°C | | |
| | N2 Gas | Connection | ----- | 1/4" Tube Fitting (Same as SWAGELOK) | |
| | | Pressure [Gauge Press.] | ----- | Supply: 0.15 - 0.7 MPa [Setting: 0.09 - 0.012 MPa] | |
| | | Approx. Flow Rate [N2-0 Mode] | ----- | 17 - 20 Pa m ³ /s [2.4 Pa m ³ /s] | |
| | Duct Ventilation | Connection | ----- | Φ50 mm | |
| | | Pressure | ----- | -196 Pa | |
| | | Approx. Flow Rate | ----- | 0.5 m ³ /min | |
| Lubrication Oil | Brand | BARRIERTA J100ES (NOK) | | | |
| | Quantity | 0.1 L | | | |
| Approx. Weight | | 120 kg | | | |
| Power Supply | Phase/Volt/Freq. | 3 Phase, 200-220V , 50 / 60Hz | | | |
| | Power Capacity | 6.4 kVA | | | |
| | Connection | Japan Aviation Electronics Industry JL04HV-2E22-22PE-B-R | | | |
| Control Signal | | D-sub 15 Pin + D-sub 25 Pin | | | |
| Communication | | RS-232C D-sub 9 Pin X 2 | | | |
| CP Rating | | 30 A | | | |
| SCCR | | 1.0 kA | | | |
| Airborne noise test data | | 57 dB | | | |
| Max inlet pressure / Flow Rate (N ₂) (for reference) | | 0.65kPa / 50L/min | | 0.4kPa / 35L/min | |

[Note] The ambient temperature of the pump installation place shall be 30 degrees of centigrade of lower.

Table 3.4 Specifications (Model EV-S200 / EV-S200P / EV-S200N)

| Model | | Model EV-S200 | Model EV-S200P | Model EV-S200N | |
|--|------------------|---|---|--|--|
| Pumping Speed | | 20000 L/min | | | |
| Ultimate Pressure | | 0.5 Pa | | | |
| Connection | Gas Inlet | NW100 | | | |
| | Gas Outlet | NW40 | | | |
| Approx. Power at Ultimate Pressure (Max. Power) | | 0.75 kW (5.1 kW) | | | |
| Utility | Cooling Water | Connection | Rc 1/4" (Coupler) | | |
| | | Pressure [Gauge Press.] | Differential Press.: Min. 0.2 MPa Supply: Max. 0.4 MPa | | |
| | | Flow Rate | 2.0 - 3.0 L/min | | |
| | | Temperature | Max. 30°C | | |
| | N2 Gas | Connection | ----- | 1/4" Tube Fitting (Same as SWAGELOK) | |
| | | Pressure [Gauge Press.] | ----- | Supply: 0.15 - 0.7 MPa [Setting: 0.09 - 0.012 MPa] | |
| | | Approx. Flow Rate [N2-0 Mode] | ----- | 17 - 20 Pa m ³ /s [2.4 Pa m ³ /s] | |
| | Duct Ventilation | Connection | ----- | Φ50 mm | |
| | | Pressure | ----- | -196 Pa | |
| | | Approx. Flow Rate | ----- | 0.5 m ³ /min | |
| | Lubrication Oil | Brand | BARRIERTA J100ES (NOK) | | |
| | | Quantity | 0.15 L | | |
| Approx. Weight | | 170 kg | | | |
| Power Supply | Phase/Volt/Freq. | 3 Phase, 200-220V , 50 / 60Hz | | | |
| | Power Capacity | 6.8 kVA | | | |
| | Connection | Japan Aviation Electronics Industry JL04HV-2E22-22PE-B-R | | | |
| Control Signal | | D-sub 15 Pin + D-sub 25 Pin | | | |
| Communication | | RS-232C D-sub 9 Pin X 2 | | | |
| CP Rating | | 30 A | | | |
| SCCR | | 1.0 kA | | | |
| Airborne noise test data | | 63 dB | | | |
| Max inlet pressure / Flow Rate (N ₂) (for reference) | | 0.08kPa / 15L/min | | 0.08kPa / 15L/min | |

[Note] The ambient temperature of the pump installation place shall be 30 degrees of centigrade of lower.

3.5.3 Outline Drawing

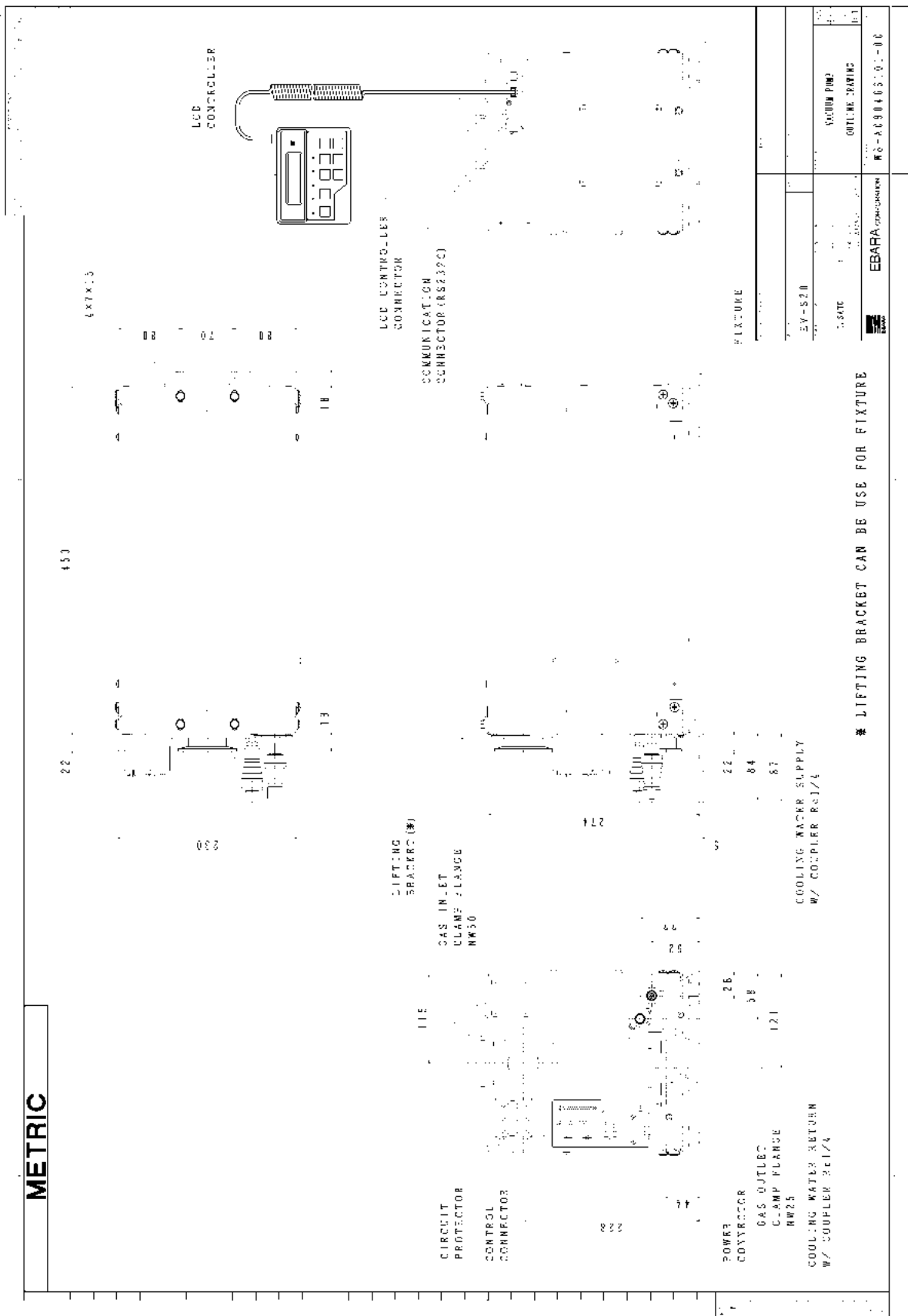

METRIC

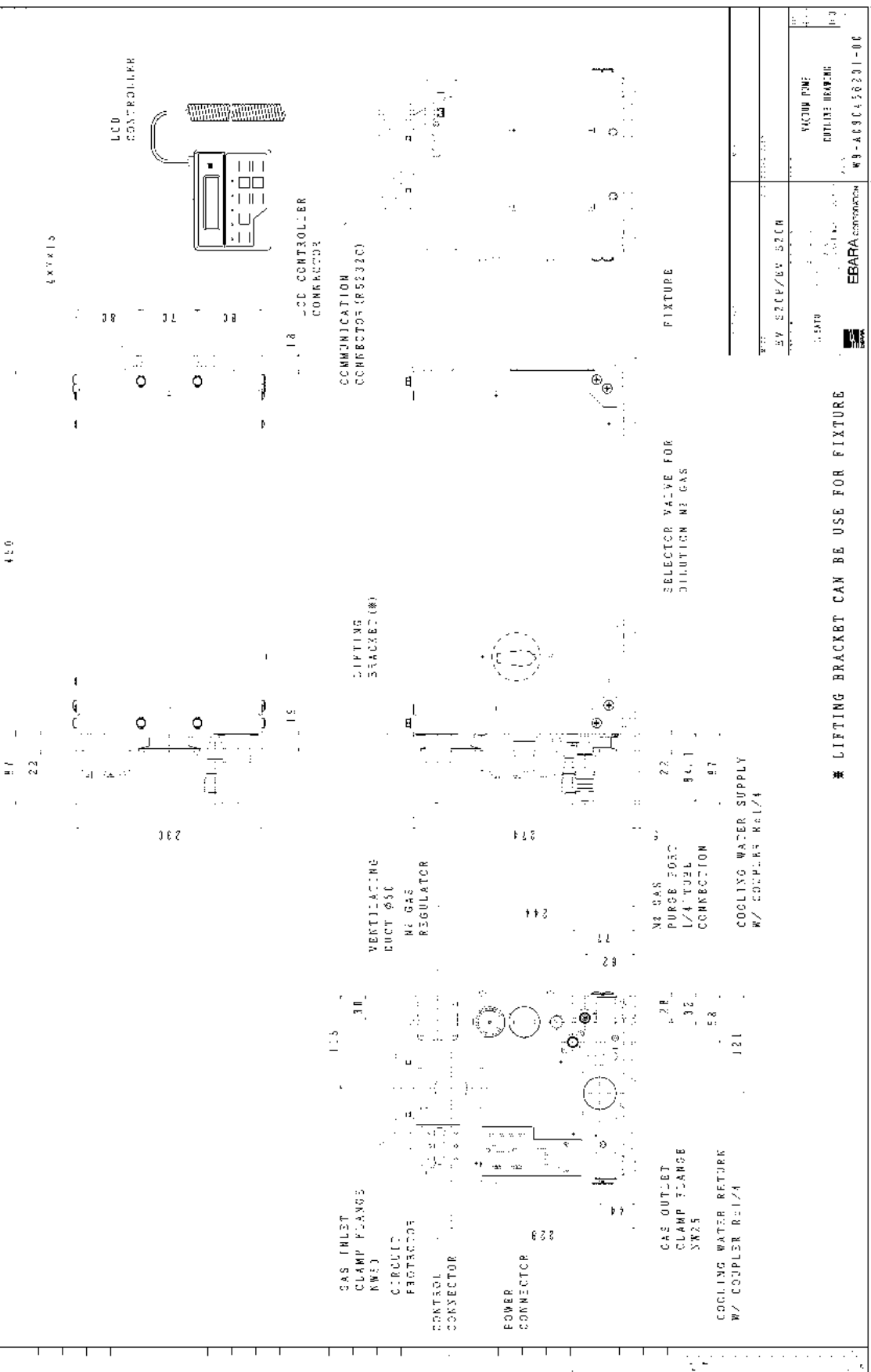

* LIFTING BRACKET CAN BE USE FOR FIXTURE

| | | | |
|---------------------------|---------|---|-----------------------|
| BY: S21P/UV S2CH | | DATE: 2013/05/20 | |
| NO: 1519 | REV: 01 | PROJECT: VACUUM PUMP | ITEM: OUTLINE DRAWING |
| | | EBARA CORPORATION NO. 4-1-1, SHIMIZU 2-CHOME, YAMATE-KU, KYOTO 604-8586, JAPAN TEL: 81-75-821-1111 FAX: 81-75-821-1112 WWW.EBARA.COM | |
| PART NO: W9-A080430201-00 | | | |

METRIC

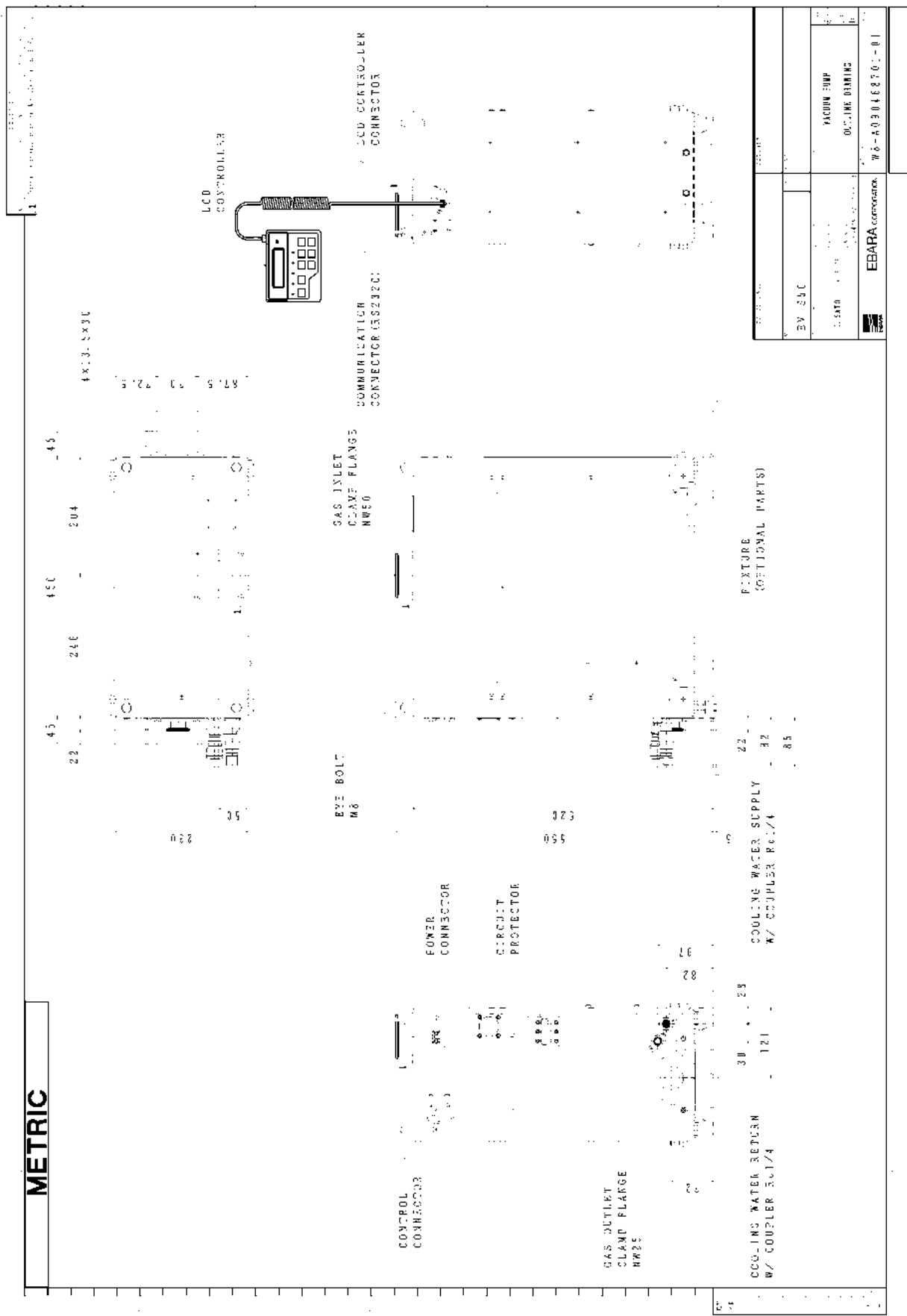

| | | | |
|-------------------|--|-------------------|--|
| EQUIPMENT | | PARTS | |
| BV 24C | | VACUUM PUMP | |
| LSNR | | OIL-LINE DRAINING | |
| EBARA Corporation | | W6-A03046870-01 | |

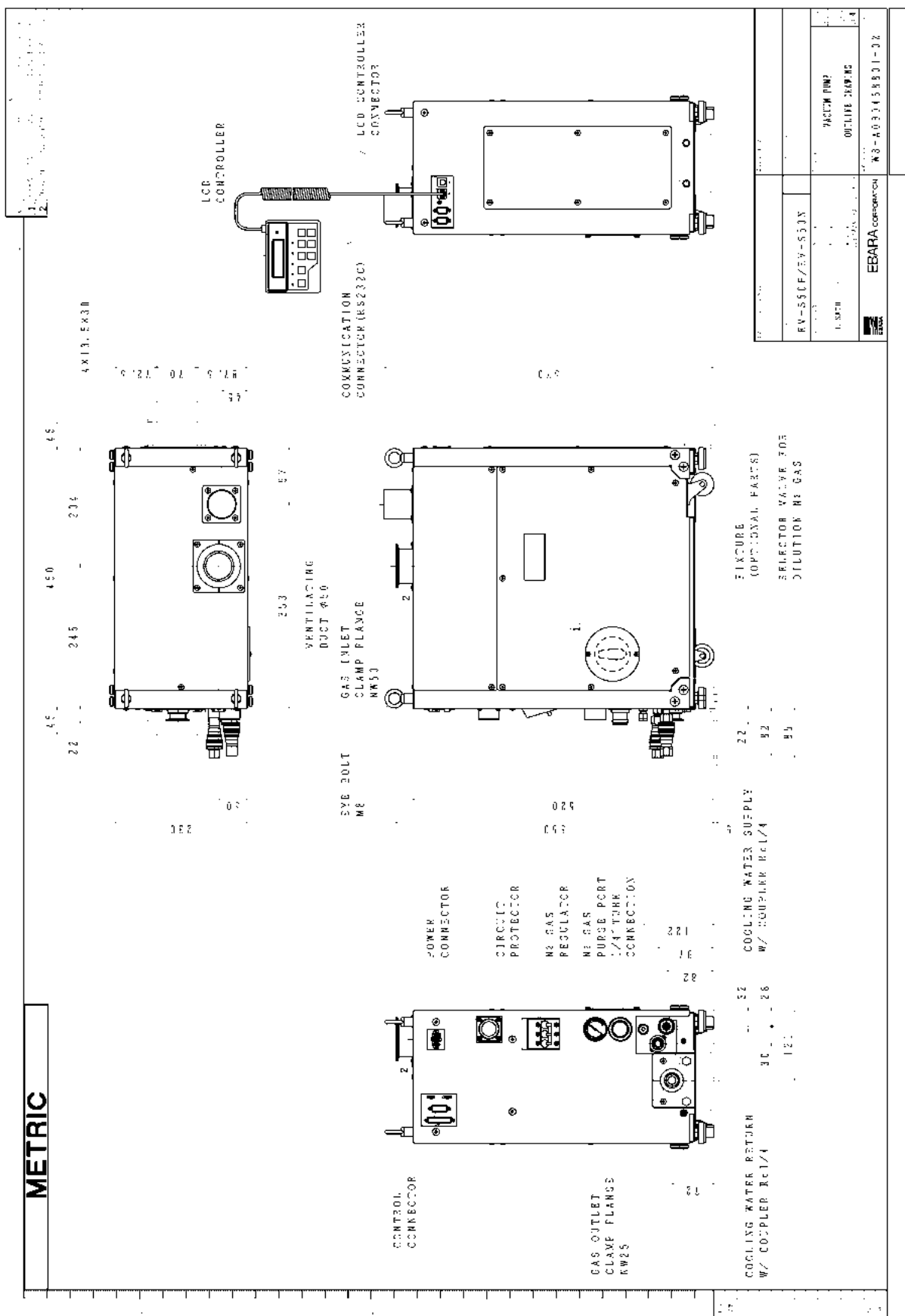

METRIC

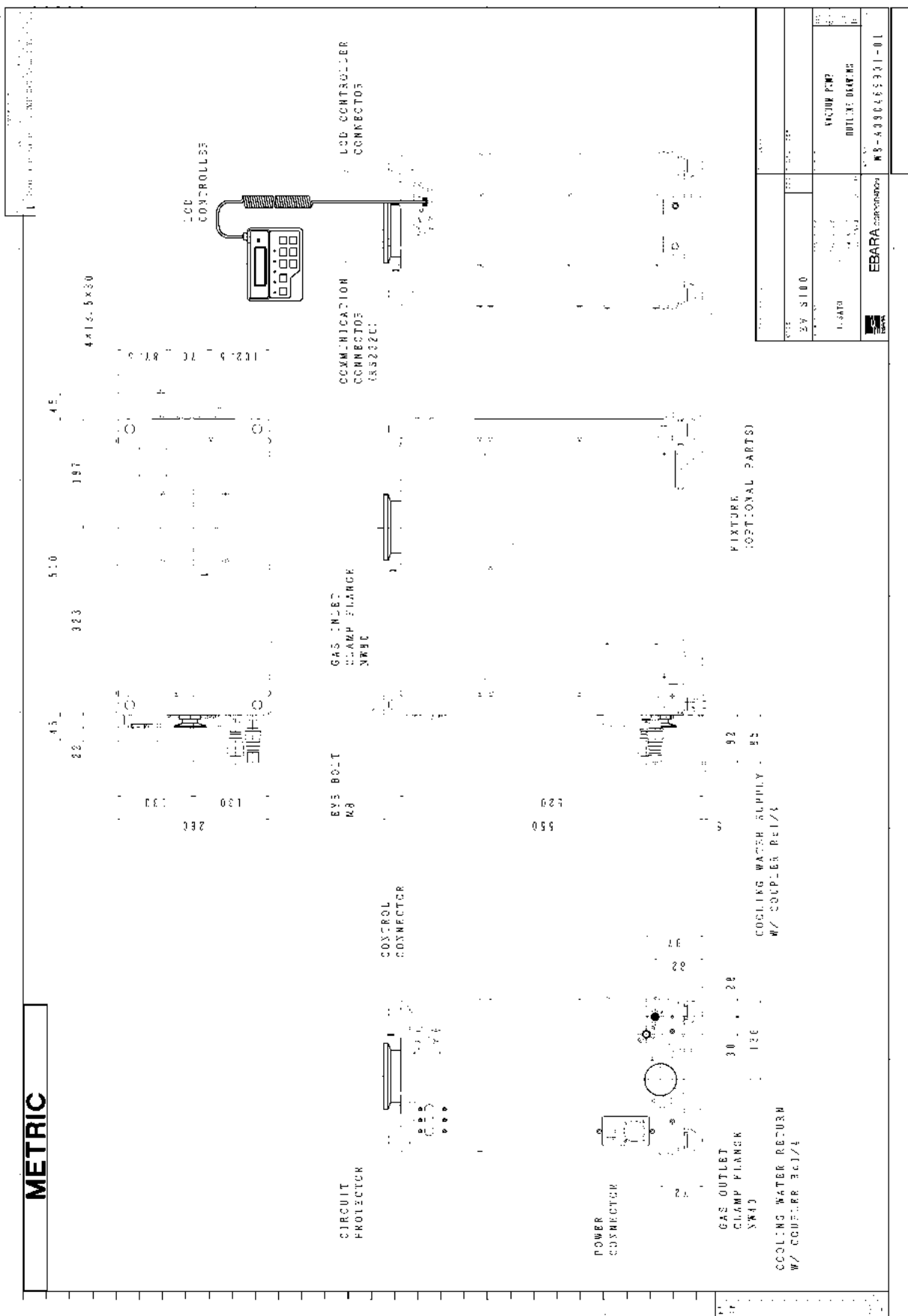

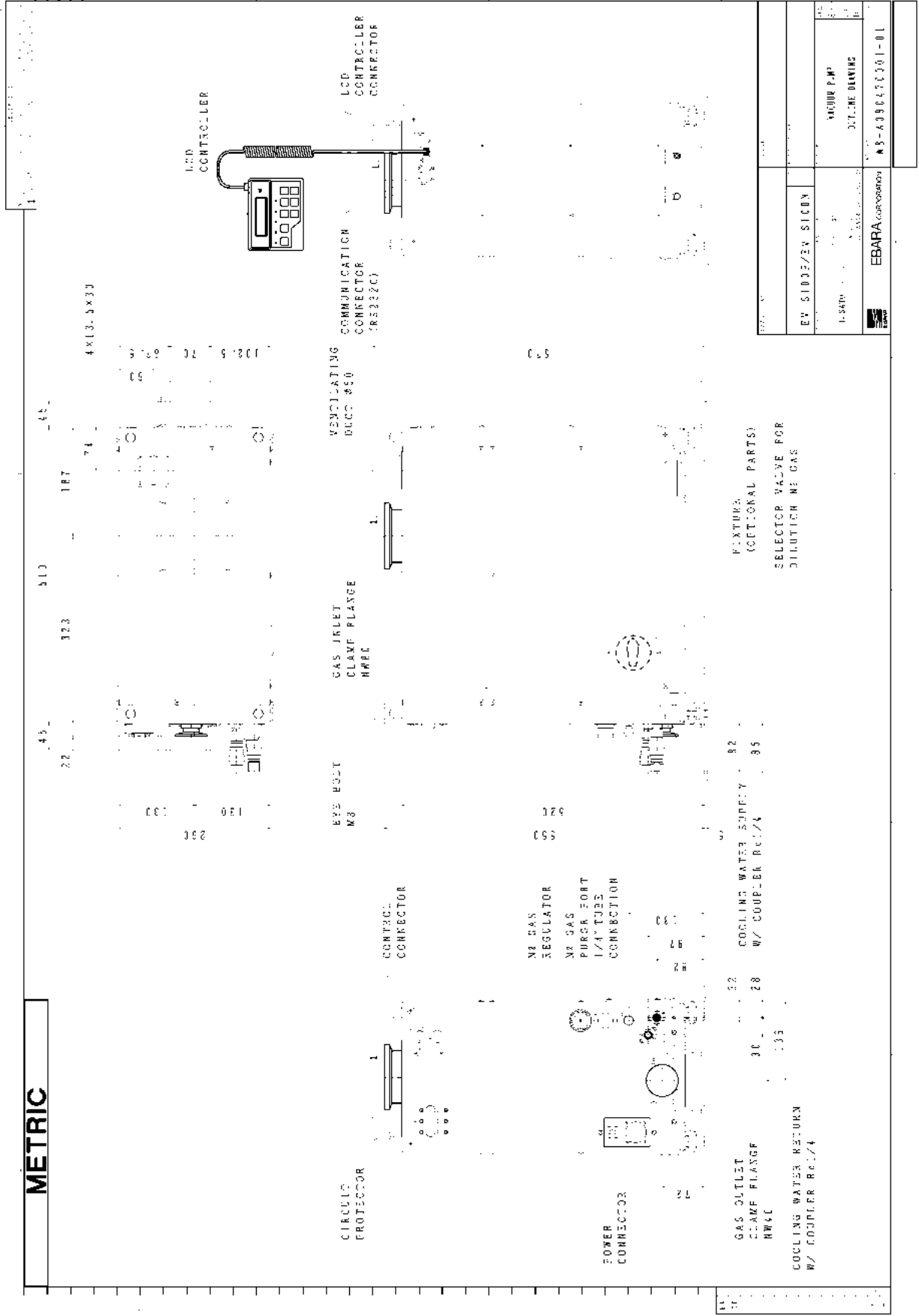

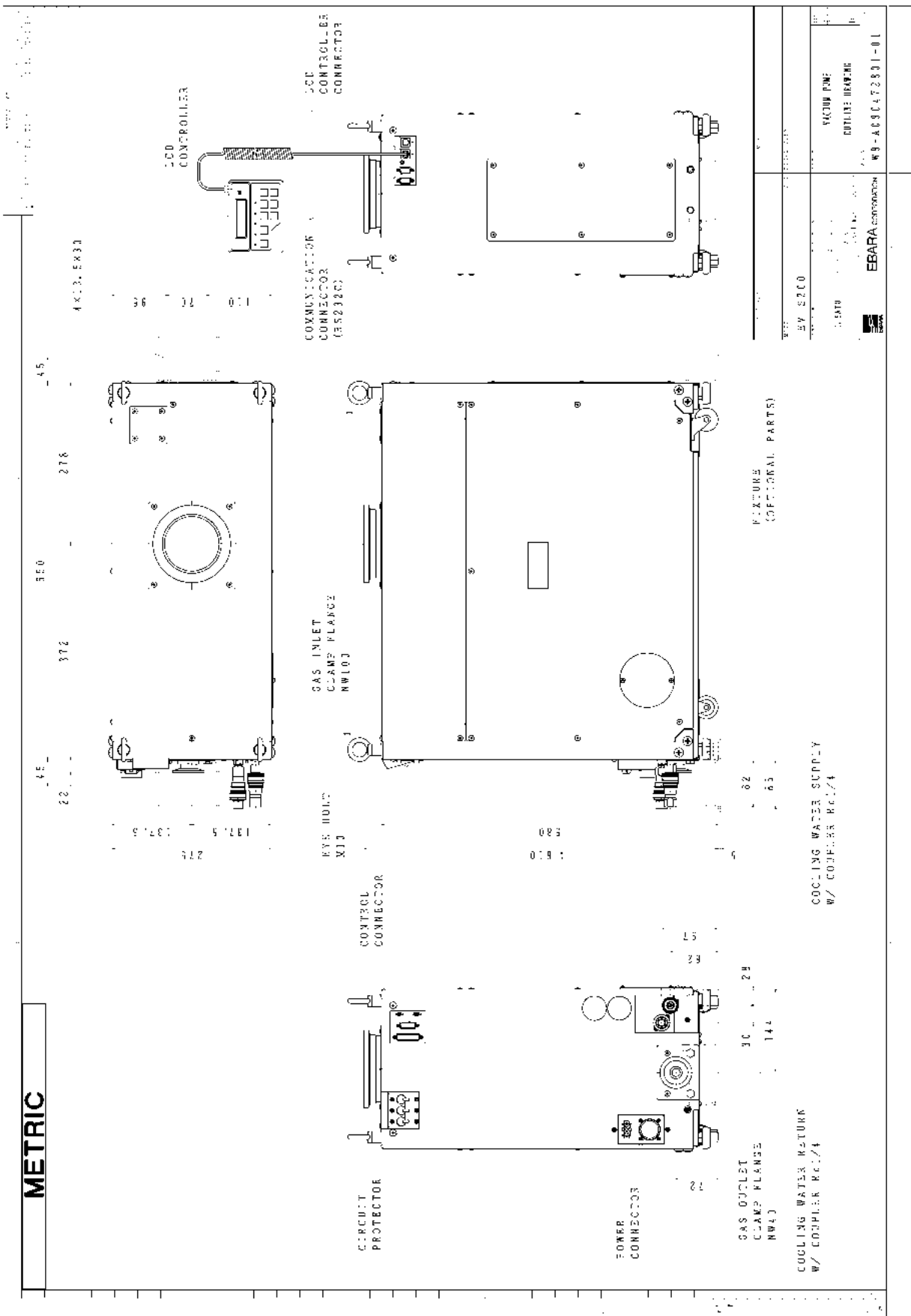

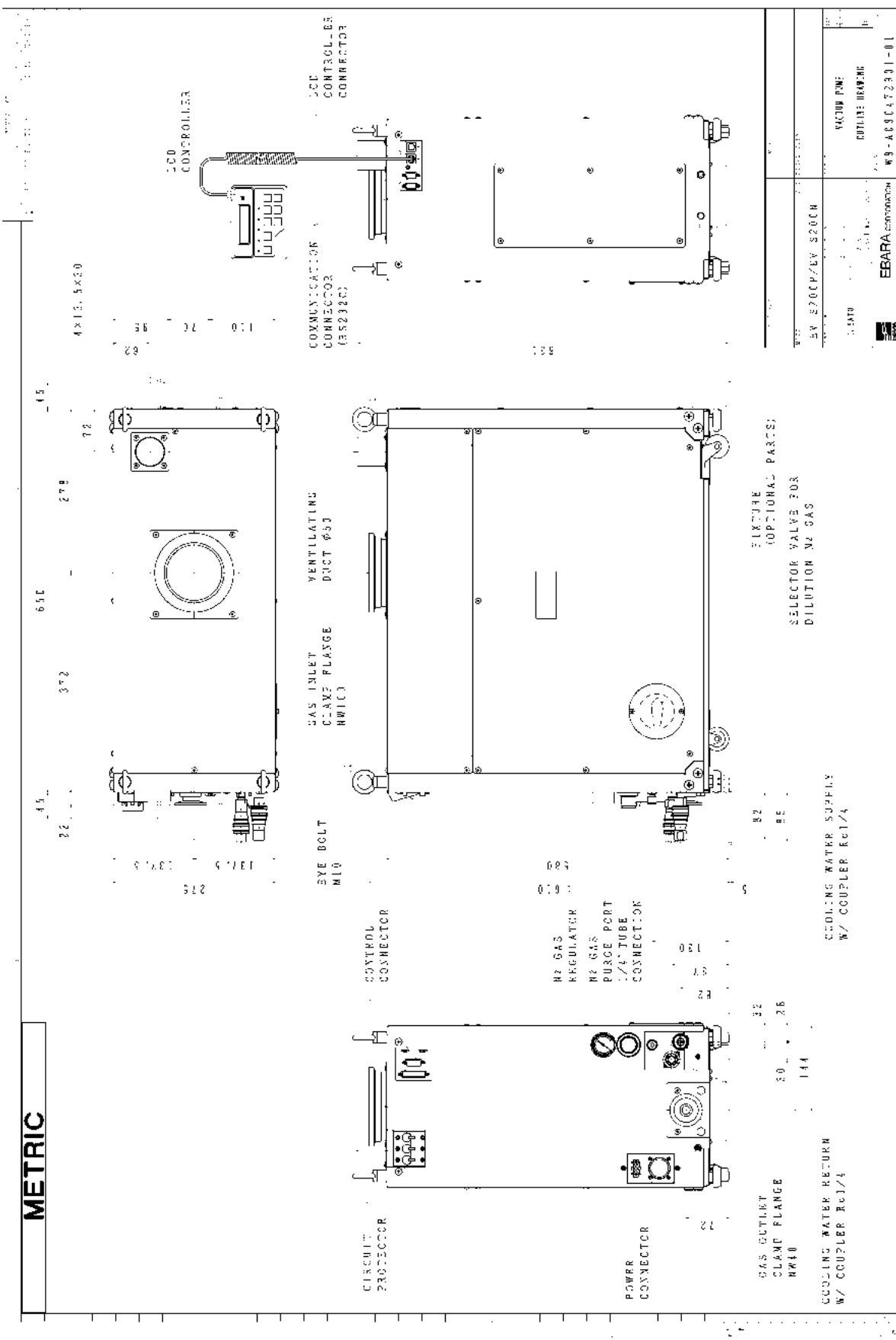

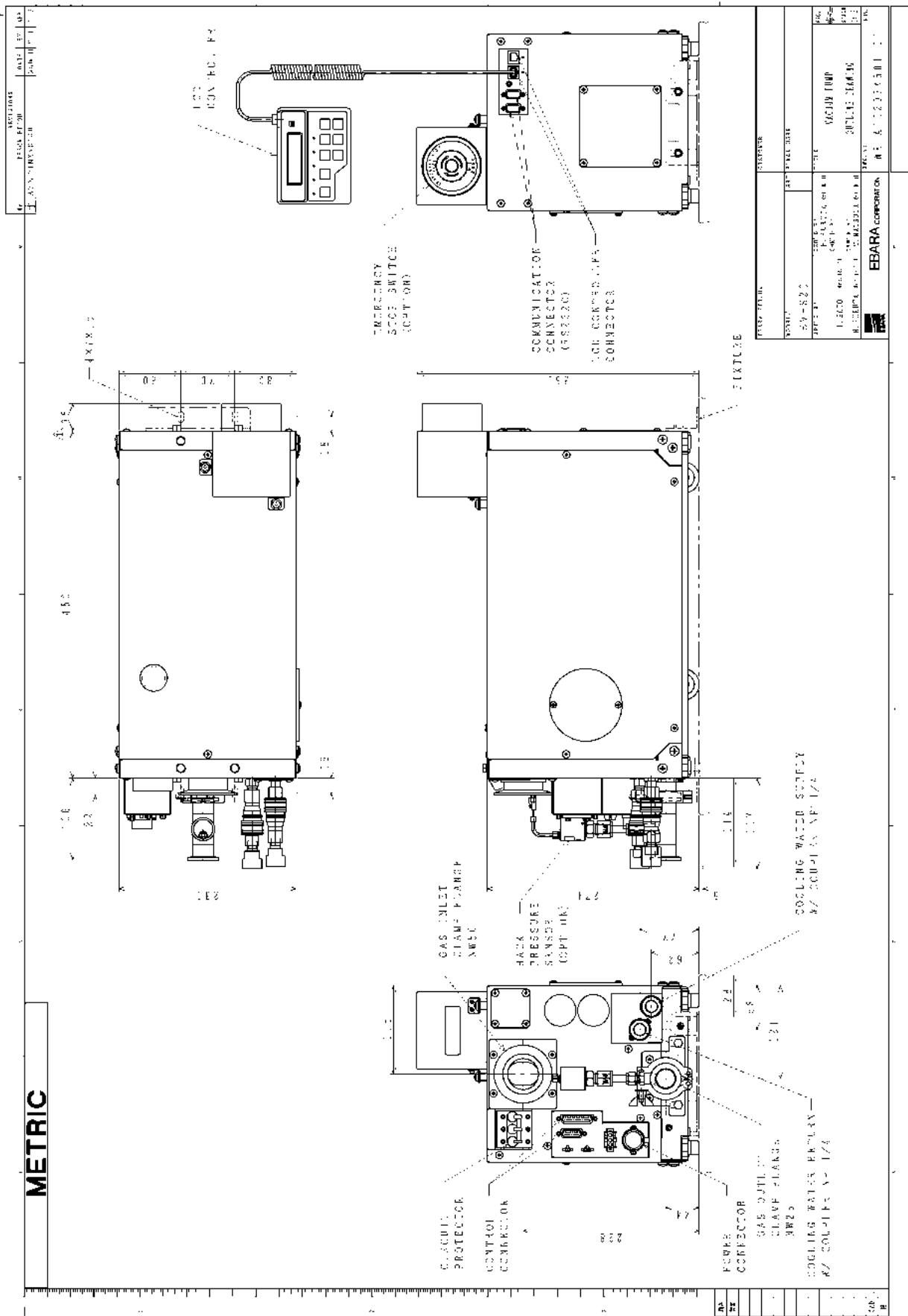

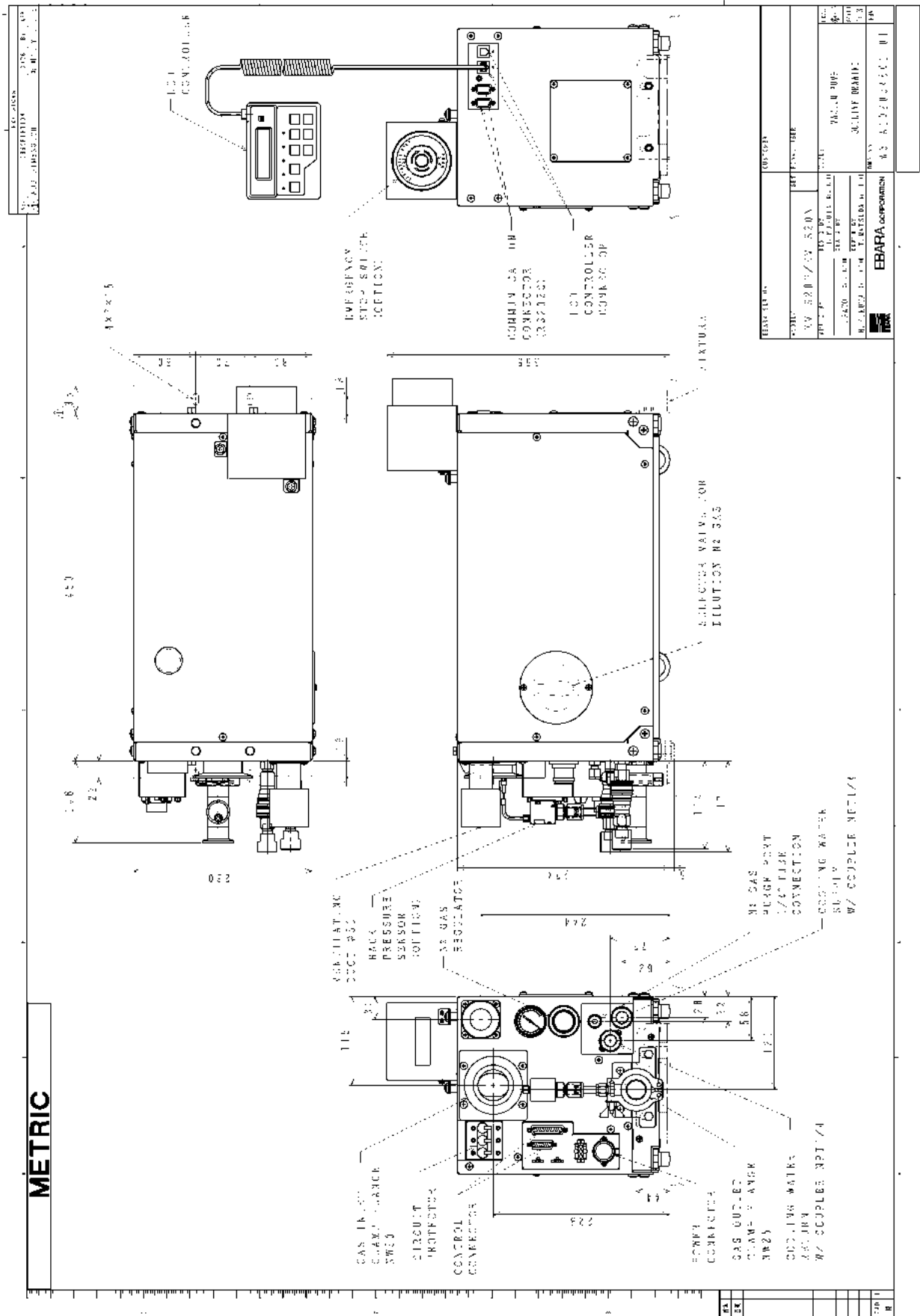

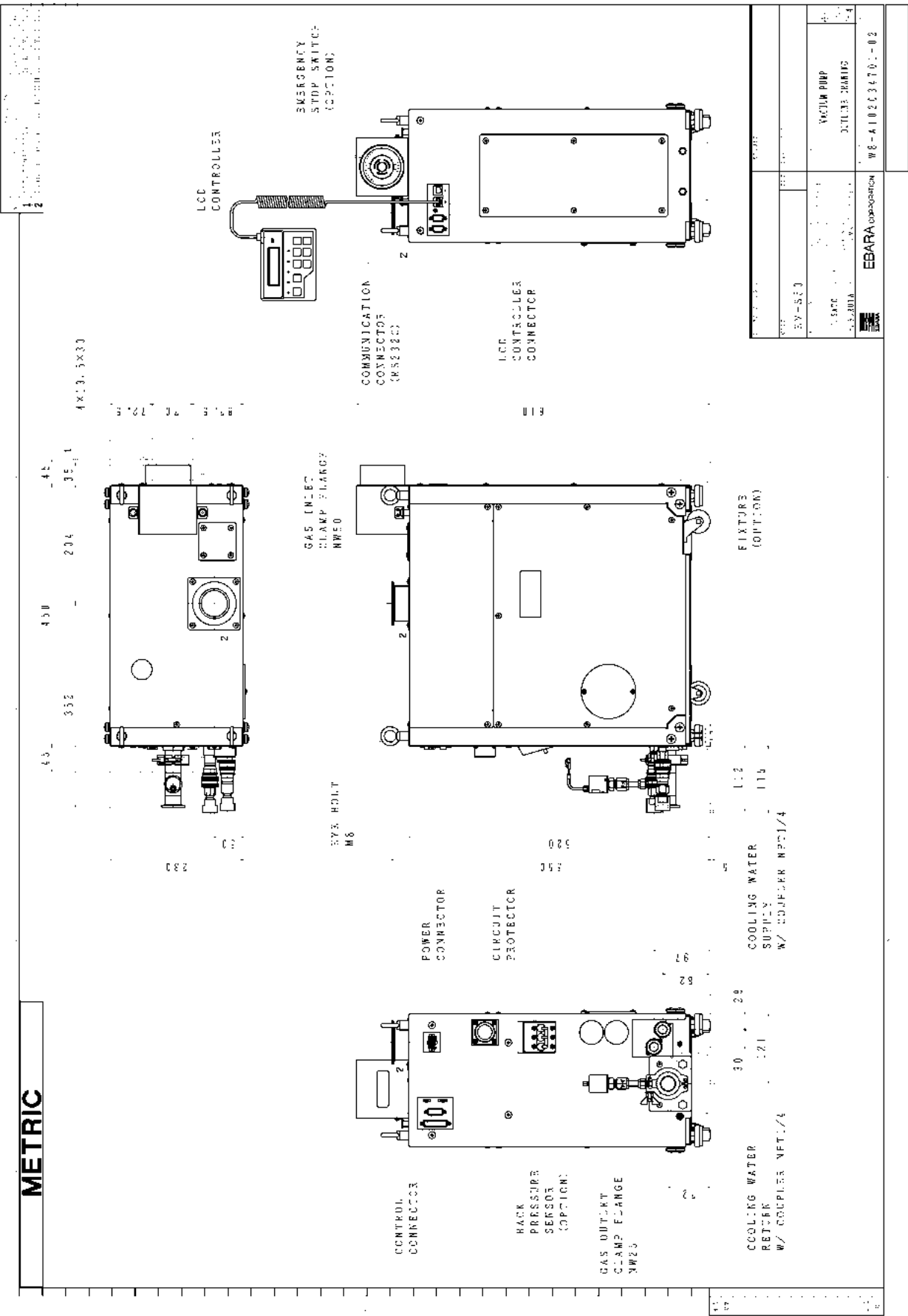

METRIC

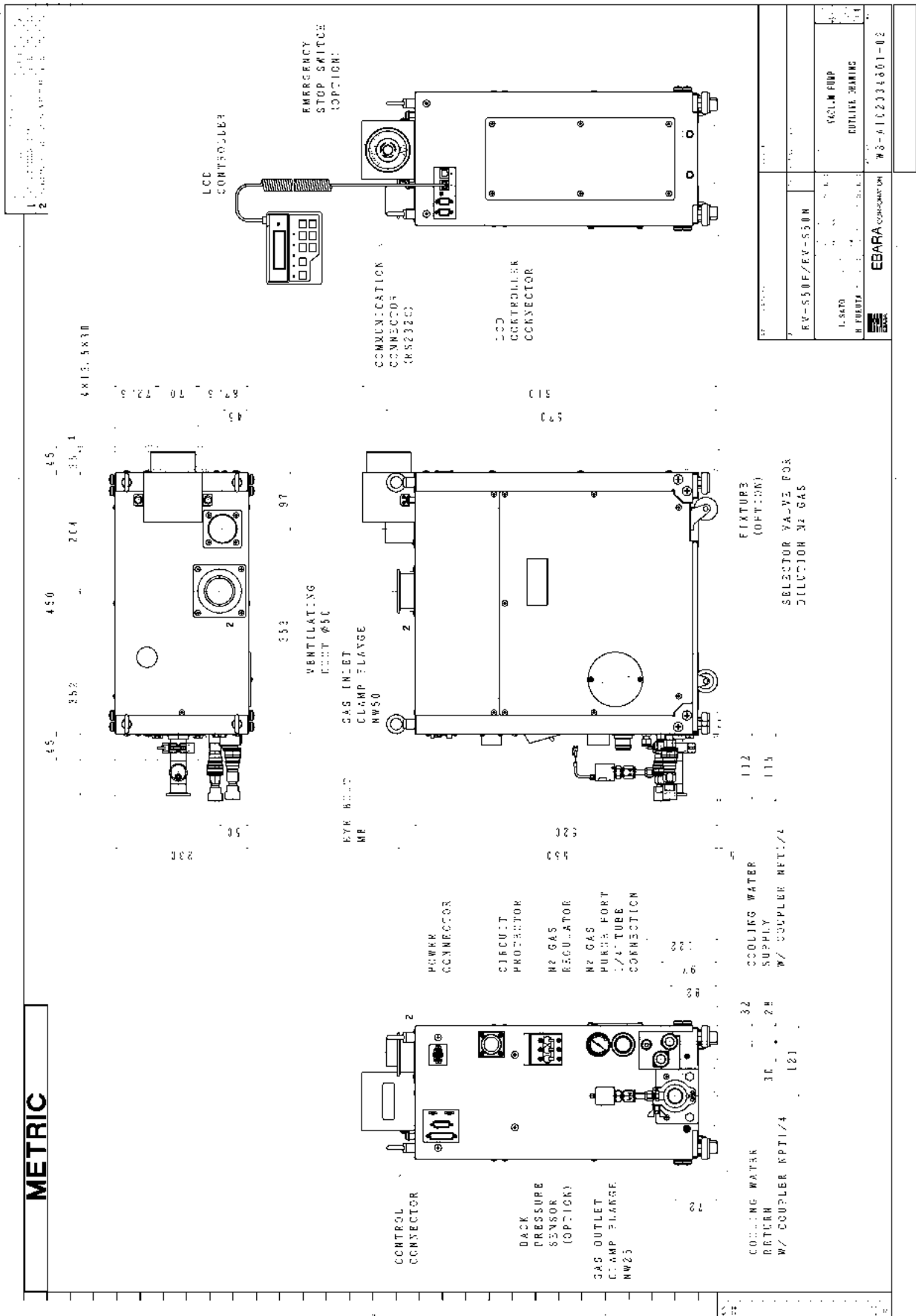

| | |
|-----------------------------------|-----------------|
| RV-550F/EV-550N | |
| L-SKTD | MAGNUM |
| H. HUB | OUTLINE DRAWING |
| EBARA CORPORATION W3-610234601-02 | |

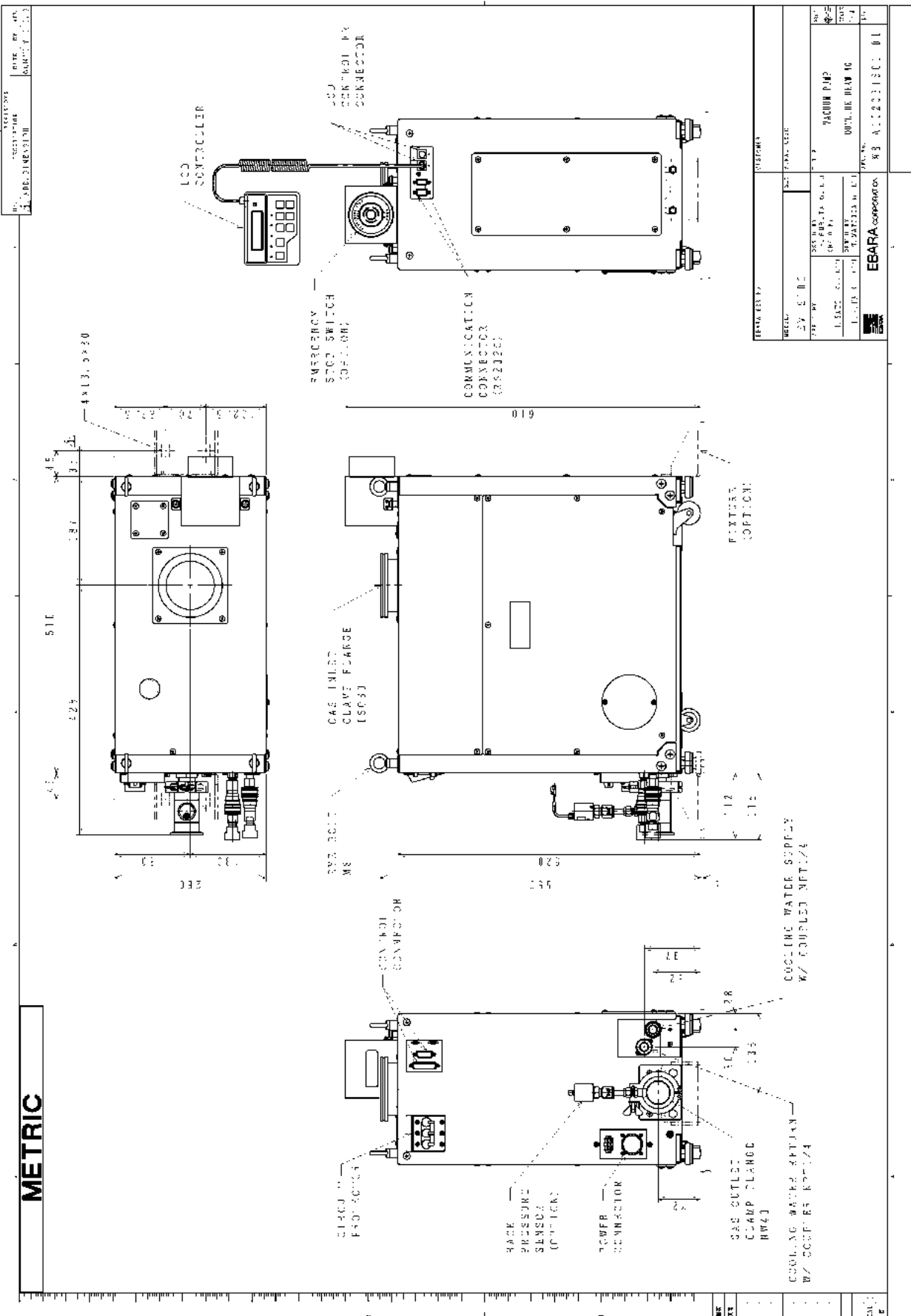

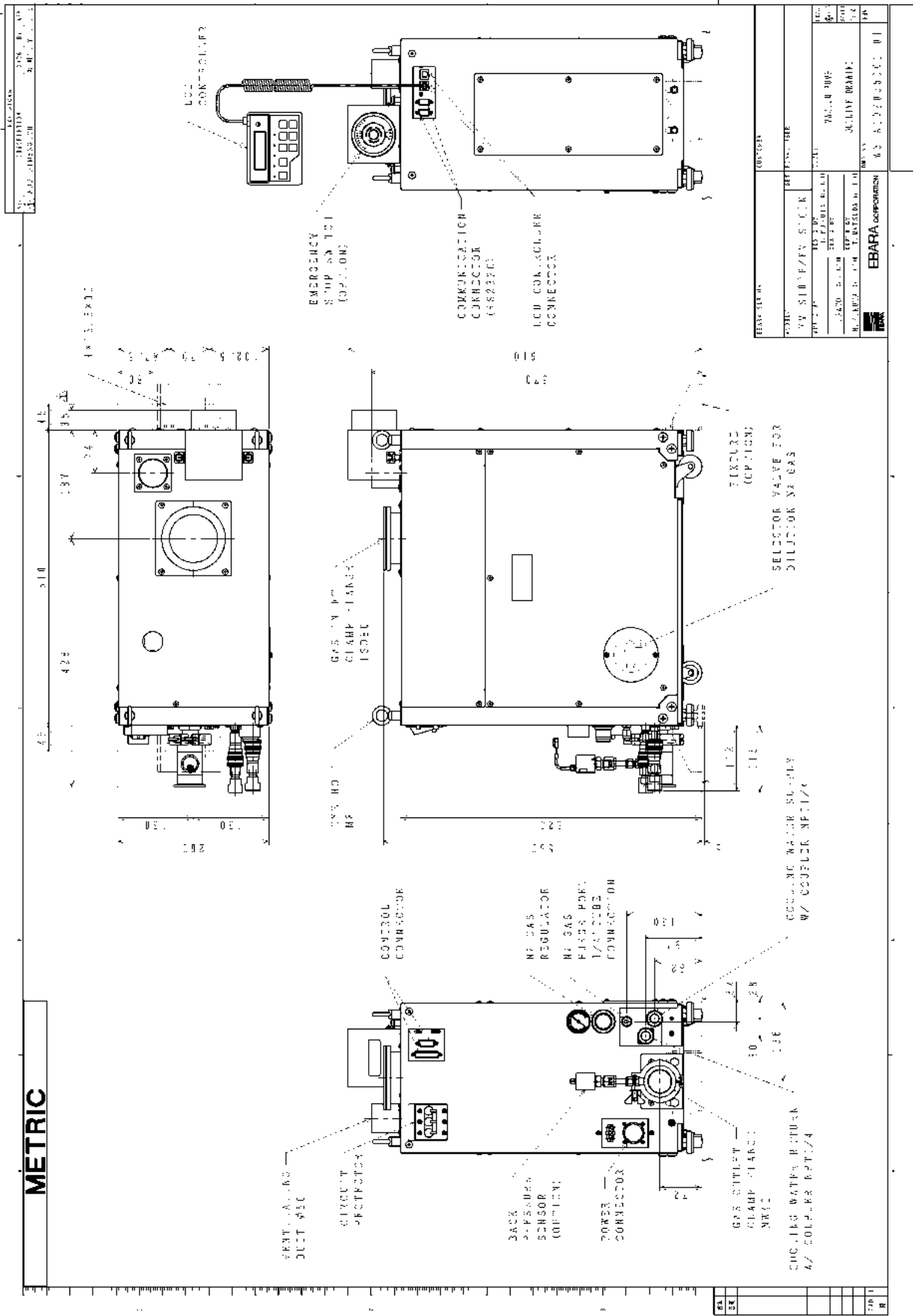

3.5.4 Performance Curve

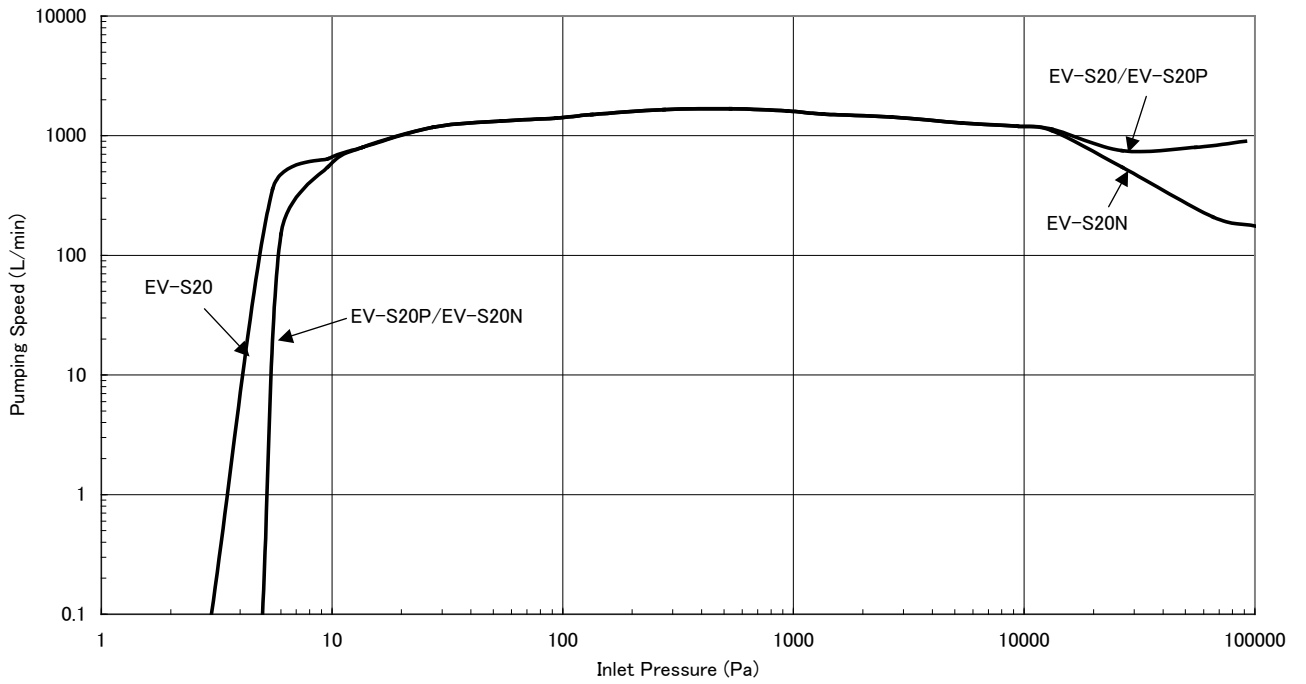

Fig 3.1 MODEL EV-S20(P/N) Performance Curve

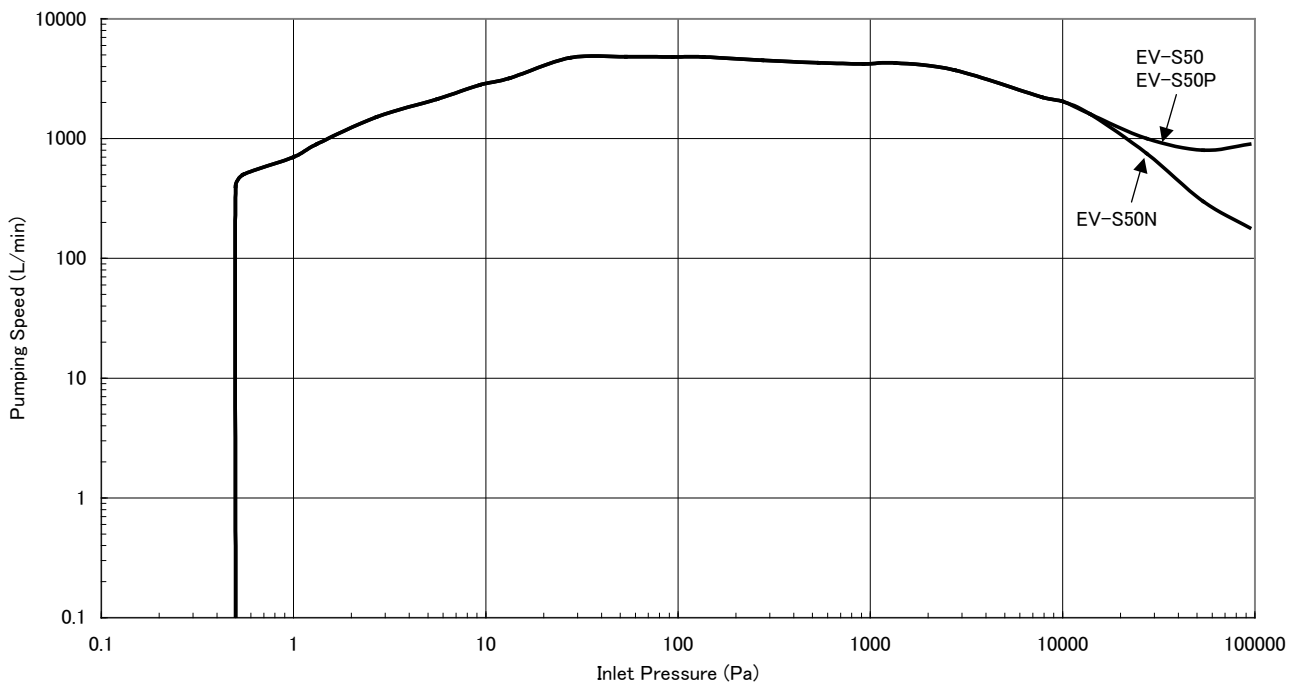

Fig 3.2 MODEL EV-S50(P/N) Performance Curve

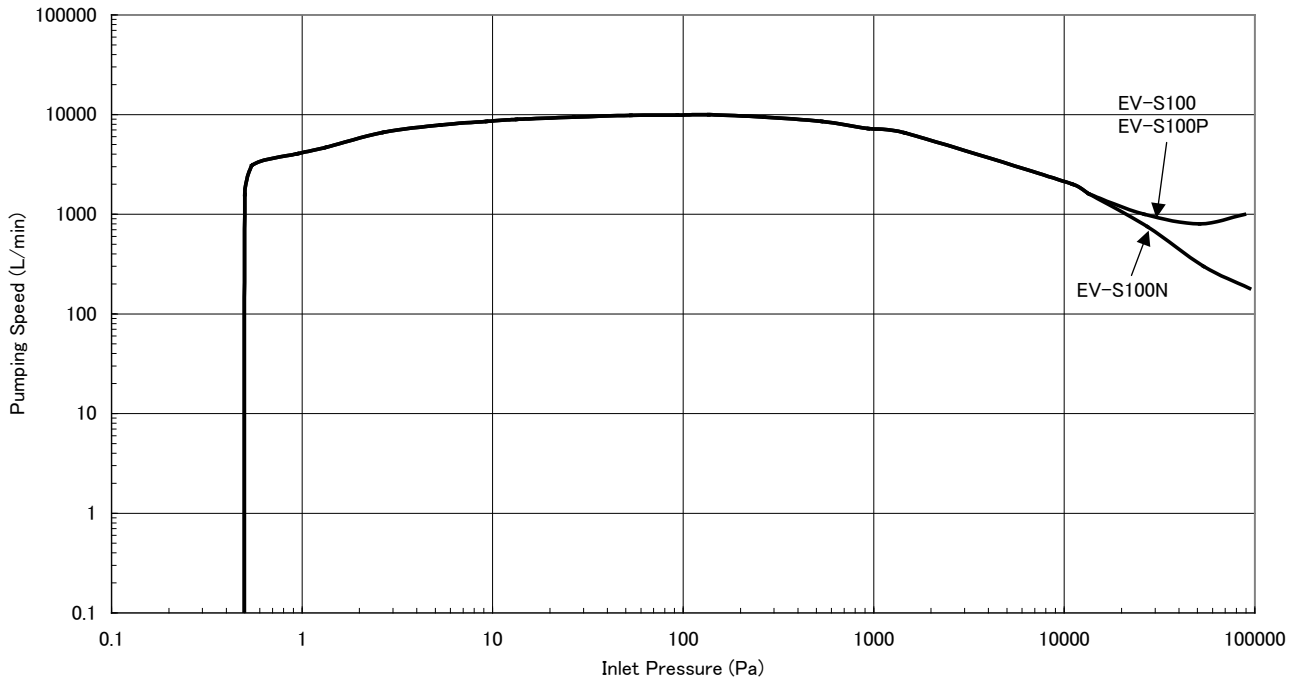

Fig 3.3 MODEL EV-S100(P/N) Performance Curve

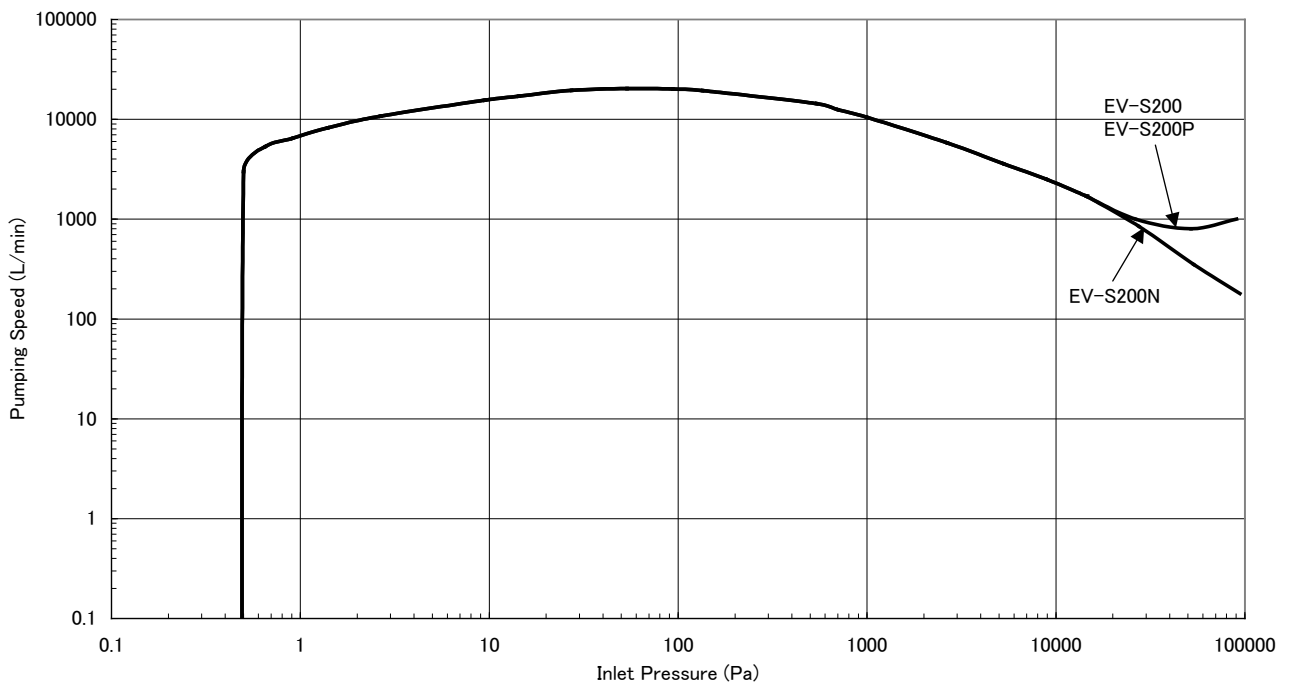
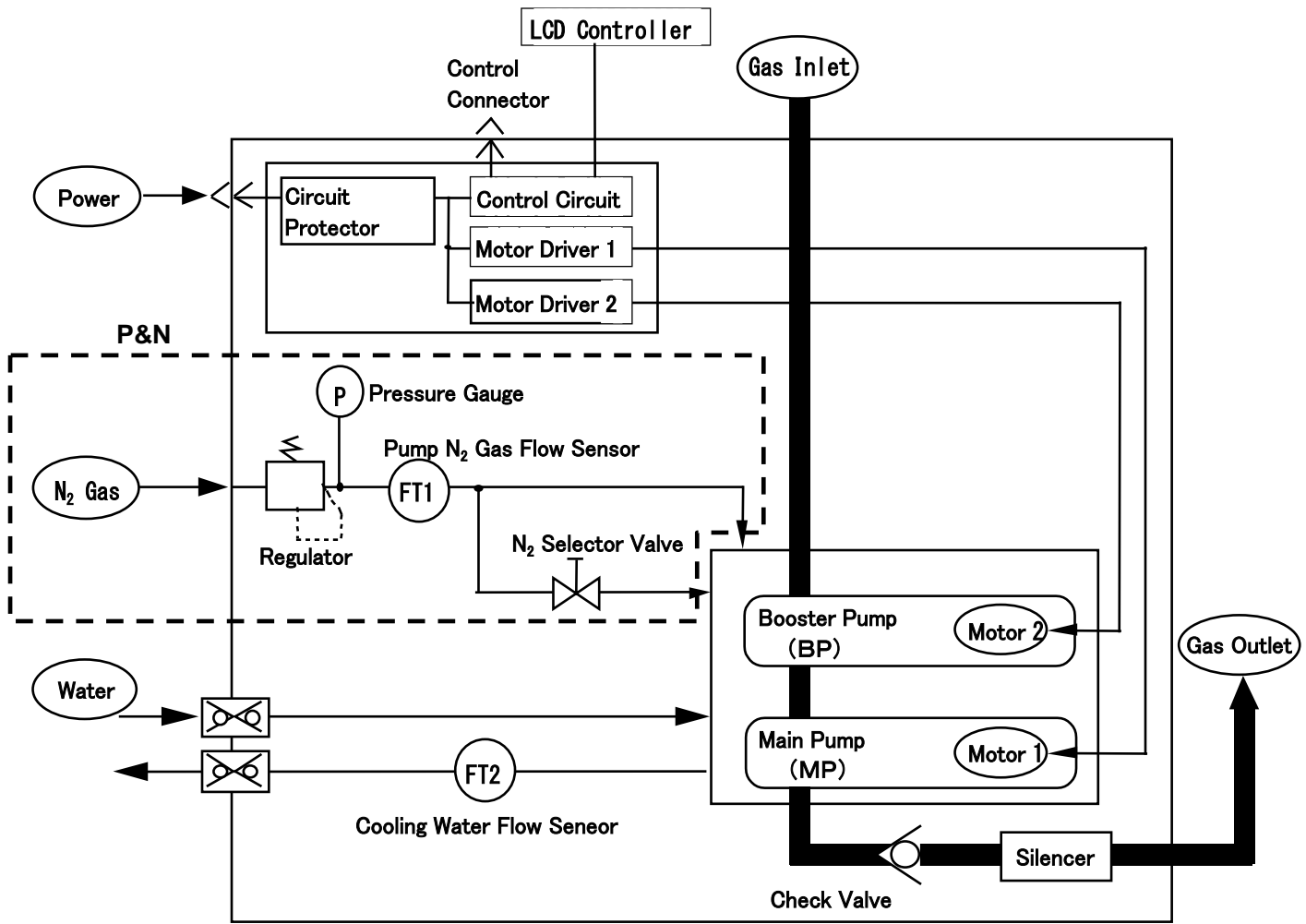

Fig 3.4 MODEL EV-S200(P/N) Performance Curve



* The MODEL EV-S20 pump is supplied without a booster pump (BP).

Figure 3.5 System Flow

4. Installation

Be sure to take the following cautions and instructions into account when installing the pump.

4.1 Movement and Fixation

4.1.1 Location

These pumps are designed for indoor installation. To install the pump, select a place with little exposure to dust and humidity and not subject to dew condensation. Also allow for sufficient space to ensure easy pump installation and disassembly for maintenance.

 **CAUTION** Install pump in a location at an ambient not exceeding 30°C. Particular caution is required when the pump is operated in an enclosed room.

 **CAUTION** A gap of at least 50mm should be left open for ventilation between the pump cover and the adjacent equipment.

4.1.2 Caster and adjustment foot

Casters and adjusters of four each are attached under the pump base. When moving the pump, lift up all of the four adjusters. To lift them up, use the wrench and turn them to the left.

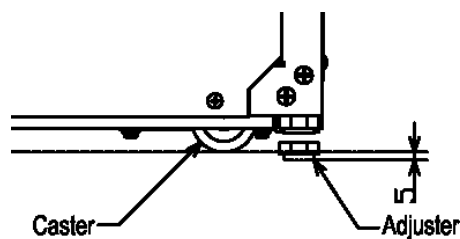





Fig. 4.1 Caster

 **WARNING** Be careful not to overturn the pump when pushing and pulling it sideways, because the width of the pump is small to its height.

 **CAUTION** The neck portion of the casters will vibrate during caster movement. Be sure to keep your fingers and feet out.

 **CAUTION** Do not step on the pump or place objects on it.

To fix the pump, turn the adjusters to the right to lower them.

Adjust the height of the feet evenly to ensure that the pump base is level.

The difference in height between the two sides of the pump base shall not exceed 1mm.

The adjustment allowance is approximately 5 mm.

[**NOTE**] If the pump is not leveled, shortage of the lubrication oil supply to the bearing may be caused.

[**NOTE**] To prevent vibrations and airborne noises, keep horizontal level of pump with the adjustment feet.

4.1.3 How to stack pumps

(1) Adjust both pumps by adjuster-foot, then stack and fix them at both front and back side by the fixing bracket. Please refer to Fig.4.2

(2) Please make sure to tighten the fixing bolt enough to fix the bracket.

(3) Please fix a lower pump and the floor.

 **CAUTION** Please do not move the pumps with stacked.

 **CAUTION** Please do not stack three pumps or more.

 **CAUTION** Please fix to a floor firmly.

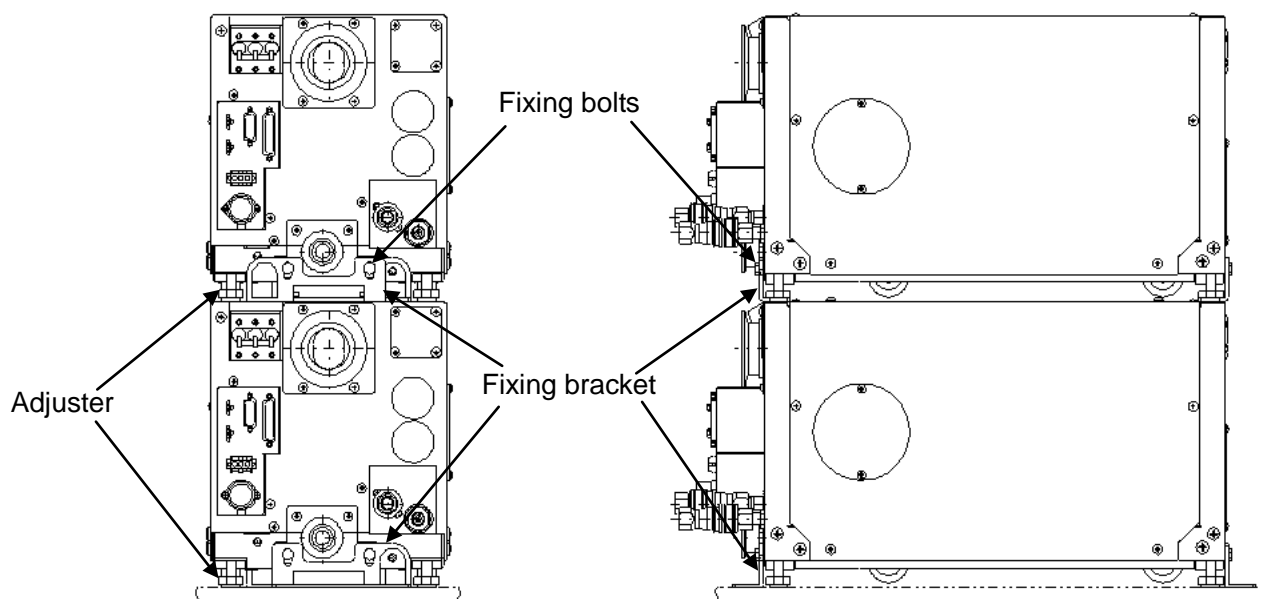

Fig. 4.2 How to stack pumps

⚠ WARNING In MODEL EV-S20 type pump, the bolt which is fixing the fixing bracket to a pump is M6×16. This fixing bracket can use as lifting bracket.

When you use this bracket as lifting bracket, you use M6×12 bolts for fixing this bracket to the upper side of the pump. In this case, you cannot use the M6×16 bolts, because the M6×16 bolts reach to an internal part and have a possibility to break it.

- Using this bracket as a fixing bracket, please use the bolt of M6×16(hexagon head bolts).
- Using this bracket as a lifting bracket, please use the bolt of M6×12(hexagon head bolts).

4.1.4 Pump Fixation (Option)

The pumps are provided with casters for easy transportation and foot adjustments for anchoring and height adjusting, as described in Section 4.1.2. The pump, however, may unexpectedly move or fall down when an earthquake occurs. To prevent such events, EV-S dry pumps (CE/SEMI compliant) are equipped with brackets to secure the pump body to the floor. Fix the pump to the floor or other firm ground with the brackets at the installation.

For dimensions of the bracket, see the accompanying drawing.

Anchor bolts should be fit for conditions of the floor where the pump is anchored.



WARNING

In MODEL EV-S20 type pump, the bolt which is fixing the fixing bracket to a pump is M6×16. This fixing bracket can use as lifting-bracket.

When you use this bracket as lifting bracket, you use M6×12 bolts for fixing this bracket to the upper side of the pump. In this case, you cannot use the M6×16 bolts, because the M6×16 bolts reach to an internal part and have a possibility to break it.

- Using this bracket as a fixing bracket, please use the bolt of M6×16(hexagon head bolts).
- Using this bracket as a lifting bracket, please use the bolt of M6×12(hexagon head bolts).

METRIC

1 TOTAL WEIGHT 63 KG
LOADED WEIGHT/ EACH FOOT 15 KG



DETAIL A
(S-111)

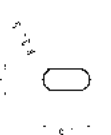

DETAIL B
(S-112)

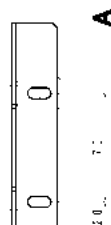

A

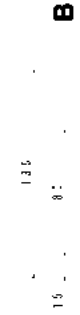

B



FIXTUREX2
(MATERIAL: CARBON STEEL)

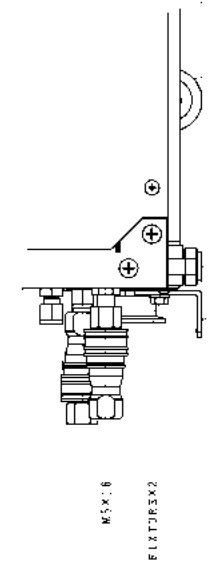

CENTER OF ANCHOR

DETAIL OF FIXING

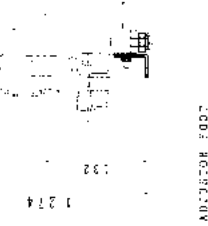

ANCHOR FOOT

CE/SEMI/NRTL:200V

- NOTES
- 1) MARK INDICATES CENTER OF GRAVITY OF PUMP UNIT.
 - 2) M6 SIZED BOLTS SHALL BE USED AS ANCHOR.

| | |
|-------------------|-------------------|
| EV-S20P/E1-S20P | WASH PUMP |
| EV-S20 | LOCATION ELECTRIC |
| EBARA CORPORATION | |
| WB A85048700 01 | |

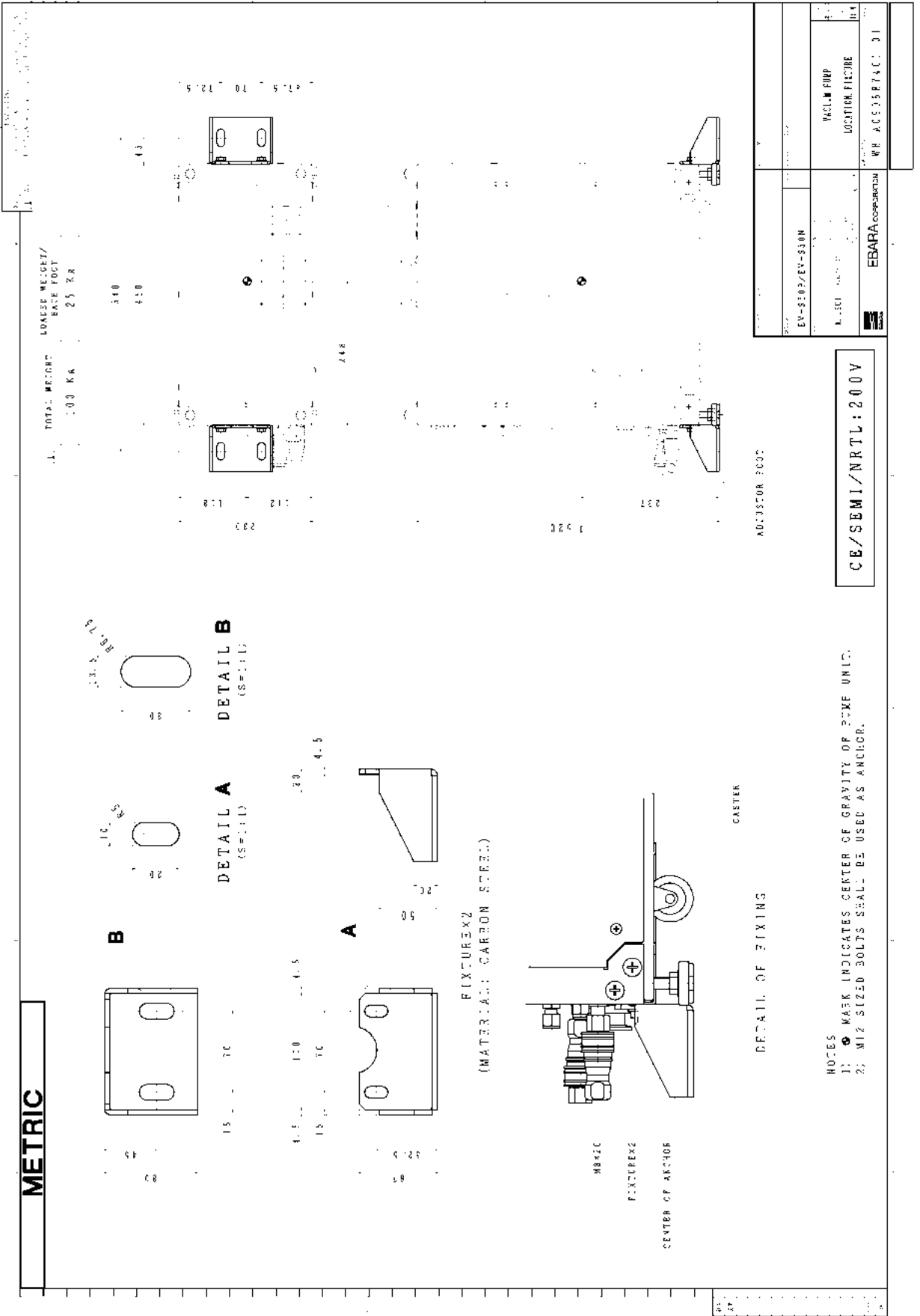

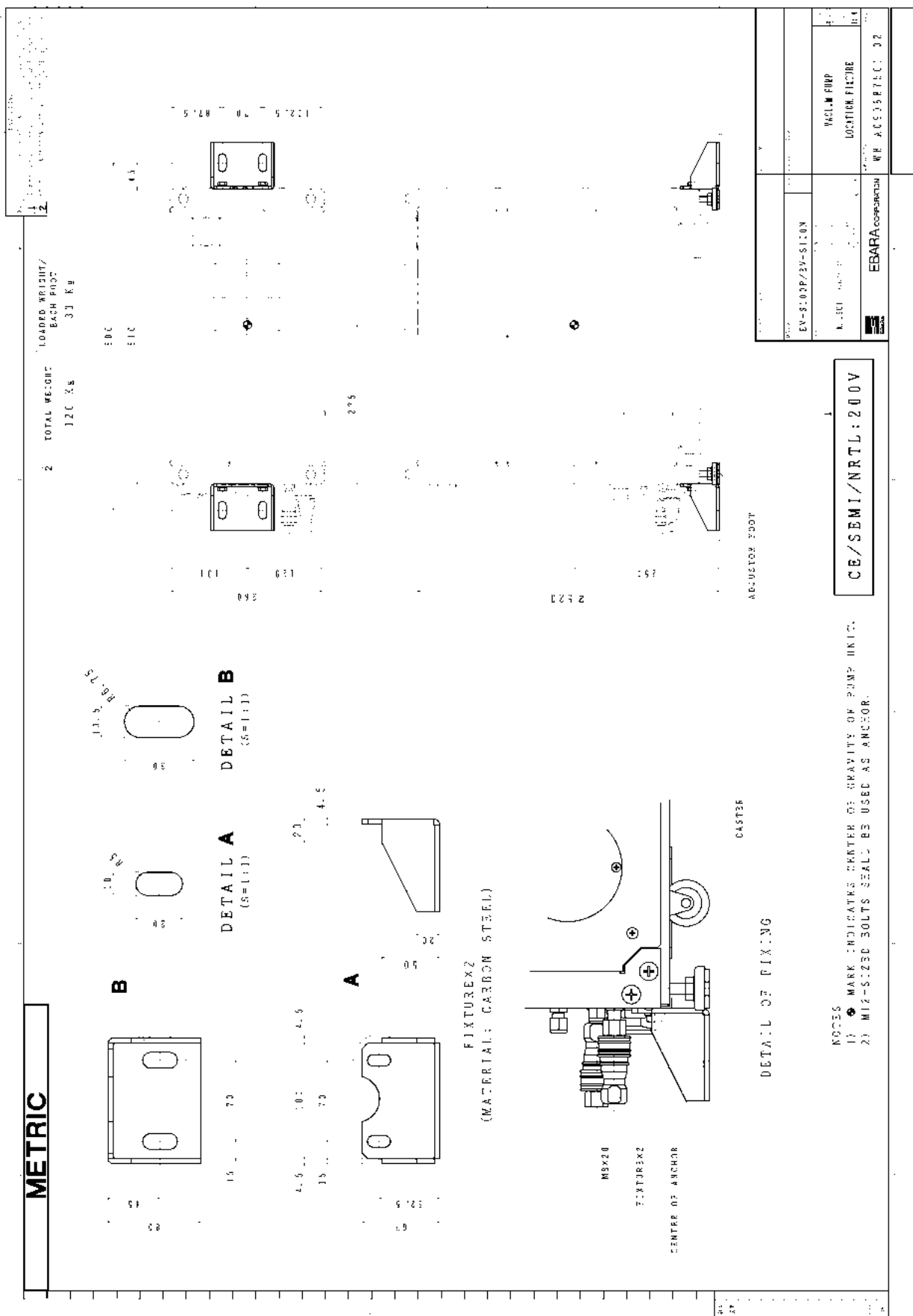

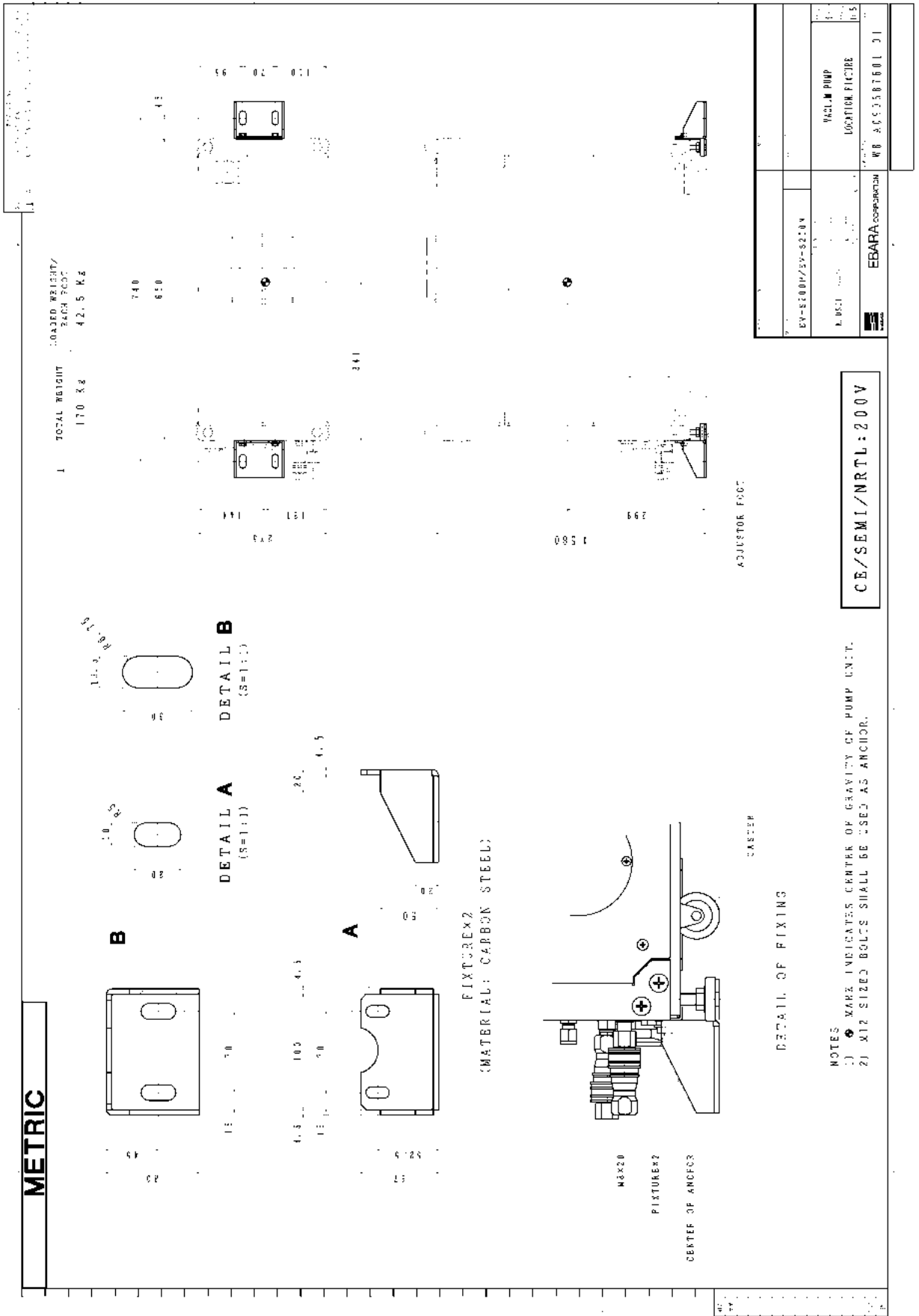

4.2 Piping

4.2.1 Vacuum and Exhaust Piping

Connect the vacuum and exhaust pipes to the suction and exhaust flanges.

A narrow clearance is maintained in the pump for rotor rotation. The ingress of foreign objects into the pump interior will therefore prevent the pump from operating. Be sure therefore to heed the following cautions when making the pipe connections.

- a) Remove all foreign matter from inside the piping.
- b) When connecting be sure that no dirt or dust particles adhere to the flange surfaces and/or that the flange surfaces are damaged.
Provide a suitable means of preventing the ingress of reaction by-products adhering to the APC valve and wafer fragments. For this purpose, a filter may be installed.
- c) The weight of the pipes attached to the pump can cause misalignment and leaks from the flange connections. Be sure therefore to support the piping properly and not to apply undue force when aligning the flange faces.
It is recommended to insert flexible bellows when connecting the pipes to the suction and exhaust flanges of the pump.
The length of the flexible bellows on the vacuum (suction) side will vary according to the vacuum drawn. Be sure to connect so that no undue force can be applied to the flexible bellows.
- d) Please decide a part to connect to the pump exhaust so that the exhaust pressure is not beyond atmospheric pressure.



WARNING Be sure to check for leaks after you have installed the pump. Leaks will cause serious danger due to the discharge of harmful and hazardous substances and the occurrence of unpredictable reactions associated with the admission of air into the pump. When checking for gas leaks by pressurization, please pressurize by less than 0.05 MPa into the purge port and do check.



WARNING The pump casing, inlet piping and exhaust piping become extremely hot during operation and for some time after stopping. Be sure that pump and exhaust piping do not come in contact with humans or inflammable substances. Do not remove the pump cover during operation.



CAUTION The exhaust piping made by polyvinyl chloride causes the noise through the pipe.

4.2.2 Cooling Water Piping

Be sure to connect the cooling water pipes to the correct inlet and outlet ports.

The connector ports are provided with couplers. Push in the plug till the end of socket. Socket sleeve returns to front.

Be sure that the supply/return plugs are not connected in reverse. The diameters are slightly different. In/Out markings are provided on each plugs.

When the coupler is pulled out the water pipe will be automatically blocked. Use cooling water corresponding to the specifications of Table 4.1 below.

Table 4.1 Industrial Water Supply Quality Specification

(Japan Industrial Water Association, Industrial Water Quality Standards Committee)

| | | |
|--------------------------------|-------|---------|
| Turbidity | (ppm) | 20 |
| pH | | 6.5-8.0 |
| Alkalinity(CaCO ₃) | (ppm) | 75 |
| Hardness(CaCO ₃) | (ppm) | 120 |
| Evaporation residue | (ppm) | 250 |
| Chlorine ion | (ppm) | 80 |
| Iron | (ppm) | 0.3 |
| Manganese | (ppm) | 0.2 |



CAUTION Even when the cooling water flow rate drops, the pump will continue to operate until the pump part reach a temperature corresponding to the safety limit.

The material selected for the water piping of facility side should have a heat resistance so that it can withstand a maximum temperature of at least 70°C at the operating pressure.



CAUTION When several pumps are used, be sure to connect the cooling water pipes to each pump in parallel. The cooling water will flow more or less easily according to the type of pump and the piping. Be sure to select the correct piping so as to ensure the appropriate cooling water flow rate for all pipes used.



CAUTION When the cooling water connections are incorrect and the flow is reversed, a flow rate different from the normal value will be displayed. Nor will the pump will not be cooled properly.

This will result in accident.

Be sure therefore to connect correctly to avoid problems.



CAUTION When the cooling water supply is left on while the pump is stationary dew condensation will form on the water-cooled parts in locations with high humidity.

Make it a rule therefore to stop the cooling water when water droplets can be detected on the outer surface of the pump cooling water piping as this suggests the possibility of dew condensation in the pump.

4.2.3 N₂ Gas Piping

Cut tube at right angles and make the end-face perfectly smooth. Then connect the tube to the tube fitting assembly of the N₂ gas purge port. The tube is a push-fit onto the shoulder of the tube fitting assembly.

Secure the tube fitting assembly properly and tighten the retaining nut by hand. After this, use a tool to tighten the nut further by 1 + 1/4 turns.

To connect the tube again after this, install the tube already fitted to the ferrule and re-tighten the retaining nut slightly after the initial tightening (generally, tighten by a further quarter turn after tightening by hand).

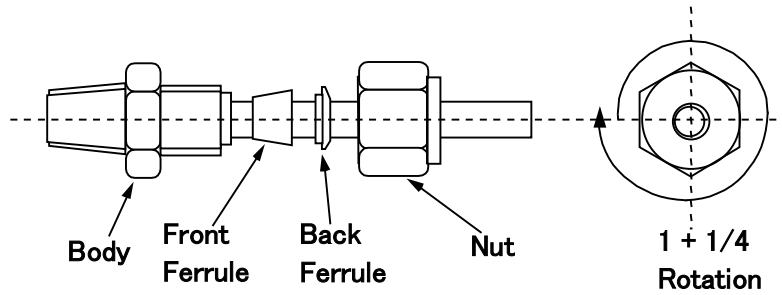

Fig. 4.2 Tube Fitting Assembly

CAUTION For safety, be sure to use N₂ gas which purity is more than 99.999%. Impurities of N₂ gas may cause an accident when the pump is used for exhausting toxic and/or inflammable gases.

4.2.4 Ventilation Duct (MODEL EV-S***N / MODEL EV-S***P)

To exhaust hot air, suck off the air inside the cover from the ventilating duct port. Without proper ventilation, the temperature inside the cover will continue to rise until an ALARM is generated. This will result in serious problems.

The pump does not provide gas leak detector. So it is recommended that gas leak detector should be installed in duct piping to take exhaust flow interlock.

A substance which does not corrode with used gas shall be used as the material of the exhaust duct.

In case of detecting gas leakage, stop the gas flow into the equipment

CAUTION For safety, be sure to ventilate through the ventilation duct when the pump is used to exhaust toxic and/or inflammable gases. Do not combine the ventilation duct with the pump exhaust piping .

CAUTION Even when the pump is used for exhausting process gases that are not toxic and/or inflammable, do not combine the ventilation duct with the pump exhaust piping. The exhaust noise of the pump will give rise to acoustic resonance inside the pump unit and result in an abnormal noise being generated.

CAUTION Never operate the pump without pump cover for safety.

4.3 Electrical Wiring



WARNING Be sure to keep the power supply to the pump turned off and lock-outed until you have finished the wiring and connecting work. Also interrupt the Circuit Protector (CP) during this.



WARNING Electrical wiring shall be carried out only by qualified electricians.



CAUTION Do not apply the power supply from the pump's power pack to any other equipment as this will result in malfunctioning of the control units and in pump failure.



CAUTION CB is not installed in the pump unit. Please install CB based on the law and the standard in the installation region. (Please attach the Circuit breaker(CB) type of UL489 to SEMI correspondence.)



CAUTION Do not supply a power supply to other instruments out of a pump package. It becomes an operation mistake of a control part, and a cause of pump failure.

4.3.1 Power Supply Wiring

Fig4.3.1,2,3 show the power supply connector and a control signal connector position on the control panel.

- MODEL EV-S20

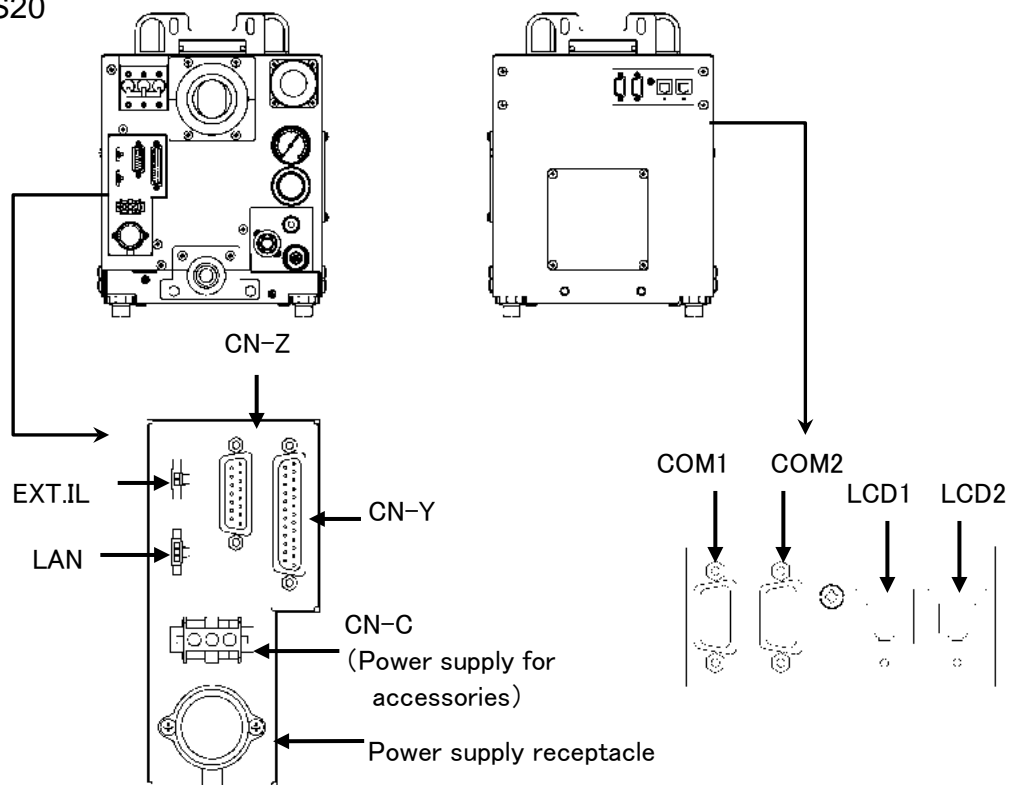

Fig 4.3.1 Power Supply and Control Signal connects position

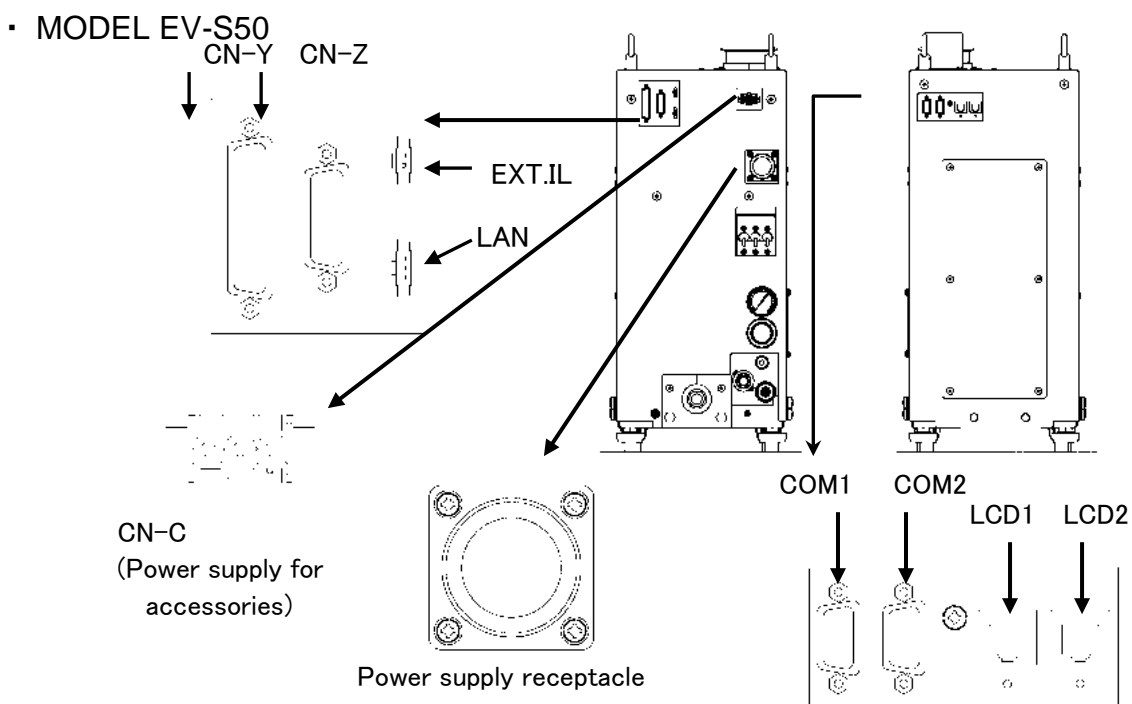

Fig 4.3.2 Power Supply and Control Signal connects position

• MODEL EV-S100/200

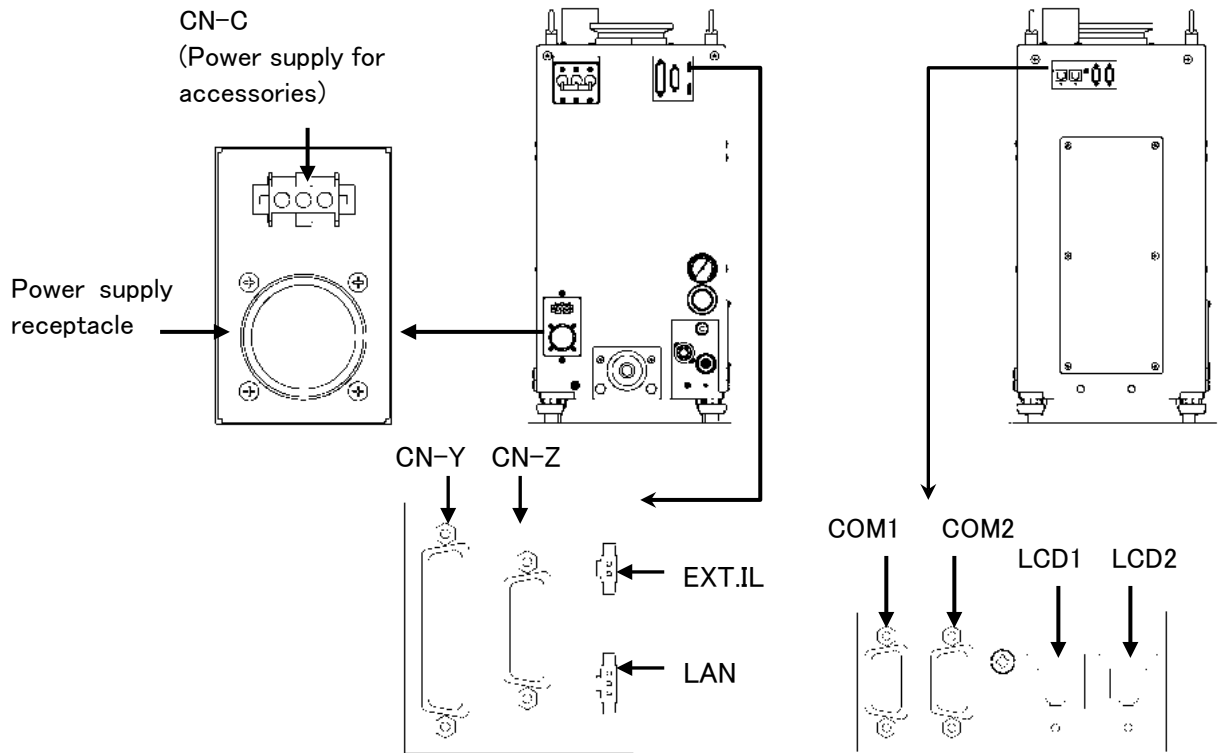

Fig 4.3.3 Power Supply and Control Signal connects position

WARNING Be sure to connect the grounding wire.

CAUTION Use the correct wiring materials and size to match the operating conditions in accordance with the power consumption rating and ambient air temperature of the pump.

CAUTION Wiring should be hard-wired or using twist-lock Hubbel type connector at power source side.

Wire the connector for the main power supply (3-phase, 200V-220V and 50Hz/60Hz). Fig. 4.4, 4.5 and Tables 4.2, 4.3, 4.4 and 4.5 show the connector pin assignment.

Please wire the connector pin by the specialized tool.

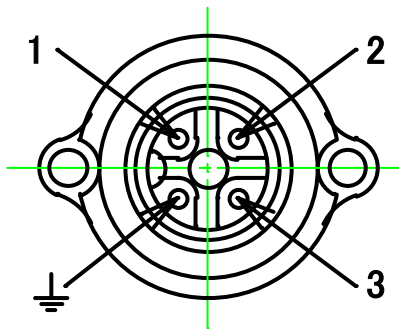

| No. | Phase |
|-----|-------|
| 1 | R |
| 2 | S |
| 3 | T |
| GND | GND |

Table 4.2 Pin Assignment of Power Supply Receptacle

Fig 4.4 Power Supply Receptacle
(As seen from connecting side)

Table 4.3 Receptacle Specification

| | |
|---------------------|--------------------|
| Pump model | MODEL EV-S20 |
| Receptacle type | C016 20C003 100 12 |
| Recep. Manufacturer | Amphenol |
| Adapted plug type | C016 20D003 100 12 |
| Suitable wire | AWG #14 |
| Power capacity kVA | 3.2 |

* Plug contact is a screw fix type. Please make sure to tighten the screw enough to fix the Plug contact.

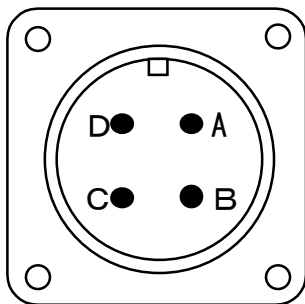

Table 4.4 Pin Assignment of Power Supply Receptacle

| NO. | Phase |
|-----|-------|
| A | R |
| B | S |
| C | T |
| D | GND |

Fig 4.5 Power Supply Receptacle
(As seen from connecting side)

Table 4.5 Receptacle Specification

| | | | |
|---------------------|---|-----------------|-----------------|
| Pump model | MODEL EV-S50 | MODEL EV – S100 | MODEL EV – S200 |
| Receptacle type | JL04HV-2E22-22PE-B-R | | |
| Recep. Manufacturer | Japan Aviation Electronics Industry Co., Ltd. | | |
| Adapted plug type | JL04V-6A22-22SE-EB-R | | |
| Suitable wire | AWG #12 | AWG #10 | |
| Power capacity kVA | 4.8 | 6.4 | 6.8 |

4.3.2 Control Signal Wiring

Connect wires to the control connector for remote operation and remote monitoring.

Tables 4.6, 4.7, 4.8 and 4.9 and Figs. 4.6 and 4.7 show the pin assignment.

Table 4.6 Receptacle Specification

| Connector No. | Connector type |
|---------------|---|
| CN-Z | 15 pin D sub-miniature Female receptacle (In accordance with SEMI-E73) |
| CN-Y | 25 pin D sub-miniature Female receptacle |

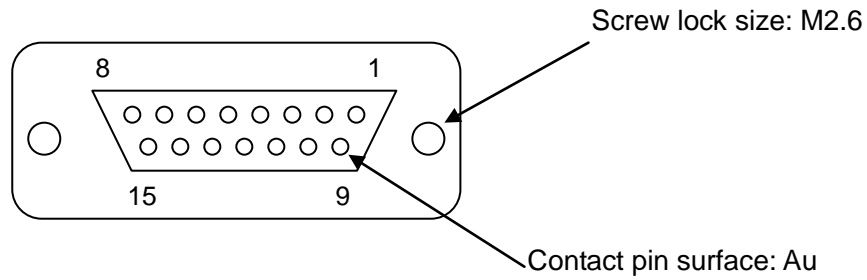

Fig. 4.6
15 Pin D Sub-Miniature Female Receptacle
 (As seen from connecting side)

Table 4.7 Control Connector Pin Assignment
(CN-Z: In accordance with SEMI-E73)

| Pin. No. | Signal name | I/O | Signal type |
|----------|---------------------|-----|-------------------------|
| 1 | MP START (+) | IN | Run:CLOSE, Alternate |
| 2 | BP START (+) | IN | Run:CLOSE, Alternate |
| 3 | MP START STATUS (+) | OUT | Run:CLOSE, Alternate |
| 4 | BP START STATUS (+) | OUT | Run:CLOSE, Alternate |
| 5 | WARNING STATUS (+) | OUT | WARNING:OPEN, Alternate |
| 6 | ALARM STATUS (+) | OUT | ALARM:OPEN, Alternate |
| 7 | REMOTE STATUS (+) | OUT | REMOTE: CLOSE |
| 8 | - | | |
| 9 | MP START (-) | | |
| 10 | BP START (-) | | |
| 11 | MP START STATUS (-) | | |
| 12 | BP START STATUS (-) | | |
| 13 | WARNING STATUS (-) | | |
| 14 | ALARM STATUS (-) | | |
| 15 | REMOTE STATUS (-) | | |

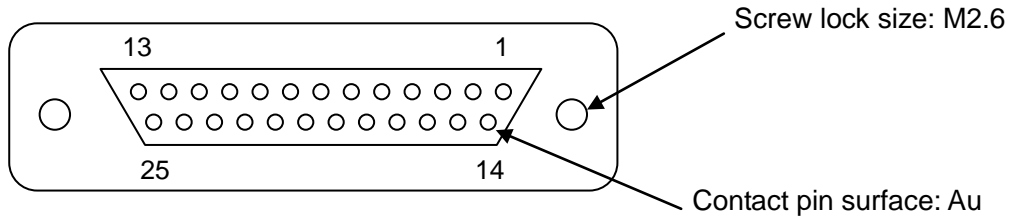

Fig. 4.7
25 Pin D Sub-Miniature Female Receptacle
 (As seen from connecting side)

Table 4.8 Control Connector Pin Assignment (CN-Y)

| Pin No. | Signal name | I/O | Signal type |
|---------|-------------------------------|-----|-------------------------------------|
| 1 | RESET (+) | IN | RESET:CLOSE |
| 2 | SAVING ENERGY CONTROL (+) | IN | SAVING ENERGY MODE:CLOSE, Alternate |
| 3 | RESERVED (+) | IN | |
| 4 | RESERVED (+) | IN | |
| 5 | RESERVED (+) | IN | |
| 6 | EMS STATUS (+) *1 | OUT | EMS:OPEN, Alternate |
| 7 | PUMP N2 WARNING STATUS (+) *2 | OUT | Abnormality:CLOSE, Alternate *3 |
| 8 | RESERVED (+) | OUT | |
| 9 | SAVING ENERGY STATUS (+) | OUT | SAVING ENERGY MODE:CLOSE, Alternate |
| 10 | RESERVED (+) | OUT | |
| 11 | RESERVED (+) | OUT | |
| 12 | RESERVED (+) | OUT | |
| 13 | - | | |
| 14 | RESET (-) | | |
| 15 | SAVING ENERGY CONTROL (-) | | |
| 16 | RESERVED (-) | | |
| 17 | RESERVED (-) | | |
| 18 | RESERVED (-) | | |
| 19 | EMS STATUS (-) *1 | | |
| 20 | PUMP N2 WARNING STATUS (-)*2 | | |
| 21 | RESERVED (-) | | |
| 22 | SAVING ENERGY STATUS (-) | | |
| 23 | RESERVED (-) | | |
| 24 | RESERVED (-) | | |
| 25 | RESERVED (-) | | |

*1 : Optional

*2 : Only “P” and “N” model.

*3 : It can change to “Abnormality:OPEN, Alternate” by DIP SW. setting.

Table 4.9 CN-Z & CN-Y Signal Contacts

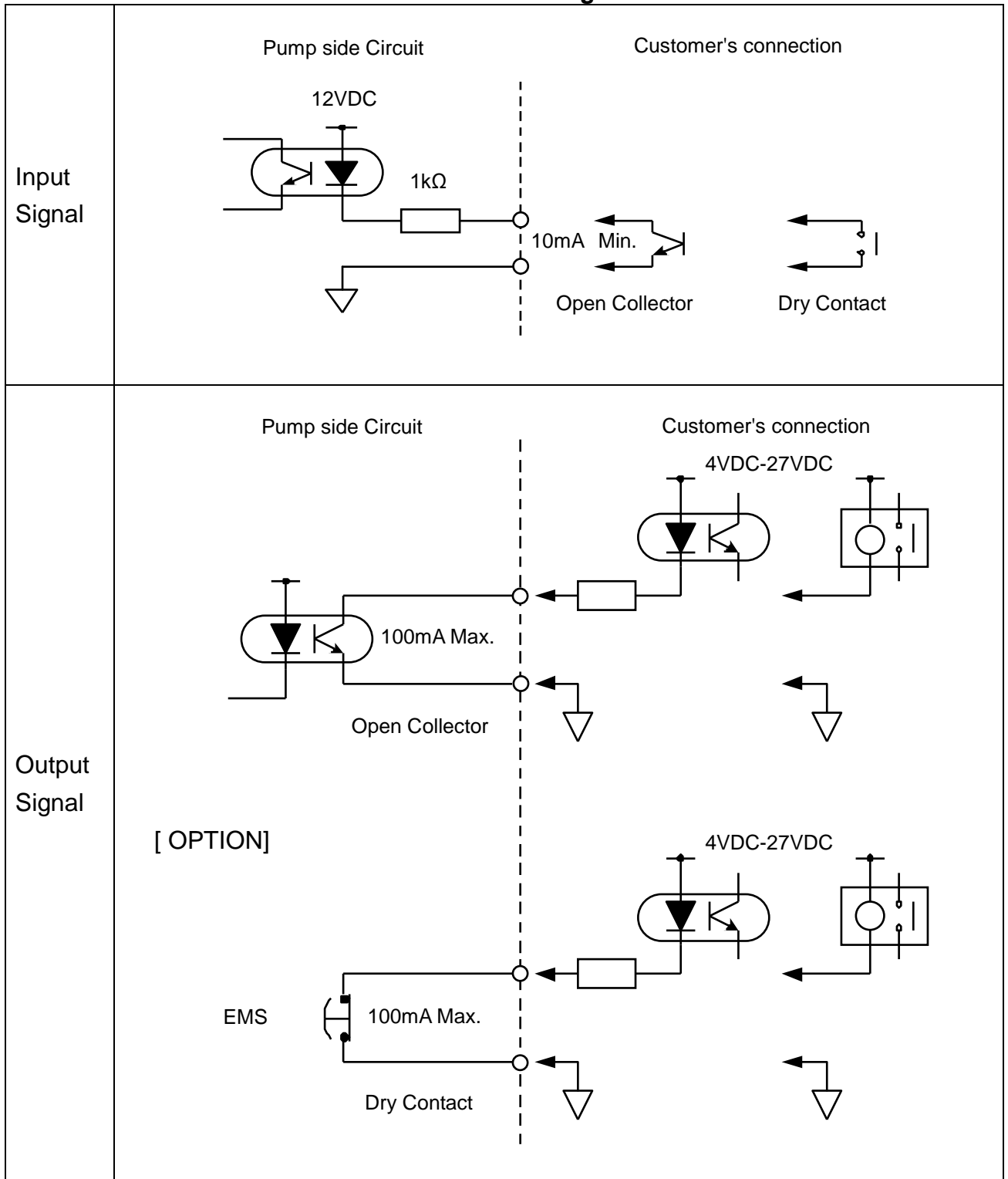

CAUTION Do not wire vacant pins.

CAUTION Apply a 12V DC power for input signals on the pump side. Do not apply this voltage on the equipment side.
The output signals are generated from an open collector output. Please use it by the equipment side, impressing the power supply of DC4V to DC27V.

CAUTION Be sure to wire all signals with the correct polarity (SIG./COM.)

CAUTION When output signals are used to energize an inductive load such as a relay, be sure to insert a diode (100V, 1A class) in order to absorb the back electromotive force due to surge currents.

4.3.3 Emergency Stop Switch Box (EMS Switch Box) – Optional

This pump has optional EMS Switch Box. Details of EMS Switch are shown as follows.

(1) Outline of function of EMS

EMS means Emergency Stop. When EMS switch is pushed and activated for emergency, pump is stopped running. This EMS switch can also work as “Emergency Off” which shut down pump power supply with additional components to be prepared by users (see section 4 for detail).

(2) EMS System Flow

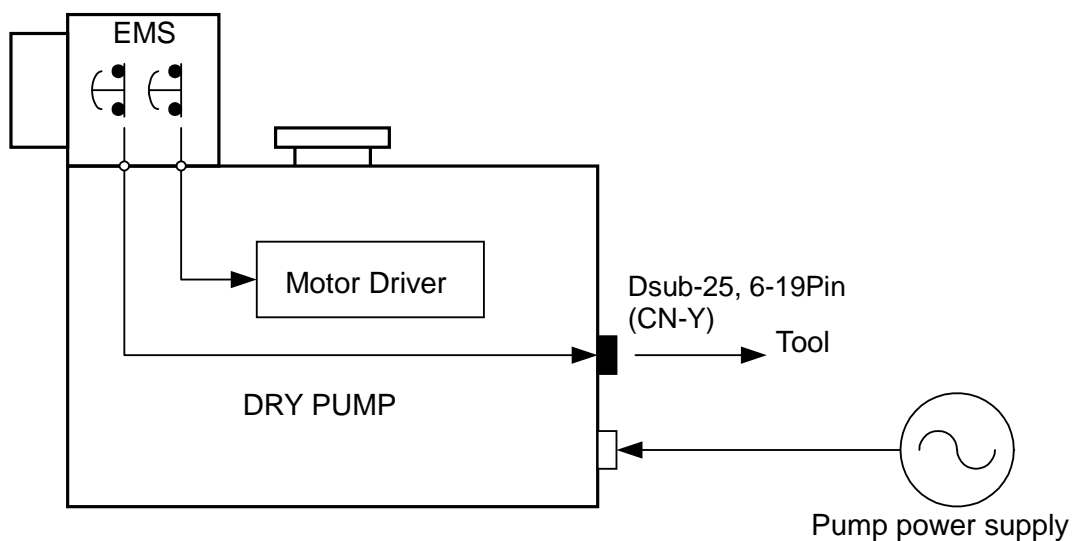

Fig. 4.8 System Flow

(3) Operation control

- Push EMS Button to stop dry pump
 Push red EMS button (Alternate)
 Motor Driver output is turned off and pump stops
 6-19 pin at Dsub-25 pins (CN-Y) Connector : Close → Open
 (See Figure 4.7 and Table 4.8)
 The following alarm is shown on LCD controller.

ALARM:
EMERGENCY STOP

- Release EMS
 Check that pump can be operated and turn the button head to release lock.
 Press the RESET button on the LCD controller, the pump to lift the status of the ALARM.

(4) Example of System Flow diagram for EMO (Emergency OFF)

This EMS switch can also work as Emergency Off (EMO, Hardware interlock to shut off the pump power supply) with additional components to be prepared by users.

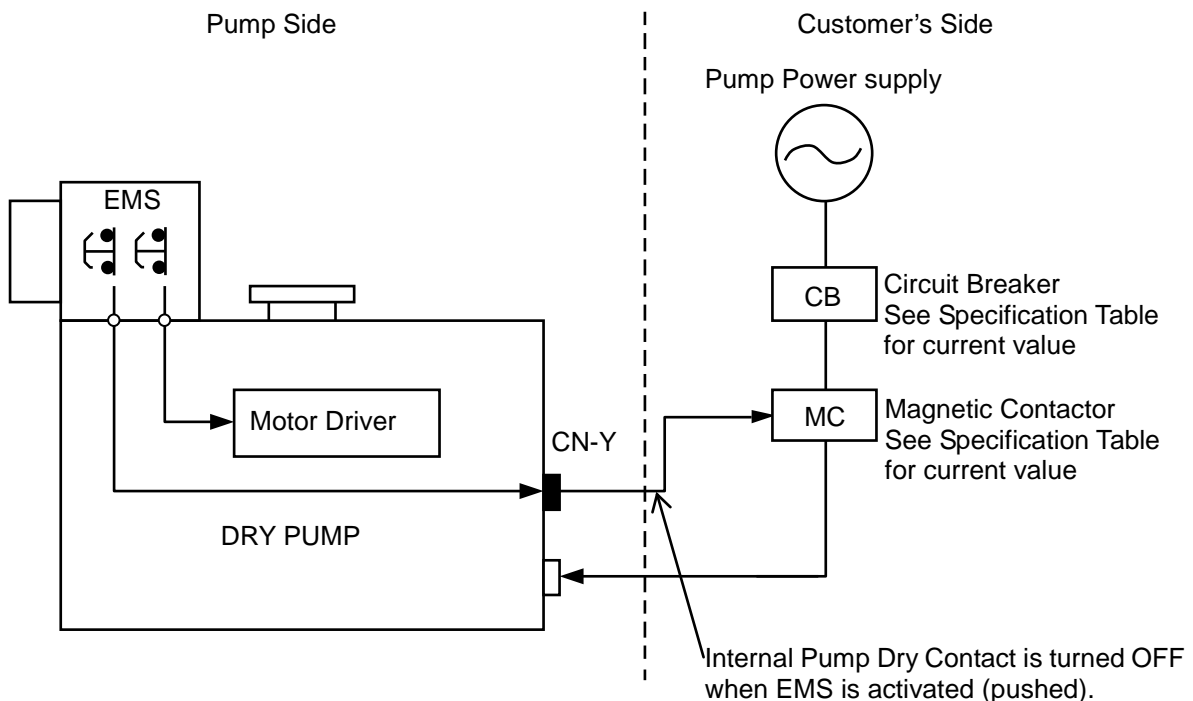

Fig. 4.9 Example, EMO System Flow

4.4 Safety interlock Connector (Connector EXT.IL)

Hard interlock signal is output as the final safety protection by EXT.IL connector.
Please intercept the power supply of the pump when Hard interlock signal is open.
(see 9. For SEMI S2 standard)

| | |
|----------------------------------|--|
| plug | HIROSE DF1B-2EP-2.5RC |
| Plug Pin (Suitable wire size) | HIROSE DF1B2022PCB (UL1007 AWG#20-22) |

4.5 Power Supply for the Options (Connector CN-C)

This Power Supply is used for the options listed below and should not be used for other purposes.

For example:

ADAPTER for Central Monitoring System

Interface Controller



DANGER Power Supply for the options is kept applying voltage during the pump is supplied the power.



WARNING Do not use the power supply for other purposes.

5. LCD Controller

5.1 LCD Outline

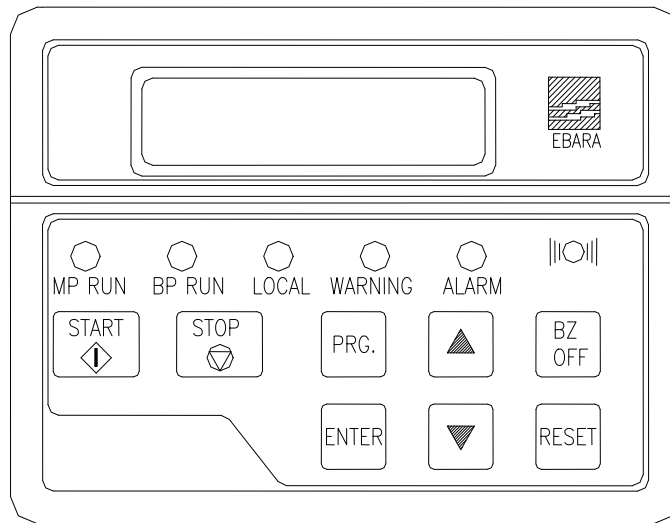

| | | |
|-----------|---------|---|
| [Buttons] | START | For start of MP and BP |
| | STOP | For stop of MP and BP |
| | ▲ ▼ | For changing LCD indication |
| | RESET | For resetting WARNING and ALARM |
| | BZ. OFF | For "buzzer mute in WARNING / ALARM " |
| | PRG. | For changing screen of pump status and Dip Switch selection |
| | ENTER | For using at DIP switch selection |
| [LED] | BP RUN | BP running (It doesn't operate in EV-S20(P/N)) |
| | MP RUN | MP running |
| | LOCAL | LOCAL mode |
| | WARNING | WARNING condition |
| | ALARM | ALARM condition |

Fig 5.1 LCD controller

5.2 LCD Indication

The operating status of the pump is displayed on the LCD of the controller.
 For details of display, see Tables 5.1.

Table 5.1 LCD controller indication

| No | ITEM | INDICATION |
|----|--|---|
| 1 | Power | B P : # # . # # k W M P : # # . # # k W |
| 2 | Control mode Pump running mode | C O N T R O L : L O C A L M O D E : N O R M A L |
| 3 | Running history (Indication of history) | P U M P R U N N I N G H I S T O R Y ? |
| 4 | Alarm history (Indication of history) | A L A R M / W A R N I N G H I S T O R Y ? |
| 5 | Pump type voltage Pump unit No. | * * * * * # # # V & & & & & & |
| 6 | Total operation time | O P E . T I M E # # # # # h |
| 7 | Back Pressure (*Optional) | B A C K P R E S S U R E # # # . # k P a |
| 8 | Pump N ₂ gas flow | P U M P N 2 F L O W # # . # P a m ³ / s |
| 9 | Cooling water flow | W A T E R F L O W # # . # L / m i n |
| 10 | Pump casing temperature | C A S I N G T E M P . # # # ° C |
| 11 | Motor speed | B P : # . # k m i n - 1 M P : # . # k m i n - 1 |
| 12 | WARNING/ALARM | \$ \$ \$ \$ \$: \$ \$ \$ \$ \$ \$ \$ \$ % \$ \$ \$ \$ \$ \$ \$ \$ \$ \$ \$ \$ \$ \$ \$ \$ \$ \$ |

1. Two control modes are available: LOCAL “(local operation)” and “REMOTE (remote operation)”.
2. Two running modes are available “NORMAL (rate operation)” and “S.ENERGY (energy-saving operation)”
3. " % " shows present number of WARNING/ALARM.
4. Upper row "\$\$\$\$\$" distinguishes between WARNING/ALARM and indicates the position where WARNING/ALARM has occurred.

Lower row "\$\$\$\$\$" displays details of WARNING/ALARM.

5. Total pump operating time gives the total hours of operation after shipment from the factory.
6. The display will return to the motor current indication when no operation takes place after the lapse of 1 minute.
7. Use the Display Select Switch (▲ ▼) to change the display.
The WARNINGS/ALARMS that have currently been generated can be displayed with the Display Select Switch.

See Fig. 5.2 for the key operation of the pump operation status display.

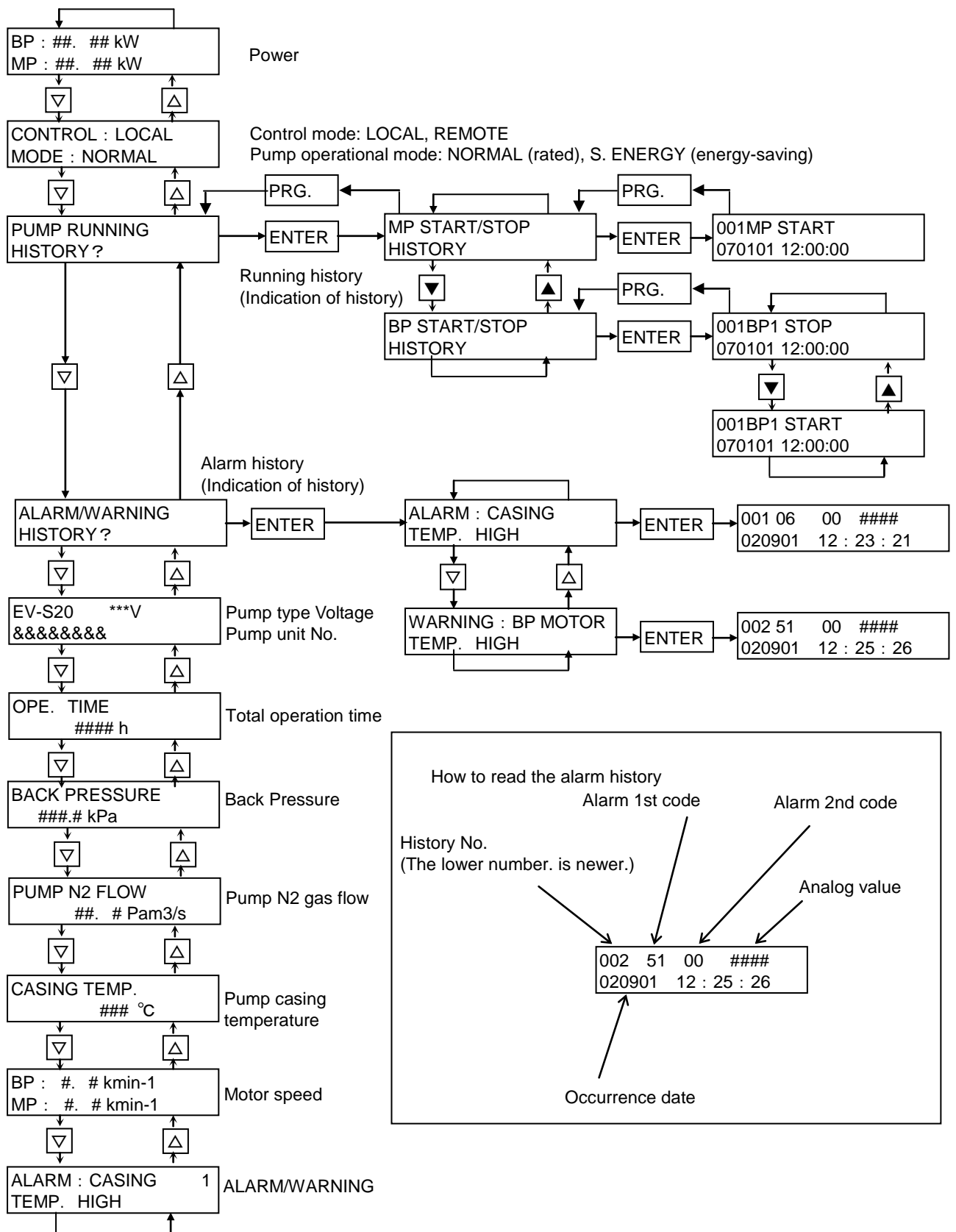

Fig. 5.2 Key operation for the pump operation status display screen

Table 5.2 Alarm code list

| ALARM name | Code | | WARNING name | Code | |
|--|----------|----------|---------------------------------------|------------------------------------|----------|
| | 1st code | 2nd code | | 1st code | 2nd code |
| MP casing temp. | 50 | 01 | Cooling water flow low | 00 | 01 |
| BP motor temp. | 51 | 00 | MP casing temp. | 05 | 01 |
| MP motor temp. | 52 | 00 | High board inner temp. | 13 | 00 |
| Water Leakage (▲) | 53 | 00 | Pump N2 flow low | 18 | 01 |
| Emergency Stop(▲) | 59 | 00 | Back pressure high (▲) | 21 | 01 |
| Back pressure high (▲) | 63 | 00 | Back pressure wire broke (▲) | | 02 |
| Power failure | 64 | 00 | BP motor temp. | 23 | 00 |
| MP's driver protective circuit activated (OC) | 65 | 01 | MP motor temp. | 24 | 00 |
| MP's driver protective circuit activated (OV) | | 02 | Inner communication error (MP driver) | 26 | 01 |
| MP's driver protective circuit activated (OH1) | | 04 | | | 02 |
| MP's driver protective circuit activated (OH2) | | 05 | | | 03 |
| MP's driver protective circuit activated (CPF) | | 06 | | | 04 |
| BP's driver protective circuit activated (OC) | | 66 | 01 | Inner communication error (AI) (▲) | 26 |
| BP's driver protective circuit activated (OV) | 02 | | | | |
| BP's driver protective circuit activated (OH1) | 04 | | | | |
| BP's driver protective circuit activated (OH2) | 05 | | | | |
| BP's driver protective circuit activated (CPF) | 06 | | | | |
| BP overload 2 | 67 | | 00 | | |
| MP overload 2 | 68 | 00 | | | |
| BP step out | 69 | 00 | | | |
| MP step out | 70 | 00 | | | |
| Cooling water flow low | 73 | 00 | | | |
| Motor thermostat | 81 | 00 | | | |
| Inner communication error (MP driver) | | 01 | | | |
| Inner communication error (IO) | | 02 | | | |
| Inner communication error (BP driver) | | 03 | | | |
| MP Driver Gate OFF | | 20 | | | |
| BP Driver Gate OFF | | 21 | | | |

The mark “▲” indicates the item is optional.

5.3 Setting the operational mode

This section describes how to set the operational mode. In the normal state, the LCD controller displays pump status. To display the operational mode setting screen, press the key "PRG" for three seconds or longer. Pressing the key for one second or longer again returns to the pump status display screen. Table 5.3 below shows indications and the details of the operational mode setting.

Table 5.3 Operational mode setting screen

| Item | Indication | Description |
|--|-------------------------------|---|
| Setting the pump operation control mode | SET CONTROL MODE? | Switches the control modes: local and remote. |
| Setting the DIP switch | SET DIP SW? | Performs the DIP switch settings (see 6.4). |
| Setting the pump running mode | SET RUNNING MODE? | Switches the running modes: NORMAL and S. ENERGY. |
| Setting the rotational speed in the NORMAL mode | SET NORMAL SPEED? | Sets the pump rotational speed in the NORMAL mode. |
| Setting the rotational speed in the S. ENERGY mode | SET S.ENERGY SPEED? | Sets the pump rotational speed in the S. ENERGY mode. |
| Pump N ₂ WARNING setting | SET POINT PUMP N2 WARNING? | Sets the WARNING value for N ₂ flow. |
| Setting the Back pressure high warning threshold | SET POINT BACK PRES.? | Set the Back pressure high warning threshold |

Keys work as below for the setting screen.

- START : Valid
- STOP : Stops the pump.
- RESET : Resets WARNING and /or ALARM.
- BZ.OFF : Switches the DIP switch No.
- ▲ : Sets the DIP switch to ON. Switches the display of the operational mode setting screen.
- ▼ : Sets the DIP switch to OFF. Switches the display of the operational mode setting screen.
- ENTER : Determines the selected setting.

See Fig. 5.3 for how to set the operational modes.

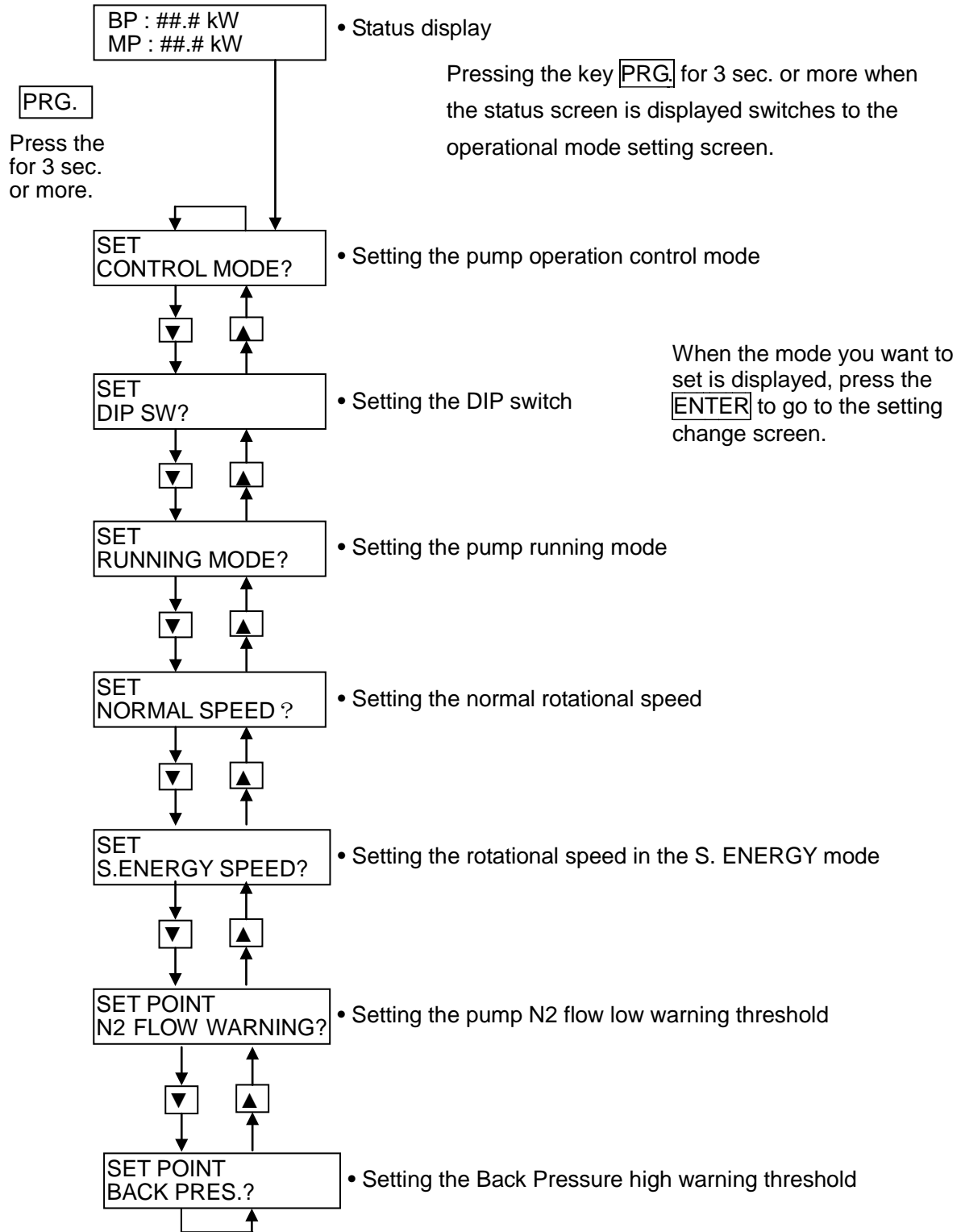
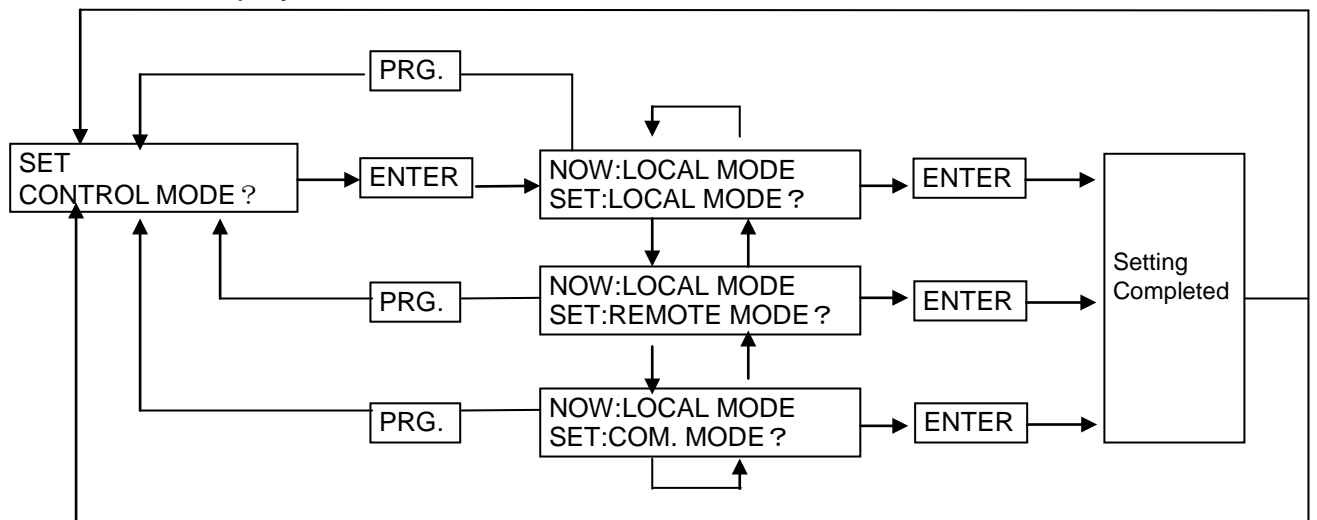

Fig. 5.3 How to set the operational mode

5.3.1 Setting the pump operation control mode

A case of display if Local mode selected.



- REMOTE MODE : Enables the remote operation
(start/stop with external signals)
- LOCAL MODE : Enables the local operation
(start/stop with the LCD controller)
- COM MODE : Enables the communication operation
(start/stop with RS232C communication)

The mode which is currently not set is displayed.

If you do not need to set, press **PRG.** key to go back to the previous screen.

5.3.2 Setting the DIP switch

The up and down arrow keys, “▲” and “▼,” turn On and OFF the DIP switch.
The key **BZ.OFF** switches the selection from 1 to 8.

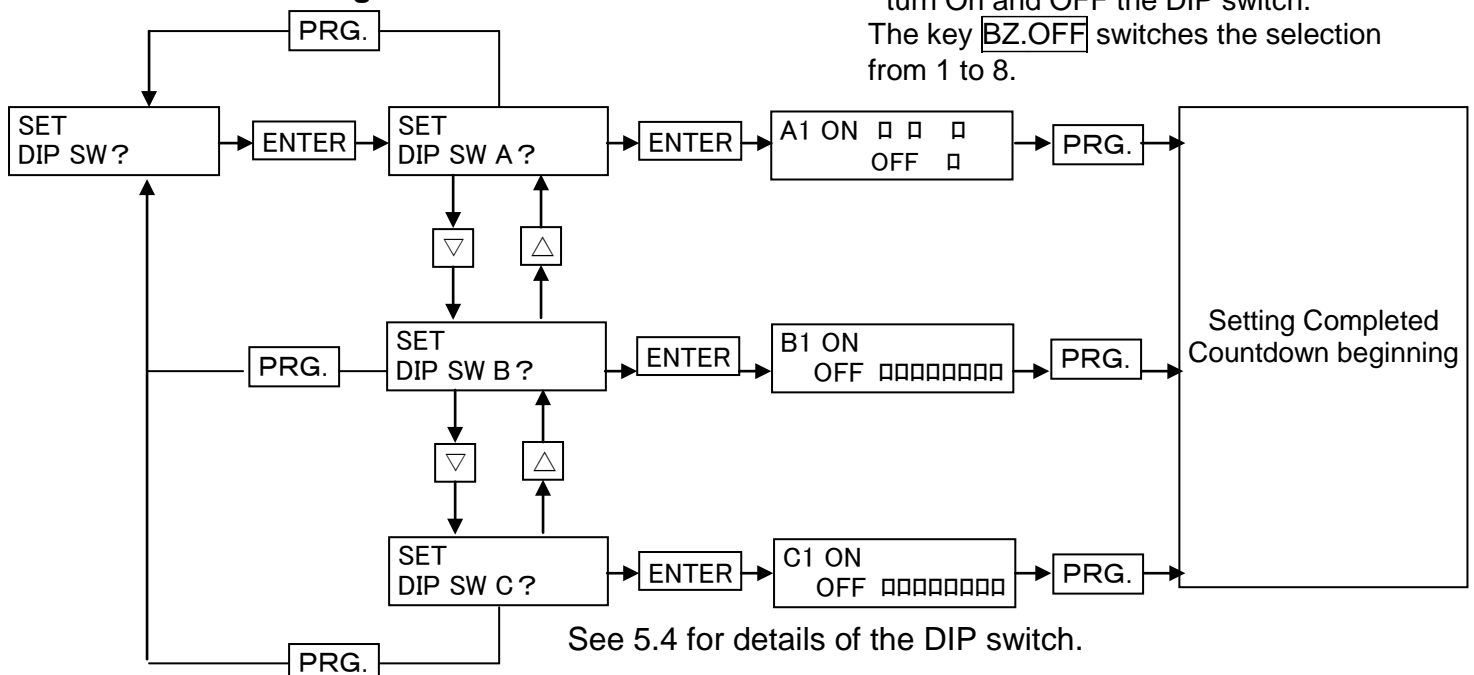

See 5.4 for details of the DIP switch.

5.3.3 Setting the pump running mode

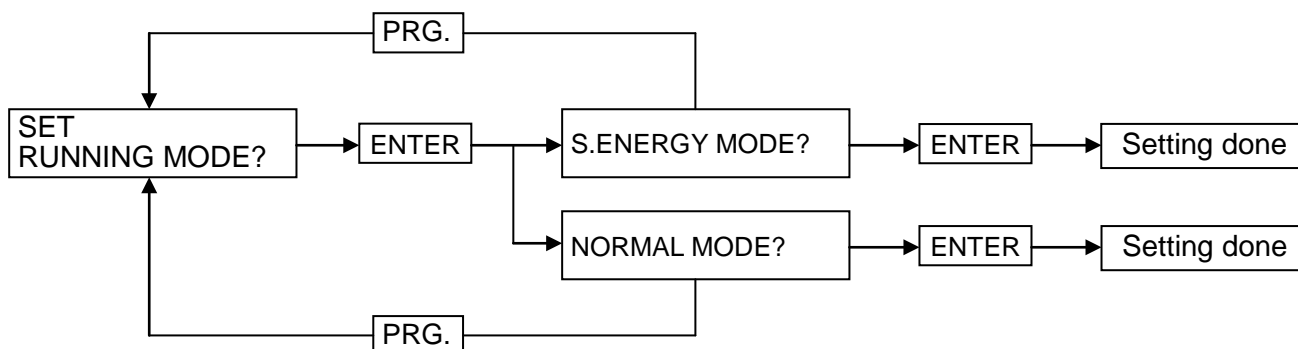

S.ENERGY MODE: Enables the energy-saving operation

NORMAL MODE: Enables the rated operation.

The mode which is currently not set is displayed.

If you do not need to set, press the key

PRG. to go back to the previous screen.

5.3.4 Setting the rotational speed in the Normal mode

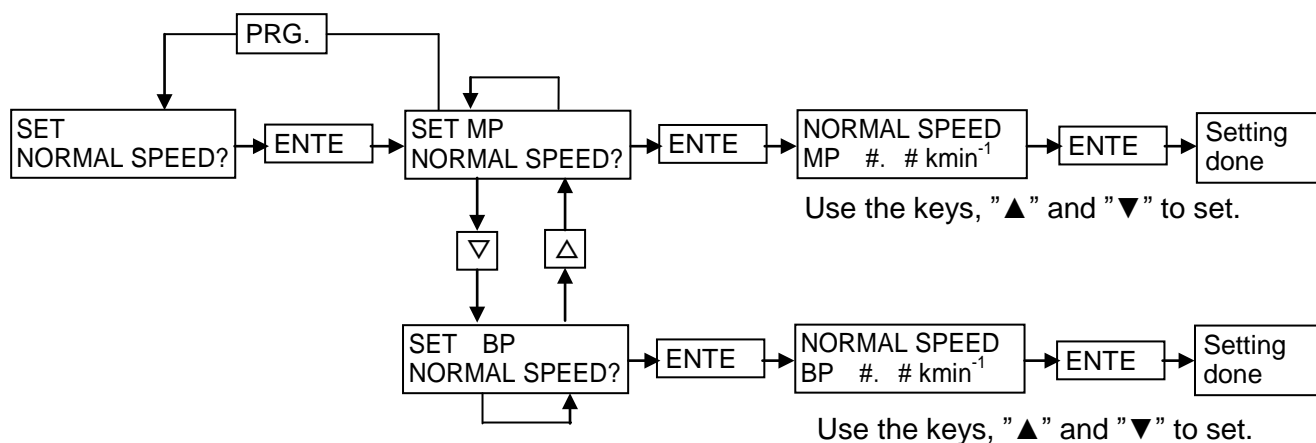

▲ ▼ Use the up and down arrow keys to change the setting value.

▲: Increase the setting speed by 0.1 kmin^{-1} .

▼: Decrease the setting speed by 0.1 kmin^{-1}

Upper limit MP/BP: The value lower than the set value for the rated speed

Lower limit MP/BP: 4.0 kmin^{-1}

5.3.5 Setting the rotational speed in the S. ENERGY mode

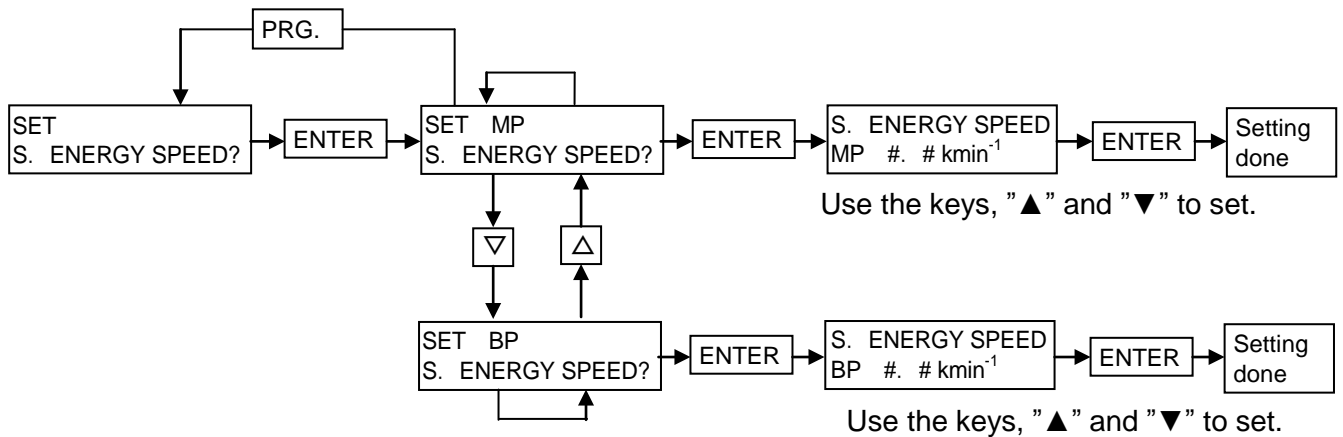

△ ▽ Use the up and down arrow keys to change the setting value.

△ : Increase the setting speed by 0.1 kmin⁻¹.

▽ : Decrease the setting speed by 0.1 kmin⁻¹

Upper limit MP/BP : The value lower than the set value for the rated speed

Lower limit MP/BP : 1.0 kmin⁻¹

5.3.6 Setting the pump N2 flow low warning threshold

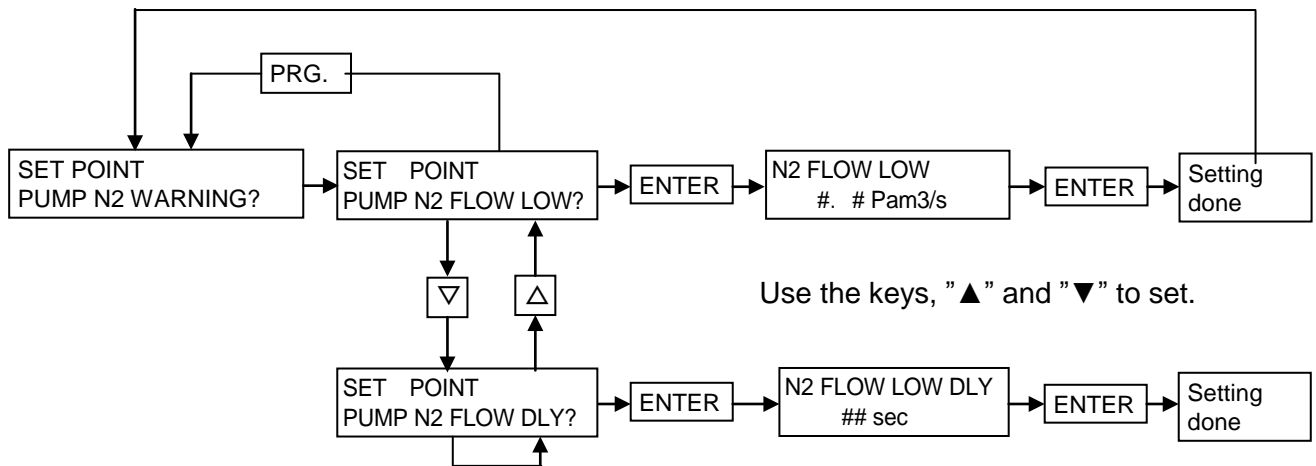

△ ▽ Use the up and down arrow keys to change the setting value.

△ : Increase the setting speed by 0.1 Pam³/s (Delay time: 1 sec)

▽ : Decrease the setting speed by 0.1 Pam³/s (Delay time: 1 sec)

Upper limit : 81.0 Pam³/s (Delay time: 60 sec)

Lower limit : 0.5Pam³/s (Delay time : 5 sec)

5.3.7 Setting the Back Pressure high warning threshold

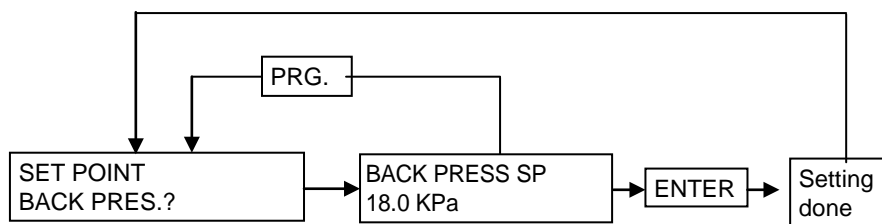

Use the keys, "▲" and "▼" to set.

▲ ▼ Use the up and down arrow keys to change the setting value.

▲ : Increase the setting speed by 0.5 kPa

▼ : Decrease the setting speed by 0.5 KPa

Upper limit : 30.0 KPa

Lower limit : 5.0 KPa

5.4 Dip Switch

Set the dip switches to select the operating modes as shown in Table 5.4 / 5.5 / 5.6.

Table 5.4 Dip Switch-A Settings

| No. | Mode | Off | On |
|-----|-------------------------------|---------------------|-----------------------|
| 1 | Data length | 7 bits | 8 bits |
| 2 | Cooling water & N2 monitoring | Constant | Only during operation |
| 3 | Buzzer | Not used | Used |
| 4 | Operation switched to Remote | According to signal | PUMP STOP |
| 5 | ----- | ----- | ----- |
| 6 | ----- | ----- | ----- |
| 7 | Dil N2 mode | Standard mode | Dil N2-0 mode |
| 8 | BP start mode | Automatic | Manual |

Table 5.5 Dip Switch-B Settings

| No. | Mode | Off | On |
|-----|-----------------------|----------------------|----------------------|
| 1 | MP Speed control | Not used | Used |
| 2 | BP Speed control | Not used | Used |
| 3 | ----- | ----- | ----- |
| 4 | ----- | ----- | ----- |
| 5 | ----- | ----- | ----- |
| 6 | Remote Interface (IF) | Exclusive special IF | No use / standard IF |
| 7 | ----- | ----- | ----- |
| 8 | LCD screen initialize | Carry out initialize | Do not initialize |

Table 5.6 Dip Switch-C Settings

| No. | Mode | Off | On |
|-----|------------------------------|-------------|--------------|
| 1 | Outputs the pump N2 warning. | Normal Open | Normal Close |
| 2 | ----- | ----- | ----- |
| 3 | ----- | ----- | ----- |
| 4 | ----- | ----- | ----- |
| 5 | ----- | ----- | ----- |
| 6 | ----- | ----- | ----- |
| 7 | ----- | ----- | ----- |
| 8 | ----- | ----- | ----- |

DIP SW-A. No.1 This switch allows you to select the data length out of 7 or 8 bits for the pump running status monitoring with the RS232C communication port.

-
- DIP SW-A. No. 2 This switch allows you to select out of “Constant” or “Only during operation ” for the cooling water and N₂ monitoring. When “Only during operation” is selected for the cooling water monitoring, monitoring will be continued for 15 minutes after the pump operation has stopped for cooling the pump. Note that the N₂ purging is recommended to continue during the pump stoppage as well because it will reduce accumulation of by-products and corrosion of the pump.
- DIP SW-A. No. 3 This switch allows you to select whether an acoustic alarm (buzzer) should be sounded or not when a WARNING/ALARM signal has been generated.
- DIP SW-A. No. 4 This switch allows you to select "According to Signal" or “PUMP STOP” when this switch is moved from the LOCAL to the REMOTE position. When the former is selected, the pump is started/stopped in response to the external start signal. When the latter is selected, the pump is stopped regardless of the external signal.

[NOTE] You can change the setting of No. 3 (Buzzer) and this switch anytime. When the settings other than No. 3 are changed, the LCD controller starts counting down from 10 seconds right after the setting change, which is similar to the situation when the power is on.

- DIP SW-A. No. 7 (dip switch-A No. 7 lets you select whether dilution N₂ gas is used or not. Set dip switch-A No. 7 to ON when the production process does not lead to the formation of reaction by-products in the pump or when the process uses non-corrosive gases. Then close the N₂ gas selector valve to save N₂ gas. Be sure always to use the N₂ gas selector valve and dip switch-A No. 7 in combination.

[NOTE] The N₂ gas selector valve is positioned on the right panel when viewing facing the utility side of the pump.

[NOTE] It takes ten odd seconds until the flow has stabilized after you have operated the N₂ gas selector valve.

DIP SW-A. No. 8 When dip switch-A No. 8 has been set to the REMOTE (Remote Operation) position, it is possible to operate the Booster Pump (BP) by selecting "AUTOMATIC Operation" or "START/STOP in Response to External Signal Input."

DIP SW-B. No. 1 When you control MP speed by external signal, set dip switch-B No.1 to ON.

DIP SW-B. No. 2 When you control BP speed by external signal , set dip switch-B No.2 to ON.

DIP SW-B. No.6 Activate or inactive the special interface.
· Set this to OFF to activate the interface (optional).
· Set this to ON to inactivate the interface (default).

[NOTE] With this switch set to OFF, signal output from the control signal connectors (CN-Z and CN-Y) that are directly connected to the pump is prevented although that from the special interface is allowed.

DIP SW-B. No.8 Locks or unlocks the currently selected operation status display, which usually returns to the power display in 60 seconds.

DIP SW-C. No.1 This switch allows you to select "NORMAL OPEN" or "NORMAL CLOSE" for PUMP N₂ WARNING output.

5.5 DIP Switch setting display

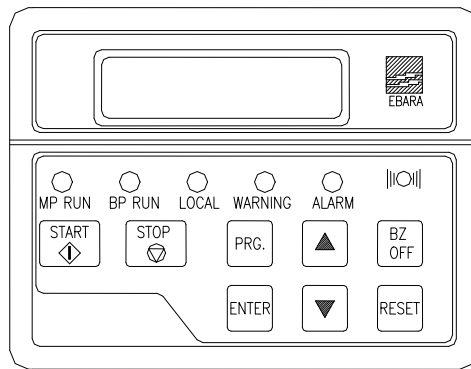

Fig 5.4 LCD controller

Key functions will be as follows on the setting display.

- START : Invalid
- STOP This stops pump operation.
- RESET This resets warning and alarm.
- BZ.OFF This switches the dip switch numbers.
- ▲ This sets the selected dip switch ON.
- ▼ This sets the selected dip switch OFF.
- ENTER Move display level. Or indicate set up conditions.

DIP Switch-A

| | | | | | | | | | |
|-----|-----|--------------------------|--------------------------|--------------------------|--------------------------|--------------------------|--------------------------|--------------------------|--------------------------|
| A * | ON | | | | | | | | |
| | OFF | <input type="checkbox"/> | <input type="checkbox"/> | <input type="checkbox"/> | <input type="checkbox"/> | <input type="checkbox"/> | <input type="checkbox"/> | <input type="checkbox"/> | <input type="checkbox"/> |

DIP Switch-B

| | | | | | | | | | |
|-----|-----|--------------------------|--------------------------|--------------------------|--------------------------|--------------------------|--------------------------|--------------------------|--------------------------|
| B * | ON | | | | | | | | |
| | OFF | <input type="checkbox"/> | <input type="checkbox"/> | <input type="checkbox"/> | <input type="checkbox"/> | <input type="checkbox"/> | <input type="checkbox"/> | <input type="checkbox"/> | <input type="checkbox"/> |

* indicates the dip switch number (1 to 8) currently you are setting.

Fig 5.5 DIP Switch

[NOTE] Duration of pump operation, dip switches, except A-3 (BUZZER) and B-8 (Initializes the LCD screen), can not be used for parameter setting.

[NOTE] When parameter setting of the dip switches, other than dip switch-A No.3 (BUZZER) and B-8 (Initializes the LCD screen), is performed, the LCD controller counts down 10 seconds, the same as at the power on state, right after the completion of the parameter setting.

[NOTE] If any warning or alarm occurs during the parameter setting, the setting session will be stopped automatically and the display will be changed to the warning & alarm display screen.

The dip switch setting at the time of shipment from the factory are as follows.

| | | |
|-------------------------------|---|----------------------|
| Data length | : | 8bits |
| Cooling water & N2 monitoring | : | Constant |
| BUZZER | : | USE |
| Operation switched to Remote | : | According to signal |
| DILUTION N2 mode | : | Standard |
| BP Operation in Remote | : | Automatic Operation |
| MP SPEED CONTROL | : | Not used |
| BP SPEED CONTROL | : | Not used |
| Remote IF | : | Not used |
| LCD screen initialize | : | Carry out initialize |
| Output the pump N2 warning | : | Normal Open |

5.6 Starting/stopping the pump with the LCD controller

Maximum two LCD controllers can be connected. Note only one of them can start and stop the pump (the other shows the pump operational statuses).

The controller of which LED "LOCAL" is lit on has precedence over the other to control the start and stop operation.

If only one controller is connected, the controller starts and stops the pump.

| | One controller connected | Two controller connected |
|------------|--------------------------|---|
| START/STOP | Allowed | The one with its LED "LOCAL" lit on is allowed. |

When you use two LCD controllers, disconnect the one which you will not use for the operation from the pump once. Then, attach it again.

6. Operation

6.1 Before Starting

- (1) Turn on the cooling water supply and check that there are no leaks at the pipe connections.

 **CAUTION** Without sufficient cooling water, the pump temperature will rise and problems such as rotor contact will occur.

[**NOTE**] The pump unit itself has no cooling water flow adjustment valve.

- (2) Turn on the N₂ gas supply. (Only MODEL EV-S**P / MODEL EV-S**N)
Check that the regulator attached to the pump is closed. (It is closed when the pressure adjustment knob is fully turned in the counterclockwise direction.)
Open the main valve and check that there are no N₂ gas leaks from the pipe connections.
Slowly turn the pressure adjustment knob clockwise to set the pressure (gauge pressure) to 0.05 MPa first. Then press the red stopper to lock the knob in position.

 **WARNING** Be sure to purge with N₂ gas in order to prevent corrosion and reduce the formation/deposition of reaction by-products in the pump. When inflammable and/or toxic gases are diluted with N₂ to the safe concentration, be sure to maintain a separate supply of N₂ gas to the pump exhaust pipe.

 **CAUTION** Abrupt rotation of the pressure adjustment knob will cause the pressure indicator needle of the regulator to wobble and result in an inaccurate pressure display.

 **CAUTION** Unless a sufficient supply of N₂ gas is maintained, serious problems will occur such as pump corrosion and accretion of reaction by-products.

Operate the N₂ gas selector valve in accordance with the dilution N₂ mode set by DIP switch-A No. 7.

If DIP Switch is set to OFF Open Valve.

If DIP Switch is set to ON Close Valve.

[Note] For normal operation, open the N₂ gas selector valve. To save N₂ gas set close the valve when the production process does not lead to the formation of reaction by-products in the pump or when the process uses non-corrosive gases.

[Note] The N₂ gas selector valve is positioned on the right panel when viewing facing the utility side of the pump.

[Note] It take 10 over seconds, until the flow has stabilized after valve operation.

(3) Turn on the power supply to the pump.



WARNING ELB is not installed in the pump unit. Please install ELB based on the law and the standard in the installation region.

(4) The LCD controller counts down 10 seconds after placing the Circuit Protector (CP) into the ON position.

[NOTE] The pump cannot start while the measuring instruments are warming up for 10 seconds after the CP is placed in the ON position.

(5) Check on the WATER FLOW display of the LCD Controller that the cooling water flow rate is 1.5L/min. or more.
(EV-S20:1.5L/min, EV-S50/S100/S200:2.0L/min)

(6) Re-check on the PUMP N₂ FLOW display of the LCD Controller that the dilution N₂ gas flow rate is within the 17 - 21Pam³/s range. Also check that the pressure gauge shows a reading of 0.09 - 0.12MPa.

After setting the pressure, press the red stopper to lock the knob in position.

In this condition, the shaft sealing N₂ flow rate is 2.0 – 2.5Pam³/s.

(The shaft sealing N₂ flow rate is contained in pump N₂ flow rate currently displayed on the LCD controller.)

(7) When the WARNING/ALARM display appears on the LCD controller or when any abnormal symptoms are found other than the display, take action in accordance with 10. "Troubleshooting."

Even when the cause of the WARNING/ALARM display has been removed, it is maintained until the RESET signal is entered. Either press the RESET button or enter an external RESET signal from the control signal connector. In the BUZZER Enabled mode using DIP switches, it is possible to stop the buzzer by pressing the BZ.OFF button when the alarm is being generated.

(8) When the pump exhaust pipe is equipped with a valve, open this valve before starting the pump.



CAUTION Problems will occur when the pump is operated with the valve closed as the exhaust pipe will be pressurized.

6.2 START/STOP

The DIP switches can be set at any time to select the REMOTE/LOCAL/COMMUNICATION modes and BUZZER Enabled function. Set in accordance with the operating conditions. (See 5.3. Setting the operational mode.)

 **WARNING** The pump and exhaust piping will remain at a high temperature during operation and for a short time after the pump has stopped.

Be sure to avoid contact and keep inflammable substances out of reach.

Do not remove the outer cover during operation.

 **CAUTION** When the production process leads to react by-products in the pump or when the process handles corrosive gases, be sure not to stop the pump until after at least 30 minutes of stopping the process gases.

 **CAUTION** Process gases will remain in the vacuum pipes and the pump even after the pump has been stopped.

Be sure therefore to purge for at least 1 hour after the pumps has been stopped.

Do not discontinue the N₂ purge when the pump is stopped only for a short time.

 **CAUTION** The pump will remain at a very high temperature event after it has been stopped. Be sure therefore to leave the cooling water on for about 1 hour after the pump has been stopped.

[**NOTE**] Do not exhaust the process gases until at least 30 minutes after the pump has been started. The pump casing temperature will stabilize after about 2 hours and it is recommended not to start exhausting the process gases earlier than this.

[**NOTE**] Do no suddenly make a pump inlet port the pressure that is higher than atmospheric pressure.

When DIP switch-A No. 4 is placed into the ON position and this switch is changed from the LOCAL to the REMOTE setting the pump will stop regardless of the external signal input.

6.2.1 LOCAL (Pump Side) Start/Stop

a) START

Press the START button on the controller.

The Main Pump (MP) will start and the MP RUN lamp on the controller will light.

After this, the Booster Pump (BP) will start automatically and the B.P. RUN lamp on the controller will light.

The current is indicated on the display during pump operation.

For other status display indications, refer to Table 6.1.

[NOTE] The pump will not start when an WARNING/ALARM has been generated. When the START button is pressed, "STARTFAIL" will appear on the display.

b) STOP

Press the STOP button on the controller. The MP and BP will stop simultaneously.

The RUN lamp goes out and the display gives a power reading of 0.0kW.

6.2.2 REMOTE Start/Stop

a) START

Enter the external "MP" start signal input from the control connector. The MP will start.

In the case of DIP SW A-8 ⇒ OFF : "MP" rotation reaches 3000 min-1, "BP" will start automatically.

In the case of DIP SW A-8 ⇒ ON : "MP" rotation reaches 3000 min-1, input the external "BP" start signal. BP will start.

The power is indicated on the display during pump operation. For other status display indications, refer to Table 6.1.

[NOTE] The pump will not start when a WARNING/ALARM has been generated. When a START signal is entered, "STARTFAIL" will appear on the display.

b) STOP

Interrupt the external MP start signal and the pump will stop.

6.2.3 COMMUNICATION Start/Stop

a) START

Input the "MP" start command from the communication connector. The MP will start.

In the case of DIP SW A-8 ⇒ OFF : "MP" rotation reaches 3000 min-1, "BP" will start automatically.

In the case of DIP SW A-8 ⇒ ON : "MP" rotation reaches 3000 min-1, input the external "BP" start signal. BP will start.

The power is indicated on the display during pump operation. For other status display indications, refer to Table 6.1.

[**NOTE**] The pump will not start when a WARNING/ALARM has been generated. When a START signal is entered, "STARTFAIL" will appear on the display.

b) STOP

Input the "MP" stop command from the communication connector. The MP will stop.

***Please refer to the COMMUNICATION SPECIFICATIONS in detail.**

6.3 Operation when momentarily power failure happens

The power failure means that power supply voltage become 15% or less than specification (170V or less). Pump operation is continued when the supply voltage is back to normal (more than 170V) within 1 second. Pump operation is stopped when the momentarily power failure is continued more than 1 second. Then control function is reset to original. (Additional new alarm/trip by to the momentarily power failure is not displayed in the LCD controller). There is a capacitor array in the control panel that will support the pump electronics through a power failure up to one (1) second in duration. Charging this capacitor array requires five (5) minutes after the pump is connected to line power. Following a momentary power failure, the capacitor array may need up to five (5) minutes to recharge ("reset") before the pump can ride through another one-second interruption in line power. There is no operator action required following a momentary power failure; the pump will recover automatically. In the momentarily power failure condition, pump rotor is driven by inertia due to interception of power supply. Thus, pumping performance may be decreased than guaranteed specification.

7. Maintenance and Inspection

7.1 Internal energies

Following items show internal energies that shall be considered before start service maintenance.

7.1.1 Power source

This pump is supplied with AC200V power source. Aside from the pump, the accessory power source locating in the vicinity of the power connectors are supplied with voltage even when the pump is completely stopped. To conduct pump maintenance or service, be sure to keep the power supply to the pump turned off and lock-outed and then unplug the power cable.

7.1.2 Cooling water

This pump is supplied with cooling water at pressure of maximum 0.4 MPa. Disconnection of the cooling water resulted from improper handling may cause electrification and unit damage. For service and transportation, unplug the cooling water connection plugs on the inlet and outlet, and seal off with plastic cap. The self-sealing plug is used for the cooling water connection plug in these pumps.

7.1.3 Nitrogen gas

This pump is supplied with nitrogen gas at pressure of maximum 0.7 MPa for diluting and sealing inside the pump. For service and transportation, close the supply-source valve to reduce the pressure with the regulator and detach the gas connection. Close nitrogen port with blank off plug. If the pump has already operated with process gases, purge the residual gases with nitrogen gas after stopping the pump operation. Then, conduct maintenance.

7.2 Routine Inspection

Check periodically that ALARM signal is not output on the LCD controller or remote output.

Table 7.1 Typical check items

| No. | Item | How to check | Interval (recommended) |
|-----|--|--------------|---------------------------|
| 1 | Motor Power | LCD | 1 time/week |
| 2 | N ₂ Gas Flow(EV-S**P / EV-S**P) | LCD | |
| 3 | Vibration / Noise | ----- | |
| 4 | Cooling water flow | LCD | |
| 5 | Pump casing Temp. | LCD | |
| 6 | Color of lubricating oil | Visual | 1 time/month |

When the WARNING/ALARM display appears, take action in accordance with Section 11. "Troubleshooting."

If the lubrication oil amount is lower than the lower limit line of the oil level gauge, supply the lubrication oil. See the section 7.4 "Lubrication oil" when adding the oil.





WARNING Switch off the power supply to the pump first and interrupt the Circuit Protector (CP) and lockout before you start on maintenance.



WARNING The pump and exhaust piping will remain at a high temperature during operation and for a short time after the pump has stopped.
Be sure to avoid contact and keep inflammable substances out of reach.
Do not remove the outer cover during operation.

Even when the cause of the WARNING/ALARM signal has been removed the signal will be maintained until the RESET signal is entered. After you have taken the remedial action, press the RESET button on the controller or enter the RESET signal from the control signal connector to reset the WARNING.

 **CAUTION** The pump will not stop when an WARNING signal is generated. When pump operation is continued in this condition an ALARM signal will be generated or a serious breakdown will occur. Be sure therefore to check the pump in accordance with the instructions of Section 10. "Troubleshooting" after the process plant has completed 1 cycle.

 **CAUTION** When a ALARM signal has been generated in the REMOTE operating mode, do not start the maintenance tasks until you have interrupted the external start signal. When the external ALTERNATE start signal input is maintained, the pump will start while the ALARM is being reset.

If any abnormal symptoms other than those displayed on the LCD controller appear, take action in accordance with the instruction of Section 10. "Troubleshooting".

When the BZ.OFF button is pressed in the BUZZER Enable mode, the buzzer will stop even during a warning status.

7.3 Vacuum and Exhaust Piping

 **WARNING** Maintenance on the vacuum and exhaust piping shall be performed by taking proper action to avoid the dispersion of inflammable, toxic and/or hazardous substances and to prevent physical contact with, and absorption of, these substances.

 **WARNING** The pump and exhaust piping will remain at a high temperature during operation and for a short time after the pump has stopped.
Be sure to avoid contact and keep inflammable substances out of reach.
Do not remove the outer cover during operation.

**WARNING**

Be sure to check for gas leaks after you have finished pipe maintenance work. Leaks will cause serious danger due to the discharge of harmful and hazardous substances and the occurrence of unpredictable reactions associated with the admission of air into the pump. When checking for gas leaks by pressurization, please pressurize by less than 0.05 MPa into the purge port and do check.

Be sure to following the instructions below when carrying out maintenance work on the vacuum and exhaust piping of the pump.

- (1) Before you remove and wash the piping be sure to purge with a sufficient volume of N₂ gas.
- (2) When an exhaust gas scrubber unit is used, close the inlet valve of the exhaust gas scrubber after the N₂ gas purge has been discontinued and then remove the piping.
- (3) Be sure to switch off the power supply.
- (4) After you have washed the piping do not reconnect until it has dried completely.

7.4 Lubricating Oil

If the oil level is lower than the lower limit line of the oil level gauge in typical check and maintenance, supply the oil is needed.

Follow the steps below to supply the oil.

- (1) Stop the pump and remove the closing board (LCD connector side) on the pump.
(See Figs. 7.1)

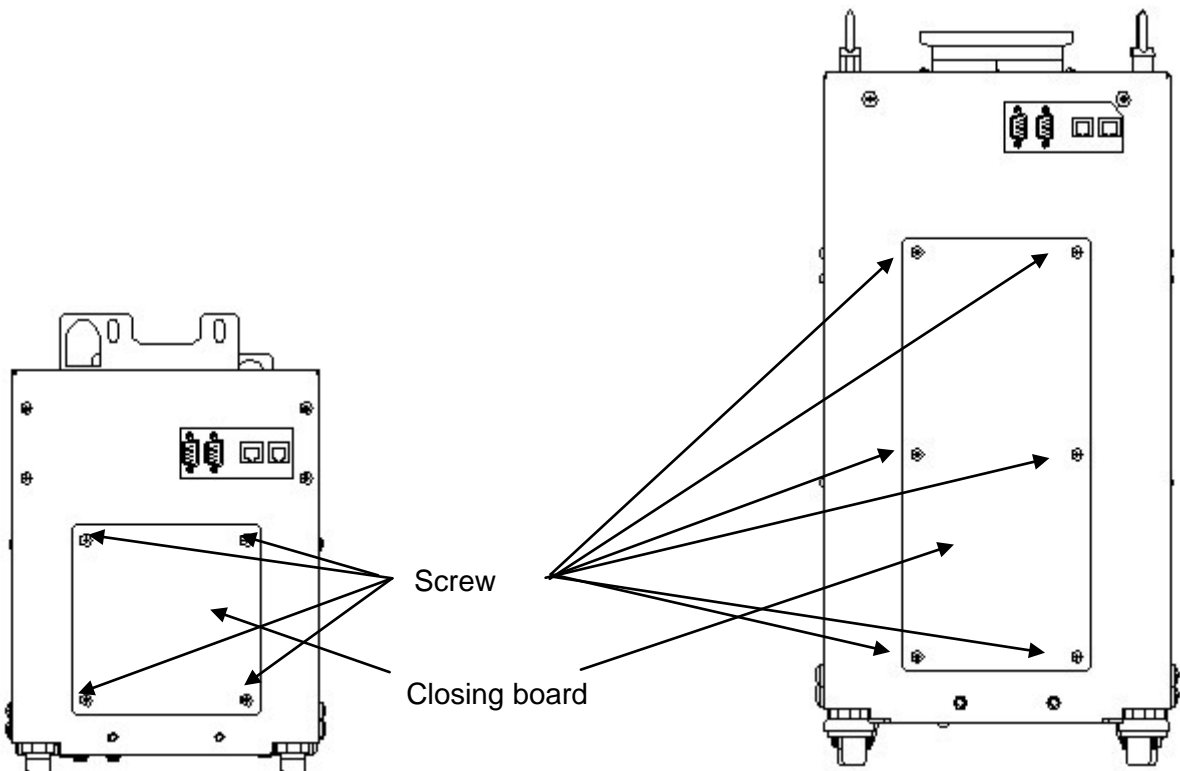

Fig. 7.1 How to remove closing board

- (2) After you have waited until the internal pump pressure returns to atmospheric (normal) pressure, remove the plug from the oil-filler inlet.
(See Figs. 7.2)
- (3) Check the level through the window of the oil level gauge. Then, add the oil so that the level is between the upper and lower limit lines (see Figs. 7.2 and 7.3).
- (4) After you have checked that there are no depositions and fragments adhering to the O ring attached to the plug, close the oil-filler inlet.
- (5) Please check the air leak after supplying lubricating oil.

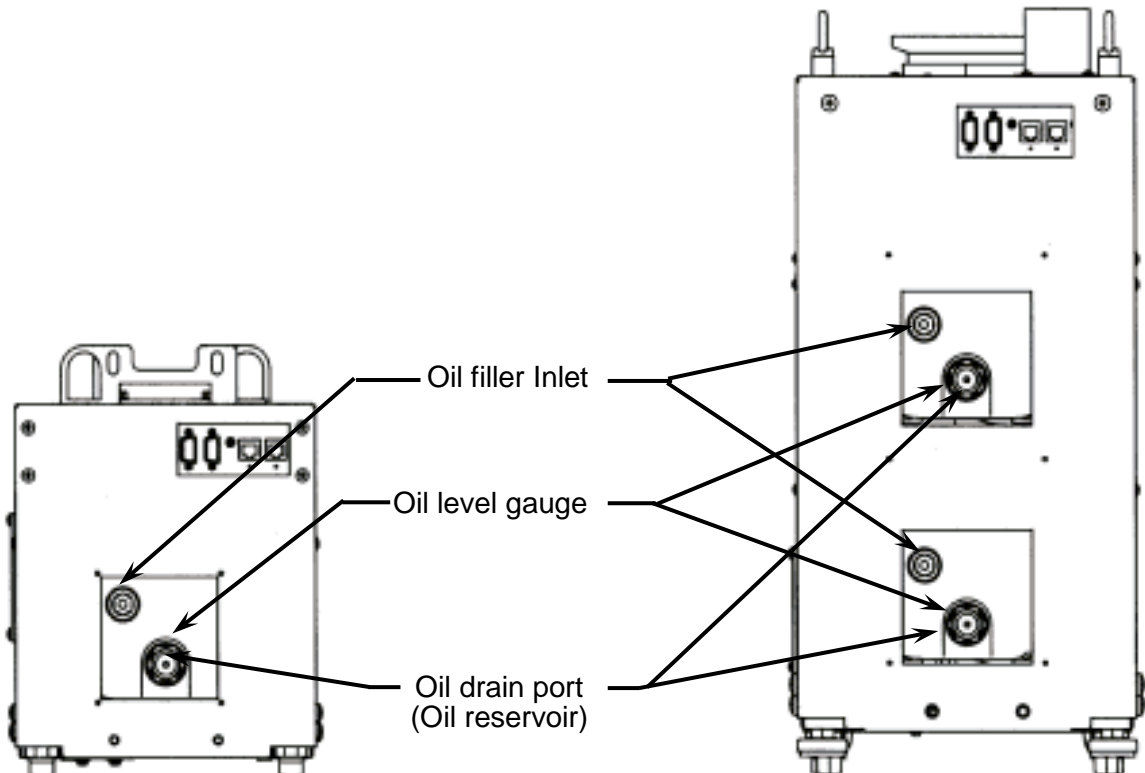

Fig. 7.2 Oil filler inlet, oil level gauge, and oil drain port positions

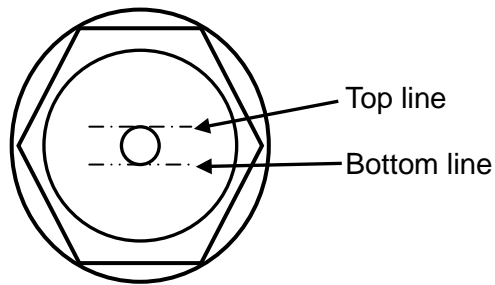



Fig. 7.3 Oil Level Gauge

CAUTION Be sure only to use the lubricant oils listed in specification table 3.1.

CAUTION Waste oil shall be disposed of by industrial waste disposal dealer in accordance with Material Safety Data sheets. (appendix1,2)

 **CAUTION** When the lubrication oil level exceeds the upper limit, the oil may leak to the pump side. Thus, be sure not to exceed the upper limit line when adding the oil.

 **CAUTION** When the lubrication oil level is lower than the lower limit line, serious failure may be caused. If you find out the shortage, add the oil immediately.

7.5 Spare (Maintenance) Parts List

Following parts are needed for maintenance in customers' site.

Table. 7.2 Spare (Maintenance) Parts List

1. Standard consumption Part.

| Parts' Name | Type | Part No. |
|----------------|------------------|-----------------|
| Ruburicant oil | BARRIERTA J100ES | C-0402-000-0111 |

2. Recommendable Spare Parts (Not needed for each pump.)

| Parts' Name | Type | Part No. |
|-----------------------------|---------------------------|-----------------|
| Oil level gauge | ----- | C-5350-000-7900 |
| Water flow sensor | 10 L/min | C-5138-107-0001 |
| N2 flow sensor * | 84.4 Pa m ³ /s | C-5300-000-5300 |
| T/C bolt | T TYPE, M8 | C-1019-121-0001 |
| N2 gas pressure regulator * | RC31886 | C-2300-000-3400 |

* for MODEL EV-S**P / MODEL EV-S**N

Following labels are attached to pump covers. When they are hard to read for discoloring or peeling off, please stick them again as directed.

Table 7.3 Labels

| Label's Name | Parts No. |
|--|-----------------|
| [DANGER] HAZARDOUS WAIGHT DANGER LABEL | C-7110-316-0001 |
| [WARNING] HAZARDOUS VOLTAGE WARNING LABEL | C-7110-313-0001 |
| [WARNING] HIGH TEMPERATURE WARNING LABEL | C-7110-312-0001 |
| [WARNING] HAZARDOUS MATERIAL WARNING LABEL | C-7110-314-0001 |
| [CAUTION] CHARGE MARK LABEL | C-7110-155-0001 |

7.6 List of wastes during maintenance

Table 7.4 lists wastes from general user maintenance. Dispose the wastes properly according to your local waste disposal regulations in each area.

Table 7.4 List of wastes during maintenance

| Part | Equipped on | Remarks |
|-----------------|---|---|
| Lubricant oil | Inside of pump module. See section 7.3. | Refer to Appendix 1,2 for Material Safety Data Sheet. |
| Lithium battery | CPU board. (No necessary to replace at usual maintenance.) | Refer to Appendix 3 for Material Safety Data Sheet. |
| O-ring | Connection of vacuum line | Usual industrial waste. |

7.7 Overhaul

Overhaul is performed in EBARA.

Contact EBARA Sales office or Overhaul service center.

Please overhaul once a year.

8. Disconnection and Transportation

 **WARNING** When the pump has been used for exhausting highly toxic gases such as arsenic and mercury compounds, be sure to contact EBARA Corporation before you return the pump.

 **CAUTION** In the interest of safety during the transportation, disassembly and cleaning of the pump, be sure to take note of the gases that have been handled.

Toxic gases may be generated from by-products in the piping or pump in pump disconnection from the tool piping for repair and replacement or flange removal for maintenance. Gain relevant information about the process gases from your tool suppliers, and be sure that the gas concentrations in the work areas are at quarter or under the acceptable values specified using appropriate measurement equipment.

Without assurance of gas safety, instruct the workers to wear proper personnel protective equipment if necessary to protect them from gas hazards. The personnel protective equipment must include at least gloves, safety goggles, and a gas mask.

To disconnect and transport the pump, proceed as follows.

- (1) Stop the pump and replace all gases inside the pump by purging them with N₂ gas.
- (2) Switch off the power supply to the pump and remove the power and signal wires.
- (3) After you have fully closed the N₂ regulator remove the N₂ pipe, seal off the N₂ purge port with a sealing flange.
- (4) Remove the cooling water pipes.
- (5) Remove the vacuum and exhaust pipes and completely seal off the suction and exhaust ports of the pump with a blind flange or similar seal. Seal off all process gas discharge points such as the differential port by using a blind flange.

[notes] Differential port is option.

- (6) Put the LCD controller on the upper part of the pump. Fix it with the tape.
- (7) Wrap the pump in a vinyl sheet.
- (8) Use the lifting brackets provided on the pump for slinging the pump to load and unload. Fasten lifting brackets completely and push in until flush with the seating surface. For sling, use a wire with a length so that the slinging angle (that is, the angled subtended by the two wires) is within 60 degrees.



DANGER Do not enter the zone underneath the suspended pump.



WARNING For lifting the pump, use only qualified operator personnel.

Be sure that the wire rope and crane used for lifting the pump are in proper order and match the weight of the pump.

To prevent unequal weight distribution, suspend the pump by ensuring that the slinging angle remains symmetrically centered.

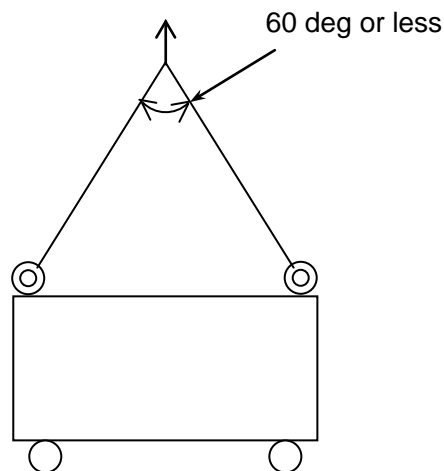

Fig. 8.1 Slings the Pump

- (9) When options such as an interface box are attached to the pump, be careful to avoid damage due to contact by the wire rope.
- (10) For transportation, secure the pump by lowering the adjustment feet. Place a protective cloth around the pump to avoid shock and position protective members between the outer cover and the wires in order to distribute the load of the fastening wires.

9. For SEMI S2 standard

Additional electrical parts required for SEMI application are shown in Table 9.1. The process tool panel may provide these items or they may appear in an auxiliary control panel mounted on the pump or remotely.

Table 9.1 Necessary parts for SEMI S2 standard

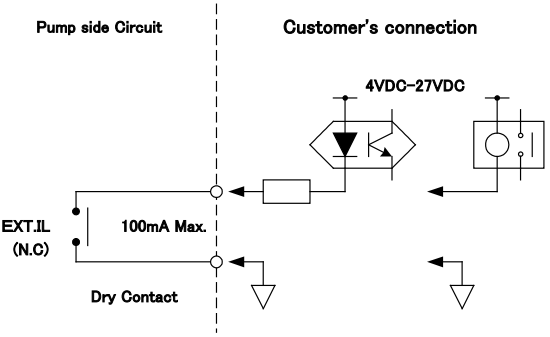
| Parts name | Conditions |
|-------------------------|--|
| CB (Circuit Breaker) | Please use CB of 10 kA or more in the breaking current capacity. (UL489 corresponding) |
| EMO (Emergency Off) | Please select it based on the law and the standard of installation features. Please intercept the power supply of the pump when EMO operates. Optional EMS Switch Button can be used as EMO Button with External CB and Magnetic Switch. |
| Safty Interlock | <p>Hard interlock signal is output as the final safty protection by EXT.IL connector. Please intercept the power supply of the pump when Hard interlock signal is open.</p>  |
| Pump Fixation | Please fix the pump to the floor or other firm ground with the brackets at the installation. |

10. Troubleshooting

**WARNING**

Interrupt Circuit Protector (CP) before starting on wiring and maintenance work.

Do not switch on the power supply to the pump until work is completed.

**WARNING**

The pump casing and exhaust piping become extremely hot during operation and for some time after stopping.

Be sure that pump and exhaust piping do not come in contact with humans or inflammable substances.

Do not remove the pump cover during operation.

**WARNING**

Check for gas leaks after installing and maintaining the piping.

Gas leaks will result in the discharge of harmful and dangerous substances and in abnormal reactions due to the ingress of air into the pump. When checking for gas leaks by pressurization, please pressurize by less than 0.05 MPa into the purge port and do check.

10.1 Troubleshooting (1) Basic trouble

| Abnormal symptom | Check Item | Corrective Action |
|--|---|---|
| Circuit Protector is activated. | Incorrect wiring | Check wiring. |
| | Short circuit | Replace or overhaul pump. |
| Nothing appears on LCD | No power supply to pump. | Check power supply. |
| | Connector is not connected. | Connect power connector. |
| | CP is not ON. | Place CP to ON. |
| | Disconnection of the LCD's connector | Connect LCD's connector |
| | Instrument failure | Replace instruments. |
| MP does not start when applying START button. | "Remote" or "COM" mode has been selected. | Set switch to "Local" mode. |
| | Start-up conditions are not satisfied. ("Startfail" is displayed.) | Satisfy all start-up conditions. |
| | Instrument failure | Replace instruments. |
| MP does not start when entering external "MP start" signal input. | "Local" or "COM" mode has been selected. | Set switch to "Remote". |
| | Start-up conditions are not satisfied. ("Startfail" is displayed.) | Satisfy all start-up conditions. |
| | Instrument failure | Replace instruments. |
| BP does not start. | BP start signal is not entered in "REMOTE" or "COM" mode. | Enter the start signal. |
| | Instrument failure | Replace Instruments. |
| Abnormal noise Excessive vibration | Adjustment feet are not applied. | Use the adjustment feet. |
| | Some object is making contact with the outer cover. | Remove the object. |
| | The fastening screws of the outer cover have worked themselves loose. | Tighten the fastening screws. |
| | Parts of the pump are damaged. | Replace or overhaul pump. |
| Vacuum pressure increase. | Accumulation of by-products in pipes. | Clean piping. |
| | N2 pressure setting is high. | Set pressure for correct value. |
| | Leak from vacuum piping. | Check piping. |
| | Accumulation of by-products in pumps. | Replace or overhaul pump. |
| **MEMORY ERROR** is displayed on LCD after activating CP or changing the dip switch setting. | None | Need "Countermeasure against electric Noise" to pump. |

10.2 Troubleshooting (2) WARNING

| Display | Symptom | Check Item | Corrective Action |
|--|---|--|---|
| WARN: WATER FLOW LOW | Water flow is reduced. | Coupler is disconnected. | Connect coupler. |
| | | Pressure is not sufficient. | Apply sufficient pressure. |
| | | Root valve is closed. | Open valve. |
| | | Water pipe is clogged. | Clean or replace piping. |
| | | Tube fittings are loosened. | Re-tighten. |
| | | Instrument failure | Replace instrument. |
| | | Outlet & inlet pipes are reverse. (flow value 0 L/min) | Connect pipes correctly. |
| WARN: PUMP N2 FLOW LOW | Pump N2 flow is reduced. | N2 port is not connected. | Connect N2 pipe fitting. |
| | | Primary pressure is insufficient. | Apply sufficient pressure. |
| | | Regulator setting value LOW. | Increase pressure setting. |
| | | N2 pipe is clogged. | Replace N2 piping. |
| | | Leaks on N2 pipe. | Check the fittings. |
| | | Instrument failure | Replace instrument. |
| WARN: CASING TEMP HIGH | Casing temperature rises. | Pump back pressure rises. | Check exhaust pipe |
| | | Increase of the gas load. | Reduce the inflow gas amount. |
| | | Accumulation of by-product | Replace or overhaul pump. |
| | | Cooling water flow is reduced. | Increase cooling water flow. |
| WARN: BP MOTOR TEMP HIGH WARN: MP MOTOR TEMP HIGH | Booster pump (BP) motor coil temp. rises. Main pump (MP) motor coil temp. rises. | Cooling water flow is reduced. | Cool pump thoroughly and reset. |
| | | Motor failure | Replace or overhaul pump. |
| WARN: BP DRIVER TEMP HIGH ##### WARN: MP DRIVER TEMP HIGH ##### | Booster pump (BP) driver temp. rises. Main pump (MP) driver temp. rises. | Cooling water flow is reduced. | Increase cooling water flow. |
| WARN: ## COMM.ERROR | Communication is not established. | Connection error of the instrumented units | Check the connection of the instrumented unit. |
| | | Instrument failure | Replace instrument. |
| WARN: PUMP BOX TEMP HIGH | Temp. rises in pump cover. | Cooling water flow is reduced. | Increase cooling water flow. |
| | | The ambient temperature is high. | Confirm the ambient temperature (less than 30°C). |
| WARN:PUMP N2 VALVE ERROR | N2 valve open. | Setting is N2 0 mode. | Close N2 valve. (at the side of pump) |

After you have taken the remedial actions above, reset the pump. If the problem that has caused the WARNING signal still remains, the WARNING display will appear again even after you have reset.

10.3 Troubleshooting (3) ALARM

| Display | Symptom | Check Item | Corrective Action |
|--|---|---|---|
| ALARM: WATER FLOW LOW | Water flow is reduced. | Coupler is disconnected. | Connect coupler. |
| | | Pressure is not sufficient. | Apply sufficient pressure. |
| | | Root valve is closed. | Open valve. |
| | | Water pipe is clogged. | Clean or replace piping. |
| | | Tube fittings are loosened. | Re-tighten. |
| | | Instrument failure | Replace instrument. |
| | | Outlet & inlet pipes are reverse. (flow value 0 L/min) | Connect pipes correctly. |
| ALARM: CASING TEMP H.HIGH | Pump casing temp. rises. | Pump back press. rises. | Check exhaust pipe. |
| | | Increase of the gas load. | Reduce the inflow gas amount. |
| | | Cooling water flow is reduced. | Cool pump thoroughly and reset. |
| | | Accumulation of by-products | Replace or overhaul pump. |
| ALARM:BP MOTOR TEMP H.HIGH ALARM:MP MOTOR TEMP H.HIGH | Booster Pump (BP) motor coil temp. rises. Main Pump (MP) motor coil temp. rises. | Cooling water flow is reduced. | Cool pump thoroughly and reset. |
| | | Motor failure | Replace or overhaul pump. |
| ALARM:BP MOTOR OVERLOAD 2 ALARM:MP MOTOR OVERLOAD 2 | BP motor current rises. MP motor current rises. | Pump back press. rises. | Check exhaust pipe & silencer. |
| | | Increase of the gas load. | Reduce the inflow gas amount. |
| ALARM:BP MOTOR STEP OUT ALARM:MP MOTOR STEP OUT | Booster Pump (BP) motor step out. | Rotor makes contact. (Accumulation of by-products) (Substance plunge) | Replace or overhaul pump. |
| | | Instrument failure | Replace instrument. |
| | Main Pump (MP) motor step out. | Pump back press. rises. | Check exhaust pipe. |
| | | Increase of the gas load. | Reduce the inflow gas amount. |
| Can not restart. | Instrument failure | Replace instrument. | |
| ALARM: BP DRIVER ### ALARM: MP DRIVER ### | BP Motor driver protection | Pump back press. rises. | Check exhaust pipe. |
| | | Increase of the gas load. | Reduce the inflow gas amount. |
| | MP Motor driver protection Can not restart | Rotor makes contact. (Accumulation of by-products) (Substance plunge) | Replace or overhaul pump. |
| | | Cooling water flow rate is reduced. | Cool pump thoroughly and reset. |
| | | Motor driver has broken down. | Replace motor driver. |
| | | Instrument failure | Replace instrument. |
| ALARM: PHASE ERROR | Open phase | Incorrect wiring | Check power supply |
| | | Instrument failure | Replace instrument. |
| ALARM:STARTFAIL ALARM/WARN EXIST | Start fault | Starting during WARNING/ALARM status | Make sure that all starting conditions are met. |
| | | Instrument failure | Replace instrument. |

After you have taken the remedial actions above, reset the pump. If the problem that has caused the WARNING signal still remains, the WARNING display will appear again even after you have reset.

10.4 Troubleshooting (4) Option

| Display | Symptom | Check Item | Corrective Action |
|----------------------------|-------------------------|---------------------------------------|---|
| ALARM: WATER LEAKAGE | Water leakage | Tube fittings are loosened. | Re-tighten. |
| | | Instrument failure | Replace instrument. |
| ALARM : BACK PRESS.HIGH | Exhaust pressure rises. | Exhaust valve is closed. | Check exhaust pipe. |
| | | Accumulation of by-products in pipes. | Check exhaust pipe. |
| | | Instruments failure | Replace instruments. |
| WARN: PRESS.HIGH ##.# | Exhaust pressure rises. | Exhaust valve is closed. | Check exhaust pipe. |
| | | Accumulation of by-products in pipes. | Check exhaust pipe. |
| | | Instruments failure | Replace instruments. |
| ALARM: EMERGENCY STOP | Emergency Stop switch | Stop by emergency Stop button. | Check that pump can be operated and turn the button head to release lock. |

After you have taken the remedial actions above, reset the pump. If the problem that has caused the ALARM signal still remains, the ALARM display will appear again even after you have reset.