

Document No. ME_CT_ETC76_(CN)_R0

Chemtech Scientific provides access to this content as a courtesy.
We do not own the content contained in this document.
All rights and credit go directly to its rightful owners.
www.chemtechsci.com
Call us at: 484-424-9415



Instructions Manual

Controller ETC76

Be sure to read and understand all warnings in this manual before using the product.

Keep this manual readily available for reference.





Safety



This section provides important safety information. Be sure to read this section thoroughly before using the compound molecular pump EBT70F-20 and the controller ETC76, and follow all instructions.

Note that the scope of the cautions and warnings in this manual are limited to the range of our expectation. For your safety, follow all general rules (laws and regulations) in addition to the instructions provided herein.

EBARA reserves the right to make changes to the product specifications without notice, so as to maintain and improve the quality of the product. For this reason, the contents of this manual may not match exactly with the actual product.

Symbols and Definitions

The following symbols and definitions are used for the warnings and cautions in this manual.

 Warning	Important information for preventing serious bodily injuries. Failure to follow instructions labeled with this symbol may result in death or serious injury.
 Caution	Important information for safe use of the controller. Failure to follow instructions labeled with this symbol may result in injury and/or property damage.
 Information	Information that may be useful when using the controller.

 Warning	Instructions Manual
	This instructions manual (hereinafter, "this manual") provides safety notes, operation procedures, and maintenance and inspection procedures for the controller. All personnel must read and understand the contents of this manual, and handle the controller appropriately.

 Warning	Input power
	Input power voltage is AC100-230V. Supply the power excluding noise, surge and voltage fluctuation to the controller.

 Warning	Combination of the controller and the pump.					
	Match the controller with the correct pump. The nameplate is stuck on the side panel of the controller at shipping from our company.					
	<table border="1" style="width: 100%;"> <tr> <td style="text-align: center;">Controller model</td> <td style="text-align: center;">⇒</td> <td style="text-align: center;">Pump model</td> </tr> <tr> <td style="text-align: center;">ETC76</td> <td style="text-align: center;">⇒</td> <td style="text-align: center;">EBT70F-20</td> </tr> </table>	Controller model	⇒	Pump model	ETC76	⇒
Controller model	⇒	Pump model				
ETC76	⇒	EBT70F-20				

When requesting our company for repair or making other inquiries on the product, please do not forget to tell us the serial number.







 Warning	Earth
	Be sure to connect the earth line of the INPUT connector to EARTH/GROUND.

 Caution	Connections of cables
	Do not disconnect the cables or connectors of the controller in operation.

 Caution	Disassembly and modification
	Do not disassemble or modify the controller, the controller and the cable. It may result in failures or accidents and fails safety.

 Warning	Electric shock
	Do not touch the inside of the alive controller. Do not touch the inside of the controller within 5 minutes after turning the input power off, or you may get electric shock.

Document No. ME_CT_ETC76_(CN)_R0

 Warning	Ambient temperature and humidity
	Do not use the controller in an area of high temperature or high humidity
 Warning	Water drop
	Do not use the controller where water drips.
 Caution	Dust, flammable gas and corrosive gas
	Do not use the controller in an area exposed to dust, flammable gas or corrosive gas.
 Caution	Magnetic field and electric field
	Do not use the controller in a strong magnetic field or electric field.
 Caution	Radiation
	Do not use the controller in an area exposed to radiation.
 Caution	Vibration
	Do not use in the controller an area with a lot of vibration.
 Caution	Space
	Be sure to provide sufficient space around of open its top, side, and back.

Document No. ME_CT_ETC76_(CN)_R0

Warranty and Liability

EBARA guarantees the quality of its pumps, controllers, and their accessories as described in the included "Standard Warranty Certificate". Note, however, that handling the pump in manners not described in this manual will void all warranty. Use of the pumps and controllers under atypical conditions without prior consent from EBARA may also void the warranty.

Contents

	Page
1. Characteristics	6
2. Unpacking and carrying	6
2-1. Unpacking	
2-2. Carrying	
3. Installation	7
3-1. Dimensions	
3-2. Name of pump parts	
3-3. Warning label and name plate	
3-4. Mounting	
4. Cable connection	11
4-1. Power input connector connection	
4-2. Motor cable connection	
4-3. Fan cable connection	
4-4. Remote connector connection	
5. Operation	14
5-1. Pre-operation notes	
5-2. Power-on	
5-3. Local operation	
5-4. Remote operation	
6. Protection	16
7. Emergency stop	18
8. Scrapping	18
9. Specifications	19

Document No. ME_CT_ETC76_(CN)_R0

1. Characteristics

- 1) This controller is a high-frequency inverter to drive the pump. The controller controls motor current to a fixed value and set the output voltage proportional to output frequency. Thus the controller gives full play to its ability and can start the pump in a short time.
- 2) The pump and controller is conformed to regulations as follows.

EMC directive

[Emission]

EN61000-6-4:2001

EN55011:1998+A1:1999+A2:2002(Group1 Class A)

[Immunity]

EN61000-6-2:2005

EN61000-4-2:1995+A1:1998+A2:2001

EN61000-4-3:2002+A1:2002

EN61000-4-4:2004

EN61000-4-5:1995+A1:2001

EN61000-4-6:1996+A1:2001

EN61000-4-8:1993+A1:2001

EN61000-4-11:2004

2. Unpacking and carrying

2-1. Unpacking

Check the following items when unpacked.

A: Unpacking

Table 1 lists the controller weight.

Table 1 Controller weight

Controller model	Weight
ETC76	Max. 2.4 kg[6 lb]

B: Damage to the contents

Should any of the package contents be damaged or defective, contact EBARA prior to use.

Document No. ME_CT_ETC76_(CN)_R0

C: Accessories

The standard package includes following accessories. Should any item be missing, contact EBARA .

(1) REMOTE connector	1 set
(2) Power Input connector	1 set
(3) Instructions manual	1 copy

2-2. Carrying

When carrying the controller, or when mounting/dismounting the controller to/from the equipment, handle the controller with care.

	Caution	Avoid applying a shock onto the controller.
--	----------------	--

3. Installation

3-1. Dimensions

The external view and the dimensions of the controller are as illustrated below.

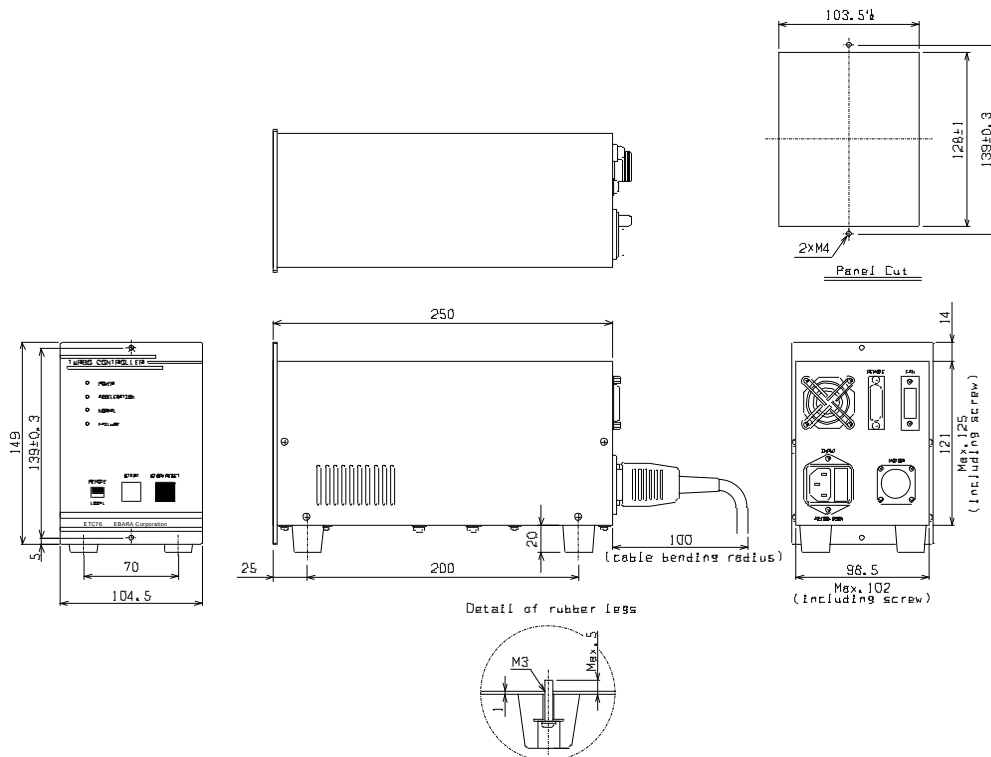

Figure 1 Controller external view and dimensions

	Caution	When fixing the controller with the hole of the rubber stand attachment, use M3 screws of 5mm or shorter.
--	----------------	---

Document No. ME_CT_ETC76_(CN)_R0

3-2. Name of pump parts

The controller parts are named as illustrated below.

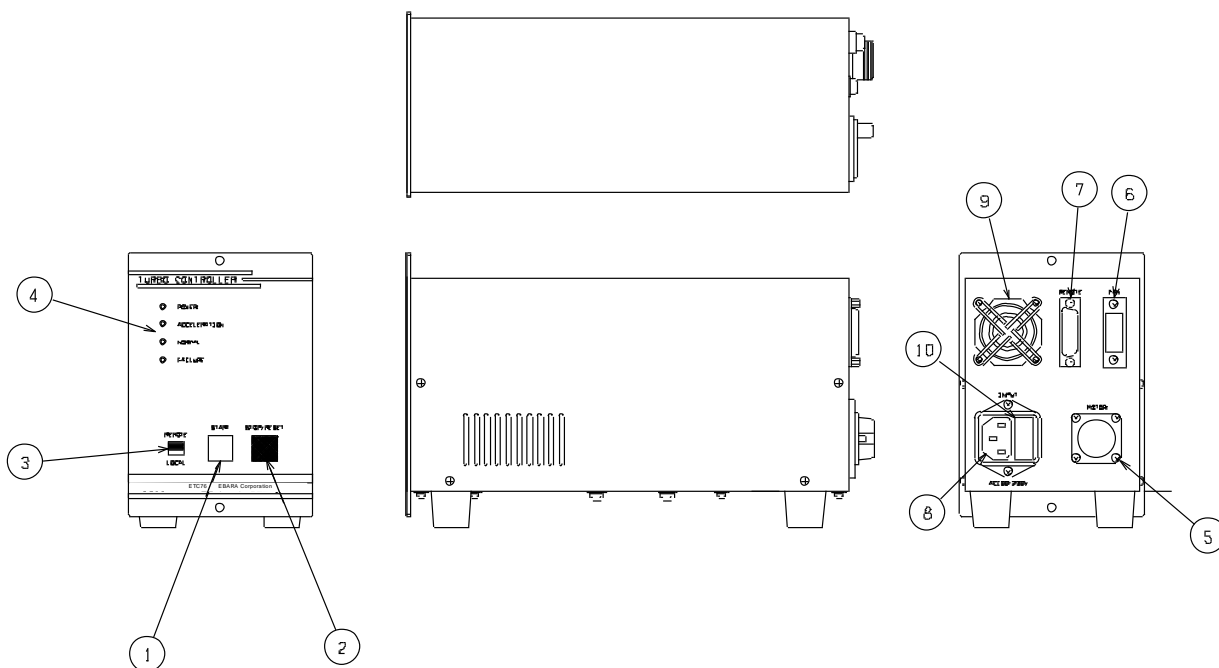

①	[START] switch	Starts the pump during local operation.
②	[STOP/RESET] switch	Stops the pump during local operation, and reset all protections during local operation.
③	[LOCAL/REMOTE] select switch	Selects between local operation and remote operation.
④	Status display LEDs	Indicates the operation status of the pump.
⑤	MOTOR connector	Connect the motor cable to this connector.
⑥	FAN connector	Connect the fan cable to this connector.
⑦	REMOTE connector	Connect the remote cable to this connector.
⑧	INPUT connector	Connect the power input cable to this connector.
⑨	FAN	When the controller is powered on, the fan will rotate to provide cooling.
⑩	FUSE (model: ET 3.15A / SOC x2)	When the overcurrent occurs, the circuit in the controller is protected. (When shipping, a spare fuse is not attached.)

Figure 2 Name of pump parts

Document No. ME_CT_ETC76_(CN)_R0

3-3. Warning label and name plate

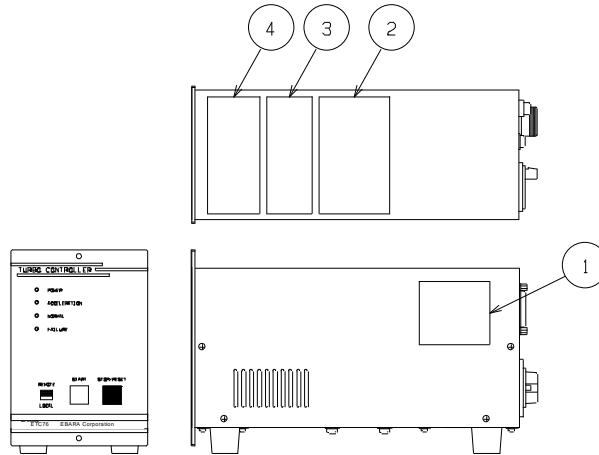

Number	Example	Content
① Main name plate	<p>TURBO CONTROLLER Model: ETC 76 Ser. NO.: *****-*** Date: \$\$-### Voltage: AC100-230V 1PH 50/60Hz SCCR: 35A Power: 160VA EBARA Corporation Made in Japan</p>	Indicates the controller's model name, serial number, date of manufacture, input voltage, SCCR, maximum power consumption.
② Warning label	<p>WARNING READ INSTRUCTION MANUAL CAREFULLY PRIOR TO OPERATION Failure to follow instruction may result in serious accidents, causing death, serious injury, and/or property damage.</p> <p>警告 運転前に必ず取扱説明書を読んで下さい。 取扱説明書にある手順に従わない操作が発生し、重大な事故が発生し、人が死亡または重傷を負ったり、物的損害を与える恐れがあります。</p>	READ INSTRUCTION MANUAL CAREFULLY PRIOR TO OPERATION Failure to follow instruction may result in serious accidents, causing death, serious injury, and/or property damage.
③ Warning label	<p>WARNING HAZARDOUS VOLTAGE INSIDE Can shock, burn or cause death. Turn power off before removing the cover.</p> <p>警告 危険電圧部有り 感電による火傷や死亡の恐れ有り。 電源を切ってからカバーを開けて下さい。</p>	HAZARDOUS VOLTAGE INSIDE Can shock, burn or cause death. Turn power off before removing the cover.
④ Warning label	<p>WARNING DOING SO MAY RESULT IN PUMP OR CONTROLLER FAILURE. Use the pump and controller in a correct combination.</p> <p>警告 ポンプとコントローラが故障する可能性があります。 ポンプとコントローラは正しい組み合わせで使用して下さい。</p>	DOING SO MAY RESULT IN PUMP OR CONTROLLER FAILURE. Use the pump and controller in a correct combination.

Figure 3 Warning label and name plate

Document No. ME_CT_ETC76_(CN)_R0

3-4. Mounting

The controller can be mounted in one of two ways.

- Mount to a rack.
- Mount directly to a wall.

When mounting the controller to a rack, refer to Figure 1 and Figure 4. Use the rubber stand attachment holes (4-M3 x 5) or other measures to provide support from the bottom.

Be sure to secure a space of 10 mm or greater to the top and sides of the controller, and 100 mm or greater to the rear.

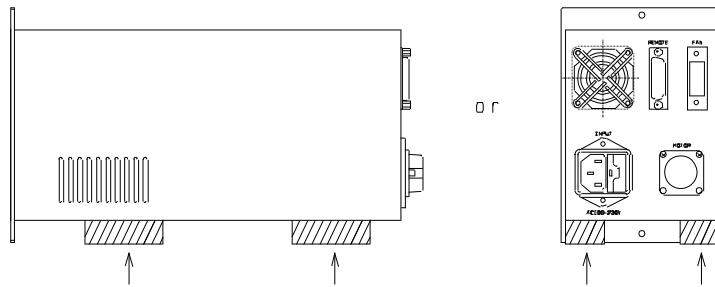





Figure 4 Controller fixture

 Caution	<p>Do not mount the controller solely by the attachment holes on its front panel. The controller is max. 2.4 kg[6 lb] in weight. If no support is provided from the bottom, the controller may fall, causing injury and/or controller damage.</p>
 Caution	<p>When installing the controller, secure the specified amount of open space around its top, sides, and back. Otherwise, the ventilation may become inadequate, increasing the internal temperature of the controller and causing a failure.</p>
 Caution	<p>When fixing the controller with the hole of the rubber stand attachment, use M3 screws of 5mm or shorter.</p>
 Warning	<p>Do not use the controller under the following environment.</p> <ul style="list-style-type: none"> • An area exposed to high temperature and/or humidity. • An area where water may drop. • An area exposed to explosive/flammable gas or dust. • An area exposed to corrosive and/or toxic gas. • An area exposed to a strong electromagnetic field. • An area with a lot of vibration. • An area exposed to radiation. <p>Use of the controller in an inappropriate location may result in death or serious injury, and/or controller damage or failure.</p>

Document No. ME_CT_ETC76_(CN)_R0

4. Cable connection

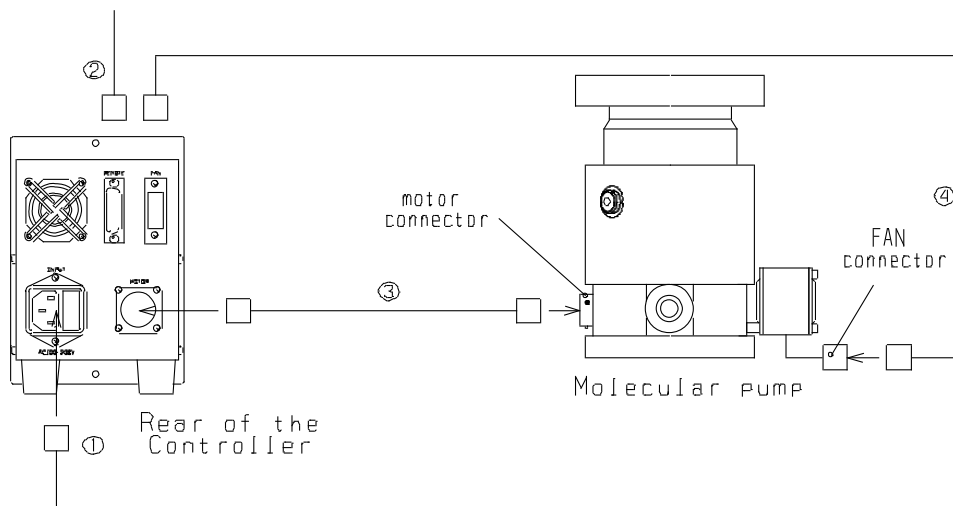

Figure 5 Cable connection for pump and controller

Table 2 Connectors and cables

No.	name	Connector type of the controller side	Connector type of the pump side	Remarks
①	Power Input Connector	YAMATE AP-400(B)		accessory
②	Remote Connector	OMRON XM2D-1501 XM2S-1511		accessory
③	Motor Cable	Nanaboshi NJC-207-PM-UL, CSA	Cable length:1-15m SOURIAU UTOW6128SNH-ADJ (S)M12SR438J-5 Cable length:16-20m Bendix PT06A-12-8S(SR)	Exclusive cable
④	Fan Cable*	AMP 1-178288-3	AMP 172233-1	Exclusive cable

* only to forced air cooling type pump

4-1. Power input connector connection

Connect the cable to the power input connector (accessory).

- 1) Select the input power cable show in the Table3.
- 2) Strip sheath of the cable about 30mm from the end.
- 3) Set the solderless terminals at the end of the cable, and cover the part of the cable which is clamped by a protective tube.

Document No. ME_CT_ETC76_(CN)_R0

4) After thread the cable through a bushing, screw the solderless terminals at each pin of the connector, and screw the cable clamp.

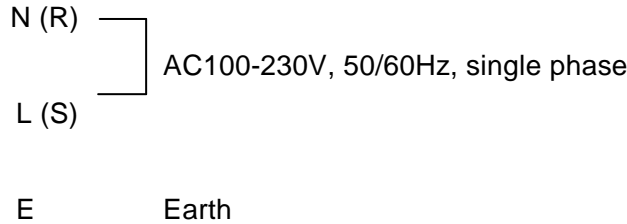



Table 3 Recommended specifications of input power cable

Cable	EN/IEC: IEC 60227 or IEC 60245 ANSI/UL/CSA: ANSI/UL 817 and CSA C22.2 No21 Outer diameter max.9mm / 0.75mm ² / 3cores
-------	--

 <p style="font-size: 1.2em; font-weight: bold;">Warning</p>	<p>Be sure to ground the power input cable.</p> <p>If not grounded, an electrical leakage may result in an electric shock and/or a fire.</p> <p>Implement a power breaker and an overcurrent protection device(*) for the controller’s input power circuit.</p> <p>The power breaker and the overcurrent protection device should have an ampere interruption capacity of 10,000A or greater.</p> <p>Failure to implement a power breaker and/or an overcurrent protection device may result in serious accidents, causing death, serious injury, and/or property damage.</p> <p>The connection to a main supply needs permanent connection such as connection to the industrial control panel. Do not use the plug to connect.</p> <p>If used the plug to connect to a main supply, the leakage current as provided by SEMI S2 standard ($\leq 3.5\text{mA}$) may not be satisfied.</p>
---	---

*: “Power breaker” refers to components that are used to cut off a power supply, such as circuit breakers, switches, and plugs that comply with the necessary standards.

“Overcurrent protection device” refers to components that are used to cut off short-circuit and ground-fault currents generated within the equipment, such as circuit breakers and fuses that comply with the necessary standards.

Some components, such as a circuit breaker with a protection device, offers both functionalities.

4-2. Motor cable connection

Using a designated cable, connect the motor connector on the pump to the motor connector on the back panel of the controller.

4-3. Fan cable connection

Using a designated cable, connect the fan connector on the pump to the fan connector on the back panel of the controller.

4-4. Remote connector connection

Connect the remote connector(accessory) to the remote connector on the back panel of the controller.

Refer to Remote I/O Signals and connect the provided remote connector correctly. These signals are all SELV (Safety Extra Low Voltage) circuits that are protected by double insulation or reinforced insulation from the hazardous voltage circuits. Table 4 lists recommended specifications of cable.

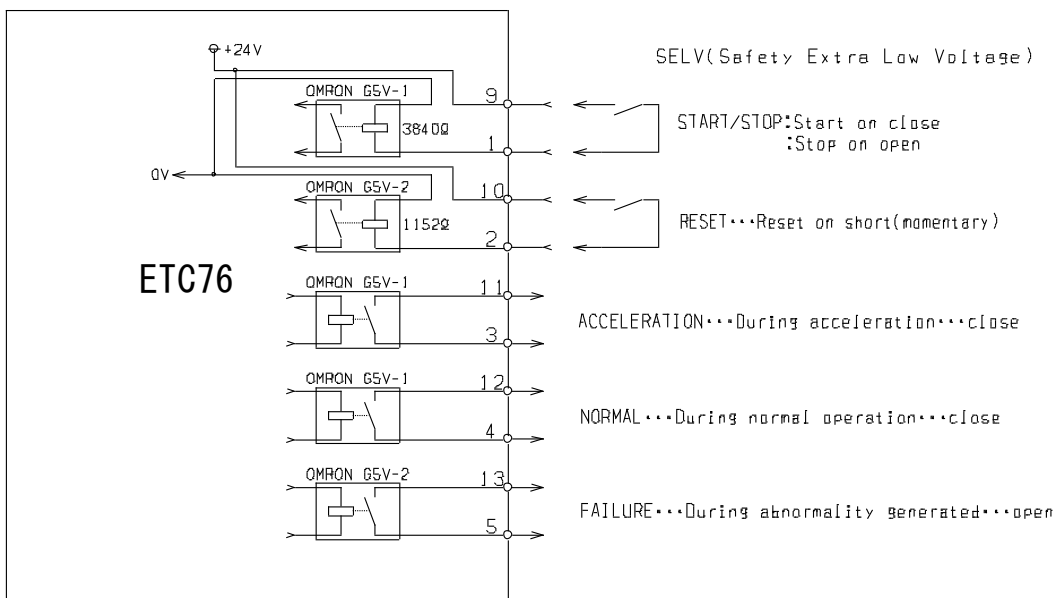





Figure 6 Remote I/O Signals

Table 4 Recommended specifications of remote cable

Cable	Shielded twisted-pair cable (Outer diameter max.10mm)
-------	--

Document No. ME_CT_ETC76_(CN)_R0

 Caution	Use these signals in only the SELV (Safety Extra Low Voltage, Generally it is less than AC25V or less than DC60V.) circuit that are protected by double insulation or reinforced insulation from the hazardous voltage circuits.
 Caution	Fix the connector with screws not to disconnect from the controller.
 Caution	RESET signal should not short-circuit in a usual state. The signal should be closed only when you reset protection function.
 Caution	Maximum capacity of output signal (Acc., Normal, Failure) is DC24V, 0.1A.

5. Operation

5.1 Pre-operation notes

Check the following before operating the controller.

- Combination of the pump and the controller

Controller model	⇒	Pump model
ETC76	⇒	EBT70F-20

- check that the connectors are connected properly.
- Check that the input power is 100-230V.
- For local operation or remote operation, set the [LOCAL/REMOTE] selection switch on the front panel properly. The factory setting is LOCAL.

5-2. Power-on

Supply the power to the controller.

Status	LED Display	Description
Power-off	<input type="radio"/> POWER <input type="radio"/> ACCELERATION <input type="radio"/> NORMAL <input type="radio"/> FAILURE	LED is all turned off.
Power-on	<input checked="" type="radio"/> POWER <input type="radio"/> ACCELERATION <input type="radio"/> NORMAL <input type="radio"/> FAILURE	The POWER LED is lit.

Document No. ME_CT_ETC76_(CN)_R0

5-3. Local Operation

5-3-1. Startup

To start the operation of the pump, press the [START] switch on the front panel of the controller.

Status	LED Display	Description
Accelerating	<ul style="list-style-type: none"> ● POWER ● ACCELERATION ○ NORMAL ○ FAILURE 	The ACCELERATION LED is lit, and the pump begins rotate.
Rated operation	<ul style="list-style-type: none"> ● POWER ○ ACCELERATION ● NORMAL ○ FAILURE 	When the actual rotation speed of the pump reaches 90 % of the specified rotation speed, the NORMAL LED is lit.

5-3-2. Stop

To stop the operation of the pump, press the [STOP] switch on the front panel of the controller.

Status	LED Display	Description
Decelerating ↓ Stop	<ul style="list-style-type: none"> ● POWER ○ ACCELERATION ○ NORMAL ○ FAILURE 	The NORMAL LED turns off, and pump begins shutting down by free-running (without brake).

5.4 Remote Operation

Shorten the pin No. 1 and 9 of the connector, and the pump begins starting up. Open the pins, and the pump begins shutting down by free-running (without brake).

Following signals are provided from the remote connector. Apply the signals what you want.

- 1) Acc. signal (Pin No. 3,11)

Closed when the rotational speed is 0-90 % of rated speed in starting up.

- 2) Normal signal (Pin No. 4,12)

Closed when the rotational speed is 90-100 % of rated speed.

- 3) Failure signal (Pin No. 5,13)

Open when the protection of the controller works.

Document No. ME_CT_ETC76_(CN)_R0

6. Protection

If the controller or the pump has something wrong, FAILURE LED turns red, and the pump begins shutting down by free-running (without brake).

In such a case, failure signal on pin No. 5 and 13 of the connector becomes open.

Table 5, 6 and 7 list items of failure, causes and measures. Guess the cause, and remove it.

Table 5 Failure which can reset

Failure mode	Possible cause	Measure
Delay in acceleration Unable to reach the rated speed within 6 minutes from start.	1) The backing pressure is too high. 2) Leakage in the system. 3) Too much of gas flow rate.	1) Keep the backing pressure 1200Pa or lower. 2) Check if the system has any leakage. 3) Stop the gas flow during starting up.
Motor step out Unable to control the motor because of too much load.	1) Foreign matter is in the pump. 2) The backing pressure is too high.	1) Send back the pump when it has foreign matter inside. 2) Keep the backing pressure 1200Pa or lower.
Controller Overheat The temperature inside the controller is 80°C [176°F] or higher.	1) Ambient temperature is too high.	1) Keep the ambient temperature 45°C [113°F] or lower.

When you reset the controller, shorten the pin No. 2 and 10 of the connector. Keep shortening the pins for 5msec or longer. Remove the cause of failure before resetting. Note that the pump begins to start up as soon as you reset, if the Start/Stop signal is closed and you reset.

Keep the Reset signal open usually.



Table 6 Failure automatically reset

Failure mode	Possible cause	Measure
Motor overheat The motor temperature in the pump is 105°C [221°F] or higher.	1) Ambient temperature is too high. 2) The backing pressure is too high. 3) Too much of gas flow rate. 4) Leakage in the system.	1) Keep the ambient temperature 38°C [100°F] or lower. 2) Cool the pump and keep the surface temperature 50°C [122°F] or lower. 3) Keep the backing pressure 1200Pa or lower. 4) Keep the gas flow rate under the allowable rate. 5) Check if the system has any leakage.
Input power voltage loss, drop off Input power voltage has kept 90V or lower for 80 msec.	1) Input power voltage is lost or dropped off.	1) Check the input power voltage

These failure are automatically reset if motor temperature or input power voltage return to a normal value. For remote operation, note that the pump begins to start up as soon as automatically reset, if the Start/Stop signal is closed.

Table 7 Failure which cannot reset

Failure mode	Possible cause	Measure
Output over-current Motor current has exceeded a specified value.	Short-circuit on motor, etc.	Put off the input power, wait for several minutes, and put in the input power again. Send the pump back to EBARA or our service centers.(*).
System error Fatal error inside the controller	Breakdown of controller	
Over speed Rotational speed has exceeded 105% of the rated speed.	Breakdown of controller	

You cannot reset the controller with the Reset signal if it has any failure listed in table 7. Put off the input power, wait for several minutes, and put in the input power again. If the failure keeps even after retrying, the controller has something wrong. Send the pump back to EBARA .

*: For our contact information, refer to the end of this manual.



7. Emergency stop

Pull out power input cable in an emergency. After power supply interruption, pump begins shutting down by free-running. The pump will come to a complete stop in about 25 minutes.

8. Scrapping

Scrap the controller as an industrial waste, in accordance with national and regional regulations.



9. Specifications

Controller model		ETC76
Environment	Allowable temperature	0 – 45 °C [32 – 113°F]
	Allowable humidity	5 – 85 %
Input	Voltage	AC100 – 230 V
	Phase	Single
	Frequency	50/60 Hz
	Max. power	160 VA
	Rated power	60 VA
	Over voltage category	II
Output	Phase	3
	Rated current	2.9 Arms
	Rated frequency	1500 Hz
Weight		max. 2.4 kg [6 lb]
IP code		IP20 (service area, operation area)