

Quick Start Guide and Health and Safety Information

Turbo Instrument Controller (TIC)



Description	Item Number
TIC Instrument Controller 3 Gauge	D397-00-000
TIC Instrument Controller 6 Gauge	D397-01-000
TIC Instrument Controller 6 Gauge Capacitance Manometer	D397-02-000
TIC Turbo Controller 100 W	D397-11-000
TIC Turbo Controller 200 W	D397-12-000
TIC Turbo & Instrument Controller 100 W	D397-21-000
TIC Turbo & Instrument Controller 200 W	D397-22-000

Chemtech Scientific provides access to this content as a courtesy.
We do not own the content contained in this document.
All rights and credit go directly to its rightful owners.
www.chemtechsci.com
Call us at: 484-424-9415



Material Declaration

In accordance with the requirements of the Chinese regulatory requirement on the Management Methods for the Restriction of the Use of Hazardous Substances in Electrical and Electronic Products Order No. 32 (also known as 'China RoHS2') and SJ/T 11364 Marking for the Restricted Use of Hazardous Substances in Electronic and Electrical Products:

Product	Product Label	Meaning
D39700000 TIC Instrument Controller D39701000 TIC Instrument Controller 6 Gauge D39702000 TIC Instrument Controller 6 Gauge Capacitance Manometer D39711000 TIC Turbo Controller 100 W D39712000 TIC Turbo Controller 200 W D39721000 TIC Turbo and Instrument Controller 100 W D39722000 TIC Turbo and Instrument Controller 200 W		This product contains hazardous substances in at least one of the homogeneous materials used which are above the limit requirement in GB/T 26572 as detailed in the declaration table below. These parts can safely be used for the environmental protection use period as indicated.

材料成分声明 Materials Content Declaration

部件名称 Part name	有害物质 Hazardous Substances					
	铅 Lead (Pb)	汞 Mercury (Hg)	镉 Cadmium (Cd)	六价铬 Hexavalent Chromium (Cr VI)	多溴联苯 Polybrominated biphenyls (PBB)	多溴二苯醚 Polybrominated diphenyl ethers (PBDE)
印刷电路组件 (PCA) Printed Circuit Assembly (PCA)	X	O	X	O	O	O
电缆/电线/连接器 Cable/wire/connector	X	O	O	O	O	O
机械部件 Mechanical Components	X	O	O	O	O	O

O: 表示该有害物质在该部件的所有均质材料中的含量低于 GB/T 26572 标准规定的限量要求。
 O: Indicates that the hazardous substance contained in all of the homogeneous materials for this part is below the limit requirement in GB/T 26572.
 X: 表示该有害物质在该部件的至少一种均质材料中的含量超出 GB/T26572 标准规定的限量要求。
 X: Indicates that the hazardous substance contained in at least one of the homogeneous materials used for this part is above the limit requirement of GB/T26572.

NOTE: These products are EU RoHS compliant, the following Exemptions apply:

- 6(b) **Lead** as an alloying element in aluminium containing up to 0.4% by weight
- 6(c) Copper alloy containing up to 4% **lead** by weight
- 7(a) **Lead** in in high melting temperature type solder (i.e. lead based alloys containing 85% by or more)
- 7(b) **Lead** in solders for servers, storage and storage array systems, network infrastructure equipment for switching, signalling, transmission, and network management for telecommunications
- 7(c) I Electrical and electronic components containing **lead** in a glass or ceramic other than dielectric ceramic in capacitors, e.g. piezoelectronic devices, or in a glass or ceramic matrix compound
- 7(c) II **Lead** in dielectric ceramic in capacitors for a rated voltage of 125 V AC or 250 V DC or higher
- 8(b) **Cadmium** and its compounds in electrical contacts
- 15 **Lead** in solders to complete a viable electrical connection between semiconductor die and carrier within integrated circuit flip chip packages
- 34 **Lead** in cermet-based trimmer potentiometer elements

Contents

Section	Page
1 Introduction	1
1.1 Scope and definitions	1
1.2 Product description	1
2 Technical data	3
2.1 Electrical data	3
2.2 Operating and storage data	3
3 Installation	5
3.1 Unpack and inspect	5
3.2 Fitting the controller	5
3.3 Controller electrical connections	8
3.3.1 Connecting the electrical supply	9
3.3.2 Additional earth bonding	9
4 Operation	11
4.1 Menu structure	12
5 Maintenance and service	15
5.1 Safety	15
5.2 Fault finding	15
5.3 Cleaning the controller	15
5.4 Software updates	15
6 Storage and disposal	17
6.1 Storage	17
6.2 Disposal	17
7 Service	19
Index	21

For return of equipment, complete the HS Forms at the end of this manual.

Illustrations

Figure	Page
1 Dimensions of a bench mounted TIC (mm)	6
2 Front panel removal	7
3 Rack mounting of a TIC	7
4 Rear panel connections	8
5 Front panel display	11
6 View screen shortcuts	12
7 Menu structure	13

Tables

Table	Page
1 Checklist of components	6
2 Front panel symbols and their functions	11

1 Introduction

1.1 Scope and definitions

This manual provides basic Installation, Operation and Maintenance instructions for the Edwards Turbo Instrument Controller (TIC). You must use the Controller as specified in this manual.

Read this manual before you install and operate the Edwards Turbo Instrument Controller. Important safety information is highlighted as WARNING and CAUTION instructions; you must obey these instructions. The use of WARNINGS and CAUTIONS is defined below.

Note: The detailed instruction manuals are held on the CD provided.

Note: If the interlocks are not used the logic interface adaptor must be fitted to the 25-way connector.



WARNING

Warnings are given where failure to observe the instruction could result in injury or death to people.

CAUTION

Cautions are given where failure to observe the instruction could result in damage to the equipment, associated equipment and process.

Throughout this manual, page, figure or table numbers are sequential.

The following labels appear on the controller:



Warning - refer to accompanying documentation.



Edwards offer European customers a recycling service.

1.2 Product description

There are seven variants of the TIC, each of which is provided with a large clear graphics display, easy-to-use control interface via a keypad, an RS232/485 interface for control and data monitoring on a remote PC and a logic interface for interlocking with associated system hardware.

Note: The detailed instruction manuals are held on the CD provided.

This page has been intentionally left blank.

2 Technical data

2.1 Electrical data

Connector type	CEE/IEC 320
Electrical supply	90 to 264 V a.c. 47 to 63 Hz
Power consumption	Instrument TIC: 55 VA max (D397-00-000) 6 Gauge Instrument TIC: 160 VA max (D397-01-000, (D397-02-000) 100 W Turbo and Turbo instrument TIC: 215 VA max (D397-11-000, D397-21-000) 200 W Turbo and Turbo instrument TIC: 350 VA max (D397-12-000, D397-22-000)
Fuse	The unit is self-protecting and has no user replaceable fuse. The unit will recover once any overload is removed.
Earth Stud	M4
Weight	
TIC Instrument Controller 3 Gauge	1.3 kg
TIC Instrument Controller 6 Gauge	1.7 kg
TIC Turbo Controller 100 W	1.7 kg
TIC Turbo Controller 200 W	1.8 kg
TIC Turbo and Instrument Controller 100 W	1.8 kg
TIC Turbo and Instrument Controller 200 W	1.9 kg

2.2 Operating and storage data

Ambient operating temperature range	0 °C to 40 °C
Ambient storage temperature range	-30 °C to 70 °C
Maximum ambient operating humidity	Max 90% RH non condensing at 40 °C
Maximum operating altitude	3000 m max
IP rating	20

This page has been intentionally left blank.

3 Installation

3.1 Unpack and inspect

Remove all of the packaging material and check the Controller. If the Controller is damaged, follow the Edwards return of equipment procedures that are laid out in the back of this manual. Do not use the Controller if it is damaged.

Check that your package contains the items that are listed in [Table 1](#). If any of these items are missing, notify your supplier in writing within three days. If the Controller is not to be used immediately, store the Controller in suitable conditions as described in [Section 6.1](#).

3.2 Fitting the controller



WARNING

If access to the IEC connector is restricted an additional isolation device should be provided, which will be easily accessible by an operator.



WARNING

Ensure that all electrical wiring is safely secured so that people cannot trip on them.

CAUTION

Rubber feet must be fitted ([Figure 1](#), item 1) so that there are correct clearances for air circulation. If you do not, the performance of the Controller may be affected at high operating temperatures.

CAUTION

The unit should be supported at the rear when rack, cabinet or panel mounted.

CAUTION

Allow 150 mm at the rear for cables. Allow 50 mm top and bottom and 15 mm to the sides for sufficient air circulation. Do not cover any of the ventilation holes.

CAUTION

This unit is IP20 rated. Please ensure that the unit is not installed where fluids can enter into the controller.

The Controller can be used on a bench-top or can be fitted in a rack, cabinet or panel. [Figure 1](#) shows the dimensions of the TIC that are required for bench top use. Panel cut information is provided in the main manual on the CD.

Note: If the interlocks are not used the logic interface adaptor must be fitted to the 25-way connector.

Table 1 - Checklist of components

Quantity	Description	Check (✓)
1	Controller	<input type="checkbox"/>
1	Quick Guide and Health and Safety Information	<input type="checkbox"/>
1	CD with PC program and main instruction manual	<input type="checkbox"/>
2	Rear non-slip feet	<input type="checkbox"/>
1	Logic interface plug	<input type="checkbox"/>
1 per 3 gauge channel	Analogue output mating half Instrument Controller only	<input type="checkbox"/>

Figure 1 - Dimensions of a bench mounted TIC (mm)

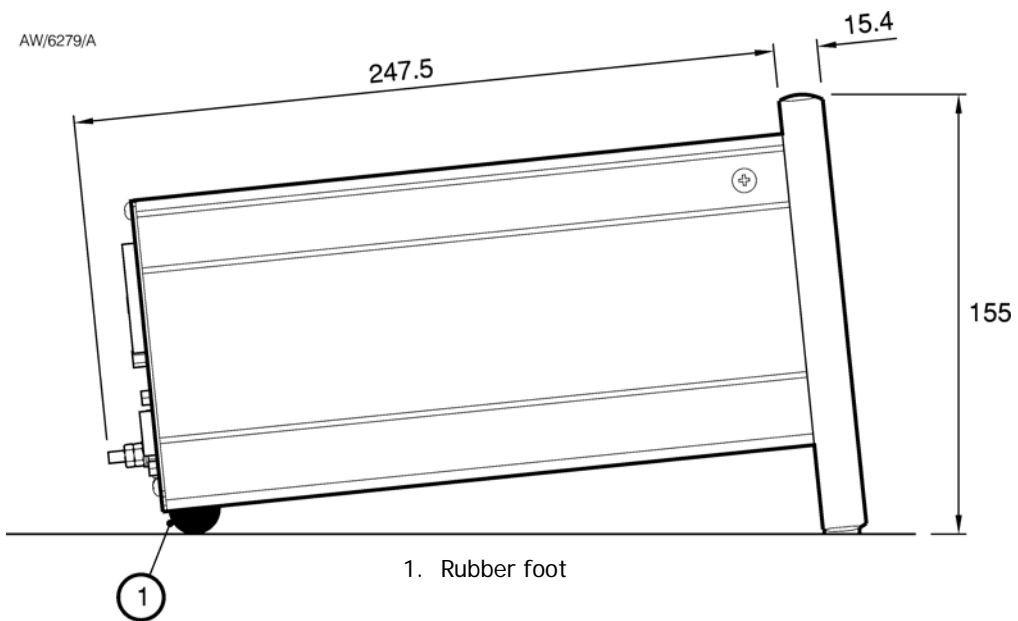

If a Controller is fitted in a rack or cabinet, follow the directions given in [Figure 2](#) and [3](#).

Figure 2 - Front panel removal

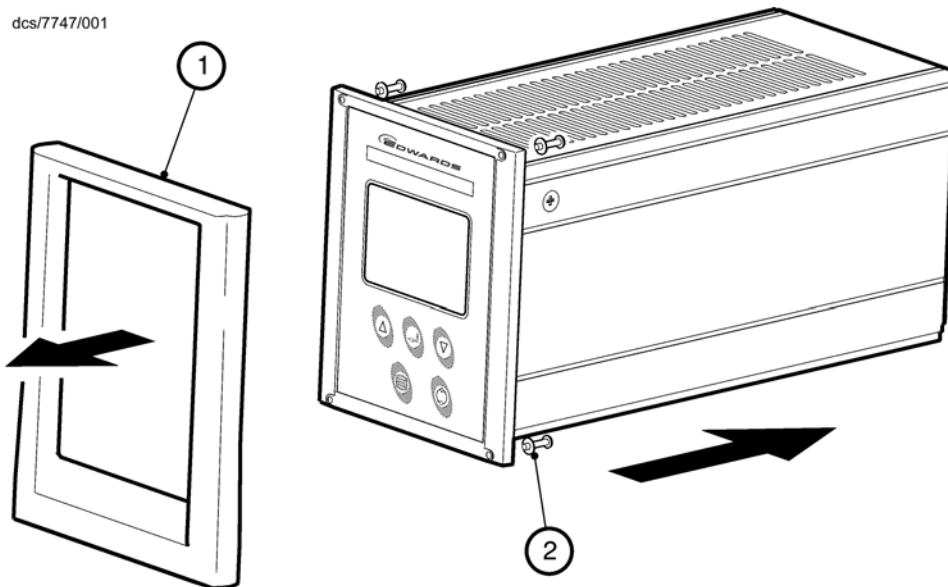

1. Bench top adaptor
2. Fixing screw and washer

- Remove the bench top adaptor (Figure 2, item 1) by removing the four screws (Figure 2, item 2).
- Slide the controller into the 19" rack. The use of 19" rack guide rails (Figure 3, item 2) is recommended.
- Fix the controller in place using four screws removed previously (Figure 3, item 1).

Figure 3 - Rack mounting of a TIC

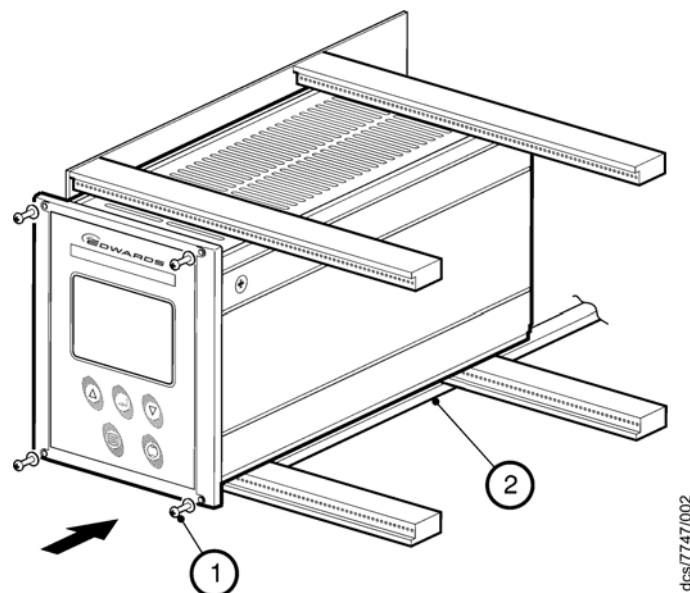

1. Fixing screw and washer
2. 19" rack guide rails

3.3 Controller electrical connections

CAUTION

Connecting Barocel capacitance manometers to any version of TIC without 6 gauge inputs will result in damage to the gauge and will invalidate the warranty. All versions of 6 Head instrument controllers are 'cap man safe' but only the controller that includes the cap man power supply will be able to read them. To ensure cap man protection a minimum time of 1 second is required between disconnecting an alternative gauge type from that port and connecting the cap man gauge.

Figure 4 - Rear panel connections

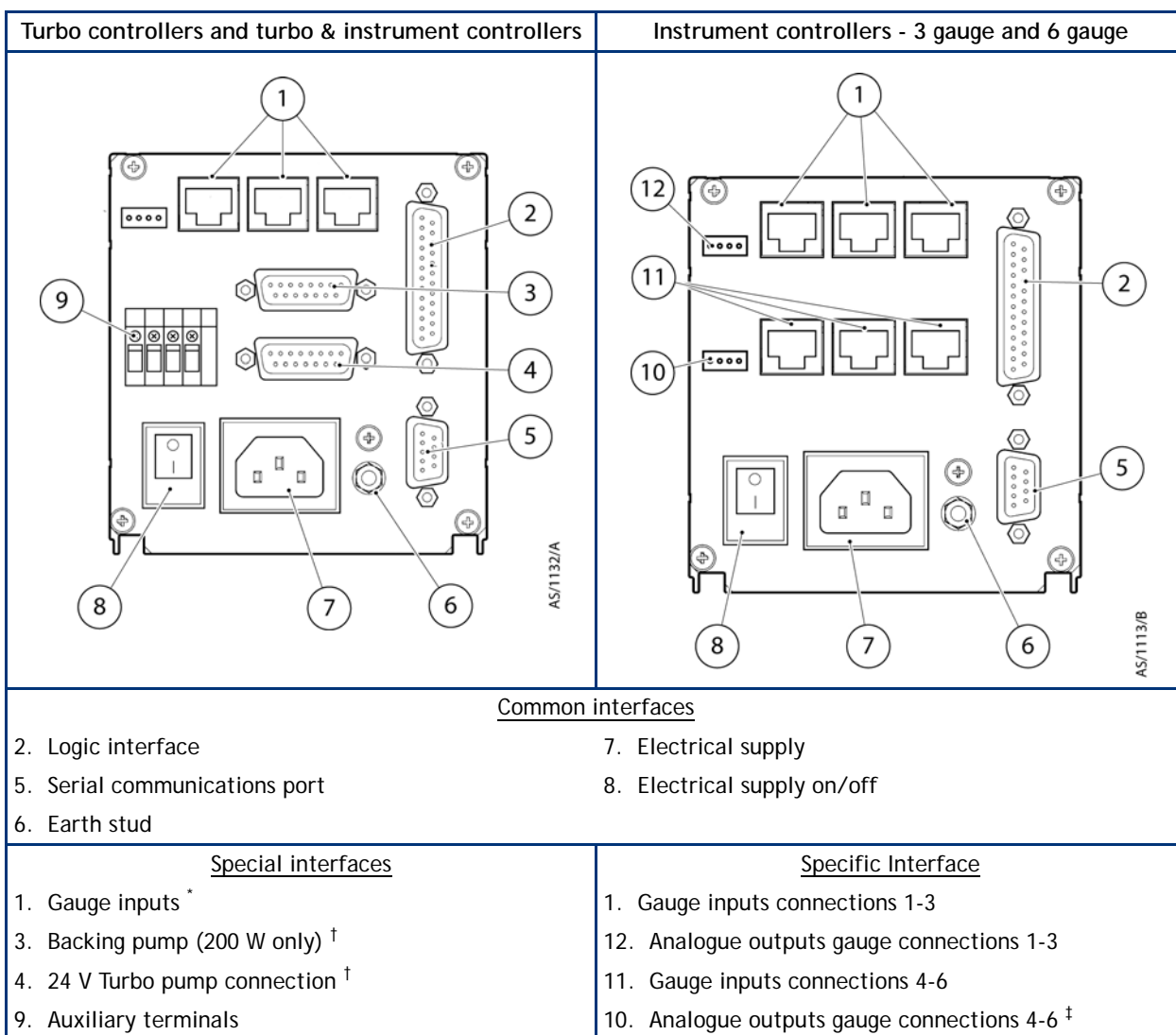

^{*} TIC Turbo and instrument controllers only

[†] TIC Turbo controllers and TIC Turbo and instrument controllers only

[‡] TIC Instrument controller 6 gauge

3.3.1 Connecting the electrical supply



WARNING

High voltages exist in the Controller when it is operating. Ensure that the Controller is earthed and observe all appropriate safety precautions for the safe installation and handling of electrical equipment. If you do not, there will be a danger of injury or death to people by electric shock.

Ensure that the electrical supply switch is set to 'off' and then connect the TIC to the electrical supply with an appropriate supply cable.

3.3.2 Additional earth bonding

The electrical supply cable normally provides protective earthing for electrical safety. If this is not the case, or if additional earth bonding is required, then the earth stud on the rear of the Controller (Figure 4, item 6) should be connected to your vacuum system earth.

The earth connection of any vent valves or air coolers should also be connected to this earth stud to ensure that they are adequately earthed.

Connect a suitably earthed cable between the two nuts fitted to the earth stud on the rear of the TIC.

Note: Do not remove the bottom nut from the earth stud.

This page has been intentionally left blank.

4 Operation

Figure 5 - Front panel display

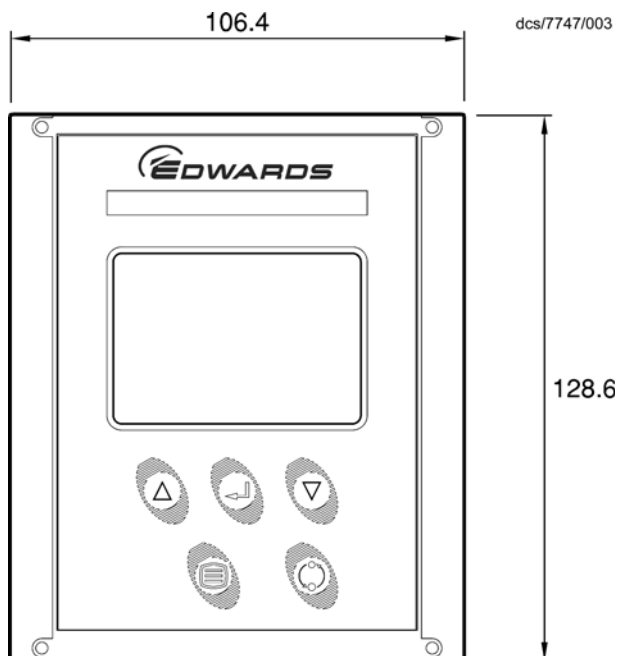







Table 2 - Front panel symbols and their functions

Symbol	Name	Function
	UP	Move up through a menu. Cycle selected numerical values up. Cycle a selected list item upwards.
	DOWN	Move down through a menu. Cycle selected numerical values down. Cycle a selected list item downwards.
	SELECT	Enter the highlighted sub-menu. Edit the highlighted list or numerical item. Move to the next digit of a numerical value. Jump to the setup screen for the highlighted gauge or pump.
	MENU	Switch between the default view screen and the main menu. Exit the current sub-menu or setup screen. Abort edit of a selected list item. Move to the previous digit of a numerical value.
	CYCLE	Turn a highlighted gauge or pump on or off.

4.1 Menu structure

Figure 6 and 7 show the view screen shortcuts and menu structure for the TIC. They also give an indication as to what buttons will take you where within the menu layout.

Note: Certain products have different functionality. The detailed instruction manuals are held on the CD provided.

Figure 6 - View screen shortcuts

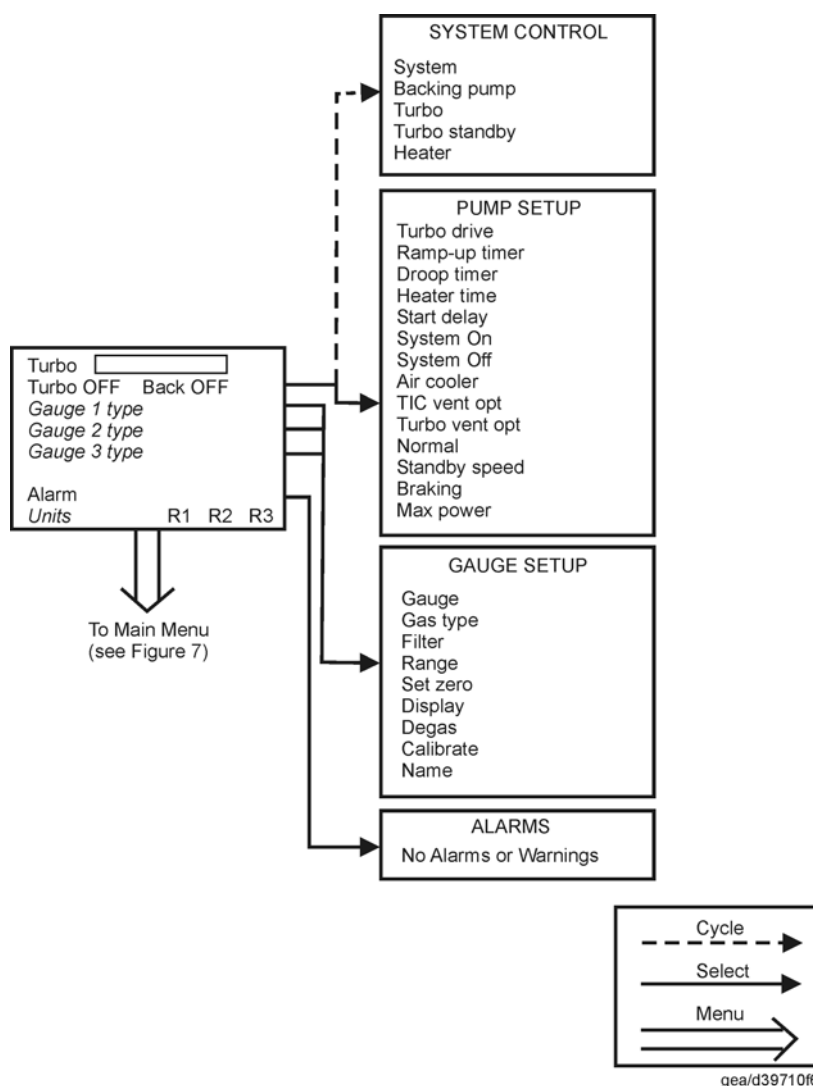
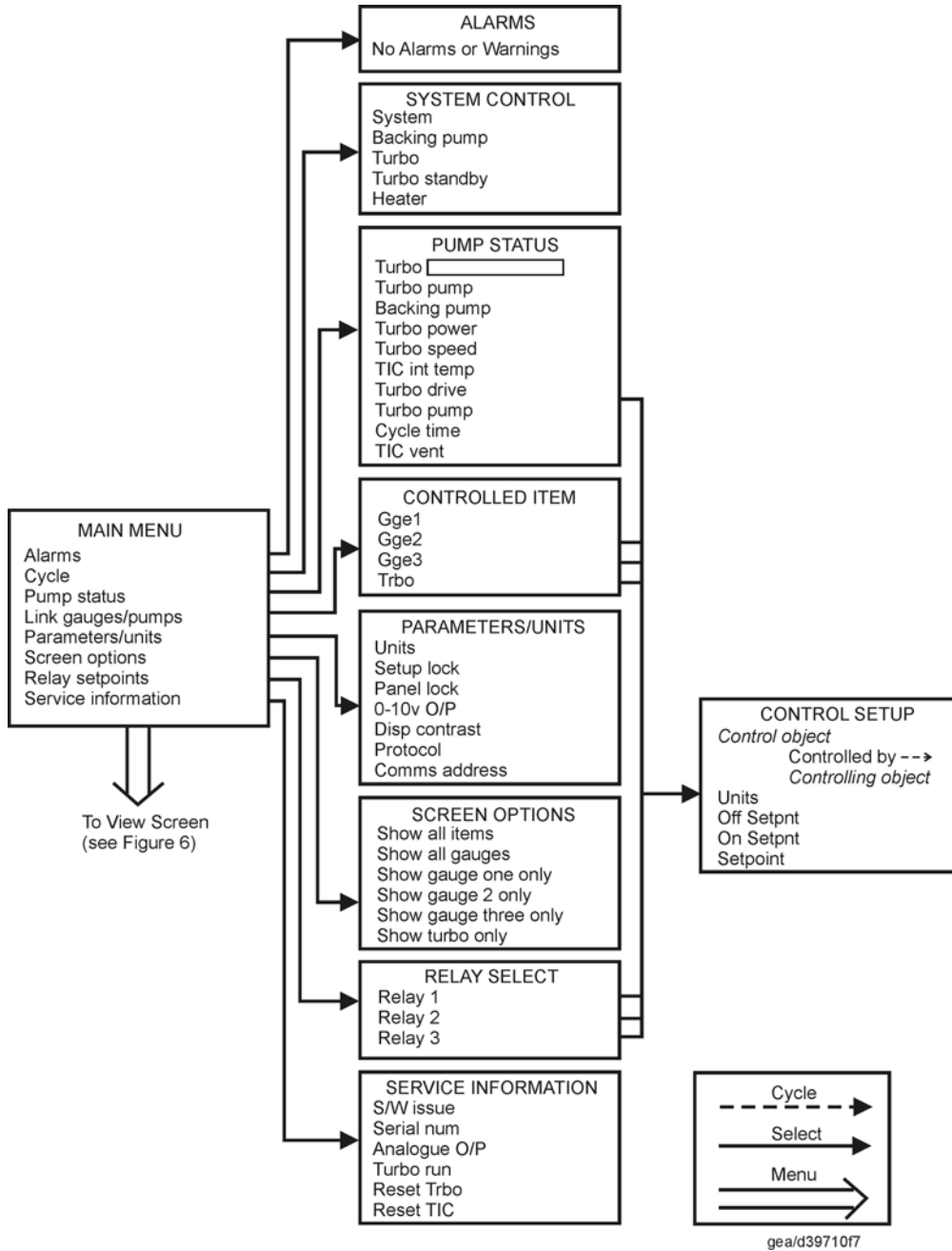

Figure 7 - Menu structure



This page has been intentionally left blank.

5 Maintenance and service

5.1 Safety



WARNING

Obey the safety instructions given below and take note of the appropriate precautions. If you do not, you could cause injury to people or damage to equipment.

There are no serviceable parts on the TIC. Do not open, return to your nearest Edwards Service Centre for any repairs that are necessary.

The Edwards return of equipment forms can be found at the rear of this manual.

5.2 Fault finding

Refer to the appropriate sections of the main manual on the CD.

5.3 Cleaning the controller

If necessary, use a soft dry cloth to clean the exterior of the Controller. Do not clean with harsh abrasives or liquids.

If the interior of the Controller requires cleaning, it is our recommendation that you return the Controller to your supplier or your nearest Edwards Service Centre.

5.4 Software updates

The software within the Controller and the TIC PC monitor program will be updated as part of Edwards ongoing development program. The updates and associated instruction manual can be found by visiting www.upgrades.edwardsvacuum.com.

This page has been intentionally left blank.

6 Storage and disposal

6.1 Storage

Store the Controller in clean dry conditions in accordance with the technical specifications. (Refer to [Section 2](#)).

6.2 Disposal



WARNING

Do not incinerate the Controller. If the Controller is heated to very high temperatures, dangerous gases may be emitted and internal components may explode.

Dispose of the Controller and any components safely in accordance with all-local and national safety and environmental requirements.

Alternatively, you may be able to recycle the Controller and/or cables; contact Edwards or your supplier for advice (also see below).

The Controller and associated cables are within the scope of the European Directive on Waste Electrical and Electronic Equipment, 2002/96/EC. Edwards offers European customers a recycling service for the Controller/cables at the end of the product's life. Contact Edwards for advice on how to return the Controller/cables for recycling.

This page has been intentionally left blank.

7 Service

A worldwide network of Edwards Service Centres supports Edward's products. Each Service Centre offers a wide range of options including equipment decontamination; service exchange; repair; rebuild and testing to factory specifications. Equipment, which has been serviced, repaired or rebuilt, is returned with a full warranty.

For more information about service options, contact your nearest Service Centre or other Edwards company.

This page has been intentionally left blank.

Index

A

Additional earth bonding9

C

Cleaning the controller 15

Connecting the electrical supply9

D

Disposal 17

E

Electrical data3

F

Fault finding 15

Fitting the controller5

I

Installation5

M

Maintenance and service 15

Menu structure 12

O

Operating and storage data3

Operation 11

P

Product description1

S

Safety 15

Scope and definitions1

Service 19

Software updates 15

Storage 17

Storage and disposal 17

T

Technical data3

U

Unpack and inspect5

W

Weight3

This page has been intentionally left blank.