

Instruction Manual

D-LAB Laboratory Vacuum Pumps



Description	Item Number
D-LAB 10-100, diaphragm pump, 110 V, 60 Hz, single-phase	A480-15-941
D-LAB 10-100, diaphragm pump, 220-240 V, 50 Hz, single-phase	A480-15-960
D-LAB 10-100, diaphragm pump, 100 V, 50/60 Hz, single-phase	A480-15-933
D-LAB 20-100, diaphragm pump, 110 V, 60 Hz, single-phase	A480-17-941
D-LAB 20-100, diaphragm pump, 220-240 V, 50 Hz, single-phase	A480-17-960
D-LAB 10-100, diaphragm pump, 100 V, 50/60 Hz, single-phase	A480-17-933
D-LAB 34-100, diaphragm pump, 110 V, 60 Hz, single-phase	A480-21-941
D-LAB 34-100, diaphragm pump, 220-240 V, 50 Hz, single-phase	A480-21-960
D-LAB 10-100, diaphragm pump, 100 V, 50/60 Hz, single-phase	A480-21-933
D-LAB 10-8, diaphragm pump, 110 V, 60 Hz, single-phase	A480-16-941
D-LAB 10-8, diaphragm pump, 220-240 V, 50 Hz, single-phase	A480-16-960
D-LAB 10-100, diaphragm pump, 100 V, 50/60 Hz, single-phase	A480-16-933
D-LAB 20-8, diaphragm pump, 110 V, 60 Hz, single-phase	A480-18-941
D-LAB 20-8, diaphragm pump, 220-240 V, 50 Hz, single-phase	A480-18-960
D-LAB 10-100, diaphragm pump, 100 V, 50/60 Hz, single-phase	A480-18-933
D-LAB 34-8, diaphragm pump, 110 V, 60 Hz, single-phase	A480-22-941
D-LAB 34-8, diaphragm pump, 220-240 V, 50 Hz, single-phase	A480-22-960
D-LAB 10-100, diaphragm pump, 100 V, 50/60 Hz, single-phase	A480-22-933

110 V versions are supplied with USA plug

220-240 V versions are supplied with IEC plug

100 V versions are supplied with a Japanese plug

Contents

1. Introduction	3
1.1 Modular System	3
1.1.1 Vacuum Pump with two Separators (System SR)	3
1.1.2 Vacuum Pump with Separator and High Performance Condenser (System SH)	4
1.1.3 Vacuum Pump with Separator, High Performance Condenser and one Vacuum Controller (System SC)	4
1.1.4 Vacuum Pump with Separator, High Performance Condenser and two Vacuum Controllers (system SCC)	4
2. General Safety Precautions	4
3. Assembling or Upgrading your System	5
3.1 Mounting the pump to the Baseplate	5
3.2 Assembling a System with Baseplate and two Separators	5
3.3 Assembling a System with Baseplate, Separator and High Performance Condenser	5
3.4 Assembling a System with Baseplate, Separator, High Performance Condenser, Electrical Supply Unit and one Vacuum Controller	6
3.5 Assembling a System with Baseplate, Separator, High Performance Condenser, Electrical Supply Unit and two Vacuum Controllers	7
3.5.1 Existing system with Baseplate, Separator, Condenser	7
3.5.2 Existing System with Electrical Supply Unit, Support Bar and One Vacuum Controller	8
3.6 Mounting of Gas Ballast (option for two headed pumps)	8
4. Operating Instructions	8
4.1 General Notes	8
4.2 Operating conditions	9
4.3 Operation of the Pump System	9
4.3.1 Operation with Baseplate and two Separators	9
4.3.2 Operation with Baseplate, Separator and High Performance Condenser	9
4.3.3 Operation with Baseplate, Separator, High Performance Condenser, Electrical Supply Unit and one Vacuum Controller	9
4.3.3.1 Setting the vacuum level	10
4.3.3.2 Setting the Pressure Differential	10
4.3.3.3 Automatic Adjustment of Pre-Set Vacuum Level	10
4.3.3.4 Starting the System Pumping	10
4.3.3.5 Interrupting Pumping	10
4.3.3.6 Restarting after interrupting pumping cycle	10
4.3.3.7 Continuous Pumping to Ultimate Vacuum/Drying Mode	10
4.3.3.8 Venting the System	11
4.3.3.9 Setting of the Ventilation Limits	11
4.3.4 Operation with Baseplate, Separator, High Performance Condenser, Electrical Supply Unit and Two Vacuum Controllers	11
4.3.5 Gas Ballast Option	11
5. System Shutdown	11
6. Troubleshooting	11
6.1 System without vacuum controller	11
6.2 System with one Controller	12
6.3 System with two Controllers	12
7. Changing the Diaphragms and the Valve Plates	12
7.1 Single Head Pumps	12
7.2 Twin Head Pumps	13
8. Ordering Information	13
8.1 D-LAB Vacuum Pumps	13
8.2 Replacement Parts	13
8.3 Accessories for the modular D-LAB-System	13
9. Specifications	15
10. Performance Graphs	16

Introduction

The D-LAB vacuum pump series was developed specifically to satisfy the exacting standards, reliability and ease of use demanded in today's laboratory applications.

Diaphragm pump technology has proved itself during recent decades and the D-LAB range is a logical continuation of this technology.

With six different pumping capacities and having facilities for modular expansion, a D-LAB pumping system can be optimised for any application.

Example of uses:

- ★ Vacuum filtration
- ★ Vacuum distillation
- ★ Vacuum drying
- ★ Impregnation
- ★ Rotary evaporation
- ★ Pumping and transferring of gases
- ★ Gel drying

Item Description

- | | |
|-----|---|
| 1. | Vacuum Pump |
| 2. | On/off switch of pump |
| 3. | Electrical Supply Unit |
| 4. | Baseplate |
| 5. | Locating pin for pump |
| 6. | Support Bar for Condenser |
| 7. | Support Bar for Vacuum Controller Separator |
| 8. | Separator |
| 9. | Holder for Separator |
| 10. | Hose connector |
| 11. | High performance Condenser |
| 12. | Flask for condensate |
| 13. | Spring Clamp |
| 14. | Angled nozzle |
| 15. | Vacuum Valve |
| 16. | Pump Vent Valve |
| 17. | Controller Vent Valve |
| 18. | Vacuum Controller |
| 19. | On/off switch for Vacuum Controller |

Characteristics of D-LAB Pumps and D-LAB Systems:

- ★ The vacuum pumps are gas-tight, 100 % oil-free, maintenance-free and quiet.
- ★ High ultimate vacuum and fast pump down time.
- ★ All parts of the pump head in contact with gases being pumped are resistant against aggressive substances (materials: PTFE, FFKM, PVDF).
- ★ New valve system is very tolerant of water vapour and condensates.
- ★ Illuminated switch on pump.
- ★ Over-load protection by means of thermal cutout.
- ★ Compact design with space saving dimensions.
- ★ Changing of the diaphragms and valves in the vacuum pumps is a simple procedure.
- ★ The individual system components are easily integrated into one unit which can be progressively expanded.
- ★ The entire unit is mounted on a sturdy baseplate which makes it safe and easy to transport.
- ★ Individual components are easily removed because they all have plug in connectors.
- ★ Additional laboratory equipment can easily be mounted on the grooves holding the separator or on the support rods and horizontal bars.

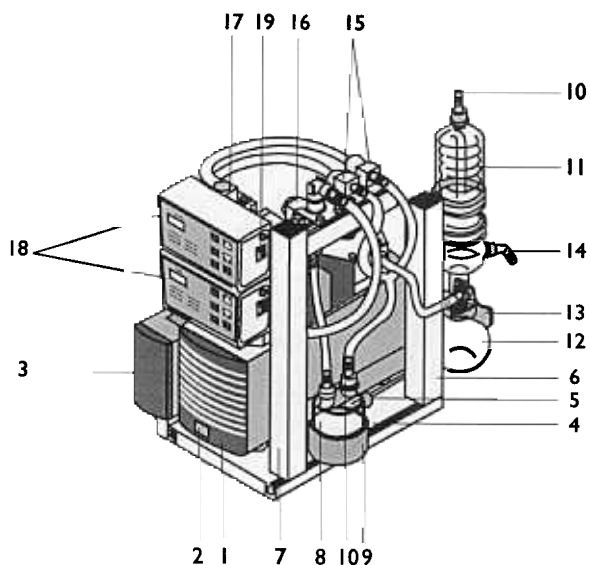

Figure 1: Complete expanded D-LAB System SCC eg. pump model D-LAB 34-8

Modular System.

Starting with a pump, it is possible to build up a system. The ultimate type is the SCC system which is capable of controlling two separate vacuum processes.

Vacuum Pump with two Separators (System SR)

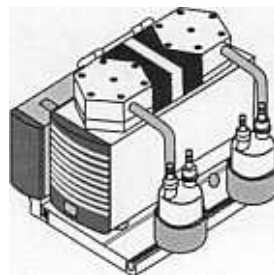

Figure 2: D-LAB system SR eg. pump model D-LAB 34-8

Condensable components in the gas can be separated on the exhaust side of the pump in order to prevent their escape into the environment. On the suction side the Separator collects any particulate matter and droplets. This protects the pump from contamination and ensures maximum continuous performance of the pump.

The Separator is made from specially treated glass and features implosion protection.

1.1.2 Vacuum Pump with Separator and High Performance Condenser (System SH)

The high performance Condenser enables condensable components in the vapour to be separated out and thereby removed from the atmosphere, at the same time protecting the environment.

The condensate is collected in a glass flask. The flask is

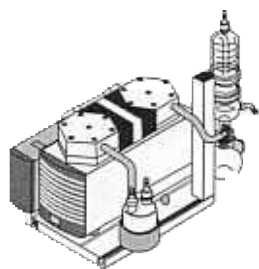

Figure 3: D-LAB system SH eg. pump model D-LAB 34-8

attached to the Condenser flange with a clamp. The condensation temperature is maintained by running cold water or recirculated coolant through the Condenser.

⚠ The condenser must be installed on the outlet side of the pump; if it is installed on the inlet side there is a danger of implosion.

.1.3 Vacuum Pump with Separator, High Performance Condenser and one Vacuum Controller (System SC)

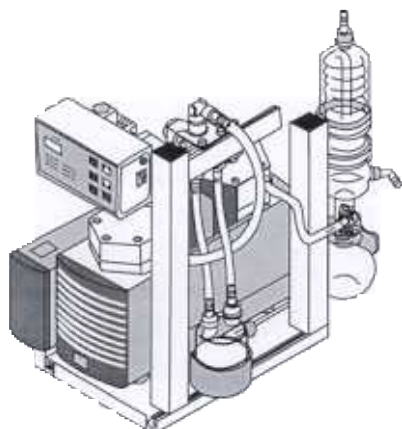

Figure 4: D-LAB System SC, eg. pump model D-LAB 34-8

Vacuum pumps in conventional laboratory systems operate continuously even after they reach their final vacuum level. D-LAB systems equipped with a Vacuum Controller enable the pump to be switched on and off between pre-set vacuum levels. Setting of the vacuum levels and differential pressure is via a keypad on the Vacuum Controller.

Features of the Vacuum Controller

- ★ Simple entry of the desired vacuum level and differential pressure.
- ★ Precise reproducibility of set values.
- ★ Facility to interrupt pumping program at any point.
- ★ The D-LAB system with Vacuum Controller automatically vents to atmosphere when switched off. This prolongs the operating life of the pump.
- ★ Easy venting of the system by touching the key pad.
- ★ One touch resetting from controlled pumping to maximum vacuum.
- ★ In the event of power failure the last entered values are retained.

.1.4 Vacuum Pump with Separator, High Performance Condenser and two Vacuum Controllers (system SCC)

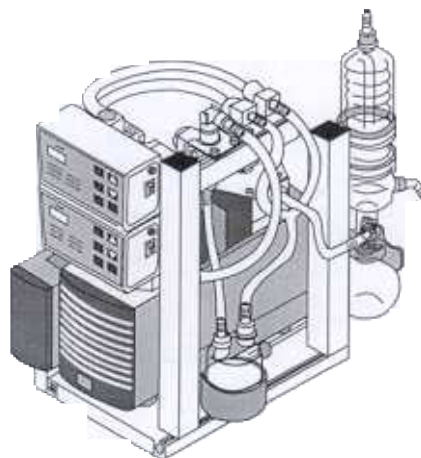

Figure 5: D-LAB system SCC, eg. pump model D-LAB 34-8

By adding a second Vacuum Controller two separate pumping applications may be carried out simultaneously and independently, using only one vacuum pump.

⚠ Ensure that the gases evolved from both processes can safely be mixed.

2. General Safety Precautions

⚠ Observe all applicable accident prevention regulations as well as generally recognised Health and Safety rules.

- ★ Parts of the casing marked with the sign opposite are only allowed to be opened after isolating the supply (disconnecting the power source).
- ★ Only authorized personnel should open those parts of the casing that contain live electrical parts.
- ★ Before using the D-LAB, carefully study the operating instructions. Avoid dangerous situations by observing the relevant instructions at all times.
- ★ Always keep the operating manual handy in the work area.
- ★ Before operation, ensure that the plastic plugs covering the inlet and outlet ports are removed.
- ★ Ensure that the pump system and its components are used only for those applications for which they were intended.
- ★ The equipment should only be connected to properly installed grounded outlets.
- ★ When cleaning the unit make sure that no fluids come into contact with the inside of the casing.
- ★ All pump models are fitted with protective thermal cut-outs. After operation of the thermal cutout or after a power failure the unit must be disconnected from the mains and then reconnected to reset the cut-out.
- ★ Do not operate the pump/D-LAB-system in an atmosphere containing explosive gases.
- ★ Use only original replacement parts.
- ★ Do not expose any part of your body to the vacuum.
- ★ Observe the specific safety precautions in section 4 of the Operating Instructions.

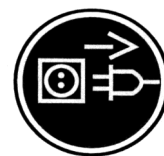

3. Assembling or Upgrading your System

3.1 Mounting the pump to the Baseplate (all systems)

Basic requirements for the assembly of a D-LAB-system are a D-LAB pump and a Baseplate. The mounting-system allows interchange of pump types on the baseplate without difficulties.

For mounting a D-LAB-pump to the baseplate the pump must be equipped with a mount (two components). Baseplates ordered separately (see 9.3 Accessories for the D-LAB) will contain the mounts.

Installation of the mounts on the pump:

- Unscrew the pump's rubber feet anticlockwise;
- Install the mounts onto the pump according to figure 6.

Mounting the pump to the Baseplate:

- Stand the pump (fitted with the mounts) on the baseplate and align the mounts on the pump and baseplate;
- Carefully slide the locating pin through the mount holes on the Baseplate and pump until they are fully engaged;
- Check that the pump is securely fastened to the Baseplate via both shock mounts.

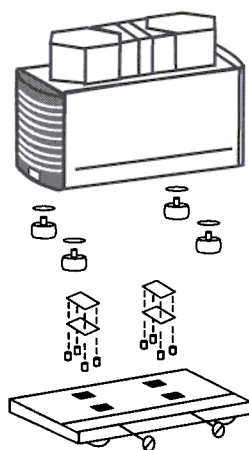

Figure 6: Pump Mounting Arrangement

Before interchanging pumps the pump on the baseplate must be disconnected from the electrical supply.

3.2 Assembling a System with Baseplate and two Separators

Baseplate: see 3.1

Separator:

- ★ The rubber hoses on the attachment nozzles can be readily exchanged.
 - ★ Required tool: 1 Philips-head screwdriver.
- Slide the holders for the Separators into the Baseplate mounting slot.
 - Fix the holders by tightening the screws in the bottom of them.
 - Place the glass Separators into the holders.
 - Tubing of twin head pumps: see figure 7. When connecting single head pumps, study the information sheet that accompanies the accessories. Choose tube material which is resistant to the media being used.

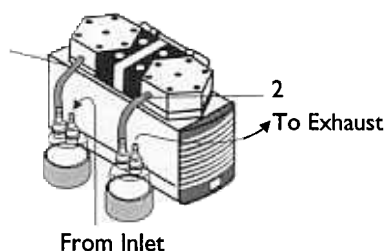

Figure 7: Tubing Connection SR

SR Tubing of twin head pumps:

- Approx. tube length 150mm
- Approx tube length 150mm
- 2 Tube inside diameter 10mm

3.3 Assembling a System with Baseplate, Separator and High Performance Condenser

Baseplate: see 3.1

Separator: see 3.2

Condenser:

- ★ For correct operation the high performance condenser requires a cold water connection or recirculated cooling system.
- ★ The condenser should be attached to the Support Post.
- ★ Required tool: 1 Allen key 5 mm.
 - Slide the support post (more exactly: its clamp assembly) into the end of the Baseplate Mounting Slot (positioning as shown in figure 1).
 - Fix the Support Post to the Baseplate by tightening the Allen screw on the Support Post.
 - Tubing see figure 8. Choose tube material which is resistant to the media to be used.

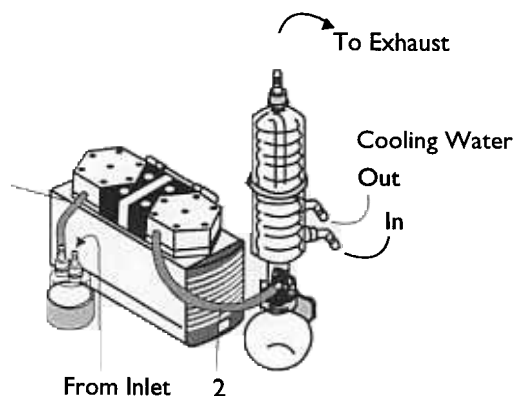

Figure 8: Tubing Connection SH (twin head pumps)

- △ Ensure that the vapour outlet on the top of the Condenser is not blocked e.g. due to kinks in the rubber tubing (danger of pressure build-up).

SH Tubing of two head pumps:

- Approx tube length 150mm
- Approx tube length 220 mm
- 2 Tube inside diameter 10mm

- ★ The condenser-connectors for the cooling water require connection tubing with an inside diameter of 8mm
- ★ Observe the correct usage of the gas- and cooling water-connections on the condenser (see figure 8). Inlet and outlet connections for the vapour side are not interchangeable.
- ★ When connecting the tubing, make sure that the pump's exhaust nozzle is always higher than the Condenser's inlet connection. This prevents any condensate that might form in the tube from running back into the pump head in large quantities.
- ★ Ensure that the coolant inflow and outflow are connected to the correct nozzles as indicated in figure 8.

3.4 Assembling a System with Baseplate, Separator, High Performance Condenser, Electrical Supply Unit and one Vacuum Controller

Baseplate: see 3.1
 Separator: see 3.2
 Condenser: see 3.3

Vacuum Controller/Electrical Supply Unit

See Figure 1

- ★ Required tools:
 - 1 Allen screw 4 mm.
 - 1 Allen screw 5 mm.
- ★ Vacuum Controller, ControllerVentValve and PumpVent Valve are already attached to the Vacuum Controller support post

Mounting the Electrical Supply Unit to the Baseplate:

- ★ The Electrical Supply Unit consolidates all of the electrical connections for the system and also controls the pump.
- ★ Slide the Electrical supply Unit (more exactly: its clamp assemblies) into the Baseplate.

Mounting Slot

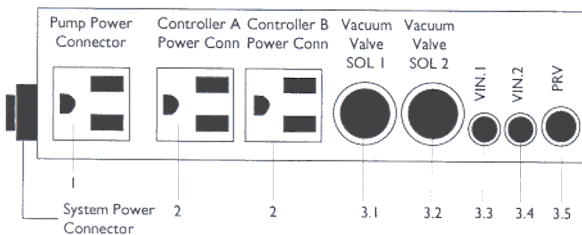

Figure 9: Connections on the Electrical Supply Unit (from system SC)

- ★ Fix the unit by tightening the two Allen screws at the bottom of the Electrical Supply Unit.
 - 1: Switched safety socket for pump
 - 2: Two safety sockets for Vacuum Controller.
- 3: Control functions:
 - 3.1 To vacuum valve 1
 - 3.2 To vacuum Valve 2 (only if system is operated with two Vacuum Controllers)
 - 3.3 To connecting wire of Vacuum Controller 1
 - 3.4 To connecting wire of Vacuum Controller 2 (only if system is operated with two Vacuum Controllers)
 - 3.5 To Pump vent valve

Mounting the Vacuum Controller and Valve Assembly

- ★ Slide the Support Post for the Vacuum Controller (more exactly: its clamp assembly) into the Baseplate Mounting Slot (orientation: see figure 4).
- ★ Fix the Support Post to the Baseplate by tightening the Allen screw on the Support Post.

SH Tubing of twin head pumps:

- 1 Approx tube length 220mm
- 2 Approx tube length 150mm
- 3 Approx tube length 300mm
- 4 Approx tube length 220mm
- 1-4 Tube inside diameter 10mm.

- ★ Tubing: see figure 10. Choose tube material which is resistant to the media to be used.
- ★ Tubing of twin head pumps: see figure 10. When connecting single head pumps, study the information sheet that accompanies the accessories. Choose tube material which is resistant against the media to be used.

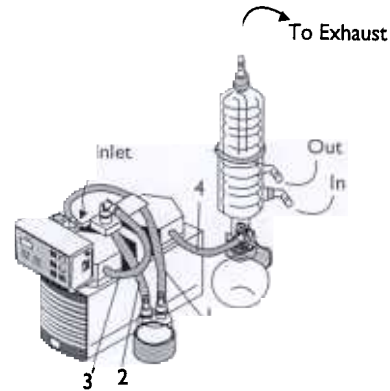

Fig. 10: Tubing Connection SC (twin head pumps).

Electrical Connection:

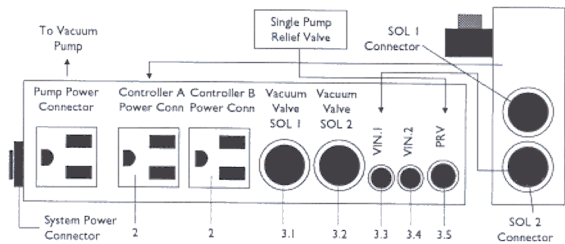

Figure 11: Electrical Connection System SC.

- ★ Connect Vacuum Controller-socket marked SOL.2 to the Electrical Supply Unit socket marked VIN 1 using the connection cable.
- ★ Insert the Vacuum Controller power cord plug into the Electrical Supply Unit socket marked ControllerA Power Connection.
- ★ Insert the PumpVentValve plug into the Electrical Supply Unit socket marked PRV.
- ★ Insert the vacuum pump power cord plug into the Electrical Supply Unit socket marked Pump Power Connector. To ensure correct functioning of the system the mains connection of the pump must be plugged into this designated socket.
- ★ Neatly tuck all of the wires into the Electrical Supply Unit and secure the cover.
- ★ Be sure all power switches (on the pump and on the Vacuum Controllers) are switched off. Insert the Electrical Supply Unit's system power cord plug into a suitably installed safety socket.

3.5 Assembling a System with Baseplate, Separator, High Performance Condenser, Electrical Supply Unit and two Vacuum Controllers.

The necessary steps for upgrading an existing D-LAB system to the ultimate system can commence from two possi-

ble starting points:

- ★ Existing system with Baseplate, Separator and high performance Condenser.
- ★ Existing system with Baseplate, Separator, high performance Condenser, Electrical Supply Unit, Support Bar for Vacuum Controller and one Vacuum Controller.

3.5.1 Existing system with Baseplate, Separator, Condenser

- ★ See also figure 1.
- ★ Required tools:
1 Allen key 4 mm.
1 Allen key 5 mm.
- ★ Both Vacuum Controllers, the Controller Vent Valves, the Pump Vent Valve and the Vacuum.
- ★ Valves are already attached to the Support bar for the Vacuum Controller.
- ★ Shut down the system (pull out the pump power plug). See section 5.

Mounting the Electrical Supply Unit to the Baseplate:

- ★ Slide the Electrical Supply Unit (more exactly: its clamping assemblies) into the Baseplate Mounting Slot.
- ★ Fix the unit by tightening the two Allen screws at the foot of the Electrical Supply Unit.

Mounting the Vacuum Controller Support Bar to the Baseplate:

- ★ Slide the Vacuum Controller Support Bar (more exactly: its clamping assembly) into the Baseplate Mounting Slot. Orientation: see figure 5.
- ★ Fix the Vacuum Controller Support Bar by tightening the Allen screw at the foot of the Support Post.

Tubing:

- ★ Tubing of twin head pumps: see figure 12. When connecting single head pumps, study the Information Sheet that accompanies the accessories. Choose tube material which is resistant to the media used.

SCC Tubing of twin head pumps:

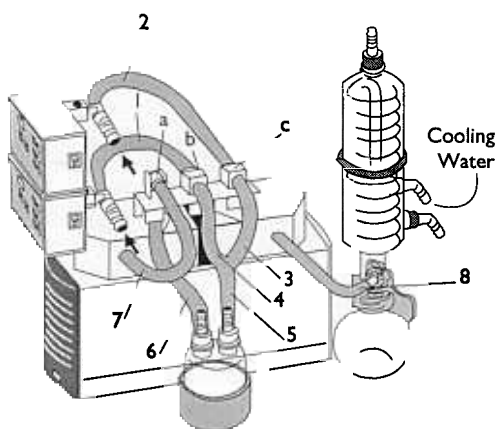

Figure 12: Tubing Connection SCC (twin head pumps)

- 1 Approx tube length 320mm
- 2 Approx tube length 260mm
- 3 Approx tube length 120mm
- 4 Approx tube length 120mm

- 5 Approx tube length 135mm
 - 6 Approx tube length 175mm
 - 7 Approx tube length 350mm
 - 8 Approx tube length 220mm
- 1-8 Tube inside diameter 10mm

Electrical Connections

See Figure 13

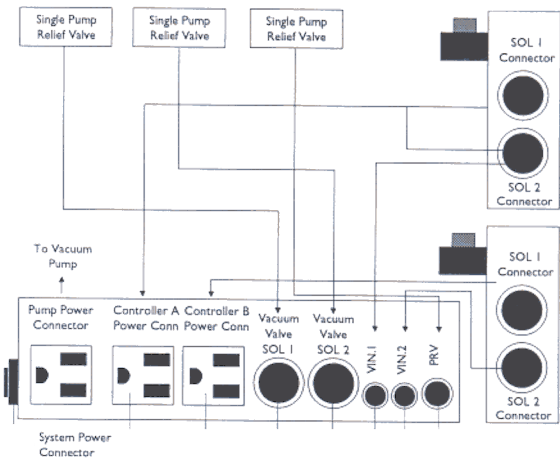

Figure 13: Electrical Connection System SCC

- ★ Connect both Vacuum Controller connections SOL 2 to the Electrical Supply Unit Connections VIN.1 and VIN.2 using the connecting cables.
- ★ Insert the Vacuum Controllers power cord plugs into the Electrical Supply Unit sockets marked Controller A Power Conn. and Controller B Power Conn.
- ★ Insert the plugs from both Vacuum Valves into the Electrical Supply Unit sockets marked SOL.1 and SOL.2.
- ★ Insert the plug from the Pump Vent Valve into the Electrical Supply Unit socket marked PRV.
- ★ Insert the Vacuum Pump plug into the power socket inside the Electrical Supply Unit marked Pump Power Controller.
- ★ To ensure correct functioning of the system the mains connection of the pump must be plugged into this designated socket.
- ★ Neatly tuck all of the wires into the Electrical Supply Unit and secure the cover.
- ★ Be sure all power switches (pump, Vacuum Controllers) are off. Plug the Electrical Supply Unit's system power cord plug into a suitable safety socket.

3.5.2 Existing System with Electrical Supply Unit, Support Bar and One Vacuum Controller

- ★ See also figure 1
- ★ Required tool:
1 Allen screw 4 mm.
- ★ Second Vacuum Controller including Controller Vent Valve is already attached to the new Support bar for the Vacuum Controller (length: 410 mm).

Disassembly

- ★ Shut down the system (see section 5) (pull out the Electrical Supply Unit power plug).

- ★ Disconnect the tubes from the Pump Vent Valve as well as from the Controller Vent Valve.
- ★ Pull out all plugs from the Electrical Supply Unit.
- ★ Remove the Vacuum Controller from the Support Post after loosening the clamp assembly.
- ★ Remove the Valve Support Post from the Controller Support Post after loosening the clamp assembly.
- ★ Remove the Controller Support Post from the Baseplate:
 - Loosen the Allen screw at the foot of the Vacuum Controller Support Post.
 - Slide it out of the Baseplate Mounting Slot.

Assembly

- ★ Mount the existing controller onto the new Controller Support Post: Slide the Vacuum Controller (more exactly: its clamping assembly) into the Vacuum Controller Support Post Mounting Slot and fix the Vacuum Controller by tightening the Allen screw.
- ★ Slide the Vacuum Controller Support Post (more exactly: its clamping assembly) into the Baseplate Mounting Slot.
- ★ Fix the Vacuum Controller Support Post by tightening the Allen screw at the foot of the Support Post.
- ★ Mount the Valve Support Post onto the Controller Support Post.
- ★ Slide the holding device for the Vacuum Valves (including Vacuum Valves) onto the Valve Support Post Mounting Slot and fix the device with help of the clamping assembly.
- ★ Tubing of two headed pumps see figure 12. When connecting single head pumps, study the Information Sheet that accompanies the accessories. Choose tube material which is resistant to the media being used.
- ★ Electrical connection: see section 3.5.1.

3.6 Mounting of Gas Ballast (option for twin head pumps)

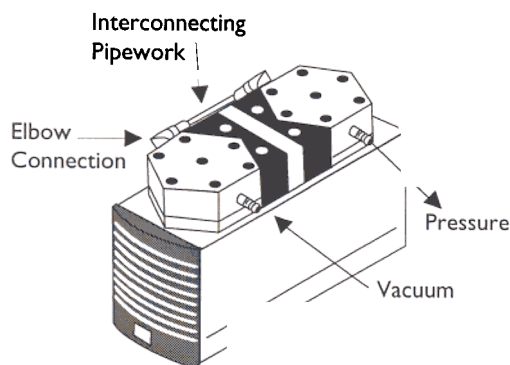

Figure 14: Gas Ballast

- ★ Shut down the system (see section 5) and isolate the power supply. From the relevant Electrical Supply Unit.
- ★ Disconnect the tubes from the inlet and the outlet of the pump.
- ★ Remove the pump from the Baseplate.
- ★ Remove the pipe work connecting the pump heads (see figure 14).
- ★ Unscrew the connecting piece from the vacuum side of the head. (See figure 14).
- ★ Screw the Gas Ballast device into the pump head the threads are sealed with PTFE tape.
- ★ Reassemble the connection between both the pump heads.

4. Operating Instructions

4.1 General Notes

Before using the vacuum pump or the D-LAB system please observe the following points:

- ★ Choose a safe location (flat surface) for the equipment.
- ★ Ensure that the vacuum pump is securely fastened to the Baseplate. The two locating pins underneath the pump must be locked in position.
- ★ Laboratory equipment or additional components connected to a D-LAB - pump or a D-LAB - system must be compatible with the physical capabilities of the pump.
- ★ When using the high performance condenser the system must be connected to a cold water supply or a recirculating cooler.
- ★ When using two Vacuum Controllers: two controllers should only be used with gases which can be mixed safely together.
- ★ Don't operate the pump/D-LAB-system in an atmosphere containing explosive gases.

Before getting started:

- ★ Specific safety instructions for the media being handled must be observed.
- ★ Observe all safety regulations when handling: corrosive, explosive, microbiological, radioactive, toxic and other dangerous materials.
- ★ Ensure the pump outlet is not closed or restricted and adequate ventilation allowed.

If using a Condenser:

- ★ Ensure that the vapour outlet on the top of the Condenser is never blocked (a kink in the exhaust hose could cause pressure build up).

Check:

- ★ All clamping connections for tightness.
 - ★ Tubing for correct connection.
 - ★ Electrical connections for correct connection.
- Be sure to connect the system to the correct electrical power supply as specified on the identification labels located on the Vacuum Pump and the Electrical Supply Unit.

4.2 Operating conditions

General operating conditions of the pump and system (including Electrical Supply Unit and Vacuum Controller):

- ★ Permissible ambient temperature: + 5°C to + 40°C.
- ★ Do not operate pump/system in an atmosphere containing explosive gases.
- ★ Protect pump and system against humidity.

Additional operating conditions of the pump:

- ★ Liquids must not be pumped.
- ★ Permissible temperature of gas to be pumped: + 5°C to + 40°C.
- ★ Do not operate the pump with excess pressure on the exhaust side.
- ★ If the pump stops e.g. due to power failure the pump has to be vented manually. Pump systems using a Vacuum Controller will automatically vent through the Pump Vent Valve.
- ★ The quantity of air or gas should be regulated or throttled only on the suction side of the pump. If regulation is needed on the exhaust side, do not exceed the design

nated maximum pressure of the pump.

- ★ The ventilation openings on the pump must not be obstructed to ensure sufficient cooling for the motor.
- ★ The pumps can operate continuously even after final vacuum level is attained.
- ★ Be sure to connect the system to the correct electrical power supply as specified on the identification labels located on the Vacuum Pump and on the Electrical Controller.

4.3 Operation of the Pump System

- ★ The vacuum pump can be switched on and off using the power switch located below the ventilation inlet. (See Figure 1, item 2).
- ★ D-LAB-systems with Vacuum Controller(s): can be switched on and off using the power switch(es). (See Figure 1, item 19).

4.3.1 Operation with Baseplate and two Separators

The Separator

The Separator, made of specially treated glass, features implosion protection and may be installed on either the suction side, on the exhaust side, or on both sides of the pump. The holders which contain the Separators can be repositioned if necessary by loosening the screw and sliding them along the groove.

Emptying and Cleaning of the Separator:

- ★ Unscrew the two connecting nozzles.
- ★ Remove the Separator from the holder, empty and rinse.
- ★ Replace Separator into the holder.
- ★ Screw the attachment nozzles back on.

4.3.2 Operation with Baseplate, Separator and High Performance Condenser

Separator:

See Section 4.3.

High performance Condenser:

- ★ The condenser must be installed on the outlet side of the pump; if it is installed on the inlet side there is a danger of implosion.
- ★ Ensure that the vapour outlet on the top of the condenser is not restricted. e.g. due to kinks in the tubing.

Emptying and cleaning the condenser

- ★ Carefully remove the spring clamp while supporting the flask.
- ★ Empty and clean the flask - observing safety precautions.
- ★ Reconnect the flask to the condenser and replace the spring clamp.

Adjustment of the Condenser Height

Required tool: 1 Allen key 5 mm

- ★ Loosen the both Allen screw at the foot of the Condenser.
- ★ Reposition the Condenser clamp assembly in the Support Mounting Slot.

- ★ Retighten the Allen screws.

4.3.3 Operation with Baseplate, Separator, High Performance Condenser, Electrical Supply Unit and one Vacuum Controller

Separator:

See Section 4.3.1

High performance Condenser:

See Section 4.3.2

Electrical Supply Unit

- ★ Disconnection of the Electrical Supply Unit from the power source is achieved by pulling out the plug.

Vacuum Controller Display Elements

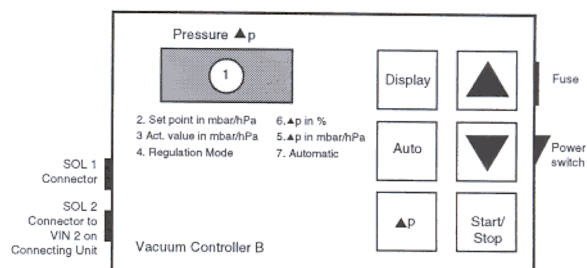

Figure 15: Vacuum Controller

Meaning of the LEDs:

1. Seven segment display for vacuum (mbar), Δp (mbar) and Δp (%).
2. Setpoint in mbar /hPa: Preset vacuum is on display.
3. Actual Value in mbar/hPa: Actual system vacuum is on display.
4. Regulation Mode: Normal operation is activated.
5. Δp in %: Preset vacuum is activated, Δp in % on display.
6. Δp in mbar/hPa: Preset vacuum is activated, Δp in mbar/hPa on display.
7. Automatic: Automatic operation and preset vacuum are activated.

Using the Keypad

Display key

Alternates the display in regulation mode between "Act.Value in mbar" and "Setpoint in mbar". Automatically reverts to "Act.Value" after 10 seconds.

Auto key

Automatically corrects preset value (see section 4.3.3.3).

Δp key

Sets differential pressure (see section 4.3.3.2).

Arrow up key

Increases set vacuum or differential pressure.
 - one-touch: single step adjustment.
 - hold down: running adjustment.

Arrow down key

Decreases set vacuum or differential pressure.

Start/Stop key

One-touch: to activate the Regulation Mode.
 Hold down: to ventilate and to evacuate without regulation.

4.3.3.1 Setting the vacuum level

- ★ Switch on pump.
 - ★ Switch on Vacuum Controller:
 - "Setpoint" display element illuminates or flashes.
 - ★ When the LED stops flashing, and is continuously on (after about 5 seconds) set the desired vacuum level using the up and down arrow keys.
 - ★ Press "Start/stop" key:
 - Set value is memorised.
 - Pump operates.
- or
- ★ When the pump is already operating and an actual vacuum value needs to be retained:
 - ★ When the required value shows on the display press down arrow key - vacuum level is memorised.
 - ★ The last entered vacuum value is memorised after the system is shut off.

4.3.3.2 Setting the Pressure Differential

The hysteresis function enables setting and adjustment of the differential pressure above that of the programmed vacuum level at which the pump should start again. This can be programmed either as a percentage or directly as a pressure difference (in mbar).

- a. Switch on Pump.
- b. Switch on Vacuum Controller - "Setpoint" display element flashes.
- c. Select mode (% or mbar) by using the Δp key - the appropriate display element is illuminated.
- d. Set the desired Δp value using the up and down arrows.
- e. Press "start/stop" key: Δp value is memorised.

The Δp value last entered will be retained in the memory when the system is shut down.

4.3.3.3 Automatic Adjustment of Pre-Set Vacuum Level

The automatic correction feature only functions when the preset Δp value is equal to or greater than 3 %. (See section 4.3.3.2).

If after reaching a preset vacuum level (chapter 4.3.3.1) the pump restarts too often, the "Auto" key will automatically adjust the preset value. The preset value is automatically adjusted by increments of 5 mbar up to a maximum of 10 such increments whenever the pump restarts at least twice within an interval of 8 seconds.

If the activation frequency of the pump is still too high after the 10 increments (plus 50 mbar), i.e. the maximum automatic incremental adjustment has been reached, the display element will flash slowly as a signal. A new cycle of automatic incremental adjustment can be initiated by pressing the "Auto" key.

During normal operation the "Auto" key turns the automatic incremental adjustment feature on and off. This feature remains activated after venting (see section 4.3.3.8) and can be turned off by pressing the "Auto" key.

4.3.3.4 Starting the System Pumping

For interrupting the pumping cycle see section 4.3.3.5.

- a. Switch pump on.
- b. Switch Vacuum Controller on:
 - "Setpoint" display element flashes or illuminates. The preset vacuum level last entered is shown on the display.

Press "Start/Stop" key.

The actual vacuum value is displayed.

"Act.Value" display element illuminates.

"Regulation Mode" display element illuminates.

Pump will start and continue pumping until preset value is reached.

4.3.3.5 Interrupting Pumping

A pump progressing towards a preset vacuum level may be interrupted at any time.

- a. Press "Start/Stop" key.
 - The preset vacuum level is displayed.
 - "Setpoint" display element flashes.

4.3.3.6 Restarting after interrupting pumping cycle

- a. Press "Start/Stop" key
 - Actual vacuum level is displayed.
 - "Act.Value" display element illuminates.
 - "Regulation Mode" display element illuminates.

4.3.3.7 Continuous Pumping to Ultimate Vacuum/Drying Mode

If the desired vacuum is greater than the preset level or the drying mode is required:

- a. Press "Start/stop" key
 - "Setpoint" display element flashes.
- b. Press "Start/Stop" key until the "Regulation Mode" display element goes out
 - "Act.Value" display element illuminates.
- c. Press "Start/Stop" key to stop pumping.

4.3.3.8 Venting the System

If the vacuum system is to be vented or purged with an inert gas:

- a. Press the "Start/Stop" key firmly until the Vent Valve opens (2 to 3 seconds).

The actual value is displayed.

"Act.Value" display

element illuminates.

After the system has vented, display shows set vacuum level.

"Setpoint" display element illuminates.

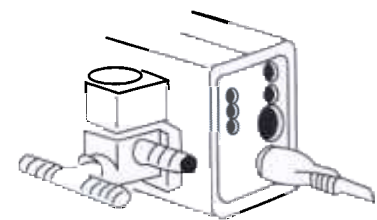

Figure 16: Connection of inert gas source to the Vacuum Controller Valve.

Warning: The inert gas pressure on the inlet must not exceed 0.3 bar g

Rapid venting while the pump is running:

- ★ Press the Arrow up key
 - the venting valve operates immediately
 - the valve remains open as long as the Arrow Up Key is pressed
 - the vacuum controller memorised the new setpoint

4.3.3.9 Setting of the Ventilation Limits

This feature guarantees safe stopping of the system irrespective of the operating altitude or if the inlet of the venting valve is under pressure.

- a. Switch on the Controller.
Display flashes 5 seconds and indicates either the factory set value of 1020 mbar or the last entered value.
- b. During this time the limiting values are input by the up arrow/down arrow keys (value should be approximately 5 to 8 mbar over atmospheric pressure).
- c. 5 seconds after the last operation with the up arrow/down arrow keys the new limit will be memorised.

4.3.4 Operation with Baseplate, Separator, High Performance Condenser, Electrical Supply Unit and Two Vacuum Controllers.

Warning: Where two separate processes are in operation, ensure that the evolved gases can be safely mixed.

Separator:

see section 4.3.

High performance Condenser:

see section 4.3.2

Controller:

A pump system with two Controllers can control two separate processes simultaneously and independently. This is made possible by using two Vacuum Valves each controlled by one Vacuum Controller.

Each of the two Vacuum Controllers operate in the same manner (see sections 4.3.3). Each Vacuum Controller functions independently of the other and can be separately set.

Once the preset vacuum level on one of the Vacuum Controllers has been reached, the Vacuum Valve that it controls will close. The pump, however, may continue to operate until the preset vacuum on the other Vacuum Controller is reached. The second Vacuum Valve then closes; the pump shuts off and the Pump Vent Valve opens.

Once the pump has vented, it restarts only when one of the differential pressures exceeds the preset level.

4.3.5 Gas Ballast Option

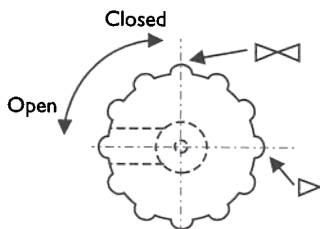

Figure 17: Use of the Gas Ballast Control Knob.

Use of the gas ballast option increases the pump's ability to prevent condensation build up.

If the gas ballast valve is open the maximum achievable vacuum level is reduced.

5. System Shutdown

- ★ Clean the containers.
- ★ Purge the complete pump system including the connecting hoses with air for about 5 minutes.
- ★ Shut down the power to the system.
- ★ Disconnect the power source to the Electrical Supply Unit.

6. Troubleshooting

6. System without vacuum controller

Insufficient Vacuum Performance:

Possible reasons:

- ★ Tube connections are not tight.
- ★ Condensate in the pump head (remove the source of condensation from the pump or consider using gas ballast valve option).
- ★ Diaphragms and/or valve plates are worn out (changing diaphragms and valve plates: see section 7).
- ★ If this problem occurs after changing of diaphragms, valve plates and/or O-rings: see information in section 7.

Pump is switched on, but does not run and the on/off-switch on the pump is not lit.

Possible reasons:

- ★ Pump is not connected to the power source.
- ★ No voltage at the power source.
- ★ Fuse in the pump is defective (only authorized/qualified personnel should investigate this problem! Disconnect the pump from the power source, the fuse is accessible after opening the marked cover at the bottom of the pump. Dimension of the fuse: see section 8).

Pump is switched on, but does not run and the on/off-switch on the pump is lit.

Possible reasons:

- ★ The heat sensitive circuit breaker has cut in because of the pump overheating (disconnect the pump from the power source, let the pump cool down, investigate the reason for the overheating and eradicate it).

6.2 System with one Controller

Insufficient Vacuum Performance

Possible reasons:

- ★ As for system without vacuum controller (see under a).
- ★ Additional possible reason: solid particles in the Pump Vent Valve.
- ★ If condensation occurs in the pump head, set the pump to Drying Mode according to section 4.3.3.7.

Controller is switched on and set to "Regulation Mode", the desired vacuum level is not reached, pump does not run and the on/off-switch on the pump is not lit.

Possible reasons:

- ★ Pump is not switched on.
- ★ Incorrect electrical connection.
- ★ Fuse in the pump is defective (see "System without Controller" under a).

Controller is switched on and set to "Regulation Mode", the desired vacuum level is not reached, pump does not run and the on/off-switch on the pump is lit.

Possible reasons:

- ★ The heat sensitive circuit breaker has cut in because of the pump overheating (disconnect the pump from the

power source, let the pump cool down, investigate the reason for the overheating and eradicate it).

Controller is switched on, no LED-indication.

Possible reasons:

- ★ In the Electrical Supply Unit the Vacuum Controller plug is plugged into the socket for the pump.
- ★ The fuse in the vacuum controller is defective (the fuse is located above the on/off switch of the controller). (*Dimension of the fuse: see section 8*).
- ★ The fuse in the Electrical Supply Unit is defective (the fuse is located at the end of Electrical Supply Unit below the mains connection). (*Dimension of the fuse see section 8*).

Controller shows unrealistic values.

Possible reasons:

- ★ The controller requires recalibrating (contact your supplier).
- ★ The sensor is defective (contact your supplier).

6.3 System with two Controllers.

See system with one controller (under b).

System does not work, despite one controller (both controllers) being set on "Regulation Mode".

Possible reason:

- ★ In the Electrical Supply Unit the connecting wires for the Vacuum Controllers are plugged in incorrectly (exchange the plugs between Vacuum Controller 1 and Vacuum Controller 2).
- ★ In the Electrical Supply Unit the connecting wires for the Vacuum Valve are plugged in incorrectly (exchange the plugs between Vacuum Valve 1 and Vacuum Valve 2).

7. Changing the Diaphragms and the Valve Plates

In the case of twin head pumps the diaphragms in both pump heads should be changed at the same time. When diaphragms are changed, valve plates should also be replaced. If the diaphragms are not changed in both heads at the same time or diaphragms and valves are not changed at the same time the nominal performance of the pump cannot be guaranteed after the service.

Required tools and material:

- ★ 1 Service Set (see section 9.2).
- ★ Required tool:
 - 1 Philips-head screwdriver No. 2

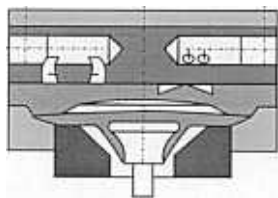

Figure 18: Cross section of the pump head



Figure 19: O-Ring and Valve Plate

7.1 Single Head Pumps:

D-LAB 10-100
D-LAB 20-100
D-LAB 34-100

Preparatory Steps

- ★ Shut down the system (see section 5) including disconnecting from the power source.
- ★ Remove tubing from the inlet and outlet connectors of the pump.
- ★ If the pump is integrated in a vacuum system: remove pump from the baseplate.

Removing the Pump Head

- ★ Loosen the 6 outer screws on pump head.
- ★ Carefully remove the pump head.

Changing the diaphragm

- ★ Carefully unscrew the diaphragm anticlockwise.
- ★ Replace all shim washers onto the screw thread of the new diaphragm.
- ★ Screw in the new diaphragm (do not overtighten).
- ★ Press the lip on the edge of the diaphragm into the groove in the housing.

Changing the Valve Plates

- ★ Unscrew the single screw in the top plate pump head.
- ★ Carefully remove the top plate; exposing the sealing rings and the valve plates.
- ★ Carefully remove old sealing rings and valve plates.
- ★ Insert new sealing rings and valve plates.
- ★ Reposition the top plate of the pump head.
- ★ Screw in the single screw in the centre of the pump top plate until it is flush with the top plate; then screw one final half turn to tighten (do not overtighten).

7.2 Twin Head Pumps:

D-LAB 10-8
D-LAB 20-8
D-LAB 34-8

Preparatory Steps

- ★ Shut down the system (see section 5) including disconnecting from the power source.
- ★ Remove tubing from the inlet and outlet connectors of the pump.
- ★ If the pump is integrated in a vacuum system: remove pump from the baseplate.

Removing the Pump Head

- ★ Remove the interconnecting pipework connecting both pump heads.
- ★ Loosen the 6 outer screws on each pump head.
- ★ Carefully remove the pump head.

Changing the diaphragm

- ★ Push down one diaphragm until other diaphragm is pushed upwards to its highest position.
- ★ Carefully unscrew the diaphragm anticlockwise.
- ★ Replace all shim washers onto the screw thread of the new diaphragm.
- ★ Press down the accessible connecting rod to move the second diaphragm upwards to its highest point.
- ★ Carefully unscrew the second diaphragm as described

above.

- ★ Screw in the new diaphragm (do not overtighten).
- ★ Press the lip on the edge of the diaphragm into the groove in the housing.

Changing the Valve Plates

- ★ Unscrew the single screw in the top plate of one pump head.
- ★ Carefully remove the top plate; exposing the sealing rings and the valve plates.
- ★ Carefully remove old sealing rings and valve plates.
- ★ Insert new sealing rings and valve plates.
- ★ Reposition the top plate of the pump head.
- ★ Screw in the single screw in the centre of the pump top plate until it is flush with the top plate; then screw one final half turn to tighten (do not overtighten).
- ★ Repeat the above steps for the second pump head.

Refitting the Pump Head

- ★ Replace the pump head (note guide pin) and securely tighten screws in a crosswise pattern.
- ★ Reassemble interconnecting pipework connecting both pump heads.
- ★ Remount the pump to the Baseplate (if applicable).
- ★ Reconnect tubing.

If the pump does not reach the desire vacuum after changing diaphragms and/or valve plates:

- ★ Check whether the shim washers have been replaced onto the diaphragm screw thread.
- ★ Check the interconnecting pipework connection between both pump heads as well as the tubing for leaks.
- ★ Possibly the screws on one of the pump heads (or both heads) are insufficiently tightened (carefully tighten them again crosswise).

8. Ordering Information

8. D-LAB Vacuum Pumps

Model	Order Number
D-LAB 10-100, 110V, 60Hz	
D-LAB 10-100, 220 - 240V, 50Hz	
D-LAB 10-100, 100V, 50/60Hz	
D-LAB 20-100, 110V, 60Hz	
D-LAB 20-100, 220 - 240V, 50Hz	
D-LAB 10-100, 100V, 50/60Hz	
D-LAB 34-100, 110V, 60Hz	
D-LAB 34-100, 220 - 240V, 50Hz	
D-LAB 10-100, 100V, 50/60Hz	
D-LAB 10-8, 110V, 60Hz	
D-LAB 10-8, 220 - 240Hz	
D-LAB 10-100, 100V, 50/60Hz	
D-LAB 20-8, 110V, 60Hz	
D-LAB 20-8, 220 - 240V, 50Hz	
D-LAB 10-100, 100V, 50/60Hz	
D-LAB 34-8, 110V, 60Hz	
D-LAB 34-8, 220 - 240V, 50Hz	
D-LAB 10-100, 100V, 50/60Hz	

8.2 Replacement Parts Service Set

Single Head Pumps

Service set includes 1 diaphragm, 2 sealing rings and 2 valve plates.

Pump	Order Number

Twin Head Pumps

Service set includes 2 diaphragms, 4 sealing rings and 4 valve plates.

Pump	Order Number

8.3 Accessories for the modular D-LAB - System

Item	Order Number
Baseplate	
D-LAB 10-100, 20-100, 10-8 and 20-8	A480-15-134
D-LAB 34-100, and 34-8	A480-21-134
Vapour Trap*	
Gas Ballast control Valve	
D-LAB 10-100, 10-8	A480-15-135
D-LAB 20-100, 34-100, 20-8 and 34-8	A480-17-135
Vacuum Controller Complete Including Support Post & Electrical Supply Unit 220-240V, 50Hz	A480-15-138
Vacuum Controller Complete Including Support Post & Electrical Supply Unit 100-110V, 50/60Hz	A480-15-139
Electrical Supply Cable with IEC socket (for 220 - 240V)	
UK Three pin plug	A505-05-000
North European plug	A505-06-000
No plug	A505-08-000

9. Specifications

D-LAB 10-100

Maximum capacity:	10 l/min
Ultimate vacuum:	≤ 100 mbar abs
Maximum continuous pressure:	bar g (14.7 psi)
Permissible ambient temp:	+5...+40°C
Permissible temp. of gas to be pumped:	+5...+40°C
Weight of pump:	5.9 kg

Electrical Specification			
Voltage (V)	100	115	230
Power Consumption Pump (W)			
Fuse Pump (2x) T (A)	2.5	2.5	2.5

D-LAB 20-100

Maximum capacity:	20 l/min
Ultimate vacuum:	≤ 100 mbar abs
Maximum continuous pressure:	bar g (14.7 psi)
Permissible ambient temp:	+5...+40°C
Permissible temp. of gas to be pumped:	+5...+40°C
Weight of pump:	7.1 kg

Electrical Specification			
Voltage (V)	100	115	230
50/60			
Power Consumption Pump (W)			
Fuse Pump (2x) T (A)	4.0	3.5	2.0

D-LAB 34-100

Maximum capacity:	34 l/min
Ultimate vacuum:	≤ 100 mbar abs
Maximum continuous pressure:	bar g (14.7 psi)
Permissible ambient temp:	+5...+40°C
Permissible temp. of gas to be pumped:	+5...+40°C
Weight of pump:	10.3 kg

Electrical Specification			
Voltage (V)	100	115	230
Power Consumption Pump (W)			
Fuse Pump (2x) T (A)	6.3	6.3	2.5

D-LAB 10-8

Maximum capacity:	10 l/min
Ultimate vacuum:	≤ 8 mbar abs
Maximum continuous pressure:	bar g (14.7 psi)
Permissible ambient temp:	+5...+40°C
Permissible temp. of gas to be pumped:	+5...+40°C
Weight of pump:	6.9 kg

Electrical Specification			
Voltage (V)	100	115	230
Power Consumption Pump (W)			
Fuse Pump (2x) T (A)	2.5/12	2.5	1.25

D-LAB 20-8

Maximum capacity:	20 l/min
Ultimate vacuum:	≤ 8 mbar abs
Maximum continuous pressure:	bar g (14.7psi)
Permissible ambient temp:	+5 ...+40° C
Permissible temp. of gas to be pumped:	+5 ...+40° C
Weight of pump	9.3 kg

Electrical Specification			
Voltage (V)	100	115	230
Power Consumption Pump (W)			
Fuse Pump (2x) T (A)			

D-LAB 34-8

Maximum capacity:	4 l/min
Ultimate vacuum:	≤ 8 mbar abs
Maximum continuous pressure:	bar g (14.7psi)
Permissible ambient temp:	+5 ...+40° C
Permissible temp of gas to be pumped:	+5 ...+40° C
Weight of pump:	12.6 kg

Electrical Type			
Voltage (V)	100	115	230
Power Consumption Pump (W)			
Fuse Pump (2x) T (A)	6.3	6.3	3.15

9.2 Electrical Supply Unit

Electrical Type			
Voltage (V)	100	115	230
Power Consumption Pump (W)			
Fuse Pump (2x) T (A)	6.3	6.3	3.15

9.3 Vacuum Controller

Electrical Type			
Voltage (V)	100	115	230
Power Consumption Pump (W)			
Fuse Pump (2x) T (A)	0.2	0.2	0.1

CE - Safety Requirements

The D-LAB pumps correspond to the safety regulations of the EG low voltage directive 73/23 EWG and of the EG directive concerning electromagnetic compatibility 89/336 EWG. The requirements of the following harmonised standards are fulfilled: EN 61010 part 1, EN 50081 part 1, EN 50082 part 1.

The pumps correspond to IEC 664:

- ★ The overload category II.
- ★ The pollution degree 2.

10. Performance Graphs

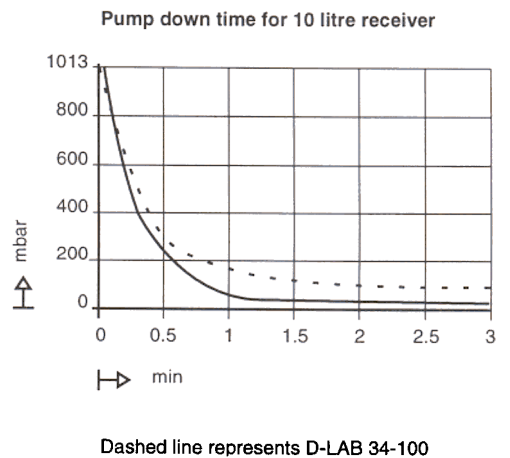
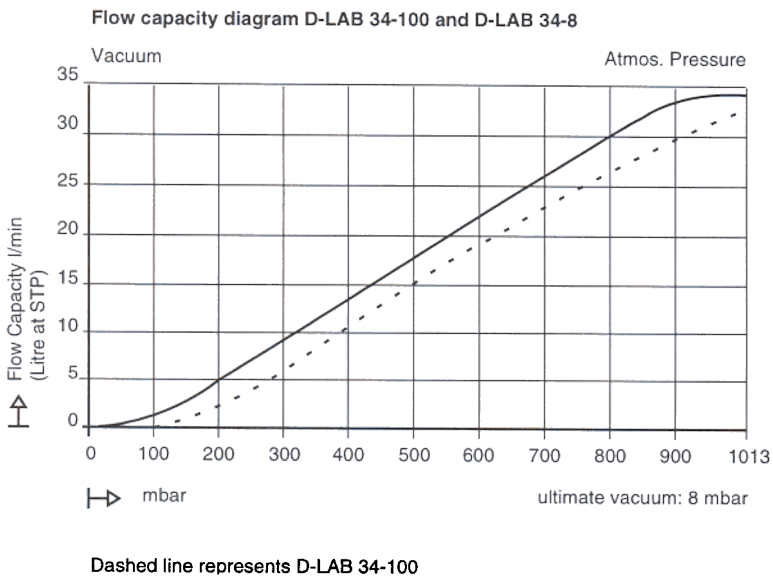
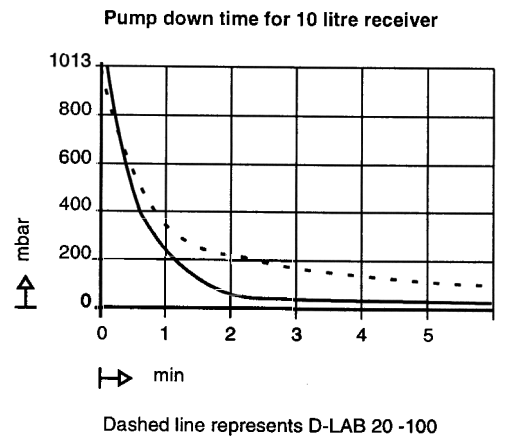
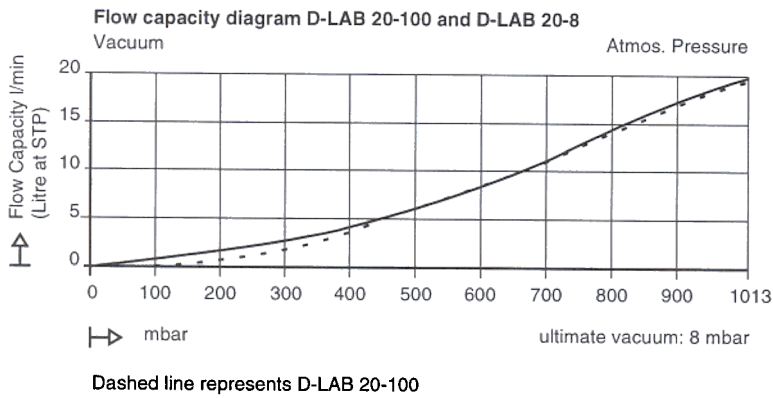
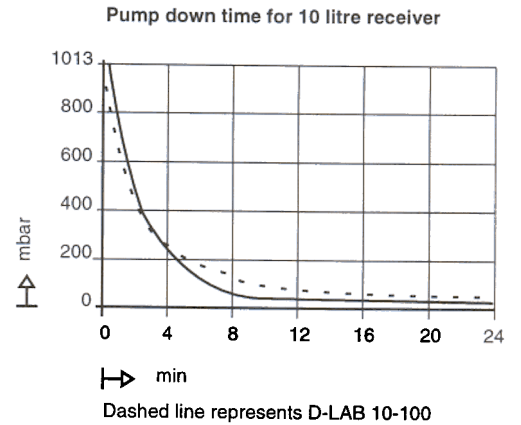
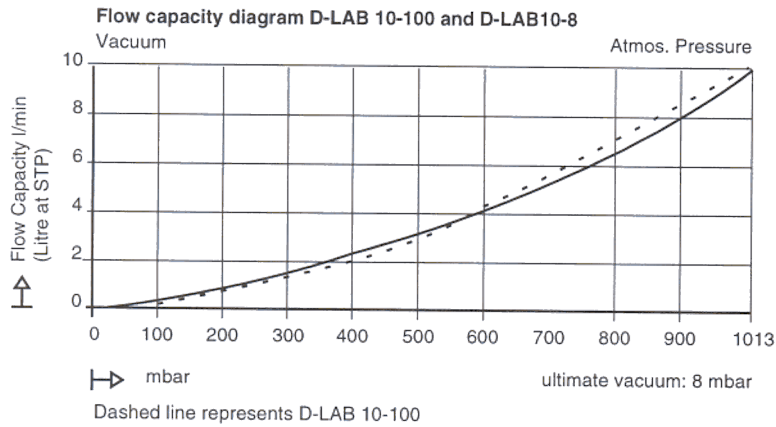

Return the equipment or components for service

Before you send your equipment to us for service or for any other reason, you must send us a completed Declaration of Contamination of Vacuum Equipment and Components - Form HS2. The HS2 form tells us if any substances found in the equipment are hazardous, which is important for the safety of our employees and all other people involved in the service of your equipment. The hazard information also lets us select the correct procedures to service your equipment.

We provide instructions for completing the form in the Declaration of Contamination of Vacuum equipment and Components - Procedure HS1.

If you are returning a vacuum pump, note the following:

- If a pump is configured to suit the application, make a record of the configuration before returning the pump. All replacement pumps will be supplied with default factory settings.
- Do not return a pump with accessories fitted. Remove all accessories and retain them for future use.
- The instruction in the returns procedure to drain all fluids does not apply to the lubricant in pump oil reservoirs.