



nXRi HIGH PERFORMANCE COMPACT DRY VACUUM PUMP

Edwards has revolutionised the vacuum pump market with the new nXRi high performance, compact dry pump. It delivers unrivalled pumping speeds in the most compact package, with pumping speeds of 30 to 120 m³h⁻¹. The nXRi's lower input power and zero maintenance create real performance improvements and cost benefits across a range of applications.

Analytical Instrument OEMs benefit from the ease of integration into most vacuum systems for a ready to go vacuum solution, perfect for mass spectrometry, electron microscopy and leak detection. R&D and Industrial customers will enjoy the design flexibility, oil-free and low maintenance features.



Compact footprint
Optimise your space!

Unrivalled performance
When you need it!

Energy efficiency
Reduce your costs!

Zero contamination
Experience the difference!

Features and benefits

- 1 Designed with size in mind, the compact footprint and height allow the nXRi dry pump to fit easily under a benchtop saving valuable space in your laboratory; and at under 30kg offers a highly portable vacuum pump for changing work flows and environments.
- 2 When performance matters look no further than the nXRi dry pump, with pumping speed performance of 30 to 120 m³h⁻¹ from our most compact footprint. It delivers six times more pumping speed than similar sized dry pumps, and with low ultimate and high reliability you are assured a consistent and stable vacuum for years to come.
- 3 For reduced power consumption look no further than the Edwards nXRi dry pump, optimised to low power for lower energy costs and reduced heat load from your vacuum equipment.
- 4 Clean processes and clean results are guaranteed with the nXRi compact dry pump, being totally oil-free and dust-free within the vacuum chamber. Being free of oil, smells and particulates guarantees a more pleasant working environment.

Technical data

Peak pumping speed	
nXR30i	30 m ³ h ⁻¹
nXR40i	40 m ³ h ⁻¹
nXR60i	60 m ³ h ⁻¹
nXR90i	90 m ³ h ⁻¹
nXR120i	120 m ³ h ⁻¹
Ultimate vacuum (total pressure)	
	0.03 mbar (0.022 Torr)
Inlet flange	
nXR30/40i	NW25
nXR60/90/120i	NW40
Outlet flange	
All variants	NW25
Maximum permitted outlet pressure	
nXR30/40/60/90/120i	0.2 bar gauge
Maximum continuous inlet pressure	
nXR30-90i	1013 mbar
nXR120i	20 mbar
Operating temperature range	
	+5 to +40°C (+41 to +104°F)
Nominal rotational speed	
	15000 rpm
Voltage input	
	100-127/200-240 V (+/-10%), switchable
Mains frequency	
	50/60 Hz
Power connector 1-ph	
	IEC EN60320 C19
Power at ultimate	
	450 W
Leak tightness	
	< 1x10 ⁻⁶ mbar ls ⁻¹
Weight	
nXR30/40i	27 kg (60 lbs)
nXR60/90/120i	29 kg (64 lbs)
Noise at ultimate vacuum	
	55 dB(A)
Vibration at inlet flange	
	< 2.0 mm/s

Ordering information

Product description	Order number
nXR30i NW25 Multi Stage Roots Dry Pump 100-127/200-240V 50/60 Hz	A90301983
nXR40i NW25 Multi Stage Roots Dry Pump 100-127/200-240V 50/60 Hz	A90401983
nXR60i NW40 Multi Stage Roots Dry Pump 100-127/200-240 V, 50/60 Hz	A90502983
nXR90i NW40 Multi Stage Roots Dry Pump 100-127/200-240 V, 50/60 Hz	A90602983
nXR120i NW40 Multi Stage Roots Dry Pump 100-127/200-240V 50/60 Hz	A90702983

Dimensions

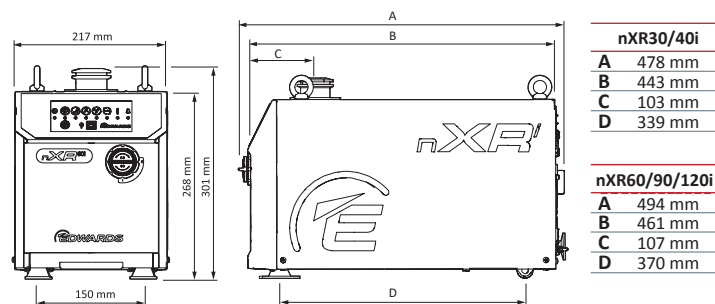

Pumping performance

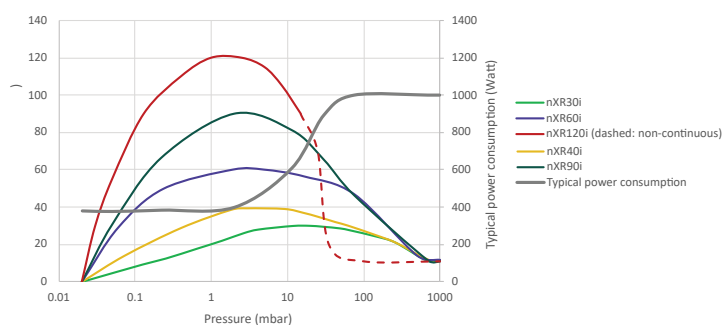

Accessories

Product description	Order number
2m electrical supply cable, NEMA 5-15P, North America/Japan (100-120 V)	A50507003
2m electrical supply cable, NEMA 6-15P, North America (200-240 V)	A50507006
2m electrical supply cable, UK, three pin plug	A50505003
2m electrical supply cable, Europe	A50506003
2m electrical supply cable, China	A50509003
Gas ballast blank plug	A73501806
Gas ballast adaptor for inert gas (1/4" quick connect)	A73501811
Floor/cart mounting kit	A90590000

Chemtech Scientific provides access to this content as a courtesy. We do not own the content contained in this document. All rights and credit go directly to its rightful owners.
www.chemtechsci.com
 Call us at: 484-424-9415

