

# Instruction Manual

## ESDP12 and ESDP30 Scroll Pumps

Chemtech Scientific provides access to this content as a courtesy.  
We do not own the content contained in this document.  
All rights and credit go directly to its rightful owners.  
[www.chemtechsci.com](http://www.chemtechsci.com)  
Call us at: 484-424-9415



Description	Item Number	Description	Item Number
ESDP12 Scroll Pump	A710-02-909	ESDP30 Scroll Pump, 1-phase, 100/115/200/230 V, 50/60 Hz	A710-03-909
ESDP30 Scroll Pump, 3-phase, 200/208/230/380-460 V, 50/60 Hz	A710-03-907		

# Contents

Section	Page
<b>1 Introduction</b> .....	<b>1</b>
1.1 Scope and definitions .....	1
1.2 Description .....	2
<b>2 Technical data</b> .....	<b>5</b>
2.1 Mechanical data .....	5
2.2 Performance and operating conditions .....	5
2.3 Electrical data .....	10
2.4 Noise and vibration data .....	11
2.5 Materials exposed to vacuum .....	11
<b>3 Installation</b> .....	<b>13</b>
3.1 Safety .....	13
3.2 System requirements .....	13
3.3 Unpack and inspect .....	14
3.4 Reconfigure the ESDP30 pump (optional) .....	14
3.5 Locate the pump .....	15
3.6 Connect the electrical supply .....	16
3.6.1 Introduction .....	16
3.6.2 Connect to ESDP12 pumps .....	16
3.6.3 Connect to ESDP30 3-phase pumps .....	17
3.6.4 Connect to ESDP30 1-phase pumps .....	17
3.7 Check the direction of motor rotation .....	21
3.8 Connect the pump-inlet to the vacuum system .....	21
3.9 Connect the pump-outlet .....	22
3.10 Leak test the pump installation .....	22
<b>4 Operation</b> .....	<b>23</b>
4.1 Start-up .....	23
4.2 Shut-down .....	23
<b>5 Maintenance</b> .....	<b>25</b>
5.1 Introduction .....	25
5.2 Remove debris from the pump .....	25
5.3 Inspect the inlet screen .....	25
5.4 Service the pump .....	25
<b>6 Storage and disposal</b> .....	<b>27</b>
6.1 Storage .....	27
6.2 Disposal .....	27
<b>7 Spares and accessories</b> .....	<b>29</b>
7.1 Introduction .....	29
7.2 Accessories .....	29

For return of equipment, complete the HS Forms at the end of this manual.

## Illustrations

Figure		Page
1	The ESDP12 pump .....	3
2	The ESDP30 pump (3-phase pump shown) .....	4
3	ESDP12 pump dimensions (mm) .....	6
4	ESDP30 pump dimensions (mm): 3-phase pump shown .....	7
5	ESDP12 pumping speed/pressure graph (m <sup>3</sup> h <sup>-1</sup> ) .....	8
6	ESDP12 pumping speed/pressure graph (cfm) .....	8
7	ESDP30 pumping speed/pressure graph (m <sup>3</sup> h <sup>-1</sup> ) .....	9
8	ESDP30 pumping speed/pressure graph (cfm) .....	9
9	ESDP12 motor terminal-box .....	18
10	ESDP30 motor terminal-box low-voltage configuration: 3-phase pumps .....	19
11	ESDP30 motor terminal-box high-voltage configuration: 3-phase pumps .....	19
12	ESDP30 motor terminal-box low-voltage configuration: 1-phase pumps .....	20
13	ESDP30 motor terminal-box high-voltage configuration: 1-phase pumps .....	20

## Tables

Table		Page
1	ESDP12 pump full load current ratings and motor speed .....	10
2	ESDP30 pump full load current ratings and motor speed: 3-phase pumps .....	10
3	ESDP30 pump full load current ratings and motor speed: 1-phase pumps .....	10

# 1 Introduction

## 1.1 Scope and definitions

This manual provides installation, operation and maintenance instructions for the Edwards ESDP12 and ESDP30 Scroll Pumps. You must use the pumps as specified in this manual.

Read this manual before you install and operate the pumps. Important safety information is highlighted as **WARNING** and **CAUTION** instructions; you must obey these instructions. The use of **WARNINGS** and **CAUTIONS** is defined below.



### **WARNING**

Warnings are given where failure to observe the instruction could result in injury or death to people.

---

### **CAUTION**

Cautions are given where failure to observe the instruction could result in damage to the equipment, associated equipment and process.

---

The units used throughout this manual conform to the SI international system of units of measurement. For displacement and pumping speed, the term 'cfm' is also used to mean  $\text{ft}^3\text{min}^{-1}$ .

The following symbol appears on the pumps:



Warning - risk of electric shock.

## 1.2 Description

The ESDP12 and ESDP30 Scroll Pumps are compact, reliable vacuum pumps for use on clean dry processes. The pumps are **not** suitable for use with explosive, flammable, toxic or corrosive substances, or substances which contain particulates, powders or vapour.

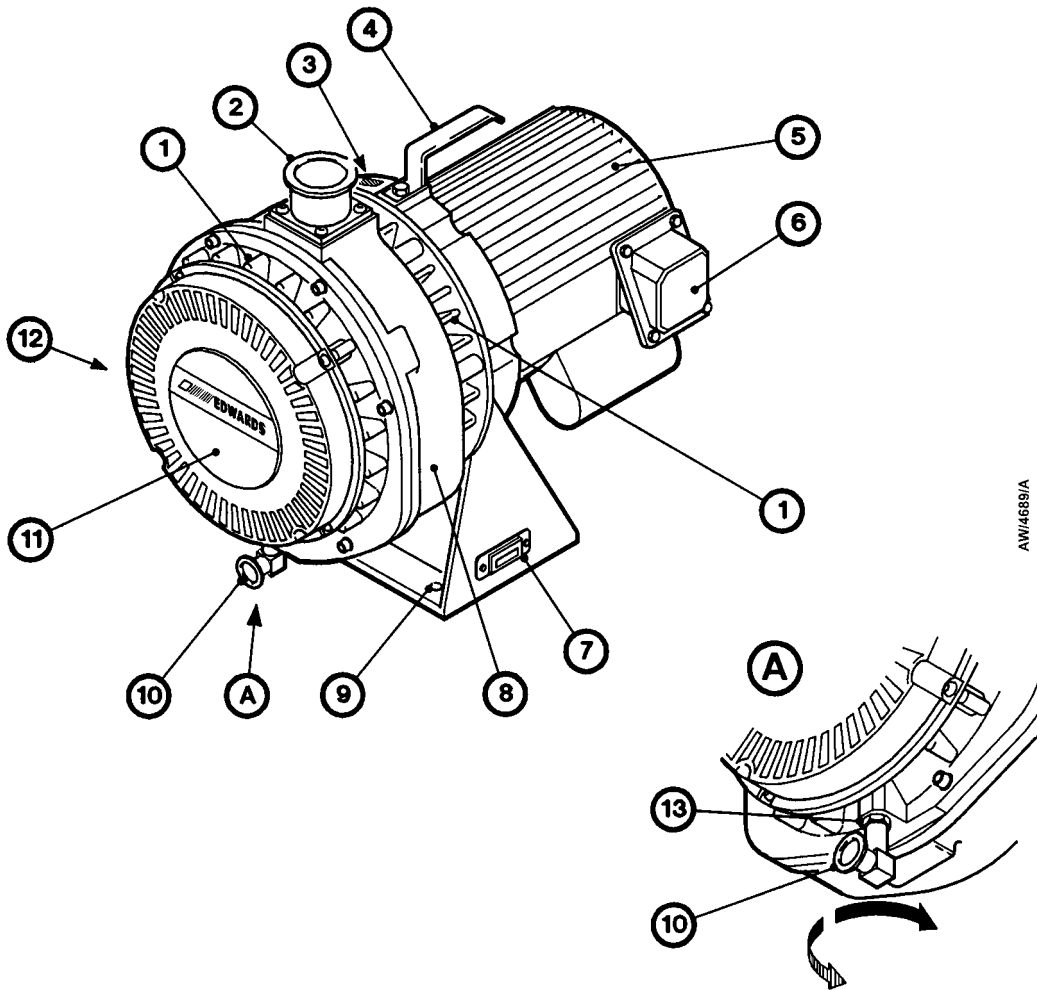
The body of the pump has stationary scrolls and an orbiting scroll. The orbiting scroll is driven by the electric pump-motor through an eccentric cam on the motor drive shaft. The movement of the orbiting scroll, meshed with the stationary scrolls, forms successive crescent shaped volumes in the pump.

Gas which enters the pump through the inlet is compressed by the movement of the orbiting scroll and swept towards the centre of the stationary scrolls. The compressed gas enters the exhaust-port near the centre of the stationary scrolls and is exhausted from the pump through the outlet.

The inlet of the pump has an inlet screen which prevents the entry of debris into the pump.

The pump is air-cooled and has an electric motor and an hours counter which operates when the electrical supply to the pump is switched on.

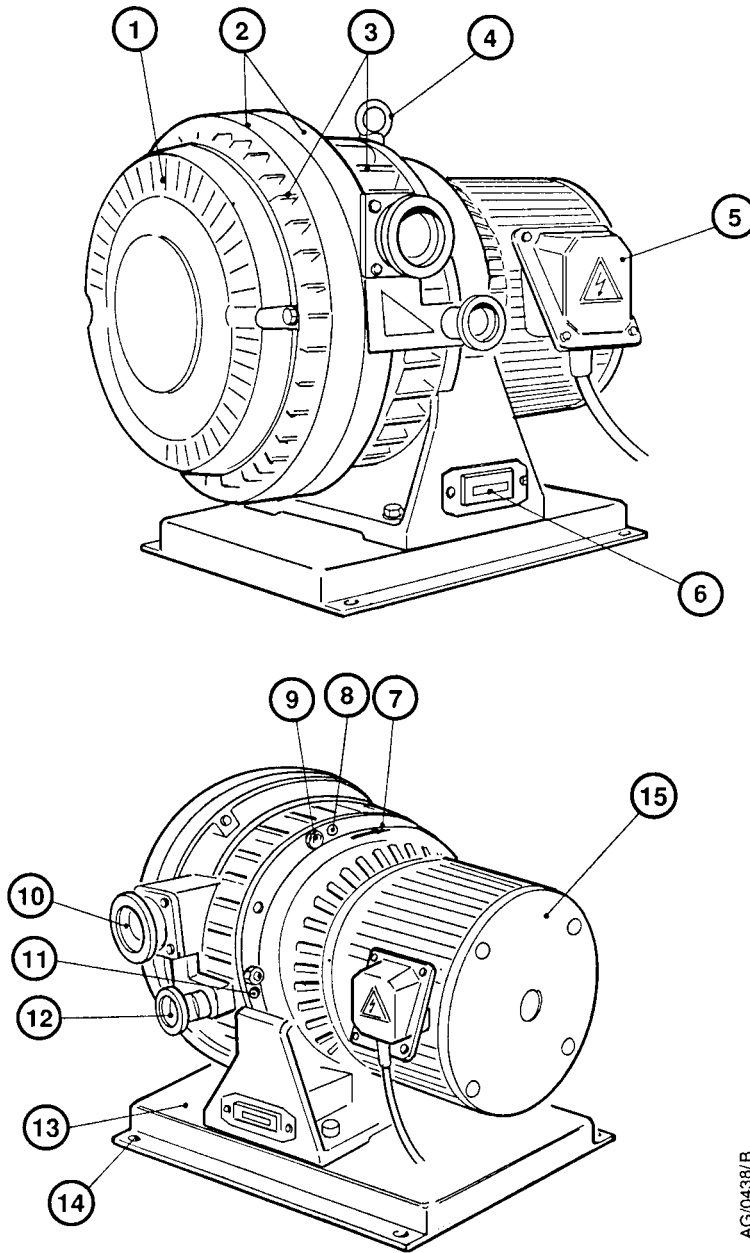
Figure 1 - The ESDP12 pump



AW/4689/A

- |                                |                           |
|--------------------------------|---------------------------|
| 1. Cooling-fins                | 8. Stationary scrolls     |
| 2. Inlet                       | 9. Mounting-holes (4 off) |
| 3. Direction of rotation arrow | 10. Outlet                |
| 4. Lifting-handle              | 11. Fan cover             |
| 5. Pump-motor                  | 12. Rating plate          |
| 6. Motor terminal-box          | 13. Locknut               |
| 7. Hours counter               |                           |

Figure 2 - The ESDP30 pump (3-phase pump shown)



AG/0438/B

- |                                |                                           |
|--------------------------------|-------------------------------------------|
| 1. Fan cover                   | 9. Coupling-cover bolts (6 off)           |
| 2. Stationary scrolls          | 10. Inlet and inlet screen (in the inlet) |
| 3. Cooling-fins                | 11. Jacking hole                          |
| 4. Lifting-eye                 | 12. Outlet                                |
| 5. Motor terminal-box          | 13. Base-plate                            |
| 6. Hours counter               | 14. Mounting-holes (4 off)                |
| 7. Direction of rotation arrow | 15. Motor end-cover                       |
| 8. Locating dowels             |                                           |

## 2 Technical data

### 2.1 Mechanical data

	ESDP12	ESDP30
Overall dimensions	See Figure 3	See Figure 4
Mass	25 kg	40 kg*, 46 kg <sup>†</sup>
Inlet connection	NW25	NW40
Outlet connection	NW16	NW25

### 2.2 Performance and operating conditions

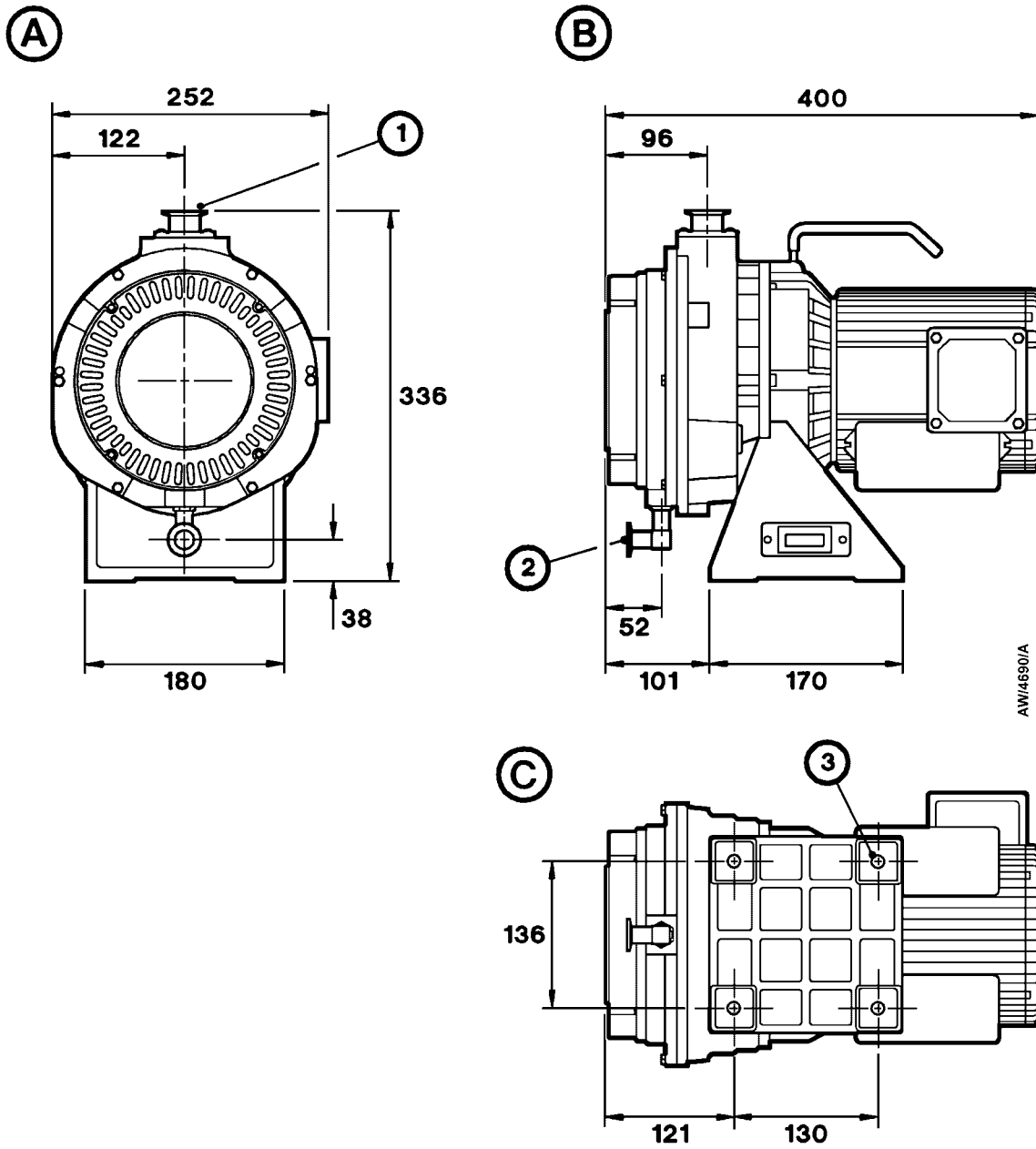
	ESDP12	ESDP30
Ambient operating temperature range	5 to 40°C	5 to 40°C
Ambient storage temperature range	-20 to 60°C	-20 to 60°C
Ultimate pressure	$<1.6 \times 10^{-2}$ mbar, 1.6 Pa	$1 \times 10^{-2}$ mbar, 1 Pa
Maximum inlet pressure	1000 mbar, $1 \times 10^5$ Pa, 0 psig	1000 mbar, $1 \times 10^5$ Pa, 0 psig
Maximum outlet pressure	1150 mbar, $1.15 \times 10^5$ Pa, 2 psig	1150 mbar, $1.15 \times 10^5$ Pa, 2 psig
Leak tightness	$<1 \times 10^{-4}$ mbar.l.s <sup>-1</sup> , $1 \times 10^{-2}$ Pa.l.s <sup>-1</sup>	$<1 \times 10^{-4}$ mbar.l.s <sup>-1</sup> , $1 \times 10^{-2}$ Pa.l.s <sup>-1</sup>
Displacement (swept volume)		
50 Hz	15 m <sup>3</sup> h <sup>-1</sup> (8.8 cfm)	30 m <sup>3</sup> h <sup>-1</sup> (17.6 cfm)
60 Hz	18 m <sup>3</sup> h <sup>-1</sup> (10.6 cfm)	36 m <sup>3</sup> h <sup>-1</sup> (21.2 cfm)
Pumping speed	See Figures 5 and 6	See Figures 7 and 8
Peak pumping speed		
50 Hz	12.5 m <sup>3</sup> h <sup>-1</sup> (7.3 cfm)	25 m <sup>3</sup> h <sup>-1</sup> (14.7 cfm)
60 Hz	15 m <sup>3</sup> h <sup>-1</sup> (8.8 cfm)	30 m <sup>3</sup> h <sup>-1</sup> (17.6 cfm)

\* 3-phase pump

† 1-phase pump

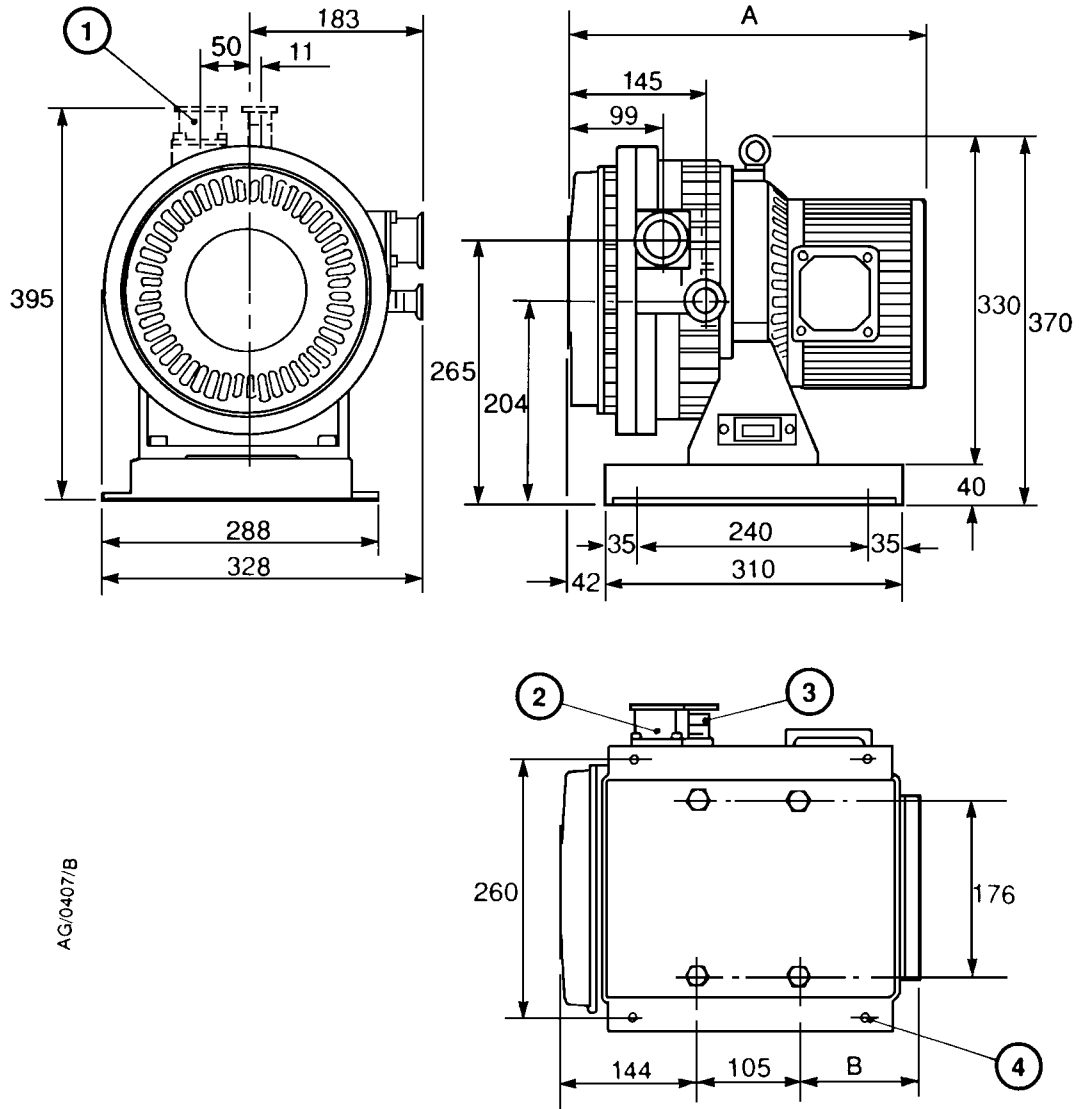


Figure 3 - ESDP12 pump dimensions (mm)



- |                 |                                             |
|-----------------|---------------------------------------------|
| A. Front view   | 1. Inlet                                    |
| B. Side view    | 2. Outlet                                   |
| C. View of base | 3. Mounting-holes: $\varnothing 11$ (4 off) |

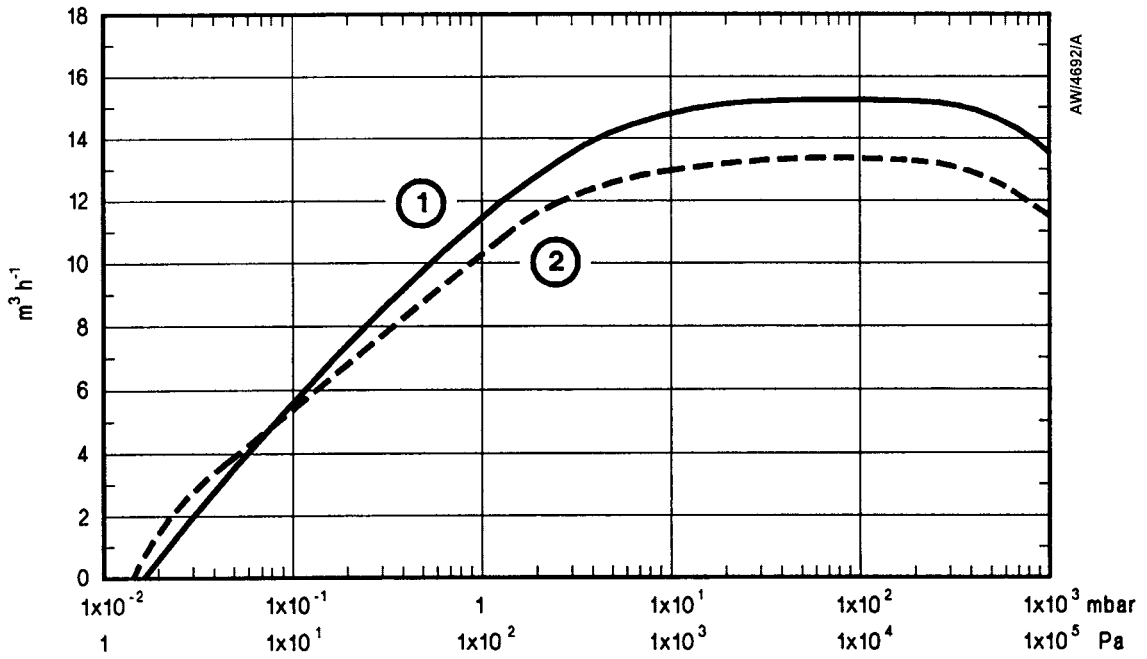
Figure 4 - ESDP30 pump dimensions (mm): 3-phase pump shown



1. Alternative inlet and outlet positions
2. Inlet
3. Outlet
4. Mounting-holes for M8 bolts (4 off)

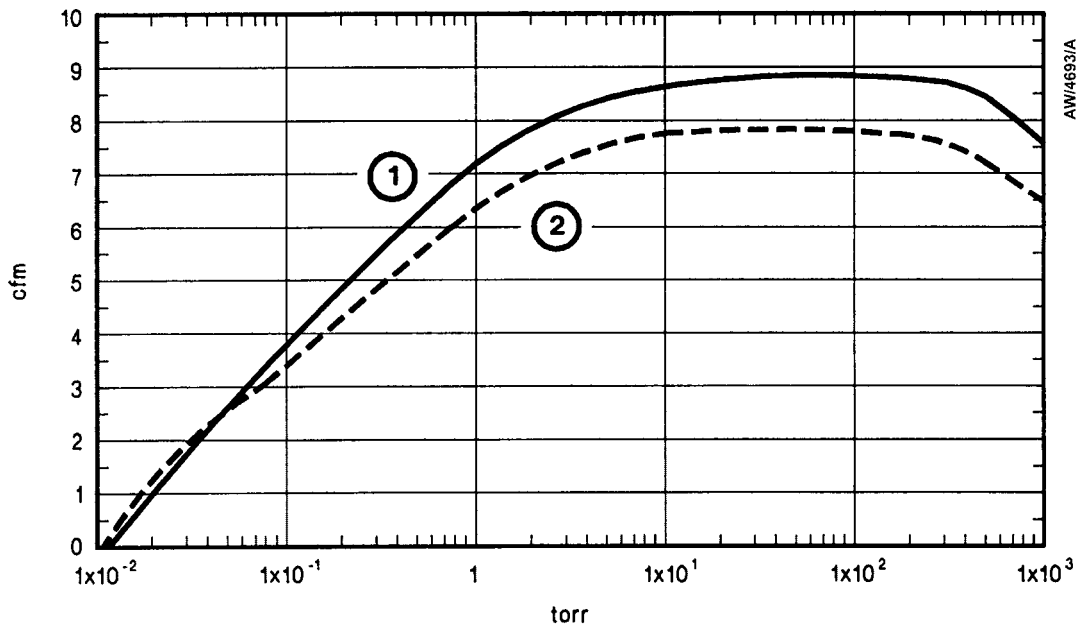
Pump	A	B
1-phase	443	194
3-phase	372	123

Figure 5 - ESDP12 pumping speed/pressure graph ( $m^3h^{-1}$ )



- 1. 60 Hz
- 2. 50 Hz

Figure 6 - ESDP12 pumping speed/pressure graph (cfm)



- 1. 60 Hz
- 2. 50 Hz

Figure 7 - ESDP30 pumping speed/pressure graph ( $m^3h^{-1}$ )

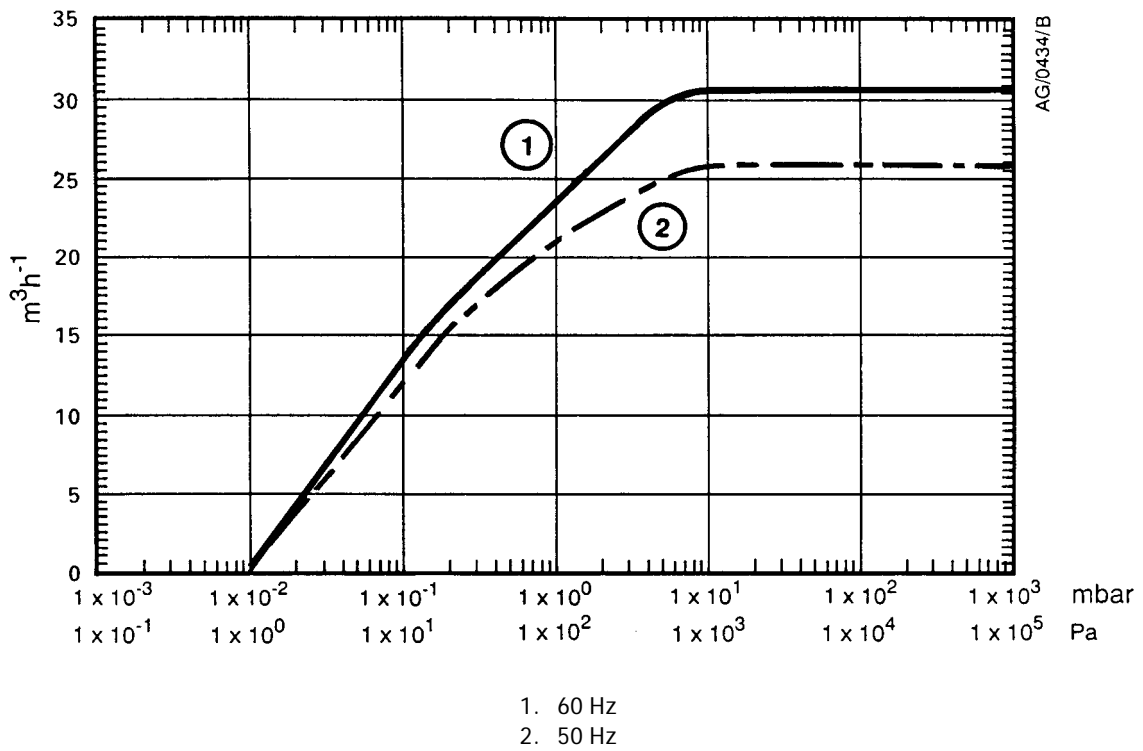
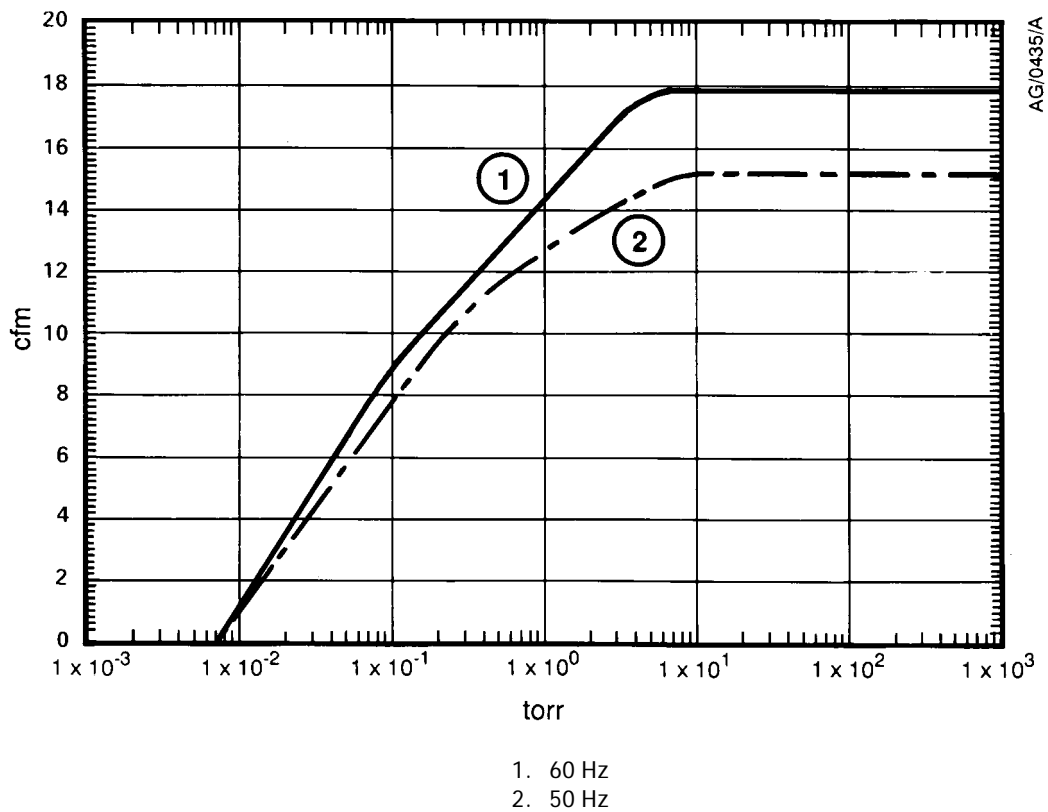


Figure 8 - ESDP30 pumping speed/pressure graph (cfm)



## 2.3 Electrical data

	ESDP12	ESDP30
Electrical supply	See Table 1	See Tables 2 and 3
Full load current ratings	See Table 1	See Tables 2 and 3
Motor type	0.4 kW, 1-phase, squirrel cage induction motor, TEFC, 4-pole, B class insulation capacitor run.	

Table 1 - ESDP12 pump full load current ratings and motor speed

		Electrical supply voltage			
		100	115	200	230
Full load current rating: A	50 Hz	4.2	-	2.0	2.2
	60 Hz	4.3	3.8	2.2	1.9
Motor rotational speed: r.min <sup>-1</sup>	50 Hz	1430	-	1420	1440
	60 Hz	1720	1740	1710	1730

Table 2 - ESDP30 pump full load current ratings and motor speed: 3-phase pumps

		Electrical supply voltage					
		200	208	230	380	415	460
Full load current rating: A	50 Hz	2.7	-	-	1.57	1.63	-
	60 Hz	2.6	2.5	2.5	-	-	1.47
Motor rotational speed: r.min <sup>-1</sup>	50 Hz	1460	-	-	1470	1470	-
	60 Hz	1740	1750	1760	-	-	1770

Table 3 - ESDP30 pump full load current ratings and motor speed: 1-phase pumps

		Electrical supply voltage			
		100	115	200	230
Full load current rating: A	50 Hz	8.5	-	4.3	3.9
	60 Hz	7.7	6.7	3.9	3.4
Motor rotational speed: r.min <sup>-1</sup>	50 Hz	1430	-	1430	1450
	60 Hz	1720	1740	1720	1740

## 2.4 Noise and vibration data

	ESDP12	ESDP30
Noise level (at 1 m from the pump)	≤58 dB(A)	<60 dB(A)* <62 dB(A)†
Vibration velocity	<1.5 mm.s <sup>-1</sup>	<1.5 mm.s <sup>-1</sup>

\* 3-phase pump

† 1-phase pump

## 2.5 Materials exposed to vacuum

PTFE (polytetrafluoroethylene) impregnated aluminium, stainless steel, steel bearings, PFPE (perfluoropolyether) grease, fluoroelastomer seals.

## 3 Installation

### 3.1 Safety



#### **WARNING**

Obey the safety instructions given below and take note of appropriate precautions. If you do not, you can cause injury to people and damage to equipment.

- A suitably trained and supervised technician must install your ESDP pump.
- Ensure that the installation of the pump conforms with all the requirements of your local and national safety standards. Ensure that your control system is configured so that the pumping system is safe if the electrical supply fails.
- Ensure that the installation technician is familiar with the safety precautions for the gases processed by the pumping system. Wear the appropriate safety-clothing when you come into contact with contaminated components. Vent and purge the pumping system before you start installation work.
- Disconnect the other components in the pumping system from the electrical supply so that they cannot be operated accidentally.
- Do not reuse 'O' rings and Co-Seals if they are damaged.

### 3.2 System requirements

Consider the following points when you design your pumping system:

- Support the vacuum pipelines to stop the transmission of stress to the pipeline joints.
- You must be able to isolate the pump inlet and outlet from the atmosphere and from your vacuum system if you have pumped dangerous gases.

### 3.3 Unpack and inspect

1. Place the carton in a convenient position with a fork-lift truck or a pallet truck.
2. Remove all packing materials.
3. If the pump is an ESDP12, use the lifting-handle (Figure 1, item 4) to lift the pump from its carton. If the pump is an ESDP30, attach suitable lifting-gear to the lifting eye (Figure 2, item 4) and remove the pump from its carton; do not try to lift the pump by hand.
4. Remove all protective covers and inspect the pump. If the pump is damaged, notify your supplier and the carrier in writing within three days; state the Item Number of the pump together with your order number and your supplier's invoice number. Retain all packing materials for inspection. Do not use the pump if it is damaged.
5. If the pump is not to be used immediately, replace the protective covers. Store the pump in suitable conditions as described in Section 6.1.

### 3.4 Reconfigure the ESDP30 pump (optional)

The ESDP30 pump is supplied with the inlet and outlet-flanges at the side of the pump (as shown in Figure 2) to prevent blockage of the pump-inlet or outlet by the process gases pumped. If you will only use the pump on a clean and dry process, you can move the inlet and outlet-flanges to the top of the pump; refer to Figure 2 and use the following procedure:

1. Lift the pump into a vertical position so that it rests on the motor end-cover (15).
2. Undo and remove the four bolts which secure the fan cover (1) to the body of the pump. Remove the fan cover.
3. Undo and remove the six bolts (9) which secure the body of the pump to the motor.
4. Lift the body of the pump clear of the motor. If you cannot lift the body of the pump off of the motor, place two of the bolts removed in Step 3 in the jacking holes (11), then tighten the bolts to push the body of the pump away from the motor.
5. Turn the body of the pump through 90°, so that the inlet and outlet-flanges are at the top of the pump (that is, opposite the base-plate).
6. Ensure that the flexible coupling and the two locating dowels (8) are correctly aligned, then lower the body of the pump back onto the motor shaft.
7. Turn the cooling-fan and check that the pump mechanism rotates smoothly. If you cannot turn the fan easily, the body of the pump is not correctly aligned on the motor.
8. Use the six bolts removed in Step 3 to secure the body of the pump to the motor.
9. Use the four bolts removed in Step 2 to secure the fan cover to the body of the pump.
10. Turn the pump over so that it rests on the base-plate (13).



### 3.5 Locate the pump

---

**CAUTION**

Locate the pump so that it is on a firm, level surface (less than 5° inclination). If you do not, seals in the pump may wear quickly and the performance of the pump will deteriorate.

---



---

**CAUTION**

Do not operate the pump in direct sunlight. If you do, the pump may overheat and fail.

---

Ensure that the pump is not installed in an enclosed area. The ESDP12 pump requires a cooling-air flow rate of 4 m<sup>3</sup>min<sup>-1</sup>; the ESDP30 pump requires a cooling-air flow rate of 5 m<sup>3</sup>min<sup>-1</sup>. The cooling-fans will provide this flow rate if the pump is not installed in a restricted space.

To locate the ESDP12 pump:

- Refer to [Figure 1](#).
- Use the lifting-handle (4) to lift the pump and move it into its final operating position. The pump can be free-standing or you can use fixing-bolts through the mounting-holes (9) in the base-plate of the pump to secure the pump to the floor.

To locate the ESDP30 pump:

- Refer to [Figure 2](#).
- Attach suitable lifting gear to the lifting-eye (4) on the pump and move the pump to its final operating position. The pump can be free-standing or you can use fixing-bolts through the mounting-holes (14) in the base-plate of the pump to secure the pump to the floor.

If you want, you can fit vibration isolators below the base-plate. Suitable vibration isolators are available as optional accessories (see [Section 7](#)).

## 3.6 Connect the electrical supply

---

### *CAUTION*

The motor is not thermally protected. You must provide external overload protection. Branch circuit fuses must have a maximum rating of 115% of the full load current rating given in [Section 2](#).

---

#### 3.6.1 Introduction

Connect the electrical supply to the motor as described in [Section 3.6.2](#), [3.6.3](#) or [3.6.4](#). Connect the supply through a contactor which incorporates a circuit breaker suitable for the full load current ratings given in [Section 2](#).

#### 3.6.2 Connect to ESDP12 pumps

1. Refer to [Figure 1](#). Undo and remove the screws which secure the cover to the motor terminal-box (6), then remove the cover.
2. Refer to [Figure 9](#). Check your electrical supply voltage and frequency. The universal motor of the pump can be configured for 'high-voltage' operation (200-230 V), as shown in detail A, or for 'low-voltage' operation (100-115 V) as shown in detail B. The pump is supplied configured for 'high-voltage' operation. If necessary, reconfigure the links (1) in the terminal-box to operate with your supply voltage.
3. Fit a suitable 20 mm cable-gland to the cable leadthrough hole. If your cable is too large to pass through a 20 mm cable-gland, fit a 20 mm to 25 mm female thread adaptor to the cable entry-hole, and fit a 20 mm cable-gland to the adaptor.
4. Pass the electrical supply cable through the cable-gland.
5. Connect the neutral and live wires in the cable (N, L) to the terminals as shown in detail A or B, depending on your electrical supply voltage, then connect the earth (ground) wire in the cable to the earth (ground) stud in the terminal-box.
6. Tighten the cable-gland.
7. Connect the wires at the other end of the cable to your electrical supply.
8. Refer to [Figure 1](#). Refit the cover to the motor terminal-box (6) and secure with the screws removed in Step 1.

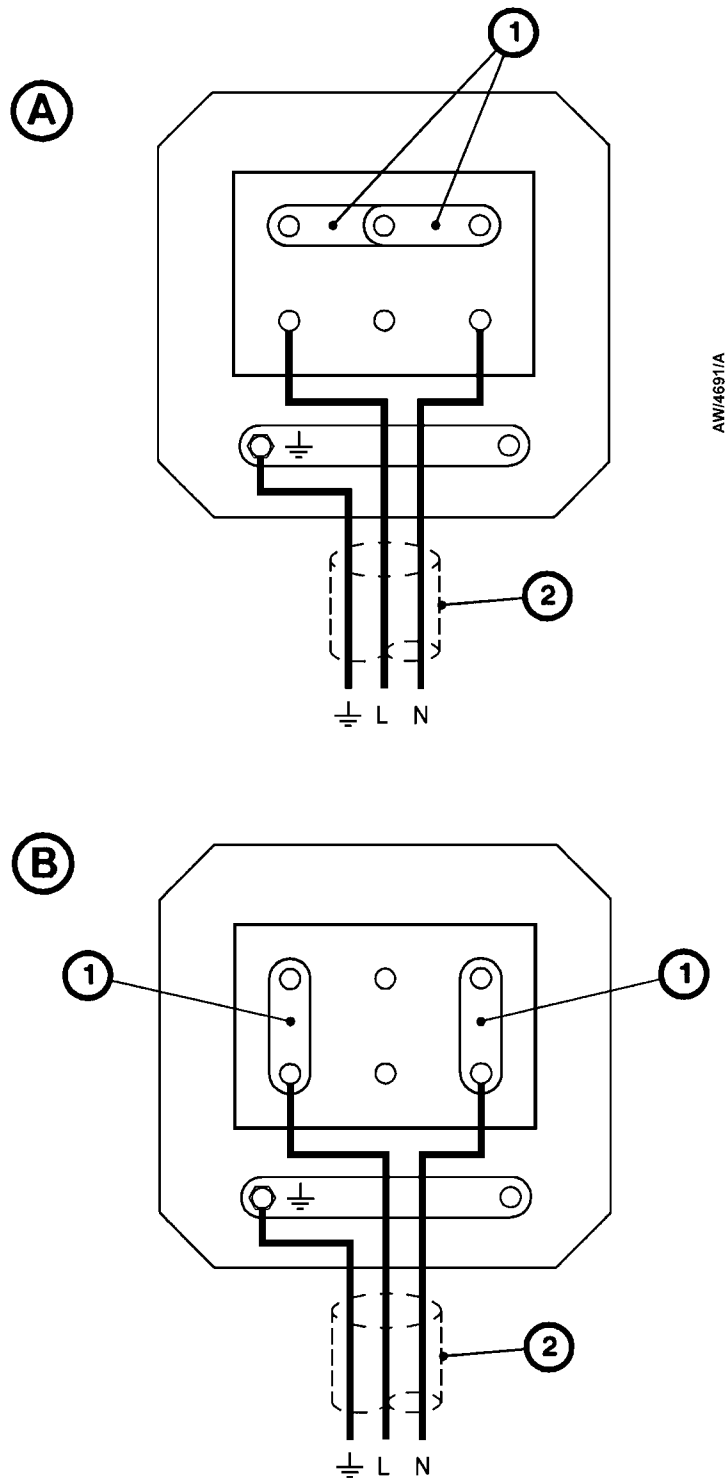
### 3.6.3 Connect to ESDP30 3-phase pumps

1. Refer to [Figure 2](#). Undo and remove the screws which secure the cover to the motor terminal-box (5), then remove the cover.
2. Check your electrical supply voltage and frequency. The universal motor of the pump can be configured for 'low-voltage' operation (200-230 V) as shown in [Figure 10](#), or for 'high-voltage' operation (380-460 V), as shown in [Figure 11](#). If necessary, reconfigure the motor to operate with your supply voltage.
3. Fit a suitable 20 mm cable-gland to the cable leadthrough hole. If your cable is too large to pass through a 20 mm cable-gland, fit a 20 mm to 25 mm female thread adaptor to the cable entry-hole, and fit a 20 mm cable-gland to the adaptor.
4. Pass the electrical supply cable through the cable-gland.
5. Connect the phase wires in the cable (L1, L2, L3) to the U, V and W terminals as shown in [Figures 10 or 11](#), depending on your electrical supply voltage, then connect the earth (ground) wire in the cable to the earth (ground) stud in the terminal-box.
6. Tighten the cable-gland and replace the terminal-box cover.
7. Connect the wires at the other end of the cable to your electrical supply.
8. Refer to [Figure 2](#). Refit the cover to the motor terminal-box (5) and secure with the screws removed in Step 1.

### 3.6.4 Connect to ESDP30 1-phase pumps

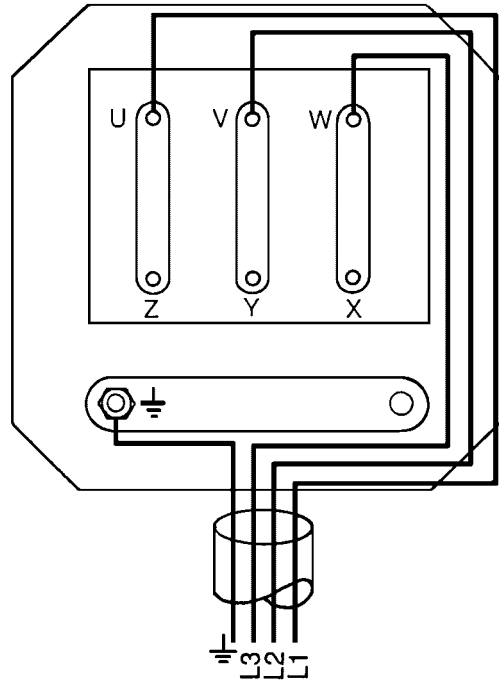
1. Refer to [Figure 2](#). Undo and remove the screws which secure the cover to the motor terminal-box (5), then remove the cover.
2. Check your electrical supply voltage and frequency. The universal motor of the pump can be configured for 'low-voltage' operation (100-115 V) as shown in [Figure 12](#), or for 'high-voltage' operation (200-230 V), as shown in [Figure 13](#). If necessary, reconfigure the motor to operate with your supply voltage.
3. Fit a suitable 20 mm cable-gland to the cable leadthrough hole. If your cable is too large to pass through a 20 mm cable-gland, fit a 20 mm to 25 mm female thread adaptor to the cable entry-hole, and fit a 20 mm cable-gland to the adaptor.
4. Pass the electrical supply cable through the cable-gland.
5. Connect the neutral and live wires in the cable (N, L) to the X and Z terminals as shown in [Figures 12 or 13](#), depending on your electrical supply voltage, then connect the earth (ground) wire in the cable to the earth (ground) stud in the terminal-box.
6. Tighten the cable-gland.
7. Connect the wires at the other end of the cable to your electrical supply.
8. Refer to [Figure 2](#). Refit the cover to the motor terminal-box (5) and secure with the screws removed in Step 1.

Figure 9 - ESDP12 motor terminal-box



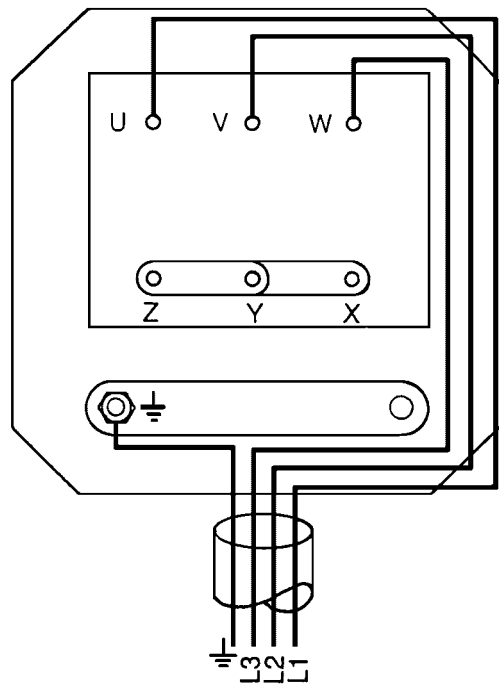
- A. High-voltage configuration
- B. Low-voltage configuration
- 1. Links
- 2. Electrical supply cable

Figure 10 - ESDP30 motor terminal-box low-voltage configuration: 3-phase pumps



AG/0437/B

Figure 11 - ESDP30 motor terminal-box high-voltage configuration: 3-phase pumps



AG/0436/B

Figure 12 - ESDP30 motor terminal-box low-voltage configuration: 1-phase pumps

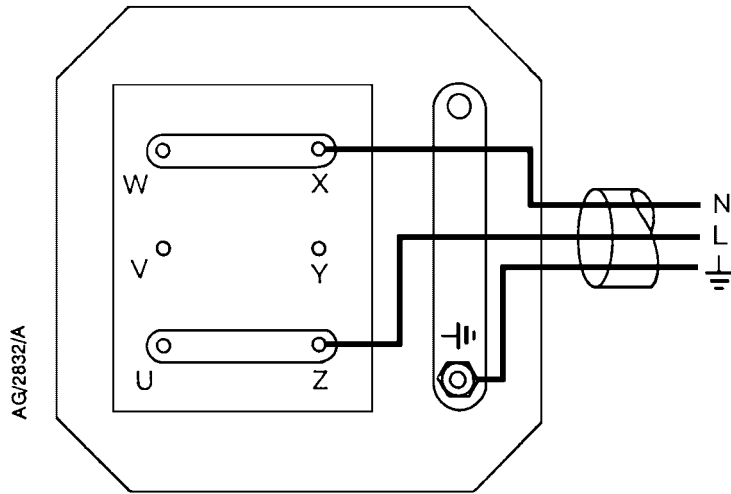
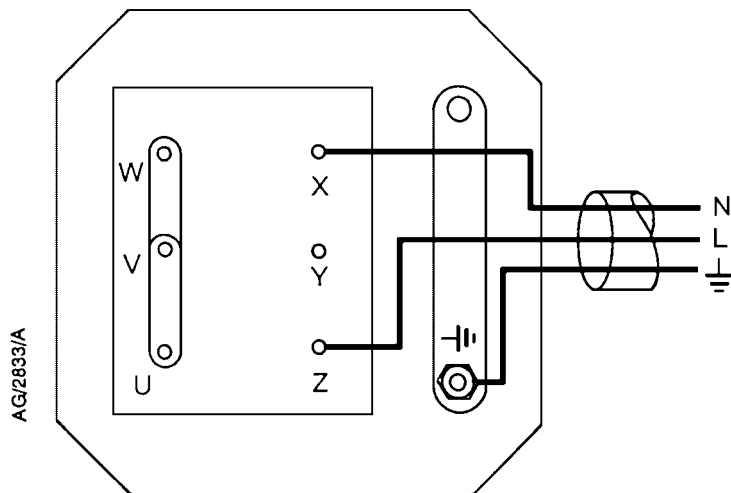


Figure 13 - ESDP30 motor terminal-box high-voltage configuration: 1-phase pumps



### 3.7 Check the direction of motor rotation

---

#### CAUTION

Ensure that debris and objects do not fall into the pump inlet when you check the direction of motor rotation. If this happens, you may damage the pump.

---

*Note:* When you switch off the pump, the cooling-fan may stop and then rotate in the reverse direction for a few revolutions.

1. Watch the cooling-fan from the motor end of the pump, switch on the pump for two or three seconds, then switch the pump off.
2. The correct direction of rotation of the cooling-fan is clockwise when viewed from the motor end of the pump and is indicated by the arrow on the coupling-cover (Figure 1, item 3 for the ESDP12 and Figure 2, item 7 for the ESDP30). If the direction of rotation is incorrect:
  - On an ESDP30 3-phase pump, isolate the pump from the electrical supply, swap any two of the phase-wires in the motor terminal-box, then reconnect the pump to the electrical supply and repeat step 1 to ensure that the direction of rotation is now correct.
  - On ESDP12 and ESDP30 1-phase pumps, do not use the pump; contact your supplier or Edwards for advice.

### 3.8 Connect the pump-inlet to the vacuum system

Ensure that debris does not get into the pump when you install it. If the pump is to replace a pump in an existing system, purge the existing pump with nitrogen for 15 minutes before you disconnect it. If the existing pump is an oil-sealed pump, we recommend that you dismantle the pipeline which connects the vacuum system to the pump and clean the pipeline to ensure that there is no residual oil contamination in the pipeline.

Use standard NW fittings to connect the pump-inlet to your vacuum system: refer to Section 2.1 for the inlet sizes. When you connect to the vacuum system:

- To get the best pumping speed, ensure that the pipeline connected to the pump-inlet has an internal diameter not less than the inlet-port diameter.
- Incorporate flexible bellows in your system pipelines to reduce the transmission of vibration and to prevent loading of coupling-joints. The bellows must have a maximum pressure rating which is greater than the highest pressure that can be generated in your system. We recommend that you use Edwards flexible bellows.
- Incorporate an inlet isolation-valve in the pipeline from the vacuum system to the pump, so that you can isolate the vacuum system from the pump when it is switched off and prevent the suck-back of process gases and debris into the vacuum system.

### 3.9 Connect the pump-outlet

We recommend that you use an exhaust extraction-system suitable for use with all of the process gases you will pump. Ensure that the exhaust-extraction system cannot become blocked or obstructed when the pump is operating.

Use standard NW fittings to connect the pump-outlet to the exhaust-extraction system: refer to [Section 2.1](#) for the outlet sizes.

Note that the ESDP12 pump is supplied with the flange face of the outlet ([Figure 1](#), item 10) towards the front of the pump. If required, you can turn the outlet through a maximum of 90° towards each side of the pump. If you want to reorientate the outlet, use the following procedure:

1. Refer to detail A. Loosen the locknut (13).
2. Turn the outlet (10) to the required orientation.
3. Tighten the locknut (13).

### 3.10 Leak test the pump installation

Leak test the pump installation and seal any leaks found to prevent the leakage of dangerous substances from the system and the leakage of air into the system. When supplied, the leak tightness of the pump is less than  $1 \times 10^{-4} \text{ mbar}\cdot\text{ls}^{-1}$  ( $1 \times 10^{-2} \text{ Pa}\cdot\text{ls}^{-1}$ ).



## 4 Operation

**Note:** *The following procedures assume that your system has an inlet isolation-valve which you can use to isolate the pump from your vacuum system.*

### 4.1 Start-up

Use the procedure below to start up the pump.

1. Ensure that the vacuum system isolation-valve is closed.
2. Switch on the electrical supply to the pump.
3. Open the vacuum system isolation-valve.

### 4.2 Shut-down

**Note:** *When you switch off the pump, the cooling-fan may stop and then rotate in the reverse direction for a few revolutions.*

Use the procedure below to shut down the pump.

1. Close the vacuum system isolation-valve (to prevent suck-back into the vacuum system).
2. Switch off the electrical supply to the pump.

## 5 Maintenance

**Note:** *You must maintain the pump as described in this section. If you do not, the pump performance may be poor or the pump may fail prematurely.*

### 5.1 Introduction

The ESDP12 and ESDP30 pumps are designed to require little user maintenance. Do the following checks when you maintain your vacuum system:

- Check that the vacuum connections are secure.
- Check that the electrical connections are secure and that the electrical cable is not damaged.
- Check that the cooling-fins on the pump are not obstructed or blocked.

### 5.2 Remove debris from the pump

We recommend that you operate the pump at atmospheric pressure for one minute twice a week, to remove any debris that may have accumulated in the pump.

### 5.3 Inspect the inlet screen

Whenever you disconnect the pump from your vacuum system, we recommend that you:

- Remove any debris trapped by the inlet screen (in the inlet-port).
- Inspect the inlet screen and if necessary, clean it with a cleaning solution suitable for the substances pumped. To remove the inlet screen, remove the circlip which secures the inlet screen in the inlet-port. Refit the inlet screen in the inlet-port and secure with the circlip before you reconnect the pump to your vacuum system.

### 5.4 Service the pump

**Note:** *The service interval stated below assumes that the average ambient operating temperature of the pump is 25°C. Halve the interval between services for every increase in average ambient operating temperature of 10°C. For further advice please consult an Edwards service centre.*

We recommend that the ESDP12 and ESDP30 pumps are serviced by Edwards service engineers at least once a year (if the pumps are in continuous use) or every 8500 hours of pump operation; contact your supplier or Edwards to arrange these services.

## 6 Storage and disposal

### 6.1 Storage

Use the procedure below to store the pump.

1. Shut-down the pump as described in [Section 4](#).
2. Isolate the pump from the electrical supply and disconnect it from the vacuum system.
3. Place protective covers over the inlet and outlet-flanges.
4. Store the pump in cool, dry conditions until required for use. When required, prepare and install the pump as described in [Section 3](#).

### 6.2 Disposal

Dispose of the pump and any components safely in accordance with all local and national safety and environmental requirements. Take particular care with components which have been contaminated with dangerous process substances.

## 7 Spares and accessories

### 7.1 Introduction

Edwards products, spares and accessories are available from Edwards companies in Belgium, Brazil, Canada, France, Germany, Hong Kong, Italy, Japan, Korea, Switzerland, United Kingdom, U.S.A and a worldwide network of distributors. The majority of these centres employ Service Engineers who have undergone comprehensive Edwards training courses.

Order spare parts and accessories from your nearest Edwards company or distributor. When you order, state for each part required:

- Model and Item Number of your equipment
- Serial number (shown on the rating plate)
- Item Number and description of part.

### 7.2 Accessories

Accessory	Item Number
Vibration isolators (pack of 4)	A248-01-404

## Return of Edwards Equipment - Procedure

### INTRODUCTION

Before returning your equipment, you must warn Edwards if substances you used (and produced) in the equipment can be hazardous. This information is fundamental to the safety of our Service Centre employees and will determine the procedures employed to service your equipment.

**Complete the Declaration (HS2) and send it to Edwards before you dispatch the equipment.** It is important to note that this declaration is for Edwards internal use only, and has no relationship to local, national or international transportation safety or environmental requirements. As the person offering the equipment for shipment, it is your responsibility to ensure compliance with applicable laws.

### GUIDELINES

- Equipment is '**uncontaminated**' if it has not been used, or if it has only been used with substances that are not hazardous. Your equipment is '**contaminated**' if it has been used with any substances classified as hazardous under EU Directive 67/548/EEC (as amended) or OSHA Occupational Safety (29 CFR 1910).
- If your equipment has been used with radioactive substances, biological or infectious agents, mercury, polychlorinated biphenyls (PCB's), dioxins or sodium azide, you must decontaminate it before you return it to Edwards. You must send independent proof of decontamination (for example a certificate of analysis) to Edwards with the Declaration (HS2). Phone Edwards for advice.
- If your equipment is contaminated, you must either:
  - Remove all traces of contamination (to the satisfaction of laws governing the transportation of dangerous/hazardous substances).
  - Or, properly classify the hazard, mark, manifest and ship the equipment in accordance with applicable laws governing the shipment of hazardous materials.

**Note: Some contaminated equipment may not be suitable for airfreight.**

### PROCEDURE

1. Contact Edwards and obtain a Return Authorisation Number for your equipment.
2. Complete the Return of Edwards Equipment - Declaration (HS2).
3. If the equipment is contaminated, you must contact your transporter to ensure that you properly classify the hazard, mark, manifest and ship the equipment, in accordance with applicable laws governing the shipment of contaminated/hazardous materials. As the person offering the equipment for shipment, it is your responsibility to ensure compliance with applicable law. **Note: Equipment contaminated with some hazardous materials, such as semiconductor by-products, may not be suitable for airfreight - contact your transporter for advice.**
4. Remove all traces of hazardous gases: pass an inert gas through the equipment and any accessories that will be returned to Edwards. Where possible, drain all fluids and lubricants from the equipment and its accessories.
5. Seal up all of the equipment's inlets and outlets (including those where accessories were attached) with blanking flanges or, for uncontaminated product, with heavy gauge tape.
6. Seal equipment in a thick polythene/polyethylene bag or sheet.
7. If the equipment is large, strap the equipment and its accessories to a wooden pallet. If the equipment is too small to be strapped to a pallet, pack it in a suitable strong box.
8. E-mail via scan, fax or post a copy of the original with signature of the Declaration (HS2) to Edwards. The Declaration must arrive before the equipment.
9. Give a copy of the Declaration (HS2) to the transporter. You must tell your transporter if the equipment is contaminated.
10. Seal the original Declaration in a suitable envelope: attach the envelope securely to the outside of the equipment package, in a clear weatherproof bag.  
**WRITE YOUR RETURN AUTHORISATION NUMBER CLEARLY ON THE OUTSIDE OF THE ENVELOPE OR ON THE OUTSIDE OF THE EQUIPMENT PACKAGE.**

## Return of Edwards Equipment - Declaration

Return Authorisation Number: \_\_\_\_\_

You must:

- Know about all of the substances which have been used and produced in the equipment before you complete this Declaration
- Read the Return of Edwards Equipment - Procedure (HS1) before you complete this Declaration
- Contact Edwards to obtain a Return Authorisation Number and to obtain advice if you have any questions
- Send this form to Edwards before you return your equipment as per the procedure in HS1

### SECTION 1: EQUIPMENT

Manufacturer's Product Name \_\_\_\_\_

Manufacturer's Part Number \_\_\_\_\_

Manufacturer's Serial Number \_\_\_\_\_

Has the equipment been used, tested or operated?

YES  Go to Section 2      NO  Go to Section 4

**IF APPLICABLE:**

Tool Reference Number \_\_\_\_\_

Process \_\_\_\_\_

Failure Date \_\_\_\_\_

Serial Number of Replacement Equipment \_\_\_\_\_

### SECTION 2: SUBSTANCES IN CONTACT WITH THE EQUIPMENT

Are any substances used or produced in the equipment:

- Radioactive, biological or infectious agents, mercury, poly chlorinated biphenyls (PCBs), dioxins or sodium azide? (if YES, see Note 1)      YES  NO
- Hazardous to human health and safety?      YES  NO

**Note 1:** Edwards will not accept delivery of any equipment that is contaminated with radioactive substances, biological/infectious agents, mercury, PCB's, dioxins or sodium azide, unless you:

- Decontaminate the equipment
- Provide proof of decontamination

**YOU MUST CONTACT EDWARDS FOR ADVICE BEFORE YOU RETURN SUCH EQUIPMENT**

### SECTION 3: LIST OF SUBSTANCES IN CONTACT WITH THE EQUIPMENT

Substance name	Chemical Symbol	Precautions required (for example, use protective gloves, etc.)	Action required after a spill, leak or exposure

### SECTION 4: RETURN INFORMATION

Reason for return and symptoms of malfunction: \_\_\_\_\_  
 \_\_\_\_\_

If you have a warranty claim:

- who did you buy the equipment from? \_\_\_\_\_
- give the supplier's invoice number \_\_\_\_\_

### SECTION 5: DECLARATION

Print your name: \_\_\_\_\_ Print your job title: \_\_\_\_\_

Print your organisation: \_\_\_\_\_

Print your address: \_\_\_\_\_  
 \_\_\_\_\_

Telephone number: \_\_\_\_\_ Date of equipment delivery: \_\_\_\_\_

I have made reasonable enquiry and I have supplied accurate information in this Declaration. I have not withheld any information, and I have followed the Return of Edwards Equipment - Procedure (HS1).

Signed: \_\_\_\_\_ Date: \_\_\_\_\_

**Note: Please print out this form, sign it and return the signed form as hard copy.**