

# Instruction Manual

## XDS Dry Pump



Description	Electrical Supply	Item Number
XDS100B Scroll Booster	100-120 V, 200-230 V, 50/60 Hz, Single Phase	A732-01-983

Chemtech Scientific provides access to this content as a courtesy.  
We do not own the content contained in this document.  
All rights and credit go directly to its rightful owners.  
[www.chemtechsci.com](http://www.chemtechsci.com)  
Call us at: 484-424-9415

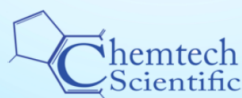

# Contents

Section	Page
<b>1 Introduction</b> .....	<b>1</b>
1.1 Scope of this manual .....	1
1.2 ATEX directive implication .....	2
1.3 Description .....	3
1.4 Gas ballast control .....	4
1.5 Construction .....	4
<b>2 Technical data</b> .....	<b>5</b>
2.1 Operating and storage conditions .....	5
2.2 Performance .....	5
2.2.1 General .....	5
2.2.2 Performance characteristics .....	6
2.3 Mechanical data .....	6
2.3.1 General .....	6
2.3.2 Vibration data .....	7
2.4 Electrical data .....	7
<b>3 Installation</b> .....	<b>9</b>
3.1 Safety .....	9
3.2 System design considerations .....	9
3.3 Unpack and inspect .....	11
3.4 Locate the pump .....	11
3.4.1 Mechanical fixing .....	11
3.5 Electrical installation .....	11
3.5.1 Check and configure the pump .....	11
3.5.2 Connect the pump to your electrical supply .....	12
3.6 Inlet and outlet connections .....	12
3.7 Leak test the system .....	13
<b>4 Operation</b> .....	<b>15</b>
4.1 Use of gas ballast control .....	15
4.2 Start up procedure .....	15
4.3 To achieve ultimate vacuum .....	15
4.4 To pump condensable vapours .....	15
4.5 Implication of ATEX directive .....	16
4.5.1 Introduction .....	16
4.5.2 Flammable/pyrophoric materials .....	16
4.5.3 Gas purges .....	16
4.6 Remote operation using 15 way D connector .....	17
4.7 Shut down .....	17
<b>5 Maintenance</b> .....	<b>19</b>
5.1 Safety information .....	19
5.2 Maintenance plan .....	20
5.3 Inspect and clean the inlet strainer .....	20
5.4 Clean the external fan cover .....	21
5.5 Replace the tip seals .....	21
5.6 Test the motor condition .....	21
5.7 Fault-finding .....	22
5.7.1 The pump has failed to start or has stopped .....	22

5.7.2	The pump has failed to achieve the required performance .....	22
5.7.3	The pump is noisy .....	22
5.7.4	The pump surface temperature is high .....	23
5.7.5	The pumping speed is poor or if pump down time is too long .....	23
<b>6</b>	<b>Storage and disposal .....</b>	<b>25</b>
6.1	Storage .....	25
6.2	Disposal .....	25
<b>7</b>	<b>Service, spares and accessories .....</b>	<b>27</b>
7.1	Introduction .....	27
7.2	Service .....	27
7.3	Accessories .....	27
7.3.1	Electrical cables .....	27
7.3.2	Silencer .....	27
7.3.3	Gas ballast adaptor .....	27
7.3.4	Solenoid operated pipeline valves .....	28
7.3.5	Tip seal and exhaust valve service kit .....	28

For return of equipment, complete the HS Forms at the end of this manual.

## Illustrations

Figure		Page
1	XDS100B scroll booster .....	3
2	Performance characteristics .....	6
3	Installation drawing .....	10
4	Logic interface schematic .....	18
5	Inlet strainer assembly .....	21

## Tables

Table		Page
1	Operating and storage conditions .....	5
2	CSA approval environmental conditions .....	5
3	General characteristics .....	5
4	General mechanical data .....	6
5	Vibration data .....	7
6	Electrical ratings for continuous operation .....	7
7	Recommended fuses .....	7
8	Pin status on the logic interface connector .....	18
9	Maintenance plan .....	20
10	Electrical cables .....	27
11	Solenoid operated pipeline valves .....	28

## Associated publications

### Publication title

Vacuum Pump and Vacuum System Safety

### Publication number

P300-20-000

# 1 Introduction

## 1.1 Scope of this manual

This manual provides installation, operation and maintenance instructions for the Edwards XDS100B Scroll Booster. You must use your pump as specified in this manual. Read this manual before you attempt to install and operate your pump.

Important safety information is highlighted as WARNING and CAUTION instructions; you must obey these instructions. The use of WARNINGS and CAUTIONS is defined below.



### **WARNING**

Warnings are given where failure to observe the instruction could result in injury or death to people.

### **CAUTION**

Cautions are given where failure to observe the instruction could result in damage to the equipment, associated equipment and process.

Pressures are stated as absolute pressures throughout this manual.

The following IEC warning labels appear on the pump:



Warning - refer to accompanying documentation.



Warning - risk of electric shock.



Warning - hot surfaces.

## 1.2 ATEX directive implication



This equipment is designed to meet the requirements of Group II Category 3 equipment in accordance with Directive 94/9/EC of the European Parliament and the Council of 23rd March 1994 on the approximation of the laws of the Member States concerning equipment and protective systems intended for use in potentially explosive atmospheres. (The ATEX Directive).

The ATEX Category 3 applies in respect of potential ignition sources internal to the equipment. An ATEX Category has not been assigned in respect of potential ignition sources on the outside of the equipment as the equipment has not been designed for use where there is an external potentially explosive atmosphere.

There is no potential source of ignition within the pump during normal operation but there may be potential sources of ignition under conditions of foreseeable and rare malfunction as defined in the Directive. Accordingly, although the pump is designed to pump flammable materials and mixtures, operating procedures should ensure that under all normal and reasonably foreseeable conditions, these materials and mixtures are not within explosive limits.

When flammable materials are present within the equipment you must:

- Not allow air to enter the equipment.
- Ensure the system is leak tight.

Further details can be obtained by contacting Edwards UK on +44 1293 528844.

Figure 1 - XDS100B scroll booster

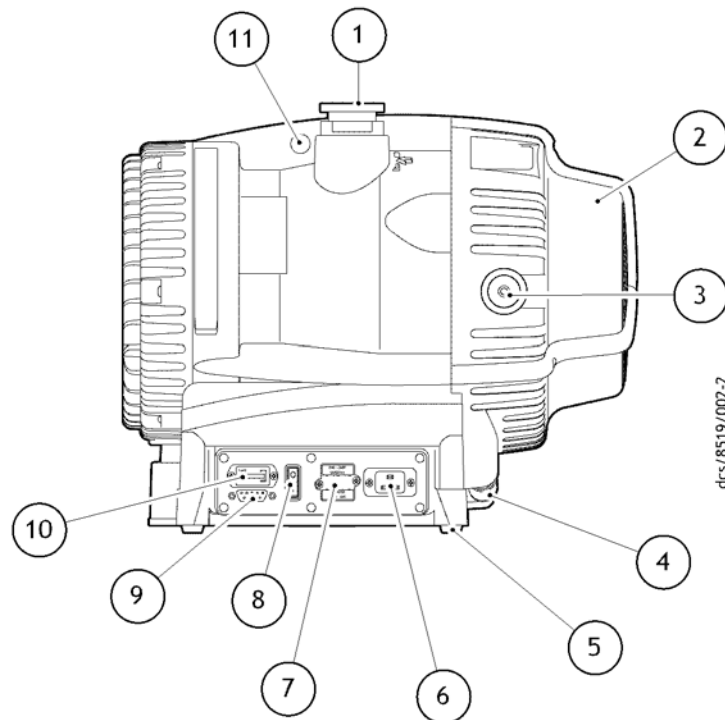

- |                         |                                    |
|-------------------------|------------------------------------|
| 1. NW40 inlet port      | 7. Voltage changeover switch cover |
| 2. Cooling fan          | 8. Run/Standby switch              |
| 3. NW40 exhaust port    | 9. 15 way connector                |
| 4. Fan connector        | 10. Hour counter                   |
| 5. Rubber feet          | 11. Lifting eye                    |
| 6. Electrical connector |                                    |

### 1.3 Description

The XDS100B Scroll Booster is shown in [Figure 1](#). Refer to [Figure 1](#) for item numbers in brackets in the following descriptions.

The XDS pump is a compact, reliable vacuum pump which is suitable for use on vapour handling processes. The XDS100B is a scroll booster, with a pumping mechanism designed specifically for high pumping speed. It cannot exhaust directly to atmosphere, and must be backed by a primary pump; it is intended for use in conjunction with Edwards XDS35i or XDS46i scroll pumps.

The body of the pump includes a fixed scroll and an orbiting scroll. The orbiting scroll is controlled by the electric motor through an eccentric cam on the motor drive shaft. The movement of the orbiting scroll, meshed with the fixed scroll, forms successive crescent shaped volumes in the pump. Gas that enters the pump through the inlet is compressed by the movement of the orbiting scroll and swept towards the centre of the fixed scroll. The compressed gas enters the exhaust port near the centre of the stationary scroll and is exhausted from the pump through the outlet, which must be connected to a primary pump.

The XDS is a truly dry vacuum pump, as all the bearings, with their hydrocarbon lubricant, are isolated from the vacuum space.

The pump mechanism is driven directly by a three phase electric motor. The motor is controlled by an inverter, which manages the supply of current to the motor in accordance with operating conditions, and allows the pump to be connected to a single phase supply. The voltage changeover switch, beneath the voltage changeover switch cover, (7) must be set to the correct position in accordance with the power supply being used, refer to [Section 3.5.2](#).

The XDS100B is a scroll booster, optimised for maximum pumping speed at inlet pressures between 1 mbar and 10 mbar (refer to Figure 2). The XDS100B is not suitable for prolonged operation at inlet pressures above 20 mbar, for pumpdown of large volumes, or for rapid cyclic duty. Such operation may cause the pump to become hot or the inverter to reduce the motor speed. The pump will speed up again after the load is reduced.

The pump is air-cooled by a fan (2) mounted at the opposite end to the motor. The fan will run on for one minute after the pump is switched off. The XDS100B incorporates a thermal protection device that will stop the motor in the event of thermal overload, such as high ambient temperature. The pump will restart after it has cooled down.

The pump is fitted with an hours counter (10), which indicates the total time that the pump has run.

## 1.4 Gas ballast control

The XDS100B booster does not have a gas ballast option; condensation is not likely to occur in the pump, as the normal operating pressure is too low.

## 1.5 Construction

The pump scrolls are made of anodised aluminium. The motor housing is aluminium. All surfaces of the pump which are exposed to the pumped gases are free from copper, zinc and cadmium.

Other materials of construction include fluorocarbon elastomer, nitrile, chemically resistant polymers, nickel and stainless steel.

The tip seal is a PTFE composite material.



## 2 Technical data

### 2.1 Operating and storage conditions

Table 1 - Operating and storage conditions

Operating and storage conditions	XDS100B
Ambient temperature range (operation)	+10 °C to +40 °C
Maximum surface temperature of pump body under normal operating conditions and maximum ambient temperature	+40 °C to +70 °C
Maximum humidity (operation)	90% RH
Ambient temperature range (storage)	-30 °C to +70 °C

Table 2 - CSA approval environmental conditions

Parameter	XDS100B
Pollution	Pollution degree 2
Installation	Installation category II
Altitude restriction	Max 2000 m
Area of use	Indoor use

### 2.2 Performance

#### 2.2.1 General

Table 3 - General characteristics

General	XDS100B
Nominal peak pumping speed	95 m <sup>3</sup> /h*
Maximum permitted continuous inlet pressure	20 mbar
Maximum permitted continuous exhaust pressure	60 mbar
Maximum permitted inlet pressure for short duration	1.5 bar(a)
Maximum chamber volume to pump down from atmospheric pressure	100 litres
Maximum chamber volume for cyclic duty - maximum 6 cycles per hour	50 litres
Suckback protection	Provided by backing pump
Leak tightness	<1x10 <sup>-6</sup> mbar l s <sup>-1</sup>

\* XDS100B used in combination with XDS35i backing pump.

**Note:** If the pump is operated outside the specified limits, then the inverter may reduce the motor speed; tip seal wear rate will be increased.

## 2.2.2 Performance characteristics

Figure 2 - Performance characteristics

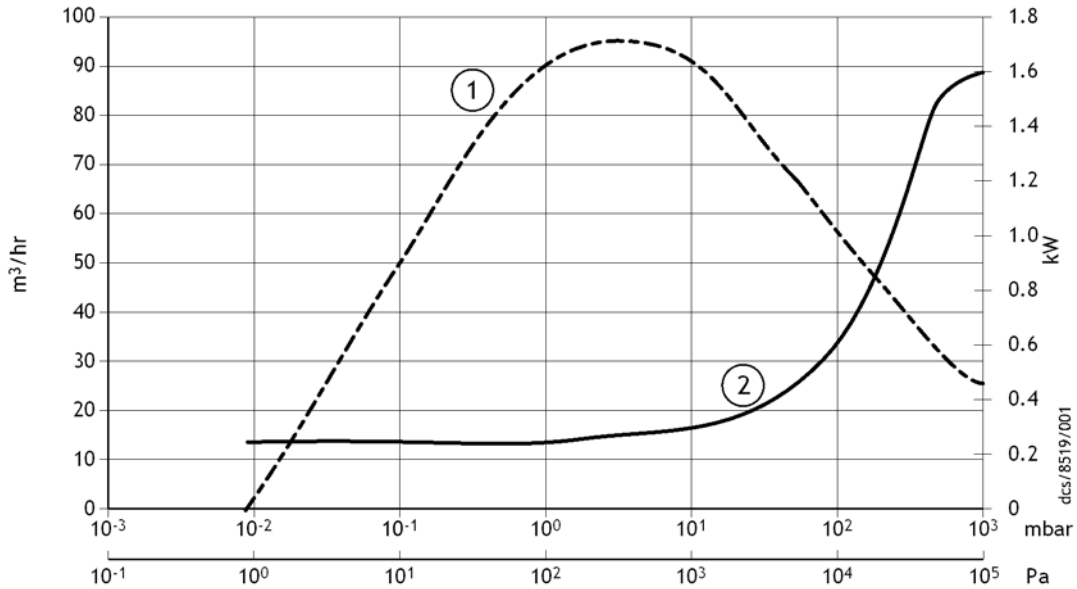

1. Speed      2. Power

**Note:** XDS100B is not suitable for prolonged operation at inlet pressures above 20 mbar. Under such conditions, the inverter may reduce the motor speed.

The above performance curve shows the XDS100B Scroll Booster speed and power consumption when used in conjunction with a XDS35i backing pump.

## 2.3 Mechanical data

### 2.3.1 General

Table 4 - General mechanical data

Parameter	XDS100B
Overall dimensions (L x W x H)	476 x 333 x 396 mm
Maximum tilt angle	10 degrees
Nominal rotational speed	1750 rpm
Mass	48 kg
Inlet connection	NW40
Outlet connection	NW40
Degree of protection (IEC60529)	IP44

### 2.3.2 Vibration data

Table 5 - Vibration data

Parameter	XDS100B
Sound pressure, measured at ultimate vacuum 1 metre from the end of the pump to ISO 3744 and ISO 4871	52.1 +/- 2.5 dB(A)
Vibration: measured at the inlet port (ISO 3744)	Class 1C...< 4.5 mms <sup>-1</sup> (rms)

## 2.4 Electrical data

Table 6 - Electrical ratings for continuous operation

Pump	Supply (V)	Phase	Frequency (Hz)	Current (A)
XDS100B	200/230	Single	50/60	6.6
	100/120	Single	50/60	10.6

Table 7 - Recommended fuses

Area	Voltage	Rating
UK	230 V	13 A
Europe	230 V	16 A
US	110 V	20 A
Japan	100 V	20 A

**Note:** Time-lag fuses should be used, as the initial inrush current can exceed rated values briefly when pump is started.

## 3 Installation

### 3.1 Safety



#### **WARNING**

Obey the safety instructions given below and take note of appropriate precautions. If you do not, you can cause injury to people and damage to equipment.



#### **WARNING**

Prevent any part of the human body coming into contact with the vacuum.



#### **WARNING**

The Edwards XDS100B booster is not recommended for pumping explosive gases or hazardous substances.

You must ensure that the XDS100B booster is suitable for your application. If you have any doubt about the suitability of the XDS100B booster for your application, refer to the Edwards guidelines on vacuum pump and vacuum system safety (see associated publications at the end of the contents list at the front of this manual).

A suitably trained and supervised technician must perform the installation of the XDS100B Booster. Obey the safety instructions listed below when you install the XDS pump, especially when you connect the pump into an existing system. Details of the specific safety precautions are given at the appropriate point in the instructions.

- Wear the appropriate safety clothing when you come into contact with contaminated components. Dismantle and clean contaminated components inside a fume cupboard.
- Vent and purge your vacuum system before you start installation work.
- Ensure that the installation technician is familiar with the safety procedures that relate to the products handled by the pumping system.
- Disconnect the other components in the pumping system from the electrical supply so that they cannot be operated accidentally.

### 3.2 System design considerations

Consider the following points when you design your pumping system:

Avoid high levels of heat input into the pump from the process gases, otherwise the pump may overheat, and cause the thermal overload device to open.

Make sure that the foreline from the booster to the backing pump and the exhaust pipeline from the backing pump outlet cannot become blocked. If you have an exhaust isolation valve, make sure that you cannot operate the pump with the valve closed. Refer to [Section 3.6](#).

Provide for a purge of inert gas when you shut down the pumping system, to dilute dangerous gases to safe concentrations.

Figure 3 - Installation drawing

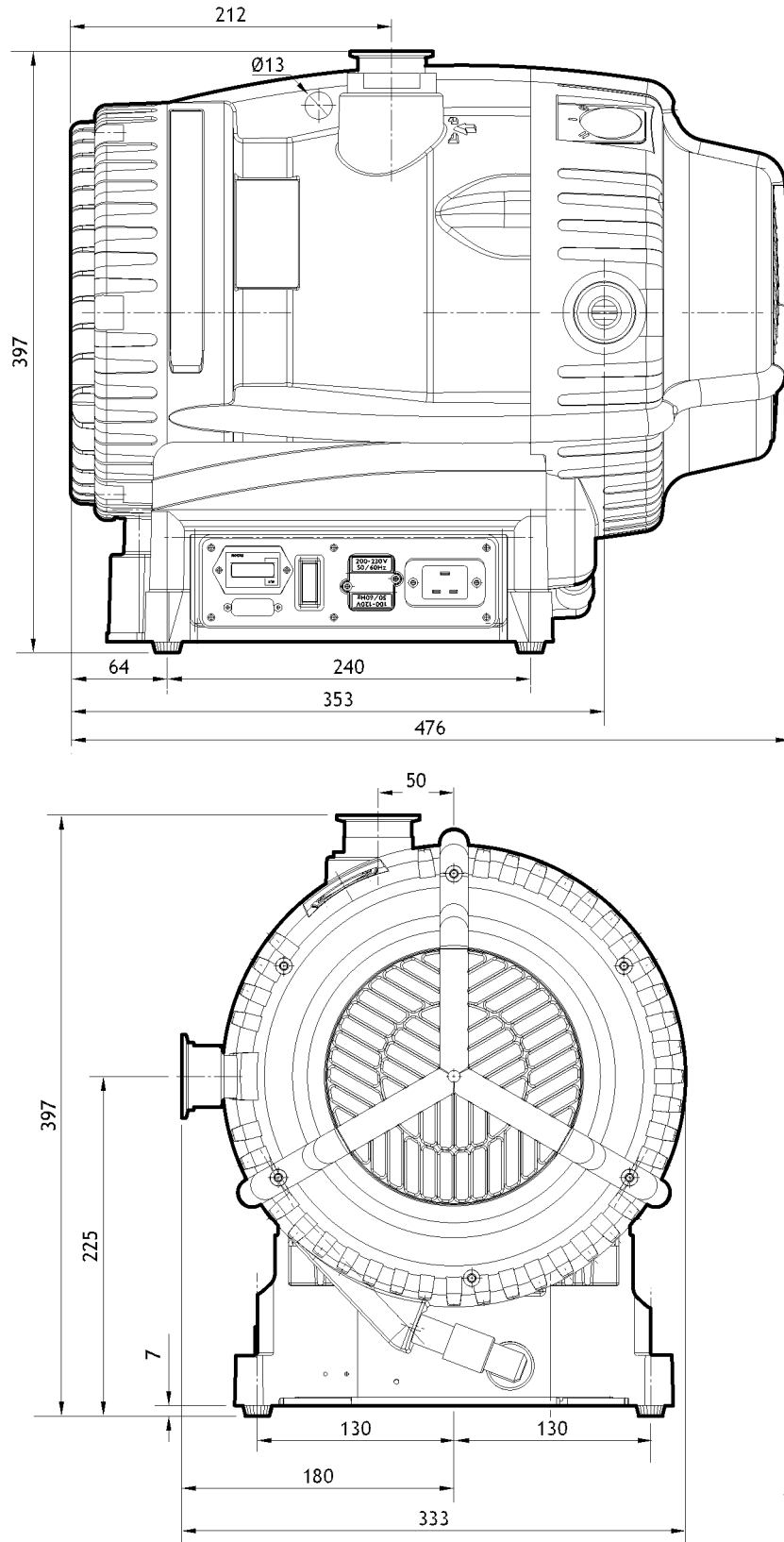

dc.s/8519/003

### 3.3 Unpack and inspect



#### WARNING

Use suitable lifting equipment to move the XDS100B booster. The mass of the pump is 48 kg.

- Mechanical lifting equipment should be attached to the lifting eye; loose slings should not be used.
- Take care when moving the pump into position. Its weight makes it difficult to slide. Movement should be attempted using two people.

Remove all packing materials, remove the pump from its packing box, remove the protective covers from the inlet and outlet ports and inspect the pump. If the pump is damaged, notify your supplier and the carrier in writing; state the item number of the pump together with your order number and your supplier's invoice number. Retain all the packing materials for inspection. Do not use the pump if it is damaged. If the pump is not to be used immediately, replace the protective covers. Store the pump in suitable conditions, as described in Section 6.1. Refer to Section 6.2 for disposal of materials.

### 3.4 Locate the pump



#### WARNING

If the pump is to be used on the floor of a work area, position the power lead and the exhaust and inlet hoses with care. Ensure that personnel in the area are aware of any obstructions around the pump.

Provide a firm, level platform for the pump. Locate the pump so that the Run/Standby switch is accessible.

If your pump will be located inside an enclosure, make sure that there is adequate ventilation at both ends of the pump, so that the ambient temperature around the pump does not exceed 40 °C. There must be a minimum space of 25 mm between the pump and the enclosure walls.

#### 3.4.1 Mechanical fixing

*Note:* If you wish to secure the pump you may do so using the four holes located on each corner of the pump base, we recommend you use M8 bolts.

### 3.5 Electrical installation

#### 3.5.1 Check and configure the pump

#### CAUTION

Before changing the voltage, unplug the power supply. Ensure that the pump is correctly configured for your electrical supply otherwise you may cause damage.

Ensure that the voltage shown on the voltage indicator (refer to Figure 1, item 7) on the motor cover corresponds with your electrical supply voltage. If it does not, you must change the configuration of the pump motor to match your supply voltage; use the procedure below.

1. Undo the two screws and lift off the voltage indicator moulding.
2. Rotate the voltage indicator moulding so that the correct voltage is uppermost.
3. Replace the two screws.

### 3.5.2 Connect the pump to your electrical supply



#### **WARNING**

Ensure that the electrical installation of the XDS pump conforms with your local and national safety requirements. It must be connected to a suitably fused and protected electrical supply with a suitable earth point.

Make the electrical connections to the pump motor with an IEC60320 cable socket (C19) that satisfies your local electrical standards. To ensure CSA/UL compliance a suitable approved mains supply cord must be used; refer to Table 10 for parts available from Edwards.

For recommended fuse ratings, refer to Table 7 in Section 2.4.

#### **CAUTION**

If using an overload circuit breaker it must be of a time lag type because of the high start up current.

#### **CAUTION**

If using an earth leakage device e.g. an RCD, use at least a 30 mA rated unit to avoid trip during start up.

The pump will automatically restart after restoration of the power supply following power failure.

## 3.6 Inlet and outlet connections



#### **WARNING**

If pumping dangerous gases or vapours, connect the exhaust of the backing pump to a suitable treatment plant to prevent the discharge of dangerous gases and vapours to the surrounding atmosphere.



#### **WARNING**

If the booster or backing pump is operated with the foreline or backing pump exhaust line blocked, high pressures may be generated in the pipework.

#### **CAUTION**

The XDS100B cannot exhaust directly to atmosphere and must be backed by a suitable primary pump.

Refer to Figure 1. Before you connect the pump to your vacuum system, remove the plastic cap from the inlet and the exhaust, and ensure that the inlet strainer is fitted to the pump inlet port. Use appropriate NW40 vacuum fittings for connection to your system.

Take note of the following information when you connect the pump to your vacuum system.

- To minimise noise and exhaust emissions, it is recommended that the primary pump backing the XDS100B is connected to an exhaust line or a silencer (refer to [Section 7.3.2](#)).
- For optimum pumping speeds, ensure that the pipeline connected to the pump inlet is as short as possible and has a suitable internal diameter. Also ensure a suitable backing pump is used, such as the XDS35i or XDS46i, and the connection between booster and backing pump is as short as possible with a suitable internal diameter.
- Support the vacuum pipeline to prevent loading of the coupling joints. If necessary, incorporate flexible bellows in your system pipelines to reduce the transmission of vibration and to prevent loading of the coupling joints.
- If the booster and its backing pump are operated with the exhaust line blocked, a pressure of 5.5 bar(a) may be generated in the exhaust pipework. Foreline pressure may reach 1.45 bar(a). Connect the pump using appropriate pipework and fittings.
- Incorporate an inlet isolation valve in the pipeline from the vacuum system to the booster pump and to the primary pump. These will enable the vacuum system, so that you can isolate the vacuum system from the pump when it is switched off and prevent the suckback of process gases and debris into the vacuum system.
- Ensure that the sealing surfaces are clean and scratch-free.

We recommend that you use an exhaust extraction system suitable for use with all of the process gases you will pump. Ensure that the exhaust extraction system cannot become blocked or obstructed when the pump is operating.

### 3.7 Leak test the system

After you have installed the XDS pump, leak test the system and seal any leaks found.



## 4 Operation

### 4.1 Use of gas ballast control

The XDS100B booster does not have a gas ballast option; condensation is not likely to occur in the pump, as the normal operating pressure is too low.

### 4.2 Start up procedure



#### **WARNING**

Ensure that your system design does not allow the exhaust pipeline to become blocked.

#### **CAUTION**

A fine dust may be emitted from the exhaust of the scroll pump during start up, particularly when the pump is new or if new tip seals are fitted. Refer to [Section 5.5](#) for further information when fitting new tip seals.

To pump down large volumes from atmospheric pressure, the backing pump should be started first, and the booster should be started only when system pressure has fallen to 100 mbar. For small volumes (<15 litres), it is acceptable to start both pumps simultaneously.

Use the procedure below to start up the pump:

1. Ensure that any vacuum system isolation valve is closed (if fitted).
2. Connect a suitable lead from the power supply to the electrical socket at the side of the pump.
3. Switch on the electrical supply to the pump, using the Run/Standby switch on the motor.
4. With manual operation always use the Run/Standby switch to start and stop the pump. If remote operation is used to control the pump, refer to [Section 4.6](#).
5. Open the vacuum system isolation valve (if fitted).

### 4.3 To achieve ultimate vacuum

In order to achieve the best possible vacuum the primary pump backing the booster should be operated without the gas ballast. If atmospheric moisture is present run the backing pump with the gas ballast control for 20 minutes before removal of the gas ballast.

### 4.4 To pump condensable vapours

Due to the low pressures throughout the XDS100B mechanism condensation is not likely within the booster pump. Please refer to the instruction manual of the booster backing pump for recommendations of gas ballast configuration for vapour handling.

## 4.5 Implication of ATEX directive

### 4.5.1 Introduction

This equipment is designed to meet the requirements of Group II Category 3 equipment in accordance with Directive 94/9/EC of the European Parliament and the Council of 23rd March 1994 on the approximation of the laws of the Member States concerning equipment and protective systems intended for use in potentially explosive atmospheres. (The ATEX Directive).

The ATEX Category 3 applies in respect of potential ignition sources internal to the equipment. An ATEX Category has not been assigned in respect of potential ignition sources on the outside of the equipment as the equipment has not been designed for use where there is an external potentially explosive atmosphere.

There is no potential source of ignition within the pump during normal operation but there may be potential sources of ignition under conditions of foreseeable and rare malfunction as defined in the Directive. Accordingly, although the pump is designed to pump flammable materials and mixtures, operating procedures should ensure that under all normal and reasonably foreseeable conditions, these materials and mixtures are not within explosive limits.

### 4.5.2 Flammable/pyrophoric materials

When flammable or pyrophoric materials are present within the equipment you must:

- Not allow air to enter the equipment.
- Ensure the system is leak tight.
- Dilute and flammable gases or vapours by using an inert purge (such as N<sub>2</sub>) to the pump inlet and or gas purge of the primary pump backing the XDS100B. Concentration levels of the gas or vapour within the pumps and exhaust lines should be reduced to less than one quarter of their published lower limits (LEL).

### 4.5.3 Gas purges

---

#### **CAUTION**

The following actions must be taken to ensure that the gas being pumped stays out of the flammable range.

---

The inert gas purge into the pump inlet or gas purge of the primary pump backing the XDS100B should be switched on to remove air from the pump and exhaust before the process starts. The purge flow can be switched off at the end of the process only after any remaining flammable gases or vapours have been purged from the pump and exhaust line.

If liquids that produce flammable vapours could be present in the pump foreline then the inert gas purge to the XDS100B should be left on all the time this liquid is present. Flammable liquids could be present in the foreline as a result of condensation or may be carried over from the process.

When calculating the flow rate of inert gas required for dilution, consider the maximum flow rate for the flammable gases/vapours that could occur. For example, if a mass flow controller is being used to supply flammable gases to the process, you should assume a flow rate for flammable gases that could arise if the mass flow controller is fully open. The inert gas purge flow rate should be continually measured and if the flow rate falls below that required, then the flow of flammable gases or vapours to the pump must be stopped.



#### **WARNING**

If you use a purge to dilute dangerous gases to a safe level, ensure that the system shuts down if the purge gas supply fails.

---

We recommend you obtain and read Vacuum Pump and Vacuum System Safety publication no P300-20-000 available from Edwards or your supplier.

## 4.6 Remote operation using 15 way D connector

It is possible to operate the pump remotely using the 15 way D type connector fitted on the panel at the side of the pump. (Refer to [Figure 1](#)).

The 15 way D connector is insulated to ensure that it remains protected in the event of a single fault condition.

The controls available are as follows:

- Run/Standby
- Boost (Run pump at 116%)
- Idle (Run pump at 67%)
- Run (Runs pump at standard speed 100%)
- OK Signal

[Figure 4](#) shows which connections to make to enable these functions.

The Run/Standby switch ([Figure 1](#), item 8) should be in the Standby position for remote operation.

To completely remove electrical power from the pump, the plug should be removed from the electrical connector ([Figure 1](#), item 6).

**Note:** *Boost operation is not recommended for the XDS100B as a permanent operation mode, as increased bearing loads will reduce the life of the pump bearings. Please consult Edwards if the boost mode is intended to be used.*

## 4.7 Shut down

Use the procedure below to shut down the pump:

1. If shutting the pump down prior to a period of storage, remove any process gases by running on high flow gas-ballast for at least one hour.
2. To prevent operation with excessive backing pressures it is recommended that the XDS100B is switched off before the booster backing pump is turned off.
3. Close any vacuum system isolation valve to prevent suckback into the vacuum system (where fitted).
4. Switch off the pump. When the pump is switched off the fan will continue to run for 1 minute.
5. Once the XDS100B has stopped the backing pump can be turned off.
6. Vent the XDS100B by the gas ballast control on its backing pump or via the valve on the inlet.

Figure 4 - Logic interface schematic

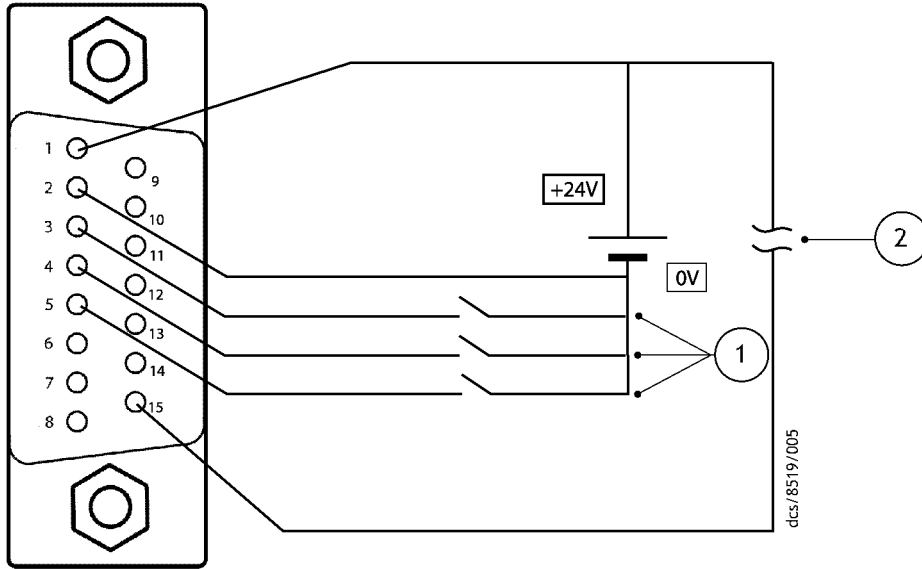

1. Speed control pins 3, 4 and 5  
Maximum current per pin = 7 mA when linked to pin 1 (24 V)
2. Pump healthy signal  
Signal high = normal (maximum permissible current = 100 mA)

Table 8 - Pin status on the logic interface connector

Mode	Speed percentage	Pin 1	Pin 3	Pin 4	Pin 5
Normal	100%	24 V	Link	open	open
Boost	116%	24 V	Link	Link	Link
Idle	67%	24 V	Link	Link	open

*Note: The tolerance of the power supply can be  $\pm 10\%$ . Make sure all the unused pins are not connected.*

## 5 Maintenance

### 5.1 Safety information



#### **WARNING**

Obey the safety instructions given below and take note of appropriate precautions. If you do not, you can cause injury to people and damage to equipment.

The XDS100B Scroll Booster is designed to require little user maintenance. Observe the following guidelines when carrying out maintenance on your pump:

- Ensure that maintenance is done by a suitably trained and supervised technician. Obey your local and national safety requirements.
- Ensure that the maintenance technician is familiar with the safety procedures which relate to the products processed by the pumping system.
- Check that all the required parts are available and are of the correct type before you start work. Refer to [Section 7.3.5](#).
- Allow the pump to cool before you start maintenance work.
- Do not re-use internal O-rings.



#### **WARNING**

Disconnect the pump and other components from the electrical supply so that they cannot be operated accidentally. Wait one minute for capacitor discharge after disconnecting the power supply before working on the pump.



#### **WARNING**

The XDS100B must be isolated from its backing pump before maintenance can begin. If the booster backing pump is connected and operational the XDS100B scrolls will rotate.



#### **WARNING**

The pump may be contaminated with the process chemicals that have been pumped during operation. If so, ensure that the pump is decontaminated before maintenance and that you take adequate precautions to protect people from the effects of dangerous substances if contamination has occurred.



#### **WARNING**

Do not touch or inhale the thermal breakdown products of fluorinated materials which may be present in the pump if the pump has been heated to 260 °C and above. Fluorinated materials are safe in normal use but can decompose into very dangerous substances (which may include hydrofluoric acid) if they are heated to 260 °C and above. The pump may have overheated if it was misused or if it was in a fire. Health and Safety Data sheets for fluorinated materials used in the pump are available on request; contact your supplier or Edwards.

## 5.2 Maintenance plan

More frequent maintenance may be required if the pump is used to pump aggressive gases and vapours, such as solvents, organic substances and acids, or if the pump is operated continuously at the higher end of its operating temperature range.

Table 9 - Maintenance plan

Operation	Frequency	Refer to Section
Inspect and clean inlet strainer	Annually	5.3
Clean the external fan cover	Annually	5.4
Replace the tip seal	Annually or as required	5.5
Test the motor / drive condition	15000 hours	5.6
Replace the bearings	35000 hours	Refer to Edwards

## 5.3 Inspect and clean the inlet strainer

Whenever you disconnect the pump from your vacuum system, we recommend that you:

- Remove any debris trapped by the inlet strainer (in the inlet port).
  - Inspect the inlet strainer and if necessary, clean it with a cleaning solution suitable for the substances pumped. Refit the inlet strainer before you reconnect the pump to your vacuum system.
1. Refer to [Figure 5](#). Disconnect your vacuum system from the pump inlet-port (3) and remove the centring-ring and strainer assembly (1) and the O-ring (2). Inspect the centring-ring and the O-ring. If they are clean, continue at Step 5. If they are not clean, continue at Step 2.
  2. Remove the O-ring (2) from the centring-ring and strainer assembly (1). Do not allow the O-ring to come into contact with the cleaning solution.
  3. Wash the centring-ring and strainer assembly in a suitable cleaning solution and allow it to dry.
  4. If necessary, wipe the O-ring with a clean, dry, lint-free cloth.
  5. Refit the centring-ring and strainer assembly and the O-ring to the inlet-port. Refit your vacuum system to the pump inlet-port.

Figure 5 - Inlet strainer assembly

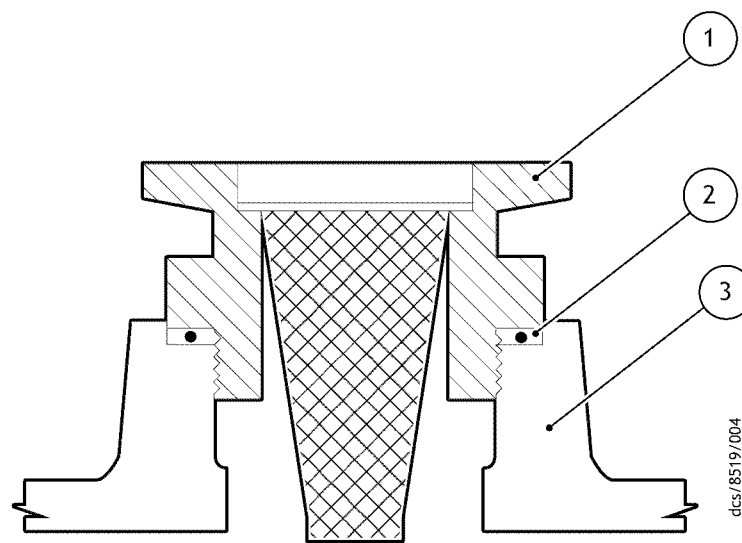

1. Centring ring and strainer
2. O-ring
3. Pump inlet-port

## 5.4 Clean the external fan cover

If the fan cover is not kept clean, the air flow over the pump can be restricted and the pump may overheat.

1. Switch off the pump and disconnect it from the electrical supply.
2. Use a dry cloth and a soft brush to remove dirt and deposits from the fan cover.

## 5.5 Replace the tip seals

This instruction is applicable to the XDS100B replacement tip seal kit (contained in minor service kit, refer to Section 7.3.5) that must be fitted.

## 5.6 Test the motor condition

---

### *CAUTION*

Do not flash test the XDS100B or damage to the inverter may result.

---

Test the earth continuity and the insulation resistance of the pump motor, in accordance with local regulations for the periodic testing of electrical equipment.

We recommend that the earth continuity is less than  $0.1\Omega$  and the insulation resistance is greater than  $2M\Omega$ . (Reference EN61010-1).

If the pump fails these tests, you must contact Edwards.

## 5.7 Fault-finding

### 5.7.1 The pump has failed to start or has stopped

- The electrical supply fuse has blown.
- The electrical supply voltage does not match that for which the inverter input has been configured.
- The inverter drive has not reset after an over temperature event. Disconnect the mains supply and wait for at least one minute and attempt to restart.
- The motor is faulty.
- Fan not working or not connected.
- The ambient temperature is too high.
- The cooling air supply is insufficient or is too hot.
- The process gas is too hot or the maximum continuous operating pressure has been exceeded.
- The exhaust pressure of the XDS100B is too high. Check operation of the booster backing pump and suitability of the backing pump for the application.

### 5.7.2 The pump has failed to achieve the required performance

- The exhaust pressure of the XDS100B is too high. Check suitability of the backing pump for the application.
- If the electrical supply voltage is more than 10% below the lowest voltage specified on the voltage indicator, the pump may operate yielding a degraded vacuum performance.
- There is a leak in your vacuum system.
- Your pressure measurement technique or gauge head is unsuitable or gives an incorrect indication of pressure.
- Your vacuum fittings are dirty or damaged.
- The inlet strainer is blocked.
- There is a blockage or high pressure in the exhaust line.
- The pump contains traces of process vapours.
- The pump is outside the specified range of operating conditions.
- The tip seals need replacing.
- The inverter is current limiting the supply.
- The pump is in idle mode.

### 5.7.3 The pump is noisy

- The pump is contaminated with solid particles.
- The bearings are worn.
- Following tip seal replacement, the pump has not been vented and a build up of eroded tip seal dust is reducing running clearances. Refer to [Section 5.5](#) for further information.



#### 5.7.4 The pump surface temperature is high

- The ambient temperature is too high.
- The cooling air supply is insufficient or is too hot.
- The process gas is too hot or the maximum continuous operating pressure has been exceeded.
- The exhaust pressure is too high.

#### 5.7.5 The pumping speed is poor or if pump down time is too long

- The connecting pipelines are too small in diameter.
- The connecting pipelines are too long.
- The inlet strainer is blocked.
- There is a leak in the system.
- The inverter is current limiting the supply.
- The pump is in idle mode.

## 6 Storage and disposal

### 6.1 Storage

Use the following procedure to store the pump:

1. Shut down the pump as described in [Section 4.7](#).
2. Disconnect the pump from the electrical supply.
3. Place and secure protective covers over the inlet and outlet ports.
4. Store the pump in cool, dry conditions until required for use. When required, prepare and install the pump as described in [Section 3](#).

### 6.2 Disposal

Dispose of the pump and any components from it safely in accordance with all local and national safety and environmental requirements.

If this pump is to be returned to Edwards Vacuum Technology for disposal/ investigation. Particular care must be taken with components that have been contaminated with dangerous process substances.



#### **WARNING**

Do not incinerate fluoroelastomer seals, tip seal material and O-rings.

## 7 Service, spares and accessories

### 7.1 Introduction

Edwards products, spares and accessories are available from Edwards companies in Belgium, Brazil, Canada, France, Germany, Hong Kong, Italy, Japan, Korea, Switzerland, UK, USA and a world-wide network of distributors. The majority of these centres employ Service Engineers who have undergone comprehensive Edwards training courses. Order spare parts and accessories from your nearest Edwards company or distributor. When you order, state for each part required:

- Model and item number of your equipment.
- Serial number (if any).
- Item number and description of part.

### 7.2 Service

Edwards are supported by a worldwide network of Edwards Service Centres. Each Service Centre offers a wide range of options including: equipment decontamination; service exchange; repair; rebuild and testing to factory specifications. Equipment which has been serviced, repaired or rebuilt is returned with a full warranty.

Your local Service Centre can also provide Edwards engineers to support on-site maintenance, service or repair of your equipment.

For more information about service options, contact your nearest Service Centre or other Edwards company.

### 7.3 Accessories

#### 7.3.1 Electrical cables

Refer to [Table 10](#). The following electrical cables are available as accessories and should be used to connect the XDS100B to your electrical supply:

**Table 10 - Electrical cables**

Product description	Ordering information
Lead Assembly, 13 A, C19, UK	A505-05-003
Lead Assembly, 16 A, C19, Europe	A505-06-003
Lead Assembly, 15 A, C19, USA	A505-07-003
Lead Assembly, 20 A, C19, No Plug	A505-08-003

#### 7.3.2 Silencer

A silencer is available for the pump. The code number for the silencer is A505-97-001. Refer to [Section 3.6](#) for guidance on its use. A silencer spares kit, code number A505-97-801 is also available.

#### 7.3.3 Gas ballast adaptor

Fit the gas-ballast adaptor in place of the gas-ballast control on the pump. The adaptor allows you to connect a controlled supply of inert gas to the pump. Gas-ballast adaptor A505-02-000.

### 7.3.4 Solenoid operated pipeline valves

Fit the pipeline valve between your vacuum system and the pump inlet to provide additional system protection when the pump is switched off. The following valves are available as accessories and are recommended. (Refer to Table 11).

Table 11 - Solenoid operated pipeline valves

Product description	Ordering information
PV40EK Valve, 220-240 V 50/60 Hz, Aluminium	C414-01-000
PV40EK Valve, 220-240 V 50/60 Hz, Steel	C414-02-000
PV40EK Valve, 110-127 V 50/60 Hz, Aluminium	C414-03-000
PV40EK Valve, 110-127 V 50/60 Hz, Steel	C414-04-000

### 7.3.5 Tip seal and exhaust valve service kit

This kit contains all the necessary components to replace the tip seals. Tip seals should be replaced as a pair, and only simple tools are required. The kit part number is A732-01-801.