

# Instruction Manual

## iH Dry Pumping Systems





Description	Item Number
iH80	A590-00-xxx
iH160	A590-10-xxx
iH160HTX	A590-12-xxx
iH600	A590-20-xxx
iH1000	A590-30-xxx
iH1800	A590-40-xxx
iH1800HTX	A590-42-xxx
iH1800NRV	A590-50-xxx
iH1800NRV HTX	A590-52-xxx
Where xxx is as follows:	
460 V, 60 Hz, 3 phase	908
200/208 V, 50/60 Hz, 3 phase	945
380/415 V, 50 Hz, 3 phase	946
230 V, 60 Hz, 3 phase	957

Chemtech Scientific provides access to this content as a courtesy.  
We do not own the content contained in this document.  
All rights and credit go directly to its rightful owners.  
[www.chemtechsci.com](http://www.chemtechsci.com)  
Call us at: 484-424-9415



### Product Manual Addendum - Equipment types:

iH Vacuum Pump Range	GX Vacuum Pump Range	DiHxK Vacuum Pump Range
iF Vacuum Pump Range	iHxK Vacuum Pump Range	DiFxK Vacuum Pump Range
iGX Vacuum Pump Range	iFxK Vacuum Pump Range	EPX Vacuum Pump Range
IPX Vacuum Pump Range	iQ/QDP/QMB Vacuum Pump Ranges	iL Vacuum Pump Range
iXH Vacuum Pump Range		

Product Label	Overshipper Label	Pallet Marking
	 CB	 NW
Indicates toxic or hazardous substance contained in at least one of the homogeneous materials used for this part is above the limit requirement in SJ/T11363-2006. Environmental Protection Period is 20 years	Recyclable Cardboard	Recyclable Natural Wood

### Materials Content Declaration & Environmental Protection Use Period

The Chinese regulatory requirement on the Control of Pollution Caused by Electronic Information Products No. 39 (also known as 'China RoHS') mandates that manufacturers of certain categories of electronic products sold in China after 1st March 2007 –

- Mark the product and packaging
- Define the Product's Environment Protection Use Period (EPUP)
- Provide a Materials Content Declaration.

### Environmental Protection Use Period (EPUP)

This is the period in years during which the toxic or hazardous substances or elements contained in this product will not leak or mutate under normal operating conditions so that the use of such electronic information products will not result in any severe environmental pollution, any bodily injury or damage to any assets.

The Environmental Protection Use Period is **20** years for this product.

For the purposes of EPUP, normal operating conditions are considered to be use in accordance with the product's instruction manual.

### Materials Content Declaration

Part name	Toxic or Hazardous Substances and Elements					
	Lead (Pb)	Mercury (Hg)	Cadmium (Cd)	Hexavalent Chromium (Cr (VI))	Poly brominated biphenyls (PBB)	Poly brominated diphenyl ethers (PBDE)
Cartridge	○	○	x	x	○	○
Enclosure	○	○	x	x	○	○
Electronics and Controls	x	○	x	x	○	○
Cooling System	○	○	x	x	○	○
Purge System	○	○	x	x	○	○

○: Indicates that this toxic or hazardous substance contained in all of the homogeneous materials for this part is below the limit requirement in SJ/T11363-2006.  
 X: Indicates that this toxic or hazardous substance contained in at least one of the homogeneous materials used for this part is above the limit requirement in SJ/T11363-2006.

# Contents

Section	Page
<b>1 Introduction</b>	<b>1</b>
1.1 Scope and definitions	1
1.2 Applications	2
1.3 Description	3
1.3.1 The iH HTX system	3
1.3.2 The iH NRV systems	3
1.4 Priority of control	3
<b>2 Technical data</b>	<b>7</b>
2.1 General technical data	7
2.2 Electrical data	9
2.3 Loading	10
2.4 Connections	11
2.5 General data	12
<b>3 Installation</b>	<b>13</b>
3.1 Locate the dry pumping system	14
3.2 Lubrication	15
3.3 Connect the dry pumping system to your vacuum/exhaust system	15
3.4 Connect the iH1800HTX exhaust TMS	16
3.5 Connect to your factory extraction system (optional)	16
3.6 Connect the nitrogen supply	17
3.6.1 Flammable/pyrophoric materials	17
3.6.2 Gas purges	18
3.7 Leak-test the system	18
3.8 Electrical supply	18
3.8.1 Reconfigure the iH system for your electrical supply (if necessary)	19
3.8.2 Reconfigure the iH system for your electrical supply (iH80/600 only)	19
3.8.3 Connect the electrical supply	21
3.9 Connect an additional RF earth (ground) (optional)	23
3.10 Connect to your emergency stop circuit	23
3.11 Connect the cooling-water hoses	24
3.12 Accessories	24
3.13 Commission the system	25
3.14 Install additional safety equipment	26
<b>4 Operation</b>	<b>27</b>
4.1 Start-up	27
4.2 Status indicators	28
4.3 Manual shut-down	28
4.4 Automatic shut-down	29
4.5 Unplanned shutdown and alarms	29
4.6 Emergency stop	30
4.7 Restart the pump after an emergency stop or automatic shut-down	30
4.8 Single equipment monitor (SEM)	30
<b>5 Maintenance</b>	<b>31</b>
5.1 Safety and maintenance frequency	31
5.2 Relocate the system for maintenance	32
5.3 Cleaning the pump	33
5.4 General maintenance	33

5.5	Replace a fuse .....	34
5.6	Inspect the connections, pipelines, cables and fittings .....	34
6	Transportation, storage and disposal .....	35
6.1	Transportation .....	35
6.2	Storage .....	35
6.3	Disposal .....	35
7	Service, spares and accessories .....	37
7.1	Introduction .....	37
7.2	Service .....	37
7.3	Ordering accessories .....	37

For return of equipment, complete the HS Forms at the end of this manual.

## Illustrations

Figure		Page
1	iH applications chart .....	2
2	Priority of control .....	3
3	The controls/connectors on rear of pump .....	4
4	The controls/connectors on electrics box .....	4
5	Top view of pump .....	5
6	The front panel controls .....	5
7	Centre of gravity and levelling foot loads .....	10
8	System arrangement to reduce effective footprint (if required) .....	14
9	Reconfigure the iH system for your electrical supply .....	20
10	Reconfigure the pump-motor terminal-boxes (iH80/iH600 only) .....	21
11	Connect the electrical supply cable to the connector mating-half .....	23

## Tables

Table		Page
1	Technical data iH80, iH600 and iH1000 .....	7
1	Technical data iH160 and iH1800 .....	8
2	Technical data .....	8
3	Electrical data 200-208 V 50 Hz-230 V 60 Hz .....	9
3	Electrical data 380-415 V 50 Hz-460 V 60 Hz .....	9
4	Centre of gravity and levelling foot loads (Refer to <a href="#">Figure 7</a> ) .....	10
5	iH connector types .....	11
6	Technical data .....	12
7	Safety sensors .....	29
8	Accessories .....	37

## Associated publications

Publication title	Publication number
Vacuum Pump and Vacuum System Safety	P300-20-000
Semiconductor Pumping Application Guide	P411-00-090

# 1 Introduction

## 1.1 Scope and definitions

This manual provides installation, operation and maintenance instructions for the Edwards iH dry pumping systems. You must use your pumping system as specified in this manual.

Read this manual before you install and operate your pump. Important safety information is highlighted as WARNING and CAUTION instructions; you must obey these instructions. The use of WARNINGS and CAUTIONS is defined below.



### WARNING

Warnings are given where failure to observe the instruction could result in injury or death to people.

### CAUTION

Cautions are given where failure to observe the instruction could result in damage to the equipment, associated equipment and/or process.

The units throughout this manual conform to the SI international system of units of measurement.

In accordance with the recommendations of IEC1010, the following warning labels are on the pump:



Warning - refer to accompanying documentation.



Warning - moving parts present.



Warning - risk of electric shock.



Warning - heavy object.



Warning - hot surfaces.



RF earth (ground).

PE



Protective earth (ground).



Warning - pressurised.

# Introduction



Warning - use protective equipment.



Warning - Risk of explosion.

The Pressurised and Risk of explosion warnings only appear in this manual.

Material Safety Data Sheets for chemicals supplied by Edwards can be obtained by contacting Edwards.

## 1.2 Applications

If you use the iH system on an application for which it is not suitable (refer to Figure 1), you may invalidate your warranties. If in doubt, contact Edwards who will advise you as to the suitability of the iH system for any particular application.

Figure 1 - iH applications chart

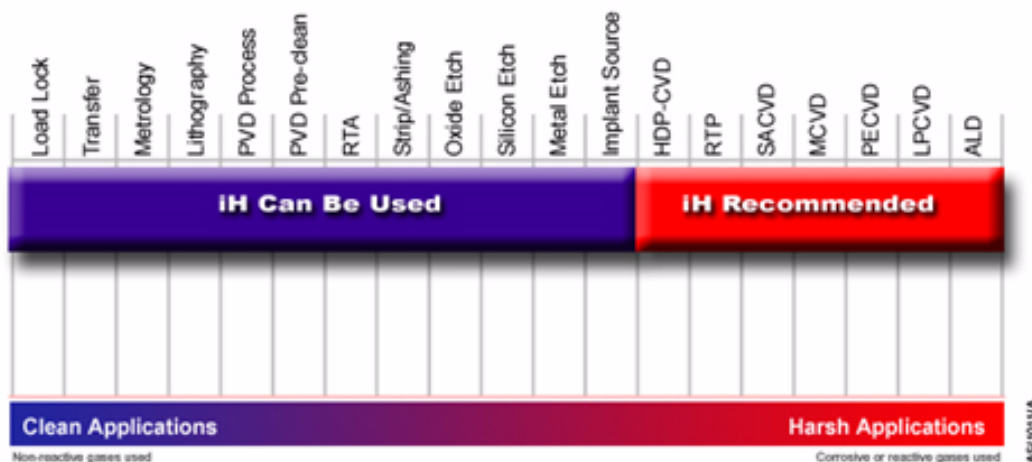

**Note:** This product is not ATEX compliant, a range of ATEX compliant pumping systems are available, contact Edwards for details.

## 1.3 Description

### 1.3.1 The iH HTX system

For enhanced performance on harsh duty processes, especially those prone to condensation of process gases inside the pumping system. This is achieved by:

- Increased dry pump operating temperature
- Increased gas purge capacity
- Increased exhaust diameter and exhaust TMS (Thermal Management System)
- Provision for optional heated exhaust purge.

### 1.3.2 The iH NRV systems

For Flat Panel Display processes.

## 1.4 Priority of control

The system can be controlled by a number of modules: the Pump Display Terminal (PDT), from the tool through the IM interface and communications module, iTIM, or from the Single Equipment Monitor (refer to [Figure 3](#)). Only one of these can have control of the iH system at any one time. That is, once one of these has control of the iH system, control requests from the others are denied.

The PDT indicates who is in control. LEDs are also provided on the rear panel, front panel or PDT, which illuminate to indicate 'in control'. Please refer to [Figure 2](#).

Figure 2 - Priority of control

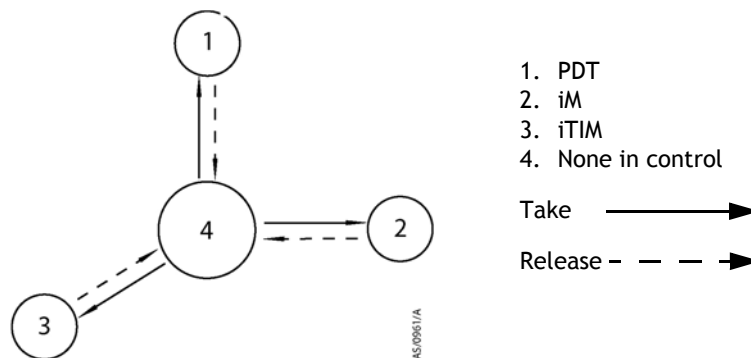

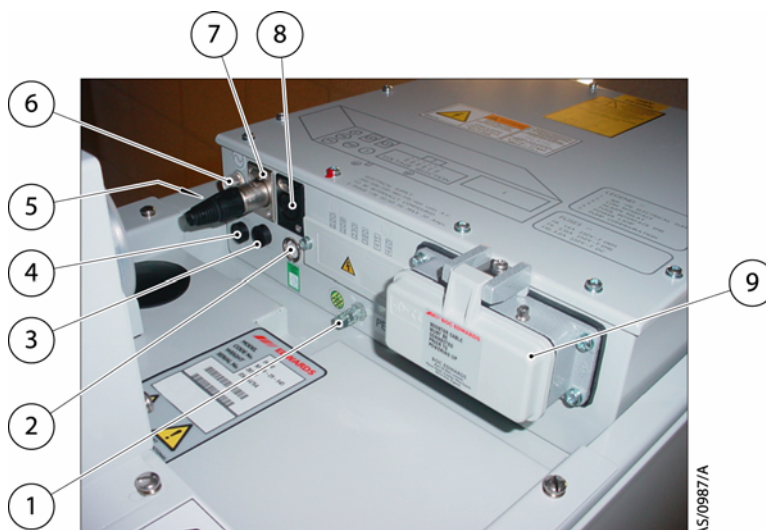

Figure 3 - The controls/connectors on rear of pump



- |                                    |                             |
|------------------------------------|-----------------------------|
| 1. Electrical box                  | 8. Nitrogen purge port      |
| 2. Exhaust check valve             | 9. Castor (4 off)           |
| 3. Cooling-water supply connection | 10. Exhaust enclosure       |
| 4. Seismic bracket (4 off)         | 11. Active gauge connection |
| 5. RF earth (ground) stud M6       | 12. iTIM connection         |
| 6. Cooling-water return connection | 13. Rear cover              |
| 7. Levelling feet (4 off)          |                             |

Figure 4 - The controls/connectors on electrics box



- |   |   |
|---|---|
| 1. Protective earth (ground) stud M5        | 6. Rear Power on lamp                   |
| 2. Exhaust gas outlet connection            | 7. EMS/Tool interface module connection |
| 3. d.c. Electrical supply fuse holder (F10) | 8. LON module connection                |
| 4. Emergency stop fuse holder (F9)          | 9. Electrical supply connection         |
| 5. Tool interface module fuse holder (F8)   |   |



Figure 5 - Top view of pump

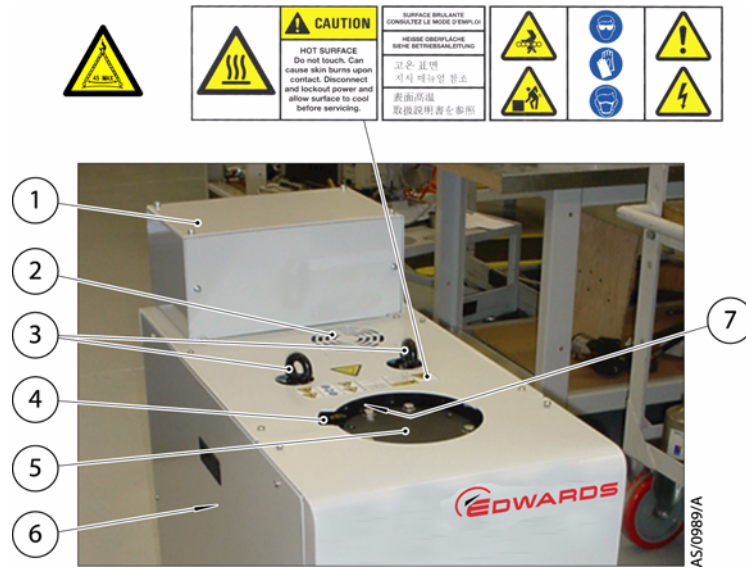

- 1. Inverter\*
- 2. Extraction port
- 3. Lifting eyebolts (2 off)
- 4. RF earth (ground) cable
- 5. Pumped gas inlet connection
- 6. Leak-test port (combination)
- 7. Leak-test port (pump only)

\* iH160/1000/1800 only.

Figure 6 - The front panel controls

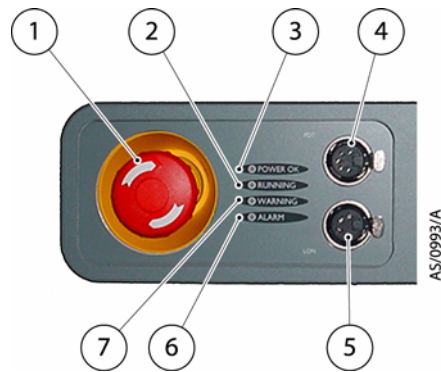

- 1. EMS button
- 2. Running LED (green)
- 3. Power OK LED (green)
- 4. Pump display terminal connection
- 5. LON module connection
- 6. Alarm LED (red)
- 7. Warning LED (amber)

## 2 Technical data

### 2.1 General technical data

Table 1 - Technical data iH80, iH600 and iH1000

Type	Characteristics	iH80	iH600	iH1000	Units
General	Dimensions (L (to exhaust enclosure) x W x H (to inverter))*	776 (909) x 390 x 529	776 (909) x 390 x 839	776 (909) x 390 x 839 (992)	mm
	Mass (excluding packaging)	240	415	430	kg
	Noise level (ultimate)	< 64	< 67	< 69	dB(A)
	Vibration level at inlet	< 1.8	< 1.8	< 1.8	mm s <sup>-1</sup>
	Initial force to push the pump	8	16	20	kg
	Sustained force to push the pump	5	7	8	kg
	Earth leakage	<1.1	<1.1	<3	mA
	Warm up time to nominal pumping performance	15	15	15	minutes
	Minimum warm up time to process gas pumping	4	4	4	hours
Performance 50 Hz / 60 Hz	Typical peak pumping speed	86 / 103	518 / 600	950 / 1000	m <sup>3</sup> h <sup>-1</sup>
	Ultimate (shaft seal purge only)	3 x 10 <sup>-2</sup> / 1 x 10 <sup>-2</sup>	2 x 10 <sup>-3</sup> / 7 x 10 <sup>-4</sup>	2 x 10 <sup>-3</sup> / 1 x 10 <sup>-3</sup>	mbar
	Maximum inlet pressure	Atmospheric	Atmospheric	Atmospheric	
	Maximum operating time at maximum inlet pressure	Continuous	1	Continuous	hour
Water cooling system	Minimum flow rate required	2	4	4	l min <sup>-1</sup>
	Typical heat removed from the system	2.5	3.2	3.2	kW
Connections	Pump inlet flange (bolted)	ISO63	ISO100	ISO100	
	Exhaust gas outlet	NW40	NW40	NW40	
	Extraction port	105	105	105	mm dia

\* Refer to Web for installation drawings.

**Table 1 - Technical data iH160 and iH1800**

Type	Characteristics	iH160	iH1800	Units
General	Dimensions (L (to exhaust enclosure) x W x H (to inverter))*	776 (909) x 390 x 529 (783)	986 (1059) x 470 x 888 (1094)	mm
	Mass (excluding packaging)	244	502	kg
	Noise level (ultimate)	<64	<69	dB(A)
	Vibration level at inlet	<1.8	<1.8	mm s <sup>-1</sup>
	Initial force to push the pump	8	25	kg
	Sustained force to push the pump	5	10	kg
	Earth leakage	< 3.8	< 6.8	mA
	Warm up time to nominal pumping performance	15	15	minutes
Performance 50 Hz / 60 Hz	Minimum warm up time to process gas pumping	4	4	hours
	Typical peak pumping speed	165	1800	m <sup>3</sup> h <sup>-1</sup>
	Ultimate (shaft seal purge only)	1x10 <sup>-2</sup>	1x10 <sup>-3</sup>	mbar
	Maximum inlet pressure	Atmospheric	Atmospheric	hour
Water cooling system	Maximum operating time at maximum inlet pressure	Continuous	Continuous	hour
	Minimum flow rate required	2	4	l min <sup>-1</sup>
Connections	Typical heat removed from the system	2.5	3.2	kW
	Pump inlet flange (bolted)	ISO63	ISO160	
	Exhaust gas outlet	NW40	NW40	
	Extraction port	105	50	mm dia

\* Refer to Web for installation drawings.

**Table 2 - Technical data**

Type	Characteristics	All	HTX only	Units
Gas system	Nitrogen supply pressure range	1.4 to 6.9	3.8 to 6.9	bar gauge
	Stability of supply	+/-2.4	+/-2.4	bar gauge
	Nitrogen supply quality	< 0.01	< 0.01	µm
	Nitrogen flow rate	44	76	slm
	Gas module pressure range	1	1	bar gauge
	Pressure transducer accuracy	+/-0.0041 at 0.4	+/-0.0041 at 0.4	bar gauge

## 2.2 Electrical data

**Table 3 - Electrical data 200-208 V 50 Hz-230 V 60 Hz**

Supply voltage and frequency			200-208 V 50 Hz	200-208 V 60 Hz	230 V 60 Hz
iH80 / iH160	HCDP	Full load (Amp)	14.4	14.9	14.4
		Motor rating (kW)	2.9	3.5	3.5
	Max power input to motor (kW)		3.65	4.48	4.48
iH600 / iH1000	HCDP	Full load (Amp)	14.4	14.9	14.4
		Motor rating (kW)	2.9	3.5	3.5
	HCMB	Full load (Amp)	11.8	11.8	11.7
		Motor rating (kW)	2.2	2.6	2.6
	Max power input to both motors (kW)		6.51	7.8	7.8
iH1800	HCDP	Full load (Amp)	14.4	14.9	14.4
		Motor rating (kW)	2.9	3.5	3.5
	HCMB	Full load (Amp)	14.4	14.9	14.4
		Motor rating (kW)	2.9	3.5	3.5
	Max power input to both motors (kW)		7.3	8.96	8.96

**Table 3 - Electrical data 380-415 V 50 Hz-460 V 60 Hz**

Supply voltage and frequency			380-415 V 50 Hz	460 V 60 Hz
iH80 / iH160	HCDP	Full load (Amp)	7.2	7.2
		Motor rating (kW)	2.9	3.5
	Max power input to motor (kW)		3.65	4.48
iH600 / iH1000	HCDP	Full load (Amp)	7.2	7.2
		Motor rating (kW)	2.9	3.5
	HCMB	Full load (Amp)	5.9	5.8
		Motor rating (kW)	2.2	2.6
	Max power input to both motors (kW)		6.51	7.8
iH1800	HCDP	Full load (Amp)	7.2	7.2
		Motor rating (kW)	2.9	3.5
	HCMB	Full load (Amp)	7.2	7.2
		Motor rating (kW)	2.9	3.5
	Max power input to both motors (kW)		7.3	8.96

### 2.3 Loading

Table 4 - Centre of gravity and levelling foot loads (Refer to Figure 7)

		iH80	iH600	iH1000	iH160	iH1800
Centre of gravity	A	661	661	661	661	661
	B	322	309	314	304	325
	C	159	163	163	163	198
	D	302	302	302	302	382
	E	293	466	481	364	528
Levelling loads	1	75	103	118	70	133
	2	66	119	115	65	125
	3	51	75	90	50	113
	4	48	118	107	60	132

Figure 7 - Centre of gravity and levelling foot loads

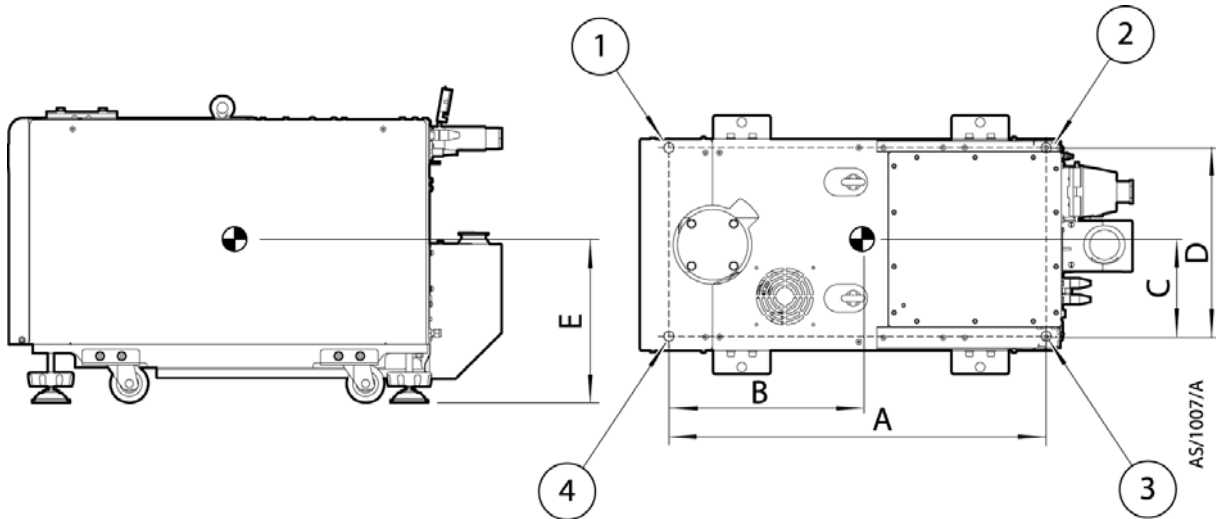

## 2.4 Connections

**Table 5 - iH connector types**

Description	Mating connector description / external supply rating	Internal supply rating
Electrical supply connector 1 - Phase 1 (R) 2 - Phase 2 (S) 3 - Phase 3 (T)	Harting HAN-K-4/2 16 mm <sup>2</sup> wire, 18 to 27 mm cable OD	
Pump display terminal connector	XLR type 5-way plug	24 V d.c. 0.75 A
Network LON communications connector	XLR type 4-way plug	24 V d.c. 0.75 A
Exhaust gas management interface 1 - normally open and 3 - common 2 - normally open and 4 - normally closed 3 - normally open and 6 - common	DIN type 6-pin plug 30 V a.c. 1 A 30 V a.c. 1 A 60 V d.c. 0.5 A	
Active gauge connector*	SCC68 socket	
Exhaust TMS power supply†	Edwards TMS type	
Tool interface module connector / EMS 1 and 2 - linked, remove - normally closed 3 and 4 - isolated auxiliary contacts 5 - continuous output 6 - return	XLR type 6-way plug  24 V a.c. 625 mA	
Tool interface adapter (iTIM)	D type 15-way plug	
External emergency stop switch		24 V a.c. 5 A (load 700 mA inductive)

\* *Optional accessory.*

† *HTX variants only.*

## 2.5 General data

**Table 6 - Technical data**

Item	Description	Rating	Units
Electrical	Supply voltage 3-phase	200-208/380 - 415 V, 50 Hz a.c. 200-208/230/460 V, 60 Hz a.c.	
	Recommended fuse / isolator rating	Full load current rating, refer to Table 3 Class CC fuse rated to 600V.	
	Voltage tolerance range	+/- 10%	V
	208 V and 415 V, 50 Hz only	+6% /-10%	V
	Installation category	II (IEC 664)	
	Harmonic voltage distortion factor	5%	
	Fuse types and ratings		
	F8	T1.6 A, 250 V	
	F9	T3.15 A, 250 V	
	F10	T5.0 A, 250 V	
Water cooling system	Maximum supply pressure	100	psig
	Minimum supply pressure	36	psig
	Minimum flow rate required	Refer to Table 1	
	Supply temperature range	10-30	°C
	Typical pressure differential across supply and return*	15	psig
	Water type	Treated or non-corrosive industrial	
	Maximum particle size	0.03	mm <sup>2</sup>
	Acidity	6.5 to 8.0	pH
	Hardness	<100	ppm
	Resistivity	>1	k cm
	Solids (turbidity)	<100	ppm
	Materials in contact with cooling water	Stainless steel, Nitrile, PTFE, copper, brass and fluoroelastomer	
Connections	Water cooling inlet	3/8 inch BSP male quick connector	
	Water cooling outlet	3/8 inch BSP female quick connector	
	Nitrogen inlet	1/4 inch tube fitting	
Materials in contact with process gas	Pump, shaft and rotors	Cast Iron, Steel, SG iron	
	Seals	PTFE and fluoroelastomer	
	Gas System	Stainless steel, Aluminium, brass and fluoroelastomer	
Operating conditions	Intended use	Indoor	
	Ambient temperature range:		
	Operating	5 to 40	°C
	Storage	-45 to 55	°C
	Relative humidity	10 to 90	%RH
	Maximum operating altitude	2000	m
Pollution degree	2 (IEC 61010)		

\* With cooling water supply temperature of 20°C and flow rate of 3 l min<sup>-1</sup>.



## 3 Installation



### WARNING

Obey the safety instructions given below and take the appropriate precautions. If you do not, you can cause injury to people and damage to equipment.



### WARNING

The system should not be operated with the Edwards panels removed.



### WARNING

The iH1800HTX has two separate power supplies, one for the pump system and the other for the exhaust TMS.

Potential hazards on the dry pumping system include electricity, hot surfaces, process chemicals, Fomblin oil, nitrogen and water under pressure.

Detailed safety information is given in [Section 4](#) and Edwards Publication Number P300-20-000 'Vacuum Pump and Vacuum System Safety'.

- Only Edwards engineers may install the dry pumping system. Users can be trained by Edwards to conduct the tasks described in this manual, contact your local service centre or Edwards for more information.
- Do not remove the temporary cover or blanking plate from the dry pumping system inlet and exhaust until you are ready to connect the dry pumping system to your vacuum or exhaust-extraction system. Do not operate the dry pumping system unless the inlet and exhaust are connected to your vacuum and exhaust-extraction system.
- Vent and purge the process system (if the dry pumping system is to replace an existing pumping system) with nitrogen for 15 minutes before you start installation work. Refer to [Section 5](#).
- Disconnect the other components in the process system from the electrical supply so that they cannot be operated accidentally.
- Electrical, nitrogen and water supplies are all potentially hazardous energy sources. Before carrying out any maintenance the supply of these sources should be locked and tagged out.
- The pump system includes provision for ventilation extraction and secondary containment of oil and water leaks. Any unintended overflows or spills must be removed immediately to avoid risk of slips.
- Obey all national and local rules and safety regulations when you install the dry pumping system. Consult Edwards Publication Number P300-20-000 (Vacuum Pump and Vacuum System Safety) before you pump hazardous materials. This publication is available on request: contact your supplier or Edwards.
- Route and secure cables, hoses and pipework during installation to avoid possible risk of trips.
- Be aware the exhaust TMS can be live and maintaining a high temperature of 150°C, even if the pumping system power supply is isolated. Disconnect the pump system TMS if the pump is switched off and disconnected.

### 3.1 Locate the dry pumping system



**WARNING**

You must use suitable lifting equipment to move the system. It is too heavy to lift by hand.



**WARNING**

Do not exceed the topple angle of 10° when moving the pump. Wheel the system on its castors to move it into its operating position. The system should only be wheeled short distances over flat surfaces. If the floor surface is uneven or has obstacles the system should be lifted with suitable lifting equipment.



**WARNING**

Ensure that the maximum angle between paired slings used to lift the iH system is 45°.

Use the following procedure to locate the iH system in its operating position. The iH system must be located on a firm, level surface, to ensure that the system is not damaged.

1. Use suitable lifting equipment attached to the lifting eyebolts (Figure 5, item 3) to move the iH system close to its final operating position.
2. Adjust the levelling feet (Figure 3, item 7) to make sure that the iH system is level and is not supported by the castors.
3. If required, the iH system can be secured to the floor by fitting suitable bolts or studs (not supplied) through the M10 docking points on the chassis. If vibration transmission to the floor is a concern, suitable vibration isolators (not supplied) should be fitted between the docking points and the bolt or stud, if doing this the levelling feet will need to be removed.
4. If preferred, the lifting eyebolts can be removed and replaced with the lifting eyebolt hole plugs supplied with the systems.
5. Ensure that access is possible to the emergency stop button (refer to Figure 6, item 1), if not use an iH Disconnect Box (refer to Section 7.3).

Figure 8 - System arrangement to reduce effective footprint (if required)

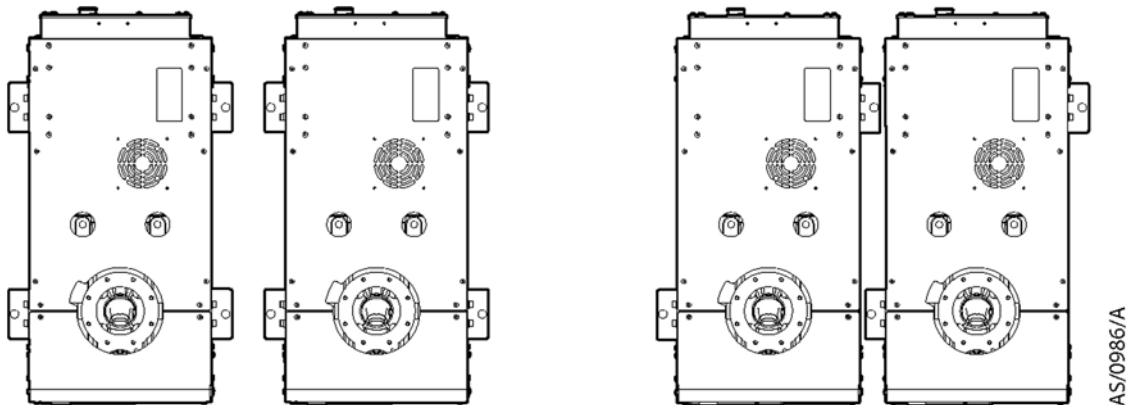

AS/0986/A

If you want to secure the iH in place to prevent inadvertent movement (for example, during an earthquake), take note of the following:

- The iH system seismic brackets (Figure 3, item 4) are designed to withstand a level 4 earthquake in a ground floor installation.
- The iH system can be secured to the floor by fitting suitable bolts or studs (not supplied) through the 17.5 mm hole in the seismic brackets.
- If vibration transmission to the floor is a concern, suitable vibration isolators (not supplied) should be fitted between the seismic brackets and the bolt or stud.
- Although the iH system is supplied with four seismic brackets, two brackets are capable of protecting the system during an earthquake. The system can therefore be secured as shown in Figure 8 for example, to reduce the effective system footprint if required.

If all four seismic brackets are to be used, ensure that the bolt spacing is adequate for the floor strength and loads anticipated.

## 3.2 Lubrication

### CAUTION

Ensure that the oil-levels in the HCDP pump and the HMB pump are correct. If a pump oil-level is incorrect, pump performance may be affected and the pump may be damaged.

The iH system is given a charge of oil before it leaves the factory. There is no requirement to adjust the oil level.

## 3.3 Connect the dry pumping system to your vacuum/exhaust system



### WARNING

Pipe the exhaust to a suitable treatment plant to prevent the discharge of dangerous gases or vapours to the surrounding atmosphere.



### WARNING

Do not operate the system with the exhaust pipeline blocked. If the exhaust pipeline is blocked, the system can generate exhaust pipeline pressures of up to 7 bar ( $7 \times 10^5$  Pa).

### CAUTION

Use a catchpot to prevent the drainage of condensate back into the iH system. Condensate that drains back into the iH could damage the HCDP pump.

Do not reuse any O-ring or O-ring assembly and do not allow debris to get into the iH system during installation.

When you connect your iH system to your vacuum system, take note of the following:

- To get the best pumping speed, ensure that the pipeline which connects the vacuum system to the iH system is the minimum length possible and has an internal diameter not less than the iH system inlet-port.
- Ensure that all components in the vacuum pipeline have a maximum pressure rating which is greater than the highest pressure that can be generated in your system.

- Incorporate flexible pipelines in the vacuum pipeline to reduce the transmission of vibration and to prevent loading of coupling-joints. We recommend that you use Edwards braided flexible pipelines. The pipelines should be suitable for 110 °C.
  - Adequately support vacuum/exhaust pipelines to prevent the transmission of stress to pipeline coupling-joints.
  - Incorporate a pressure gauge in the inlet pipeline, so that you determine that the iH system operates correctly.
  - You must be able to isolate the iH system inlet from the atmosphere and from your vacuum system if you have pumped or produced corrosive chemicals.
  - The outlet of the exhaust pipe can have a check-valve fitted which prevents the suck-back of exhaust vapours after the iH system is shutdown. The check-valve also provides additional attenuation of the pulses in exhaust pressure.
  - On very dusty applications, use a low-impedance inlet-filter to minimise damage to the pump.
  - The exhaust pipelines should be suitable for 150 °C for HTX systems.
1. Remove the temporary cover or blanking plate from the inlet of the iH system. Retain the nuts, bolts, washers and blanking plate for future use. Retain the temporary cover for future use on non-contaminated pumps only.
  2. Use the O-ring supplied and suitable nuts, bolts and washers (not supplied) to connect the inlet-flange (Figure 5, item 5) of the iH system to your vacuum system.
  3. Use the NW40 trapped O-ring and clamp supplied to connect the exhaust outlet (Figure 3, item 2) on the exhaust pipe, to your exhaust extraction system. If check valve/elbow are not required for your application refer to the web.

### 3.4 Connect the iH1800HTX exhaust TMS



#### WARNING

Ensure that the exhaust TMS is connected to the electrical supply through a suitably rated isolator/connector.

Refer to Edwards instruction manual Y140-00-880 'TMS Temperature Management System' for details. A separate power supply can be ordered if required, refer to [Section 7.3](#) for details.

### 3.5 Connect to your factory extraction system (optional)

Refer to [Figure 5](#), item 2.

## 3.6 Connect the nitrogen supply

---

### CAUTION

Ensure that your nitrogen supply conforms to the requirements given in the Technical Data Section. If it doesn't, the flow sensors may not operate correctly, the gas pipelines may become blocked or the iH system may be damaged.

---

Refer to [Figure 3](#), item 8.

For optimum nitrogen, ensure that your nitrogen supply complies with [Table 2](#).

### 3.6.1 Flammable/pyrophoric materials



### WARNING

You must obey the instructions and take note of any precautions given below to ensure that pumped gases do not enter their flammable ranges.

---

When flammable or pyrophoric materials are present within the equipment you must:

- Not allow air to enter the equipment
- Ensure that the system is leak tight
- Ensure that pumped gases do not enter their flammable range. This can be achieved by diluting flammable gases/vapours or oxidisers in the pump by supplying sufficient inert gas purge, for example dilution with nitrogen to below one quarter LEL (lower explosive limit) or, if that is not practical, to below 60% LOC (limiting oxidant concentration).
- For further information please refer to Semiconductor Pumping Application Guide (Publication no. P411-00-090) or contact Edwards: refer to the address page at the rear of this manual for details of your nearest Edwards company.

### 3.6.2 Gas purges



#### WARNING

If you use inert gas purges to dilute dangerous gases to a safe level, ensure that the pump is shut down if an inert gas supply fails.

Switch on the inert gas purge to remove air from the pump and the exhaust pipeline before the process starts. Switch off the purge flow at the end of the process only after the remaining flammable gases or vapours have been purged from the exhaust pipeline.

If liquids that produce flammable vapours could be present in the pump foreline, then the inert gas purge to the dry pumping system should be left on all the time this liquid is present. Flammable liquids could be present in the foreline as a result of condensation or may be carried over from the process.

When calculating the flow rate of inert gas required for dilution, consider the maximum flow rate for the flammable gases/vapours that could occur. For example, if a mass flow controller is being used to supply flammable gases to the process, you should assume a flow rate for flammable gases that could arise if the mass flow controller is fully open.

Continually measure the inert gas flow rate: if the flow rate falls below that required, then the flow of flammable gases or vapours to the pump must be stopped.

## 3.7 Leak-test the system



#### WARNING

Leak test the system after installation and seal any leaks found to prevent leakage of dangerous substances out of the system and leakage of air into the system.

*Note:* If you need further information on leak-testing, look it up on the Web using URL at the start of manual, or contact your supplier or Edwards for advice.

Refer to Figure 5, items 6 or 7.

## 3.8 Electrical supply



#### WARNING

This equipment is suitable for Installation Category II as defined in IEC 60664-3. Connect the system to the electrical supply through a suitably rated isolator/connector for your dry pumping system. (Refer to Table 6).



#### WARNING

Ensure that the system and your electrical supply cable are suitably protected against earth (ground) faults and that the earth (ground) conductor of the electrical supply cable is longer than the phase conductors in the connector. You must fit a second protective earth (ground) conductor (with a cross-sectional area at least equal to phase conductor size) to the protective earth (ground) stud.



#### WARNING

All connections to the interface control must be double insulated or have equivalent protection. Do not connect voltages greater than 30 V a.c. or 60 V d.c. to the control/interface connections. If you do, the interface control will not provide protection against electric shock.

### 3.8.1 Reconfigure the iH system for your electrical supply (if necessary)

#### CAUTION

iH160/1000/1800 systems are supplied already configured for your electrical supply. The iH system cannot be reconfigured between the low voltage (200 V to 230 V) and high voltage (380 V to 460 V) ranges.

Contact your supplier or Edwards if you wish to use the iH system with a power supply in a different voltage range to that specified on the rating plate. To reconfigure the iH system within its standard voltage range, refer to [Figure 9](#) and ensure that the correct transformer primary tapping is selected using the following procedure:

Ensure power supplies to the iH system are disconnected.

Undo the screws (2) which secure the cover (1) to the Electrics Box (3) and remove the cover.

Ensure that the common cable (4) is correctly connected to the common terminal on the terminal-block (6).

Ensure that the voltages select cable (5) is connected to the correct voltage terminal of the terminal-block (6) for your electrical supply.

Refit the cover (1) and secure with the two screws (2).

### 3.8.2 Reconfigure the iH system for your electrical supply (iH80/600 only)

If you want to use an iH80 or iH600 system with a different electrical supply, use the following procedure:

1. Refer to [Figure 10](#). Undo and remove the six screws which secure the rear cover over the HCDP pump-motor, and remove the rear cover.
2. Undo and remove the four screws which secure the cover to the pump-motor terminal-box.
3. Look at the links in the terminal-box (1):
  - For high voltage operations (380-415 V at 50 Hz or 460 V at 60 Hz), ensure that the links (2) are in the positions shown in [Figure 10](#).
  - For low voltage operations (200-208 V at 50 Hz or 200-230 V at 60 Hz), ensure that the links (2) are in the positions shown in [Figure 10](#).
4. Refit the cover to the pump-motor terminal-box and secure with four screws.
5. Refit the rear cover and secure with the six screws.
6. If you have iH600, continue at [Step 7](#), otherwise continue at [Section 3.8.3](#).
7. Undo and remove the four screws, which secure the electrics box to the rear of the iH system, then carefully lower and support the module. Ensure that you do not disconnect, break or damage any of the cables connected to the module.
8. Carry out steps 2, 3 and 4.

Refit the electrics box to the rear of the iH system and secure with the four screws: ensure that you do not trap any of the cables connected to the electrics box.



Figure 9 - Reconfigure the iH system for your electrical supply

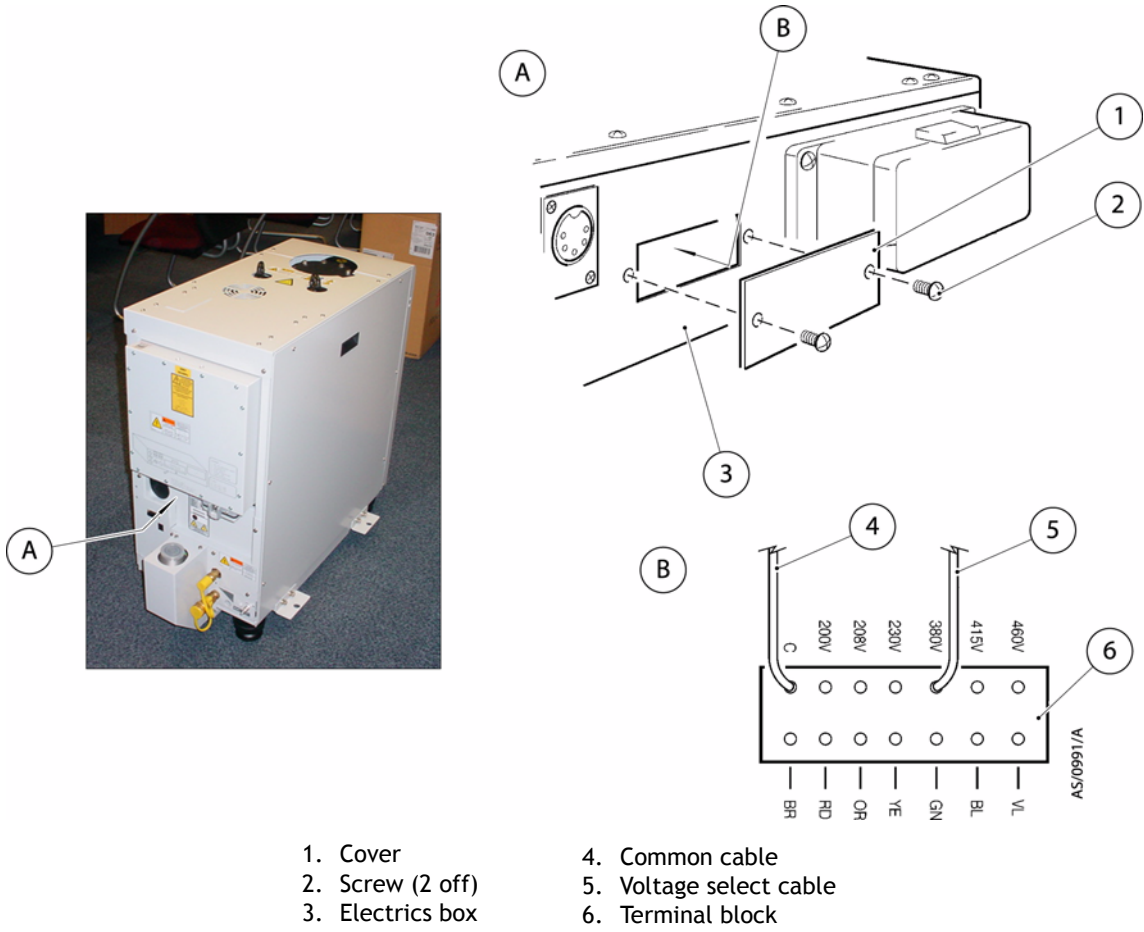
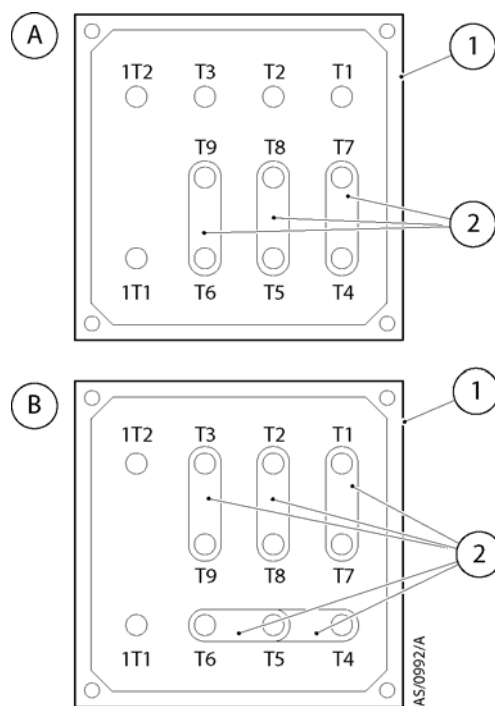

Figure 10 - Reconfigure the pump-motor terminal-boxes (iH80/iH600 only)



1. Pump-motor terminal-box
2. Links

### 3.8.3 Connect the electrical supply

#### CAUTION

This is an industrial (Class A) product as defined by EN61326. To ensure compliance with European Electromagnetic Compatibility (EMC) requirements for EMC emissions, please note that it is not intended for use in domestic buildings, or in properties directly connected to an electrical supply network which also supplies domestic buildings.

#### CAUTION

Do not connect voltages greater than specified in Table 5 to the control/interface connections. If you do, the interface control may be damaged.

- Notes:**
1. Edwards recommend that the electrical supply be connected to a suitable isolator, which is easily accessible for maintenance and clearly identified.
  2. If you need further information on connecting the electrical supply, look it up on the Web using URL at the start of manual, or contact your supplier or Edwards for advice.

3. *On an iH160, 1000 or 1800 system, the earth (ground) installation must ensure that there is an equipotential zone around the iH system: the voltage between the protective earth (ground) stud on the iH system and any other conducting surface within 2 metres of the iH system must be <math><30\text{ V r.m.s.}</math>*
4. *If you connect the electrical supply to an iH160, 1000 or 1800 system through ELCB relays, they must be suitable for protection of equipment with a d.c. component in the fault current, and suitable for short duration switch-on surges, and for high leakage current (for example, type B, according to prEN50178). The iH160, 1000 or 1800 system is for use only with equipment that has no accessible terminals.*

Refer to [Figure 4](#), item 9.

Use the following procedure to connect the electrical supply to the iH system. When you make your electrical supply cable, ensure that the earth (ground) conductor is longer than the phase conductors. This will ensure that if the cable is accidentally dragged and the strain relief bush on the electrical supply connector mating-half fails, the earth (ground) conductor will be the last conductor to be pulled from the connector.

1. Refer to [Figure 11](#). Remove the connector block from the cover (10) of the mating-half supplied for the electrical supply connector, then pass a suitable cable (9) through the strain relief bush (8) on the cover (10). Refer to [Section 2](#) for suitable cable sizes.
2. Connect the cable phase wires to the pins in the connector block as shown in [Table 5](#).
3. Connect the earth (ground) wire of the cable to one of the two earth (ground) screws (7) on the side of the connector block.
4. Refit the cover (10) to the connector block then tighten the strain relief bush (8).
5. Fit the mating-half to the electrical supply connector (2) on the Electrics Box (1).
6. Connect the other end of the electrical supply cable to your electrical supply through a suitable isolator, or via the disconnect box (refer to [Section 7.3](#)).
7. On iH80, 160 and 600 systems, we recommend that you fit a second protective earth (ground) conductor to the protective earth (ground) stud on the Electrics Box ([Figure 3](#), item 1) and connect the other end of this conductor to your factory earth (ground). On an iH1000 and 1800 systems, you must fit a second protective earth (ground) conductor.

Figure 11 - Connect the electrical supply cable to the connector mating-half

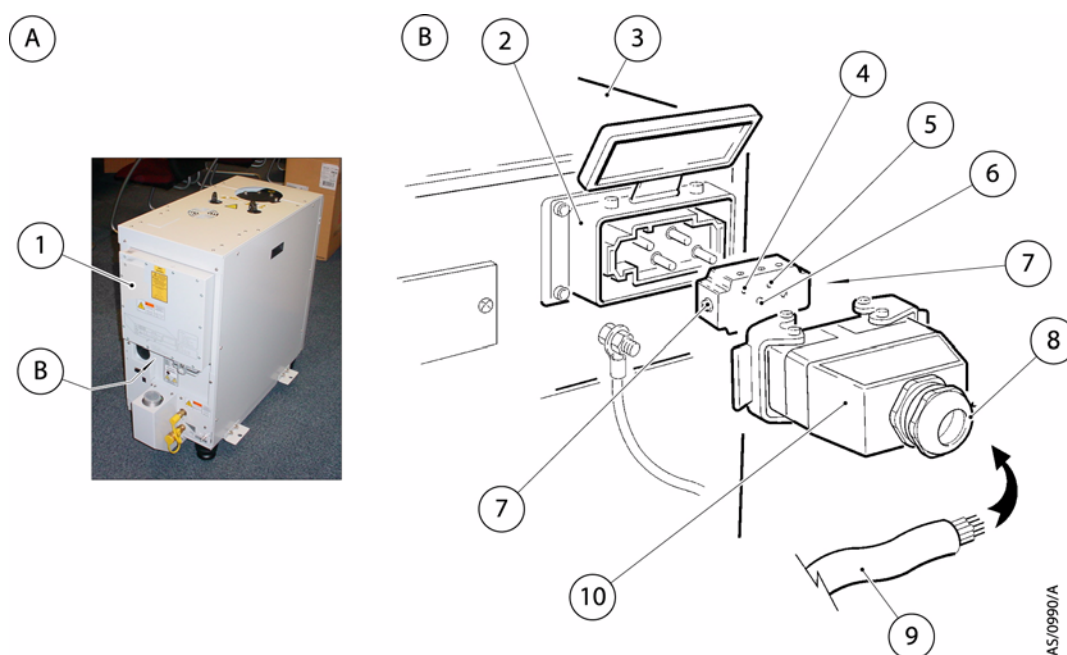

- |                                |                            |
|--------------------------------|----------------------------|
| 1. Electric box                | 6. Pin 3 (phase 3)         |
| 2. Electrical supply connector | 7. Earth (ground) screw    |
| 3. Electric box                | 8. Strain relief bush      |
| 4. Pin 1 (phase 1)             | 9. Electrical supply cable |
| 5. Pin 2 (phase 2)             | 10. Cover                  |

### 3.9 Connect an additional RF earth (ground) (optional)

If you will operate the iH system in an area subject to high RF (radio frequency) emissions, in accordance with good RF installation practice, we recommend that you:

- Use a star washer to connect the end of the earth (ground) cable (Figure 5, item 4) connected to the iH inlet to one of the bolts that you use to secure the inlet-flange.
- Connect an additional earth (ground) cable to the RF earth (ground) stud (Figure 3, item 5). You must use a suitable low-impedance cable (for example, use braided cable).

### 3.10 Connect to your emergency stop circuit

**Note:** If you do not connect to your own control equipment, you must fit the Tool Interface Module plug supplied (Figure 4, item 7) on the rear of the iH system. If you do not, you will not be able to operate the iH system.

If required, you can connect your own control equipment to the iH system to shut it down in an emergency using the EMS connection (Figure 4, item 7 and Table 5). The emergency stop control must be compliant with IEC 60947-5-1 (This should be a red self latching mushroom push button on a yellow background.).

### 3.11 Connect the cooling-water hoses



#### WARNING

Do not leave the cooling-water supply turned on until after you complete the electrical installation of the pump. If you do, condensation may form inside the enclosure and there may be a risk of electric shock.

- Notes:**
1. For optimum water-cooling, ensure that your cooling-water supply complies with the data given in Table 1 and that they are connected in parallel. Refer to Figure 3, items 3 and 6. Edwards would recommend that quick connectors be used to reduce the risk of water spillage during connection/disconnection.
  2. For minimum water consumption, regulate the cooling-water flow to the iH system.

Connect the cooling-water supply as follows:

1. Use 3/8 inch BSP male pipe fittings (which you must supply) to fit the female quick-release connector to the cooling-water supply hose and to fit the male quick-release connector to the cooling-water return hose.
2. Remove the dust-caps from the cooling-water inlet and outlet.
3. Connect your water return hose to the cooling-water outlet (Figure 3, item 6) and connect your water supply hose to the cooling-water inlet (Figure 3, item 3).
4. Turn on the cooling-water supply.
5. Inspect the water hoses, pipelines and connections and check that there are no leaks.

Turn off the water supply while you complete the remainder of the installation procedures.

### 3.12 Accessories

Refer to the individual accessories manuals for installation, information, refer to Section 7.3.

The disconnect box when fitted, is used to energize and isolate the power supply to the system. It also allows the isolation of the electrical supply during an emergency, and for maintenance and trouble shooting the system, thereby satisfying SEMI S2 requirements. The photohelic switch/gauge when fitted, allows monitoring for loss of extraction from the enclosure, thereby satisfying SEMI S2 requirements. Refer to the individual accessories manuals for information about installation.

### 3.13 Commission the system



#### WARNING

During some application cycles it is possible that the system may exceed OSHA 1910.95 Occupational Noise Exposure Limits, the EU noise directive 2003/10/EC or other regional noise limits dependant upon the process, duty cycle, installation or environment in which being operated. A sound pressure survey must be conducted after installation and, if necessary, controls implemented to ensure that the relevant limits are not exceeded during operation and that adequate precautions are taken to prevent personnel from exposure to high noise levels during operation.

1. Switch on the external electrical supply and check that the power OK LED (Figure 6, item 3) goes on. If the LED does not go on, contact Edwards or refer to the Web.
2. Switch on the cooling-water and nitrogen supplies.
3. Ensure that the exhaust-extraction system is not blocked (for example, that valves in the exhaust-extraction system are open).
4. Ensure that all openings to atmospheric pressure in the foreline vacuum system are closed.
5. Connect the PDT to the front of the iH system (Figure 6, item 4).
6. Press CONTROL button, press ENTER button, LOCAL CONTROL green LED illuminates, press START, press ENTER.
7. If the iH system starts and continues to operate, continue at Step 8. If a warning or alarm condition is indicated:
  - Shut-down the iH system: refer to Section 4.3.
  - Contact Edwards or refer to the Web.
8. Look at the pressure gauge in your inlet pipeline:
  - If the pressure is increasing, the HCDP pump-motor terminal-box (and/or if you have an iH160, 1000 or 1800 system, the HMB pump-motor terminal-box) is incorrectly wired: immediately shut down the iH system, correct the electrical wiring, then repeat this procedure from step three again.
  - If the pressure is decreasing continue at Step 9.
9. After you have commissioned the iH system:
  - If you want to continue to operate the iH system, refer to Section 4.1, Step 4.
  - Otherwise, shut-down the system: refer to Section 4.3.

### 3.14 Install additional safety equipment

**WARNING**

If your Process Tool/control system needs to know the total flow rate of nitrogen to the system for safety reasons, install suitable measurement equipment in the nitrogen supply pipeline.

**WARNING**

If you use the nitrogen purges to dilute dangerous gases to a safe level, ensure that the system shuts down if the nitrogen supply to the system fails.

If the sensors or microprocessors fail, the total flow rate of nitrogen displayed or output by the iH system may be incorrect. If you need to know the total flow rate of nitrogen to the dry pump for safety reasons, you should therefore fit suitable measurement equipment in the nitrogen supply pipeline. If you fit a rotameter, ensure that it is suitable for use with nitrogen and that it is correctly calibrated.

If the nitrogen supply to the iH system fails, a warning message will be shown on the Pump Display Terminal (if fitted) and will be sent to the Interface Module(s) connected to the iH system. Ensure that your installation is configured so that it remains safe if there is a failure of the nitrogen supply to the iH system.

If an alarm condition is detected (and the iH system is not configured to 'run til crash' refer to [Section 4.4](#)) the iH system will shutdown automatically. You must ensure that your installation remains safe if the iH system shuts down automatically.



## 4 Operation



### WARNING

Do not operate the system with any enclosure panels removed or damaged and do not touch any parts of the pump(s) when the system is on. Surfaces of the pump(s) are very hot and can cause injury to people.



### WARNING

Do not operate the system with any enclosures removed or damaged. If you do there may be a risk of an electric shock.

### 4.1 Start-up



### WARNING

Ensure that it is safe to start the system. If you do not (and, for example, maintenance is being performed on components downstream of the system), you could cause injury to people.



### WARNING

After the power is applied, the contactors will pull in automatically and all mains circuits will be energised.

### CAUTION

The system is designed to ride through short term power interruption and to automatically restart once the power is restored.

### CAUTION

Do not operate the pump if the pipeline is restricted or blocked as the pump will not operate correctly and may be damaged.

Refer to [Section 1.1](#) and [3.6](#).

1. Switch on the cooling-water and nitrogen supply.
2. Switch on the electrical supply.
3. Check that the exhaust-extraction system is not restricted, and that any valves in the exhaust-extraction system are open.

The pump can be started using either the iTIM, the PDT or the IM.

iTIM and IM operation:

4. Use your control equipment to set the pump start/stop signal to the interface connector and check that the Running LED is illuminated.
  - Control must be taken with the iTIM. The message 'iTIM IN CONTROL' will be displayed on the PDT if connected.

PDT operation:

5. If the system is to be operated using the PDT.
  - Connect the PDT to the required PDT connection, front (Figure 6, item 4).
  - Press CONTROL button, press ENTER button, LOCAL CONTROL green LED illuminates.
  - Press START button.
  - Press ENTER.
  - The system will start and the Running LEDs will be illuminated.

## 4.2 Status indicators

Refer to Figure 6.

## 4.3 Manual shut-down



### WARNING

If you shut the system down and don't isolate it from the electrical supply, do not disconnect the Pump Display Terminal or release control from the Pump Display Terminal or front panel. If you do the system could be started by another Module.



### WARNING

Do not remove the inlet connections until the pump has been allowed to stop rotating and the power has been isolated. The pump can take up to three minutes to completely stop.

The pump can be shutdown using either the iTIM, the PDT or the IM. Note that only the item in control can stop the pump (refer to Section 1.4).

iTIM and IM operation:

1. Use your control equipment to reset the pump start/stop signal to the interface connector. The Running LED (Figure 6, item 2) will then go off, and the pump running status output signal will open.

PDT operation:

### CAUTION

If you stop the pump without the nitrogen purge cycle i.e. using the EMS button, on processes that have condensable or solid by-products then the pump may not restart.

1. Use the PDT to select Auto or Fast shut-down mode, both introduce nitrogen purge cycle.

If the pump is not going to be required for some time, switch off the electrical supply and the cooling-water supply.

## 4.4 Automatic shut-down

### CAUTION

If you select 'Run 'til crash', the pump(s) can be damaged and you may invalidate any warranties on the iH system equipment.

Normally, if an alarm condition exists, the iH control system will shutdown the iH system. If required you can request 'run 'til crash' operation. In this mode of operation, most alarm conditions will be ignored and the pump(s) will continue to operate. For safety reasons the following alarms will shut-down the iH system even if you have selected 'run til crash':

**Note:** 'Run 'til crash' is automatically reset to 'off' when the electrical supply is removed.

- HCDP CURRENT HIGH/LOW (error numbers 310 and 312).
- HCDP THERMISTOR HIGH (error number 512).
- EXHAUST PRESSURE (error number 3912).

On an iH160, 1000 or 1800 system, the following alarms will cause only the HMB pump to shut down, provided 'run til crash' is not selected:

- HMB POWER HIGH/LOW (error numbers 810 and 812).
- HMB PHASE IMBALANCE (error number 1012).

On an iH160, 1000 or 1800 system, the following alarms will cause only the HMB pump to shut down, whether 'run til crash' is selected or not:

- HMB CURRENT HIGH LOW (error numbers 710 and 712).

HMB THERMISTOR HIGH (error number 912).

## 4.5 Unplanned shutdown and alarms

The iH system is fitted with a number of pump protection sensors (refer to [Table 7](#)) that will give warnings and alarms. The decision on whether or not to shutdown the pump is left with the tool.

If the iH system has an unplanned shutdown, ensure that the cause of the shutdown is identified and rectified before restarting. If you are in any doubt, please call a Edwards Service Engineer.

**Table 7 - Safety sensors**

Safety sensor	Shut-down condition
HCDP pump-motor thermistor	When the thermistor in the HCDP pump-motor indicates that the temperature of the pump-motor is nominally 150 °C.
HMB pump-motor thermistor <sup>*</sup>	When the thermistor in the HMB pump-motor indicates that the temperature of the pump-motor is nominally 150 °C.
Exhaust pressure transducer <sup>†</sup>	When the pressure in the exhaust pipeline is 9 psig or higher.
Photohelic switch	When the extraction from the exhaust enclosure is lost.

<sup>\*</sup> iH600/1000/1800 systems only.

<sup>†</sup> Accessory.

## 4.6 Emergency stop

*Note:* The emergency stop switch is not an electrical isolator.

*Note:* The use of emergency stop will not automatically shut down the load lock pump (if fitted); you must shut down the load lock pump separately.

To shut down the iH system in an emergency, press the emergency stop switch (Figure 6, item 1). Alternatively, you can operate the emergency stop controls in your own control system if you have connected your emergency stop circuit to the iH system as described in Section 3.10.

When emergency stop is selected:

- The pump (and the booster pump) is switched off.
- The solenoid-valve(s) in the Gas Module close, to switch off the supply of nitrogen to the pump.
- The solenoid-valve(s) in the temperature control manifold(s) de-energise with loss of temperature control.
- The Pump Display Terminal will display 'STOP ACTIVATED'. (If connected)
- The Running LED will go off.
- The Alarm LED illuminates.

## 4.7 Restart the pump after an emergency stop or automatic shut-down

*Note:* If the iH system has automatically shut down because of high pump power, check that the pump is free to rotate before you restart the iH system: refer to the Web.

If you have used the emergency stop switch on the front panel to shut down the iH system, you must reset the emergency stop switch before you can restart the iH system. Turn the emergency stop switch to reset it, then restart the iH system as described in Section 4.1.

If the iH system has been automatically shut down because of an alarm condition, the alarm condition must be rectified before you can restart the iH system. Restart the iH system as described in Section 4.1.

## 4.8 Single equipment monitor (SEM)

---

### CAUTION

Ensure that you use the correct configuration setpoints for your application. If you do not, the iH system may be damaged during operation.

---

If there is an SEM connected to your iH system, you are able to download configuration sets, which contain preset configuration values, for example setpoints. Contact Edwards or go to the Web for more details.

## 5 Maintenance



### WARNING

Only personnel specially trained to perform electrical maintenance should attempt troubleshooting inside electrical enclosures. These enclosures contain hazardous voltages and are not operator areas.



### WARNING

Leak test the system after maintenance and seal any leaks found to prevent leakage of dangerous substances out of the system and leakage of air into the system.

### 5.1 Safety and maintenance frequency



### WARNING

Obey the safety instructions given below and take the appropriate precautions. If you do not, you can cause injury to people and damage to equipment.



### WARNING

Electrical, nitrogen and water supplies are all potentially hazardous energy sources. Before carrying out any maintenance the supply of these sources should be locked and tagged out.



### WARNING

The iH1800HTX has two separate power supplies, one for the pump system and the other for the exhaust TMS.



### WARNING

Personal protection equipment should be checked and used as specified by its supplier. Hazardous chemicals that have been pumped are located within the pumps and piping. Use of suitable protective gloves and clothing along with a respirator is recommended if contact with substances is anticipated.

Particular caution should be exercised when working with hydrocarbons which may have been exposed to temperatures greater than 260 °C. Refer to Edwards Material Safety Data Sheets for detailed information.

- Ensure that the maintenance technician is familiar with the safety procedures which relate to the products pumped.
- Allow the pumps to cool to a safe temperature before you fit lifting bolts or start maintenance work.
- Vent and purge the dry pumping system with nitrogen before you start any maintenance work.
- Isolate the dry pumping system and other components in the process system from the electrical supply so that they cannot be operated accidentally. Note that the emergency stop switch on the dry pumping system is not an electrical isolator, unless a disconnect box accessory is installed.
- Wait for at least four minutes after you have switched off the electrical supply before you touch any electrical component on the dry pumping system.

- Route and secure cables, hoses and pipelines during maintenance to avoid possible risk of trips or entrapment.
- Ensure that any oil or water collected in the secondary containment drip tray is removed before moving the system.
- The enclosure panels should only be removed with the use of a special tool, when the system has been switched off and allowed to cool sufficiently (as an indication the system should be left for one hour with cooling water still connected at 1 l min<sup>-1</sup>).
- Wear the appropriate safety-clothing when you come into contact with contaminated components. Dismantle and clean contaminated components inside a fume-cupboard.
- Re-check the pump rotation direction if the electrical supply has been disconnected.
- O-ring replacement intervals vary depending on your application.
- Dispose of components, grease and oil safely.
- Take care to protect sealing-faces from damage.

Do not touch or inhale the thermal breakdown products of fluorinated materials which may be present if the iH system has been overheated to 260 °C and above. These breakdown products are very dangerous. Fluorinated materials in the iH system may include oils, greases and seals. The iH system may have overheated if it was misused, if it malfunctioned or if it was in a fire. Edwards Material Safety Data Sheets for fluorinated materials used in the pump are available on request: contact your supplier or Edwards. (refer to the address page at the rear of this manual for contact details).

The iH system requires little user maintenance. Safety sensors fitted to the iH system do not require routine maintenance. The maintenance operations you can carry out are described in the following sections, any other maintenance must be carried out by Edwards service centres (refer to [Section 7](#)). The frequency of maintenance operations depends on your process. Adjust the frequency of maintenance operations according to your experience.

When you maintain the iH system, use Edwards maintenance and service kits. These contain all of the necessary seals and other components necessary to complete maintenance operations successfully. Ensure that your nitrogen and cooling-water supplies comply with the data given in [Section 2](#) and that they are connected in parallel. Contact Edwards or refer to the Web.

## 5.2 Relocate the system for maintenance



### WARNING

The substances that accumulate in the exhaust-pipe, elbow and check-valve can be dangerous. Do not allow these substances to come into contact with your skin or eyes. Do not inhale vapours from these substances. Fit blanking caps to the inlet and outlet flanges when you move the exhaust-pipe, elbow or check-valve around your workplace.



The majority of synthetic oils/grease can cause inflammation of the skin (dermatitis). Safety precautions must be taken to prevent prolonged skin contact with these substances. Use of suitable protective gloves and clothing along with a respirator is recommended if contact with the substance is anticipated.



System process gases and residue can be highly toxic. Take all necessary precautions when handling components that have, or could have, come into contact with them, including O-rings, lubricants and all exhaust accessories.



### WARNING

You must use suitable lifting equipment to move the system. It is too heavy to lift by hand.

**WARNING**

Do not exceed the topple angle of 10° when moving the pump. Wheel the system on its castors to move it into its operating position. The system should only be wheeled short distances over flat surfaces. If the floor surface is uneven or has obstacles the system should be lifted with suitable lifting equipment.

**CAUTION**

Drain the cooling-water from the iH system, if you will transport or store it in conditions where the cooling-water could freeze. If you do not, cooling-water may freeze in the iH system and damage the pump(s) and/or the cooling-water pipelines.

If you want to remove the iH system from its operating location and move it to another location where you will do maintenance, use the following procedure:

1. Purge the iH system and shut down the iH system as described in [Section 4](#) and allow the iH system to cool down.
2. Isolate the power by disconnecting the mating-half from the electrical supply connector, then isolate the water and the gas purge supply.
3. Switch off your nitrogen and cooling water supplies. Disconnect the nitrogen supply, taking care as any trapped gas under pressure is released. Disconnect the cooling-water supply followed by the cooling-water return.
4. Disconnect the inlet and outlet from the vacuum and exhaust systems and fit blanking caps.
5. If necessary, disconnect the iH air-extraction port from your factory extraction system.
6. If necessary disconnect any accessories from the iH system.
7. Adjust the levelling feet so that the iH system rests on the castors.
8. Move the iH system to the location where you will do maintenance.

After maintenance is complete, re-install the iH system as described in [Section 3](#).

### 5.3 Cleaning the pump

**CAUTION**

Do not use cleaning materials based on strong alkalis, aggressive or chlorinated solvents. Do not use cleaning materials containing abrasives.

Inspect the pump monthly and, if necessary, wipe the outside clean with a soft lint free cloth and a proprietary cleaning material based on demineralised water or isopropanol.

### 5.4 General maintenance

The following maintenance can be carried out on the system, refer to Web and/or contact Edwards for details and training:

- Check purge gas flow rates
- Inspect and clean exhaust pipe, elbow, and check valve
- Check oil levels
- Change oil
- Check TMS operation.

---

## 5.5 Replace a fuse

---



### WARNING

Ensure that you replace a fuse with a new fuse of the correct rating. If you do not, the system will not be adequately protected and you can damage the system or cause injury to people. Do not remove the cover from the electrics box. High voltages exist in the electrics box when it is connected to the electrical supply. There are no spare parts that can be serviced in the electrics box.

---

You can only change the low voltage fuses F8 to F10 (Figure 4, items 3 to 5) for the d.c. electrical supply, the iM interface and communications module and the emergency stop circuit. Only change a fuse if you have identified and rectified the cause of the failure.

To change a fuse, refer to Figure 4 and use the following procedure. If the fuse immediately fails when you replace it, there may be an electrical fault: contact your supplier or Edwards for advice.

1. Use a flat-bladed screwdriver to undo the fuse holder (items 3 to 5) by a 1/4 of a turn, then remove the fuse holder from the Electrics Box.
2. Remove the failed fuse from the fuse holder.
3. Fit a new fuse of the correct rating in the fuse holder. Refer to Table 6 for the fuse ratings.

Refit the fuse holder in the Electrics Box, then use a flat-bladed screwdriver to turn the fuse holder clockwise by a 1/4 of a turn to secure it in place.

## 5.6 Inspect the connections, pipelines, cables and fittings

1. Remove the enclosure side and top panels.
2. Check that all the connections are secure; tighten any loose connections. Inspect all cables, pipelines, hoses and connections and check that they are not corroded or damaged and do not leak; repair or replace any pipelines, hoses and connections that are corroded or damaged, or which leak.

Refit the enclosure side and top panels.



## 6 Transportation, storage and disposal

### 6.1 Transportation



#### WARNING

Do not drain the oil from the pump(s) whether dangerous substances have been pumped or not. You must fit blanking plates to seal all vacuum inlet and outlet ports (to prevent possible oil leakage). You must ensure that the system is correctly labelled, if in doubt contact Edwards.

Follow the procedure laid out in [Section 6.2](#) and then read form HS1 and fill out form HS2, which can be found at the back of this manual.

### 6.2 Storage

#### CAUTION

Drain the cooling-water from the iH system, if you will transport or store it in conditions where the cooling-water could freeze. If you do not, the cooling-water may freeze in the iH system and damage the pump(s) and/or the cooling-water pipelines.

Store the iH system as follows:

1. Follow the procedure set out in [Section 5.2](#).
2. Store the iH system in clean dry conditions until required.
3. When required for use, prepare and install the iH system as described in [Section 3](#) of this manual.

### 6.3 Disposal



#### WARNING

Dispose of the system and any components safely and in accordance with all local and national safety and environmental requirements.

Edwards products are supported by a world-wide network of Edwards Service Centres. Each Service Centre offers a wide range of options including disposal. Refer to [Section 7.2](#) for more information.

Pump system materials suitable for recycling include cast iron, steel, SG iron, PTFE, stainless steel, brass, aluminium, zinc alloy, nickel, mild steel, ABS.

Take particular care with the following:

- Fluoroelastomers which may have decomposed as the result of being subjected to high temperatures.
- Components which have been contaminated with dangerous process substances.

## 7 Service, spares and accessories

### 7.1 Introduction



#### WARNING

Whenever you return the dry pumping system to a Edwards Service Centre or other Edwards company, you must comply with the requirements of Section 6 and with the requirements of the Return of Edwards Equipment Procedure (refer to forms HS1 and HS2 at the rear of this manual).

- Notes:**
1. Whenever you return the iH system to a Edwards Service Centre or other Edwards company, you must comply with the requirements of Section 6 and with the requirements of the Return of Edwards Equipment Procedure (refer to forms HS1 and HS2 at the end of Important Safety Information).
  2. You must not drain the oil from the iH pump. You must clearly state the pump is full of oil when you complete form HS2.

Edwards products, spares and accessories are available from Edwards companies in Belgium, Brazil, Canada, China, France, Germany, Israel, Italy, Japan, Korea, Singapore, Switzerland, United Kingdom, U.S.A and a world-wide network of distributors. The majority of these centres employ Service Engineers who have undergone comprehensive Edwards training courses.

Order spare parts and accessories from your nearest Edwards company or distributor. When you order, please state for each part required:

- Model and Item Number of your equipment
- Serial number (if any)
- Item Number and description of the part.

### 7.2 Service

Edwards products are supported by a world-wide network of Edwards Service Centres. Each Service Centre offers a wide range of options including: equipment decontamination; service exchange; repair; rebuild and testing to factory specifications.

Equipment that has been serviced, repaired or rebuilt is returned with a full warranty. Your local Service Centre can also provide Edwards engineers to support on-site maintenance, service or repair of your equipment.

For more information about service options, contact your nearest Service Centre or other Edwards company.

### 7.3 Ordering accessories

Table 8 - Accessories

Accessory	Item Number
Pump display terminal 5-way XLR plug (PDT)	D372-80-700
PDT extension cables XLR 5 way	
3 m	D373-70-591
5 m	D373-70-592
10 m	D373-70-595
15 m	D373-70-596
25 m	D373-70-597

Table 8 - Accessories (continued)

Accessory	Item Number
Exhaust temperature sensor	A532-07-000
Active gauge connection kit	D372-41-000
iTIM	
E73+A1+T1	D374-20-000
E73+A1+T1 serial	D374-21-000
MCM+L1	D374-22-000
MCM+L1 serial	D374-23-000
PC interface kits	
Desktop	D372-18-100
Laptop (USA)	D372-18-200
Laptop (Europe)	D372-18-300
Laptop (UK)	D372-18-400
Laptop (Japan)	D372-18-500
PCMCIA Laptop	D372-17-000
Nitrogen flow switch	A532-54-000
IH Disconnect box	U20000445
IH Photohelic switch / gauge kit	U30004021
Heated exhaust purge kit (HTX variants)	A533-24-015
TMS control unit (HXT variants)	
230 V, 50 Hz, single phase	Y142-01-000
208 V, 60 Hz, 3-phase	Y142-02-000
200V, 50/60 Hz, 3-phase	Y142-03-000
IH80, 600, and 1000 Enclosure extraction fan kit	A505-39-000
PDT Holster	D372-09-800
PDT Adaptor, 5-way XLR plug/RJ12 socket	D373-70-526