

Instruction Manual

iQ Dry Pumping System

Chemtech Scientific provides access to this content as a courtesy.
We do not own the content contained in this document.
All rights and credit go directly to its rightful owners.
www.chemtechsci.com
Call us at: 484-424-9415



iQ Dry Pumping System - Setup Password

The setup password for this equipment is preset as follows:

SETUP PASSWORD: 202

You can remove this sheet from the instruction manual and retain it in a safe place to prevent unauthorised access to the setup menus in the iQ system.

(This page deliberately left blank)

CONTENTS

Section	Title	Page
1	INTRODUCTION	1-1
1.1	Scope and definitions	1-1
1.2	ATEX directive implications	1-2
1.3	The iQ system	1-3
1.4	The iQDP pump	1-3
1.5	The iQDP pump gas system	1-5
1.6	Gas Modules	1-5
1.6.1	Introduction	1-5
1.6.2	iQDP Shaft-Seals Purge Module	1-5
1.6.3	iQDP Gas-Ballast Module	1-7
1.6.4	iQDP Gas System Module Series 2	1-9
1.7	The iQMB mechanical booster pump	1-9
1.8	Temperature control system	1-12
1.8.1	iQDP pump temperature control system	1-12
1.8.2	iQMB pump temperature control system	1-14
1.9	Exhaust system	1-14
1.10	Electrical system	1-15
1.10.1	Introduction	1-15
1.10.2	Electrics Module	1-15
1.10.3	Sensor Monitoring Module	1-20
1.11	Control functions	1-22
1.11.1	Priority of control	1-22
1.11.2	Setpoints, warning and alarm conditions	1-22
1.11.3	Safety sensors	1-23
1.12	Pump Display Module accessory	1-23
1.13	iQ Interface Module accessories	1-28
1.14	iQ PC Interface Kit accessory	1-28
1.15	iQ Central Monitoring System	1-28
1.16	Labels	1-28
2	TECHNICAL DATA	2-1
2.1	General	2-1
2.2	Performance	2-1
2.3	Cooling-water supply	2-1
2.4	Temperature control system	2-13
2.5	Lubrication	2-13
2.5.1	iQDP pump	2-13
2.5.2	iQMB pump	2-14
2.6	Exhaust-silencer	2-14
2.7	Exhaust check-valve	2-14
2.8	Electrical data	2-14
2.9	Gas system	2-15
2.10	Materials in contact with process gases	2-17
2.11	Default setpoints	2-17
2.12	Connections	2-19

Section	Title	Page
3.23	Fit the Acoustic Enclosure (optional)	3-30
4	PUMP DISPLAY MODULE MENUS AND DISPLAY FORMATS	4-1
4.1	Introduction	4-1
4.2	General operation	4-2
4.3	The CANCEL button	4-2
4.4	Display text and variable text	4-2
4.5	Wrap-around	4-3
4.6	Timeout	4-3
4.7	Menu structure	4-3
4.8	Example	4-3
5	OPERATION	5-1
5.1	ATEX directive implications	5-1
5.1.1	Introduction	5-1
5.1.2	Flammable/pyrophoric materials	5-1
5.1.3	Gas purges	5-2
5.2	Introduction to operation	5-3
5.3	Configure the system	5-3
5.3.1	Change the setpoints	5-3
5.3.2	Use the default setpoints	5-4
5.3.3	Change iQ system configuration information	5-5
5.4	Change the display format	5-5
5.4.1	Change the normal display	5-5
5.4.2	Change the pressure display units	5-6
5.4.3	Change the temperature display units	5-6
5.4.4	Change the language of display messages	5-6
5.5	Take and release control	5-6
5.6	Start-up	5-6
5.7	Check the Gas Module nitrogen pressure and adjust if necessary	5-7
5.8	Monitor the status of the iQ system	5-7
5.9	Warning and alarm indications	5-8
5.10	Manual shut-down	5-10
5.11	Automatic shut-down	5-11
5.12	Emergency stop	5-12
5.13	Restart after emergency stop or automatic shut-down	5-12
5.14	Operation of iQ system components	5-13
5.15	Operation of the load-lock pump	5-14
6	MAINTENANCE	6-1
6.1	Safety	6-1
6.2	Maintenance plan	6-2
6.3	Inspect the connections, pipelines and cables	6-2
6.4	Inspect and clean the exhaust-silencer	6-3
6.5	Check the iQMB pump oil-levels	6-5
6.6	Inspect and clean the exhaust check-valve	6-6
6.7	Check the iQDP pump oil-level	6-8

Section	Title	Page
6.8	Check the iQDP pump coolant-level	6-8
6.9	Relubricate the iQDP pump rotor bearings	6-10
6.10	Relubricate the iQMB pump rotor bearings (iQMB250F & iQMB500F only)	6-11
6.11	Change the iQDP pump oil	6-12
6.12	Change the iQMB pump oil	6-12
6.13	Adjust the Pump Display Module display viewing angle	6-13
6.14	Replace an Electrics Module fuse	6-13
6.15	Replace the Gas Module	6-14
6.15.1	Remove the old Gas Module	6-14
6.15.2	Fit the new Gas Module	6-16
6.16	Replace the Pump Display Module	6-17
6.17	Relocate the iQ combination pumping system for maintenance	6-17
6.18	Replace the iQMB pump	6-18
6.19	Replace the iQDP pump with the iQMB pump connected to the process system (booster frame mounted combination pumping systems only)	6-19
6.20	Zero the Gas Module flow transducers	6-20
6.21	Fault finding	6-20
6.21.1	Warning and alarm message fault finding	6-20
6.21.2	Service LED fault finding	6-21
6.21.3	Other fault finding	6-21
7	STORAGE AND DISPOSAL	7-1
7.1	Storage	7-1
7.2	Disposal	7-1
8	SERVICE, SPARES AND ACCESSORIES	8-1
8.1	Introduction	8-1
8.2	Service	8-1
8.3	Spares	8-1
8.3.1	Pumps	8-1
8.3.2	Other spares	8-2
8.3.3	Greases and oils	8-2
8.4	Accessories	8-2
8.4.1	Gas modules	8-2
8.4.2	iQMB Motor Ancillaries Kits	8-2
8.4.3	iQMB Booster Connection Kits	8-3
8.4.4	iQ Acoustic Enclosures	8-3
8.4.5	iQMB Booster Frames	8-3
8.4.6	QMB Booster Frame Connection Kits	8-4
8.4.7	iQMB Booster Frame Acoustic Enclosures	8-4
8.4.8	OLM500 Oil-Level Monitor	8-4
8.4.9	iQ Exhaust Temperature Sensor	8-4
8.4.10	iQ Pump Display Module and extension cables	8-5
8.4.11	iQ Water Flow-Switch	8-5

Section	Title	Page
8.4.12	iQ Interface Modules	8-5
8.4.13	iQ PC Interface Kits	8-6
8.4.14	iQ Central Monitoring System	8-6

RETURN OF BOC EDWARDS EQUIPMENT

Tables

Table	Title	Page
1-1	Safety sensors	1-23
2-1	Technical data	2-2
2-2	Cooling-water consumption	2-2
2-3	Full load current ratings	2-15
2-4	Nitrogen purge flow rates: Shaft-Seals Purge Module	2-16
2-5	Nitrogen purge flow rates: Gas Ballast Module and Gas System Module Series 2	2-16
2-6	Electrics Module default setpoints	2-17
2-7	Gas-Ballast Module default setpoints	2-18
2-8	Gas System Module Series 2 default setpoints	2-18
2-9	Sensor Monitoring Module default setpoints	2-19
3-1	Installation checklist	3-2
3-2	Checklist of components	3-4
3-3	DIP switches 3 and 4 positions	3-6
3-4	DIP switches 1 and 2 positions	3-6
3-5	Pins in the emergency stop connector	3-16
3-6	Pins in the GRC bypass connector	3-16
3-7	Pins in the electrical supply connector	3-22
3-8	Adjust the TCV on the iQDP40	3-30
3-9	Adjust the TCV on the iQDP80	3-30
4-1	Menu structure	4-4
5-1	Setpoints which you can adjust with the Pump Display Module	5-4
5-2	Status menu sensor reading displays	5-9
6-1	Maintenance plan	6-2
6-2	Warning messages	6-22
6-3	Alarm messages	6-31
6-4	Fault messages	6-33
6-5	Fault parameters	6-34
6-6	Fault types	6-35

Illustrations

Figure	Title	Page
1-1	Components of the iQ pumping system	1-4
1-2	Schematic diagram of the iQ gas system with a Shaft-Seals Purge Module	1-6
1-3	Schematic diagram of the iQ gas system with a Gas-Ballast Module	1-8
1-4	Schematic diagram of the iQ gas system with a Gas System Module Series 2	1-11
1-5	Services connections	1-13
1-6	Schematic diagram of the electrical system	1-17
1-7	Side and rear panels of the Electrics Module	1-19
1-8	Top panel of the Sensor Monitoring Module	1-21
1-9	Front panel of the Pump Display Module	1-25
1-10	Bottom panel of the Pump Display Module	1-25
1-11	Labels on the iQ system	1-26
2-1	Dimensions of iQDP40 and iQDP80 systems without acoustic enclosures (mm)	2-3
2-2	Dimensions of iQDP40 /80 systems with direct mounted iQMB250F pump, without acoustic enclosures (mm)	2-4
2-3	Dimensions of iQDP40 /80 systems with direct mounted iQMB500F pump, without acoustic enclosures (mm)	2-5
2-4	Dimensions of booster frame mounted iQ systems, without acoustic enclosures (mm)	2-6
2-5	Typical pumping speeds for iQDP40	2-7
2-6	Typical pumping speeds for iQDP80	2-7
2-7	Typical pumping speeds for iQDP40/iQMB250F	2-8
2-8	Typical pumping speeds for iQDP80/iQMB250F	2-8
2-9	Typical pumping speeds for iQDP80/iQMB500F	2-9
2-10	Typical pumping speeds for iQDP80/iQMB1200F	2-9
2-11	iQDP40 power curves	2-10
2-12	iQDP80 power curves	2-10
2-13	iQMB250 power curves	2-11
2-14	iQMB500 power curves	2-11
2-15	iQMB1200 power curves	2-12
3-1	Remove the iQ system from the pallet	3-5
3-2	Components of the iQMB pump	3-8
3-3	iQMB pump sight-glasses	3-9
3-4	iQDP pump components	3-11
3-5	Configure the Electrics Module	3-18
3-6	iQDP40 and iQMB250/500F low voltage configuration	3-19
3-7	iQDP40 and iQMB250/500F high voltage configuration	3-19
3-8	iQDP80 and iQMB1200F low voltage configuration	3-20
3-9	iQDP80 and iQMB1200F high voltage configuration	3-20
3-10	Connect the electrical supply cable to the connector mating-half	3-23
3-11	Front panel of the Shaft-Seals Purge Module	3-28
3-12	Front panel of the Gas-Ballast Module and the Gas System Module Series 2	3-29
4-1	Menu logic	4-5
4-2	Switch on menu	4-6
4-3	Switch off menu	4-7

Illustrations (continued)

Figure	Title	Page
4-4	Normal menu	4-8
4-5	Status menu	4-9
4-6	Control menu	4-11
4-7	Setup menu	4-12
4-8	Run til crash menu	4-15
4-9	Messages menu	4-15
4-10	Setpoints menu	4-16
4-11	Units menu	4-18
4-12	Timeout menu	4-18
4-13	Normal display menu	4-19
4-14	Service menu	4-20
4-15	Serial menu	4-22
4-16	Zero sensors menu	4-24
4-17	View TIM I/O menu	4-24
4-18	Configure menu	4-25
4-19	Manual menu	4-28
4-20	View Status menu	4-31
4-21	Warning and alarm messages menu	4-33
6-1	Exhaust-silencer	6-4
6-2	Exhaust check-valve	6-7
6-3	iQDP pump rotor bearing relubrication	6-10
6-4	iQMB pump rear bearing relubrication	6-11
6-5	Fit the Gas Module	6-15

Supplementary Publications

The Supplementary Publications appropriate to your iQ system will be supplied with the pumping system. Where appropriate, the corresponding instruction manual will also be supplied with any accessory that you order.

Title	Publication Number
iQDP Acoustic Enclosures	A532-01-880
iQ Exhaust Temperature Sensor	A532-07-880
iQ Water Flow-Switch	A532-49-880
OLM500 Oil-Level Monitor	A504-34-880
iQMB Booster Connection Kits	A532-31-880
QMB and iQMB Booster Frame Connection Kits	A528-65-880
QMB and iQMB Booster Frames	A528-37-880
iQMB Booster Frame Acoustic Enclosures	A532-70-880

1 INTRODUCTION

1.1 Scope and definitions

This manual provides installation, operation and maintenance instructions for the BOC Edwards iQ Dry Pumping Systems. You must use the iQ systems as specified in this manual.

Read this manual before you install and operate the iQ system. Important safety information is highlighted as WARNING and CAUTION instructions; you must obey these instructions. The use of WARNINGS and CAUTIONS is defined below.

WARNING

Warnings are given where failure to observe the instruction could result in injury or death to people.

CAUTION

Cautions are given where failure to observe the instruction could result in damage to the equipment, associated equipment or process.

Throughout this manual, page, figure and title numbers are in the form 'S-N', where 'S' specifies the section and 'N' specifies the number of the page, figure or table in the section.

The units used throughout this manual conform to the SI international system of units of measurements. Also, throughout this manual, wherever nitrogen flow rates are specified, the abbreviation 'slm' is used to mean 'standard l min⁻¹': this is a flow of 1 l min⁻¹ at an ambient temperature of 0 °C and a pressure of 1013 mbar (1.013 x 10⁵ Pa).

The following symbols may appear on the iQ system:



Caution - refer to accompanying documents.



Caution - risk of electric shock.



Caution - hot surfaces.



Caution - static sensitive devices.

1.2 ATEX directive implications

Note: The following information only applies to an iQ system fitted with an iQDP Gas System Module Series 2 (harsh duty processes). iQ systems fitted with an iQDP Shaft-Seals Purge Module (light duty) or with an iQDP Gas-ballast Module (medium duty) are not ATEX compliant.



- This equipment is designed to meet the requirements of Group II Category 3 equipment in accordance with Directive 94/9/EC of the European Parliament and the Council of 23rd March 1994 on the approximation of the laws of the Member States concerning equipment and protective systems intended for use in potentially explosive atmospheres. (The ATEX Directive)

The ATEX Category 3 applies in respect of potential ignition sources internal to the equipment. An ATEX Category has not been assigned in respect of potential ignition sources on the outside of the equipment as the equipment has not been designed for use where there is an external potentially explosive atmosphere.

There is no potential source of ignition within the pump during normal operation but there may be potential sources of ignition under conditions of predictable and rare malfunction as defined in the Directive. Accordingly, although the pump is designed to pump flammable materials and mixtures, operating procedures should ensure that under all normal and reasonably predictable conditions, these materials and mixtures are not within explosive limits. Category 3 is considered appropriate for the avoidance of ignition in the case of a rare malfunction which allows flammable materials or mixtures to pass through the pump while within their explosive limits.

- When flammable or pyrophoric materials are present within the equipment you must:
 - Not allow air to enter the equipment.
 - Ensure that the system is leak tight.
 - Use an inert gas purge (for example, a nitrogen purge) to dilute any flammable gases or vapours entering the pump inlet, and/or use an inert gas purge to reduce the concentration of flammable gases or vapours in the pump and in the exhaust pipeline to less than one quarter of the gases' published lower explosive limits (LEL).
- For further information, please contact BOC Edwards: refer to the Addresses page at the end of this manual for details of your nearest BOC Edwards company.

1.3 The iQ system

The iQ system operates at pressures between atmospheric and ultimate vacuum with no lubricating or sealing fluid in the pumping chamber(s). This ensures a clean pumping system without back-migration of oil into the system being evacuated.

The iQDP40 system has an iQDP40 dry pump and the iQDP80 system has an iQDP80 dry pump. The iQ combination systems have an iQDP40 or iQDP80 with a iQMB mechanical booster fitted to the inlet of the iQDP pump. The iQMB pump can be directly mounted on the iQDP inlet (as shown in Figure 1-1) or can be mounted in an iQMB booster frame (as shown in Figure 2-4).

Both the iQDP and iQMB pumps have enclosed, water-cooled motors. The iQ system is therefore suitable for applications in clean environments where fan cooling is unacceptable.

The iQ system has a Gas Module which introduces purge gas into the iQDP pump. Three types of Gas Module are available, suitable for light, medium and harsh duty processes: refer to Section 1.6. If necessary (for example, if you want to use the iQ system in a different process), you can change the Gas Module.

You can manually control the iQ system through an optional Pump Display Module accessory: see Section 1.12. Alternatively, you can use your process tool or other control equipment to control the operation of the iQ system through an Interface Module accessory (refer to Section 1.13), or you can use the iQ Single Pumpset Monitor accessory to control the operation of the iQ system (refer to Section 8.4.13). The remainder of this manual describes the use of the Pump Display Module to operate the iQ system: for use of another accessory to operate the iQ system, refer to the instruction manual supplied with the accessory.

The components of the iQ system are described in the following sections.

1.4 The iQDP pump

The iQDP pump is a four-stage, positive displacement rotary pump in which pairs of intermeshing rotors (of different profiles mounted on common shafts) are held in correct phase relation by a pair of timing-gears. The timing-gears and the adjacent double-row angular contact ball-bearings, are oil lubricated.

The pump has an indirect cooling-system and the pump-motor is water cooled: see Section 1.8.1.

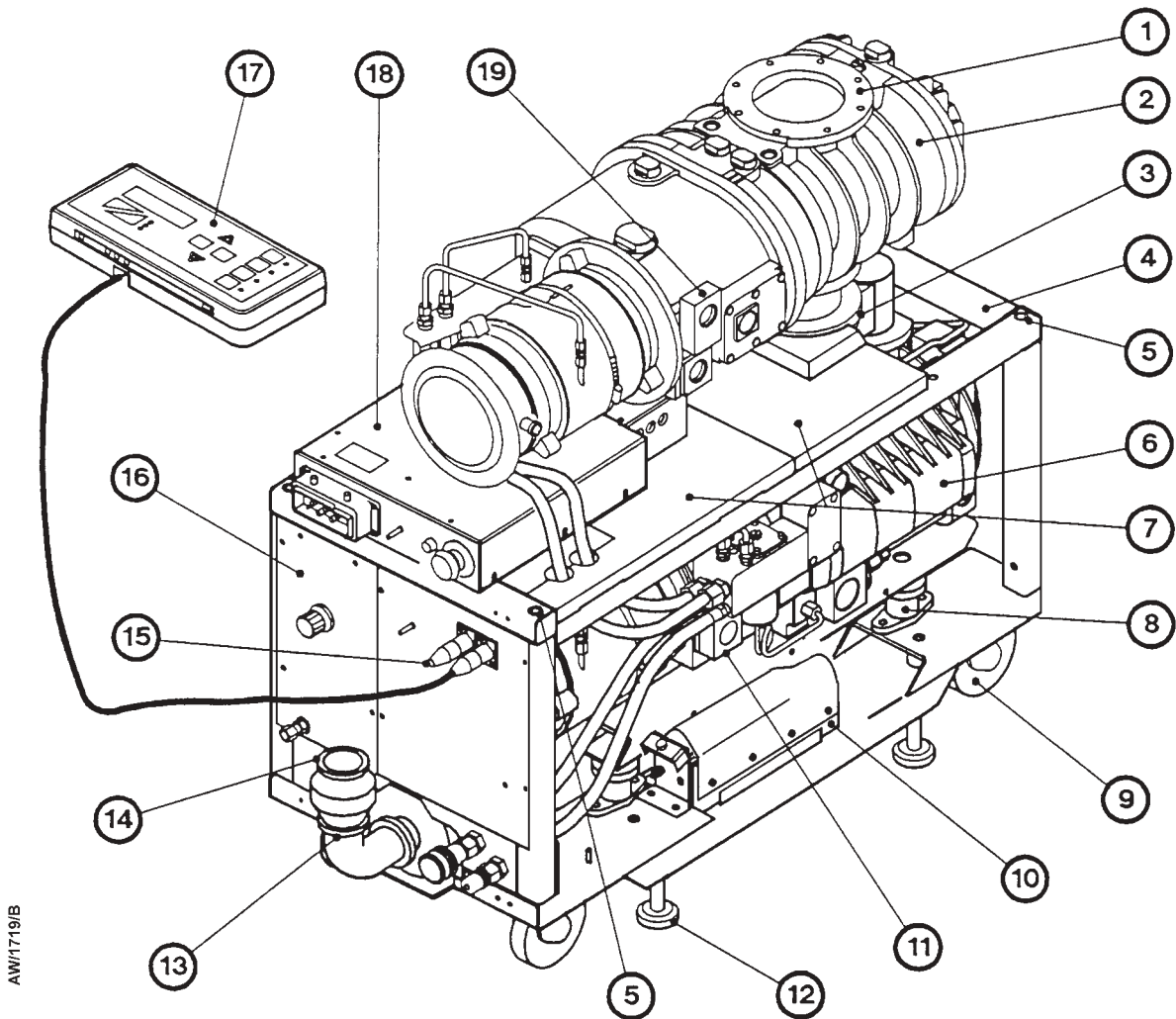

AW/1719/B

- | | | |
|----------------------|---|------------------------------|
| 1. iQMB pump * inlet | 7. Acoustic panels (part of the Acoustic Enclosure *) | 13. Check-valve |
| 2. iQMB pump * | 8. Vibration isolator | 14. Check-valve outlet |
| 3. iQDP pump inlet | 9. Castor | 15. Terminator plug # |
| 4. iQDP pump frame | 10. Sensor Monitoring Module | 16. Gas Module |
| 5. Lifting-bolt hole | 11. iQDP Oil-Level Monitor * | 17. Pump Display Module * |
| 6. iQDP pump | 12. Levelling foot | 18. Electric Module |
| | | 19. iQMB Oil-Level Monitor * |

* Optional components

Only required if you do not fit an Interface Module: refer to Section 3.9

Figure 1-1 - Components of the iQ pumping system
(direct mounted combination pumping system shown)

1.5 The iQDP pump gas system

Note: You must have a Gas Module fitted; you cannot operate the iQ system without a Gas Module.

The iQDP pump has a gas system which allows nitrogen to be delivered to the following points:

- Inlet-purge
- Shaft-seals purges
- 2/3-interstage purge
- 3/4-interstage purge
- Exhaust-purge.

Whether you use all of these purges will depend on the type of Gas Module you have fitted to your iQ system; you should have the type of Gas Module most suitable for your application (see Section 1.6).

1.6 Gas Modules

1.6.1 Introduction

Three types of Gas Module are available for use with the iQ system and these are described in the following sections. Use the type of Gas Module most suitable for your process application.

1.6.2 iQDP Shaft-Seals Purge Module

The Shaft-Seals Purge Module is suitable for use in light duty, clean, non-toxic processes, such as load-lock or sputtering.

The Shaft-Seals Purge Module provides a shaft-seal purge flow of nitrogen to the iQDP pump:

- The purge flow is switched on when the iQDP pump is switched on.
- The purge flow is switched off when the iQDP pump is switched off.

Refer to Figure 1-2 which shows a schematic diagram of the iQ gas system with a Shaft-Seals Purge Module.

The purge flow is switched on or off by the solenoid-valve (21). A pressure gauge (19) on the front panel of the Module (see Figure 3-11) shows the pressure of the shaft-seals purge flow. The pressure is controlled by a pressure regulator (20). A check-valve (18) prevents the flow of process gases back into the Module.

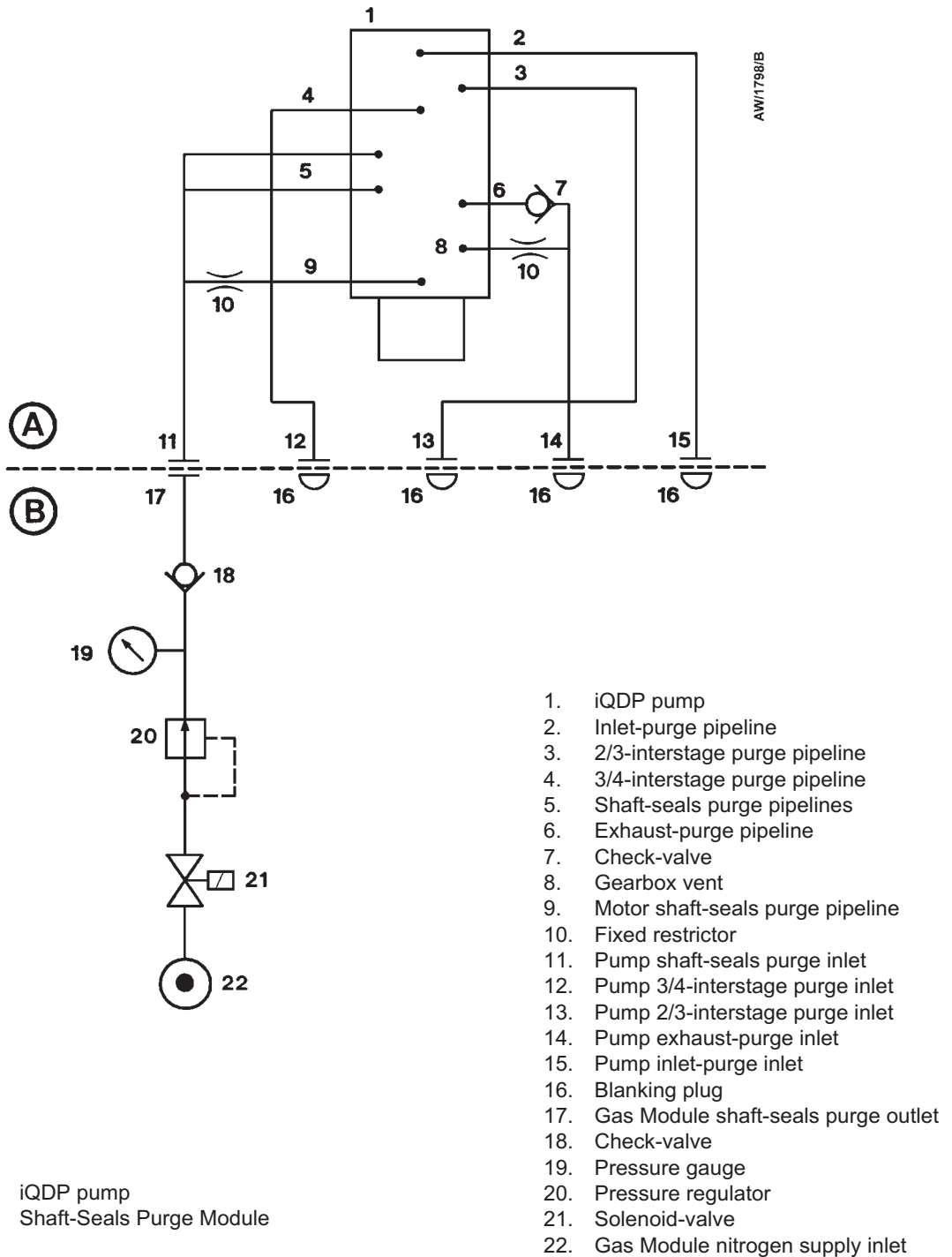

Figure 1-2 - Schematic diagram of the iQ gas system with a Shaft-Seals Purge Module

1.6.3 iQDP Gas-Ballast Module

The Gas-Ballast Module is suitable for use in medium duty processes, such as non-metal etch processes and ashers/ strippers. You can also use the Gas-Ballast Module in light duty processes (see Section 1.6.2).

The Gas-Ballast Module provides the following purge flows to the iQDP pump:

- Shaft-seals purge: this purge flow is on whenever the iQDP pump is on.
- 3/4-interstage purge: this purge flow can be switched on or off by use of the Pump Display Module or by your own control equipment (for example, your process tool or a PC), through one or more optional Interface Modules.

Refer to Figure 1-3 which shows a schematic diagram of the iQ gas system with a Gas-Ballast Module.

The purge flows are switched on or off by the solenoid-valve (24). The purge flow pressure is controlled by a pressure regulator (23). A flow transducer (22) measures the flow of purge gas; the outputs of the transducer are monitored by the iQ system. Check-valves (20, 28) prevent the flow of process gases back into the Module.

The 3/4-interstage purge flow is switched on and off by the solenoid-valve (21). A fixed restrictor (18) limits the 3/4-interstage purge flow rate. If necessary, a service engineer can adjust the variable restrictor (19, supplied fully open) to reduce the 3/4-interstage purge flow rate: contact your nearest Service Centre to arrange this.

A pressure transducer (27) measures the pressure of the shaft-seals purge flow. The outputs of the transducer are monitored by the iQ system.

The front panel has three pressure status LEDs (Figure 3-12, items 1, 2, 8). These LEDs show whether the nitrogen supply pressure is too high, too low or is in the acceptable range: refer to Section 3.22.2.

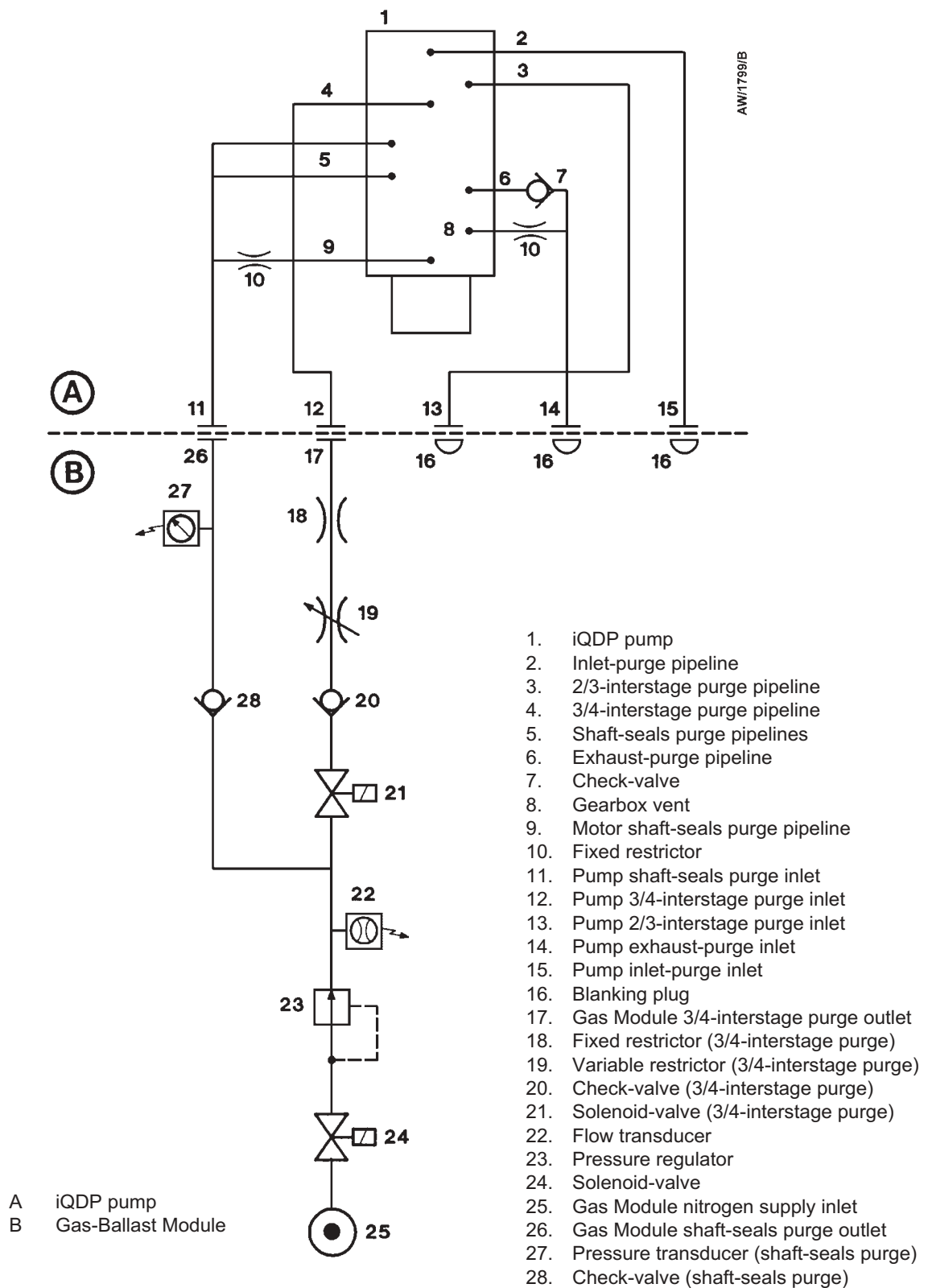

Figure 1-3 - Schematic diagram of the iQ gas system with a Gas-Ballast Module

1.6.4 iQDP Gas System Module Series 2

The Gas System Module Series 2 is suitable for use in harsh processes, such as ion implanters, PECVD (Plasma Enhanced Chemical Vapour Deposition), LPCVD nitride, LPCVD TEOS and Silicides. You can also use the System Module in light or medium duty processes (see Sections 1.6.2 and 1.6.3).

The Gas System Module provides the following purge flows to the iQDP pump:

- Shaft-seals purge: this purge flow is on whenever the iQDP pump is on.
- 2/3-interstage purge and 3/4-interstage purge: these purge flows are either both on or both off. The purge flows can be switched on or off by use of the Pump Display Module or by your own control equipment.
- Exhaust-purge: this purge flow is on whenever the iQDP pump is on.
- Inlet-purge: this purge flow can be switched on or off by use of the Pump Display Module or by your own control equipment.

Note that 'final stage flow' and 'auxiliary flow' can be displayed on the Pump Display Module. These flows are defined as follows:

- Final stage flow = shaft-seals purge flow + 3/4-interstage purge flow.
- Auxiliary flow = 2/3-interstage flow + exhaust-purge flow + inlet-purge flow.

Refer to Figure 1-4 which shows a schematic diagram of the iQ gas system with a Gas System Module Series 2.

The purge flows are switched on or off by the solenoid-valve (41). The purge flow pressure is controlled by a pressure regulator (40). A flow transducer (38) measures the flow of purge gas to the shaft-seals purge and the 3/4-interstage purge. A second flow transducer (39) measures the flow of purge gas to the 2/3-interstage purge, the exhaust-purge and the inlet-purge. A pressure transducer (36) measures the pressure of the shaft-seals purge flow. The outputs of the transducers are monitored by the iQ system. Check-valves (22, 26, 30, 34, 37) prevent the flow of process gases back into the Module.

The 3/4-interstage purge flow is switched on and off by the solenoid-valve (35). A fixed restrictor (32) limits the 3/4-interstage purge flow rate. If necessary, a service engineer can adjust the variable restrictor (33, supplied fully open) to reduce the 3/4-interstage purge flow rate: contact your nearest Service Centre to arrange this.

The 2/3-interstage purge flow is switched on and off by the solenoid-valve (31). A fixed restrictor (28) limits the 2/3-interstage purge flow rate. If necessary, a service engineer can adjust the variable restrictor (29, supplied fully open) to reduce the 2/3-interstage purge flow rate: contact your nearest Service Centre to arrange this.

A fixed restrictor (25) limits the exhaust-purge flow rate. A pressure transducer (27) measures the pressure of the exhaust-purge. The outputs of the transducer are monitored by the iQ system. A pressure-switch (24) monitors the pressure of the exhaust-purge.

(Continued on page 1-10)

The outputs of the pressure-switch are connected directly to the emergency stop circuit of the iQ system: see Section 1.11.3. If there is a slow rate of pressure rise in the exhaust pipeline (for example, caused by a blockage forming due to process debris), the outputs of the pressure transducer will cause the iQ system to be shut down at the appropriate alarm pressure. If the pressure in the exhaust pipeline rises rapidly, the pressure rise may be faster than the response time of the exhaust-purge pressure transducer. In this case, the exhaust pressure-switch will cause the iQ system to be shut down before the pressure transducer output causes shut-down. A rapid pressure rise in the exhaust pipeline may be caused, for example, by the closure of a valve in the exhaust pipeline close to the iQDP exhaust check-valve.

The inlet-purge flow is switched on and off by the solenoid-valve (23). A fixed restrictor (21) limits the inlet-purge flow rate.

The front panel has three pressure status LEDs (Figure 3-12, items 1, 2, 8). These LEDs show whether the nitrogen supply pressure is too high, too low or is in the acceptable range: refer to Section 3.22.2.

1.7 The iQMB mechanical booster pump

The iQMB pumps are positive displacement Roots vacuum pumps. The pump mechanism is driven by a three-phase electric motor through a hydrokinetic fluid-coupling.

The hydrokinetic fluid-coupling is configured so that when the gas-load is high, the rotational speed of the rotors is reduced. As the gas-load decreases, the rotors accelerate to full speed. This allows continuous operation of the pump over the vacuum range without the risk of overloading the motor and removes the need for bypass-valves and associated pipelines.

1. iQDP pump	23. Solenoid-valve (inlet-purge)
2. Inlet-purge pipeline	24. Pressure-switch (exhaust-purge)
3. 2/3-interstage purge pipeline	25. Fixed restrictor (exhaust-purge)
4. 3/4-interstage purge pipeline	26. Check-valve (exhaust-purge)
5. Shaft-seals purge pipelines	27. Pressure transducer (exhaust-purge)
6. Exhaust-purge pipeline	28. Fixed restrictor (2/3-interstage purge)
7. Check-valve	29. Variable restrictor (2/3-interstage purge)
8. Gearbox vent	30. Check-valve (2/3-interstage purge)
9. Motor shaft-seals purge pipeline	31. Solenoid-valve (2/3-interstage purge)
10. Fixed restrictor	32. Fixed restrictor (3/4-interstage purge)
11. Pump shaft-seals purge inlet	33. Variable restrictor (3/4-interstage purge)
12. Pump 3/4-interstage purge inlet	34. Check-valve (3/4-interstage purge)
13. Pump 2/3-interstage purge inlet	35. Solenoid-valve (3/4-interstage purge)
14. Pump exhaust-purge inlet	36. Pressure transducer (shaft-seals purge)
15. Pump inlet-purge inlet	37. Check-valve (shaft-seals purge)
16. Gas Module inlet-purge outlet	38. Flow transducer (shaft-seals purge and 3/4-interstage purge)
17. Gas Module exhaust-purge outlet	39. Flow transducer (inlet-purge, 2/3-interstage purge and exhaust-purge)
18. Gas Module 2/3-interstage purge outlet	40. Pressure regulator
19. Gas Module 3/4-interstage purge outlet	41. Solenoid-valve
20. Gas Module shaft-seals purge outlet	42. Gas Module nitrogen supply inlet
21. Fixed restrictor (inlet-purge)	43. Snubber
22. Check-valve (inlet-purge)	

Figure 1-4 - Schematic diagram of the iQ gas system with a Gas System Module Series 2: key

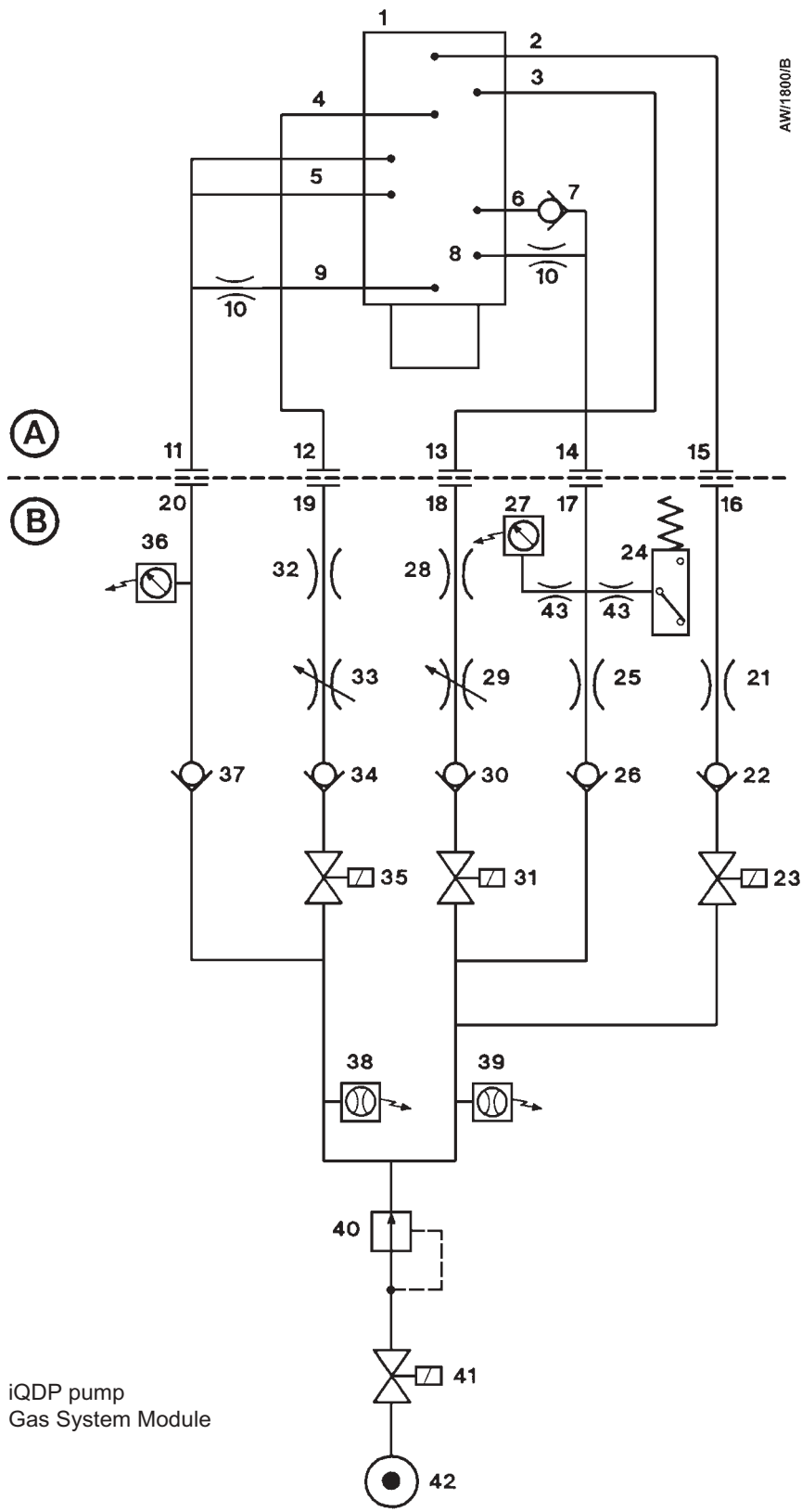

Figure 1-4 - Schematic diagram of the iQ gas system with a Gas System Module Series 2

1.8 Temperature control system

1.8.1 iQDP pump temperature control system

The low vacuum stage of the iQDP pump has an indirect cooling system, all other stages are air-cooled by natural convection and radiation. In the secondary circuit of the indirect cooling system, coolant circulates around the pump-body by natural convection. In the primary circuit, cooling-water is circulated through copper coils to extract heat from the coolant. In operation, the pump is maintained at a constant temperature by a TCV (thermostatic control-valve) which controls the supply of cooling-water to the primary circuit in the pump.

The pump-motor is cooled by water flowing through a cooling jacket which surrounds the motor. The pump-motor cooling circuit is separate from the pump cooling circuit. The cooling-water supply and return pipelines are connected to the pump by connectors on the end of the iQ system (see Figure 1-5).

The cooling-water manifold on the pump distributes the cooling-water to the pump cooling circuit and to the pump-motor cooling circuit (and to the iQMB pump-motor cooling circuit, if an iQMB pump is fitted). When an iQMB pump is not fitted, the flow of cooling-water to the iQDP pump-motor is greater than the minimum required flow. When an iQMB pump is fitted, the cooling-water flow is distributed equally between the two pump-motors and the overall flow requirement for the pumping combination increases.

A thermocouple is fitted to the pump-body to measure the temperature of the pump-body. The output of the thermocouple is monitored by the Sensor Monitoring Module: see Section 1.10.3.

For safety purposes, a thermal snap-switch is fitted to the pump-body. The thermal snap-switch opens at 150 °C. The output of the thermal snap-switch is connected to the internal emergency stop circuit and will shut down the iQ system if the snap-switch has operated and the normal temperature monitoring system has not already shut down the iQ system.

Three motor-protection thermistors are fitted to the pump-motor (one on each winding). These thermistors are solid-state devices which have an electrical resistance of 100 to 500 Ω at normal pump-motor operational temperature. When the pump-motor is too hot, the electrical resistance rises quickly to 3000 Ω. The thermistors are connected in series and the outputs of the thermistors are connected to the emergency stop circuit to shut down the iQ system if the pump-motor is too hot.

A surface temperature sensor (Figure 3-4, item 15) is fitted to the pump-motor. The output of the sensor is monitored by the Sensor Monitoring Module and is used to provide a warning of cooling system failure.

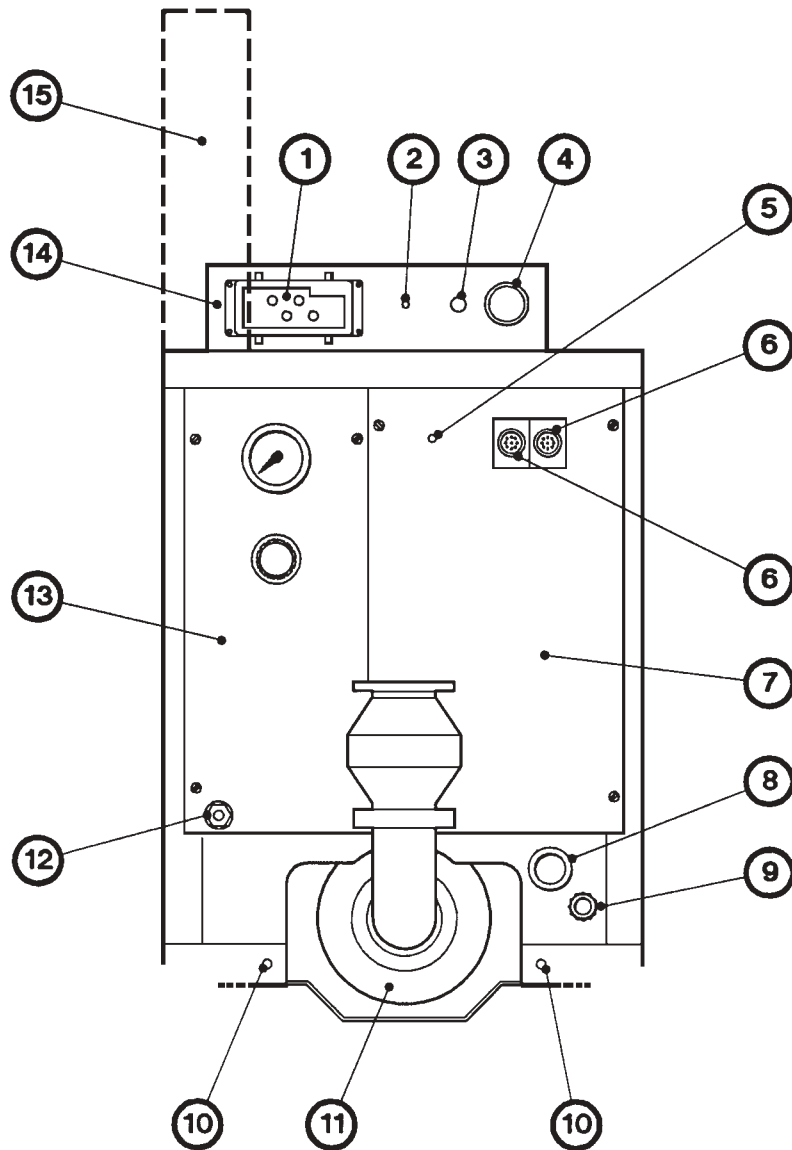

AW1782/A

- | | |
|-----------------------------------|---|
| 1. Electrical supply connector | 9. Cooling-water supply connector |
| 2. Earth (ground) stud | 10. Exhaust support-plate fixing screw |
| 3. Power on lamp | 11. Exhaust-silencer |
| 4. Emergency stop switch | 12. Gas Module nitrogen inlet |
| 5. RF earth (ground) stud | 13. Gas Module (Shaft-Seals Purge Module shown) |
| 6. Module connector | 14. Electrics Module (horizontally mounted) * |
| 7. Front panel | 15. Electrics Module (vertically mounted) * |
| 8. Cooling-water return connector | |

* See Section 1.10.2.

Figure 1-5 - Services connections

1.8.2 iQMB pump temperature control system

The iQMB250F and iQMB500F pumps are cooled by ambient air and the iQMB1200F pump is water-cooled. All the iQMB pumps have enclosed, water-cooled motors.

The cooling-water supply and return pipes are connected to quick-fit connectors on the pump-motor (see Figure 3-2); the other ends of the pipes are connected to the cooling-water manifold on the iQDP pump.

On the iQMB250F and iQMB500F pumps, the cooling-water passes through the pump-motor cooling circuit, then returns to the iQDP cooling-water manifold. On the iQMB1200F pump, the cooling-water passes through the pump cooling circuit, then through the pump-motor cooling circuit, then returns to the iQDP cooling-water manifold.

Three motor-protection thermistors are fitted to the pump-motor (one on each winding). These thermistors are identical to those fitted to the iQDP pump (see Section 1.8.1). The thermistors are connected in series and the outputs of the thermistors are connected to the emergency stop circuit to shut down the iQ system if the pump-motor is too hot.

A surface temperature sensor (Figure 3-2, item 15) is fitted to the pump-motor. The output of the sensor is monitored by the Sensor Monitoring Module and is used to provide a warning of cooling system failure.

1.9 Exhaust system

The outlet of the iQDP pump is connected to an exhaust-silencer, which is below the pump. The outlet also has a port which allows gearbox vent gases to join the main exhaust stream (see Figures 1-2 to 1-4). The exhaust-silencer attenuates the pulses in the exhaust pressure and reduces pump-induced resonance in your exhaust-extraction system.

The outlet of the exhaust-silencer has a check-valve which prevents the suck-back of exhaust vapours after the pump is shut down. The valve also provides additional attenuation of the pulses in the exhaust pressure.

1.10 Electrical system

Refer to Figure 1-6 which shows a schematic diagram of the electrical and control system of the iQ system.

1.10.1 Introduction

Notes: Figure 1-6 shows the Sensor Monitoring Module PCA (Printed Circuit Assembly) and the Electrics Module control PCA as separate functional blocks. Physically, however, the Electrics Module control PCA is inside the Sensor Monitoring Module enclosure.

The Sensor Monitoring Module PCA and Electrics Module PCA service buttons are only used if your iQ system is on a network: refer to the manual(s) supplied with the network and monitoring software for more information.

The iQ system has an Electrics Module (37), a Sensor Monitoring Module (35) and a Gas Module (36). Optionally, your iQ system may have a Pump Display Module (3), an iQ Interface Module (1), an iQMB pump and other accessories, such as oil-level monitors.

The Sensor Monitoring Module (and the Electrics Module control PCA), the iQ Interface Module and the Pump Display Module communicate through a serial data network. If you have a Gas-Ballast Module or a Gas System Module, these will also be on the network.

Each Module on the network has a microprocessor. The microprocessor controls the network communications and also contains the default setpoints for the sensors in or connected to the Modules (see Section 2).

1.10.2 Electrics Module

Notes: The Electrics Module is usually mounted horizontally on the front of the iQDP pump frame (as shown in Figure 1-5, item 14). On iQDP40/iQMB250F direct mounted combination iQ systems, the Electrics Module can also be mounted vertically at the side of the iQMB pump-motor (as shown in Figure 1-5, item 15): see Section 8.4.3 for more information.

The operation of a safety sensor will have the same effect as the operation of the emergency stop switch: see Section 1.11.3.

Refer to Figure 1-6. The external electrical supply (8) is connected to the electrical supply connector (9) on the Electrics Module (37). The Electrics Module provides the electrical supplies to the iQDP pump, to the Gas Module and to the iQMB pump (if fitted).

The Electrics Module has contactors for the iQDP and iQMB pumps, pump power and current consumption sensors and short-circuit protection. Internal clocks and counters in the Electrics Module measure the operating time of the iQ system and keep count of the number of iQ system switch-on/switch-off and process cycles. The Electrics Module also has a transformer and fuses for the 24 V control circuits and fuses for the following supplies: Gas Module (18), iQ Interface Module (19) and external emergency stop circuit (20).

(Continued on page 1-18)

1. iQ Interface Module *
2. Remote Display Module *
3. Pump Display Module *
4. Pump Display Module connector
5. iQ Interface Module connector
6. Earth (ground) stud
7. Emergency stop switch
8. External electrical supply
9. Electrical supply connector
10. iQDP pump electrical supply
11. iQDP pump motor terminal-box
12. iQDP pump thermistors cable
13. iQMB pump * electrical supply
14. iQMB pump * motor terminal-box
15. iQMB pump * thermistors cable
16. iQMB thermistors cable connector
17. iQMB electrical supply connector
18. Gas Module fuse holder
19. iQ Interface Module fuse holder
20. External emergency stop circuit fuse holder
21. External emergency stop connector
22. Gas Module electrical supply connector
23. iQ Interface Module/external EM loop
24. Internal emergency stop loop
25. Pump shut-down thermal snap-switch
26. Water flow-switch *
27. Electrics Module control PCA
28. iQDP pump oil-level monitor *
29. iQMB pump oil-level monitor *
30. iQDP pump-body temperature sensor
31. iQDP pump-motor temperature sensor
32. Exhaust temperature sensor *
33. iQMB pump * motor temperature sensor
34. Gas module electrical supply
35. Sensor Monitoring Module
36. Gas Module
37. Electrics Module
38. 25-way 'D' type connector
39. Electrical supply and control signals
40. RJ45 connector
41. Pressure sensor (Gas-Ballast and Gas System Modules)
42. Flow sensor
43. Pressure-switch
44. Solenoid-valves
45. Front panel of the iQDP pump frame
46. Sensor Monitoring Module enclosure
47. RF earth (ground) stud

* Optional components

Figure 1-6 - Schematic diagram of the electrical system: key

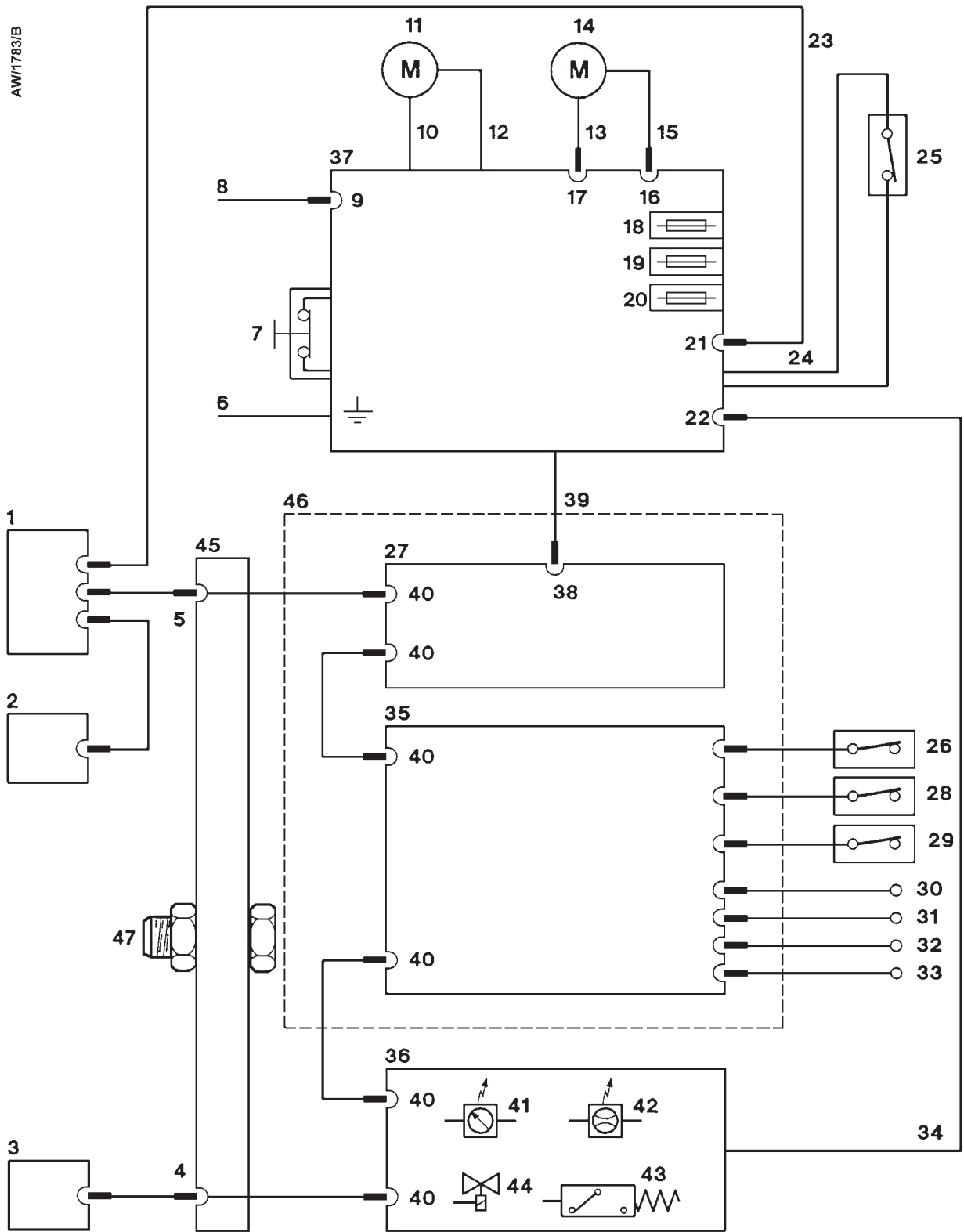

Figure 1-6 - Schematic diagram of the electrical system

Two thermal-type fuses (FS6 and FS8) in the Electrics Module protect the d.c. electrical supplies to the network. If one of these fuses has tripped, it must be reset before you can continue to operate the iQ: refer to Table 6-2.

Refer to Figure 1-5. The front panel of the Electrics Module has the following controls, lamp and connections:

Emergency stop switch (4)	Press this to immediately shut down the iQ system in an emergency: refer to Section 5.12.
Power on lamp (3)	This lamp is on when the electrical supply to the Electrics Module is on.
Electrical supply connector (1)	Use this connector to connect your external electrical supply to the iQ system: refer to Section 3.19.
Earth (ground) stud (2)	If required, use this to make additional earth (ground) connections: refer to Section 3.19.

Refer to Figure 1-7, detail A. The side panel of the Electrics Module has fuse holders for the iQ Interface Module (1), the emergency stop circuit (2) and the Gas Module (3). Refer to Figure 1-7, detail B. The rear panel of the Electrics Module has the following connectors:

External emergency stop connector (11)	Use this connector to connect an external emergency stop circuit from your control equipment (or an iQ Interface Module) to the iQ system.
iQMB thermistors connector (9)	Use this connector to connect the output of the thermistors in the iQMB pump (if fitted) to the Electrics Module.
Gas Module electrical supply connector (7)	Use this cable to connect the electrical supply from the Electrics Module to the Gas Module.
Emergency stop cable (4)	This cable connects the safety sensors to the internal emergency stop circuit: see Section 1.11.3.
iQDP thermistors cable (8)	This cable is used to connect the output of the thermistors in the iQDP pump to the Electrics Module.
GRC bypass connector (5)	If required, use this connector to connect the iQ system to a BOC Edwards GRC: see Section 3.18.
iQMB electrical supply connector (6)	Use this to connect the electrical supply from the Electrics Module to the iQMB pump (if fitted).
Earth (ground) stud (10)	This stud is used to earth (ground) components in the iQ system.

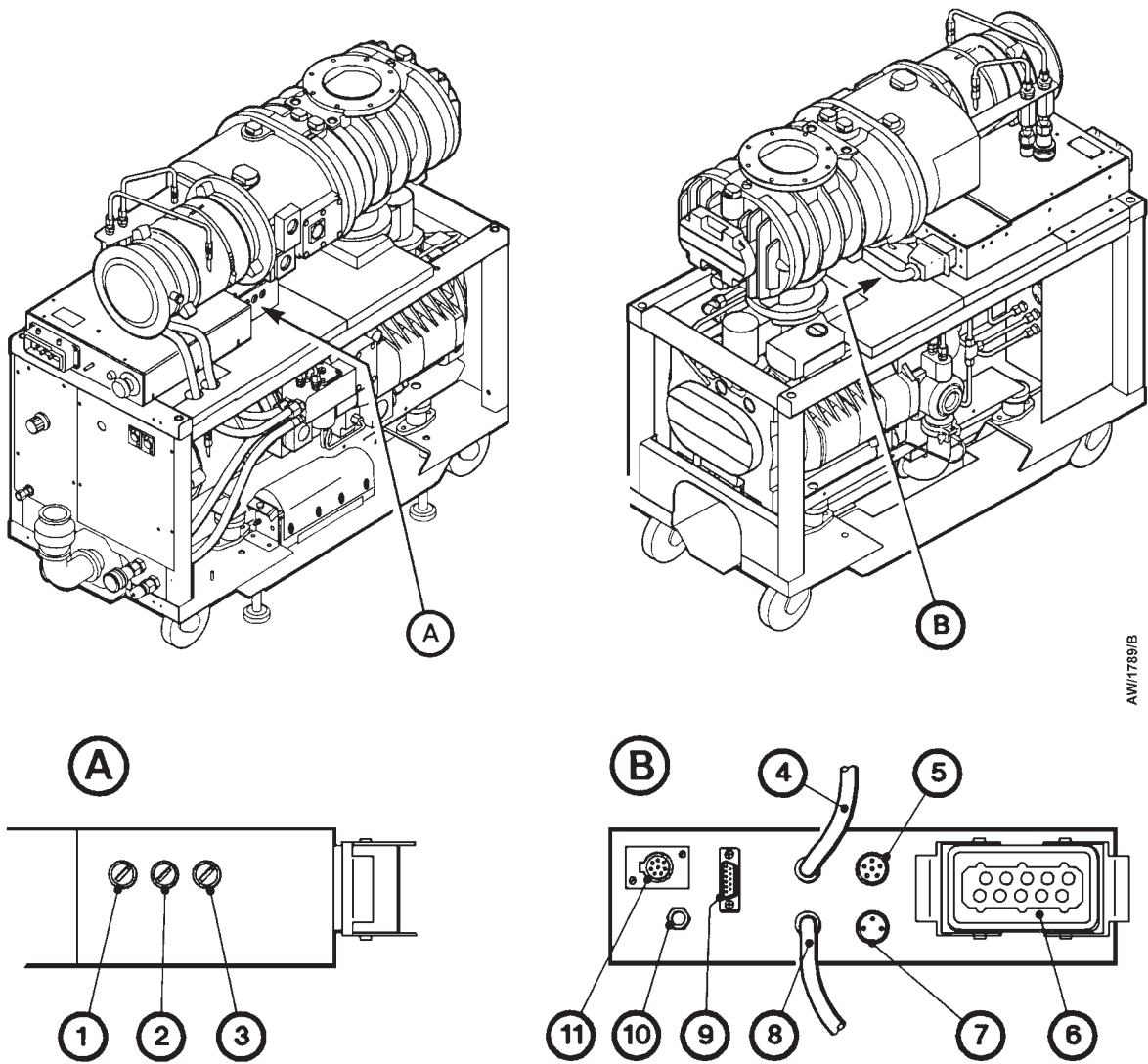

AW1789/B

- | | |
|--|---|
| 1. iQ Interface Module fuse holder (F8) | 6. iQMB electrical supply connector |
| 2. Emergency stop circuit fuse holder (F9) | 7. Gas Module electrical supply connector |
| 3. Gas Module fuse holder (F7) | 8. iQDP thermistors cable |
| 4. Emergency stop cable | 9. iQMB thermistors connector |
| 5. GRC bypass connector | 10. Earth (ground) stud |
| | 11. External emergency stop connector |

Figure 1-7 - Side and rear panels of the Electrics Module

1.10.3 Sensor Monitoring Module

The Sensor Monitoring Module communicates (through the network) with the Gas Module, the optional Pump Display Module and the optional Interface Module accessories. The following sensors are connected to the Sensor Monitoring Module:

- iQDP pump-body and pump-motor temperature sensors
- iQMB pump-motor temperature sensor (if an iQMB pump is fitted)
- Exhaust temperature sensor (if fitted)
- iQDP and iQMB pump oil-level monitors (if fitted)
- Water flow-switch (if fitted)

The Sensor Monitoring Module has a microprocessor which:

- Monitors the status of the system.
- Sends warning and alarm messages (see Section 1.11.2) to other Modules connected to the iQ system.
- Monitors the control inputs (from the Pump Display Module or the Interface Module accessories) and switches the pumps on and off as requested.
- Shuts down the iQ system if a sensor reading is outside the specified alarm range: see Section 1.11.2. (Note that the safety sensors can also shut down the iQ system; these sensors are not connected to the microprocessor: see Section 1.11.3.)

The Sensor Monitoring Module has four network connectors to which replaceable Modules (such as the Gas Module) and optional Modules are connected. Figure 1-8 shows the connectors on the top panel of the Sensor Monitoring Module.

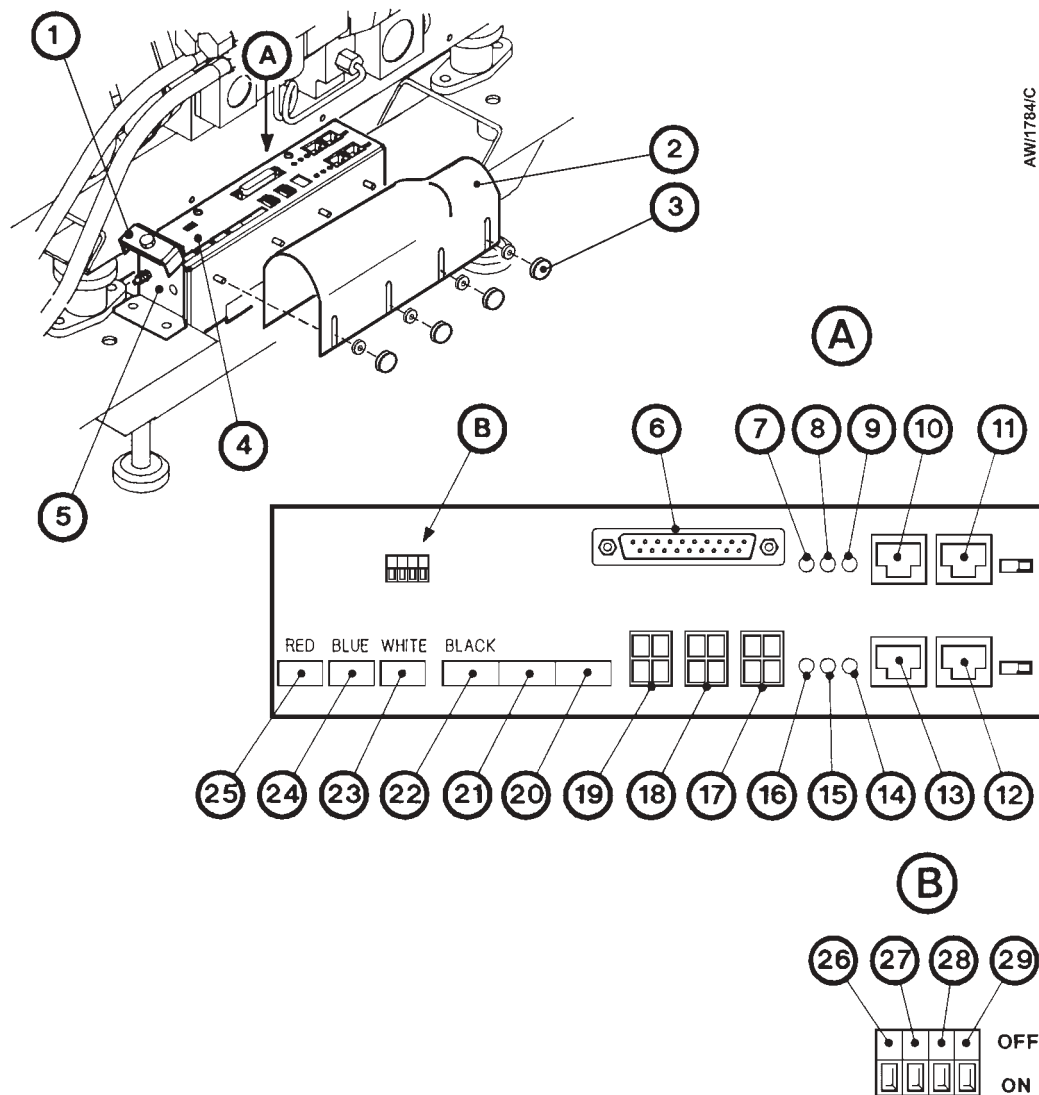

AW/1784/C

- | | | |
|-------------------------------|--|---|
| 1. Earthing (grounding) clamp | 13. Network connector A | 23. Exhaust temperature sensor connector |
| 2. Cover | 14. Service LED # | 24. iQDP motor temperature sensor connector |
| 3. Thumbwheel | 15. Service button # | 25. iQMB motor temperature sensor connector |
| 4. Sensor Monitoring Module | 16. Default button # | 26. DIP switch 1 † |
| 5. Support bracket | 17. Water Flow Sensor connector | 27. DIP switch 2 † |
| 6. Electrics Module connector | 18. iQDP Oil-Level Monitor connector | 28. DIP switch 3 † |
| 7. Default button * | 19. iQMB Oil-Level Monitor connector | 29. DIP switch 4 † |
| 8. Service button * | 20. Spare connector | |
| 9. Service LED * | 21. Spare connector | |
| 10. Network connector D | 22. Pump-body temperature sensor connector | |
| 11. Network connector C | | |
| 12. Network connector B | | |

* Electrics Module PCA
Sensor Monitoring Module PCA

† Refer to Section 3.6 for the DIP switch settings

Figure 1-8 - Top panel of the Sensor Monitoring Module

1.11 Control functions

1.11.1 Priority of control

The iQ system can be controlled by a number of modules: the Pump Display Module (see Section 1.12); an iQ Interface Module (see Section 1.13); or the iQ Single Pumpset Monitor (see Section 1.14). Only one module can have control of the iQ system at any one time. That is, once a module has control of the iQ system, control requests from another Module are denied.

To allow another Module to control the iQ system:

- The Module which currently has control must 'release' control (that is, you must send the appropriate message on the network or press the appropriate button to release control).
- Any Module which requires control must then 'take' control (that is, you must send the appropriate message to the iQ system or press the appropriate button to take control).

Note that when you first switch-on the electrical supply, no Module will initially have control of the iQ system. The Module which you want to control the iQ system must take control as described above.

1.11.2 Setpoints, warning and alarm conditions

Each Module which monitors sensors has a microprocessor. Each monitored sensor (except for switch-type sensors, such as the oil-level monitors, which have only two output states: error or no error) has four associated setpoints. The setpoints are: the low warning setpoint, the high warning setpoint, the low alarm setpoint and the high alarm setpoint. The microprocessor compares the sensor data to the setpoints to determine if an alarm or warning condition exists:

- If the sensor data is below the low warning setpoint or above the high warning setpoint, a warning condition exists. A warning condition means that some aspect of the operation of the iQ system is abnormal. The iQ system will continue to operate.
- If the sensor data is below the low alarm setpoint or above the high alarm setpoint, an alarm condition exists. An alarm condition means there is a serious fault which results in the shut-down of the iQ system to prevent damage to the iQ system. However, note that for some of the alarm conditions, you may be able to continue to operate the iQ system if you have configured the iQ system to 'run til crash': see Section 5.11.

If an alarm or warning condition exists, an appropriate alarm or warning message is displayed on the Pump Display Module (if fitted) and an appropriate alarm or warning indication is sent to other Modules on the network. Refer to Section 6 for a full list of the Pump Display Module warning and alarm messages.

You can use the default setpoints or you can adjust the setpoints to suit your application: refer to Section 5.3. At any time (that is, even after you have adjusted the setpoints), you can request that the default setpoints are used: refer to Section 5.3. Refer to Section 2 for the default setpoints.

1.11.3 Safety sensors

Note: The operation of a safety sensor will have the same effect as the operation of the emergency stop switch described in Section 1.10.2.

The iQ system has a number of safety sensors connected to the internal emergency stop circuit in the Electrics Module. If any of the safety sensors operate, the iQ system is immediately shut down. Table 1-1 shows the safety sensors and the shut-down conditions.

Safety sensor	Shut-down condition
iQDP pump-motor thermistors	When the thermistors in the iQDP pump-motor indicate that the temperature of the pump-motor is 160 °C or higher.
iQMB pump-motor thermistors	When the thermistors in the iQMB pump-motor indicate that the temperature of the pump-motor is 160 °C or higher.
iQDP pump shut-down thermal snap-switch	When the thermal snap-switch operates to indicate that the temperature of the iQDP pump-body is 150 °C or higher.
Exhaust pressure-switch (Gas System Module only)	When the pressure-switch operates to indicate that the pressure in the exhaust pipeline is 9 psig or higher.

Table 1-1 - Safety sensors

1.12 Pump Display Module accessory

The optional Pump Display Module accessory allows you to manually control the iQ system and to display the status of the iQ system. Refer to Figure 1-9 which shows the front panel of the Pump Display Module.

Use the On button (10) to switch on the iQ system (refer to Section 5.6). The On button has a LED which is on when the iQ system is on. Use the Off button (9) to switch off the iQ system (refer to Section 5.10).

The display (1) shows two lines of text; each line is 16 characters long. In normal operation, the Normal display is shown; the Normal display has two pages, and each page has two lines. Each page of the Normal display shows the current status of one or more iQ system sensors or internal clocks and counters. As supplied the first page of Normal display shows iQDP pump power consumption and iQDP pump body temperature, and the second page shows iQMB pump power consumption and iQMB pump-motor temperature. You can change the information shown on the Normal display: refer to Section 5.4.

At any time, you can press one of the four menu buttons (4) to select a new menu. You can then use the up (2), down (6), ENTER (3) and CANCEL (7) buttons to move through the menu. The appropriate menu selected LED (5) is on when the corresponding menu is in use.

(Continued on page 1-24)

Note: The service button is only used if your iQ system is on a network: refer to the manual(s) supplied with your network and monitoring software

Use the menu (4), up (2), down (6), CANCEL (7) and ENTER (3) buttons as described below. Refer to Section 4 for a full definition of the menu structures and the display formats.

Normal	Press this button to select the Normal display (see above).
Control	Press this button to select the Control menu. You can then take control or release control of the pumping system (see Section 5.5).
Status	Press this button to select the Status menu. In this menu, you can display the current values of all iQ system sensors.
Setup	Press this button to select the Setup menu. In this menu you can: manually control the operation of iQ gas purges and a gate valve fitted to the vacuum system (and connected to the iQ through an iQ Interface Module with an Auxiliary Interface Card); select 'Run til Crash'; adjust the setpoints; change other display parameters (such as the pressure units used when pressures are displayed and the timeout time). The Setup menu also allows you to select the Service menu; in this menu, you can change service information (such as pumping system and pump serial numbers) and manually operate the components of the iQ system.
ENTER	Use this button to select a currently displayed menu option or to enter a currently displayed parameter.
CANCEL	Use this button to cancel the currently displayed menu or option and return to the previous menu or option.
Up/down	Use these buttons to move up or down menu options or to increase or decrease a displayed parameter.

The status LEDs (8) show the current status of the iQ system and the Pump Display Module:

ALARM	This LED shows when an alarm condition exists.
WARNING	This LED shows when a warning condition exists.
LOCAL CONTROL	This LED is on when the Pump Display Module has control of the iQ system.

The ALARM and WARNING LEDs flash when the corresponding alarm or warning condition first occurs. When you acknowledge the condition (refer to Section 5), the corresponding LED goes on permanently. For most alarms and warnings, if the condition clears (that is, the fault which caused the condition is no longer present), the corresponding LED goes off; see Tables 6-2 and 6-3 for the alarms and warnings whose LEDs do not automatically reset in this way.

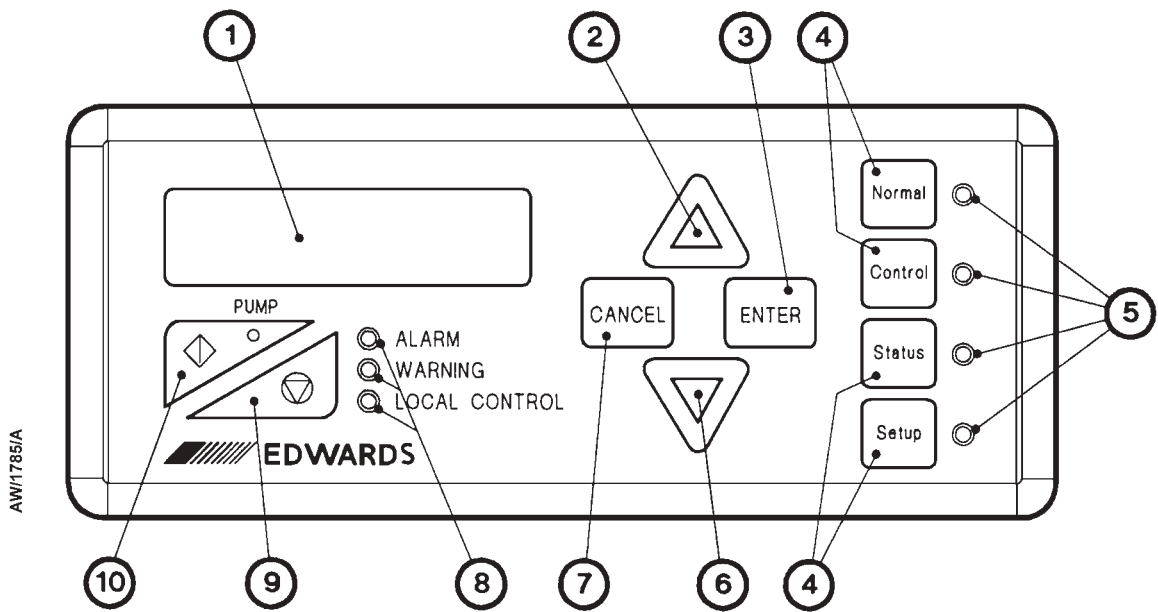

- | | |
|-----------------------|------------------|
| 1. Display | 6. Down button |
| 2. Up button | 7. CANCEL button |
| 3. ENTER button | 8. Status LEDs |
| 4. Menu buttons | 9. Off button |
| 5. Menu selected LEDs | 10. On button |

Figure 1-9 - Front panel of the Pump Display Module

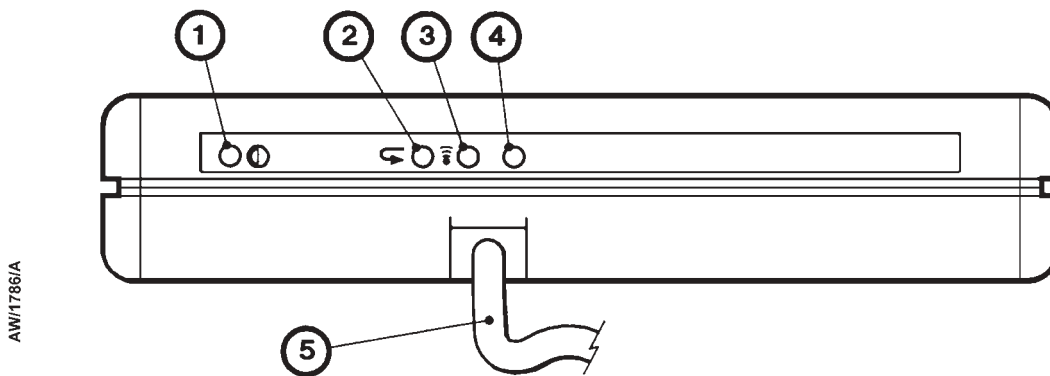

- | | |
|-----------------------------------|--------------------|
| 1. Display viewing angle adjuster | 4. Service LED |
| 2. Default setpoint button | 5. Connector cable |
| 3. Service button | |

Figure 1-10 - Bottom panel of the Pump Display Module

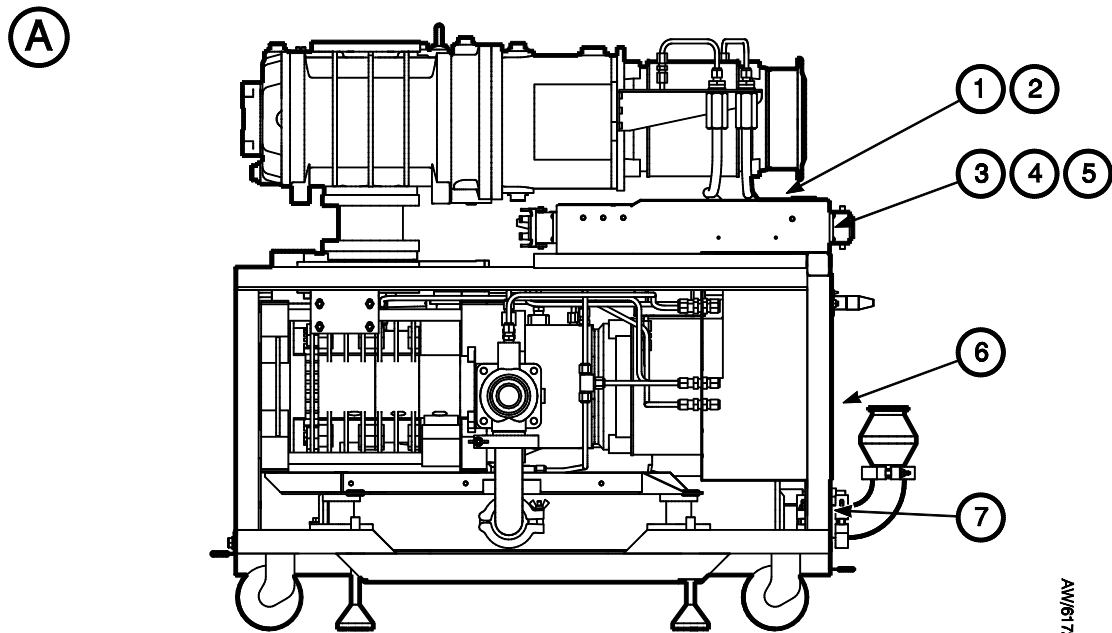

AV/6172/A

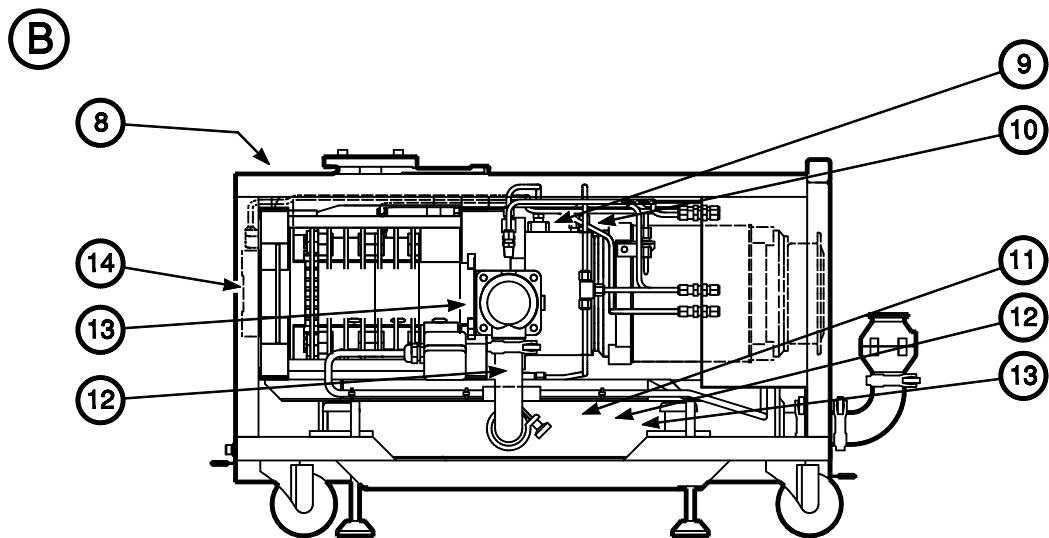

- | | |
|-----|--|
| A | General view of the iQ system |
| B | Detail view of the iQDP pump (iQMB pump not shown) |
| 1. | 'Warning - Risk of electric shock label |
| 2. | 'Warning - Disconnect mains power before removing cover' label |
| 3. | Protective earth (ground) symbol label |
| 4. | PE external earth (ground) conductor symbol label |
| 5. | AC mains power (electrical supply) symbol label |
| 6. | iQ system information label |
| 7. | Nitrogen inlet label |
| 8. | 'Caution - Maximum lifting angle 60°' label |
| 9. | 'Caution - Do not overfill with oil label |
| 10. | 'Use only Fomblin Y25 or Krytox 1525 oil label |
| 11. | Direction of gas flow arrow label |
| 12. | Caution symbol label |
| 13. | 'Warning - Risk of high temperature' label |
| 14. | iQDP information/Warning - Risk of high temperature' label |

Figure 1-11 - Labels on the iQ system: page 1 of 2

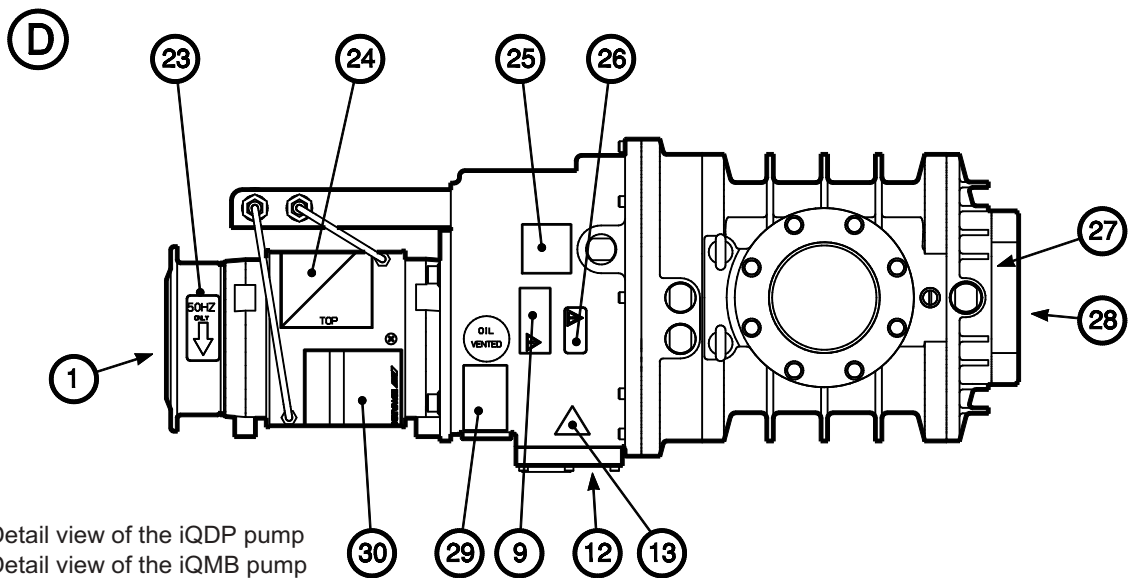
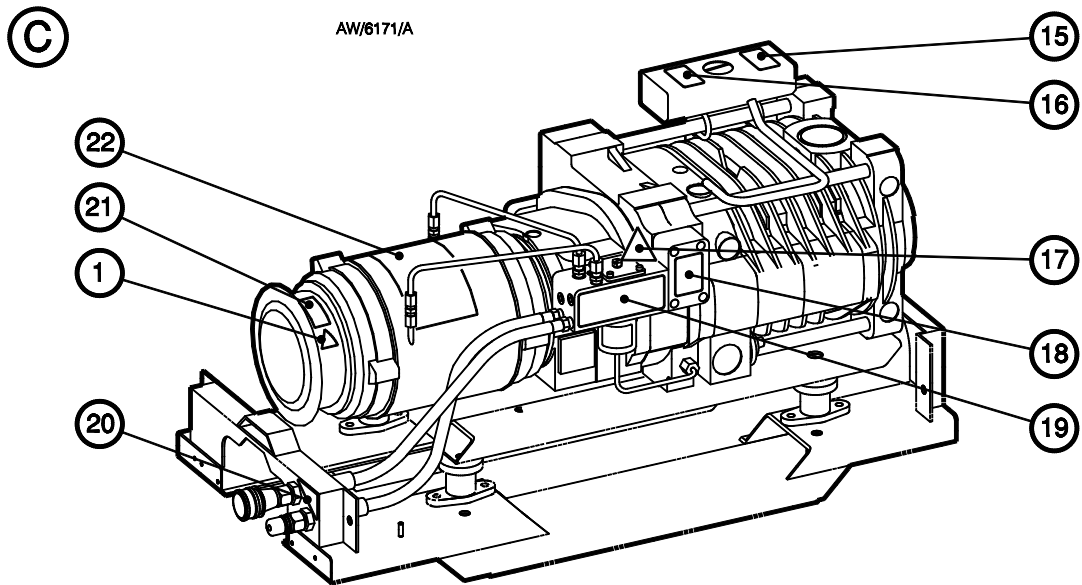

C Detail view of the iQDP pump
 D Detail view of the iQMB pump

- | | |
|---|---|
| <ul style="list-style-type: none"> 15. 'Caution - For safe operation, this equipment must be installed, operated and maintained in accordance with the instruction manual label 16. 'Caution - Do not overfill with coolant label 17. 'Caution - Valve is factory preset label 18. 'Caution - Read instruction manual before adjusting valve' label 19. 'Supply In/Out/Bleed air: lift label 20. 'Water In/Out' label 21. Direction of rotation arrow label 22. iQDP motor rating information label | <ul style="list-style-type: none"> 23. Direction of rotation arrow/frequency label 24. 'Do not step on/Motor damage' label 25. 'Coupling cover filler plug/Oil level lower sight glass' label 26. 'Use only FomblinY16/6 or Krytox 1514 oil label 27. 'Regrease bearings in accordance with instruction manual' label 28. iQMB information/Warning - Risk of high temperature' label 29. 'Use vented plug only/Shaft seal reservoir label 30. iQMB motor rating information label |
|---|---|

Figure 1-11 - Labels on the iQ system: page 2 of 2

1.13 iQ Interface Module accessories

The iQ Interface Module accessory allows you to control the operation of the iQ system through your process tool or other control equipment.

The iQ Interface Module can contain one or more Tool Interface Cards and/or one or more Auxiliary Interface Cards:

- A Tool Interface Card allows you to use your process tool to control the operation of and to monitor the status of the iQ system.
- An Auxiliary Interface Card allows you to control the operation of other equipment (such as a gate valve) connected to the iQ system.

1.14 iQ PC Interface Kit accessory

The iQ PC Interface Kit allows you to use a PC to switch the iQ system on and off and to monitor the status of the iQ system. Refer to Section 8 for more information.

1.15 iQ Central Monitoring System

The iQ Central Monitoring System allows you to monitor all of the iQ systems in your installation. Refer to Section 8 for more information.

1.16 Labels

Labels are fitted to the iQ system in order to:

- Identify components.
- Define required installation/operating/maintenance procedures.
- Identify safety hazards.

Refer to Figure 1-11 which shows the labels fitted to the iQ system.

2 TECHNICAL DATA

Notes: Unless otherwise specified, data in the following sections applies to all models of iQ system.

Figures 2-1 to 2-4 show the dimensions of iQ systems without acoustic enclosures. Refer to the Acoustic Enclosure instruction manual for dimensions of iQ systems with acoustic enclosures.

2.1 General

Dimensions	See Figures 2-1 to 2-4	
Warm-up time to nominal performance	15 min	
Vacuum system maximum leak-rate	1×10^{-5} mbar l s ⁻¹ (1×10^{-3} Pa l s ⁻¹)	
Exhaust system maximum leak-rate	1×10^{-5} mbar l s ⁻¹ (1×10^{-3} Pa l s ⁻¹)	
Ambient operating temperature range	5 to 40 °C	
Maximum ambient operating humidity	90% RH	
Noise level	< 70 dB(A) *	
Mass		
iQDP40 system	186 kg	
iQDP80 system	216 kg	
	Direct mounted	Frame mounted
iQDP40/iQMB250 system	256 kg	313 kg
iQDP40/iQMB500 system	269 kg	329 kg
iQDP80/iQMB250 system	286 kg	346 kg
iQDP80/iQMB500 system	299 kg	359 kg
iQDP80/iQMB1200 system	-	450 kg

2.2 Performance

Pumping speed range	See Figures 2-5 to 2-10
Power curves	See Figures 2-11 to 2-15
Peak pumping speed	See Table 2-1
Ultimate vacuum	See Table 2-1
Displacement (swept volume)	See Table 2-1

2.3 Cooling-water supply

Maximum supply pressure	100 psig (6.9 bar, 6.9×10^5 Pa)
Minimum required pressure differential across supply and return	30 psi (2.1 bar, 2.1×10^5 Pa)
Typical heat removed from iQDP pump	1.75 kW (iQDP40), 2.75 kW (iQDP80)
Water consumption	See Table 2-2
Maximum particle size in supply	0.03 mm ²

* iQDP40 and iQDP80 pumps, measured at 1 metre from the pump.

iQ system →			iQDP40	iQDP80	iQDP40/ iQMB250	iQDP40/ iQMB500	iQDP80/ iQMB250	iQDP80/ iQMB500	iQDP80/ iQMB1200
Parameter		Units							
Typical peak pumping speed	50 Hz	m ³ h ⁻¹	44	80	235	350	260	390	815
	60 Hz	m ³ h ⁻¹	55	96	290	425	305	460	940
Displacement (swept volume)	50 Hz	m ³ h ⁻¹	52.0	91.5	310	505	310	505	1195
	60 Hz	m ³ h ⁻¹	62.4	109.8	375	605	375	605	1435
Typical ultimate vacuum with shaft-seals purge only	50 Hz	mbar	5 × 10 ⁻²	3 × 10 ⁻²	2.5 × 10 ⁻³	2.5 × 10 ⁻³	2.0 × 10 ⁻³	2.0 × 10 ⁻³	2.0 × 10 ⁻³
		Pa	5	3	2.5 × 10 ⁻¹	2.5 × 10 ⁻¹	2.0 × 10 ⁻¹	2.0 × 10 ⁻¹	2.0 × 10 ⁻¹
	60 Hz	mbar	3 × 10 ⁻²	1 × 10 ⁻²	2.0 × 10 ⁻³	2.0 × 10 ⁻³	7.0 × 10 ⁻⁴	7.0 × 10 ⁻⁴	7.0 × 10 ⁻⁴
		Pa	3	1	2.0 × 10 ⁻¹	2.0 × 10 ⁻¹	7.0 × 10 ⁻²	7.0 × 10 ⁻²	7.0 × 10 ⁻²
Maximum continuous inlet pressure		mbar	1 × 10 ³	1 × 10 ³	20	20	20	20	1
		Pa	1 × 10 ⁵	1 × 10 ⁵	2 × 10 ³	2 × 10 ³	2 × 10 ³	2 × 10 ³	1 × 10 ²
Inlet connection		-	ISO40 bolted	ISO63 bolted	ISO63 bolted	ISO100 bolted	ISO63 bolted	ISO100 bolted	ISO 160 bolted
Outlet connection		-	NW40	NW40	NW40	NW40	NW40	NW40	NW40

Table 2-1 - Technical data

iQDP pump operating temperature (measured at the thermal snap-switch position)	Maximum water consumption (l h ⁻¹) of pump operating with 50 Hz electrical supply, at ultimate vacuum with cooling-water supply temperature of 20 °C and a pressure differential across the supply and return of 30 psi (1.9 × 10 ⁵ Pa)				
	iQDP40	iQDP80	iQDP40/iQMB250 iQDP40/iQMB500	iQDP80/iQMB250 iQDP80/iQMB500	iQDP80/iQMB1200
55 °C	300	324	300	324	324
70 °C	150	165	225	240	246
90 °C	135	126	225	216	204

Table 2-2 - Cooling-water consumption

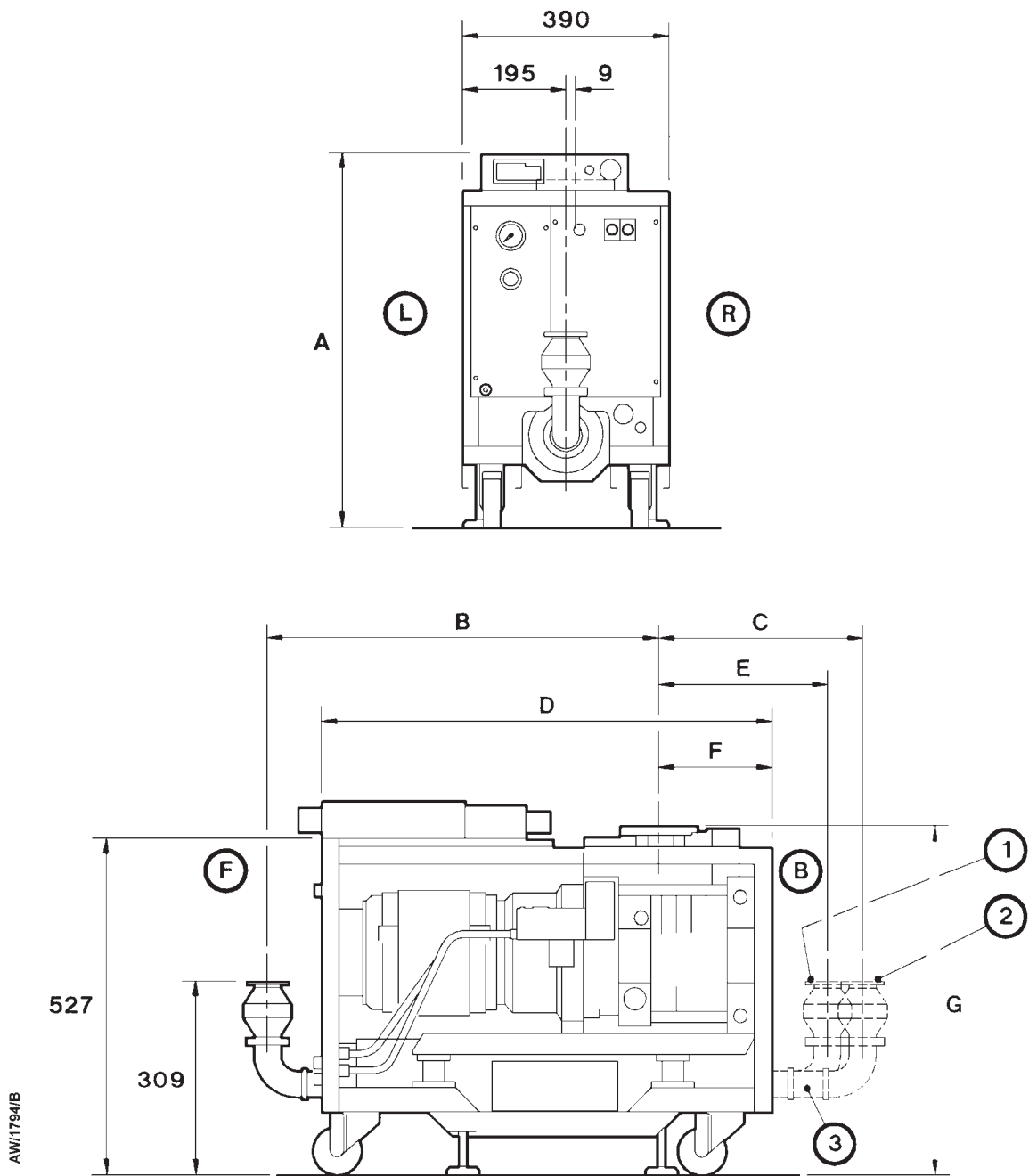

- | | |
|--|--------------------------------|
| 1. Alternative outlet position (without adaptor) | L Left-hand side of iQ system |
| 2. Alternative outlet position (with adaptor) | R Right-hand side of iQ system |
| 3. Adaptor | F Front of iQ system |
| | B Back of iQ system |

Pumping system	A	B	C	D	E	F	G
iQDP40	597	581	-	695	371	199	554
iQDP80	597	723	337	830	283	188	528

Figure 2-1 - Dimensions of iQDP40 and iQDP80 systems without acoustic enclosures (mm)

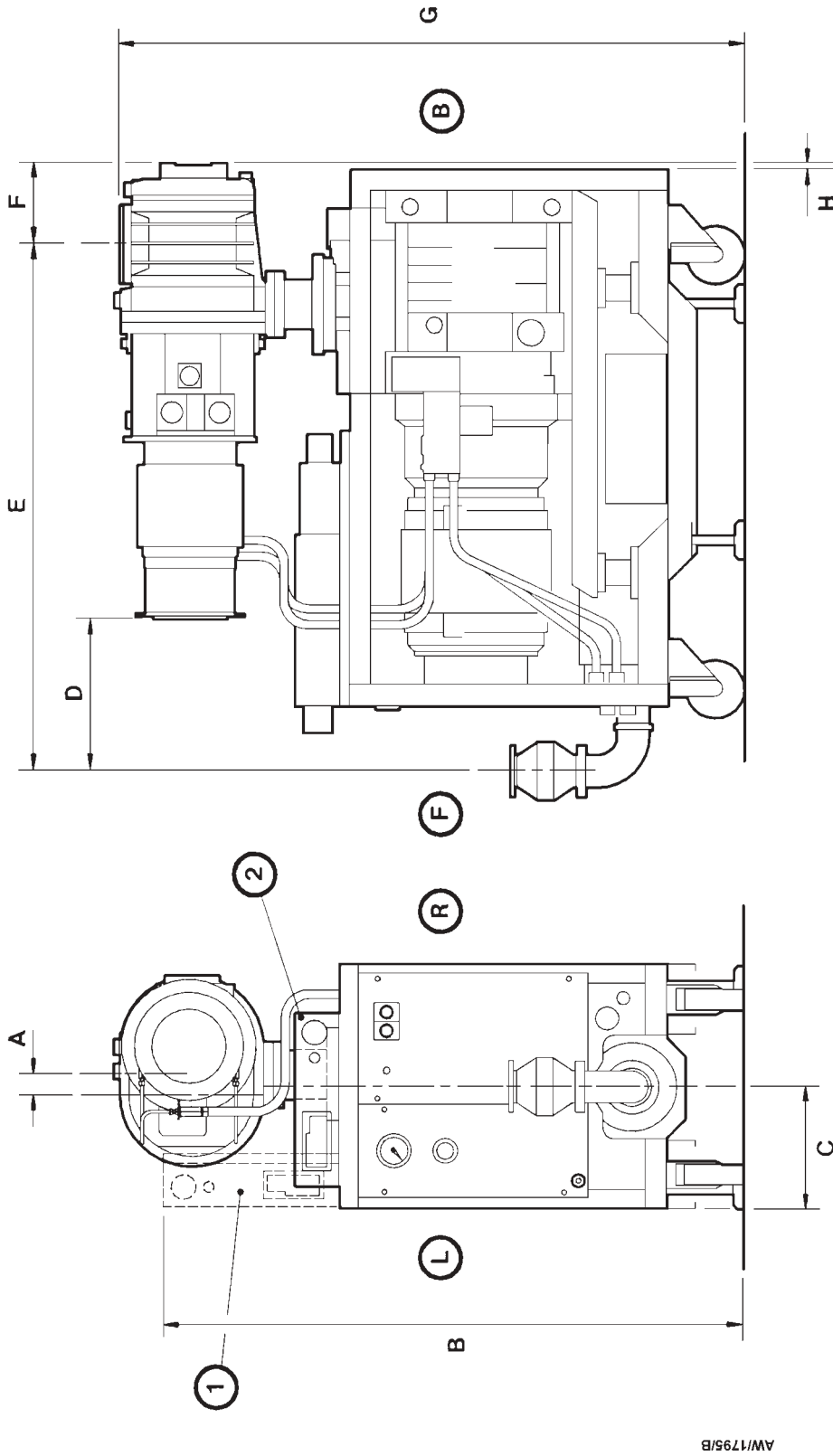

- L Left-hand side of iQ system
 R Right-hand side of iQ system
 F Front of iQ system
 B Back of iQ system
 1. Electrics Module (iQDP40/iQMB250F)
 2. Electrics Module (iQDP80/iQMB250F)

Pumping system	A	B	C	D	E	F	G	H
iQDP40/iQMB250F	8.5	798	195	116	679	137	860.5*	36
iQDP80/iQMB250F	8.5	-	195	258	821.5	137	842	46

* Electrics Module mounted horizontally (2). With the Electrics Module mounted vertically (1), this height is 784 and allows the iQ system to replace a QDP40/QMB250F installation: see Section 8.4.3.

Figure 2-2 - Dimensions of iQDP40 / 80 systems with direct mounted iQMB250F pump, without acoustic enclosures (mm)

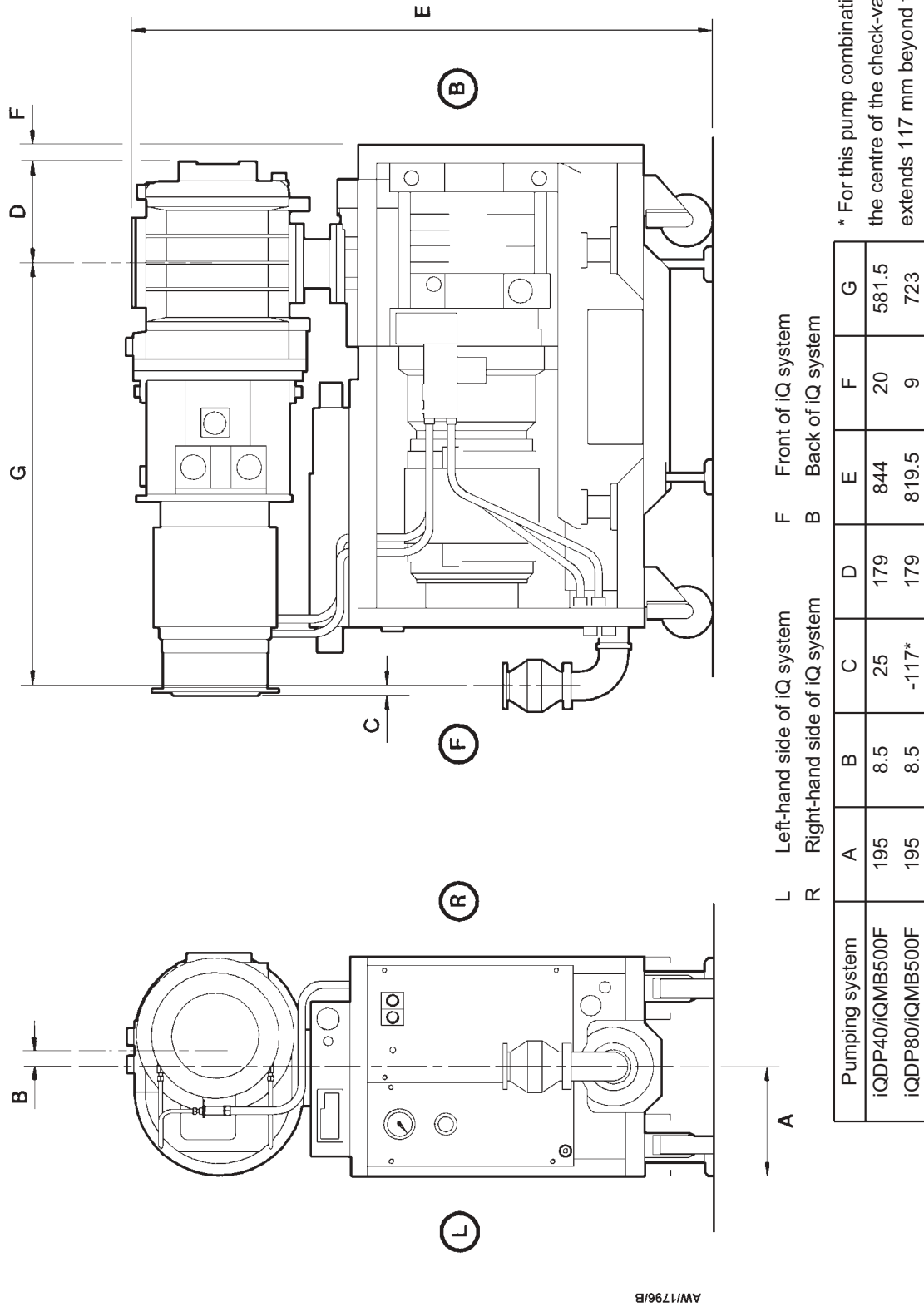
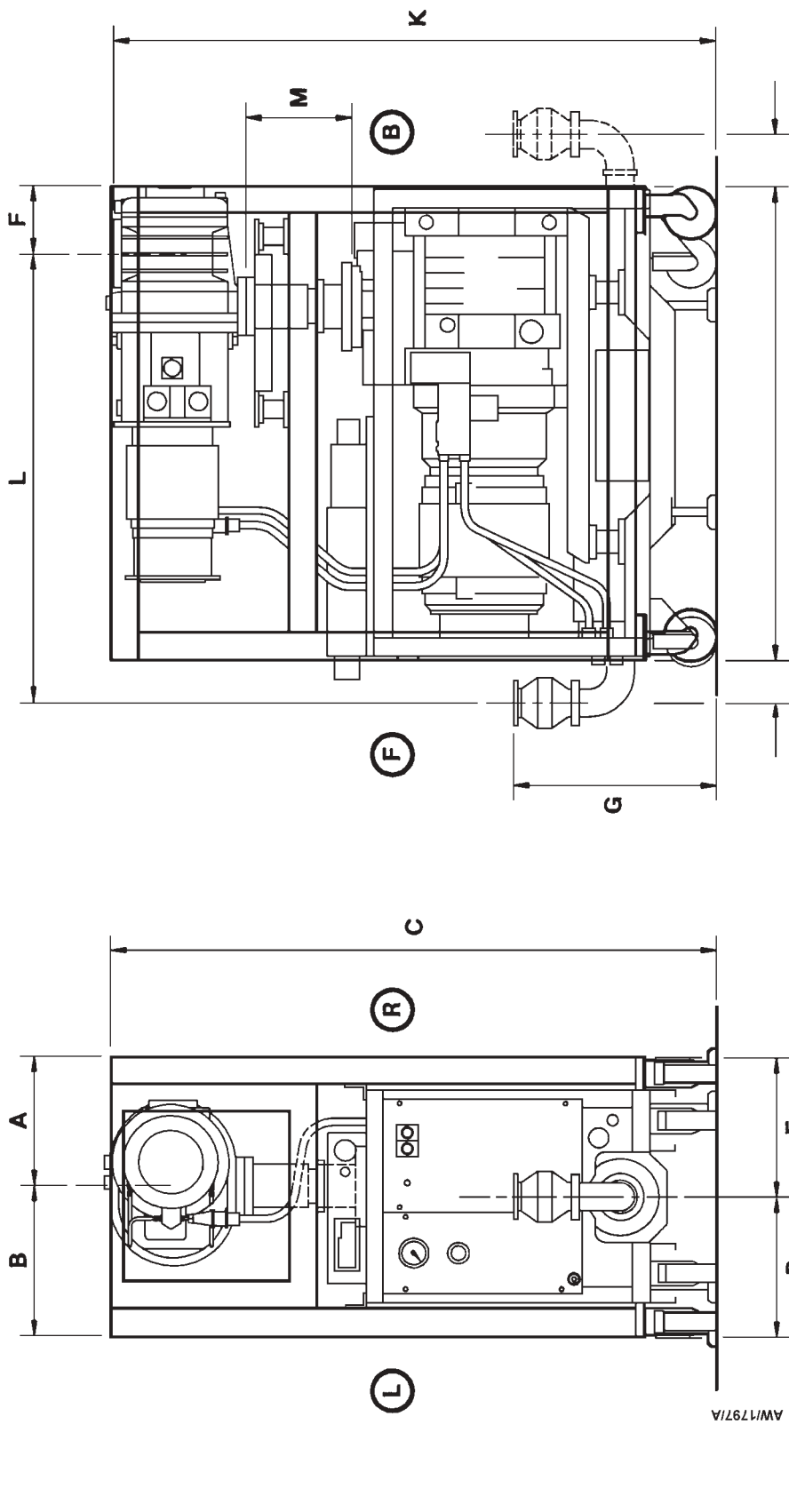

Figure 2-3 - Dimensions of iQDP40 /80 systems with direct mounted iQMB500F pump, without acoustic enclosures (mm)



Pumping system	A	B	C	D	E	F	G	H	I	J	K	L	M
iQDP40/iQMB250F	251.5	268.5	990	260	260	164.5	314	760	108.5	83.5	967	679	179
iQDP40/iQMB500F	251.5	268.5	990	260	260	262.5	314	890	108.5	-46.5*	948	581	179
iQDP80/iQMB250F	251.5	268.5	990	260	260	140.5	314	890	98.5	71.5	967	821	204
iQDP80/iQMB500F	251.5	268.5	990	260	260	238.5	314	890	98.5	71.5	948	723	204
iQDP80/iQMB1200F	251.5	268.5	1050	260	260	318.5	314	1050	-69.5*	79.5	1018	811	218

- L Left-hand side of frame
- R Right-hand side of frame
- B Back of frame
- F Front of frame

* In these pump combinations, the centre of the exhaust-silencer check-valve is (46.5 mm or 69.5 mm) inside the end of the iQMB Booster Frame

Figure 2-4 - Dimensions of booster frame mounted iQ systems, without acoustic enclosures (mm)

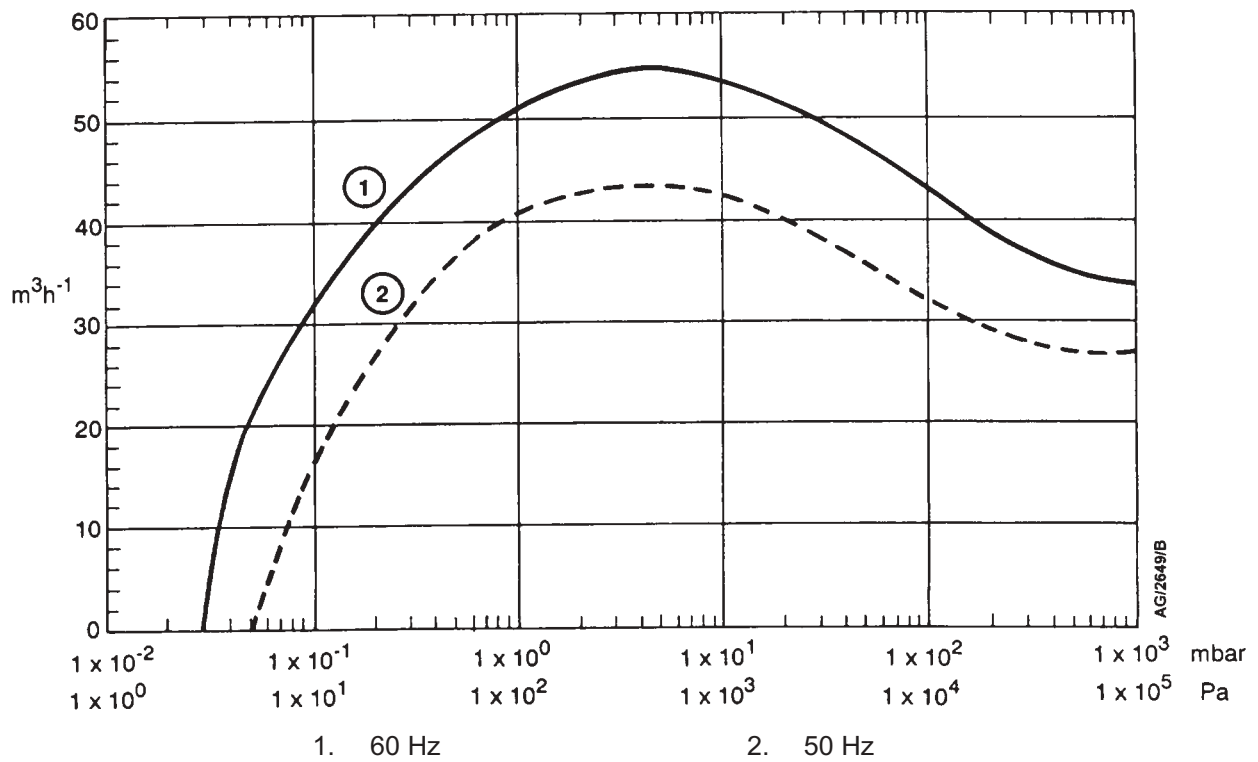

Figure 2-5 - Typical pumping speeds for iQDP40: pumping speed ($\text{m}^3 \text{h}^{-1}$) against pressure

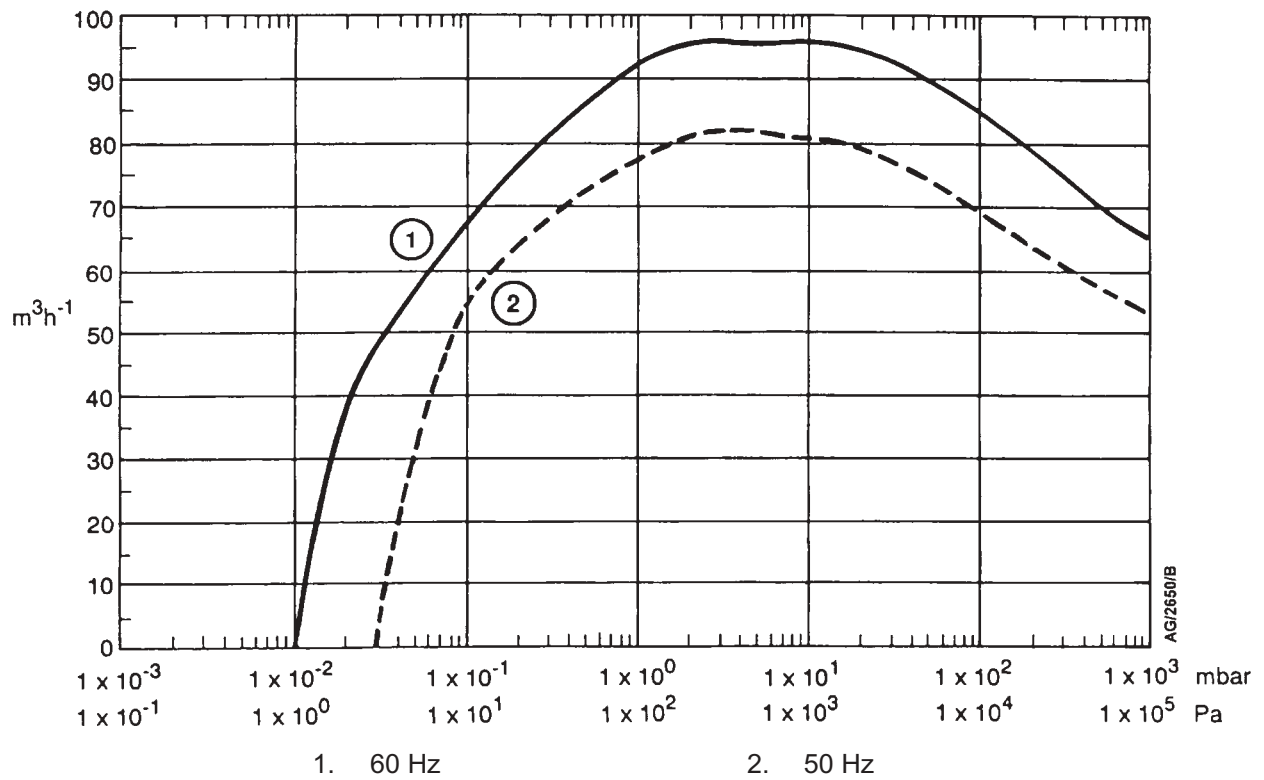

Figure 2-6 - Typical pumping speeds for iQDP80: pumping speed ($\text{m}^3 \text{h}^{-1}$) against pressure

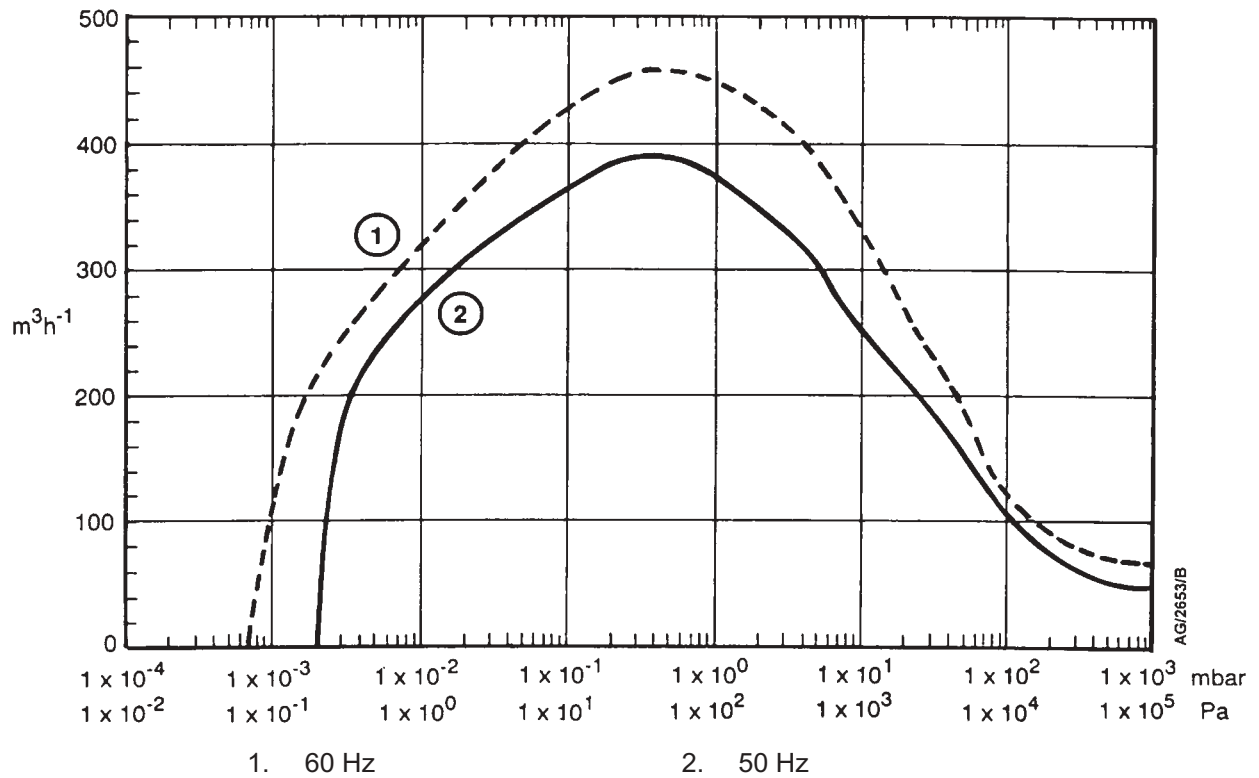

Figure 2-9 - Typical pumping speeds for iQDP80/iQMB500F: pumping speed ($m^3 h^{-1}$) against pressure

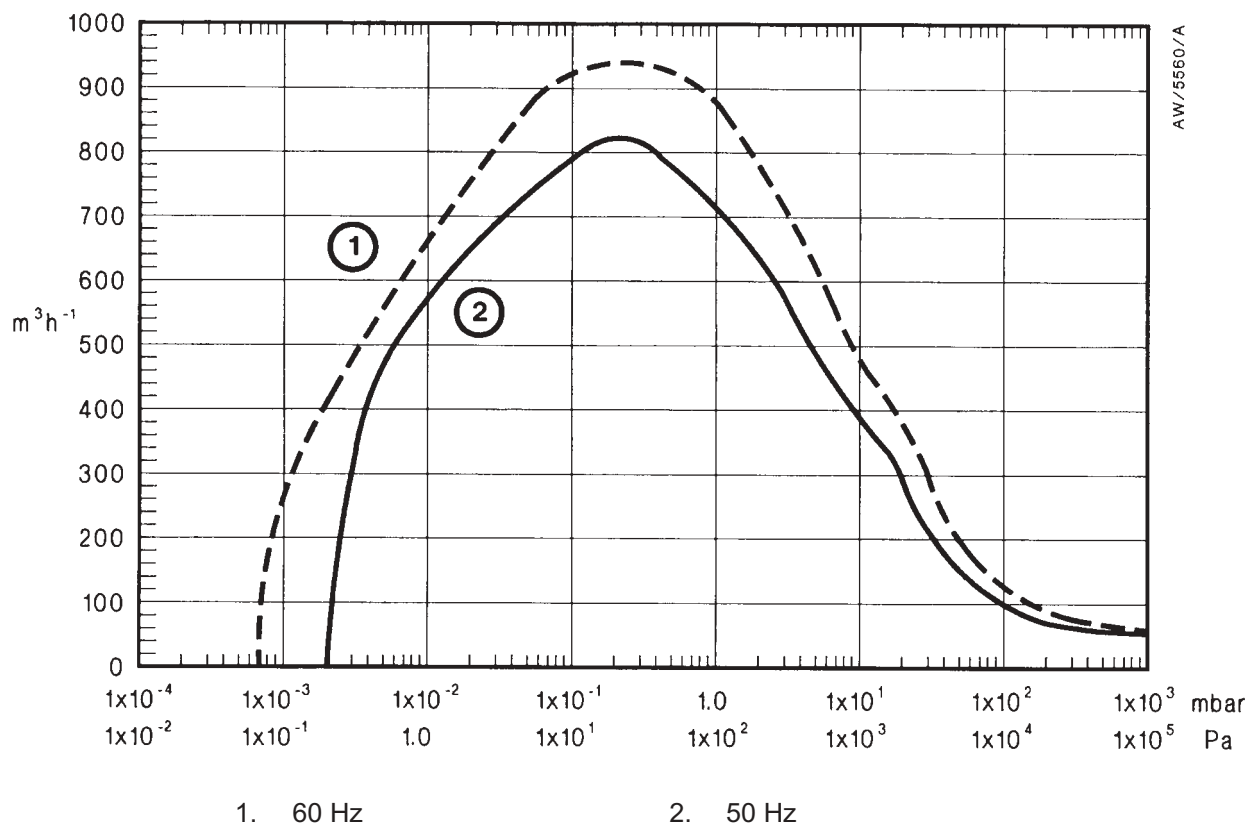
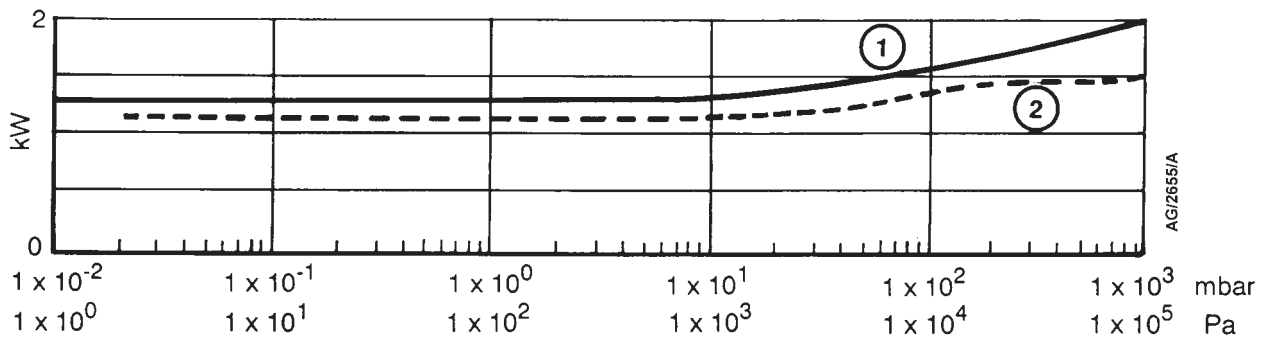

Figure 2-10 - Typical pumping speeds for iQDP80/iQMB1200F: pumping speed ($m^3 h^{-1}$) against pressure



1. 60 Hz

2. 50 Hz

Figure 2-11 - iQDP40 power curves: electrical power input (kW) against inlet pressure

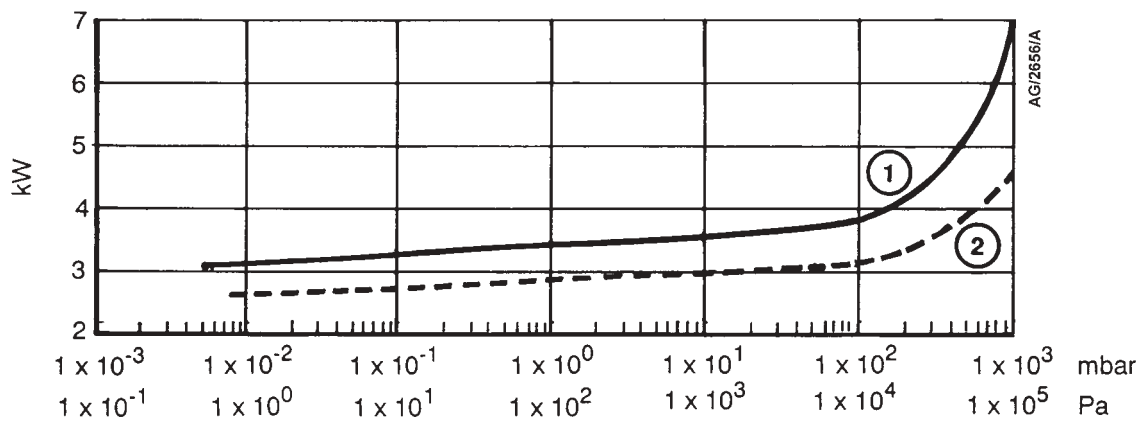

1. 60 Hz

2. 50 Hz

Figure 2-12 - iQDP80 power curves: electrical power input (kW) against inlet pressure

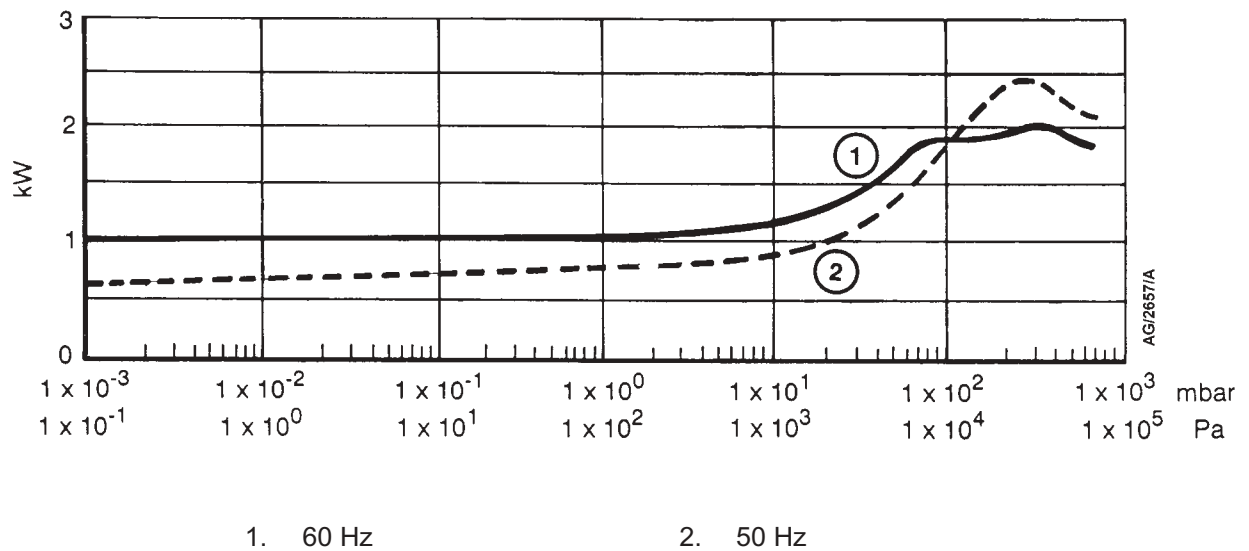

Figure 2-13 - iQMB250 power curves: electrical power input (kW) against inlet pressure

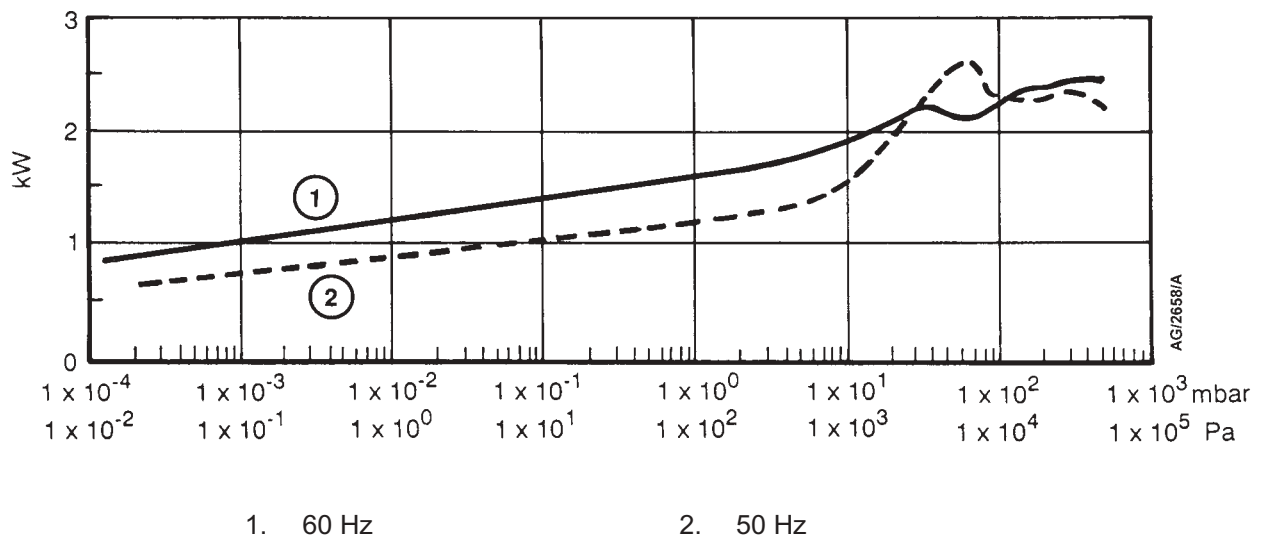

Figure 2-14 - iQMB500 power curves: electrical power input (kW) against inlet pressure

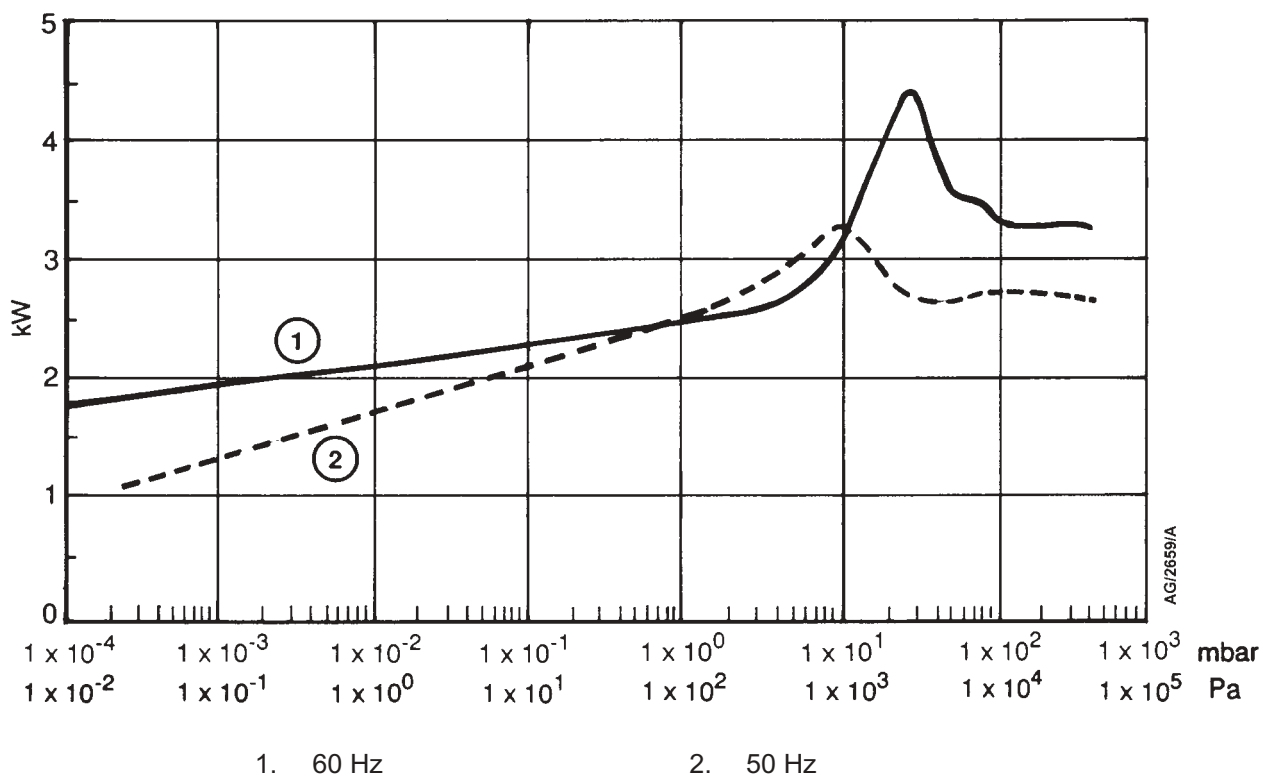

Figure 2-15 - iQMB1200 power curves: electrical power input (kW) against inlet pressure

2.4 Temperature control system

Note: A BOC Edwards Material Safety Data Sheet for the coolant used in the iQDP pump is available on request.

iQDP water-cooling system	
Type	Indirect water-to-coolant heat exchanger
Coolant capacity	1.7 litres
Thermostatic control-valve	
Manufacturer/model/part number	Danfoss/AVTA DN15/003N2110
Operating temperature range	50 to 90 °C
Maximum sensor temperature	130 °C
iQDP shut-down thermal snap-switch	
Opening temperature	150 ± 3 °C
Closing temperature	133 ± 4 °C
iQDP pump temperature and motor temperature thermocouples	K type class 1
iQDP and iQMB motor-protection thermistors	
Type	Positive temperature coefficient
Reference temperature	160 °C
Compliant with	IEC 34-11 (BS4999 part 111)

2.5 Lubrication

Note: BOC Edwards Material Safety Data Sheets for the oils and greases referenced in the following sections are available on request.

2.5.1 iQDP pump

Gearbox	
Capacity	0.4 litres
Grade of oil	SAE 40
ISO viscosity grade	150
Recommended perfluoropolyether oils	Drynert 25/6, Fomblin Y25, Krytox 1525
High vacuum bearings	
Grease type	Perfluoropolyether
Recommended grease	Fomblin RT15

2.5.2 iQMB pump

Recommended oil type	Fomblin YVAC 16/6 or Krytox 1514		
Recommended grease (for iQMB250F/ iQMB500F rear bearing end-cover)	Fomblin RT15		
Oil capacity (l)	iQMB250F	iQMB500F	iQMB1200F
Coupling-cover	1.5	1.5	2.4
Shaft-seal reservoir	0.125	0.125	0.125
Gear-case	-	-	1.25

2.6 Exhaust-silencer

Mass	5.5 kg
Gas temperature	5 to 150 °C
Exhaust pulsation attenuation	30 dB(A)

2.7 Exhaust check-valve

Mass	0.95 kg
Gas temperature	5 to 130 °C
Reverse flow leak tightness when clean (minimum)	0.4 mbar l s ⁻¹ (4 x 10 ¹ Pa l s ⁻¹)

2.8 Electrical data

Note: To determine the full load current rating for your iQ system, add the appropriate figures (given in Table 2-3) for the iQDP pump and the iQMB pump (if any) in your system.

Electrical supply	
Supply voltage	200-208/380-415 V at 50 Hz, 3-phase 200-230/460 V at 60 Hz, 3-phase
Voltage tolerance	±10% (except for 208 V and 415 V at 50 Hz which are +6% and -10%)
Full load current ratings	See Table 2-3
Electrics Module fuse ratings	
F1, F2, F3 (iQMB electrical supply fuses)	20 A, 600 V, Class J *
F4, F5, F6 (iQDP electrical supply fuses)	30 A, 600 V, Class J *
F7 (Gas Module fuse)	3.15 A, T-type
F8 (iQ Interface Module fuse)	1.6 A, T-type
F9 (Emergency stop circuit fuse)	3.15 A, T-type
FS6, FS8 (Self resetting fuses)	900 mA *
FS7, FS9	2 A, 500 V, ceramic *
Emergency stop switch rating	24 V a.c./d.c., 5 A max

* Provided for information only: you cannot replace these fuses.

External emergency stop switch

Rating 24 V a.c., 5 A
 Load 700 mA (inductive)

Supply voltage and frequency →		200-208 V 50 Hz	200-208 V 60 Hz	230 V 60 Hz	380-415 V 50 Hz	460 V 60 Hz
iQDP40	Full load (A)	8.7	8.8	7.8	5.0	4.4
	Rating (kW)	2.2	2.2	2.2	2.2	2.2
iQDP80 (4 kW)	Full load (A)	16.0	16.0	14.2	8.0	8.0
	Rating (kW)	4.0	4.0	4.0	4.0	4.0
iQDP80 (6 kW)	Full load (A)	18.9	22.2	19.7	9.5	9.9
	Rating (kW)	5.0	6.0	6.0	5.0	6.0
iQMB250	Full load (A)	8.7	8.8	7.8	5.0	4.4
	Rating (kW)	2.2	2.2	2.2	2.2	2.2
iQMB500	Full load (A)	8.7	8.8	7.8	5.0	4.4
	Rating (kW)	2.2	2.2	2.2	2.2	2.2
iQMB1200	Full load (A)	16	16	14.2	8	8
	Rating (kW)	4	4	4	4	4

Table 2-3 - Full load current ratings

2.9 Gas system

Note: Once you have connected your nitrogen supply and adjusted the nitrogen supply pressure, for optimum performance of the pressure regulator in the Gas Module, we recommend that the stability of your nitrogen supply is such that the supply pressure remains within ± 20 psi of the adjusted pressure.

Nitrogen supply pressure range	20 to 100 psig (2.4 to 7.9 bar absolute, 2.4×10^5 to 7.9×10^5 Pa)
Flow rates	See Tables 2-4 and 2-5
Pressure gauge operating range*	0 to 30 psig (1 to 3 bar absolute, 1×10^5 to 3×10^5 Pa)
Pressure transducer accuracy † #	± 0.6 psi ($\pm 4.1 \times 10^{-2}$ bar, $\pm 4.1 \times 10^3$ Pa) at 6 psig (1.4 bar absolute, 1.4×10^5 Pa)
Pressure-switch operating pressure #	9 ± 0.6 psig ($1.48 \pm 4 \times 10^{-2}$ bar absolute, $1.48 \times 10^5 \pm 4 \times 10^3$ Pa) rising
Flow transducer accuracy † #	± 3.0 slm ($\pm 5 \times 10^3$ Pa l s ⁻¹)

* Shaft-Seals Purge Module

† Gas-Ballast Module

Gas System Module Series 2

Purge flows	Typical purge flows		Maximum purge flows	
	slm	Pa l s ⁻¹	slm	Pa l s ⁻¹
Shaft-seals purge	7	1.2 x 10 ⁴	17	1.2 x 10 ⁴
3/4-interstage purge	-	-	-	-
2/3-interstage purge	-	-	-	-
Exhaust-purge	-	-	-	-
Inlet-purge	-	-	-	-
Total flow	7	1.2 x 10 ⁴	17	2.9 x 10 ⁴

Table 2-4 - Nitrogen purge flow rates: Shaft-Seals Purge Module

Typical purge flows					
Purge flows	Flow sensor	Gas Ballast Module		Gas System Module	
		slm	Pa l s ⁻¹	slm	Pa l s ⁻¹
Shaft-seals purge ♦	Final stage	7	1.2 x 10 ⁴	7	1.2 x 10 ⁴
3/4-interstage purge ♦	Final stage	25	4.2 x 10 ⁴	25	4.2 x 10 ⁴
2/3-interstage purge	Auxiliary	-	-	10	1.7 x 10 ⁴
Exhaust-purge	Auxiliary	-	-	5	8.5 x 10 ³
Inlet-purge ▼	Auxiliary	-	-	25 ▼	(4.2 x 10 ⁴) *
Typical final stage purge flow		32 (7)*	5.4 x 10 ⁴ (1.2 x 10 ⁴)*	32 (7)*	5.4 x 10 ⁴ (1.2 x 10 ⁴)*
Typical auxiliary purge flow		-	-	15 (5)*	2.5 x 10 ⁴ (8.5 x 10 ³)*
Typical total purge flow		32 (7)*	5.4 x 10 ⁴ (1.2 x 10 ⁴)*	47 (12)*	8 x 10 ⁴ (2 x 10 ⁴)*

Maximum purge flows					
Shaft-seals purge	Final stage	17	2.9 x 10 ⁴	17	2.9 x 10 ⁴
3/4-interstage purge	Final stage	35 [†] , 40 [▲]	5.6 x 10 ^{4†} , 6.8 x 10 ^{4▲}	35 [†] , 40 [▲]	5.6 x 10 ^{4†} , 6.8 x 10 ^{4▲}
2/3-interstage purge	Auxiliary	-	-	20 [†] , 25 [▲]	3.4 x 10 ^{4†} , 4.2 x 10 ^{4▲}
Exhaust-purge	Auxiliary	-	-	5	8.5 x 10 ³
Inlet-purge	Auxiliary	-	-	25	4.2 x 10 ⁴
Maximum final stage purge flow		52 [†] , 57 [▲]	8.8 x 10 ^{4†} , 9.7 x 10 ^{4▲}	52 [†] , 57 [▲]	8.8 x 10 ^{4†} , 9.7 x 10 ^{4▲}
Maximum auxiliary purge flow		-	-	50 [†] , 55 [▲]	8.5 x 10 ^{4†} , 9.3 x 10 ^{4▲}
Maximum total purge flow		52 [†] , 57 [▲]	8.8 x 10 ^{4†} , 9.7 x 10 ^{4▲}	102 [†] , 112 [▲]	1.7 x 10 ^{5†} , 1.9 x 10 ^{5▲}

♦ Typical flow rate. Minimum flow rate = 1 slm (1.7 x 10³ Pa l s⁻¹); maximum flow rate = 17 slm (2.9 x 10⁴ Pa l s⁻¹).
Adjust interstage purge flow rate to give a final stage purge flow rate of 32 slm (5.4 x 10⁴ Pa l s⁻¹).

▼ Inlet purge is switched off under normal operating conditions, with gas ballast on.

* Purge flow rates in brackets are with Gas Ballast off.

† iQDP40, ▲ iQDP80

Table 2-5 - Nitrogen purge flow rates: Gas Ballast Module and Gas System Module Series 2

2.10 Materials in contact with process gases

Pump shafts and rotors	Cast iron
Internal and external shaft-seals	
iQDP pump	PTFE (polytetrafluoroethylene)
iQMB pump	PTFE and fluoroelastomer
iQDP pump nitrogen pipelines	Stainless steel
Gas Module nitrogen components	Brass, Stainless steel, Decabon flexible pipes

2.11 Default setpoints

The default setpoints are shown in Tables 2-6 to 2-9. Where there is an 'ADJ' (adjust) entry in these tables, this specifies that the setpoints are usually not used and the default setpoint is preset so that no warning or alarm condition could result from sensor readings. If required you can adjust these 'ADJ' setpoints for your application, so that suitable warnings and alarms can be generated: refer to Section 5.

Parameter	Unit	Default setpoint values			
		Low alarm	Low warning	High warning	High alarm
iQDP40 power consumption: 2.2 kW	kW	ADJ	0.0	2.4	2.9
iQDP80 power consumption: 4.0 kW	kW	ADJ	0.0	4.0	4.7
iQDP80 power consumption: 6.0 kW (see Section 5.3.1)	kW	ADJ	0.0	6.0 #	7.2 #
iQMB250F power consumption ▲	kW	ADJ	0.0	2.4	2.9
iQMB500F power consumption ▲	kW	ADJ	0.0	2.4	2.9
iQMB1200F power consumption ▲	kW	ADJ	0.0	4.0	4.7

You must set these setpoints when you configure the iQ system: refer to Section 5.3.1.

▲ During start up and pumpdown, the actual motor power consumption will rise above the high alarm setpoint for a short time. On detecting high power consumption, the Electrics Module does not immediately raise an alarm, but waits for a short time, to take account of this.

Table 2-6 - Electrics Module default setpoints

Parameter	Unit †	Default setpoint values			
		Low alarm	Low warning	High warning	High alarm
Final stage nitrogen flow rate: 3/4-interstage purge off	slm	ADJ	1.0	25.5	ADJ
Final stage nitrogen flow rate: 3/4-interstage purge on	slm	ADJ	22.0	53.0	ADJ
Shaft-seals purge pressure	psig	5.0	*	*	8.0

† Only slm values are given in the table, because only slm values can be entered in the Pump Display Module. To convert slm values to Pa l s⁻¹, multiply by (1.013 / 60) × 10⁵.

* These setpoints depend on whether gas ballast is on or off.

Table 2-7 - Gas-Ballast Module default setpoints

Parameter		Unit †	Default setpoint values			
			Low alarm	Low warning	High warning	High alarm
2/3-interstage purge off, 3/4-interstage purge off, inlet-purge off	Final stage nitrogen flow rate	slm	ADJ	ADJ	25.5	ADJ
	Auxiliary nitrogen flow rate	slm	ADJ	2.5	7.5	ADJ
2/3-interstage purge on, 3/4-interstage purge on, inlet-purge off	Final stage nitrogen flow rate	slm	ADJ	22.0	53.0	ADJ
	Auxiliary nitrogen flow rate	slm	ADJ	11.5	18.5	ADJ
2/3-interstage purge on, 3/4-interstage purge on, inlet-purge on	Final stage nitrogen flow rate	slm	ADJ	22.0	53.0	ADJ
	Auxiliary nitrogen flow rate	slm	ADJ	33.0	47.0	ADJ
Exhaust pressure		psig	ADJ	ADJ	5.0	8.0
Shaft-seals purge pressure		psig	5.0	*	*	8.0

† Only slm gas flow values are given in the table, because only slm values can be entered in the Pump Display Module. To convert slm values to Pa l s⁻¹, multiply by (1.013 / 60) × 10⁵.

* These setpoints depend on whether gas ballast and inlet purge are on or off.

Table 2-8 - Gas System Module Series 2 default setpoints

Parameter	Unit	Default setpoint values			
		Low alarm	Low warning	High warning	High alarm
iQDP pump temperature	°C	ADJ	60	88	95
iQDP motor temperature	°C	ADJ	ADJ	70	ADJ
iQMB motor temperature	°C	ADJ	ADJ	70	ADJ
Exhaust gas temperature	°C	ADJ	ADJ	200	ADJ

Table 2-9 - Sensor Monitoring Module default setpoints

2.12 Connections

Inlet and outlet	See Table 2-1
Electrical supply connector	
Type	Harting HAN-K-4/2
Cable outside diameter range	18 to 27 mm
Maximum conductor cross-sectional area	16 mm ²
Pump Display Module connector	XLR type 4-way
Network communications connector	XLR type 4-way
GRC bypass connector	6-pin DIN
Emergency stop connector	XLR type 6-way
Nitrogen supply connector	¹ / ₄ inch compression fitting

3 INSTALLATION

3.1 Safety

WARNING

Obey the safety instructions given below and take note of appropriate precautions. If you do not, you can cause injury to people and damage to equipment

- A suitably trained and supervised technician must install the iQ system.
- Ensure that the installation technician is familiar with the safety procedures which relate to the products pumped. Wear the appropriate safety-clothing when you come into contact with contaminated components. Dismantle and clean contaminated components inside a fume-cupboard.
- Vent and purge the process system (if the iQ system is to replace an existing pumping system) with nitrogen for 15 minutes before you start installation work.
- Disconnect the other components in the process system from the electrical supply so that they cannot be operated accidentally.
- Do not reuse 'O' rings or 'O' ring assemblies, and do not allow debris to get into the iQ system during installation.
- Wipe up any water, Drystar coolant or oil spilt during installation, so that people cannot slip over any spillages.
- Safely route and secure all cables, hoses and pipes during installation, so that people cannot trip over them.
- Do not remove the temporary cover or the blanking-plate from the iQ system inlet until you are ready to connect the iQ system to your vacuum system. Do not operate the iQ system unless the inlet blanking-plate is fitted, or the iQ system is connected to your vacuum system.
- Do not remove the temporary cover or the blanking-plate from the iQ exhaust check-valve outlet until you are ready to connect the iQ system to your exhaust-extraction system. Do not operate the iQ system unless the iQ system is connected to your exhaust-extraction system.
- Obey all local and national rules and safety regulations when you install the iQ system.
- Consult BOC Edwards publication P300-20-000 (Vacuum Pump and Vacuum System Safety) before you pump hazardous materials. This publication is available on request: contact your supplier or BOC Edwards.

3.2 Installation checklist

The operations required to install the iQ system and the sections of this instruction manual which describe those operations are shown in Table 3-1.

Installation operation	Section
Unpack and inspect	3.3
Locate the iQ system	3.4
Install the iQMB mechanical booster pump (if necessary)	3.5
Configure the Sensor Monitoring Module for your iQ system	3.6
Fit Oil-Level Monitors (optional)	3.7
Fill the iQMB pump with oil (if fitted)	3.8
Install or replace optional accessories (if necessary)	3.9
Check the iQDP pump oil level	3.10
Check the iQDP pump coolant level	3.11
Connect to your process system	3.12
Connect to your exhaust extraction system	3.13
Install the iQ Exhaust Temperature Sensor (optional)	3.13.1
Configure the iQ system to use the alternative outlet position (optional)	3.13.2
Connect the iQ outlet to your exhaust-extraction system	3.13.3
Connect the nitrogen supply	3.14
Leak test the system	3.15
Install additional safety equipment (optional)	3.16
Connect to your emergency stop circuit (optional)	3.17
Connect the GRC bypass output to your GRC (optional)	3.18
Electrical supply and RF earth (ground) connections	3.19
Configure the Electrics Module for your electrical supply	3.19.1
Configure the pump(s) for your electrical supply	3.19.2
Connect the electrical supply	3.19.3
Connect an additional RF earth (ground): optional	3.19.4
Connect the cooling-water pipelines	3.20
Adjust the interstage purge flow rates if necessary	3.21
Commission the iQ system	3.22
Switch on the iQ system pumps	3.22.1
Check the nitrogen pressure and adjust if necessary	3.22.2/3.22.3
Adjust the iQDP pump operating temperature (optional)	3.22.4
Fit the Acoustic Enclosure (optional)	3.23

Table 3-1 - Installation checklist

3.3 Unpack and inspect

WARNING

You must use suitable lifting equipment to move the iQ system. It is too heavy to lift by hand.

WARNING

Do not fit the lifting bolts on the iQMB pump to lift or move an iQDP/iQMB combination iQ system. If you do, the bolts may break and you can damage the iQ system and cause injury to people.

WARNING

Ensure that the maximum angle between paired slings used to lift the iQ system is 60°.

The iQ system is supplied sealed in an air-tight bag. To prevent contamination of the iQ system, before you unpack and inspect the iQ system we recommend that you move the pallet as close as possible to the clean area in which you will install the system. Remove the air-tight bag carefully; use the bag as a dust cover while you wheel the iQ system to its final operating position. Use the following procedure to unpack and inspect the iQ system.

1. Place the pallet in a convenient position with a fork-lift truck or a pallet truck.
2. Remove the staples which secure the cardboard box to the pallet, then remove the cardboard box; alternatively, open the top of the cardboard box. Tear open the foil bag which encloses the iQ system.
3. Refer to Figure 3-1. Remove the two nuts and washers (2) which secure the front of the pump to the pallet. Remove the two nuts and washers (2, not shown) which secure the rear of the pump to the pallet. Dispose of the nuts and washers.
4. If you have a direct mounted combination iQ system with an iQDP40 pump, fit the two lifting bolts (supplied with the iQ system) to two diagonal corners of the iQDP pump frame (Figure 1-1, item 5).

Otherwise, fit the four lifting bolts to the top of the booster frame (on booster frame mounted combination iQ systems) or to the top of the iQDP pump frame (on direct mounted combination systems with an iQDP80 pump).

5. Use suitable lifting-equipment attached to the lifting bolts to remove the iQ system from its pallet. Do not try to lift the pump by hand (see Section 2 for the mass of the iQ system).
6. Inspect the iQ system. If the iQ system or any other item is damaged, notify your supplier and the carrier in writing within three days; state the Item Number of the iQ system together with your order number and your supplier's invoice number. Retain all packing materials for inspection. Do not use the iQ system if it is damaged.

(Continued on page 3-4)

7. Check that the pallet contains the items listed in Table 3-2. If any of these items is missing, notify your supplier in writing within three days.
8. If the iQ system is not to be used immediately, replace the packing materials. Store the iQ system in suitable conditions as described in Section 7.

Qty	Description	Check (✓)
1	iQ dry pumping system	<input type="checkbox"/>
	Fitting-kit which contains the following:	
1	Inlet seal ('O' ring or trapped 'O' ring)	<input type="checkbox"/>
1	Cooling-water quick-release connectors (pair)	<input type="checkbox"/>
1	NW40 trapped 'O' ring	<input type="checkbox"/>
1	NW40 clamp	<input type="checkbox"/>
1	Module connector terminator plug	<input type="checkbox"/>
1	Electrical supply connector kit	<input type="checkbox"/>
1	Lifting bolts	<input type="checkbox"/>

* If you have a booster frame mounted iQ system, you will receive four lifting bolts, otherwise you will receive two lifting bolts.

Table 3-2 - Checklist of components

3.4 Locate the iQ system

WARNING

You must use suitable lifting equipment to move the iQ system. It is too heavy to lift by hand.

WARNING

Do not fit the lifting bolts on the iQMB pump to lift or move an iQDP/iQMB combination pumping system. If you do, the bolts may break and you can damage the iQ system and cause injury to people.

Note: Refer to Figure 3-1. After you have located the iQ system, if you want to secure the iQ in place to prevent unwanted movement (or example, during an earthquake), fit suitable bolts or studs through the transit brackets (3) and into the floor; alternatively, fit additional suitable restraints (which you must supply) to the four levelling feet (7) or their M12 supports.

Use the following procedure to locate the iQ system in its operating position. The iQ system must be located on a firm, level surface.

1. Use suitable lifting equipment attached to the lifting bolts to move the iQ system close to its final operating position: refer to the guidelines given in Section 3.3.
2. Refer to Figure 3-1. Remove the nuts and washers (8) fitted to the top of the four levelling feet (7), then retract the levelling feet.

3. Wheel the iQ system on its castors to move it into its operating position.
4. Adjust the levelling feet: ensure that the iQ system is level and is not supported by the castors.

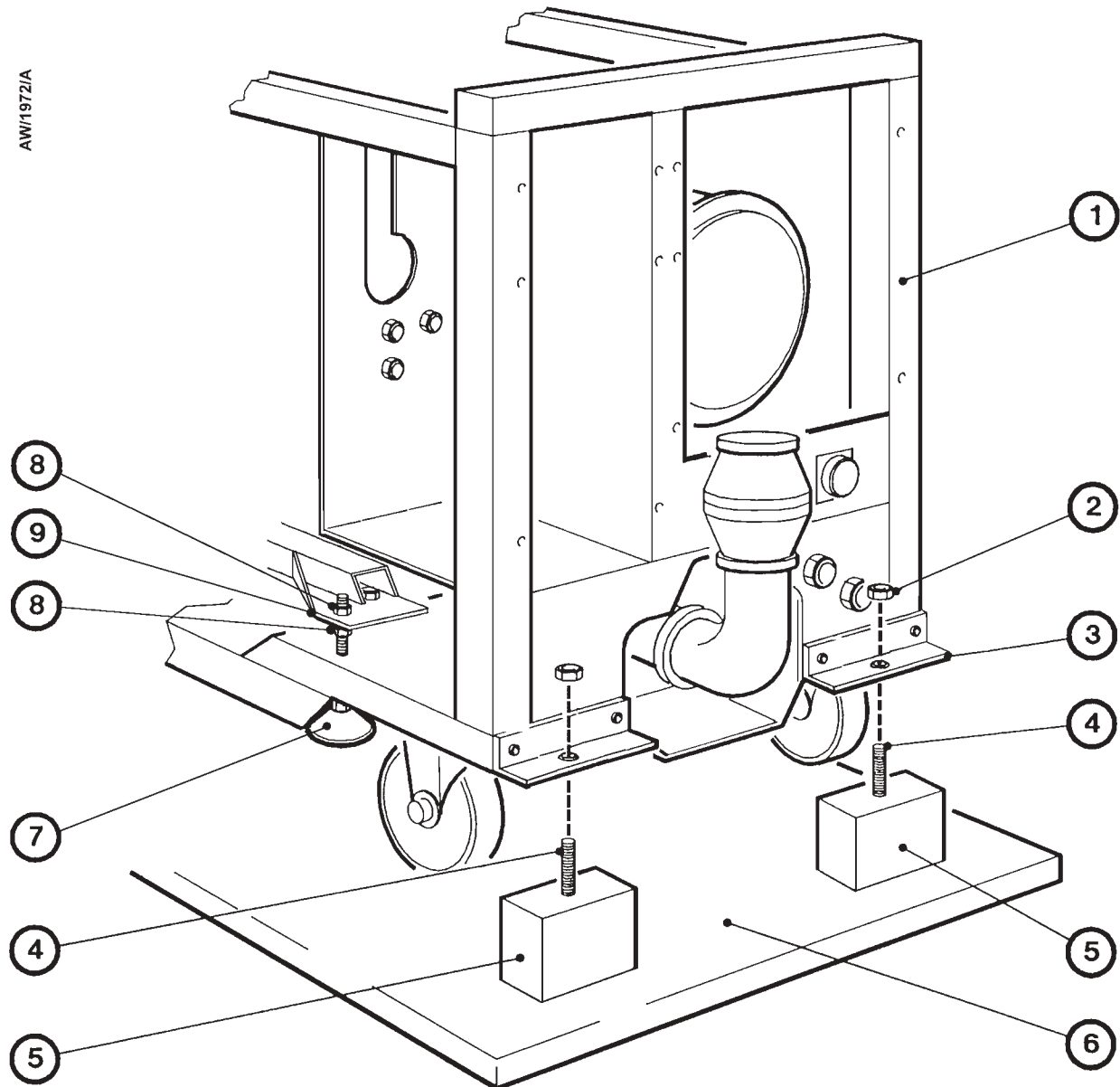

- | | |
|--------------------|-------------------|
| 1. iQDP pump frame | 6. Pallet |
| 2. Nut and washer | 7. Levelling foot |
| 3. Bracket | 8. Nut and washer |
| 4. Stud | 9. Bracket |
| 5. Block | |

Figure 3-1 - Remove the iQ system from the pallet

3.5 Install the iQMB mechanical booster pump (if necessary)

You can fit an iQMB mechanical booster pump to an iQ system in one of two ways:

- You can mount an iQMB250F or iQMB500F pump directly on the inlet of the iQDP pump. To do this, you will need a iQMB Booster Connection Kit accessory.
- You can mount an iQMB250F, iQMB500F or iQMB1200F pump on the iQDP pump in an iQMB booster frame. To do this, you will need an iQMB Booster Frame and an iQMB Booster Frame Connection Kit.

Fit the iQMB pump to the iQDP pump (and iQMB Booster Frame) as described in the instruction manuals supplied with the accessories. Refer to Section 8.4 for the Item Numbers of the accessories.

3.6 Configure the Sensor Monitoring Module for your iQ system

Note: You must set the DIP switch positions as shown below. If you do not, the iQ pumping system will not operate correctly.

Use the following procedure to configure the Sensor Monitoring Module for your iQ system. Refer to Figure 1-8.

1. Loosen the four thumbwheels (3), then remove the cover (2) from the Sensor Monitoring Module (4).
2. Ensure that the positions of DIP switches 3 and 4 (28, 29) are correct for the iQDP pump in your iQ system: refer to Table 3-3.
3. Ensure that the positions of DIP switches 1 and 2 (26, 27) are correct for the iQMB pump (if any) in your iQ system: refer to Table 3-4.
4. Refit the cover (2) over the Sensor Monitoring Module (4): ease the slots in the cover over the studs, ensure that the cover is behind the thumbwheels (3) and the plastic washers on the studs, then tighten the thumbwheels to secure the cover in place.

iQDP pump	DIP switch 3	DIP switch 4
iQDP40	Off	On
iQDP80	On	Off

Table 3-3 - DIP switches 3 and 4 positions

iQMB pump	DIP switch 1	DIP switch 2
iQMB250/500	Off	On
iQMB1200	On	Off
None	On	On
None	Off	Off

Table 3-4 - DIP switches 1 and 2 positions

3.7 Fit Oil-Level Monitors (optional)

If you will fit Oil-Level Monitors to the iQDP and/or iQMB pumps, fit them now before you fill the iQMB pump with oil or check the iQDP oil-level.

Fit the Oil-Level Monitor(s) as described in the Oil-Level Monitor instruction manual. Note that you will need to drain the oil from the iQDP pump (as described in Section 6.11) before you fit the Oil-Level Monitor to the iQDP pump.

3.8 Fill the iQMB pump with oil (if fitted)

CAUTION

Ensure that the oil-levels in the pump are correct. If an oil-level is incorrect, pump performance may be affected and the pump may be damaged.

3.8.1 Coupling-cover

We recommend that the coupling-cover oil-level is maintained at the recommended oil-level shown in Figure 3-3, item 5; if the oil-level is above or below the recommended oil-level, the performance of the pump may be affected. Do not allow the coupling-cover oil-level to fall below the bottom of the reflector plate (Figure 3-3, item 4) or the pump may be damaged.

Fill the coupling-cover with oil as described below. Refer to Figure 3-2 for the location of the filler-plug and sight-glass.

1. Remove the coupling-cover oil filler-plug (Figure 3-2, item 17).
2. Refer to Figure 3-3. Fill the coupling-cover with PFPE oil until the oil-level reaches the recommended oil-level (5) at the top of the reflector plate in the oil sight-glass (3).
3. Refit the coupling-cover oil filler-plug.

3.8.2 Shaft-seal reservoir

WARNING

Ensure the correct vented filler-plug is replaced in the shaft-seal reservoir. If you use a non-vented plug, the reservoir will be pressurised and the oil sight-glass may fracture.

We recommend that you fill the shaft-seal reservoir so that the oil-level is at the recommended oil-level, shown in Figure 3-3, item 2. You can operate the pump as long as the oil-level is above the bottom of the reflector plate.

Do not allow the shaft-seal oil-level to fall below the bottom of the reflector plate or the pump may be damaged.

Use the following procedure to fill the shaft-seal reservoir with oil.

(Continued on page 3-9)

1. Cooling-water bracket (iQMB250/500F)
2. Cooling-water bracket (iQMB1200F)
3. External evacuation port (plugged)
4. Rear bearing end-cover (iQMB1200F)
5. Oil filler-plug (iQMB1200F)
6. Oil drain-plug (under the end-cover, iQMB1200F)
7. Oil-level sight-glass (iQMB1200F)
8. Rear bearing end-cover (iQMB250/500F)
9. Oil drain-plug (under the pump)

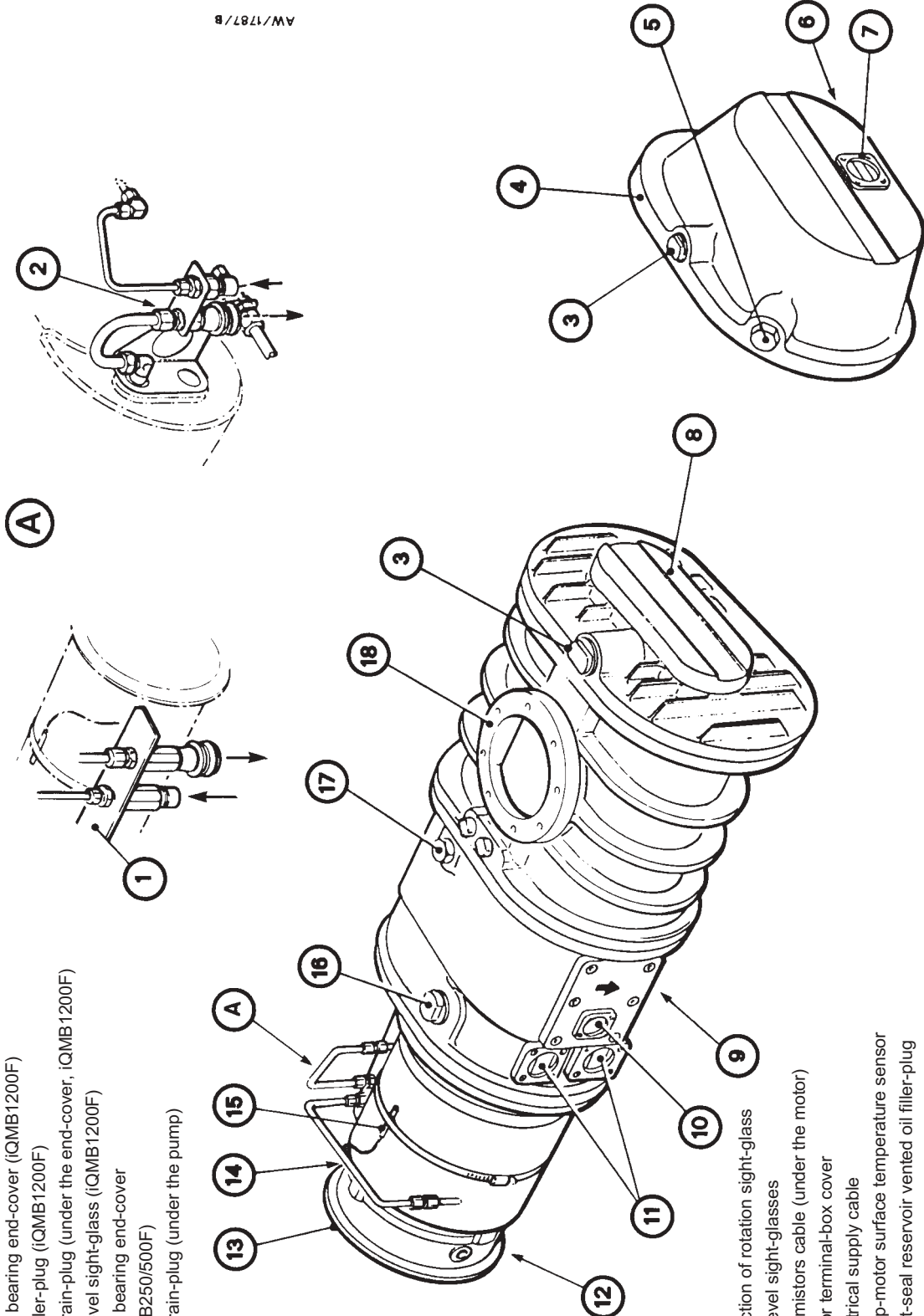

AW/1787/B

10. Direction of rotation sight-glass
11. Oil-level sight-glasses
12. Thermistors cable (under the motor)
13. Motor terminal-box cover
14. Electrical supply cable
15. Pump-motor surface temperature sensor
16. Shaft-seal reservoir vented oil filler-plug
17. Coupling-cover oil filler-plug
18. Inlet-flange

Figure 3-2 - Components of the iQMB pump

Refer to Figure 3-2 for the location of the filler-plug and sight-glass. You must use the same oil you used to fill the coupling-cover.

1. Remove the shaft-seal reservoir vented oil filler-plug (Figure 3-2, item 16).
2. Refer to Figure 3-3. Fill the shaft-seal reservoir with PFPE oil until the oil-level is at the recommended oil-level (2) at the top of the reflector plate (6).
3. Refit the vented oil filler-plug.

3.8.3 Rear-bearing end-cover (iQMB1200F only)

1. Refer to Figure 3-2. Remove the oil filler-plug (5) on the top of the rear-bearing end-cover (4); take care not to accidentally remove the plug from the external evacuation port (3).
2. Fill the end-cover with oil until the oil-level is at the middle of the reflector plate in the end-cover oil-level sight-glass (7).
3. Refit the oil filler-plug.

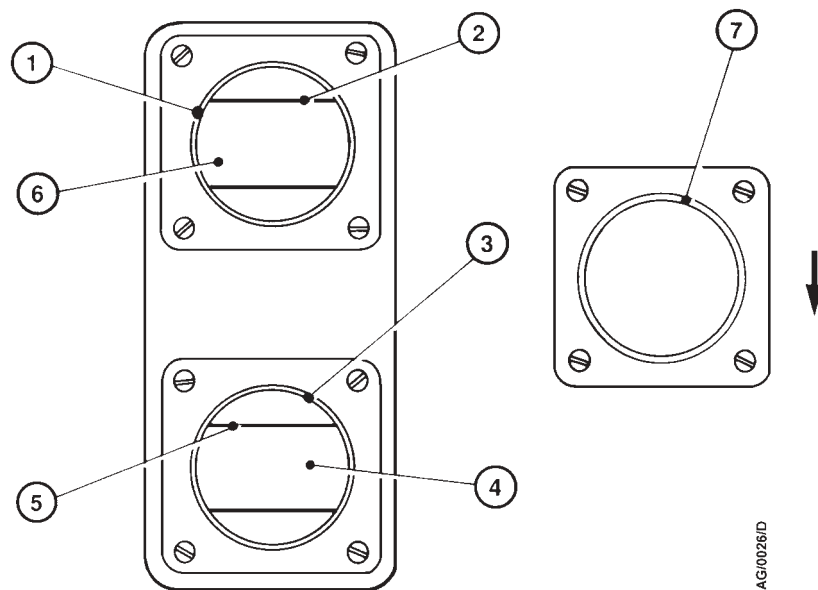

AG/0026/D

1. Shaft-seal reservoir sight-glass
2. Shaft-seal reservoir recommended oil-level
3. Coupling-cover sight-glass
4. Coupling-cover reflector plate
5. Coupling-cover recommended oil-level
6. Shaft-seal reflector plate
7. Direction of rotation sight-glass (the arrow shows the correct direction of rotation)

Figure 3-3 - iQMB pump sight-glasses

3.9 Install or replace optional accessories (if necessary)

3.9.1 Replace the Gas Module

If you want to replace the Gas Module fitted to your iQ system with a different type of Gas Module, replace the Gas Module as described in Section 6.15.

3.9.2 Install the Pump Display Module

1. Refer to Figure 1-10. Fit the connector on the end of the connector cable (5) to one of the module connectors on the front of the iQ system (Figure 1-5, item 6).
2. If you will not fit another Interface Module (as described in Section 3.9.3) or the iQ Single Pumpset Monitor (as described in Section 3.9.4), fit the terminator plug supplied to the other module connector.
3. Place the Pump Display Module in its required operating position.

3.9.3 Install the Interface Module(s)

Install any Interface Module accessories you will use now before you continue installation. Connect an Interface Module accessory to the iQ system and to your control equipment as described in the instruction manual supplied with the accessory.

3.9.4 Install the iQ PC Interface Kit

Install the iQ PC Interface Kit to connect your computer to the iQ system and install the iQ Single Pumpset Monitor software on your computer as described in the instruction manual supplied with the PC Interface Kit.

3.9.5 Install the iQ Water Flow-Switch

Install the iQ Water Flow-Switch accessory on the iQ system as described in the instruction manual supplied with the accessory.

3.10 Check the iQDP pump oil level

Check that the oil-level in the iQDP pump is correct; the oil-level must be between the MIN and MAX marks on the bezel of the oil-level sight-glass (see Figure 3-4). If necessary, drain excess oil from the pump or fill the pump with oil: refer to Section 6.11.

3.11 Check the iQDP pump coolant level

Refer to Figure 3-4.

1. Unscrew and remove the combined filler-plug/level indicator (5). Use a clean lint-free cloth to wipe the shaft of the indicator, then replace the combined filler-plug/level indicator in the coolant header-tank.

(Continued on page 3-12)

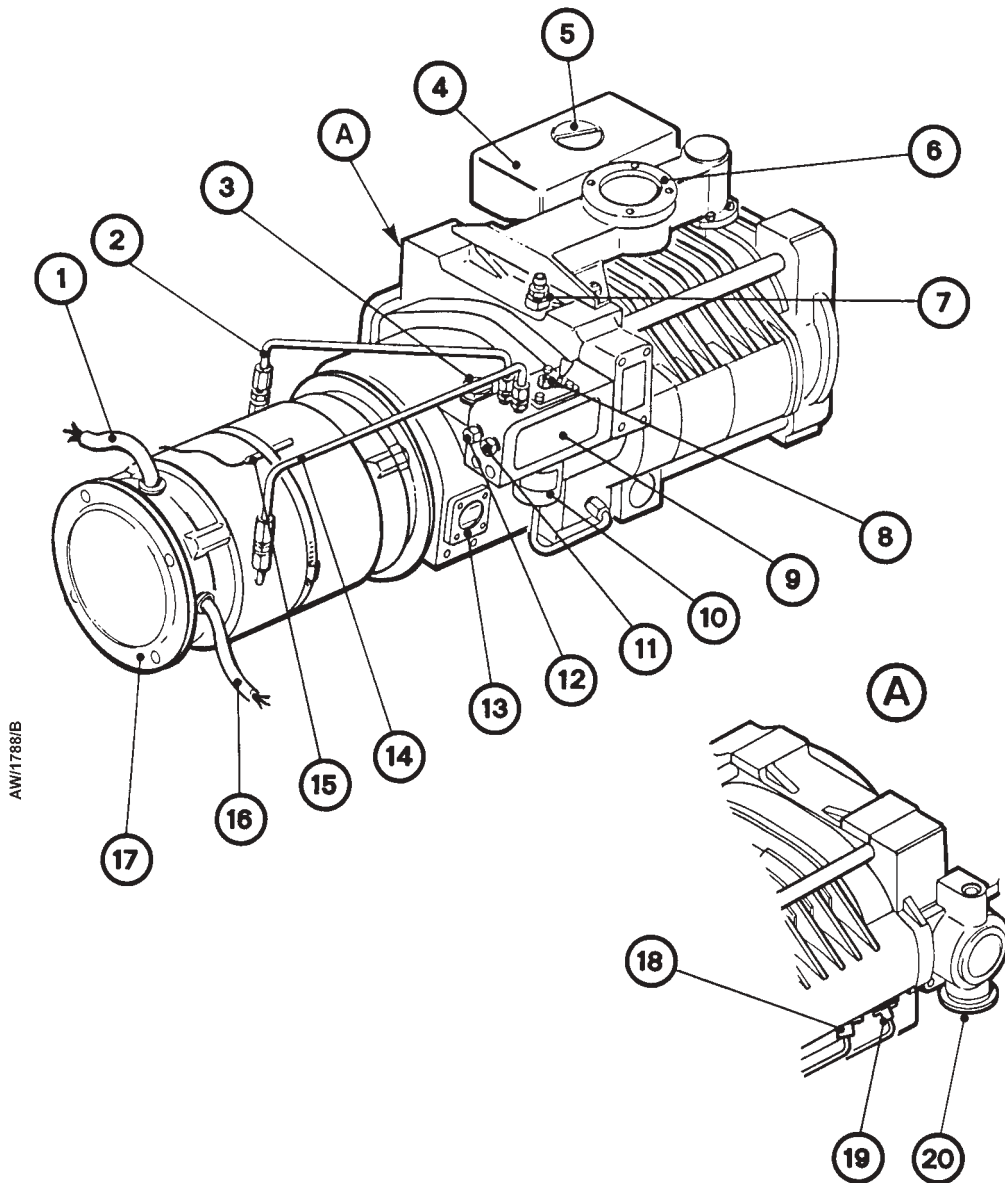

- | | |
|---|---|
| 1. Electrical supply cable | 11. iQMB cooling-water return connector |
| 2. Pump-motor cooling-water pipe | 12. iQMB cooling-water supply connector |
| 3. Oil filler-plug | 13. Oil-level sight-glass |
| 4. Coolant header-tank | 14. Pump-motor cooling-water pipe |
| 5. Combined filler-plug/level indicator | 15. Pump-motor surface temperature sensor |
| 6. Inlet-flange | 16. Thermistors cable |
| 7. Air bleed-valve | 17. Motor terminal-box cover |
| 8. TCV adjuster spindle | 18. Thermal snap-switch |
| 9. Cooling-water manifold | 19. Thermocouple |
| 10. TCV (Thermostatic Control-Valve) | 20. Exhaust outlet |

Figure 3-4 - iQDP pump components

2. Remove the combined filler-plug/level indicator again and check the coolant-level: the coolant-level must be visible on the shaft of the indicator, but must not be above the notch mark on the indicator shaft.
3. If necessary, add more coolant: refer to Section 6.8.
4. Check that the bonded seal on the combined filler-plug/level indicator (5) is in place. Refit and tighten the combined filler-plug/level indicator.

3.12 Connect to your process system

3.12.1 Adjust the height of the system

If you have an iQ system with an iQDP pump only, or if you have an iQ system with a direct mounted iQMB pump, the height of the iQ system inlet from the ground can be lowered by 6 mm. To lower the inlet, remove each of the castors and then remove the spacer plate between each castor and the iQ system frame. Refit the castors with 16 mm long M8 cap-head bolts.

3.12.2 Connect the inlet of the iQ system to your process system

Note: If required (that is, if you will use the iQ system in an area subject to high RF (radio frequency) emissions), connect the end of the iQ earth (ground) cable to one of the bolts that you use to connect the inlet-flange of the iQ system to your vacuum system. See Section 3.19.4 for more information.

When you connect your iQ system to your vacuum system, take note of the following:

- To get the best pumping speed, ensure that the pipeline which connects the vacuum system to the iQ system is the minimum length possible and has an internal diameter not less than the iQ system inlet-port.
 - Use a flexible connection in the pipeline to reduce vibration and stress in the system pipelines.
 - On very dusty applications, use an inlet-filter to minimise damage to the pump.
 - You must be able to isolate the iQ system inlet from the atmosphere and from your vacuum system if you have pumped or produced corrosive chemicals.
 - Vacuum pipelines must be adequately supported to stop the transmission of stress to pipeline joints.
1. If your iQ system only has an iQDP pump (that is, you do not have an iQMB pump on your system), remove the four M8 x 15 mm cap-head bolts, nuts and washers and remove the blanking-plate from the inlet of the iQDP pump.
 2. Retain the nuts, bolts and washers for future use. Retain the blanking-plate for future use as a temporary cover, for uncontaminated pumps only.
 3. Use the 'O' ring or trapped 'O' ring supplied to connect the inlet-flange of the iQ system to your vacuum system. Secure with the bolts provided in the fitting-kit or the bolts removed in Step 1.

3.13 Connect to your exhaust-extraction system

3.13.1 Install the iQ Exhaust Temperature Sensor (optional)

If you will connect the outlet of the iQ system as supplied to your exhaust-extraction system (that is, you will not use the alternative iQ outlet position: see Section 3.13.2), install the iQ Exhaust Temperature Sensor accessory on the iQ system now, as described in the instruction manual supplied with the accessory.

If you will use the alternative iQ outlet position, install the iQ Exhaust Temperature Sensor when you disconnect the inlet of the exhaust-silencer from the outlet of the iQ pump: refer to Section 3.13.2.

3.13.2 Configure the iQ system to use the alternative outlet position

Figure 2-1 shows the positions of the iQ system outlet; as supplied, the outlet is at the motor end of the iQDP pump. If necessary, you can move the outlet to the opposite end of the iQDP pump. Use the following procedure to use the alternative outlet position.

1. Remove the two screws (Figure 1-5, item 10) which secure the exhaust-silencer support-plate to the pump and remove the support-plate.
2. Undo and remove the NW40 clamp which secures the inlet of the exhaust-silencer to the exhaust outlet of the iQDP pump (Figure 3-4, item 20).
3. Remove the exhaust-silencer and turn it through 180°, so that the outlet is at the other end of the iQDP pump (as in Figure 2-1).
4. If required, you can remove the adaptor (Figure 2-1, item 3) from the exhaust-silencer on the iQDP80 pump. To remove the adaptor:
 - Remove the two NW40 clamps which secure the adaptor to the outlet of the exhaust-silencer and the elbow and remove the adaptor.
 - Use one of the clamps to secure the elbow to the outlet of the exhaust-silencer.
5. Use the clamp removed in Step 2 to secure the inlet of the exhaust-silencer to the outlet of the iQDP pump (Figure 3-4, item 20).
6. Refit the exhaust-silencer support-plate and secure with the two screws removed in Step 1.

3.13.3 Connect the iQ outlet to your exhaust-extraction system

WARNING

Pipe the exhaust to a suitable treatment plant to prevent the discharge of dangerous gases or vapours to the surrounding atmosphere.

WARNING

Do not operate the iQ system with the exhaust pipeline blocked. If the exhaust pipeline is blocked, the iQ system can generate exhaust pipeline pressures up to 7 bar (7×10^5 Pa)

CAUTION

Use a catchpot to prevent the drainage of condensate back into the iQ system. Condensate which drains back into the iQ system could damage the iQDP pump.

When you connect to your exhaust-extraction system, take note of the following:

- Ensure that all components in the exhaust pipeline have a maximum pressure rating which is greater than the highest pressure that can be generated in your system.
 - Incorporate flexible pipelines in the exhaust pipeline to reduce the transmission of vibration and to prevent loading of coupling-joints. We recommend that you use BOC Edwards braided flexible pipelines.
 - You must be able to isolate the exhaust check-valve outlet from the atmosphere if you have pumped or produced corrosive chemicals.
 - You must support exhaust pipelines to stop the transmission of stress to pipeline joints.
1. Remove the plastic cover from the flange on the exhaust check-valve outlet and retain for future use as a temporary cover, for uncontaminated pumps only.
 2. Connect the exhaust check-valve outlet to your exhaust system. The outlet has an NW40 flange.

3.14 Connect the nitrogen supply

CAUTION

Ensure that your nitrogen supply conforms to the requirements given in Section 2. If it does not, the flow sensors may not operate correctly, the gas pipelines may become blocked or the pump may be damaged.

Connect your nitrogen supply to the iQ system through the nitrogen supply connector on the Gas Module (see Figures 3-11 and 3-12).

Use rigid metal supply pipelines (such as stainless steel) with an outside diameter of $1/4$ inch. If you have an acoustic enclosure to fit, ensure that the pipelines will not obstruct the enclosure. Use the connectors in the fitting-kit to connect your pipeline to the iQ system.

3.15 Leak test the system

WARNING

Leak-test the system after installation and maintenance and seal any leaks found to prevent leakage of dangerous substances out of the system and leakage of air into the system.

Leak-test the system after installation and seal any leaks found. Dangerous substances which leak from the system will be dangerous to people and there may be a danger of explosion if air leaks into the system. We recommend that the leak rate is 1×10^{-5} mbar $l s^{-1}$ (1×10^{-3} Pa $l s^{-1}$) helium or less.

3.16 Install additional safety equipment (optional)

WARNING

If you need to know the total flow rate of nitrogen to the iQ system for safety reasons, install suitable measurement equipment in the nitrogen supply pipeline.

WARNING

If you use the nitrogen purges to dilute dangerous gases to a safe level, ensure that the system shuts down if the nitrogen supply to the iQ system fails.

If the sensors or microprocessor fail, the total flow rate of nitrogen displayed or output by the iQ system may be incorrect. If you need to know the total flow rate of nitrogen to the pump for safety reasons, you should therefore fit suitable measurement equipment in the nitrogen supply pipeline. If you fit a rotameter, ensure that it is suitable for use with nitrogen and that it is correctly calibrated.

If the nitrogen supply to the iQ system fails, a warning message will be shown on the Pump Display Module and will be sent to the Interface Module(s) connected to the iQ system. Ensure that your installation is configured so that it remains safe if there is a failure of the nitrogen supply to the iQ system.

If an alarm condition is detected (and the iQ system is not configured to 'run til crash': see Section 5.11) the pump will shut down automatically. You must ensure that your installation remains safe if the iQ system shuts down automatically.

3.17 Connect to your emergency stop circuit (optional)

Note: If you do not connect to your own control equipment, you must fit the emergency stop connector mating-half supplied to the external emergency stop on the Electrics Module. If you do not, you will not be able to operate the iQ system.

If required, you can connect your own control equipment to the iQ system to shut down the iQ system in an emergency. Use the following procedure:

1. Remove the link between pins 1 and 2 of the external emergency stop connector mating-half supplied.
2. Connect a suitable cable to the external emergency stop connector mating-half; Table 3-5 shows the use of the pins in the connector.
3. Refer to Figure 1-7. Fit the connector mating-half to the external emergency stop connector (11) on the rear of the Electrics Module.

Pin(s)	Use
1 and 2	Linked as supplied. Remove the link and connect these pins to your normally-closed, isolated external emergency stop circuit.
3 and 4	Isolated auxiliary contacts of the emergency stop switch on the Electrics Module (Figure 1-5, item 4).
5	24 V a.c. continuous output; maximum current 625 mA
6	0 V return

Table 3-5 - Pins in the emergency stop connector

3.18 Connect the GRC bypass output to your GRC (optional)

If you have a BOC Edwards GRC (Gas Reactor Column) connected to the outlet of the iQ system, you can connect the GRC bypass output to the GRC, to open the GRC bypass-valve when you start the iQ system. Use the following procedure:

1. Connect a suitable cable to the GRC bypass connector supplied with the GRC; use the pins in the connector as shown in Table 3-6.
2. Refer to Figure 1-7. Fit the connector mating-half to the GRC bypass connector (5) on the rear of the Electrics Module.
3. Connect the other end of the cable to the remote input connector on the GRC: refer to the GRC instruction manual.

Pin	Use
3	Common
4	Normally closed
5	Normally open

Table 3-6 - Pins in the GRC bypass connector

3.19 Electrical supply and RF earth (ground) connections

3.19.1 Configure the Electrics Module for your electrical supply

As supplied the transformer tapplings in the Electrics Module are configured for a 208 V 50/60 Hz electrical supply. You must ensure that the correct transformer primary tapping is selected for your electrical supply before you connect the electrical supply to the Electrics Module.

Refer to Figure 3-5 and use the following procedure.

1. Undo the screws (2) which secure the cover (3) of the Electrics Module (1) and remove the cover.
2. Ensure that the voltage select cable (5) is connected to the correct terminal of the terminal-block (4) for your electrical supply.
3. Refit the cover (3) and secure with the screws (2).

3.19.2 Configure the pump(s) for your electrical supply

Note: If you reconfigure the motors, ensure that the phase wires L1, L2 and L3 are connected to the correct terminals (U1, V1 and W1) in the motor terminal box(es). If they are not, the iQ system will not start and an alarm message will be displayed: refer to Section 6.

The universal voltage and frequency motors can be supplied configured for 'low voltage' operation (200-208 V at 50 Hz or 200-230 V at 60 Hz) or 'high voltage' operation (380-415 V at 50 Hz or 460 V at 60 Hz). The iQ system will normally be supplied with the pump-motor(s) configured for your electrical supply. If you need to reconfigure the pump-motors:

1. Refer to Figure 1-5. Remove the four screws which secure the front panel (7) and remove the front panel.
2. Remove the pump-motor terminal box covers (Figure 3-2, item 13 and Figure 3-4, item 17)
3. To reconfigure the iQDP40, iQMB250F and iQMB500F pump-motors, remove the three links and refit in the correct configuration: see Figures 3-6 and 3-7.
4. To reconfigure the iQDP80 and iQMB1200F pump-motors, remove the wires from the W2, U2, V2, U1, V1 and W1 terminals as appropriate. Reconnect the wires to the terminals in the correct configuration: see Figures 3-8 and 3-9.
5. Refit the pump-motor terminal-box covers.
6. Refer to Figure 1-5. Refit the front panel (7) and secure with the four screws.

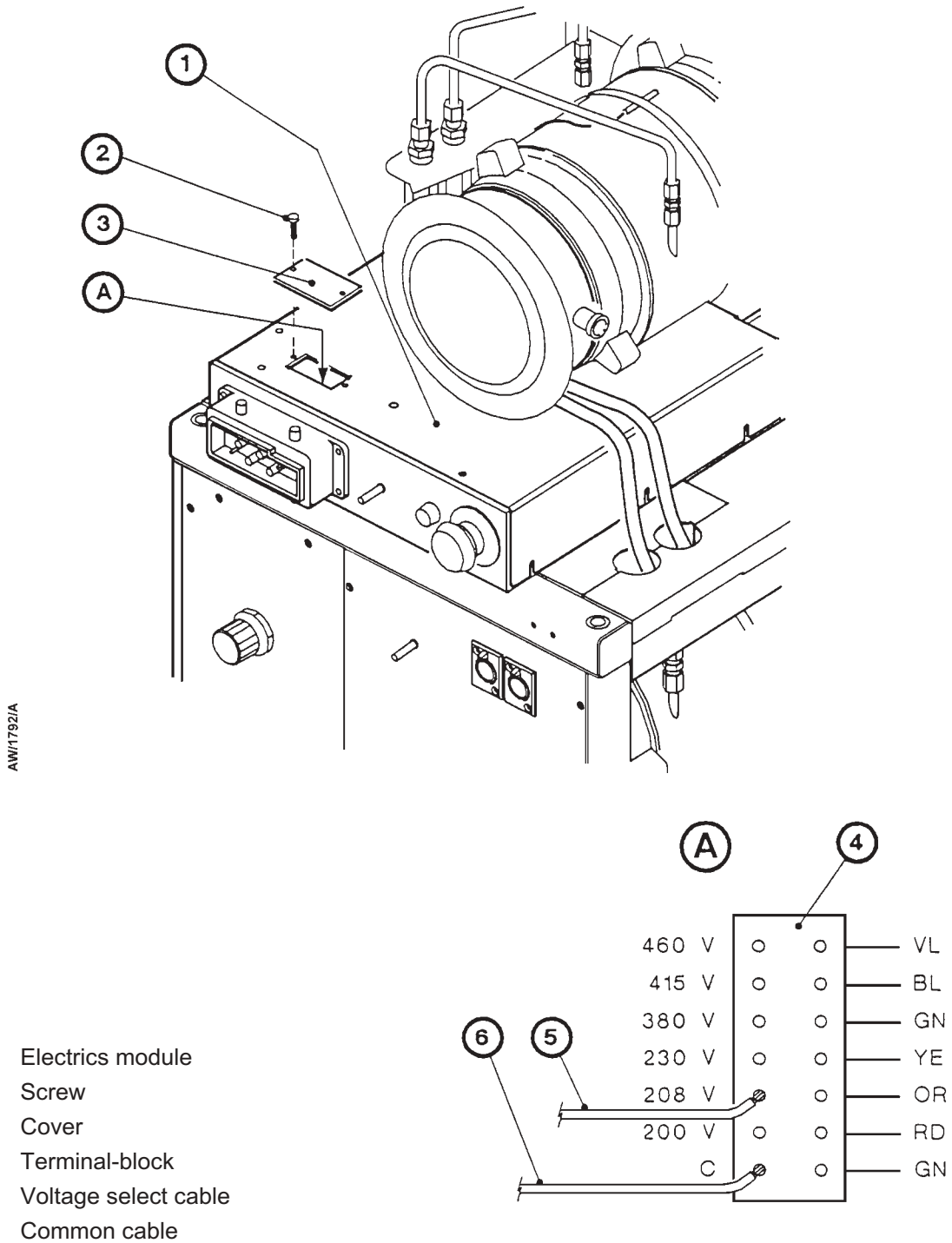

- 1. Electrics module
- 2. Screw
- 3. Cover
- 4. Terminal-block
- 5. Voltage select cable
- 6. Common cable

Figure 3-5 - Configure the Electrics Module

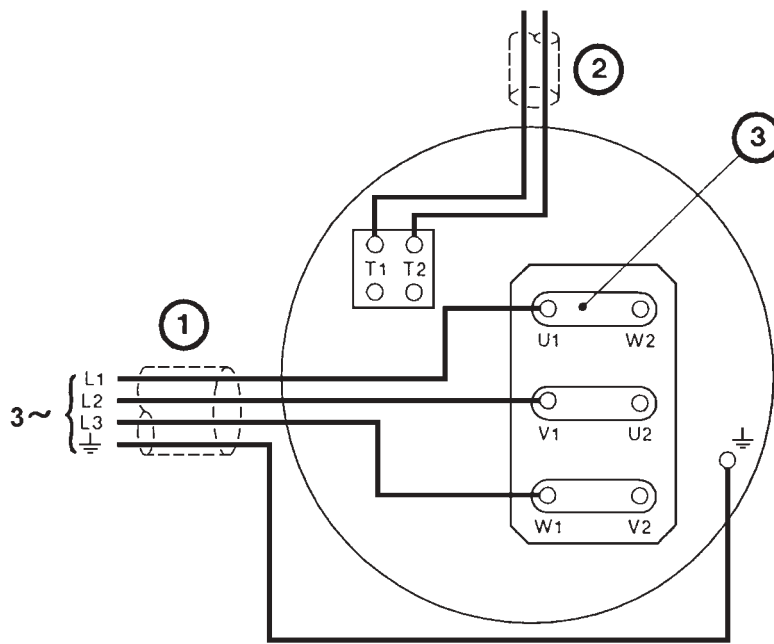

AWI1897/A

1. Electrical supply cable
2. Pump-motor thermistors cable (to Electrics Module)
3. Links

Figure 3-6 - iQDP40 and iQMB250/500F low voltage configuration

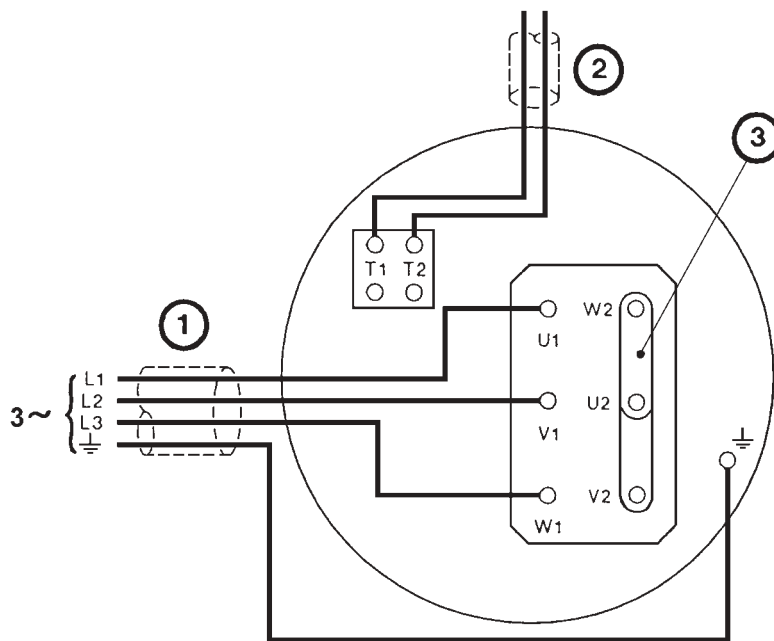

AWI1898/A

1. Electrical supply cable
2. Pump-motor thermistors cable (to Electrics Module)
3. Links

Figure 3-7 - iQDP40 and iQMB250/500F high voltage configuration

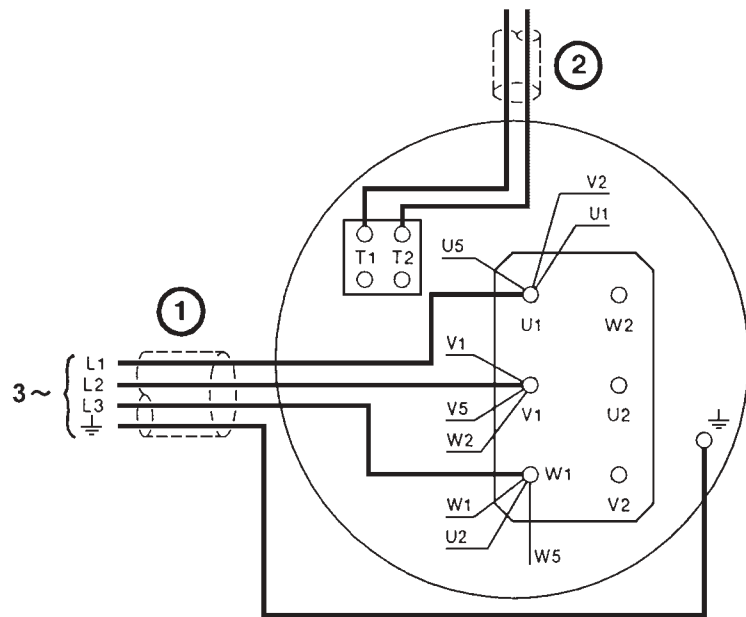

AW/1899/A

1. Electrical supply cable
2. Pump-motor thermistors cable (to Electrics Module)

Figure 3-8 - iQDP80 and iQMB1200F low voltage configuration

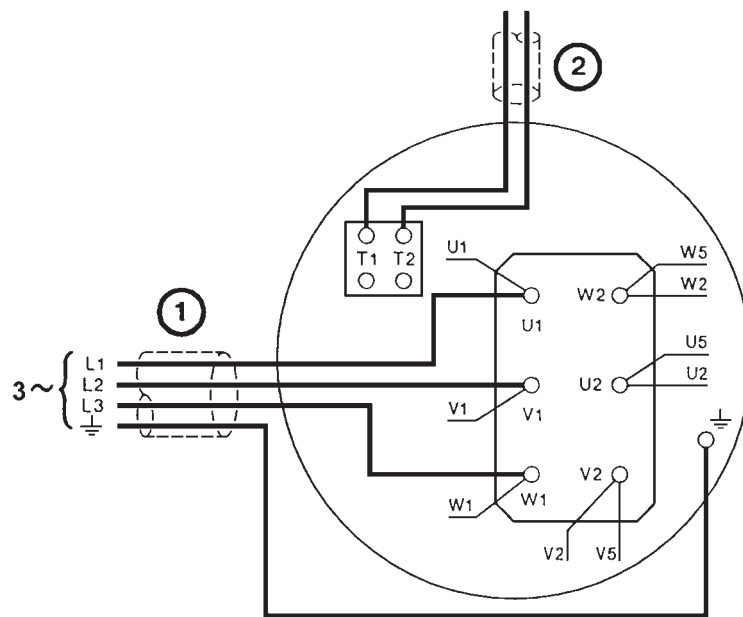

AW/1900/A

1. Electrical supply cable
2. Pump-motor thermistors cable (to Electrics Module)

Figure 3-9 - iQDP80 and iQMB1200F high voltage configuration

3.19.3 Connect the electrical supply

WARNING

Connect the iQ system to the electrical supply through a suitably rated isolator for your iQ system (refer to Section 2).

WARNING

Ensure that your electrical supply cable is suitably protected against earth (ground) faults and that the earth (ground) conductor of the cable is longer than the phase conductors in the connector. You may want to fit a second earth (ground) conductor to the earth (ground) stud on the Electrics Module.

Note: If you do not fit a second earth (ground) conductor, you must regularly check the earth (ground) continuity of the installation.

Use the following procedure to connect the electrical supply to the iQ system.

Refer to Figure 3-10. The electrical connector kit supplied with the iQ system comprises a connector hood (7), a connector block (8), a cable-gland body and five seal inserts of different sizes. The cable-gland body and the seal inserts are supplied together in a single bag. You must select and use the correct size of seal insert for your electrical supply cable; that is you must use the seal insert that will only just fit onto the cable. If you use a larger size of seal insert, it will not adequately grip the cable, and it may allow moisture to penetrate into the interior of the connector assembly.

When you make your electrical supply cable, ensure that the earth (ground) conductor is longer than the phase conductors. This will ensure that if the cable is accidentally dragged and the strain relief on the electrical supply connector mating-half cable-gland fails, the earth (ground) conductor will be the last conductor to be pulled from the connector.

1. Refer to Figure 3-10. Remove the connector block (8) from the hood (7) of the mating-half electrical supply connector.
2. Remove the locking nut (5) from the cable-gland and pass the end of your electrical supply cable (6) through the nut.
3. Select the most suitable size of seal insert (see above), then pass the end of your electrical supply cable (6) through the seal insert, with the knurled face of the insert towards the end of the cable.
4. Fit the cable-gland body to the hood (7). Ensure that it is securely fitted, then push the end of the electrical supply cable (6) through the cable-gland body and push the seal insert fully into the cable-gland body.
5. Screw the locking nut (5) onto the cable-gland, but do not fully tighten it yet.

(Continued on page 3-22).

6. Connect the cable phase conductors to the pins in the connector block (8) as shown in Table 3-7.
7. Connect the earth (ground) conductor of the cable to one of the two earth (ground) screws (4) on the side of the connector block (8).
8. Refit the connector block (8) into the hood (7), then tighten the locking nut (5) on the cable-gland.
9. Fit the mating-half assembly to the electrical supply connector (9) on the Electrics Module.
10. Connect the other end of the electrical supply cable to your electrical supply through a suitable isolator.
11. We recommend that you fit a second earth (ground) conductor to the earth (ground) stud on the front of the Electrics Module (Figure 1-5, item 2) and connect the other end of this conductor to your factory earth (ground).

Wire	Pin number (Figure 3-10 key)
Phase 1	1
Phase 2	2
Phase 3	3

Table 3-7 - Pins in the electrical supply connector

3.19.4 Connect an additional RF earth (ground): optional

An earth (ground) cable is connected to the rear of the M6 RF earth (ground) stud on the front panel (Figure 1-5, item 5). If you will operate the iQ system in an area subject to high RF (radio frequency) emissions, in accordance with good RF installation practise, we recommend that you:

- Use a star washer to connect the end of this cable to one of the bolts that you use to secure the inlet-flange (se Section 3.12.2).
- Connect an additional earth (ground) cable to the M6 RF earth (ground) stud. You must use a suitable low-impedance cable (for example, use braided cable).

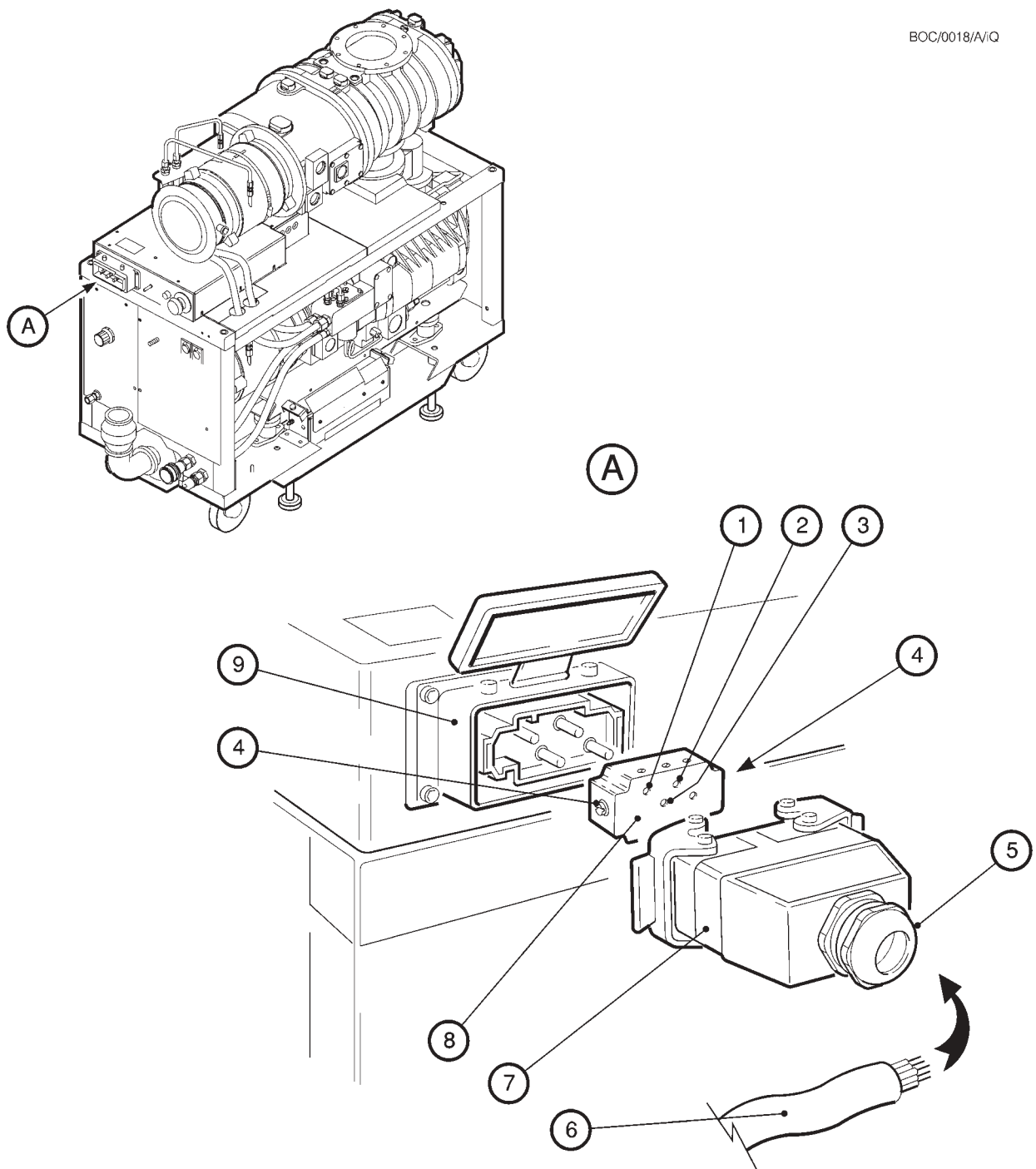

- | | |
|----------------------------|--------------------------------|
| 1. Pin 1 (phase 1) | 6. Electrical supply cable |
| 2. Pin 2 (phase 2) | 7. Hood |
| 3. Pin 3 (phase 3) | 8. Connector block |
| 4. Earth (ground) screw | 9. Electrical supply connector |
| 5. Cable-gland locking nut | |

Figure 3-10 - Connect the electrical supply cable to the connector mating-half

3.20 Connect the cooling-water pipelines

WARNING

Do not turn on the cooling-water supply until after you complete the electrical installation of the pump. If you do, condensation may form inside the motor terminal-box and there may be a risk of electric shock.

CAUTION

Drain the cooling-water from the pumping system, if you will transport or store it in conditions where the cooling water could freeze. If you do not, cooling-water may freeze in the pumping system and damage the pump(s).

Notes: For optimum water-cooling, ensure that your cooling-water supply and return hoses are free of restrictions which would reduce the cooling-water flow rate. If you need to connect more than one iQ system to the water supply, you must connect them in parallel and not in series.

If you will transport or store the pumping system in conditions where the cooling-water could freeze, you must ensure that all cooling-water is drained from the pumping system: refer to Section 7.1.

Connect the cooling-water supply as described below. If you have fitted a iQMB mechanical booster pump to your iQ system, you should have connected the iQMB cooling-water supply and return hoses to the cooling-water manifold on the iQDP pump as described in the instruction manual supplied with the iQMB Connection Kit. When you connect the hoses between the iQDP cooling-water manifold and the iQMB pump, remove only the $\frac{3}{8}$ BSP caps on the iQDP manifold. Do not remove the $\frac{3}{8}$ to $\frac{1}{4}$ inch reducer fittings on the manifold.

1. Use $\frac{3}{8}$ inch BSP male pipe fittings (which you must supply) to fit the female quick-release connector to the cooling-water supply hose and to fit the male connector to the cooling-water return hose.
2. Remove the dust-caps from the cooling-water connectors on the iQDP water services panel (Figure 1-5, items 8 and 9).
3. Connect your water supply hose to the water supply connector (9) on the water services panel and connect your water-return pipe to the water-return connector (8) on the iQ system.
4. Turn on the cooling-water supply.
5. To bleed air out of the water cooling system, use a screwdriver to lift up the spindle on the top of the TCV (Figure 3-4, item 8) and hold it up for 15 to 30 seconds to allow a steady flow of water to establish. Do not turn the spindle against the locking-wire.
6. Inspect the water hoses, pipelines and connections and check that there are no leaks.
7. Turn off the water supply while you complete the remainder of the installation procedures.

3.21 Adjust the interstage purge flow rates if necessary

The 3/4-interstage purge flow rate is preset for correct operation in Gas Ballast and Gas System Modules. The 2/3-interstage purge flow rate is preset for correct operation in the Gas System Module. If necessary, these purge flow rates can be adjusted: contact your supplier or BOC Edwards for advice.

3.22 Commission the iQ system

3.22.1 Switch on the iQ system pumps

Note: If the electrical supply connector mating-half is incorrectly wired, the iQ system will start up (and the pump will rotate in the wrong direction) and will then stop again after a few seconds. To prevent significant pressurisation of your vacuum system in a failure condition, disconnect the inlet of the iQ system from the vacuum system before you first switch on the iQ system.

1. Switch on the cooling-water supply.
2. Ensure that the exhaust-extraction system is not blocked (for example, that valves in the exhaust-extraction system are open).
3. Start up the iQDP pump: refer to Section 5.6.
4. If the iQ system starts and continues to operate, continue at Step 5. If a warning or alarm condition is indicated (for example, a warning or alarm message is shown on the Pump Display Module):
 - Shut down the iQ system: refer to Section 5.10.
 - Refer to Section 6 to determine the cause of the fault and to rectify the fault.
5. If you have an iQ system with an iQMB pump,;
 - Look at the direction of rotation sight-glass (Figure 3-2, item 10), while you switch on the iQMB pump for two or three seconds, then switch off the iQMB pump.
 - If the direction of rotation is correct (as shown by the arrow next to the sight-glass), continue at Step 6.
If the iQMB rotors remain stationary or rotate in the incorrect direction, the iQMB pump-motor terminal-box is incorrectly wired: shut down the iQ system, correct the electrical wiring (see section 3.19.2), then repeat this procedure from Step 2 again.
6. Check the nitrogen pressure and adjust if necessary:
 - If you have a Shaft-Seals Purge Module, refer to Section 3.22.2.
 - If you have a Gas-Ballast Module or a Gas System Module Series 2, refer to Section 3.22.3.
7. If required, adjust the operating temperature of the iQ pump as described in Section 3.22.4.
8. After you have commissioned the iQ system:
 - If you want to continue to operate the iQ system, refer to Section 5.
 - Otherwise, shut down the system,; refer to Section 5.10.

3.22.2 Check the nitrogen pressure and adjust if necessary (Shaft-Seals Purge Module)

Refer to Figure 3-11. To adjust the nitrogen pressure to the shaft-seals, watch the pressure gauge (2) and turn the pressure regulator (3) until a pressure of 10 psig is shown on the pressure gauge.

3.22.3 Check the nitrogen pressure and adjust if necessary (Gas-Ballast Module and Gas System Module Series 2)

Note: If you have a Pump Display Module, use the Status menu to select SS PURGE display (refer to Section 5), then watch the displayed pressure instead of the pressure LEDs on the Gas Module.

Refer to Figure 3-12. The front of the Gas-Ballast Module and the Gas System Module Series 2 have three pressure LEDs: the yellow pressure warning LED (1), a green pressure low LED (8) and a green pressure high LED (2). Use the pressure regulator (3) to adjust the nitrogen pressure as follows:

- Turn the pressure regulator (3) clockwise to increase the pressure.
- Turn the pressure regulator (3) anticlockwise to decrease the pressure.

After you have turned the pressure regulator, wait for approximately 15 seconds to allow the pressure to stabilise before you look at the pressure LEDs.

Use the following procedure to adjust the nitrogen pressure. Refer to Section 5 for the use of the Pump Display Module menus.

1. Adjust the pressure regulator (3) until the yellow pressure warning LED is off and the two green LEDs are on. Alternatively, if you have a Pump Display Module, use the Status menu to select SS PURGE display, then adjust the pressure regulator (3) until the display shows a pressure of 6.0 psi.
2. Use the Setup/Manual/Inlet Purge menu to turn on inlet purge and gas-ballast purge.
3. Wait at least 4 seconds, then use the same menu to turn off inlet purge and gas-ballast purge.
4. Wait at least 4 seconds, then use the same menu to turn on gas-ballast purge again.
5. Repeat Step 1 of this procedure to set the nitrogen pressure.

3.22.4 Adjust the iQDP pump operating temperature (optional)

CAUTION

Do not adjust the TCV to a lower setting (that is, turn the adjuster spindle anticlockwise) when the iQDP pump is hot. This will increase the flow of cooling-water which may damage the pump because of the differential contraction of the pump rotor and case.

Note: When you adjust the operating temperature of the iQDP pump, ensure that you adjust the setpoints to give warning indications and to shut down the iQ system at the correct temperatures.

The TCV regulates the flow of water through the water cooling system to maintain the iQDP pump at the required operating temperature.

A pump operating temperature of 70 °C is suitable for most processes and, as supplied, the TCV is factory set to maintain this temperature. The adjuster spindle on the TCV is held at this setting by a locking-wire. You can adjust the TCV to vary the operating temperature of the pump between approximately 55 °C (minimum) and approximately 90 °C (maximum). Note that the final operating temperature of the pump depends on the temperature of your cooling-water supply.

Adjust the operating temperature to suit your process:

- For processes which produce condensable by-products, you should increase the operating temperature of the pump.
- For LPCVD nitride processes, we recommend that you set the operating temperature to 80 °C. Note that the iQ system is supplied with the pump-body temperature high warning setpoint set to 88 °C; this setpoint is suitable for LPCVD nitride operation.
- For processes which require the pump to operate at the lowest possible temperature (for example, tungsten based processes), we recommend that you set the operating temperature to 55 °C, adjust the pump-body temperature low warning setpoint to 45 °C and adjust the pump-body temperature high warning setpoint to 65 °C (refer to Section 5.3).

To adjust the TCV to suit your operating conditions, refer to Figure 3-4 and use the following procedure. Note that it takes approximately 30 minutes for the pump to stabilise at its final operating temperature.

1. If you have a Pump Display Module, select the iQDP pump temperature display option of the Status menu: refer to Section 5. The pump temperature will then be shown on the display.
2. Cut and remove the locking-wire on the spindle on the top of the TCV (8).
3. Use a suitable screwdriver to turn the spindle (8) the necessary number of turns from the factory set position to select the required operating temperature (refer to Table 3-8 for the iQDP40 and Table 3-9 for the iQDP80). If you are not sure whether the adjuster spindle is at the factory set position, turn the spindle fully clockwise until it will turn no further, then adjust the spindle from this position.

(Continued on page 3-30)

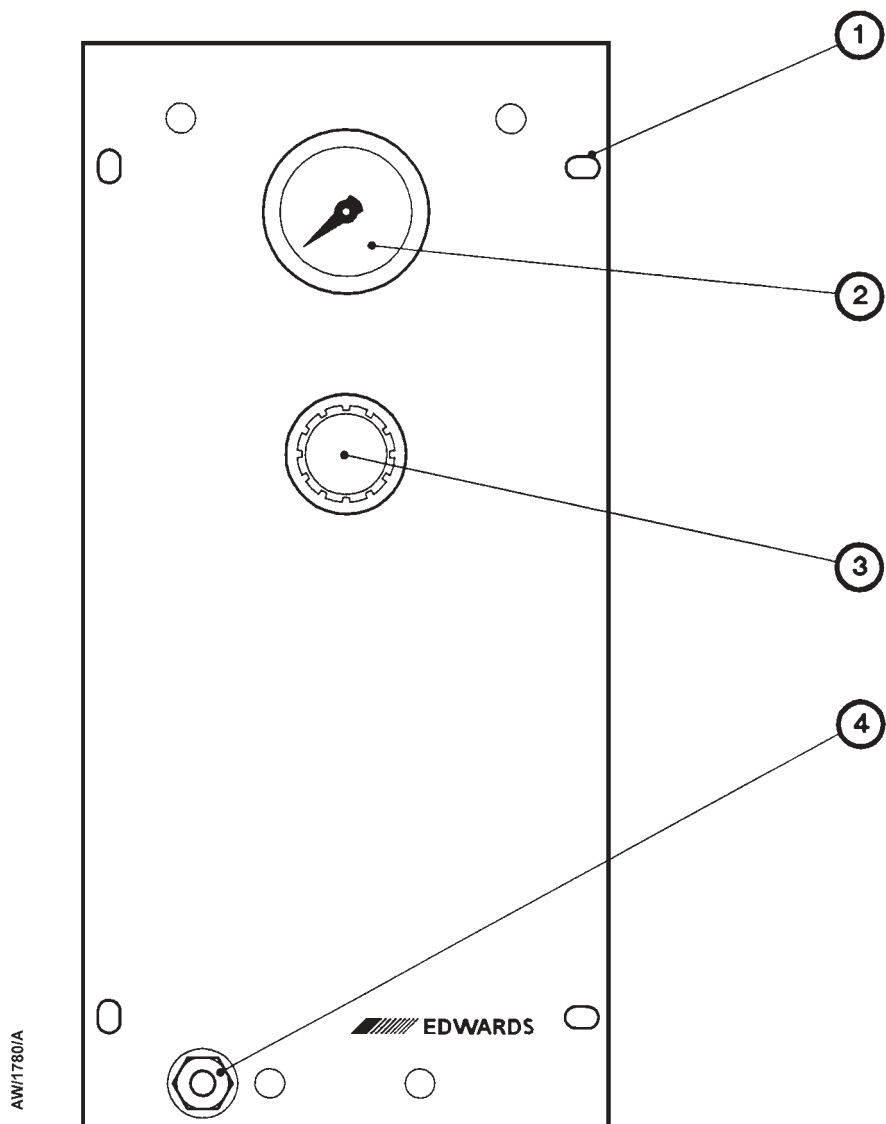

1. Fixing-holes (4 off)
2. Pressure gauge
3. Pressure regulator
4. Nitrogen supply connector

Figure 3-11 - Front panel of the Shaft-Seals Purge Module

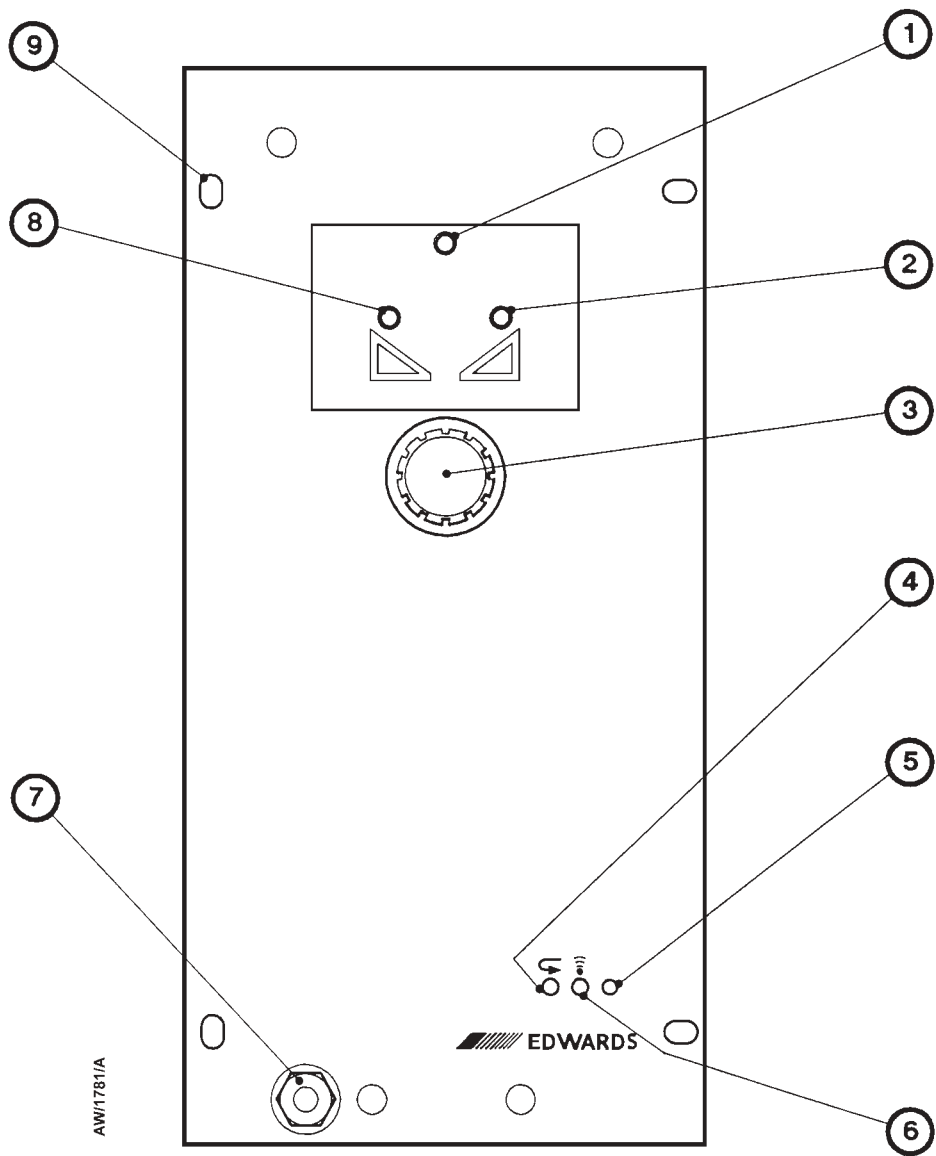

- | | |
|----------------------------------|------------------------------|
| 1. Pressure warning LED (yellow) | 6. Service button |
| 2. Pressure high LED (green) | 7. Nitrogen supply connector |
| 3. Pressure regulator | 8. Pressure low LED (green) |
| 4. Default button | 9. Fixing-holes (4 off) |
| 5. Service LED | |

Figure 3-12 - Front panel of the Gas-Ballast Module and the Gas System Module Series 2

4. Look at the pump temperature shown on the Pump Display Module. If necessary, repeat this procedure from Step 3 to further adjust the operating temperature.

3.23 Fit the Acoustic Enclosure (optional)

Fit the Acoustic Enclosure as described in the instruction manual supplied with the Acoustic Enclosure.

Required iQDP pump operating temperature °C	Required number of turns of TCV adjuster spindle	
	From factory set position	From fully clockwise position
Valve shut/pump off	10	-
90	9	1
70 *	-	10
55	6	16

} Clockwise } Anti-clockwise

* Factory set position

Table 3-8 - Adjust the TCV on the iQDP40

Required iQDP pump operating temperature °C	Required number of turns of TCV adjuster spindle	
	From factory set position	From fully clockwise position
Valve shut/pump off	13	-
90	9	4
70 *	-	13
55	8	21

} Clockwise } Anti-clockwise

* Factory set position

Table 3-9 - Adjust the TCV on the iQDP80

4 PUMP DISPLAY MODULE MENUS AND DISPLAY FORMATS

4.1 Introduction

The menus used and the display messages shown on the Pump Display Module are described in the menu diagrams in Figures 4-1 to 4-21. The following symbols and conventions are used in the menu diagrams:

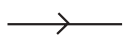

These are flow lines. Arrows on the lines show the direction of flow through a menu.

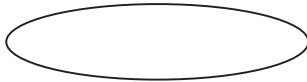

This symbol is used to connect different menus and shows the starting point (or continuation point) of a menu. The symbol is shown with the menu name and, where applicable, a reference of the form [4-x/y]. This reference specifies that the menu continues on (or is continued from) a menu shown on sheet y of Figure 4-x. The sheet reference (/y) is omitted where it is not necessary.



This symbol is used for the ENTER and CANCEL buttons and the four menu buttons: Normal, Status, Control and Setup.



This symbol is used for the up (▲) and down (▼) buttons and for the on (◀▶) and off (⊖) buttons.



This symbol is used for the two-line display on the Pump Display Module. With the exception of variable text (see Section 4.4), the text shown in the symbol is the text that will be shown on the display.

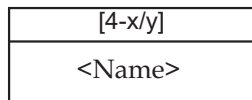

This symbol is a subroutine box and is used to represent a 'subroutine call'; a subroutine is a series of menu steps which are used in a number of different menus or used in different parts of one menu. The [4-x/y] reference (used as described above) shows where the subroutine is expanded.

In a menu which 'calls' a subroutine, where a menu flow line meets the left hand side of a subroutine box, this means that flow continues at the start connector (identified by <name>) of the subroutine. At the 'exit' connector of the subroutine, flow continues in the (calling) menu along the flow line to the right of the subroutine box.

This symbol shows additional text which is not part of the menu, but which further describes the operation of the menu.

4.2 General operation

When you first switch on the iQ system, the normal display is shown: see Figure 4-4. You can then press the On or Off button or any of the four menu buttons to enter the corresponding menu. Then, regardless of the current menu and display status, when you press any of these buttons, you exit the current menu and enter the corresponding new menu. Figure 4-1 shows this menu control logic.

4.3 The CANCEL button

You can press the CANCEL button at any time during menu operation. For this reason, we have not shown the use of the CANCEL button on all of the menu diagrams, but we have shown specific uses where there is no other obvious way to cancel the current menu option and enter the previous menu option. In general, when you press the CANCEL button, the current menu option is cancelled and the previous menu option is displayed. Other specific uses of the CANCEL button are as follows:

- In the Switch On and Switch Off menus (Figures 4-2 and 4-3), when you press CANCEL, the menu is exited and the normal display is shown.
- In the Status menu (Figure 4-5), when you press CANCEL the display shows the first two status parameters (the defaults are iQDP current consumption and power consumption).
- When you change passwords in the Setup and Service menus (Figures 4-7 and 4-14), and when you change serial numbers in the Service menu, if you press CANCEL before you enter the amended value, the menu moves back to entry of the previous digit of the password or serial number.
- When you change a new setpoint value in the Setpoint menu (Figure 4-10), or when you change the timeout time (Figure 4-12), if you press CANCEL before you enter the amended value, the value changes to its default value.

4.4 Display text and variable text

In the menu diagrams in Figures 4-1 to 4-21, text shown without chevron brackets in the two-line display symbol is the actual text that will be shown on the display. In this text, the 'Δ' symbol is used to show where a digit will be shown; the value of the digit depends on the sensor data or information you enter into the Pump Display Module.

Text enclosed in chevron brackets (for example, <status>) defines variable text; what is shown on the display depends on the menu or the status of the iQ system and data entered by the user. The following variable text markers are used on the menu diagrams:

- | | |
|----------|--|
| <status> | This specifies the status of a sensor in the iQ (an Oil-Level Monitor or Water Flow-Switch) or a gate valve. <status> for a sensor can be OK, NP (not present, i.e. not fitted) or LOW; <status> for a gate valve indicates whether the valve is open or closed. |
| <tag> | This specifies the user tag. The user tag is a number which you can use to identify the iQ system in the installation. |

<parameter>	This is a previously selected parameter or menu option.
<message>	This specifies a warning, alarm or advisory message.
<e.no>	This specifies an error number: refer to Section 6.
<units>	This specifies setpoint units, for example kW or slm.

4.5 Wrap-around

When you use the up and down buttons to change a digit or character on the display, the digit or character will 'wrap-around' between its minimum and maximum values. For example, when you enter a password digit, if the digit is '0' and you press the down button, the digit will change to '9'; if the digit is '9' and you press the up button, the digit will change to '0'.

4.6 Timeout

As supplied, after you have entered a menu (other than the Normal menu), if you do not press a button for five minutes, the Pump Display Module will automatically exit the current menu and enter the Normal menu. This facility (known as timeout) is available so that if the setup or service menu is entered and then the iQ system is accidentally left unattended for a specified time, the menu is exited to prevent unauthorised use of the menu options.

You can vary the timeout time between 1 and 200 minutes: refer to Figure 4-12. If you set the timeout time to 0 minutes, this switches off the timeout facility, and the current menu will remain displayed continuously, until you select another menu.

4.7 Menu structure

The menu structure is shown in Table 4-1. Note that if a particular system component or accessory is not fitted, the corresponding menu option or parameter is not shown or is shown as 'NP' (not present).

For example: in the Status menu (Figure 4-5), if a component is not fitted, 'NP' (not present) is shown in the corresponding display line. That is, if you do not have an oil-level monitor fitted to the iQMB pump, where Figure 4-5 shows the 'QMB OIL' status display, the actual display line will be 'QMB OIL NP'.

4.8 Example

Here is an example of how to interpret the menu diagrams. The following procedure describes how to change the units displayed for pressures (you can select kPa or psi).

1. Press the Setup button to enter the Setup menu (Figure 4-7).
2. Use the up and down buttons to change the first digit of the setup password to the correct value, then press the ENTER button.
3. Use the up and down buttons to change the second digit of the setup password to the correct value, then press the ENTER button.

(Continued on page 4-4)

4. Use the up and down buttons to change the third digit of the setup password to the correct value, then press the ENTER button.
5. If you have entered the correct password, the display will then show 'SETUP MENU' on the top line and 'Inlet Purge' on the bottom line.
6. Press the down button six times or press the up button five times; the display will then show 'SETUP MENU' on the top line and 'Units' on the bottom line.
7. Press the ENTER button; the display will then show 'Units Select' on the top line and 'Pressure' on the bottom line (see Figure 4-11).
8. Press the ENTER button; the display will then show 'PRESSURE' on the top line and 'psi' or 'kPa' on the bottom line (see Figure 4-11).
9. If necessary, press the up or down buttons to change the units displayed to the required units, then press the ENTER button. Pressures will now be displayed in the units you selected.

Menu	Figure
Switch on	4-2
Switch off	4-3
Normal	4-4
Status	4-5
Control	4-6
Setup	4-7
Inlet purge	4-7
Gas Ballast	4-7
Valve 1	4-7
Run Til Crash	4-8
Setpoints	4-10
Units	4-11
Timeout	4-12
Normal display	4-13
Service	4-14
Serial Numbers	4-15
Zero sensors	4-16
View TIM I/O	4-17
Configuration	4-18
QMB	4-18
Gas Module	4-18
Sensor Module	4-18
Manual	4-19
View Status	4-20
Messages	4-9

Table 4-1 - Menu structure

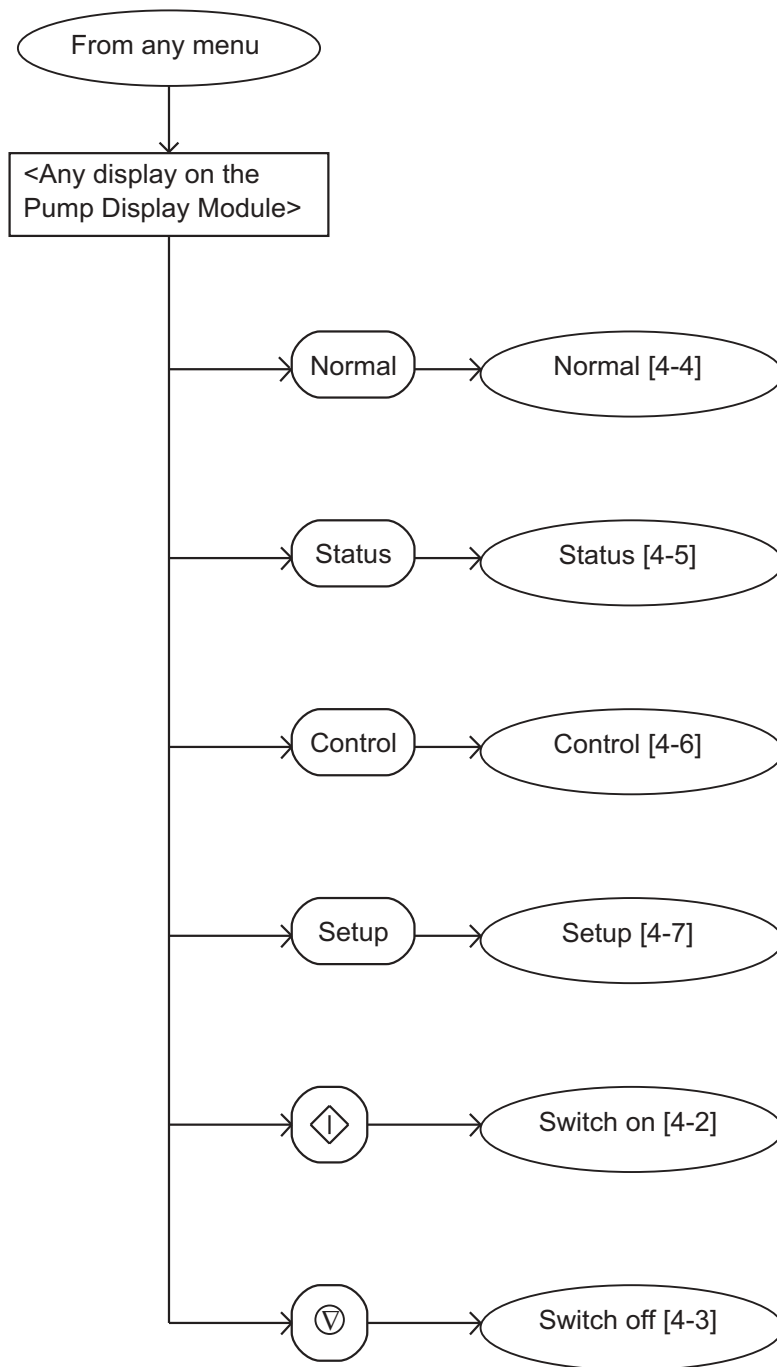

☞ If the Pump Display Module does not have control when you try to switch on or switch off the pumping system, an error message will be displayed: refer to Table 6-4.

Figure 4-1 - Menu logic

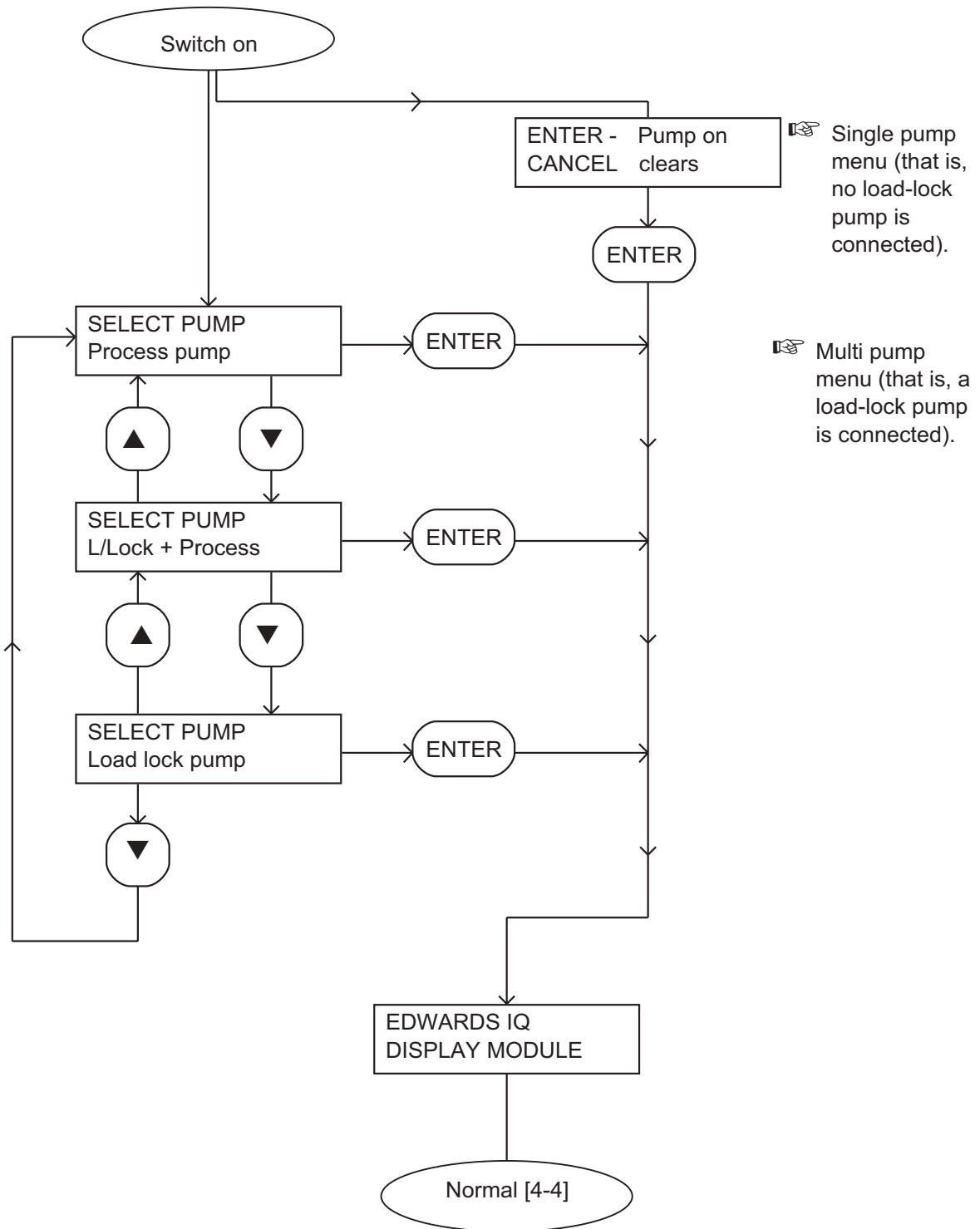

Figure 4-2 - Switch on menu

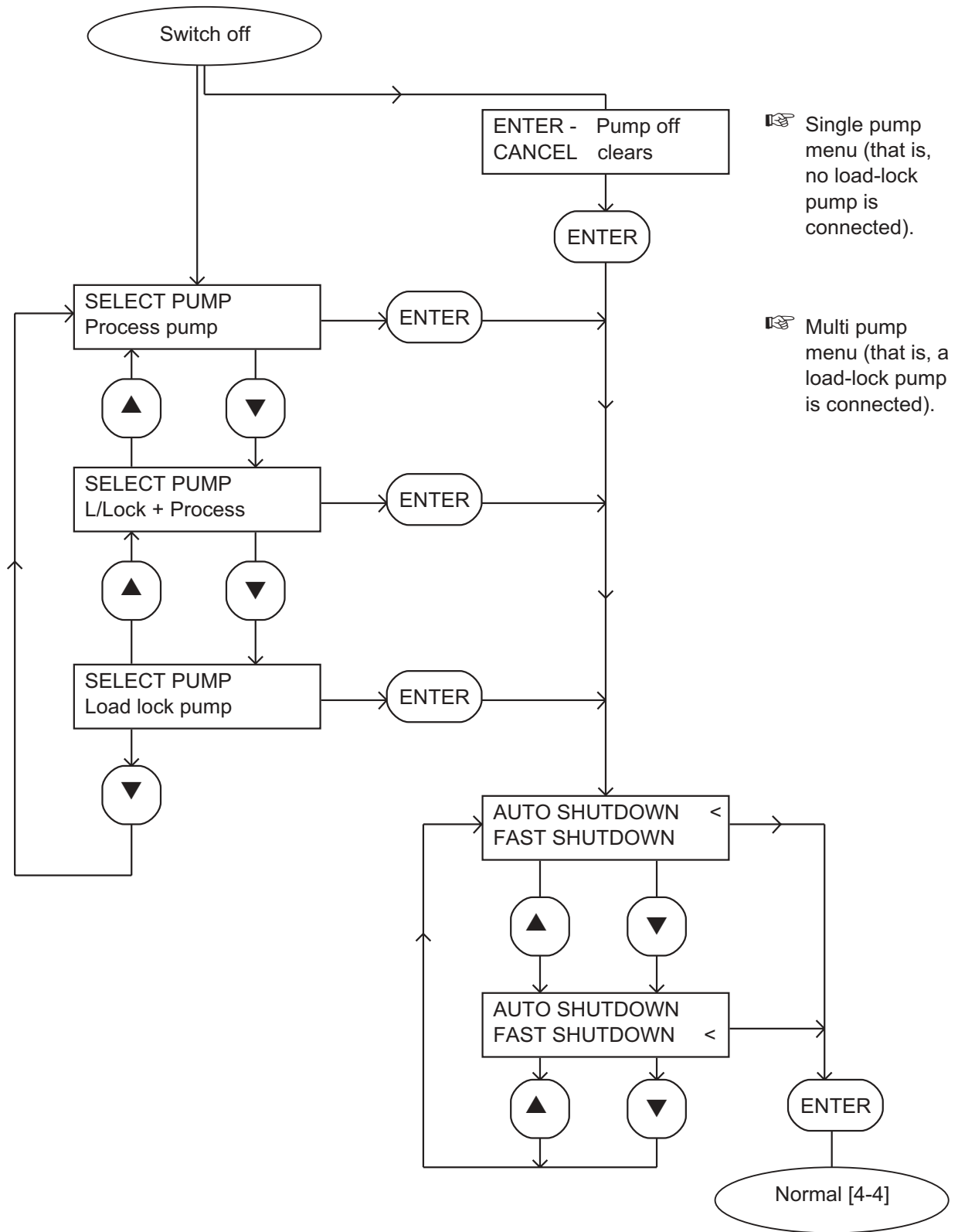

Figure 4-3 - Switch off menu

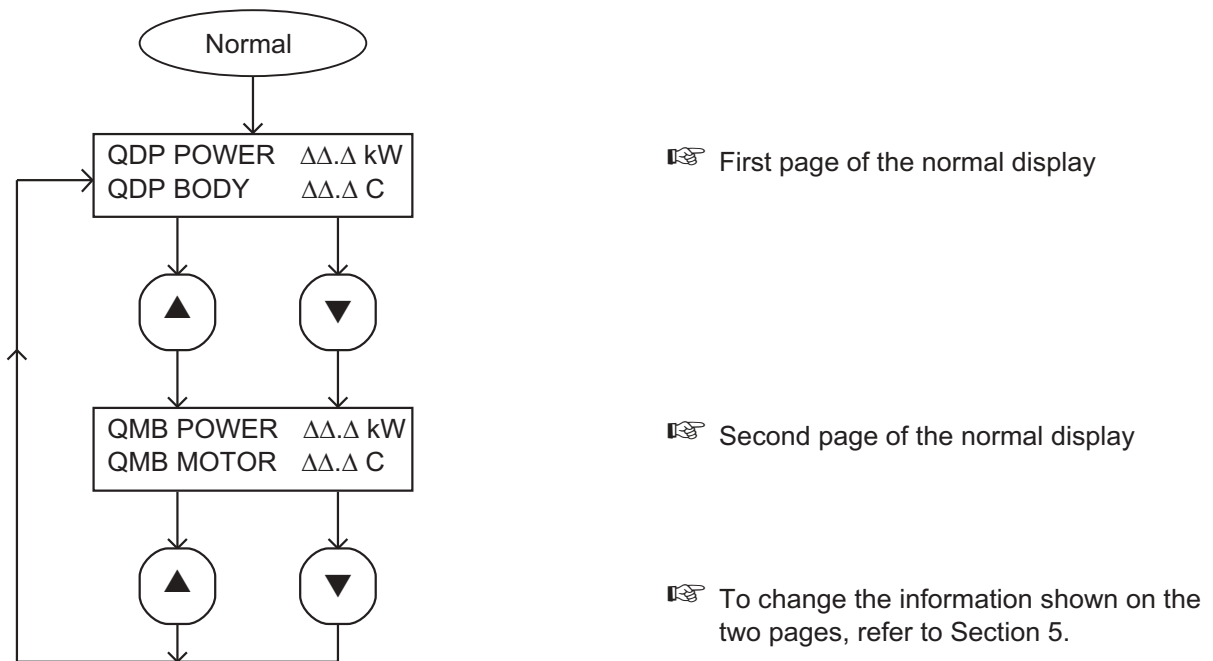

Figure 4-4 - Normal menu

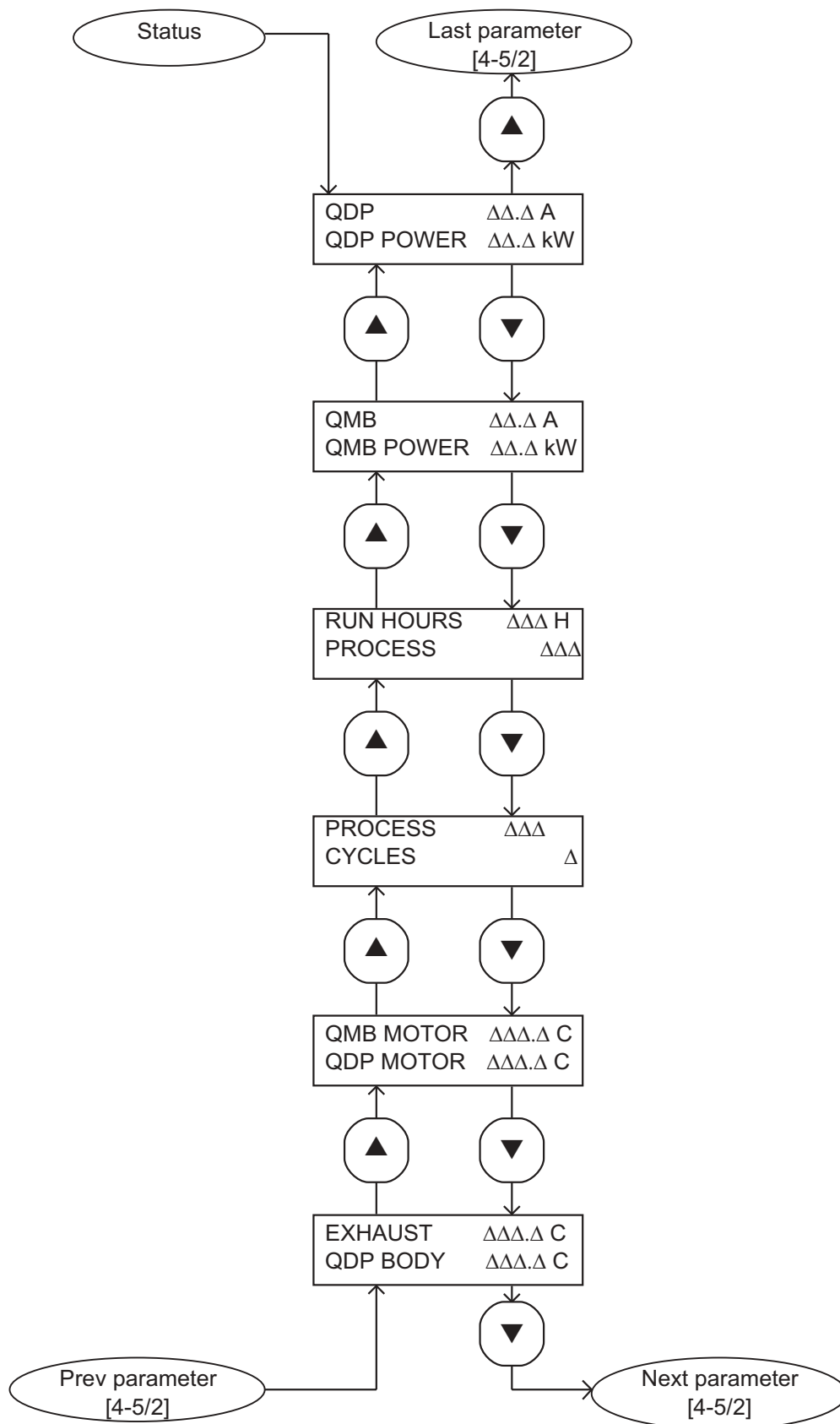

Figure 4-5 - Status menu: sheet 1 of 2

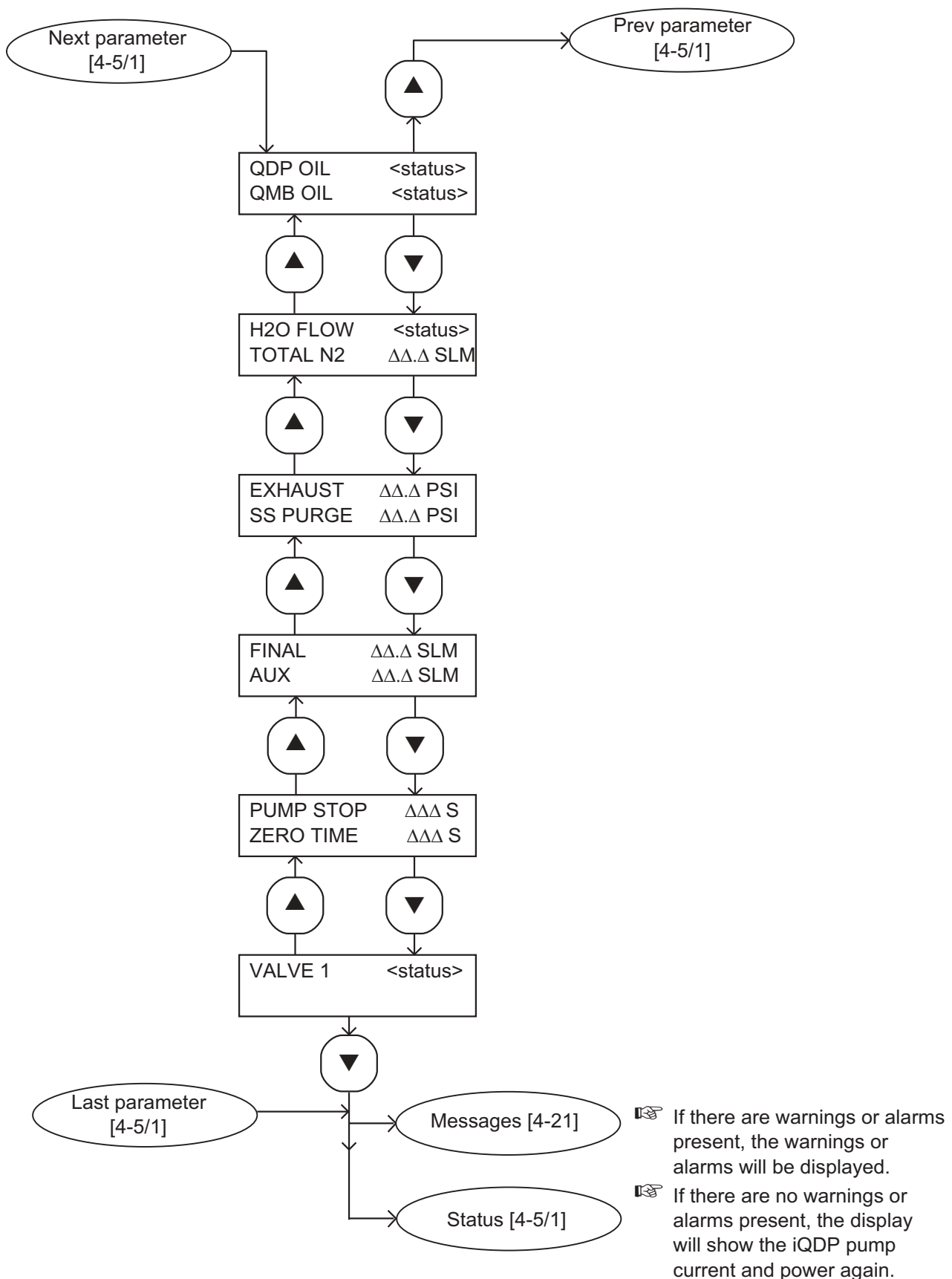

Figure 4-5 - Status menu: sheet 2 of 2

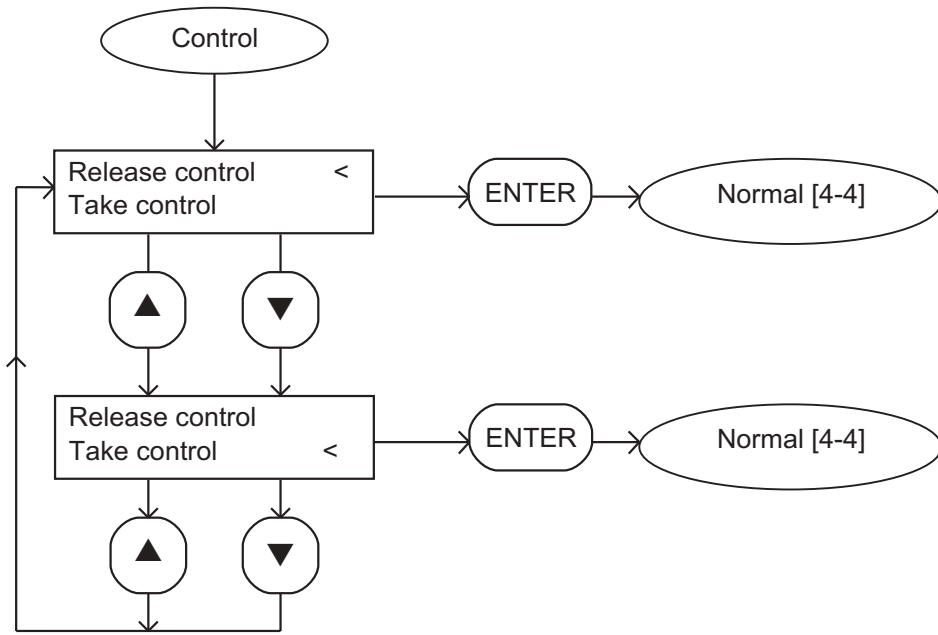
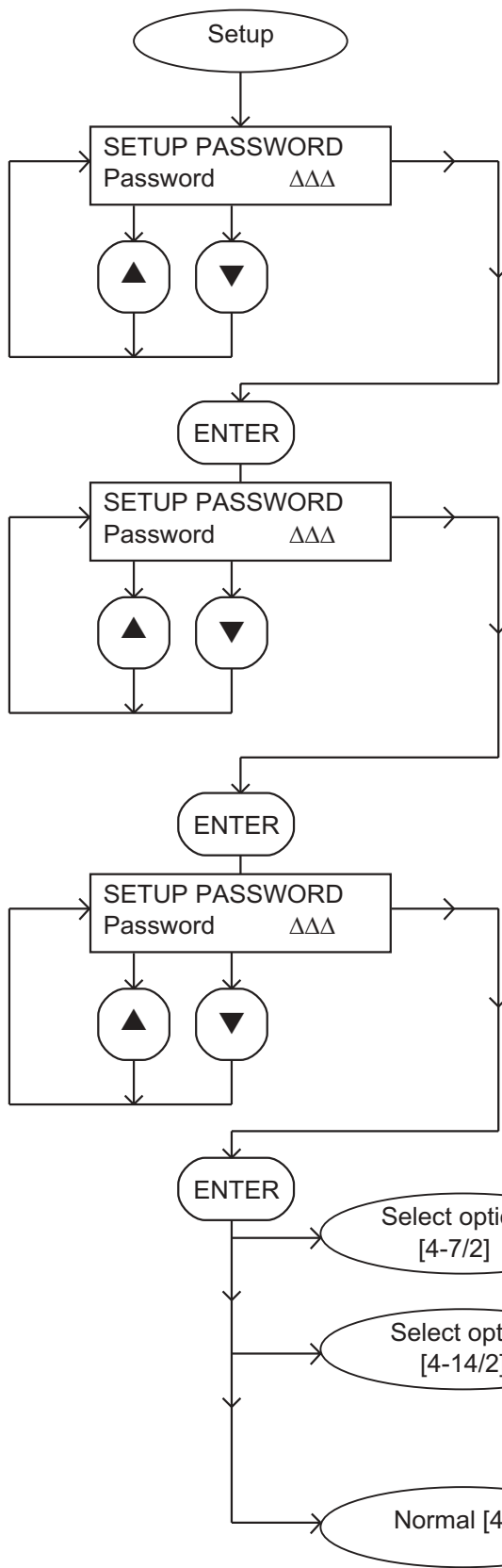

Figure 4-6 - Control menu



Use the up and down buttons to increase or decrease the first digit of the password.

Press ENTER when the digit is set correctly.

Use the up and down buttons to increase or decrease the second digit of the password.

Press ENTER when the digit is set correctly.

Use the up and down buttons to increase or decrease the third digit of the password.

Press ENTER when the digit is set correctly.

If the setup password was entered, continue to select the setup menu option.

If the service password was entered, continue to select the service menu option: the service password is only available to BOC Edwards service engineers.

If the password was incorrect, revert to normal display.

Figure 4-7 - Setup menu: sheet 1 of 3

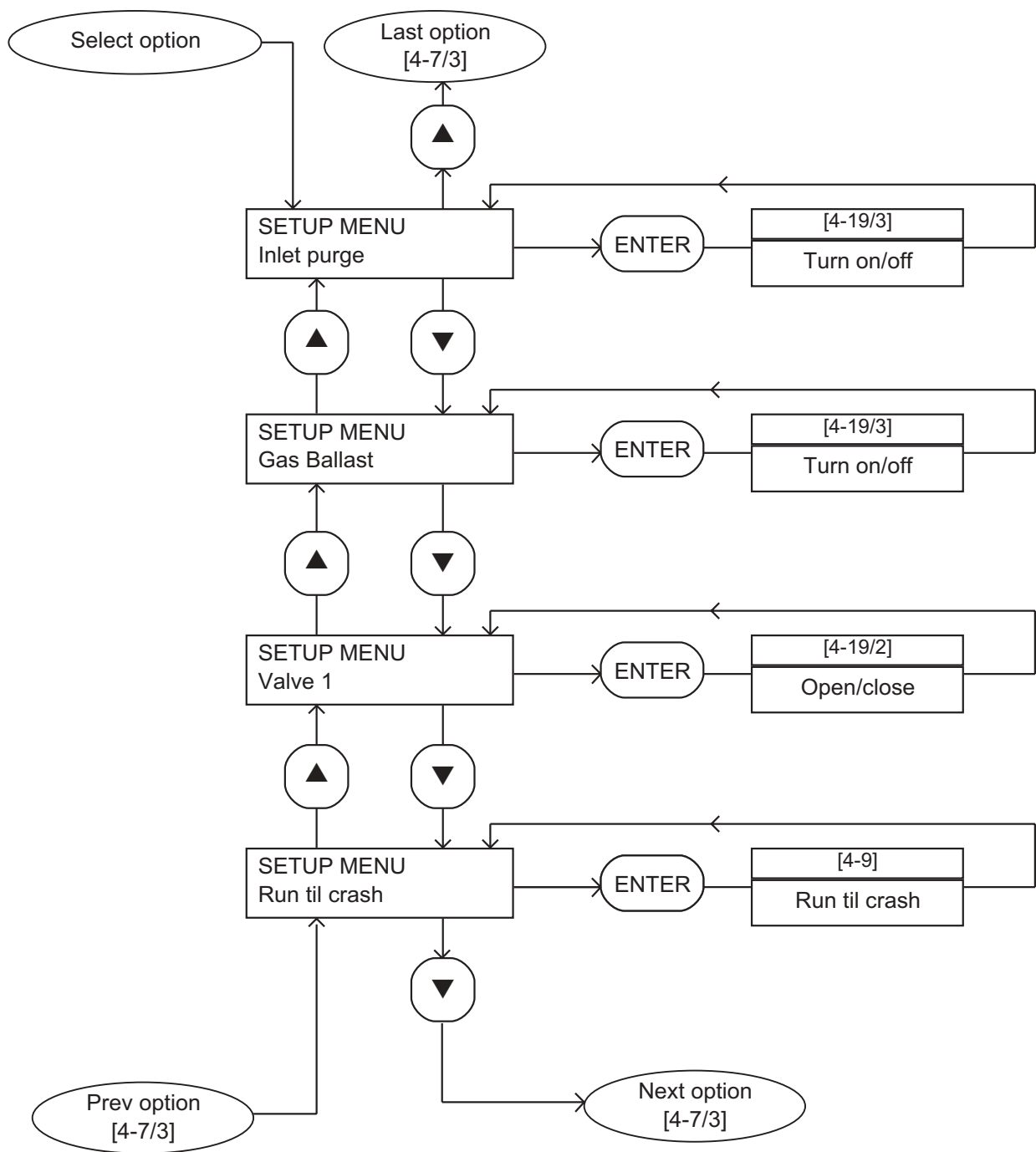

Figure 4-7 - Setup menu: sheet 2 of 3

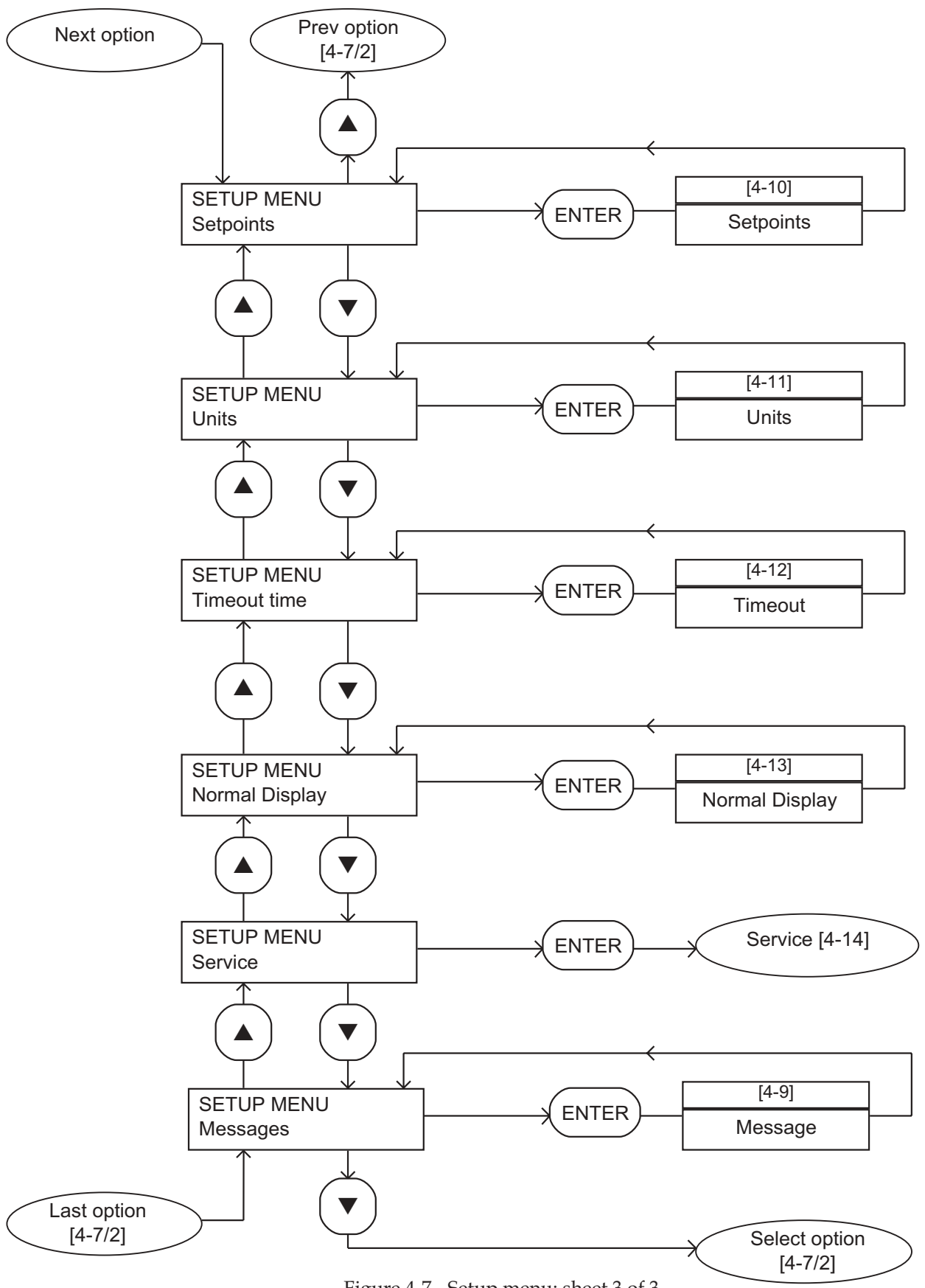

Figure 4-7 - Setup menu: sheet 3 of 3

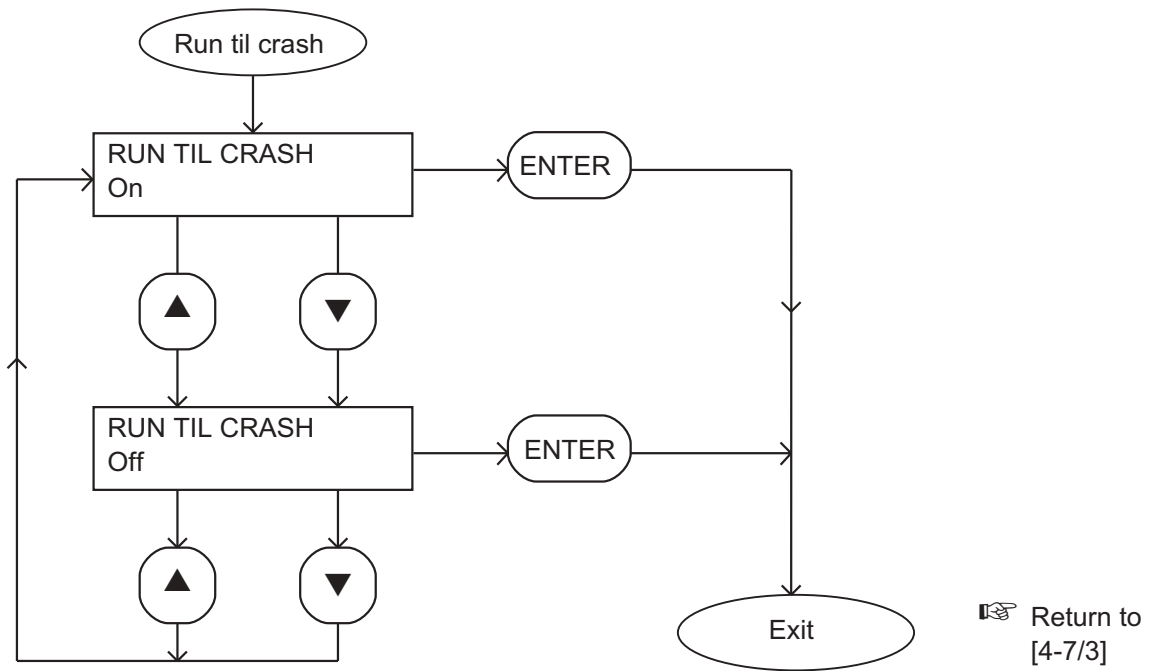

Figure 4-8 - Run til crash menu

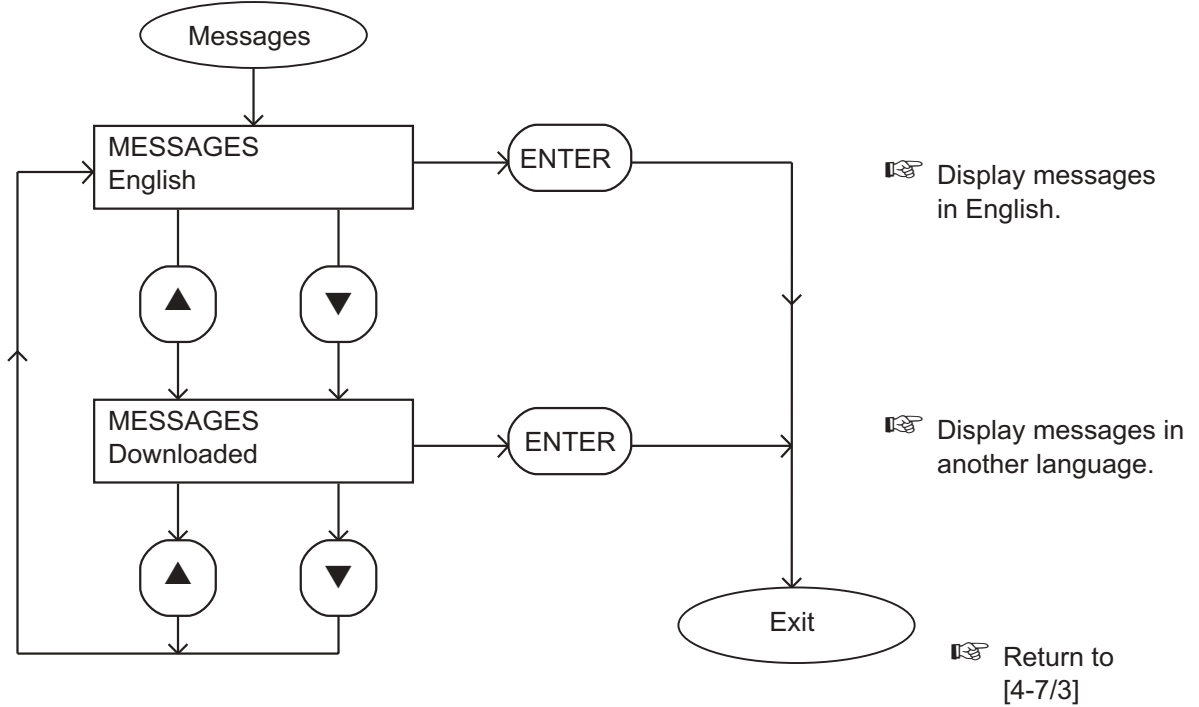

Figure 4-9 - Messages menu

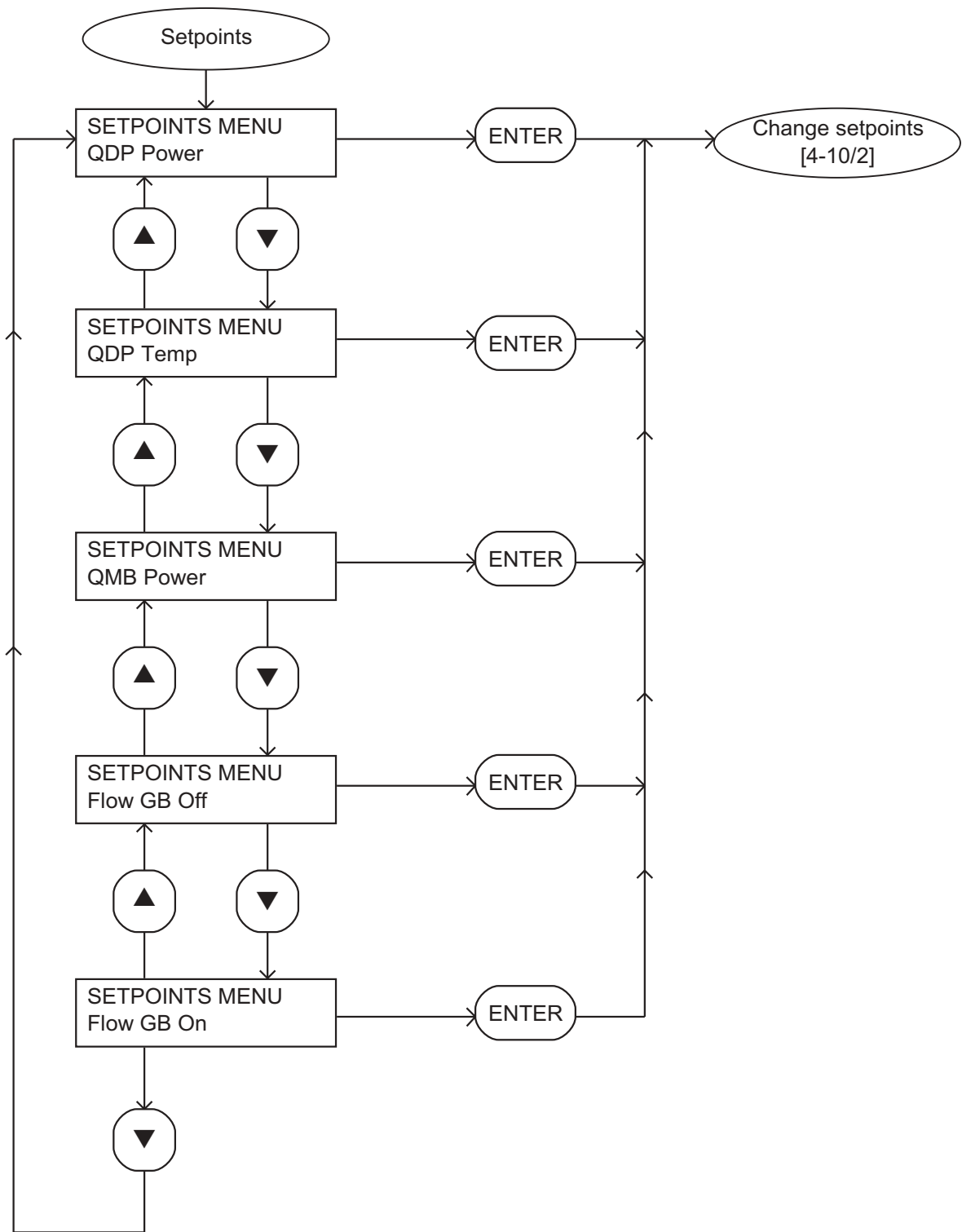

Figure 4-10 - Setpoints menu: sheet 1 of 2

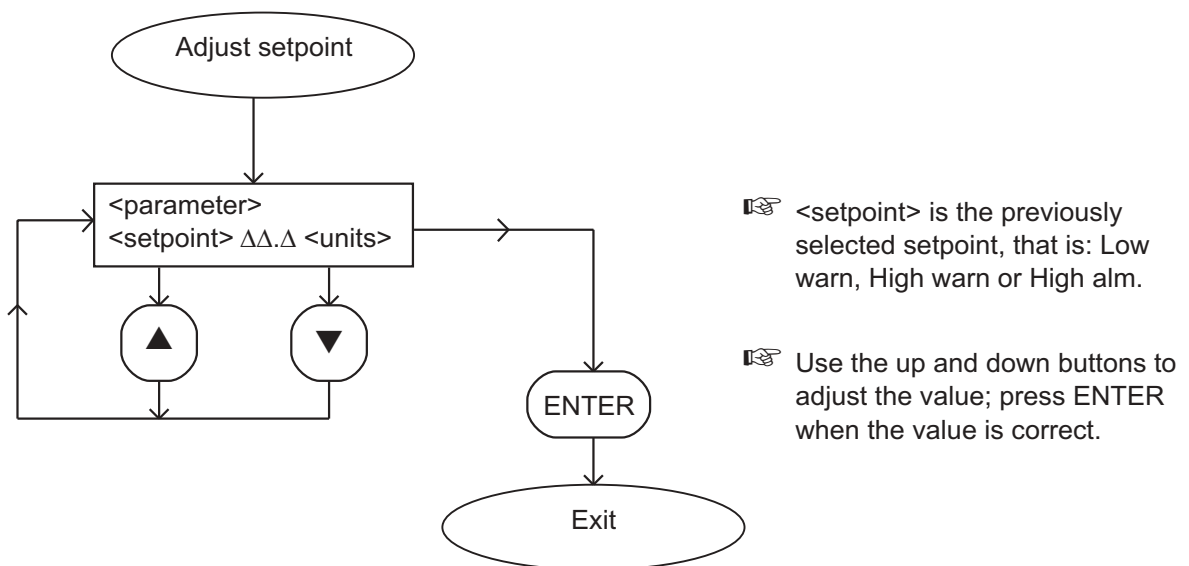
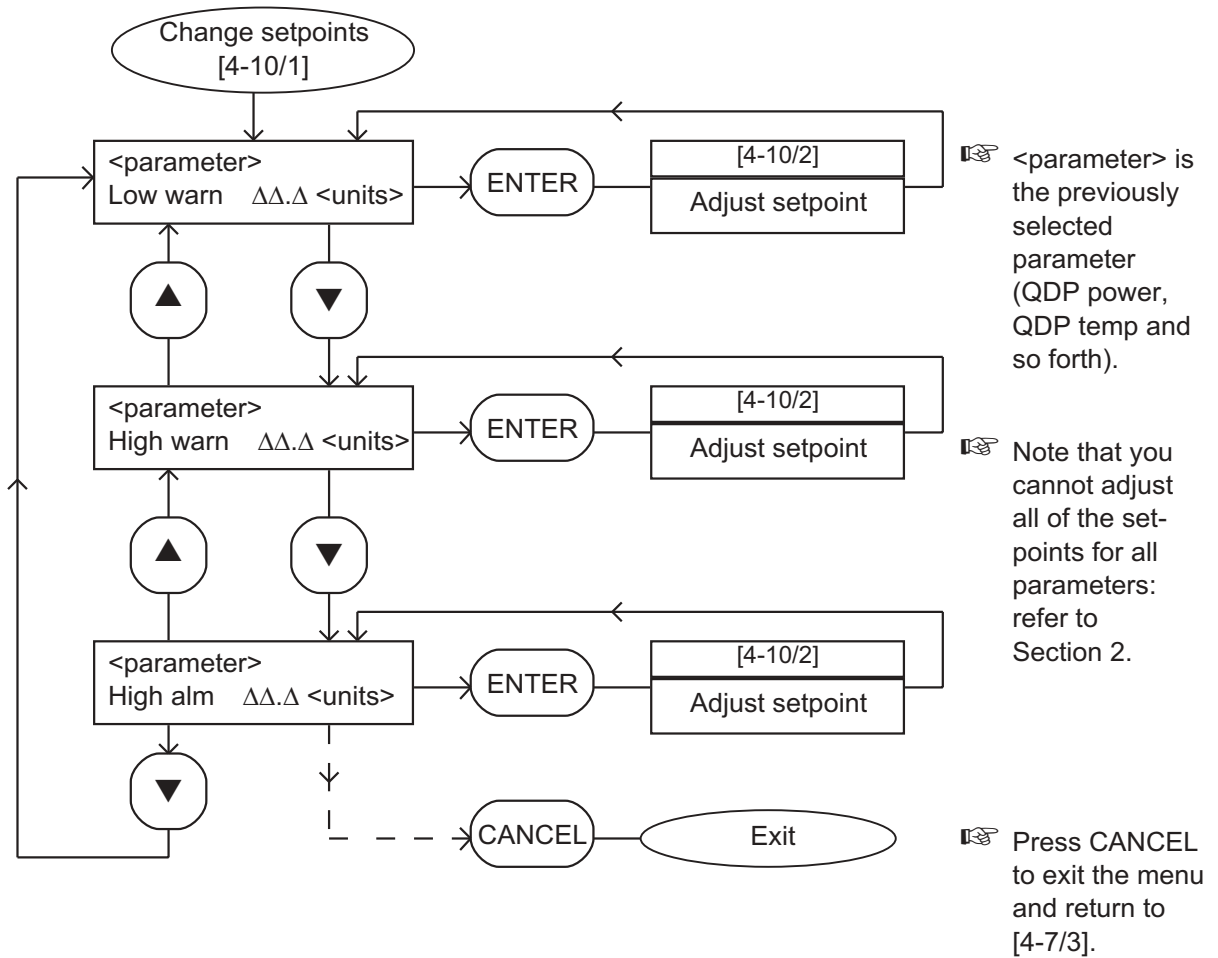

Figure 4-10 - Setpoints menu: sheet 2 of 2

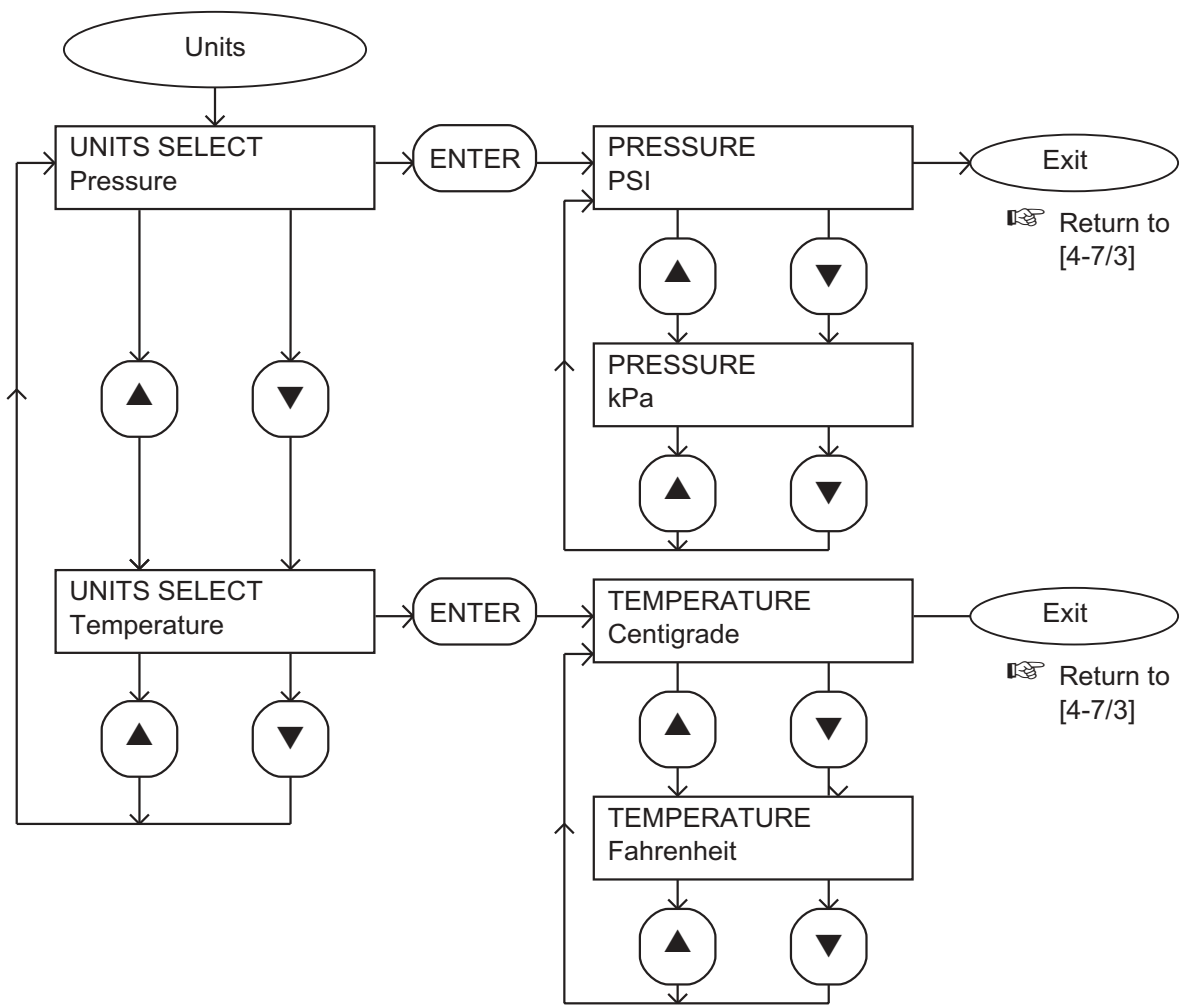

Figure 4-11 - Units menu

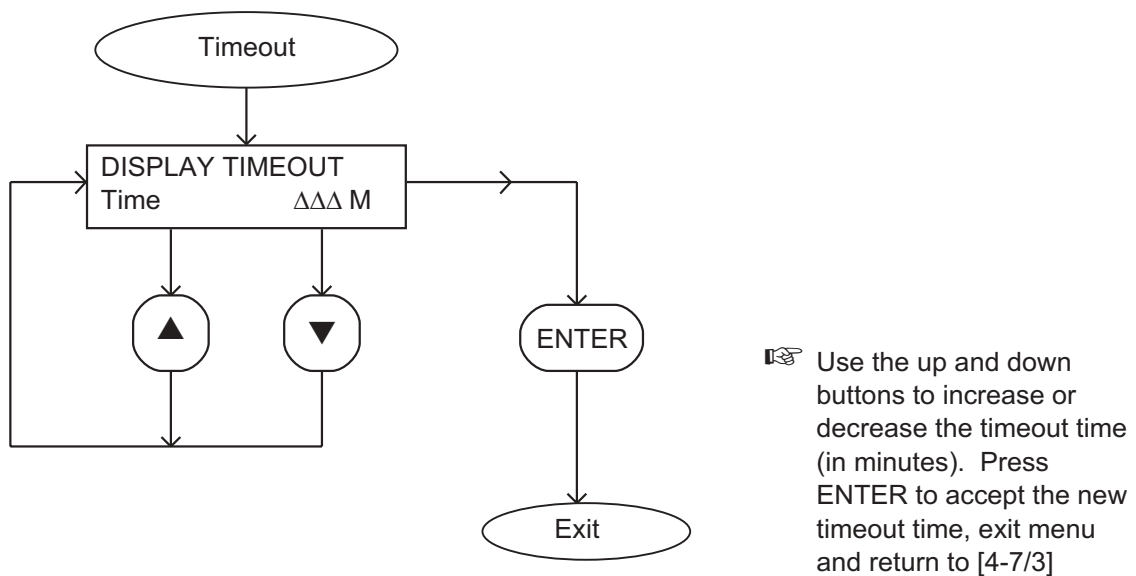

Figure 4-12 - Timeout menu

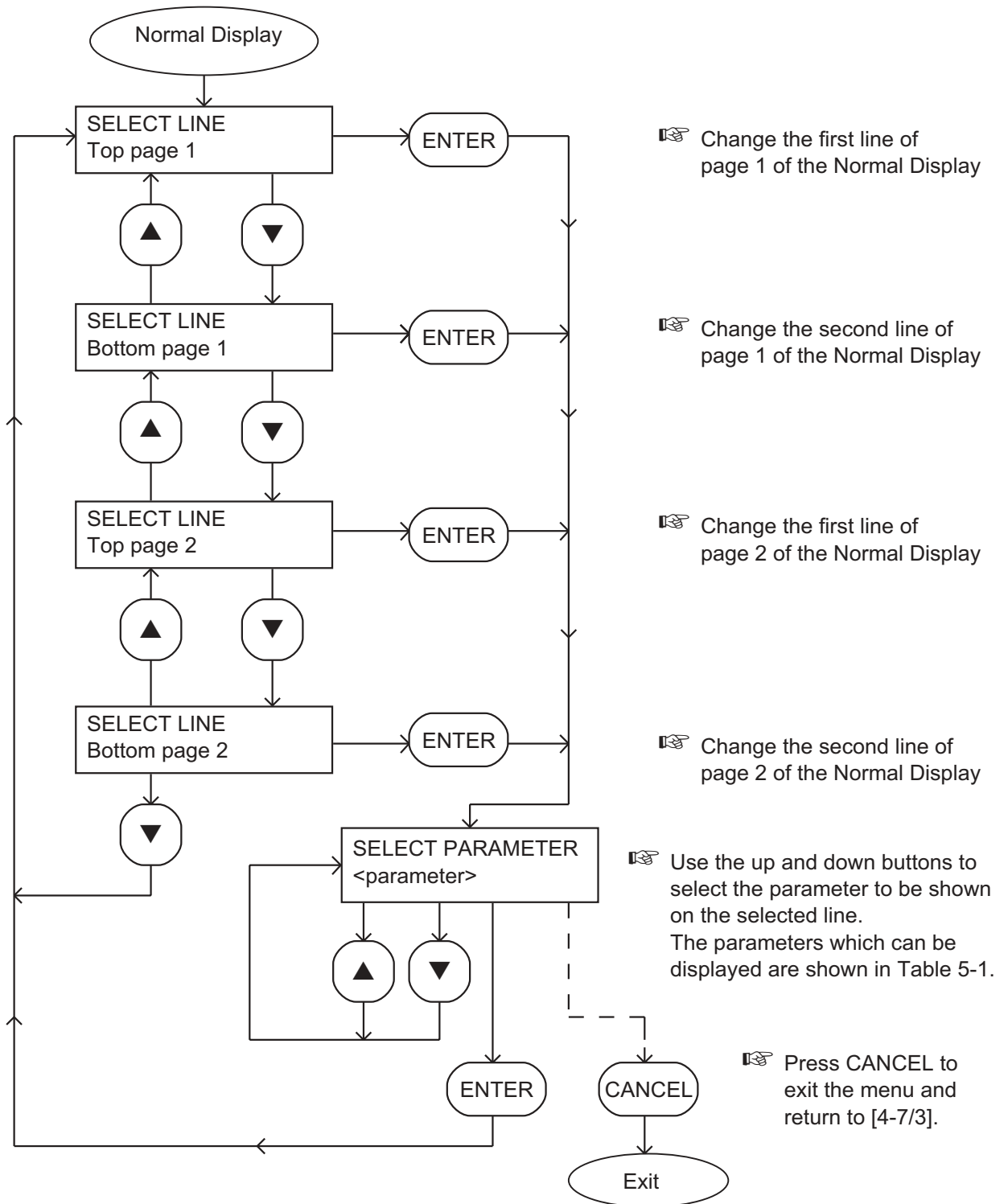

Figure 4-13 - Normal display menu

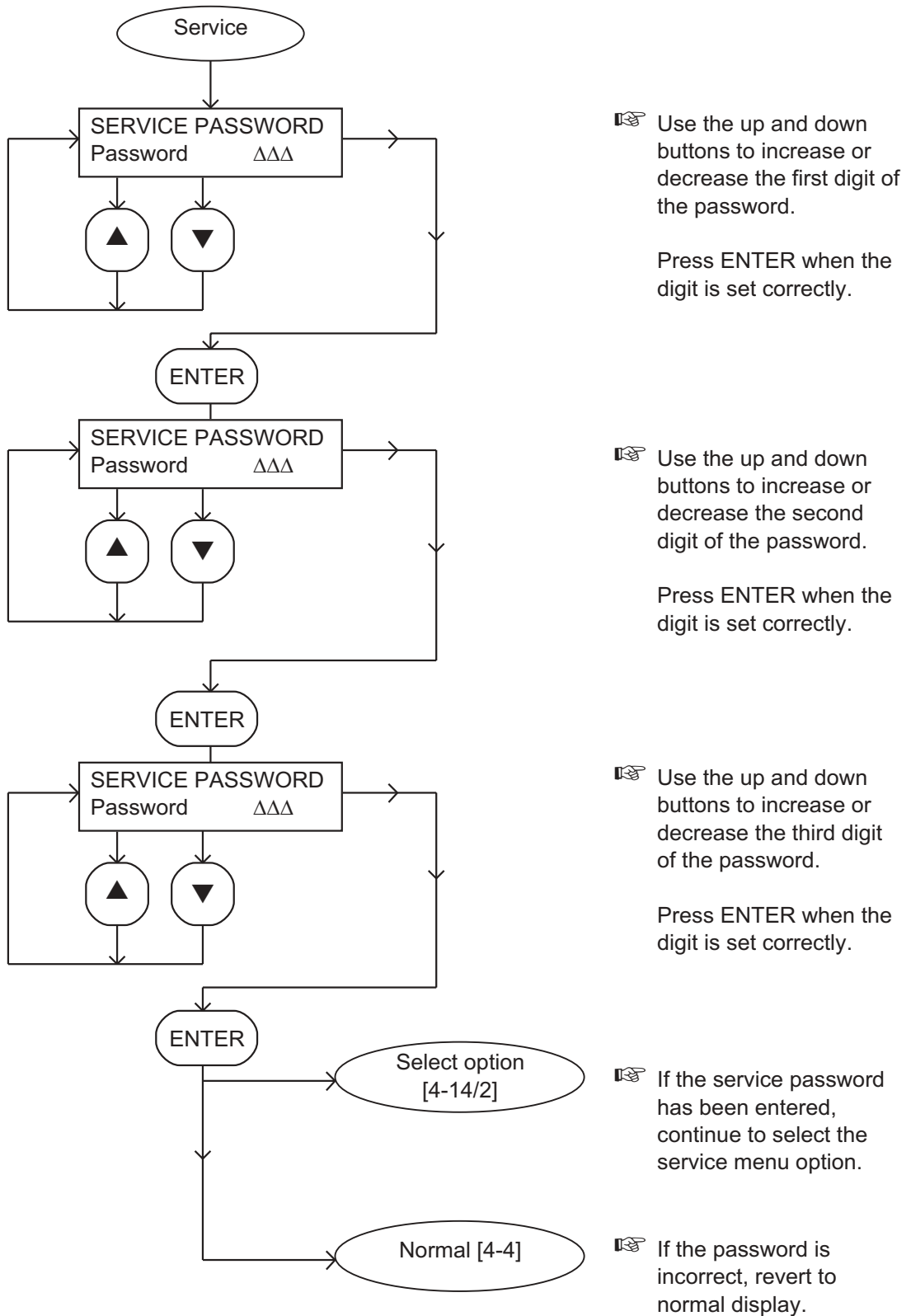

Figure 4-14 - Service menu: sheet 1 of 2

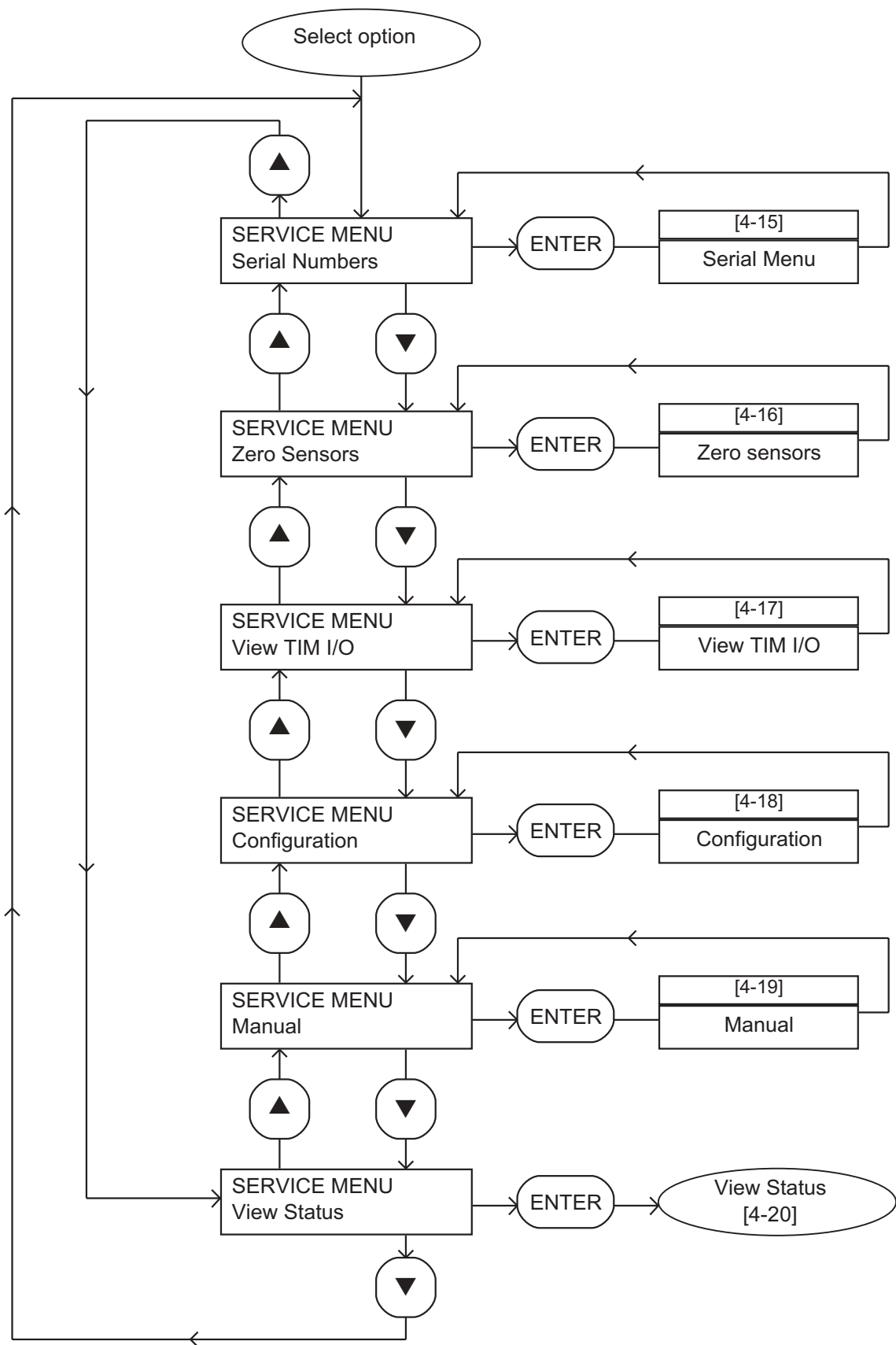

Figure 4-14 - Service menu: sheet 2 of 2

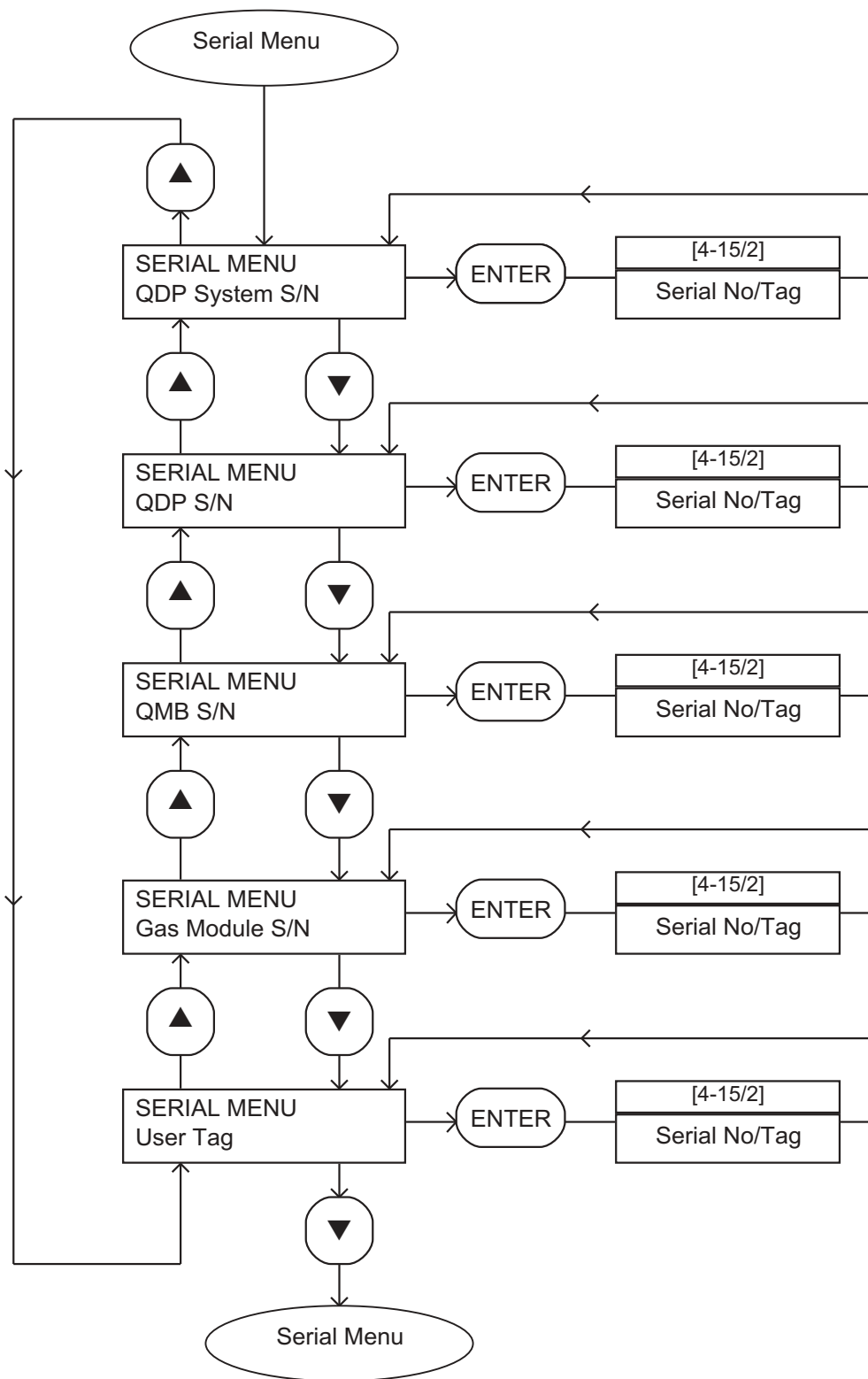
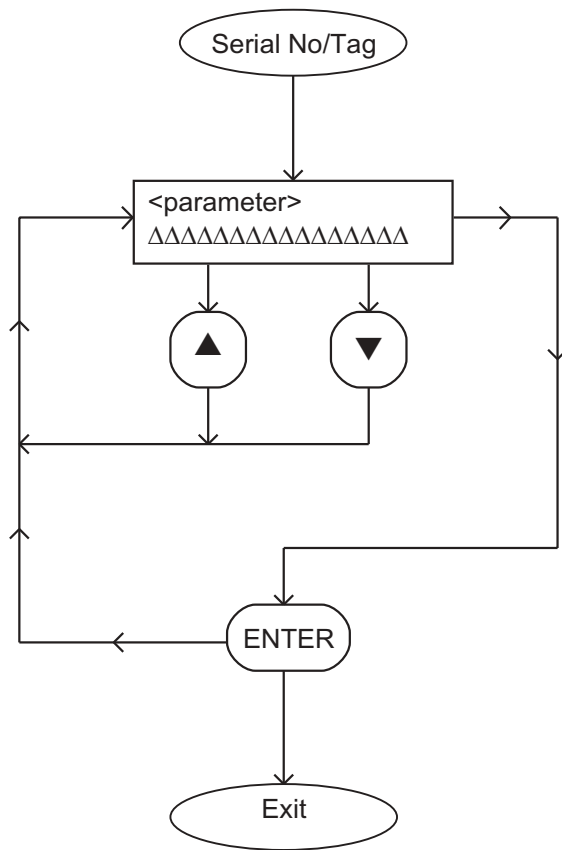

Figure 4-15 - Serial menu: sheet 1 of 2



☞ <parameter> is the previously selected parameter (QDP System S/N, QDP S/N, QMB S/N Gas Module S/N or User Tag).

Use the up and down buttons to adjust each character of the serial number or tag (△△△△△△△△△△△△△△△△), then press ENTER.

☞ When ENTER is pressed after the last digit of the serial number or tag, menu exits and returns to [4-15/1].

Figure 4-15 - Serial menu: sheet 2 of 2

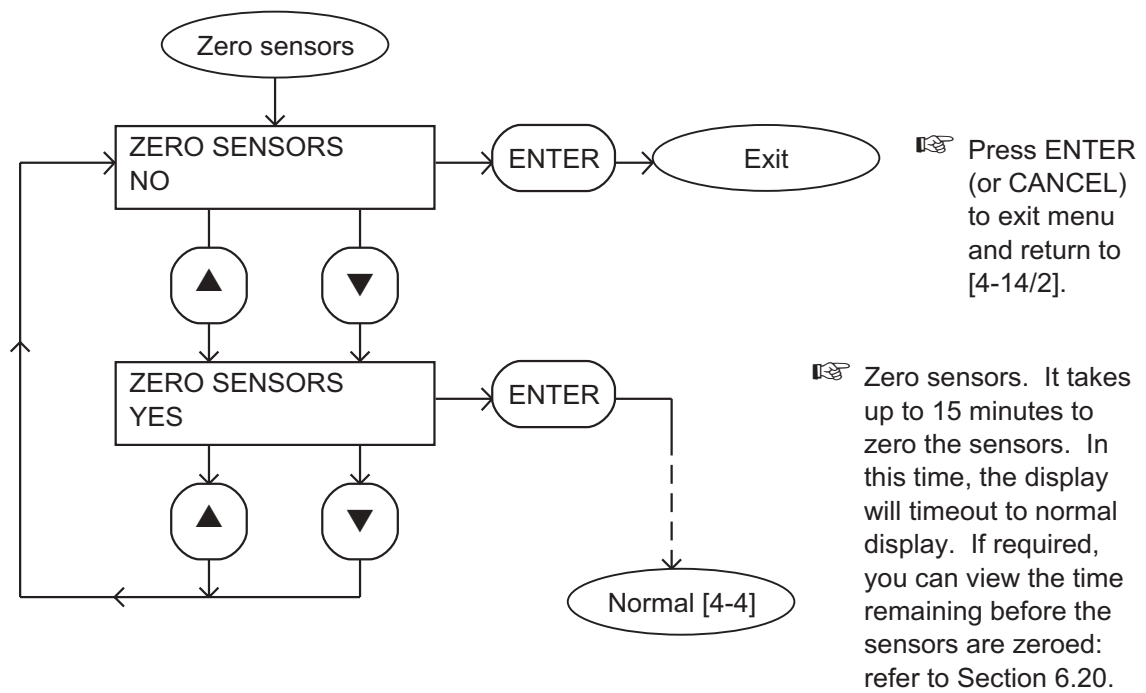

Figure 4-16 - Zero sensors menu

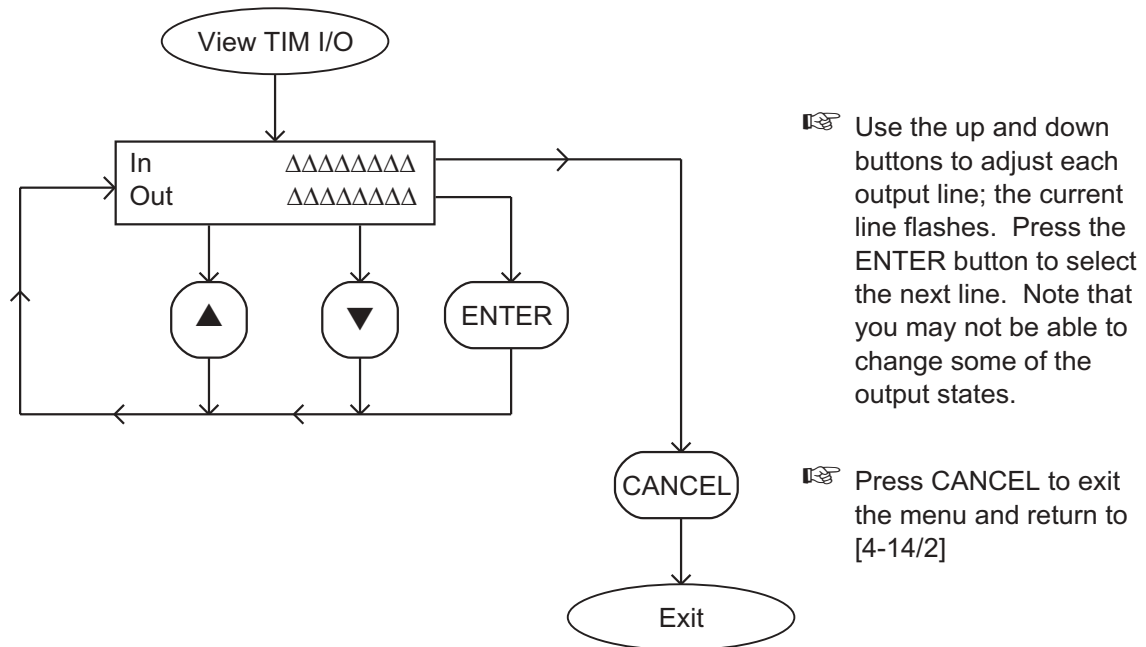

Figure 4-17 - View TIM I/O menu

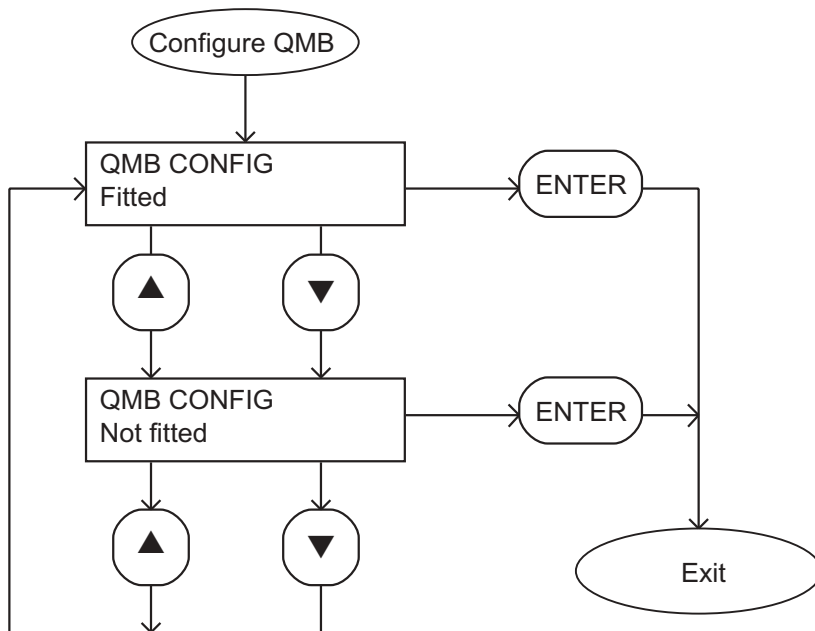
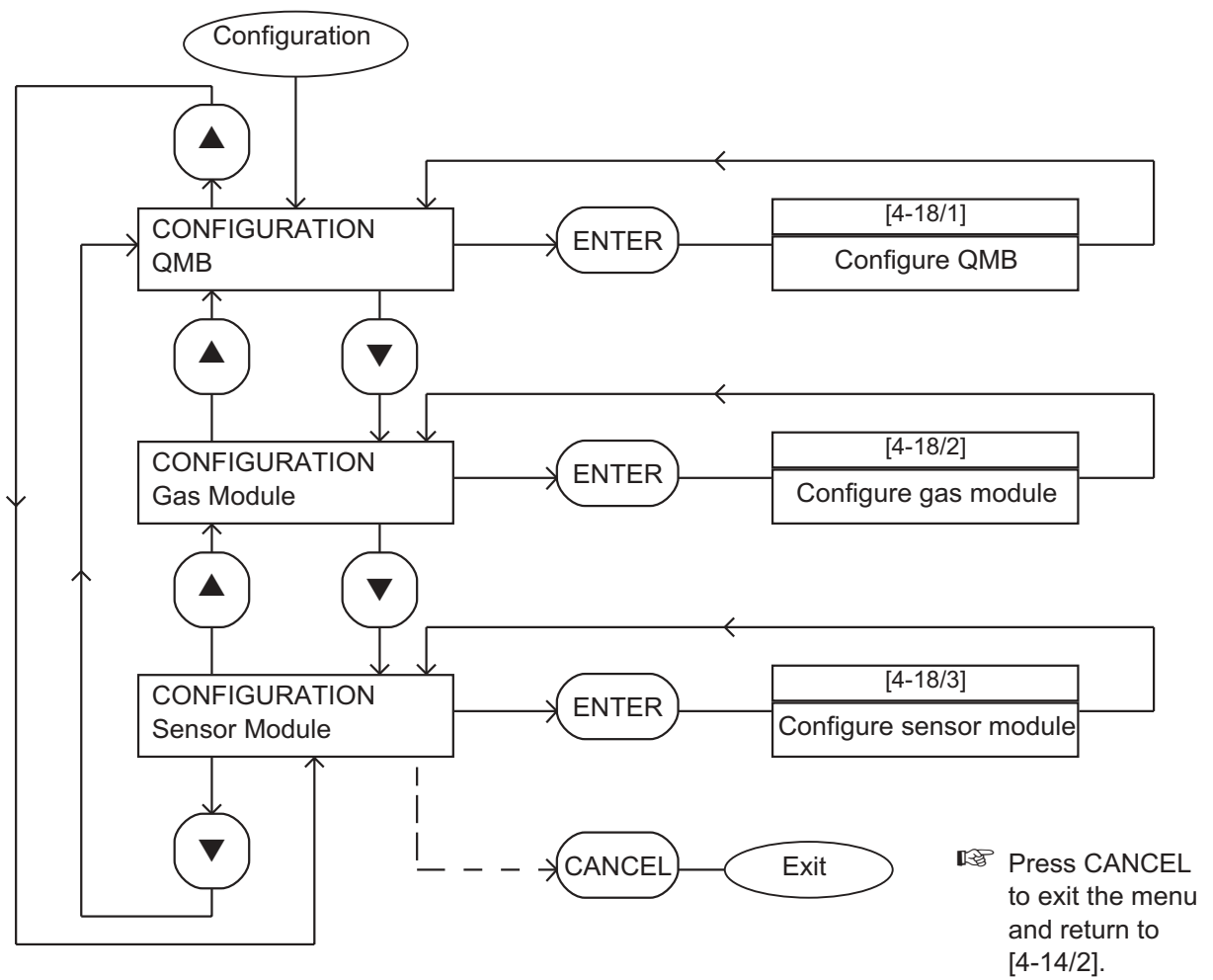

Figure 4-18 - Configure menu: sheet 1 of 3

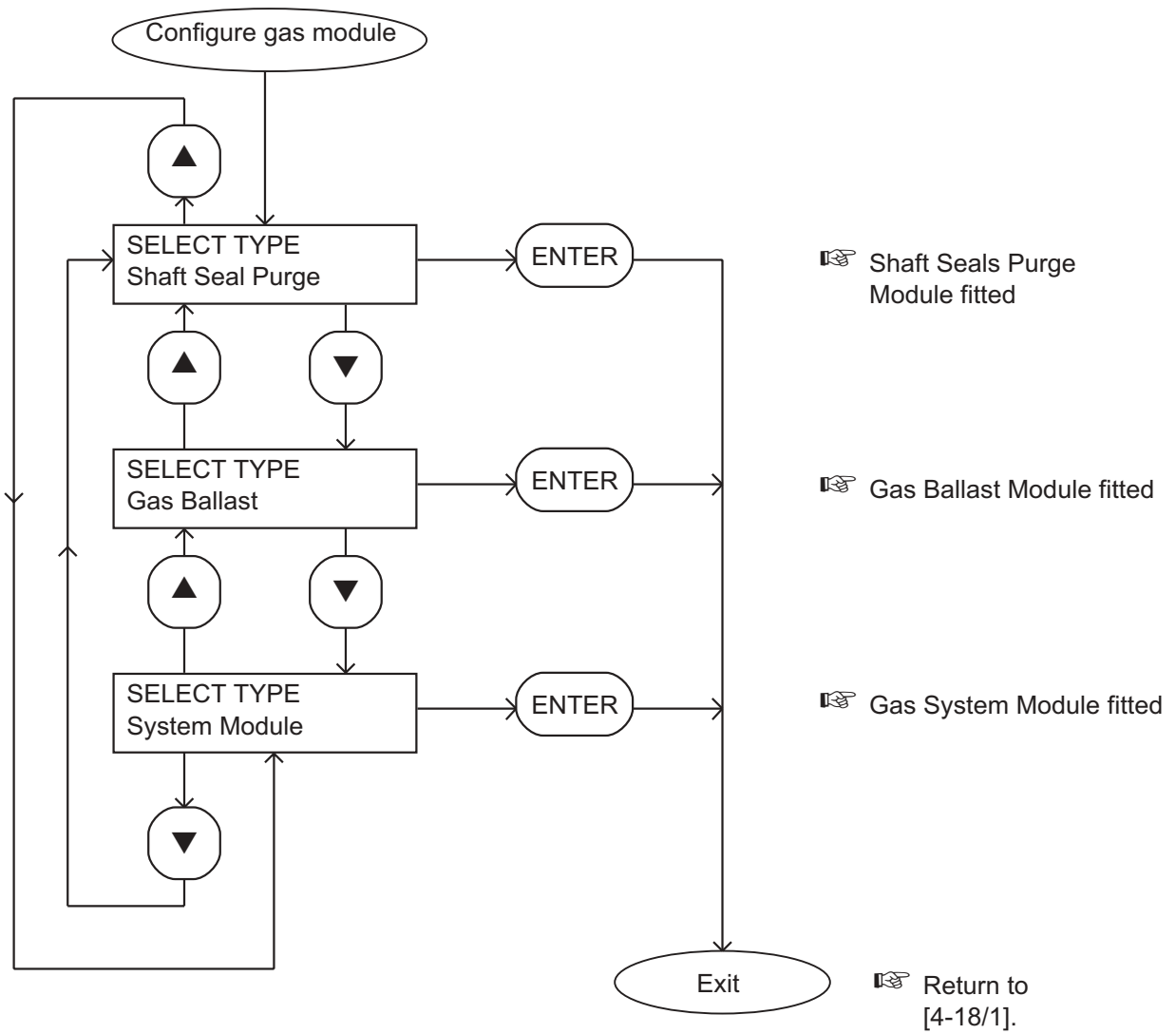

Figure 4-18 - Configure menu: sheet 2 of 3

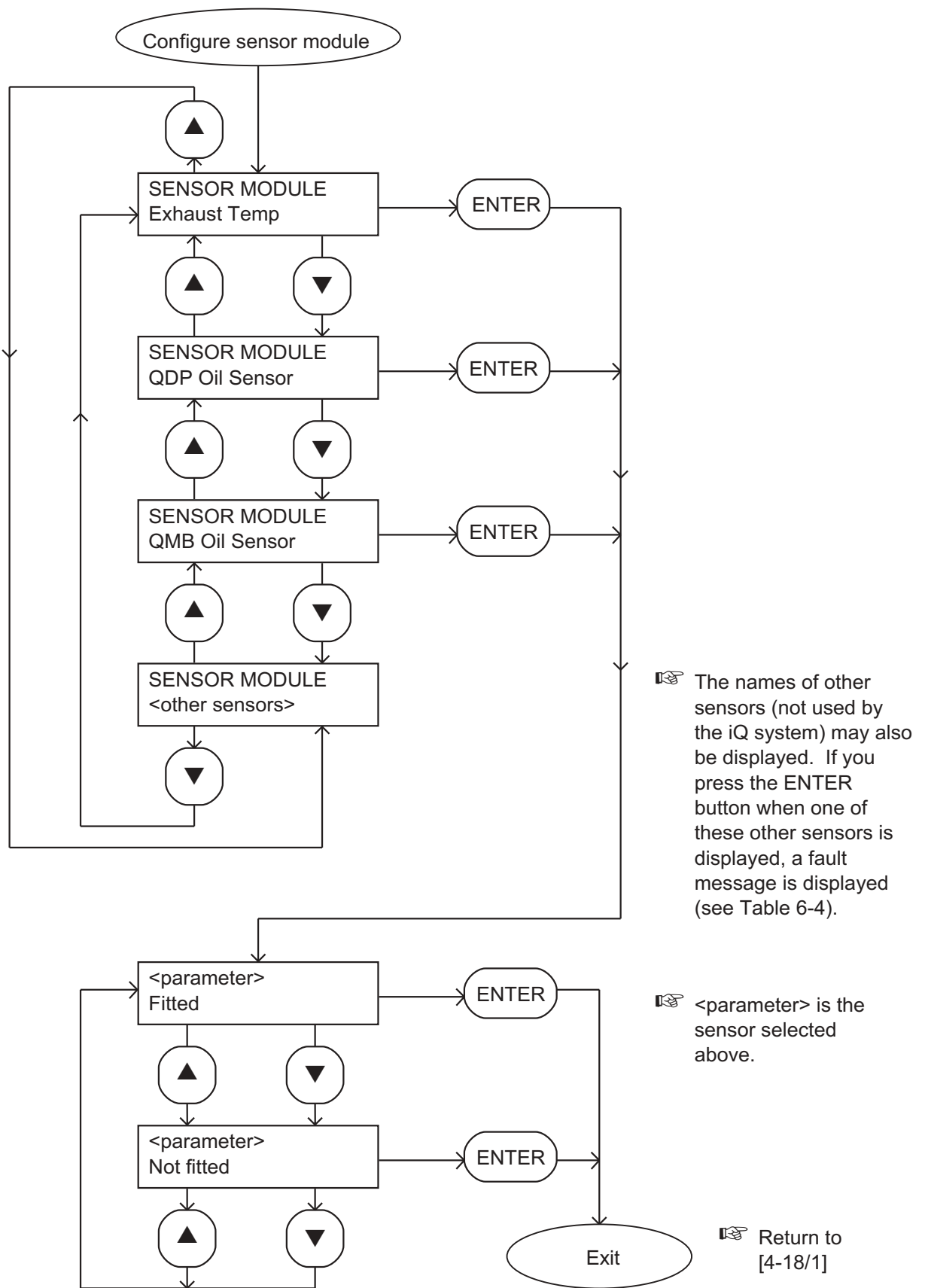

Figure 4-18 - Configure menu: sheet 3 of 3

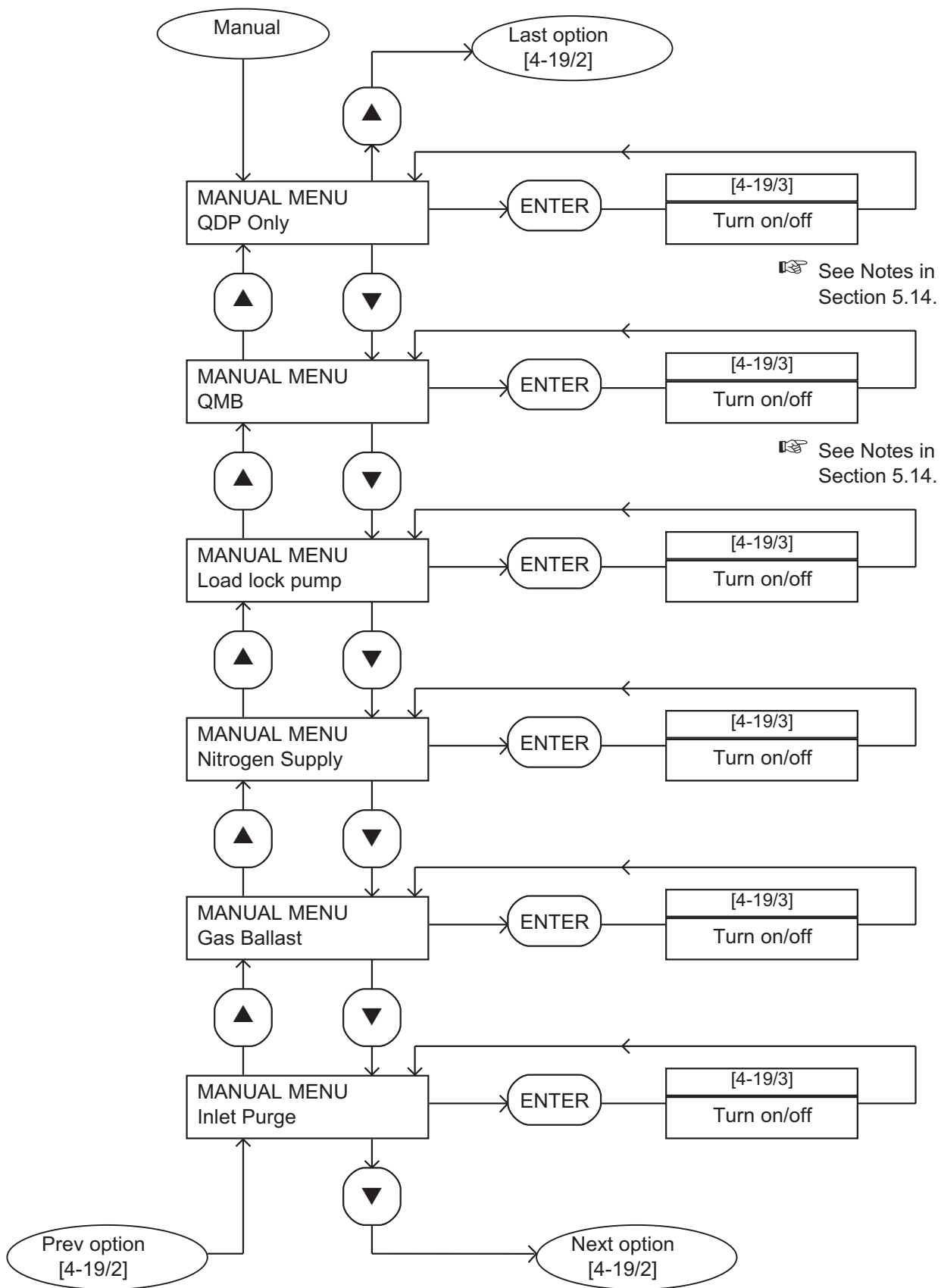

Figure 4-19 - Manual menu: sheet 1 of 3

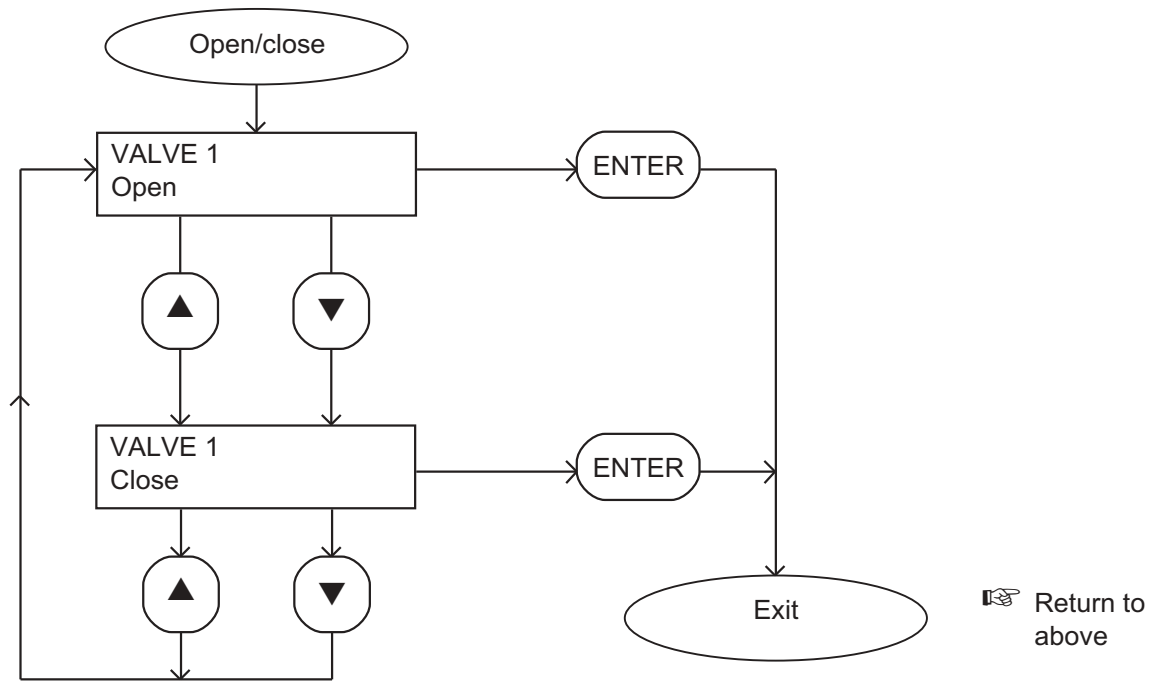
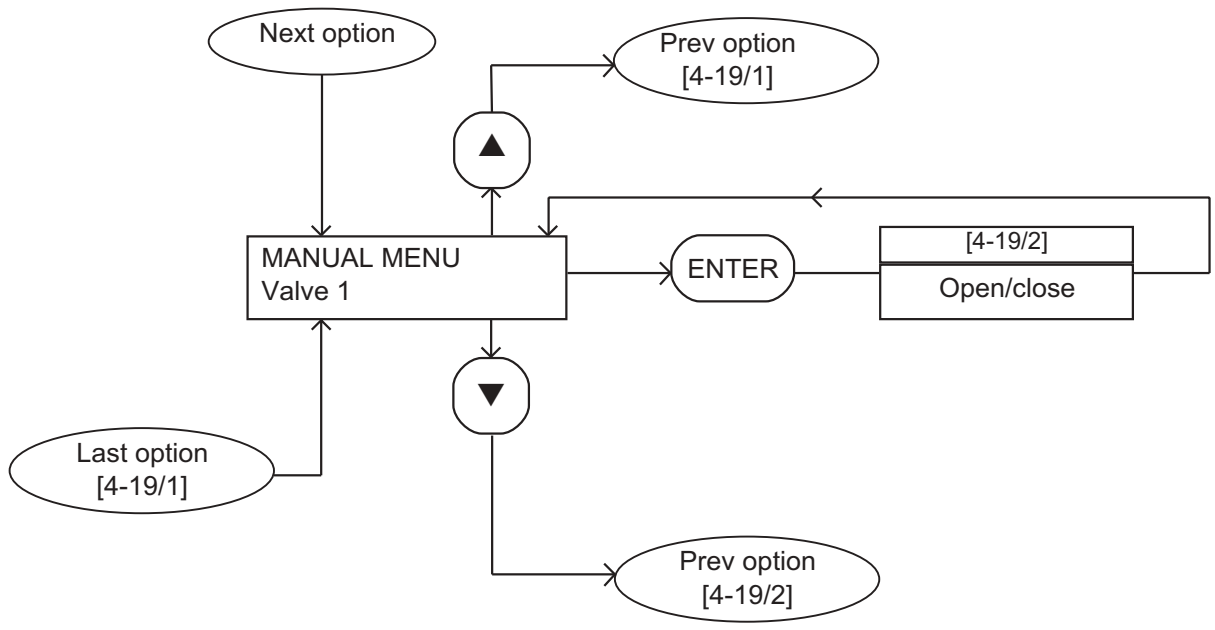

Figure 4-19 - Manual menu: sheet 2 of 3

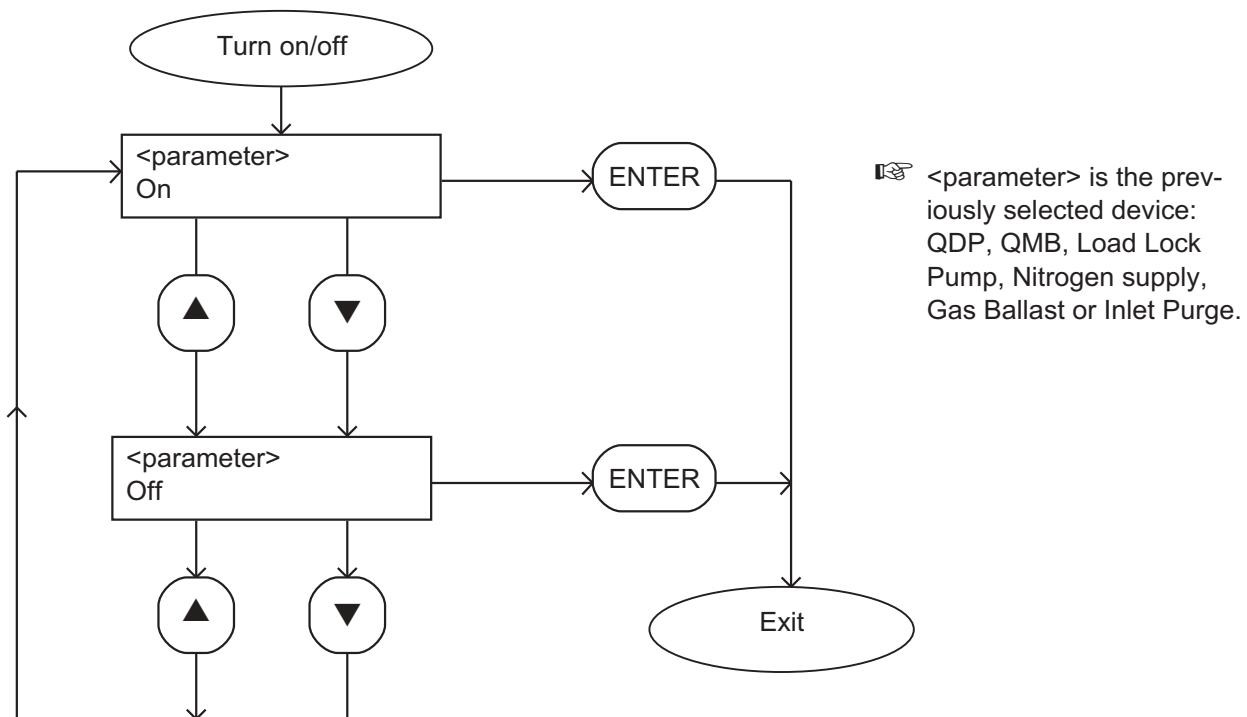

Figure 4-19 - Manual menu: sheet 3 of 3

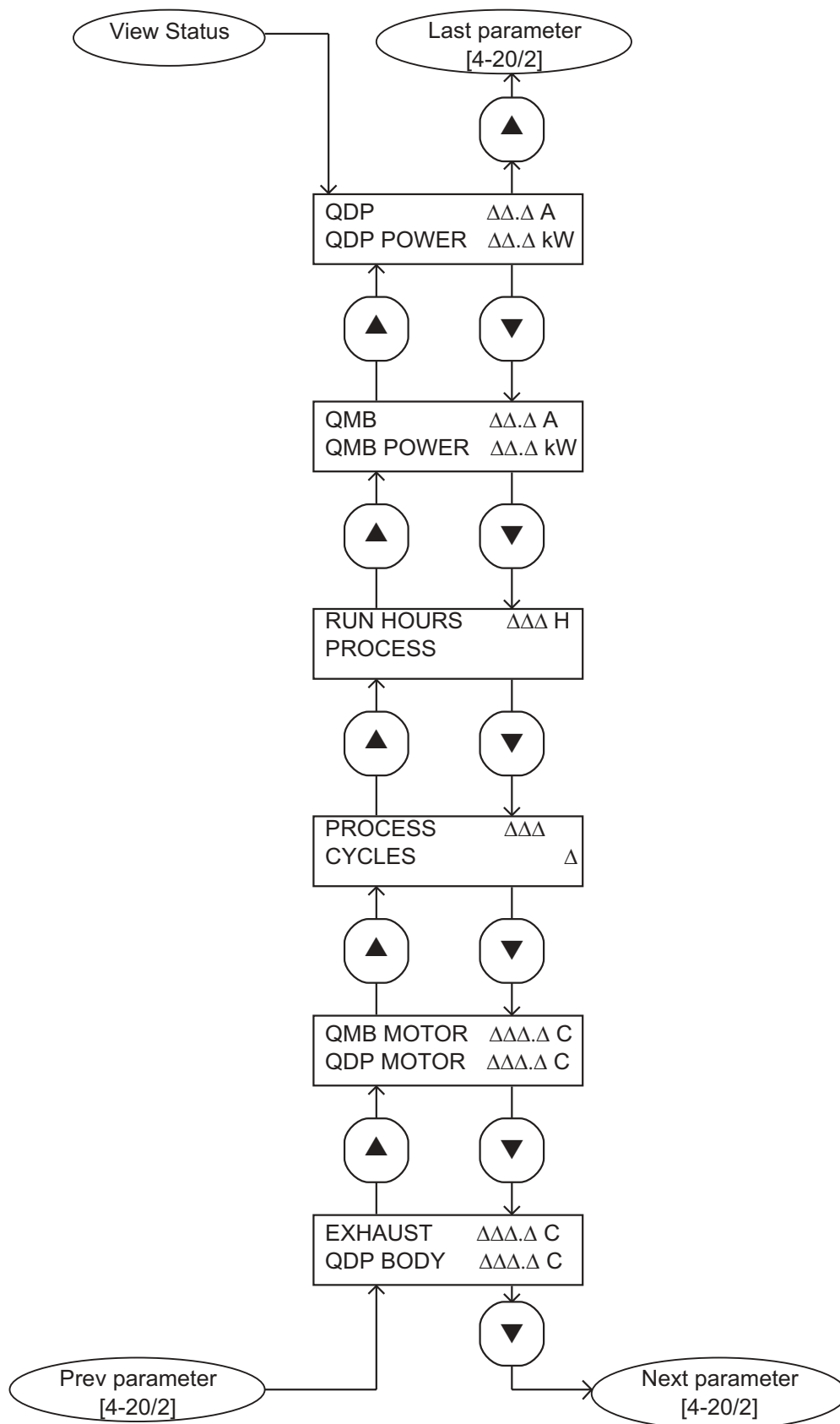

Figure 4-20 - View Status menu: sheet 1 of 2

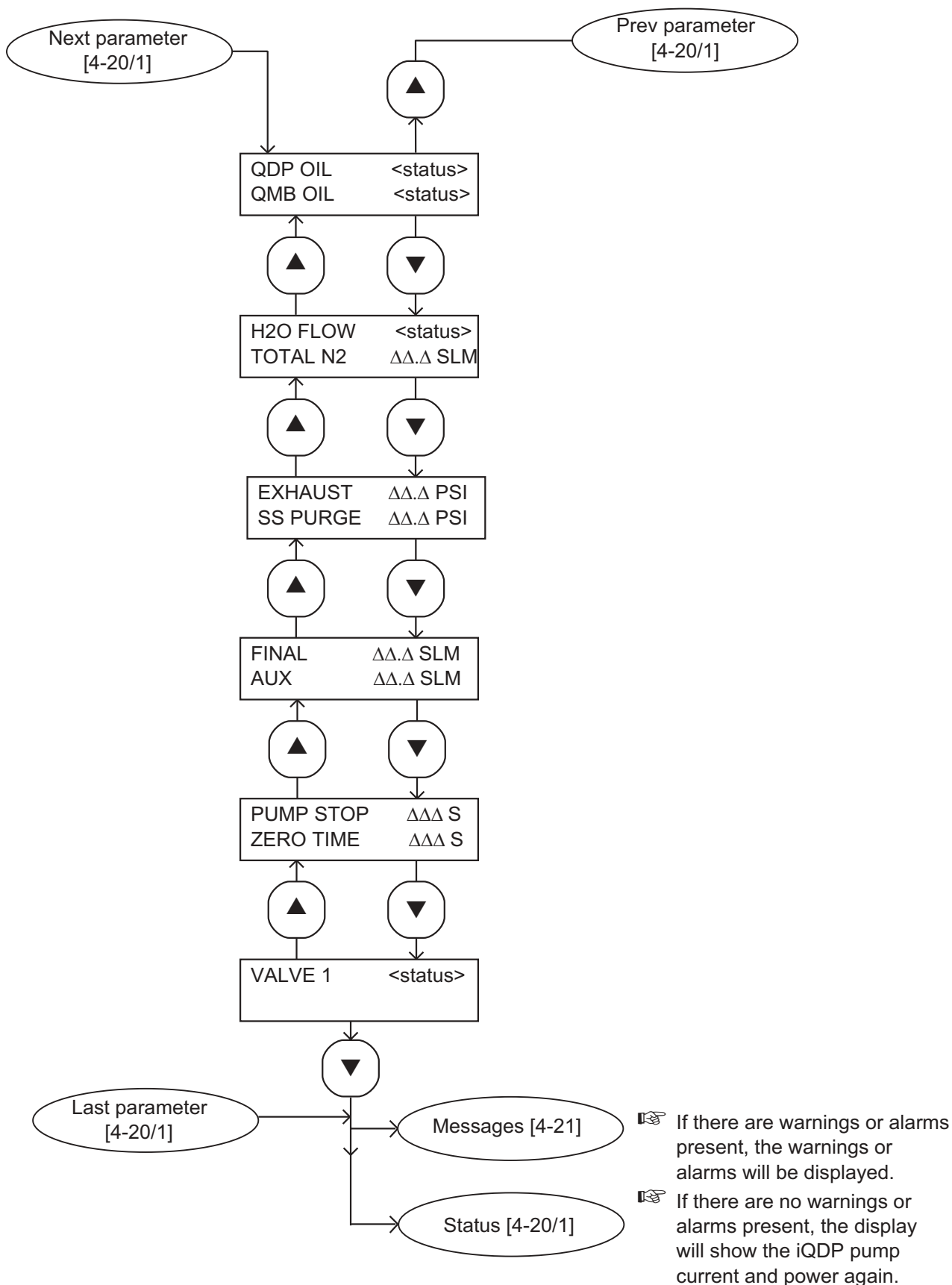

Figure 4-20 - View Status menu: sheet 2 of 2

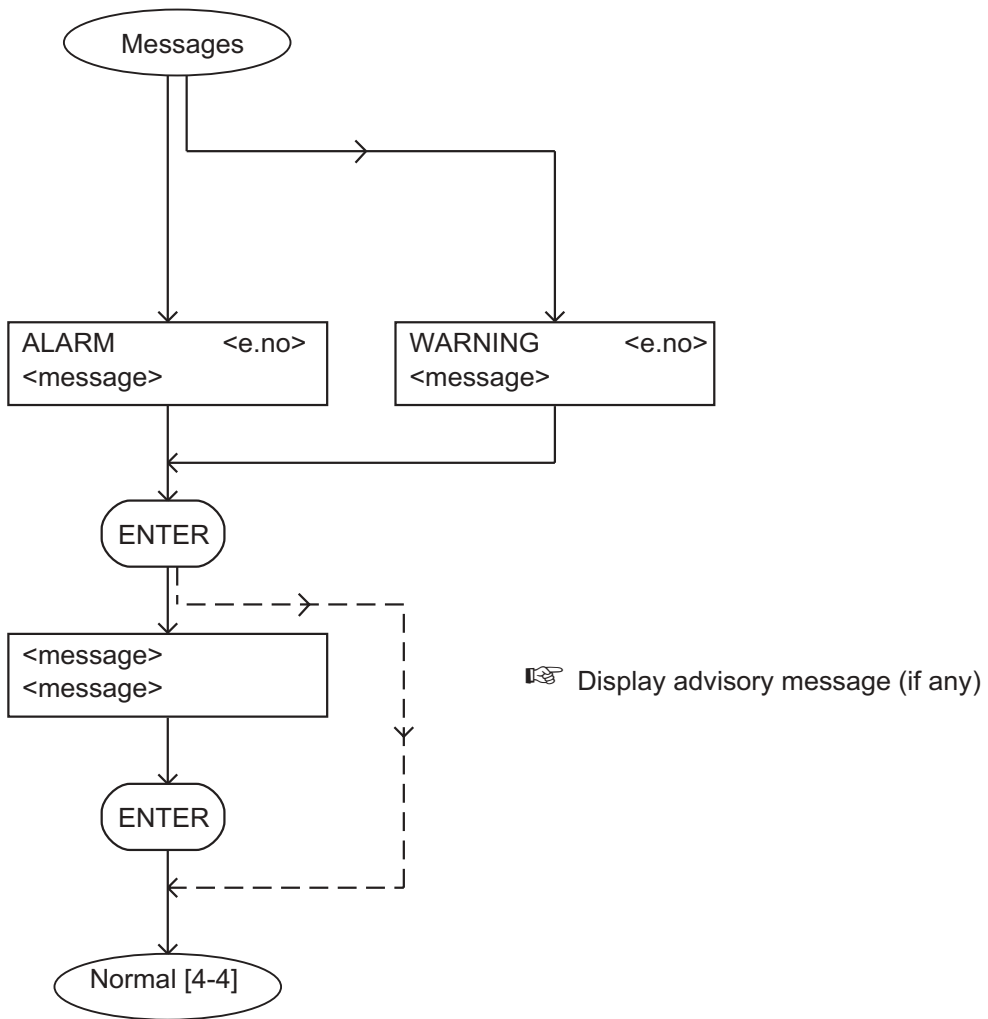

Figure 4-21 - Warning and alarm messages menu

5 OPERATION

5.1 ATEX directive implications

Note: The information in this section only applies to an iQ system fitted with an iQDP Gas System Module Series 2 (harsh duty processes). iQ systems fitted with an iQDP Shaft-Seals Purge Module (light duty) or with an iQDP Gas-ballast Module (medium duty) are not ATEX compliant.

5.1.1 Introduction

This equipment is designed to meet the requirements of Group II Category 3 equipment in accordance with Directive 94/9/EC of the European Parliament and the Council of 23rd March 1994 on the approximation of the laws of the Member States concerning equipment and protective systems intended for use in potentially explosive atmospheres. (The ATEX Directive)

The ATEX Category 3 applies in respect of potential ignition sources internal to the equipment. An ATEX Category has not been assigned in respect of potential ignition sources on the outside of the equipment as the equipment has not been designed for use where there is an external potentially explosive atmosphere.

There is no potential source of ignition within the pump during normal operation but there may be potential sources of ignition under conditions of predictable and rare malfunction as defined in the Directive. Accordingly, although the pump is designed to pump flammable materials and mixtures, operating procedures should ensure that under all normal and reasonably predictable conditions, these materials and mixtures are not within explosive limits. Category 3 is considered appropriate for the avoidance of ignition in the case of a rare malfunction which allows flammable materials or mixtures to pass through the pump whilst within their explosive limits.

5.1.2 Flammable/pyrophoric materials

WARNING

You must obey the instructions and take note of the precautions given below, to ensure that pumped gases do not enter their flammable ranges.

When flammable or pyrophoric materials are present within the equipment you must:

- Not allow air to enter the equipment.
- Ensure that the system is leak tight.
- Use an inert gas purge (for example, a nitrogen purge) to dilute any flammable gases or vapours entering the pump inlet, and/or use an inert gas purge to reduce the concentration of flammable gases or vapours in the pump and in the exhaust pipeline to less than one quarter of the gases' published lower explosive limits (LEL).
- Use an inert gas purge in to the pump gas ballast connection to prevent the condensation of flammable vapours within the pump mechanism and exhaust pipeline.

5.1.3 Gas purges

WARNING

If you use inert gas purges to dilute dangerous gases to a safe level, ensure that the iQ system is shut down if an inert gas supply fails.

WARNING

You must obey the instructions and take note of the precautions given below, to ensure that pumped gases do not enter their flammable ranges.

Switch on the inert gas purge to remove air from the pump and the exhaust pipeline before the process starts. Switch off the purge flow at the end of the process only after any remaining flammable gases or vapours have been purged from the pump and exhaust pipeline.

If liquids that produce flammable vapours could be present in the pump foreline, then the inert gas purge to the iQDP pump should be left on all the time this liquid is present. Flammable liquids could be present in the foreline as a result of condensation, or may be carried over from the process.

When you calculate the flow rate of inert gas required for dilution, consider the maximum flow rate for the flammable gases/vapours that could occur. For example, if a mass flow controller is used to supply flammable gases to the process, you should assume a flow rate for flammable gases that could arise if the mass flow controller is fully open.

Continually measure the inert gas purge flow rate: if the flow rate falls below that required, you must stop the flow of flammable gases or vapours into the pump.

Note: We recommend that you obtain and read the Vacuum Pump and Vacuum System Safety manual (publication number P300-20-000), available from BOC Edwards or your supplier.

5.2 Introduction to operation

The following sections describe the use of the Pump Display Module to operate the iQ system. For a description of the use of an Interface Module accessory to operate the iQ system, refer to the instruction manual supplied with the Interface Module. For a description of the operation of the load-lock pump (if you have connected the iQ system to the load-lock pump through an Interface Module), refer to Section 5.15.

The following sections summarise the use of the menus in the Pump Display Module. We refer to menus such as 'the Setup/Service/Configuration menu'. This means that you:

- Press the Setup button to select the Setup menu.
- Use the up and down buttons to show the Service option and press ENTER to select the Service menu.
- Use the up and down buttons to show the Configuration option and press ENTER to select the Configuration menu.

We recommend that you fully understand the use of the Pump Display Module menus and buttons before you operate the iQ system. Refer to Section 4 which fully defines the menus, the use of the buttons and the display formats.

Note that you must switch on the electrical supply to the iQ system before you can use the Pump Display Module.

5.3 Configure the system

5.3.1 Change the setpoints

*Notes: The iQ pumping system is supplied with the iQDP80 power consumption setpoints preset for a 4 kW iQDP80. If you have an iQ system with an iQDP80 pump and you want to use the pump as a 6 kW pump, you **must** change the setpoints to the correct values: refer to Table 2-4.*

Unless you have changed the corresponding setpoints, nitrogen purge flow and pressure warning conditions will occur if the iQ pumping system is operated for extended periods with the inlet pressure close to atmospheric pressure.

If you want to adjust any setpoints, use the Setup/Setpoints menu. Note that you cannot enter setpoint data which is outside the valid range for the setpoint.

Refer to Table 5-1 (see page 5-4) for the setpoints which you can adjust with the Pump Display Module and the valid adjustment ranges. Refer to Tables 2-6 to 2-9 for the default values of the setpoints as supplied.

Parameter	Unit †	Valid adjustment range		
		Low warning	High warning	High alarm
iQDP40 power consumption	kW	*	0.0 to 7.6	0.0 to 7.6
iQDP80 power consumption	kW	*	0.0 to 7.6	0.0 to 7.6
iQMB250/500 power consumption	kW	*	0.0 to 7.6	*
iQMB1200 power consumption	kW	*	0.0 to 7.6	*
iQDP pump temperature	°C	30 to 90	50 to 150	60 to 150
Final stage nitrogen flow: 3/4-interstage purge off	slm	0 to 10	20 to 50	*
Final stage nitrogen flow: 3/4-interstage purge on	slm	12 to 50	20 to 60	*

† Only slm values are given in the table, because only slm values can be entered in the Pump Display Module. To convert slm values to Pa l s⁻¹, multiply by (1.013/60) x 10⁵.

* Not applicable: you cannot adjust these setpoints.

Table 5-1 - Setpoints which you can adjust with the Pump Display Module

5.3.2 Use the default setpoints

CAUTION

When you press the default button on the Electrics Module, the iQDP pump (and the iQMB pump, if fitted) is switched off and control is released.

Note: If you have an iQ Interface Module with a Tool Interface Card on your iQ system, the setpoints store in the Module will be automatically downloaded to the iQ system when you switch on. When you press the tool interface default button on the Module, the setpoints store in the Module will be cleared: refer to the instruction manual supplied with the iQ Interface Module.

After you have used the Pump Display Module (or another module) to change setpoints, if you want to use the default setpoints for a module to generate warning and alarm messages, use a suitable tool (for example, a small screwdriver) to press the default button on the corresponding module. When you press the default button, note that any changes you have already made to the setpoints in that module are lost.

The locations of the Gas-Ballast Module and Gas System Module default buttons are shown on Figure 3-12; the locations of the Sensor Monitoring Module PCA and the Electrics Module PCA default buttons are shown on Figure 1-8.

Note also that when you press the Electrics Module PCA default button:

- The pumps in the iQ system are switched off.
- Control of the iQ system is released from whichever Module had control.

5.3.3 Change iQ system configuration information

*Notes: You **must** configure the Gas Module type if you have replaced a Gas System Module with a Gas-Ballast Module or a Shaft-Seals Purge Module, or if you have replaced a Gas-Ballast Module with a Shaft-Seals Purge Module.*

If you have changed a component of the iQ system, enter the configuration information appropriate to the component. For example, if you have replaced the iQMB mechanical booster pump, you should enter the type of pump and its serial number.

The configuration information you can change is as follows:

- iQ system serial number
- iQDP pump serial number
- iQMB pump serial number
- Gas Module serial number
- iQ system configuration:
 - iQMB pump fitted/not fitted
 - Gas Module type: Shaft-Seals Purge Module, Gas-Ballast Module or Gas System Module
 - Sensor Monitoring Module configuration: exhaust temperature sensor fitted/not fitted, iQDP pump oil-level monitor fitted/not fitted, iQMB pump oil-level monitor fitted/not fitted.

Use the Setup/Service/Configuration menu to change configuration information.

5.4 Change the display format

5.4.1 Change the normal display

During normal operation (or whenever the Normal menu is selected), the Pump Display Module will show the first page of the normal display. The normal display has two pages and each page can show the readings of one or more sensors or internal clocks or counters. As supplied, the information shown on the first page is:

- iQDP pump power consumption
- iQDP pump-body temperature.

If you press the up or down button, the Pump Display Module will then show the second page of normal display; as supplied, the information shown on the second page is:

- iQMB pump power consumption
- iQMB pump-motor temperature.

If required, you can use the Setup/Normal display menu to change the information shown on the two normal display pages.

5.4.2 Change the pressure display units

Pressures shown on the Pump Display Module can be displayed in either kPa or psi units. Use the Setup/Units/Pressure menu to change the pressure display units.

5.4.3 Change the temperature display units

Temperatures shown on the Pump Display Module can be displayed in either degrees Centigrade or degrees Fahrenheit. Use the Setup/Units/Temperature menu to change the temperature display units.

5.4.4 Change the language of display messages

As supplied, all display messages shown on the Pump Display Module will be shown in English. If required, you can use the Setup/Messages menu so that display messages are shown in a different language. Note that you must download the foreign language messages to the Pump Display Module before you can use this facility.

5.5 Take and release control

To use the Pump Display Module to control the operation of the iQ system, the Local control LED on the Pump Display Module (Figure 1-9, item 8) must be on. If the LED is not on, use the Control menu to take control.

If you need to use another module (for example, the iQ Interface Module) to operate the iQ system, the Local control LED on the Pump Display Module (Figure 1-9, item 8) must be off. If the LED is on, use the Control menu to release control.

5.6 Start-up

WARNING

When the iQ system is on, you must only touch the appropriate controls on the iQ system to adjust the iQ (for example the TCV spindle on the iQDP pump). Do not touch other parts of the system. Surfaces of the pumps are very hot, especially at high inlet pressures, and can cause injury to people.

WARNING

Ensure that it is safe to start the pumping system. If you do not (and, for example, maintenance is being performed on components downstream of the iQ system), you can cause injury to people.

1. Switch on the cooling-water supply, the nitrogen supply and the external electrical supply (if not already on).

2. Ensure that the exhaust-extraction system is not blocked and that valves in the exhaust-extraction system are open.
3. Ensure that the Pump Display Module has control of the iQ system: refer to Section 5.5.
4. Refer to Figure 1-9. Look at the display (1) on the Pump Display Module:
 - If there are any warnings or alarms, take the necessary corrective action (refer to Section 6); do not start the iQ system.
 - If there are no alarms or warnings displayed, use the Switch On menu to switch on the iQ system.

When you switch on, the following actions will occur (with a small time delay between each action):

- The LED on the On button on the Pump Display Module will start to flash.
- The iQDP pump (and the iQMB pump, if fitted) will be switched on.
- The LED on the On button on the Pump Display Module will stay permanently on.
- The solenoid-valve(s) in the Gas Module will open to switch on the nitrogen supply to the pump.

5.7 Check the Gas Module nitrogen pressure and adjust if necessary

When the iQ system is on, we recommend that you regularly check and adjust the nitrogen pressure, to ensure optimum shaft-seals performance and to maximise the life of the shaft-seals:

- If a Shaft-Seals Purge Module is fitted, refer to Section 3.22.2.
- If a Gas-Ballast Module or Gas System Module is fitted, refer to Section 3.22.3.

5.8 Monitor the status of the iQ system

Notes: If you have selected the Status menu and then do not press any button for five minutes, the display will change to the Normal display: refer to Section 5.4. If required, you can use the Setup/Timeout menu to change the timeout time or switch off the timeout facility: refer to Section 4.

If a sensor is not fitted, the corresponding display line will show 'NP' (not present).

Use the Status menu or the Setup/Service/View Status menu to display sensor readings and the values of internal clocks and counters. The information that can be displayed (up to two items of information at a time) is shown in Table 5-2.

5.9 Warning and alarm indications

Notes: Refer to Section 6 for a full list of the warning and alarm messages and their meanings.

Unless you have changed the corresponding setpoints (see Section 5.3), nitrogen purge flow and pressure warning conditions will occur if the iQ pumping system is operated for extended periods with the inlet pressure close to atmospheric pressure.

If a warning or alarm condition exists:

- The top line of the display on the Pump Display Module will change to 'WARNING' or 'ALARM', together with an error number.
- The bottom line of the display will show the warning or alarm message or (for some errors) will be blank.
- The warning or alarm LED on the Pump Display Module will flash.

To acknowledge the warning or alarm, press the ENTER button. If the warning or alarm condition has cleared, the warning or alarm LED will go off. If the warning or alarm condition is still present:

- The warning or alarm LED will stay on.
- If the warning or alarm condition does not have an advisory message (see Section 6.21), the display will then change to normal display: see Section 5.4.
- If the warning or alarm condition has an advisory message (see Section 6.21), the display will show two lines which describe a simple check which you can make to identify the cause of the fault and to rectify the fault. When you have read the message, press the ENTER button again; the display will then change to normal display: see Section 5.4.

Sensor data	Units	Notes
iQDP pump current consumption *	A	
iQDP pump power consumption *	kW	
iQMB pump current consumption *	A	
iQMB pump power consumption *	kW	
Total running time *	hours	Total run-time of the iQ system.
Process running time * †	hours	Total run-time on process.
Process cycles * †	-	Process cycles.
iQ cycles *	-	The number of times the iQ system has been switched on/off.
iQMB pump-motor surface temperature *	°C/°F	
iQDP pump-motor surface temperature *	°C/°F	
Exhaust temperature *	°C/°F	
iQDP pump body temperature *	°C/°F	
iQDP pump oil-level	-	OK indicates the oil-level is acceptable; LOW indicates the oil-level is too low: see Section 6.
iQMB pump oil-level	-	As iQDP oil-level: see above.
Water flow	-	OK indicates the cooling-water flow is acceptable; LOW indicates the flow is too low: see Section 6.
Total nitrogen flow ♦	slm	Total nitrogen flow rate through the Gas Module.
Exhaust pressure *	kPa/psi	
Shaft-seals purge pressure *	kPa/psi	
Final stage purge nitrogen flow *♦	slm	The total shaft-seals purge and 3/4-interstage purge flow rate
Auxiliary nitrogen purge flow *♦	slm	The total 2/3-interstage purge, exhaust-purge and inlet-purge flow rate.
Pump stop time *	seconds	The time remaining before the iQDP pump is switched off (after auto shut-down selection).
Zero time *	seconds	The time remaining before the sensors are completely zeroed: refer to Section 6.20.
Valve 1 *	-	The open/shut state of the gate valve (if an iQ Interface Module which controls a gate valve is fitted).
Warning/ alarm messages #	-	Refer to Section 6 for a list of the messages

* These items of data can be selected to be displayed on the Normal display: refer to Section 5.4.

† These display items require signals from the process tool to indicate when the process is on and off, hence these items are only available if you have an iQ Interface Module.

♦ The difference between total nitrogen flow and (final stage purge nitrogen flow + auxiliary nitrogen purge flow) may be between 0.1 and 0.5 slm, due to sensor accuracies and software resolution.

These messages will be automatically displayed on the Normal display when a warning or alarm condition exists.

Table 5-2 - Status menu sensor reading displays

5.10 Manual shut-down

WARNING

If you intend to do maintenance on the iQ system after you have shut it down and you will not isolate the iQ system from the electrical supply, do not disconnect the Pump Display Module or release control from the Pump Display Module (see Section 5.5). If you do, the iQ system could be started by another Module.

Notes: Press the Cancel button on the Pump Display Module to cancel a shut-down request.

The purge time for the Auto shut-down option is preset to 15 minutes as supplied. This purge time can be configured for your application.

After you have selected auto shut-down, if required you can use the Status menu to view the time remaining before the iQDP pump is switched off.

Ensure that it is safe to shut down the iQ system before you select shut-down.

Use the Switch Off menu to shut down the iQ system. Note that the menu has two shut-down options: Fast and Auto.

If your iQ system has a Gas-Ballast Module or a Gas System Module, we recommend that you use the Auto shut-down option. This ensures that the iQ system is purged with nitrogen for 15 minutes before it is shut down. When you select Auto shut-down, the following actions will occur (with a small time delay between each action):

- The LED on the on button on the Pump Display Module will start to flash.
- If not already open, the inlet-purge, 2/3-interstage purge and 3/4-interstage purge solenoid-valves will open to switch on the nitrogen purges to the iQ system.
- After 15 minutes, the nitrogen supply, inlet-purge, 2/3-interstage purge and 3/4-interstage purge solenoid-valves will close to switch off the nitrogen purges to the iQ system.
- The iQDP pump (and the iQMB pump, if fitted) will be switched off.
- The LED on the On button on the Pump Display Module (Figure 1-9, item 10) will go off.

If you need to shut down the iQ system quickly (without purge), use the Fast shut-down option. When you select Fast shut-down, the following actions will occur (with a small time delay between each action):

- The iQDP pump (and the iQMB pump, if fitted) will be switched off.
- The solenoid-valve(s) in the Gas Module will close to switch off the supply of nitrogen to the iQ system.
- The LED on the On button on the Pump Display Module (Figure 1-9, item 10) will go off.

5.11 Automatic shut-down

WARNING

If a pump is automatically shut down, ensure that it is safe to restart it before you restart the pump.

CAUTION

If you select 'Run til crash', the pump(s) can be damaged and you may invalidate any warranties on the iQ system equipment.

Note: The emergency stop button, the emergency stop signal from your control equipment (if fitted) and the safety sensors will still shut down the iQ system, even if you have selected 'Run til crash'.

Normally, if an alarm condition exists, the Electrics Module will shut-down the iQ system. If required, you can request 'run til crash' operation. In this mode of operation, most alarm conditions will be ignored and the pump(s) will continue to operate. Note however that for safety reasons the following alarms will shut down the iQ system even if you have selected 'run til crash':

- QDP CURRENT HIGH/LOW (error numbers 310 and 312)
- EXHAUST PRESSURE (error number 3912)

The following alarms will cause only the iQMB pump (if fitted) to shut down, provided 'run til crash' is not set:

- QMB POWER HIGH (error numbers 810 and 812)
- QMB THERMISTOR HIGH (error number 912)
- QMB PHASE IMBALANCE (error 1012).

The following alarm will cause only the iQMB pump (if fitted) to shut down, whether 'run til crash' is set or not:

- QMB CURRENT HIGH/LOW (error numbers 710 and 712)

Use the Setup/Run Til Crash menu to select 'run til crash'.

5.12 Emergency stop

Notes: The emergency stop switch is not an electrical isolator.

The use of emergency stop will not automatically shut down the load lock pump (if fitted); you must shut down the load lock pump separately.

To shut down the iQ system in an emergency, press the emergency stop switch on the Electrics Module (Figure 1-5, item 4). Alternatively, you can operate the emergency stop controls in your own control system if you have connected your emergency stop circuit to the iQ system as described in Section 3.17.

When emergency stop is selected:

- The iQDP pump (and the iQMB pump, if fitted) is switched off.
- The solenoid-valve(s) in the Gas Module close, to switch off the supply of nitrogen to the iQ system.
- The Pump Display Module will display 'EMS PRESSED'.
- The LED on the On button on the Pump Display Module (Figure 1-9, item 10) will go off.

5.13 Restart after emergency stop or automatic shut-down

WARNING

If a pump is automatically shut down, ensure that it is safe to restart it before you restart the pump.

If you have used the emergency stop switch on the Electrics Module to shut down the iQ system, you must reset the emergency stop switch before you can restart the iQ system. Turn the emergency stop switch to reset it, then restart the iQ system as described in Section 5.6. Note that the 'EMS PRESSED' alarm message (see Table 6-3) will stay on the Pump Display Module until you restart the pumping system.

If the iQ system has been automatically shut down because of an alarm condition, the alarm condition must be rectified before you can restart the iQ system. For example, if the iQ system has been shut down because the iQDP pump-body is too hot, the pump-body must be allowed to cool before you can restart the pump. Restart the iQ system as described in Section 5.6.

If the iQMB pump only has been automatically shut down because of an alarm condition, you must stop the iQDP pump and rectify the alarm condition before you can fully restart the iQ system (that is, with both the iQDP and iQMB pumps operating). Shut down the iQ system as described in Section 5.10; restart the iQ system as described in Section 5.6.

5.14 Operation of iQ system components

WARNING

Ensure that it is safe to start the pumping system. If you do not (and, for example, maintenance is being performed on components downstream of the iQ system), you can cause injury to people.

CAUTION

If the iQDP pump is not on, do not operate the iQMB pump for more than a few seconds. If you do, you may pressurise the bellows between the iQMB pump outlet and the iQDP pump inlet and the bellows may fracture.

CAUTION

Ensure that you do not over-pressurise the vacuum system if you switch on purge gas flow when the iQDP pump is not on.

Note:s The gate valve must be connected to the iQ system through an iQ Interface Module with an Auxiliary Interface Card.

When you manually start the iQDP pump or the iQMB pump, the pump will only operate for ten seconds and will then automatically be switched off again.

In normal operating conditions, the components of the iQ system are operated automatically.

If necessary (for example, for fault finding purposes), you can control the operation of iQ system components (iQMB pump, Gas-Ballast Module or Gas System Module and gate valve) separately:

- Use the Setup/Service/Manual/QMB menu to control the operation of the iQMB pump (that is, switch the iQMB pump on and off).
- Use the Setup/Service/Manual/Gas Module menu to control the operation of the Gas Module (that is, turn the nitrogen supply, gas-ballast and inlet-purge flows on and off).
- Use the Setup/Service/Manual/Valve menu to control the operation of the gate valve (that is open or close the valve).
- Use the Setup/Service/Manual/QDP Only menu to control the operation of the iQDP pump (that is, switch the iQDP pump on and off).

5.15 Operation of the load-lock pump

If you have connected a load-lock pump to the iQ system through an Interface Module, you can use the following menus to control the operation of the load-lock pump:

- Switch On.
- Switch Off.
- Setup/Service/Manual/Load lock pump.

6 MAINTENANCE

6.1 Safety

WARNING

Obey the safety instructions given below and take note of appropriate precautions. If you do not, you can cause injury to people and damage to equipment.

- A suitably trained and supervised technician must maintain the iQ system.
- Ensure that the maintenance technician is familiar with the safety procedures which relate to the products pumped. Wear the appropriate safety-clothing when you come into contact with contaminated components. Dismantle and clean contaminated components inside a fume-cupboard.
- Allow the pumps to cool to a safe temperature before you start maintenance work.
- Vent and purge the iQ system with nitrogen before you start any maintenance work.
- Isolate the iQ system and other components in the process system from the electrical supply so that they can not be operated accidentally. Note that the emergency stop switch on the iQ system is **not** an electrical isolator.
- Recheck the pump rotation direction if the electrical supply has been disconnected.
- The frequency at which you should replace 'O' rings depends on your application. If necessary, contact your supplier or BOC Edwards for advice.
- Do not reuse 'O' rings or 'O' ring assemblies.
- Dispose of components, grease and oil safely (see Section 7.2).
- Take care to protect sealing-faces from damage.
- Do not touch or inhale the thermal breakdown products of fluorinated materials which may be present if the iQ system has been overheated to 260 °C and above. These breakdown products are very dangerous. Fluorinated materials in the iQ system may include oils, greases and seals. The iQ system may have overheated if it was misused, if it malfunctioned or if it was in a fire. BOC Edwards Material Safety Data Sheets for fluorinated materials used in the pump are available on request: contact your supplier or BOC Edwards.
- Leak-test the system after maintenance work is complete if you have connected or disconnected any vacuum or exhaust joints; seal any leaks found.
- Wipe up any water, Drystar coolant or oil spilt during maintenance, so that people cannot slip over any spillages.
- Safely route and secure all cables, hoses and pipes during maintenance, so that people cannot trip over them.
- Fit a suitable blanking-plate to the iQ system inlet and to your vacuum system outlet as soon as you have disconnected the iQ system from your vacuum system. Do not operate the iQ system unless the blanking-plate is fitted to the iQ system inlet, or the iQ system is connected to your vacuum system.
- Fit a suitable blanking-plate to the iQ exhaust check-valve outlet and to your exhaust-extraction system inlet as soon as you have disconnected the iQ system from your exhaust-extraction system. Do not operate the iQ system unless the iQ system is connected to your exhaust-extraction system.

6.2 Maintenance plan

The plan in Table 6-1 lists the maintenance operations we recommend to maintain the iQ system in normal operation. Instructions for each operation are given in the section shown.

When you maintain the iQ system, use BOC Edwards maintenance and service kits. These contain all of the necessary seals, lubricating grease and other components necessary to complete maintenance operations successfully. The Item Numbers of the service kits are given in Section 8.3.2.

In practice, the frequency of maintenance is dependent on your process. In clean processes, you may be able to decrease the frequency of maintenance operations; in harsh processes you may have to increase the frequency of maintenance operations. Adjust the maintenance plan according to your experience.

Operation	Frequency	Refer to Section
Inspect the connections, pipelines and cables	Monthly	6.3
Inspect and clean the exhaust-silencer	3 monthly	6.4
Check the iQMB pump oil-level	3 monthly	6.5
Inspect and clean the exhaust check-valve	6 monthly	6.6
Check the iQDP pump oil-level	6 monthly	6.7
Check the iQDP pump coolant-level	6 monthly	6.8
Relubricate the iQDP pump rotor bearings	Yearly	6.9
Relubricate the iQMB pump rotor bearings (iQMB250F and iQMB500F only)	Yearly	6.10
Change the iQDP pump oil	Yearly or when contaminated *	6.11
Change the iQMB pump oil	Yearly or when contaminated *	6.12

* If the oil is not contaminated, you may only need to change the oil once a year. If there is contamination (indicated by a change in colour of the oil; for example, water contamination will turn the oil a white colour), you must change the oil. You may be able to remove the contaminants from the oil by filtration.

Table 6-1 - Maintenance plan

6.3 Inspect the connections, pipelines and cables

1. Check that all the cooling-water connections are secure; tighten any loose connections. Inspect all cooling-water pipelines and connections and check that they are not corroded or damaged and do not leak; replace any pipelines and connections that are corroded or damaged or leak.
2. Check that all the nitrogen connections are secure; tighten any loose connections. Inspect all nitrogen pipelines and connections and check that they are not corroded or damaged and do not leak; replace any pipelines and connections that are corroded or damaged or leak.

3. Check that all electrical connections are secure; tighten any loose connections. Inspect all electrical cables and connectors for damage; replace any cables and connectors that are damaged.
4. Check that all process and exhaust connections are secure; tighten any loose connections. Inspect all process and exhaust pipelines and check that they are not corroded or damaged; replace any pipelines that are corroded or damaged.
5. If you have a booster frame mounted iQDP/iQMB pumping system:
 - Inspect the bolts which secure the booster frame and ensure that they are tight; tighten any loose bolts.
 - Inspect the castors and levelling feet and check that they are securely fitted to the booster frame; if necessary, tighten them.

6.4 Inspect and clean the exhaust-silencer

WARNING

The substances which accumulate in the exhaust-silencer can be dangerous. Do not allow these substances to come into contact with your skin or eyes. Do not inhale vapours from these substances. Fit blanking caps to the inlet and outlet flanges when you move the silencer around your workplace.

Refer to Figure 6-1 and dismantle, inspect and clean the silencer as described below.

1. Release the NW40 clamps at the silencer inlet and outlet flanges to disconnect the silencer from the exhaust pipeline and from the pump.
2. Slide the silencer out towards the high-vacuum end of the pump to remove the silencer from the pump. Alternatively, undo the two support-plate retaining screws (see Figure 1-5) and slide the silencer complete with the support-plate towards the motor end of the pump.
3. Weigh the silencer. If the mass of the silencer is greater than 7.5 kg, dismantle, clean and reassemble the silencer as in Steps 4 to 9 below. If you do not need to clean the silencer, refit the silencer as in Step 12.
4. Remove and retain the six bolts and washers which secure each end-cover plate to the silencer body. Pull the end-cover plates squarely from the outlet pipe to remove them.
5. Remove the three 'O' rings from the silencer and discard.
6. Empty all loose deposits from the silencer body; take care not to damage the end-cover plate sealing surfaces.
7. Use a suitable tool to dislodge remaining deposits, then wash the silencer body with steam or water. Finally, glass-bead blast the silencer body. If required, use a cleaning solution suitable for the nature of the deposits.
8. Inspect the silencer for internal corrosion and check that the wall of the silencer body is not excessively eroded. Inspect the end-cover plate and inlet and outlet flange sealing-faces for damage and refinish if necessary. If silencer damage is excessive, it should be replaced.

(Continued on page 6-5)

- 1. Cap-head bolt
- 2. Washer
- 3. End-cover plate
- 4. 'O' ring
- 5. Silencer body
- 6. Transfer tube
- 7. 'O' ring
- 8. 'O' ring
- 9. End-cover plate
- 10. Outlet flange
- 11. Inlet flange
- 12. Outlet tube

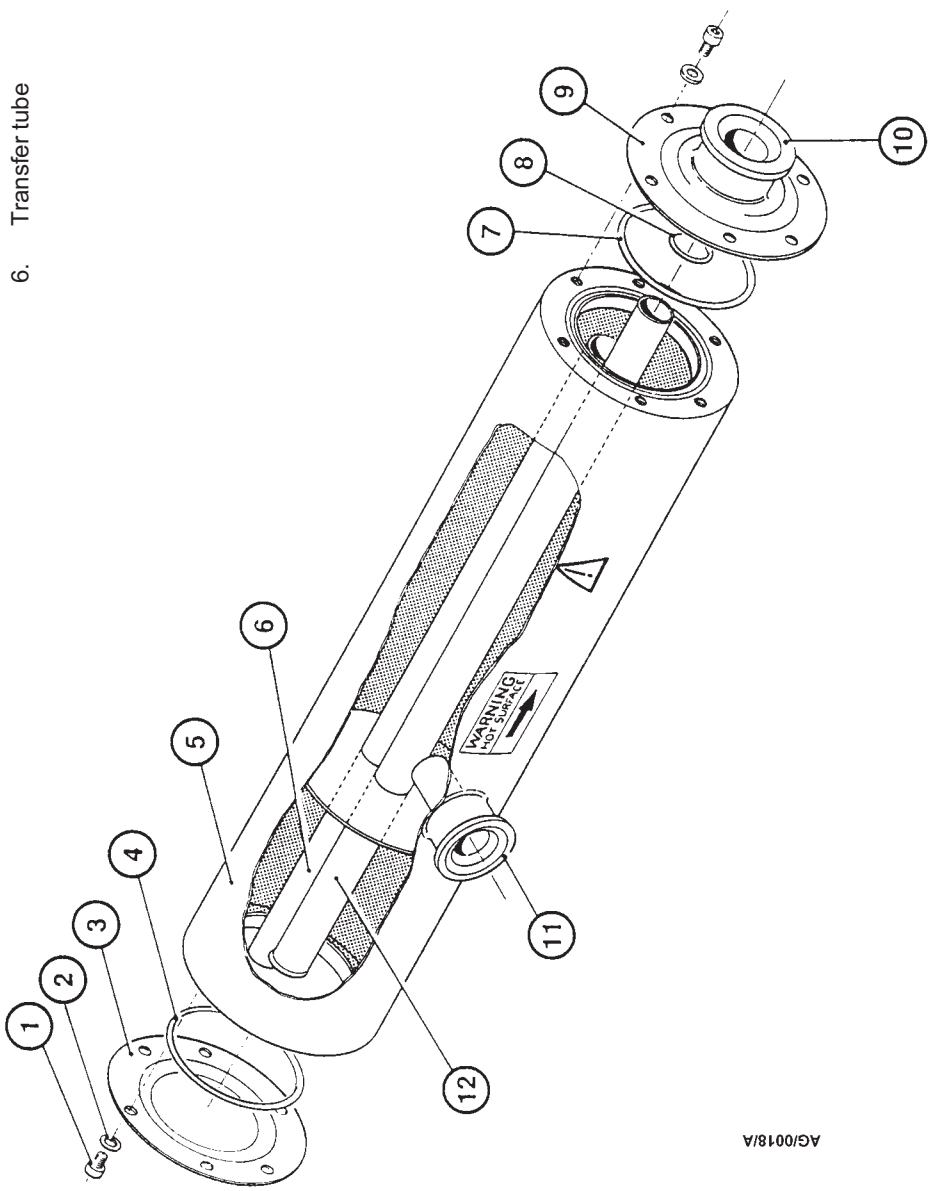

AG/0018/A

Figure 6-1 - Exhaust-silencer

9. Check that the 'O' ring grooves are clean. Apply a light wipe of vacuum grease and place the new 'O' rings in position.
10. Refit the end-cover plates and secure with the bolts and washers removed in Step 3. Tighten the bolts progressively; alternate between bolts on opposite sides of the end-cover plate. Tighten to a torque of 10 Nm.
11. Leak-test the silencer.
12. Slide the silencer in from the high-vacuum end of the pump. Alternatively, slide the silencer complete with the support-plate in from the motor end of the pump and tighten the support-plate retaining screws (see Figure 1-5).
13. Reconnect the silencer to the pump and to the exhaust pipeline with the new NW40 clamps and trapped 'O' rings supplied in the servicing kit.

6.5 Check the iQMB pump oil-levels

CAUTION

Ensure that the oil-levels in the pump are correct. If an oil-level is incorrect, pump performance may be affected and the pump may be damaged.

Note: If there is a loss of oil from the shaft-seal reservoir, the shaft-seal may have failed. The shaft-seal cannot be replaced by the user. Contact your supplier or a BOC Edwards Service Centre for advice.

Check the oil-levels in the sight-glasses as described below. Refer to Figure 3-2 for the location of the oil filler-plugs and sight-glasses. During normal operation, the coupling-cover sight-glass (Figure 3-3, item 3) may appear empty or show a froth because the oil is in circulation around the coupling.

1. Shut down the iQ system and allow it to cool.
2. Check that the coupling-cover oil-level is correct. If necessary, add more oil: refer to Section 3.8
3. Check that the shaft-seal reservoir oil-level is correct. If necessary, add more oil: refer to Section 3.8.
4. On iQMB1200F pumps only, check that the oil-level in the rear-bearing end-cover is at the middle of the reflector plate in the end-cover sight-glass. If necessary, add more oil: refer to Section 3.8.

6.6 Inspect and clean the exhaust check-valve

WARNING

The substances which accumulate in the check-valve can be dangerous. Do not allow these substances to come into contact with your skin or eyes. Do not inhale vapours from these substances. Fit blanking caps to the inlet and outlet flanges when you move the check-valve around your workplace.

You must remove the exhaust check-valve from the silencer and your exhaust-extraction system before you can inspect it. It is convenient, therefore, to inspect the exhaust check-valve at the same time as you inspect the exhaust-silencer (see Section 6.4).

Use the procedure below to remove and inspect the valve. This procedure assumes that the exhaust-silencer has already been disconnected from the pump and the exhaust check-valve has been removed. Figure 6-2 shows the component parts of the exhaust check-valve.

1. Release the NW40 clamp at the exhaust check-valve outlet flange and remove the check-valve from the system pipeline.
2. Unscrew the two halves (2, 4) of the check-valve body; use a strap wrench if necessary.
3. Remove the fluoroelastomer ball (3) and the 'O' ring (6).
4. Use a cleaning solution suitable for the process products pumped to clean the valve body and the fluoroelastomer ball. If necessary, replace the fluoroelastomer ball with a new one.
5. Inspect the 'O' ring groove and the KF40 flange sealing-faces for damage and refinish if necessary.
6. Apply a light wipe of vacuum grease and position the 'O' ring (6) in its groove in the valve body (4).
7. Ensure that the fluoroelastomer ball is positioned correctly and screw the two halves of the valve body (2, 4) together.
8. Refit the valve to the system pipeline with the NW40 clamp and trapped 'O' ring. Ensure that the flow direction arrow points away from the exhaust-silencer (towards your exhaust-extraction system).

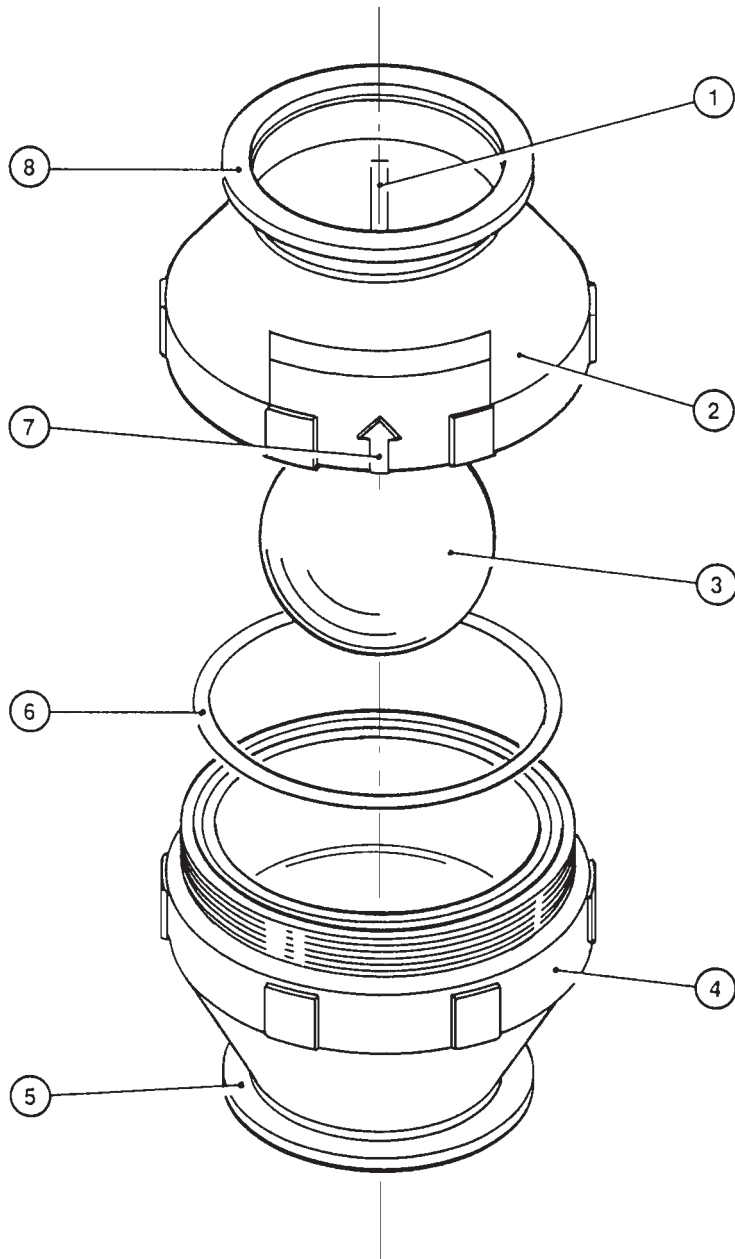

AG/0019/A

- | | |
|-------------------------|-----------------------------|
| 1. Spider leg | 5. Inlet-flange |
| 2. Valve body (female) | 6. 'O' ring |
| 3. Fluoroelastomer ball | 7. Mounting direction arrow |
| 4. Valve body (male) | 8. Outlet-flange |

Figure 6-2 - Exhaust check-valve

6.7 Check the iQDP pump oil-level

WARNING

Do not remove the oil filler-plug when the pump is operating. If you do, hot oil may be ejected from the pump gearbox.

Refer to Figure 3-4 and check that the pump gearbox oil-level is between the MIN and MAX marks on the bezel of the oil-level sight-glass. If the oil-level is above the MAX mark, drain excess oil from the pump as described in Section 6.11 until the oil-level is correct. If the oil-level is below the MIN mark:

1. Unscrew and remove the oil filler-plug (3).
2. Pour oil into the gearbox until the oil-level is at the MAX mark on the bezel of the oil-level sight-glass (13).
3. Make sure that the bonded seal is in place on the oil filler-plug. Screw the filler-plug back in and tighten by hand. Use a spanner to tighten a further $\frac{1}{16}$ th of a turn.

The gearbox is vented and the loss of a small amount of oil during operation is normal. If you need to pour oil into the gearbox frequently, or if there is a sudden loss of a large amount of oil, this may indicate that the pump has a fault. In these circumstances, we recommend that you shut down the iQ system as soon as possible and contact your supplier or BOC Edwards for advice.

6.8 Check the iQDP pump coolant-level

WARNING

Do not remove the combined filler-plug/level indicator when the iQDP pump is hot. If you do, hot coolant may be ejected from the header-tank and could cause injury.

CAUTION

Fill the iQDP pump with the correct type and amount of coolant. If you do not, the pump may overheat and it may not work correctly.

The coolant cools the iQDP pump and also acts as a corrosion inhibitor and anti-scaling agent. Check the coolant-level and if necessary fill the pump with coolant as described below; new coolant is available as a spare: refer to Section 8.3. The locations of the components of the cooling-water system are shown in Figure 3-4.

1. Isolate the iQ system from the electrical supply and ensure that the cooling-water supply is off.

2. Unscrew and remove the combined filler-plug/level indicator (5). Use a clean lint-free cloth to wipe the shaft of the indicator, then refit the combined filler-plug/level indicator in the coolant header-tank.
3. Remove the combined filler-plug/level indicator again and check the coolant-level: the coolant-level must be visible on the shaft of the indicator, but must not be above the notch mark on the indicator shaft. If the coolant-level is acceptable, continue at Step 12, otherwise continue at Step 4.
4. Remove the cap from a container of pump coolant and pour in de-ionised water until the 2.1 litre fill line on the container is reached.
5. Refit the cap firmly on the container. Shake the container gently to fully mix the fluids.
6. Check that the coolant drain-plug on the underside of the pump is securely fitted.
7. Fit a length of transparent flexible hose to the air bleed-valve, then unscrew the air bleed-valve (7).
8. Use a clean funnel to slowly fill the pump with the coolant mixture until the coolant fluid starts to flow through the hose fitted to the air bleed-valve.
9. Tighten the air bleed-valve (7), then remove the flexible hose.
10. Continue to fill the system slowly until you see the fluid in the bottom of the coolant header-tank (4).
11. Refit the combined filler-plug/level indicator (5) and then remove it to check the fluid-level on the shaft of the indicator: refer to Step 3.
12. Check that the bonded seal on the combined filler-plug/level indicator (5) is in place. Refit and tighten the combined filler-plug/level indicator.

6.9 Relubricate the iQDP pump rotor bearings

Relubricate the rotor bearings as described below. Figure 6-3 shows the location of the rotor bearings components.

1. Remove the six screws (2) which secure the bearing end-cover (1) to the high vacuum head-plate (4).
2. Lift away the end-cover and remove the sealing 'O' ring (3). Dispose of the 'O' ring (see Section 7.2).
3. Use clean, lint-free cloth, or a plastic or wooden spatula to remove as much old grease as possible from the end-cover and bearings. Do not use your fingers for this operation.
4. Inspect the bearings for obvious signs of wear or the presence of debris. If the bearings are worn, return the pump to a BOC Edwards Service Centre for repair.
5. If the bearings are in a satisfactory condition, force new PFPE grease (supplied in the maintenance kit) into the bearings so that a smooth layer of grease covers the case and bearings. Do not over-pack the bearings or the pump will run hot.
6. Apply a light wipe of PFPE grease to the new 'O' ring seal and position it in its groove in the head-plate. Refit the end-cover to the high vacuum head-plate.

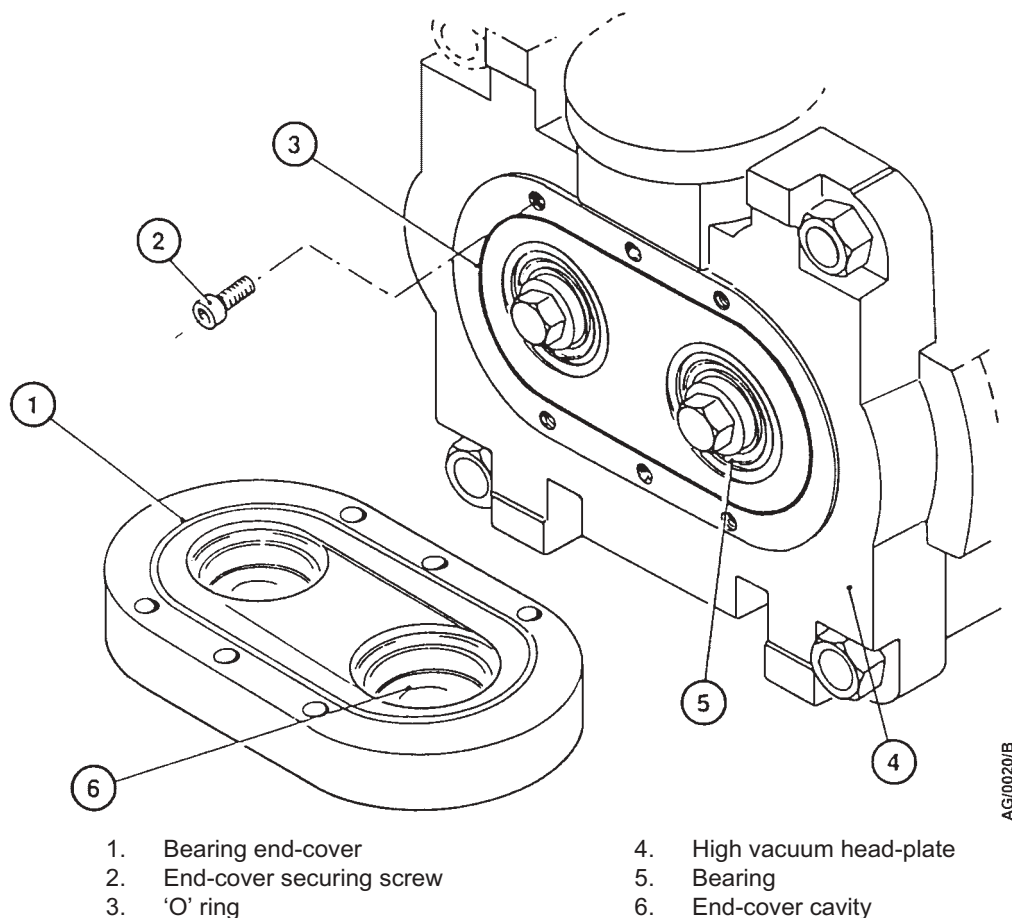
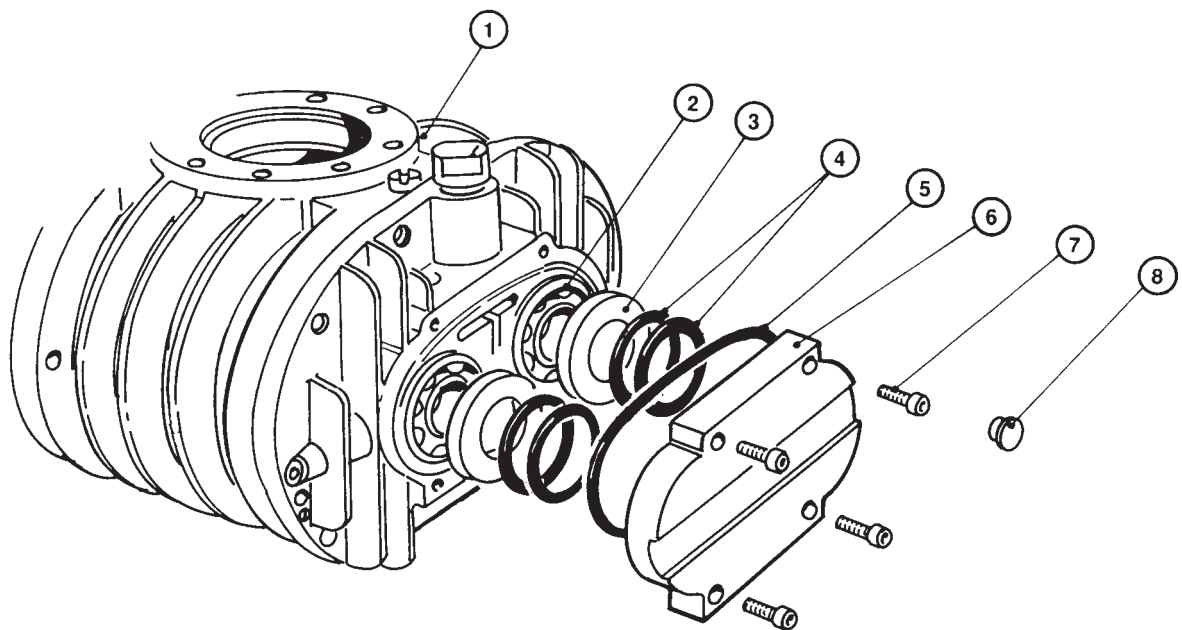

Figure 6-3 - iQDP pump rotor bearing relubrication

6.10 Relubricate the iQMB pump rotor bearings (iQMB250F & iQMB500F only)

1. Shut down the iQ system and isolate it from the electrical supply. Vent the iQMB pump to atmospheric pressure.
2. Refer to Figure 6-4. Remove the four plastic cover-caps (8) from the rear of the end-cover (6).
3. Undo and remove the socket-head screws (7) located under the four plastic cover-caps.
4. Remove the end-cover (6) and 'O' ring (5). Dispose of the 'O' ring safely.
5. Note the exact location of the shims (4) and spacers (3) inside the end-cover (6). Clean off all visible grease from the end-cover; take care not to misplace or damage the shims and spacers.
6. Use a soft, clean, lint-free cloth to remove all visible grease from both bearings (2).
7. Fill the visible side of each bearing (2) with clean grease.
8. Apply a light wipe of high-vacuum grease to the new 'O' ring (5) and fit it into the groove in the pump head-plate (6).
9. Check that the shims (4) and spacers (3) are correctly located in the end-cover (6).
10. Fit the end-cover (6) and secure with the four socket-head screws (7); tighten the screws evenly. Refit the plastic cover-caps (8).



AG/2669/A

- | | |
|--------------|----------------------|
| 1. Pump-body | 5. 'O' ring |
| 2. Bearing | 6. Bearing cover |
| 3. Spacer | 7. Socket-head screw |
| 4. Shims | 8. Cover-cap |

Figure 6-4 - iQMB pump rear bearing relubrication

6.11 Change the iQDP pump oil

1. Remove the oil filler-plug (see Figure 3-4).
2. Use a suitable pump or syringe to suck the oil out of the gearbox.
3. Discard the old bonded seal on the oil filler-plug and replace with a new one from the pump maintenance kit.
4. Fill the gearbox through the filler hole, with the correct grade and quantity of oil. Allow the oil to drain into the gearbox and then check the level on the oil sight-glass (refer to Section 3.10).
5. Ensure that the new bonded seal is positioned correctly and refit the oil filler-plug.

6.12 Change the iQMB pump oil

WARNING

Ensure that the correct vented filler-plug is refitted in the shaft-seal reservoir. If you use a non-vented plug, the reservoir will be pressurised and the oil sight-glass may fracture.

CAUTION

Ensure that the oil-levels in the pump are correct. If an oil-level is incorrect, pump performance may be affected and the pump may be damaged.

Change the pump oil as described below. Refer to Figure 3-2 for the location of the oil-filler and drain-plugs.

1. Shut down the iQ system and allow it to cool.
2. Refer to Figure 3-2. Remove the coupling-cover oil filler-plug (17).
3. Remove the coupling-cover oil drain-plug (9) from the underside of the coupling-cover, allow the oil to drain into a suitable container, then refit the oil drain-plug. Alternatively, if you cannot easily access the drain-plug (for example, if you have a direct mounted iQMB pump), use a suitable pump to suck the oil out of the coupling-cover.
4. Remove the shaft-seal vented oil filler-plug (16). Use a suitable pump to suck the oil out of the shaft-seal reservoir.
5. Fill the coupling-cover reservoir with new oil: refer to Section 3.8. Refit the coupling-cover oil filler-plug.
6. Fill the shaft-seal reservoir with new oil: refer to Section 3.8.
7. Refit the shaft-seal vented oil filler-plug (16).

8. On iQMB1200F pumps only:
 - Remove the oil filler-plug (5) on the rear-bearing end-cover (4); take care not to accidentally remove the plug from the external evacuation port (3).
 - Remove the drain-plug (6) from the underside of the end-cover and allow the oil to drain into a suitable container.
 - Refit the drain-plug (6) and pour PFPE oil into the end-cover until the oil-level reaches the middle of the reflector plate in the sight-glas (7)s.
 - Refit the filler-plug (5).

6.13 Adjust the Pump Display Module display viewing angle

If the display (Figure 1-9, item 1) is difficult to see, use the following procedure to adjust the display viewing angle. Refer to Figure 1-10.

1. Place or hold the Pump Display Module in its normal operating position.
2. Turn the display adjuster (1) clockwise or anticlockwise until the display is easy to read.

6.14 Replace an Electrics Module fuse

WARNING

Do not remove the cover from the Electrics Module. High voltages exist in the Electrics Module when it is connected to the electrical supply, and there are no parts which you can service in the Module.

WARNING

Ensure that you replace a fuse with a new fuse of the correct rating. If you do not, the iQ system will not be adequately protected and you can damage the iQ system or cause injury to people.

You can only change the low voltage fuses for the Gas Module, iQ Interface Module and emergency stop circuit. If any of the high voltage fuses have failed, you must contact your supplier or BOC Edwards for advice. Only change a fuse if you have identified and rectified the cause of the failure.

To change a fuse, refer to Figure 1-7 and use the following procedure. If the fuse immediately fails when you replace it, there may be an electrical fault: contact your supplier or BOC Edwards for advice.

1. Remove the fuse holder (1, 2 or 3) from the Electrics Module, then remove the failed fuse from the fuse holder.
2. Fit a new fuse of the correct rating in the fuse holder. Refer to Section 2 for the fuse ratings.
3. Refit the fuse holder in the Electrics Module.

6.15 Replace the Gas Module

WARNING

Hold the Gas Module by the frame when you remove or fit it. Do not handle it by the gas pipelines, or you may damage the Gas Module.

6.15.1 Remove the old Gas Module

1. Shut down the iQ system as described in Section 5.10 and allow the iQ system to cool down.
2. Switch off your nitrogen supply and disconnect your nitrogen supply pipeline from the nitrogen supply connector on the front of the Gas Module (see Figures 3-11 and 3-12).
3. Refer to Figure 6-5. If you replace a Gas-Ballast Module or a Gas System Module with a new Gas Ballast Module or a new Gas System Module, remove the connectors on the two network cables from the sockets (7, 8) on the side of the Gas Module. Leave the other ends of the network cables in place.
4. If you replace a Gas-Ballast Module or a Gas System Module with a Shaft-Seals Purge Module:
 - Remove the connectors on the two network cables from the sockets (7, 8) on the side of the Gas Module.
 - Remove the connector on the end of the network cable (from the Gas Module to the Sensor Monitoring Module) from the network connector on the Sensor Monitoring Module. Remove the network cable and retain for future use.
5. If you have a Gas-Ballast Module or a Gas System Module fitted to the pump:
 - Undo and remove the three bolts (6) which secure the side panel (5) on the Gas Module, then remove the side panel.
 - Disconnect the braided earth (ground) wire from the side panel.
6. Remove the plug on the end of the electrical supply cable (1) from the connector on the Electrics Module (Figure 1-7, item 7).
7. Undo the nut (12) on each of the gas pipelines (11) in the iQDP enclosure which are connected to the currently fitted Gas Module.
8. Undo the nut (13) and remove the nut and washer from each of the bulkhead fittings (15) which are connected to the currently fitted Gas Module.
9. Remove the four fixing bolts (4) from the fixing-holes on the front of the Gas Module and pull the Gas Module (3) out of the iQDP enclosure.
10. Undo the compression fitting nut (9) and remove each of the bulkhead fittings (15) from the rear of the Gas Module.
11. If you have removed a Gas-Ballast Module or a Gas System Module, refit the side panel (5) and secure with the three bolts (6).

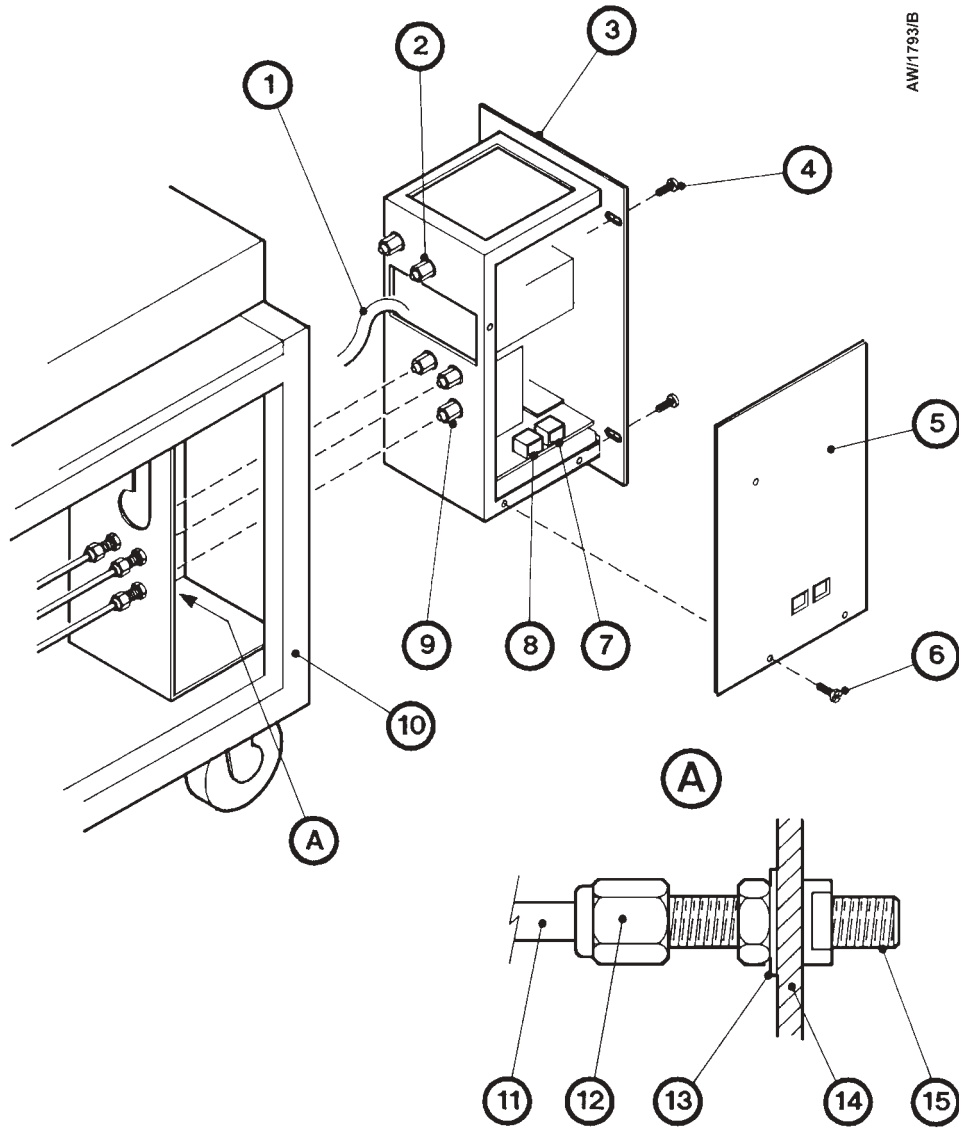

- | | |
|----------------------------|-------------------------|
| 1. Electrical supply cable | 9. Nut |
| 2. Exhaust-purge outlet | 10. iQDP pump frame |
| 3. Gas module | 11. Gas pipeline |
| 4. Bolt | 12. Nut |
| 5. Side panel | 13. Nut and washer |
| 6. Bolt | 14. Pump frame bulkhead |
| 7. Network connector | 15. Bulkhead fitting |
| 8. Network connector | |

Figure 6-5 - Fit the Gas Module (Gas System Module shown)

6.15.2 Fit the new Gas Module

Note: When you fit a Gas System Module Series 2 to an iQ system with a restricted bulkhead fitting (indicated by an 'O' ring on the fitting), you must replace the restricted bulkhead fitting with the non-restricted bulkhead fitting supplied with the Gas System Module Series 2.

1. Refer to Figure 6-5. If you will fit a Gas-Ballast Module or a Gas System Module Series 2, undo and remove the three bolts (6) which secure the side panel (5), then remove the side panel.
2. If you replace a Shaft-Seals Purge Module with a Gas-Ballast Module or a Gas System Module Series 2, remove the other bulkhead fittings (15) which will be fitted to the new Gas Module from the iQDP enclosure: refer to Steps 7 and 8 of Section 6.15.1.
3. Fit the bulkhead fittings (15) to each of the gas connectors on the rear of the new Gas Module and tighten the compression fitting nuts (9). Ensure that you fit the bulkhead fitting which has an 'O' ring to the exhaust-purge outlet (2) on the Gas Module.
4. Refit each bulkhead fitting (15) not used by the new Gas Module to the iQ enclosure:
 - Fit the bulkhead fitting (15) to the bulkhead (14); secure with the nut and washer (13).
 - Use the nut (12) to secure the enclosure gas pipe (11) to the bulkhead fitting (15).
 - Fit a blanking plug (refer to Section 8) to each of the unused bulkhead fittings (15).
5. Pass the electrical supply cable (1) on the Gas Module through the leadthrough hole in the bulkhead (14). Fit the connector on the end of the cable to the connector on the Gas Module.
6. Push the Gas Module into the enclosure; ensure that the bulkhead fittings (15) fitted to the rear of the Gas Module pass through the leadthrough holes in the bulkhead (14).
7. For each of the bulkhead fittings fitted to the Gas Module, use the washer and nut (13) to secure the bulkhead fitting (15) to the bulkhead (14), then use the compression nut (12) to secure the enclosure gas pipe (11) to the bulkhead fitting (15).
8. Use the four fixing bolts (4) to secure the Gas Module in the iQDP enclosure.
9. If you have fitted a Gas-Ballast Module or a Gas System Module Series 2, connect the braided earth (ground) wire to the side panel (5), then refit the side panel to the Gas Module and secure with the three bolts (6).
10. If you have replaced a Gas-Ballast Module, a Gas System Module, or a Gas System Module Series 2 with a new Gas-Ballast Module or Gas System Module Series 2, fit the connectors on the end of the network cables to the network connectors (7, 8) on the side of the Gas Module.
11. If you have replaced a Gas-Ballast Module, a Gas System Module or a Gas System Module Series 2 with a Shaft-Seals Purge Module, fit the connector on the end of the network cable (connected to the front panel of the iQ system) to a network connector on the Sensor Monitoring Module

12. If you have replaced a Shaft-Seals Purge Module with a Gas-Ballast Module or a Gas System Module Series 2:
 - Remove the connector on the end of the network cable (connected to the front panel of the iQ system) from the network connector on the Sensor Monitoring Module.
 - Fit the connector (removed from the Sensor Monitoring Module) to one of the network connectors (7, 8) on the side of the Gas Module.
 - Fit the connector on one end of the network cable supplied with the Gas Module to a network connector on the Sensor Monitoring Module. Fit the connector on the other end of the network cable to the other network connector (7, 8) on the Gas Module.
13. If necessary, reconfigure the iQ system for the new Gas Module: refer to Section 5.3.

6.16 Replace the Pump Display Module

Use the following procedure to replace the Pump Display Module. Note that you do not need to switch off the iQ system to replace the Pump Display Module.

1. Remove the connector on the cable (Figure 1-10, item 5) from the Pump Display Module connector on the front panel of the iQ system (Figure 1-5, item 6).
2. Fit the new Pump Display Module as described in Section 3.9.2.

6.17 Relocate the iQ combination pumping system for maintenance

WARNING

Use suitable lifting equipment to move the iQ system.

WARNING

Do not use the lifting bolts on the iQMB pump to move an iQDP/iQMB combination pumping system. If you do, the bolts may break and you can damage the iQ system or cause injury to people.

Note: If you just want to remove the iQDP pump from an iQ combination pumping system (that is, leave the iQMB pump fitted to your vacuum system), refer to the iQMB Booster Frame Connection Kits instruction manual.

If you want to remove the iQ system from its operating location and move it to another location where you will do maintenance, use the following procedure.

1. Purge the iQ system and shut down the iQ system as described in Section 5.6 and allow the pumps to cool down.

(Continued on page 6-18)

2. Disconnect the inlet of the iQMB pump from your vacuum system and disconnect the outlet of the iQ system from your exhaust-extraction system. Fit blanking caps to your process and exhaust-extraction pipelines and to the inlet and outlet of the iQ system.
3. Switch off your nitrogen and cooling-water supplies, then disconnect the nitrogen supply pipeline and the cooling-water supply and return pipelines from the connectors on the front of the iQ system (refer to Figure 1-5).
4. Adjust the levelling feet so that the iQ system rests on the castors.
5. Move the iQ system to the location where you will do maintenance. If you have an iQ combination pumping system, do not use the lifting bolts on the iQMB pump:
 - If you have an iQ direct mounted combination pumping system, attach suitable lifting equipment to the lifting bolts on the iQDP pump frame to move the iQ system.
 - If you have an iQ booster frame mounted combination pumping system, attach suitable lifting equipment to the lifting bolts on the booster frame to move the iQ system.

After maintenance is complete:

1. Move the iQ system back into its operating position as described above.
2. Reconnect the nitrogen and cooling-water supplies to the iQ system as described in Sections 3.14 and 3.20.
3. Connect the inlet of the iQ system to the vacuum system: refer to Section 3.12.
4. Connect the outlet of the iQ system to the exhaust-extraction system: refer to Section 3.13.

6.18 Replace the iQMB pump

Use the following procedure to replace the iQMB pump in an iQ/iQMB combination pumping system.

1. Shut down the iQ system and move it to the location where you will change the iQMB pump as described in Section 6.17.
2. Remove the connectors on the cooling-water supply and return hoses from the connectors on the front of the iQ system (Figure 1-5, items 8 and 9).
3. Fit a spare pair of quick-connectors to the connectors on the front of the iQ system (Figure 1-5, items 8 and 9) and allow the cooling-water to drain from the iQ system.
4. If the iQ system is mounted in a booster frame, remove the connectors on the cooling-water hoses from the connectors on the iQMB water-cooling manifold (Figure 3-2, item 1 or 2). Continue at Step 6.
5. If the iQMB pump is mounted directly on the iQDP pump, disconnect the cooling-water hoses from the cooling-water manifold on the iQDP pump: see Figure 3-4.
6. Refer to Figure 1-7. Remove the connector on the iQMB electrical supply cable from the iQMB electrical supply connector (6) on the rear of the Electrics Module.
7. Remove the connector on the end of the iQMB thermistors cable from the iQMB thermistors connector (9) on the rear of the Electrics Module.

8. Remove the connector on the end of the iQMB pump-motor surface temperature sensor cable from the connector on the Sensor Monitoring Module (Figure 1-8, item 25).
9. Attach suitable lifting equipment to the lifting bolts on the iQMB pump.
10. If you have a direct mounted pumping system, continue at Step 11. If you have a booster frame mounted pumping system:
 - Remove the iQMB pump from the booster frame as described in the iQMB Booster Frame Connection Kits instruction manual
 - Continue at Step 12.
11. Disconnect the iQMB pump outlet from the flange adaptor on the iQDP pump inlet manifold: refer to the iQMB Booster Connection Kits instruction manual.
12. Fit the new pump as described in the iQMB Booster Connection Kits or the iQMB Booster Frame Connection Kits instruction manual. Note that you will not need to fit the inlet adaptor to the iQDP pump.
13. Move the iQ system back into its operating location and connect it to the vacuum and exhaust-extraction system: refer to Section 6.17.
14. Use the Pump Display Module to enter the serial number of the new iQMB pump: see Section 5.3.3.

6.19 Replace the iQDP pump with the iQMB pump connected to the process system (booster frame mounted combination pumping systems only)

If you want to replace the iQDP pump with the iQMB pump still fitted to the process system, use the following procedure.

1. Shut down the iQ system, as described in Section 5.6 and allow the pumps to cool.
2. Disconnect the braided RF earth (ground) wire from the inlet of the iQMB pump.
3. Remove the iQDP pump as described in the QMB/iQMB Booster Frame Connection Kits instruction manual.
4. Fit the new iQDP pump to the iQMB pump: refer to the QMB/iQMB Booster Frame Connection Kits instruction manual.
5. Use the Pump Display Module to enter the serial number of the new iQDP pump: see Section 5.3.3.

6.20 Zero the Gas Module flow transducers

The accuracy of the flow transducers in the Gas-Ballast and Gas System Modules may drift slightly and need to be 'zeroed' (that is, calibrated for zero gas flow) after a period of operation (usually several years).

You must zero the transducers with the electrical supply on, the iQ system switched off and your nitrogen supply off and disconnected from the Gas Module. This ensure that the transducers are correctly zeroed when there is no nitrogen flow (if you zero the transducers with the nitrogen supply connected, small nitrogen leaks through the solenoid-valves could affect the calibration).

Use the Setup/Service/Zero Sensors menu to start to zero the transducers, then use the Status menu to display the gas flows; the gas flow displayed will be zero when the transducers have been correctly zeroed. Note that it will take approximately 10 minutes to zero the transducers. If required, use the Status menu to view the time remaining before the sensors are fully zeroed.

6.21 Fault finding

6.21.1 Warning and alarm message fault finding

When a warning or alarm message is generated, you can display the message and (for some of the messages) two lines of text (the advisory message) which identify possible checks you can make to identify the cause of the fault and to rectify the fault.

The first line of a message specifies the fault condition (warning or alarm) and shows the error number. Error numbers are of the form PFF or PFFF, where:

- P or PP specifies the fault parameter associated with the alarm or warning: refer to Table 6-5.
- FF specifies the fault type type: refer to Table 6-6.

Table 6-2 shows all of the warning messages, the corresponding lines of advisory text (if any) and the meaning of the error/recommended actions. The warning messages are given in error number order in this table.

Table 6-3 shows all of the alarm messages, the corresponding lines of advisory text (if any) and the meaning of the error/recommended actions. The alarm messages are given in error number order in this table.

6.21.2 Service LED fault finding

Note: The service LED on a Module will also flash if the service button on the Module is pressed: refer to the instruction manual supplied with the Network Interface Module for more information.

Modules in the iQ system have a service LED which goes on whenever one of the following faults is detected by the module:

- A bad sensor reading was received (for example, the data is not in the expected range).
- A fault in the microprocessor.
- The analogue-to-digital convertor timed out (that is; the analogue-to-digital conversion did not finish in the expected time; there may be a fault in the convertor).

The LED will remain on as long as the fault condition is present. The locations of the service LEDs are as follows:

- Gas-Ballast and Gas System Modules: Figure 3-12, item 6.
- Pump Display Module: Figure 1-10, item 2.
- Sensor Monitoring Module: Figure 1-8, items 9 and 14.

6.21.3 Other fault finding

Fault messages will be shown on the Pump Display Module to identify that the action you have selected cannot be carried out. The messages which can be displayed and their meanings are shown in Table 6-4.

Warning message	Advisory message	Meaning/recommended action
WARNING 101		(a) there is a fault in the control module PCA, or (b) a module or sensor which should be fitted is not fitted or is disconnected, or (c) the emergency stop button has been pressed (or a safety sensor has operated or your external emergency stop switch has been operated) to shut down the iQ system, or (d) there has been a transient electrical supply failure (longer than the hold-up time of the iQ power supply), or (e) the wrong gas module is fitted for the current iQ configuration.
WARNING 113		There is a fault in the ADC (analogue-to-digital convertor) in the Control Module; the ADC must be replaced.
WARNING 209	SEE MANUAL	The electrical supply voltage is too low. Check the electrical supply and the connections to the iQ system and rectify as necessary.
WARNING 211	SEE MANUAL	The electrical supply voltage is too high. Check the electrical supply and the connections to the iQ system and rectify as necessary.
WARNING 309 QDP CURRENT LOW	OPEN CIRCUIT CHECK CONNECTION	The electrical current drawn by the iQDP pump is less than normal. Check that the electrical connections are correct and rectify as necessary. If the electrical connections are correct, a fuse in the Electrics Module may have failed or the gearbox coupling may have failed.
WARNING 311 QDP CURRENT HIGH	LEAK/DEBRIS SERVICE PUMP	The electrical current drawn by the iQDP pump is higher than normal. There may be a leak in the system or process debris in the pump, or the pump motor may have failed. Inspect the pipelines and service the pump.
WARNING 409 QDP POWER LOW	OPEN CIRCUIT CHECK CONNECTION	The electrical power consumption of the iQDP pump is less than normal. Check that the electrical connections are correct and rectify as necessary. If the electrical connections are correct, a fuse in the Electrics Module may have failed or the gearbox coupling may have failed.

Table 6-2 - Warning messages

Warning message	Advisory message	Meaning/recommended action
WARNING 411 QDP POWER HIGH	LEAK/DEBRIS SERVICE PUMP	The electrical power consumption of the iQDP pump is higher than normal. There may be a leak in the system or process debris in the pump, or the pump motor may have failed. Inspect the pipelines and service the pump. (This fault may occur if you have a 6 kW iQDP80 pump and you have not adjusted the setpoints correctly: refer to Section 5.3.2.)
	HIGH INLET PRESS N2 FLOW MAY DROP	The iQ system has been running for an extended period with a higher than normal inlet pressure. This may affect iQDP power consumption, but it should return to normal when the inlet pressure is reduced.
WARNING 412 QDP POWER HIGH	LEAK/DEBRIS SERVICE PUMP	Refer to the recommended actions for error number 411 in this table.
WARNING 509	SEE MANUAL	The iQDP motor thermistors are short circuited. Check the thermistor connections inside the iQDP pump motor terminal-box and check the connections between the iQDP pump and the Electrics Module.
WARNING 611	SEE MANUAL	There is a phase imbalance in the electrical supply to the iQDP pump. Check the electrical supply and the connections to the iQ system. If the electrical supply and connections are correct, the pump motor may be faulty.
WARNING 709 QMB CURRENT LOW	OPEN CIRCUIT CHECK CONNECTION	The electrical current drawn by the iQMB pump is lower than normal. Check that the electrical connections are correct and rectify as necessary. If the electrical connections are correct, a fuse in the Electrics Module may have failed or the gearbox coupling may have failed or the coupling-cover oil-level may be too low.
WARNING 711 QMB CURRENT HIGH	LEAK/DEBRIS SERVICE PUMP	The electrical current consumption of the iQMB pump is higher than normal. There may be a leak in the system or process debris in the pump, or the pump motor may have failed or the coupling-cover oil-level may be too low. Inspect the pipelines and service the pump.

Table 6-2 - Warning messages (continued)

Warning message	Advisory message	Meaning/recommended action
WARNING 809 QMB POWER LOW	OPEN CIRCUIT CHECK CONNECTION	The electrical power consumption of the iQMB pump is lower than normal. Check that the electrical connections are correct and rectify as necessary. If the electrical connections are correct, a fuse in the Electrics Module may have failed or the gearbox coupling may have failed or the coupling-cover oil-level may be too high.
WARNING 811 QMB POWER HIGH	LEAK/DEBRIS SERVICE PUMP	The electrical power consumption of the iQMB pump is higher than normal. There may be a leak in the system or process debris in the pump or the pump motor may have failed or the coupling-cover oil-level may be too high. Inspect the pipelines and service the pump.
	HIGH INLET PRESS N2 FLOW MAY DROP	The iQ system has been running for an extended period with a higher than normal inlet pressure. This may affect iQMB power consumption, but it should return to normal when the inlet pressure is reduced.
WARNING 812 QMB POWER HIGH	LEAK/DEBRIS SERVICE PUMP	Refer to the recommended actions for error number 811 in this table.
WARNING 909	SEE MANUAL	The iQMB motor thermistors are short circuited. Check the thermistor connections inside the iQMB pump motor terminal-box and check the connections between the iQMB pump and the Electrics Module.
WARNING 1011	SEE MANUAL	There is a phase imbalance in the electrical supply to the iQMB pump. Check the electrical supply and the connections to the iQ system. If the electrical supply and connections are correct, the pump motor may be faulty.
WARNING 1201		When started the, no electrical current was drawn by the iQDP pump. Check whether the pump motor is open circuit. If not, the current sensor may have failed.
WARNING 1401 SERVICE DUE (R)	xxxxx HRS RUN SINCE SERVICE	The iQ system has operated for xxxxx hours since it was last serviced. Service the iQ system.
WARNING 1601 SERVICE DUE (P)	xxxxx HRS RUN SINCE SERVICE	The iQ system has operated for xxxxx hours since it was last serviced. Service the iQ system.

Table 6-2 - Warning messages (continued)

Warning message	Advisory message	Meaning/recommended action
WARNING 1801 SERVICE DUE (P)	xxxxx CYCLES SINCE SERVICE	The iQ system has been operated for xxxxx process cycles since it was last serviced. Service the iQ system.
WARNING 2001 SERVICE DUE (C)	xxxxx CYCLES SINCE SERVICE	The iQ system has been operated for xxxxx switch-on/off cycles since it was last serviced. Service the system.
WARNING 3101		The Gas Module may be disconnected. If the wiring connections are correct the PCA may be faulty.
WARNING 3113		There is a fault in the ADC (analogue-to-digital convertor) in the Gas Module; the ADC must be replaced.
WARNING 3201		(a) the Gas Module flow transducers have drifted outside the valid range allowed for zeroing, or (b) you cannot zero the transducers because the nitrogen purge is switched on or the iQDP pump is on.
WARNING 3209 FINAL ST FLOW LO	PIPE BLOCKED SERVICE PUMP	The final stage gas flow is too low. The gas pipe to the shaft-seals may be blocked or a transducer may have failed.
	N2 SUPPLY OFF	The nitrogen supply is switched off or below the pressure specified in Section 2. Check and rectify as necessary.
	ADJUST REGULATOR INCREASE PRESS	The shaft-seals purge pressure is too low. Check that the nitrogen supply is as specified in Section 2 and that you have correctly adjusted the pressure: refer to Section 3.22. If you cannot correctly adjust the pressure, the regulator may be faulty.
	HIGH INLET PRESS N2 FLOW MAY DROP	The iQ system has been running for an extended period with a higher than normal inlet pressure. This may affect purge flow rates but they should return to normal when the inlet pressure is reduced.
	3/4 STAGE BLOCK SERVICE PUMP	The 3/4-interstage purge pipeline or restrictor may be blocked or the restrictor may be too small, or the variable restrictor may need adjustment.
WARNING 3210 FINAL ST FLOW LO	PIPE BLOCKED SERVICE PUMP	Refer to the recommended actions for error number 3209 in this table.

Table 6-2 - Warning messages (continued)

Warning message	Advisory message	Meaning/recommended action
WARNING 3211 FINAL ST FLOW HI	ADJUST REGULATOR REDUCE PRESSURE	Refer to the recommended actions for error number 4011 in this table.
	3/4 I/STAGE HIGH CHECK RESTRICTOR	The 3/4-interstage purge flow rate is too high. Check that the purge restrictor is fitted correctly and is the correct size. The purge variable restrictor may be used to reduce the flow rate.
	SS FLOW HIGH SERVICE PUMP	The shaft-seals purge flow rate is too high and the pump may need to be serviced.
WARNING 3212 FINAL ST FLOW HI	FLOW HIGH CHECK GAS MODULE	Refer to the recommended actions for error number 3211 in this table.
WARNING 3213		The final stage flow sensor is not fitted, or is disconnected or has failed. Check and rectify as necessary.
WARNING 3509 AUX FLOW LOW	N2 SUPPLY OFF	The nitrogen supply is switched off or below the pressure specified in Section 2. Check and rectify as necessary.
	ADJUST REGULATOR INCREASE PRESS	The shaft-seals purge pressure is too low. Check that the nitrogen supply is as specified in Section 2 and that you have correctly adjusted the pressure: refer to Section 3.22. If you cannot correctly adjust the pressure, the regulator may be faulty.
	HIGH INLET PRESS N2 FLOW MAY DROP	The iQ system has been running for an extended period with a higher than normal inlet pressure. This may affect purge flow rates but they should return to normal when the inlet pressure is reduced.
	2/3 STAGE BLOCK SERVICE PUMP	The 2/3-interstage purge pipeline or restrictor may be blocked or the restrictor may be too small or the variable restrictor may need adjustment.
	EXHAUST BLOCKED SERVICE PUMP	The pressure in the exhaust pipeline is too high. There may be process debris or condensation in the exhaust pipeline, exhaust-purge pipeline or restrictor, or a valve in the pipeline may be shut. You may have too many pumping systems connected to the exhaust pipeline.
	INLET PURGE BLOCK SERVICE PUMP	The inlet-purge pipeline or restrictor may be too small or be blocked.
WARNING 3510 AUX FLOW	PIPE BLOCKED SERVICE PUMP	Refer to the recommended actions for error number 3509 in this table.

Table 6-2 - Warning messages (continued)

Warning message	Advisory message	Meaning/recommended action
WARNING 3511 AUX FLOW HIGH	ADJUST REGULATOR REDUCE PRESSURE	Refer to the recommended actions for error number 4011 in this table.
	2/3 I/STAGE HIGH CHECK RESTRICTOR	The 2/3-interstage purge flow rate is too high. Check that the purge restrictor is fitted correctly and is of the correct size. The variable restrictor may be used to reduce this flow rate.
	EXH PURGE HIGH CHECK RESTRICTOR	The exhaust-purge flow rate is too high. Check that the purge restrictor is fitted correctly and is the correct size.
	INLET PURGE HIGH CHECK RESTRICTOR	The inlet-purge flow rate is too high. Check that the purge restrictor is fitted correctly and is the correct size.
WARNING 3512 AUX FLOW	FLOW HIGH CHECK Gas Module	Refer to the recommended actions for error number 3511 in this table.
WARNING 3513		The auxiliary flow sensor is not fitted, or is disconnected or has failed. Check and rectify as necessary.
WARNING 3911 EXHAUST PRESSURE	EXHAUST BLOCKED SERVICE PUMP	The pressure in the exhaust pipeline is too high. There may be process debris or condensation in the exhaust pipeline, purge line, or restrictor, or a valve in the pipeline may be shut. You may have too many pumping systems connected to the exhaust pipeline.
	EXH PURGE HIGH CHECK RESTRICTOR	The exhaust-purge flow rate is too high. Check that the purge restrictor is fitted correctly and is the correct size.
WARNING 3913		The exhaust pressure transducer is not fitted, or is disconnected or has failed. Check and rectify as necessary.
WARNING 4009 SS PURGE LOW	ADJUST REGULATOR INCREASE PRESSURE	The shaft-seals purge pressure is too low. Check that the nitrogen supply is as specified in Section 2 and that you have correctly adjusted the pressure: refer to Section 3.22. If you cannot correctly adjust the pressure, the regulator may be faulty.
WARNING 4010 SS PURGE LOW	ADJUST REGULATOR INCREASE PRESSURE	Refer to the recommended actions for error number 4009 in this table.
	N2 SUPPLY OFF	The nitrogen supply is switched off or below the pressure specified in Section 2. Check and rectify as necessary.

Table 6-2 - Warning messages (continued)

Warning message	Advisory message	Meaning/recommended action
WARNING 4011 SS PURGE HIGH	PRESSURE HIGH CHECK GAS MODULE	The shaft-seals purge pressure is too high. Check that you have correctly adjusted the pressure: refer to Section 3.22. If you cannot correctly adjust the pressure, the regulator may be faulty.
WARNING 4012 SS PURGE HIGH	ADJUST REGULATOR REDUCE PRESSURE	Refer to the recommended actions for error number 4011 in this table.
	HIGH INLET PRESS N2 FLOW MAY DROP	The iQ system has been running for an extended period with a higher than normal inlet pressure. This may affect the nitrogen pressure but it should return to normal when the inlet pressure is reduced.
WARNING 4013		The shaft-seals pressure transducer is not fitted, or is disconnected or has failed. Check and rectify as necessary.
WARNING 5101		The Sensor Monitoring Module may be disconnected. If the wiring connections are correct, the PCA may be faulty.
WARNING 5113		There is a fault in the ADC (analogue-to-digital convertor) in the Sensor Monitoring Module; the ADC must be replaced.
WARNING 5411 QMB MOTOR TEMP	CHECK COOLING WATER SUPPLY	Check that the cooling-water supply is correctly connected and is switched on. Check that there is no blockage in the cooling-water supply pipeline or the pump cooling system.
	MOTOR WATER LOW CHECK FILTER	The filter in the TCV manifold may be blocked with debris. Check the filter and clean as necessary.
WARNING 5413		Check that the iQMB pump-motor surface temperature sensor is fitted and is correctly connected. If the sensor is correctly fitted and connected, either the temperature of the pump-motor is above the temperature measurement range of the iQ system, or the sensor may have failed. Check the operation of the sensor and replace it if it has failed.
WARNING 5511 QDP MOTOR TEMP	CHECK COOLING WATER SUPPLY	Check that the cooling-water supply is correctly connected and is switched on. Check that there is no blockage in the cooling-water supply pipeline or the pump cooling system.
	MOTOR WATER LOW CHECK FILTER	The filter in the TCV manifold may be blocked with debris. Check the filter and clean as necessary.

Table 6-2 - Warning messages (continued)

Warning message	Advisory message	Meaning/recommended action
WARNING 5513		The iQMB pump-motor surface temperature sensor is not fitted, or is disconnected or has failed: refer to the recommended actions for warning 5413.
WARNING 5609 EXHAUST TEMP LOW	EXHAUST TEMP LOW CHECK EXHAUST	The temperature of the exhaust is too low for the process. Check that the operating temperature of the iQDP pump is correctly adjusted: refer to Section 3.22. Check that any exhaust lagging or heaters are operating correctly. Check that the exhaust temperature sensor is not covered in deposition.
	HIGH INLET PRESS N2 FLOW MAY DROP	The iQ system has been running for an extended period with a higher than normal inlet pressure. This may affect exhaust temperature, but it should return to normal when the inlet pressure is reduced.
	ADJUST TCV	Refer to the recommended actions for error number 5709 in this table.
WARNING 5613		You have configured the iQ to have an exhaust temperature sensor fitted, but the sensor is not fitted, or is disconnected or has failed, or the exhaust temperature is too high. Check that the temperature sensor is fitted and is correctly connected. If the sensor is correctly fitted and connected, either the exhaust temperature is above the temperature measurement range of the iQ system, or the sensor may have failed. Check the operation of the sensor and replace it if it has failed.
WARNING 5709 QDP TEMP LOW	TCV SET LOW ADJUST TCV	The operating temperature of the iQDP pump is too low: check that the operating temperature of the iQDP pump is correctly adjusted: refer to Section 3.22.
WARNING 5711 QDP TEMP HIGH	TCV SET HIGH ADJUST TCV	The operating temperature of the iQDP pump is too high: check that the operating temperature of the iQDP pump is correctly adjusted: refer to Section 3.22. If the TCV is set correctly, the TCV may have failed or there may be process debris in the pump or the pump may be damaged.
	CHECK COOLING WATER SUPPLY	Check that the cooling-water supply is correctly connected and is switched on. Check that there is no blockage in the cooling-water supply pipeline or the pump cooling system.

Table 6-2 - Warning messages (continued)

Warning message	Advisory message	Meaning/recommended action
WARNING 5713		The iQDP pump-body temperature sensor is not fitted, or is disconnected or has failed. Check that the temperature sensor is fitted and is correctly connected. If the sensor is correctly fitted and connected, either the pump-body temperature is above the temperature measurement range of the iQ system, or the sensor may have failed. Check the operation of the sensor and replace it if it has failed.
WARNING 5801 QDP OIL LOW	LOW OIL LEVEL ADD OIL	The level of oil in the iQDP pump is too low. If the oil-level has fallen slowly, add more oil (refer to Section 6.7). If there has been a rapid loss of oil, there may be a fault in the pump or the shaft-seals purge pressure may be too high or too low.
WARNING 5901 QMB OIL LOW	LOW OIL LEVEL ADD OIL	The level of oil in the iQMB pump is too low. If the oil-level has fallen slowly, add more oil (refer to Section 6.5). If there has been a rapid loss of oil, there may be a fault in the pump.
WARNING 6001 WATER FLOW LOW	CHECK COOLING WATER SUPPLY	Check that the cooling-water supply is correctly connected and is switched on. Check that there is no blockage in the cooling-water supply pipeline or the pump cooling system.
WARNING 11101		There is a fault in the NIM (Network Interface Module): refer to the instruction manual supplied with the NIM.
WARNING 12101		There is a fault in the Tool Interface Card in the iQ Interface Module. Refer to the instruction manual supplied with the iQ Interface Module.
WARNING 15101		There is a fault in the Auxiliary Interface Card in the iQ Interface Module. Refer to the instruction manual supplied with the iQ Interface Module.
WARNING 15201		The gate valve connected to the iQ Interface Module has failed to close. Refer to the instruction manuals supplied with the iQ Interface Module and the gate valve.
WARNING 15301		The gate valve connected to the iQ Interface Module has failed to open. Refer to the instruction manuals supplied with the iQ Interface Module and the gate valve.

Table 6-2 - Warning messages (continued)

Alarm message	Advisory message	Meaning/recommended action
ALARM 101 EMS PRESSED		The emergency stop switch has been pressed or a safety sensor connected to the emergency stop circuit has operated (or your remote emergency off circuit has operated) to shut down the iQ system. Note that the message will remain on the display until you restart the pumping system.
ALARM 101		Refer to the recommended actions for error number 101: see Table 6-2.
ALARM 210		Refer to the recommended actions for error number 209: see Table 6-2.
ALARM 212		Refer to the recommended actions for error number 211: see Table 6-2.
ALARM 310 QDP CURRENT LOW	OPEN CIRCUIT CHECK CONNECTION	Refer to the recommended actions for error number 309: see Table 6-2.
ALARM 312 QDP CURRENT HIGH	LEAK/DEBRIS SERVICE PUMP	Refer to the recommended actions for error number 311: see Table 6-2.
ALARM 410 QDP POWER LOW	OPEN CIRCUIT CHECK CONNECTION	Refer to the recommended actions for error number 409: see Table 6-2.
ALARM 412 QDP POWER HIGH	LEAK/DEBRIS SERVICE PUMP	Refer to the recommended actions for error number 411: see Table 6-2.
ALARM 512		The pump-motor has tripped out because the motor windings are too hot: either the cooling-system has failed or the motor overloaded. Either of these faults should have been identified before shut-down, so either there are two separate faults (for example, cooling-water supply failure and thermocouple circuit failure) or the thermistor circuit has failed: contact your supplier or BOC Edwards.
ALARM 612		Refer to the recommended actions for error number 611: see Table 6-2.
ALARM 710 QMB CURRENT LOW	OPEN CIRCUIT CHECK CONNECTION	Refer to the recommended actions for error number 709: see Table 6-2.
ALARM 712 QMB CURRENT HIGH	LEAK/DEBRIS SERVICE PUMP	Refer to the recommended actions for error number 711: see Table 6-2.
ALARM 810 QMB POWER LOW	OPEN CIRCUIT CHECK CONNECTION	Refer to the recommended actions for error number 809: see Table 6-2.
ALARM 812 QMB POWER HIGH	LEAK/DEBRIS SERVICE PUMP	Refer to the recommended actions for error number 811: see Table 6-2.

Table 6-3 - Alarm messages

Alarm message	Advisory message	Meaning/recommended action
ALARM 912		Refer to the recommended actions for error number 512 in this table.
ALARM 1012		Refer to the recommended actions for error number 1011: see Table 6-2.
ALARM 1101		(a) the electrical supply is not connected to the iQDP pump-motor, or (b) the iQDP pump has started, but has then immediately stopped again, because the phase sequence of the electrical supply to the pump is incorrect: reverse two of the phases in the electrical supply connector: refer to Section 3.19, or (c) the incorrect Gas Module is fitted: check that you have configured the iQ system for the correct Gas Module (refer to Section 5.3).
ALARM 3912 EXHAUST PRESSURE	EXHAUST BLOCKED SERVICE PUMP	Refer to the recommended actions for error number 3911: see Table 6-2.
ALARM 5412 QMB MOTOR TEMP	MOTOR WATER LOW CHECK FILTER	Refer to the recommended actions for error number 5411: see Table 6-2.
ALARM 5512 QDP MOTOR TEMP	MOTOR WATER LOW CHECK FILTER	Refer to the recommended actions for error number 5511: see Table 6-2.
ALARM 5610 EXHAUST TEMP LOW	EXHAUST TEMP LOW CHECK EXHAUST	Refer to the recommended actions for error number 5609: see Table 6-2.
ALARM 5710 QDP TEMP LOW	TCV SET LOW ADJUST TCV	Refer to the recommended actions for error number 5709: see Table 6-2.
ALARM 5712 QDP TEMP HIGH	TCV SET HIGH ADJUST TCV	Refer to the recommended actions for error number 5711: see Table 6-2.

Table 6-3 - Alarm messages (continued)

Message	Meaning
CONTROL failed Press CANCEL	You have requested that the Pump Display Module takes control of the iQ system, but the attempt to take control has failed. Press the CANCEL button to return to normal display.
CONTROL LOCKED Press CANCEL	You have requested that the Pump Display Module takes control of the iQ system, but another module still has control. Press the CANCEL button to return to normal display, release control from the module which currently has control and then try again.
CONTROL REMOTE Press CANCEL	You have requested some action, but the Pump Display Module does not have control of the iQ system. Press the CANCEL button, take control and then try again.
PUMP failed to respond (CANCEL)	(a) You have requested that the iQ system is switched on or off, but the pump(s) has failed to start or stop: press the CANCEL button to cancel the request, identify and rectify the cause for the failure of the pump(s) to start or stop, then try again. (b) You have tried to open or close the gate valve (if fitted), but the valve has failed to respond. Identify and rectify the cause for the failure of the valve to open or close, then try again. (c) A value (for example, a setpoint) has been requested from the iQ system, but the iQ system has not responded. (d) You have pressed ENTER when an unused sensor is shown on the Setup/Service/Configuration menu. (e) The emergency stop switch has been pressed and released: restart the pumping system.
PUMP RUNNING Press CANCEL	You have requested that the iQ system is switched on, but it is already on. Press the CANCEL button to return to normal display.
PUMP STOPPED Press CANCEL	You have requested that the iQ system is switched off, but it is already off. Press the CANCEL button to return to normal display.
EDWARDS iQ DISPLAY MODULE	If this message is displayed when the iQ system is switched on and the display does not change to normal display, this means that the Pump Display Module cannot correctly communicate with the iQ system.
Config update failed (CANCEL)	The iQ system has been requested to change a setpoint to a value, but the setpoint value returned is different from that sent to the iQ. Press CANCEL and try again.
None (the display is blank)	One or both of fuses FS6 and FS8 may have tripped. Switch off the electrical supply to the iQ system, then switch it on again to reset the fuse(s).

Table 6-4 - Fault messages

Parameter †	Source/cause of error
1	iQ system status
2	Electrical supply voltage
3	iQDP pump current consumption
4	iQDP pump power consumption
5	iQDP pump-motor thermistors
6	Phase imbalance in iQDP pump current consumption
7	iQMB pump current consumption
8	iQMB pump power consumption
9	iQMB pump-motor thermistors
10	Phase imbalance in iQMB pump current consumption
11	iQDP pump status
12	iQMB pump status
14	Total run hours (since last service)
16	Total run hours (on process, since last service)
18	Process cycles (since last service)
20	Switch-on/off cycles (since last service)
31	Gas module status
32	Gas Module flow transducers: final stage purge flow
35	Gas Module flow transducers: auxiliary purge flow
39	Exhaust pressure sensor
40	Shaft-seals purge pressure transducer
51	Sensor Monitoring Module status
54	iQMB pump-motor surface temperature sensor
55	iQDP pump-motor surface temperature sensor
56	iQ exhaust temperature sensor *
57	iQDP pump-body thermocouple
58	iQDP pump oil-level monitor
59	iQMB pump oil-level monitor
60	iQ water flow-switch *
111	Network Interface Module status *
121	Tool Interface Card status *
151	Auxiliary Interface Card status *
152	Gate valve closed status *
153	Gate valve open status *

† First digit of a three-digit error number, or first two digits of a four-digit error number.

* Optional accessory.

Table 6-5 - Fault parameters

7 STORAGE AND DISPOSAL

7.1 Storage

CAUTION

Drain the cooling-water from the pumping system, if you will transport or store it in conditions where the cooling-water could freeze. If you do not, cooling water may freeze in the pumping system and damage the pump(s).

If you will transport or store the pumping system in conditions where the cooling-water could freeze (for example, if you transport the pump as air freight), you must ensure that all cooling-water is drained from the pumping system.

Use the following procedure :

1. Remove the cooling-water connectors from the pump, or attach an open pair of quick-connector halves to the connectors on the pump.
2. Blow compressed air through the cooling-water inlet, to force any water out of the cooling system.

Store the iQ system as follows :

1. If applicable, ensure that the pumps have been shut down as described in Section 5.10 and disconnect all services, process and exhaust connections.
2. Fit blanking-plates to all vacuum inlets and exhaust outlets. Place protective covers over the iQ services connection points.
3. Store the iQ system in clean dry conditions until required.
4. When required for use, prepare and install the iQ system as described in Section 3 of this manual.

7.2 Disposal

Dispose of the iQ system and any components safely in accordance with all local and national safety and environmental requirements.

Take particular care with the following :

- Fluoroelastomers which may have decomposed as the result of being subjected to high temperatures.
- Components which have been contaminated with dangerous process substances.

8 SERVICE, SPARES AND ACCESSORIES

8.1 Introduction

BOC Edwards products and spares are available from BOC Edwards companies in Belgium, Brazil, China, France, Germany, Israel, Italy, Japan, Korea, Singapore, United Kingdom, U.S.A and a world-wide network of distributors. The majority of these centres employ Service Engineers who have undergone comprehensive BOC Edwards training courses.

Order spare parts and accessories from your nearest BOC Edwards company or distributor. When you order, please state for each part required:

- Model and Item Number of your equipment
- Serial number (if any)
- Item Number and description of the part.

8.2 Service

BOC Edwards products are supported by a world-wide network of BOC Edwards Service Centres. Each Service Centre offers a wide range of options including: equipment decontamination; service exchange; repair; rebuild and testing to factory specifications. Equipment which has been serviced, repaired or rebuilt is returned with a full warranty.

Your local Service Centre can also provide BOC Edwards engineers to support on-site maintenance, service or repair of your equipment.

For more information about service options, contact your nearest Service Centre or other BOC Edwards company.

8.3 Spares

8.3.1 Pumps

Note: Refer to Section 8.4.2 for Motor Ancillaries Kits, to convert QMB pumps to iQMB pumps.

Spare	Item Number
iQDP40 dry pump	A532-40-905
iQDP80 dry pump	A532-80-905
QMB250F mechanical booster pump, 50 Hz	A301-85-905
QMB250F mechanical booster pump, 60 Hz	A301-86-905
QMB500F mechanical booster pump, 50 Hz	A302-85-905
QMB500F mechanical booster pump, 60 Hz	A302-86-905
QMB1200F mechanical booster pump, 50 Hz	A305-85-905
QMB1200F mechanical booster pump, 60 Hz	A305-86-905

8.3.2 Other spares

Spare	Item Number
iQDP pump routine maintenance kit	A526-40-820
Exhaust-silencer servicing kit	A386-11-820
Exhaust check-valve servicing kit	A440-03-820
Exhaust-silencer	A528-19-000
Terminator plug	A532-20-050
iQDP pump coolant	H128-10-002
End-cover 'O' ring (iQMB250F and iQMB500F)	H021-22-091

8.3.3 Greases and oils

Spare	Item Number
Fomblin RT15 grease (100 g)	H113-50-003
Fomblin Y25 oil (1 kg)	H113-12-019
Drynert 25/6 oil (1 kg)	H113-12-021
Drynert 25/6 oil (5 kg)	H113-12-025
Fomblin YVAC 16/6 fluid (1kg)	H113-06-019
Fomblin YVAC 16/6 fluid (5kg)	H113-06-020
Krytox 1514 oil (1kg)	H113-08-018
Krytox 1514 oil (5kg)	H113-08-020
Krytox 1525 oil (1 kg)	H113-09-018
Krytox 1525 oil (5 kg)	H113-09-020

8.4 Accessories

8.4.1 Gas modules

You must fit a Gas Module to the iQ pumping system. Use the type of Gas Module most suitable for your application: refer to Section 1.5 for a description of the Gas Modules.

Accessory	Item Number
iQDP Shaft-Seals Purge Module	A528-57-000
iQDP Gas-Ballast Module	A528-58-000
iQDP Gas System Module Series 2	A532-59-000

8.4.2 iQMB Motor Ancillaries Kits

These kits allow you to convert a QMB mechanical booster pump to an iQMB pump.

Accessory	Item Number
iQMB250/500F Motor Ancillaries Kit	A532-25-033
iQMB1200F Motor Ancillaries Kit	A532-12-033

8.4.3 iQMB Booster Connection Kits

The iQMB Booster Connection Kit allows you to fit an iQMB mechanical booster pump directly on the inlet of the iQ system.

Accessory	Item Number
iQMB Booster Connection Kit for iQDP40/iQMB250F (HEM)	A532-30-000
iQMB Booster Connection Kit for iQDP40/iQMB250F (VEM)	A532-31-000 *
iQMB Booster Connection Kit for iQDP40/iQMB500F (HEM)	A532-32-000
iQMB Booster Connection Kit for iQDP80/iQMB250F (HEM)	A532-33-000
iQMB Booster Connection Kit for iQDP80/iQMB500F (HEM)	A532-34-000

* With this kit, the Electrics Module is mounted vertically on the iQDP pump frame, so that you can use the iQ combination system to replace an existing QDP installation. With other (HEM) kits, the Electrics Module is mounted horizontally on the iQDP pump frame.

8.4.4 iQ Acoustic Enclosures

When fitted to an iQ system, an Acoustic Enclosure reduces noise from the iQDP pump.

Accessory	Item Number
iQDP Acoustic Enclosure for iQ40	A532-01-000
iQDP Acoustic Enclosure for iQ80	A532-03-000

8.4.5 iQMB Booster Frames

Note: The accessories listed in Sections 8.4.6 and 8.4.7 are designed to be used together with the iQMB Booster Frame described in this section.

The iQMB Booster Frame supports the iQMB pump and allows you to leave the iQMB pump installed in the vacuum system while you install or remove the iQ dry pump.

Accessory	Item Number
iQMB Booster Frame for iQDP40/iQMB250F	A528-37-000
iQMB Booster Frame for iQDP40/iQMB500F, iQDP80/iQMB250F and iQDP80/iQMB500F	A528-38-000
iQMB Booster Frame for iQDP80/iQMB1200F	A528-39-000

8.4.6 QMB Booster Frame Connection Kits

These kits enable an iQMB pump fitted in a Booster Frame to be mounted onto an iQ system. Each kit contains a sub-frame to support the iQMB pump before you install the iQ system, a flange adaptor (if necessary) and cooling-water pipes and connections to connect the iQMB pump cooling-system to the iQDP pump cooling-system.

Accessory	Item Number
iQMB Booster Frame Connection Kit for QDP40/QMB250F	A528-65-000
iQMB Booster Frame Connection Kit for QDP40/QMB500F	A528-66-000
iQMB Booster Frame Connection Kit for QDP80/QMB250F	A528-67-000
iQMB Booster Frame Connection Kit for QDP80/QMB500F	A528-68-000
iQMB Booster Frame Connection Kit for QDP80/QMB1200F	A528-69-000
iQMB In-Line Booster Frame Connection Kit for QDP80/QMB1200F	A532-69-000

8.4.7 iQMB Booster Frame Acoustic Enclosures

When fitted to an iQMB Booster Frame, an Acoustic Enclosure reduces noise from the pumps.

Accessory	Item Number
iQMB Booster Frame Acoustic Enclosure for iQDP40/iQMB250F	A532-70-000
iQMB Booster Frame Acoustic Enclosure for iQDP40/iQMB500F	A532-71-000
iQMB Booster Frame Acoustic Enclosure for iQDP80/iQMB250F	A532-72-000
iQMB Booster Frame Acoustic Enclosure for iQDP80/iQMB500F	A532-73-000
iQMB Booster Frame Acoustic Enclosure for iQDP80/iQMB1200F	A532-74-000

8.4.8 OLM500 Oil-Level Monitor

The OLM500 oil-level monitor can be fitted to either or both of the iQDP and iQMB pumps to monitor the pump oil-level(s). If fitted, the sensor monitoring module monitors the outputs of the oil-level monitor and generates a warning if the oil-level of the pump(s) is too low.

Accessory	Item Number
OLM500 Oil-Level Monitor	A504-34-000

8.4.9 iQ Exhaust Temperature Sensor

The Exhaust Temperature Sensor monitors the temperature in the exhaust outlet of the iQ system. If fitted, the outputs of the Exhaust Temperature Sensor are monitored by the sensor monitoring module. If required, you can configure the iQ system to generate a warning if the exhaust temperature is too low or too high.

Accessory	Item Number
iQ Exhaust Temperature Sensor	A532-07-000

8.4.10 iQ Pump Display Module and extension cables

Note: If you do not have a Pump Display Module, you must install an Interface Module and/or the iQ Single Pumpset Monitor: see Sections 8.4.12 and 8.4.13.

The Pump Display Module enables you to manually operate the iQ system and to display the status of the iQ system. Use an extension cable to allow you to use the Pump Display Module further away from the iQ system.

Accessory	Item Number
iQ Pump Display Module	D372-09-000
Extension cable (display/interface), 3 m	D372-07-591
Extension cable (display/interface), 5 m	D372-07-592
Extension cable (display/interface), 10 m	D372-07-595
Extension cable (display/interface), 15 m	D372-07-596
Extension cable (display/interface), 25 m	D372-07-597

8.4.11 iQ Water Flow-Switch

When fitted, the Water Flow-Switch monitors the flow of cooling-water through the iQ system and generates a warning if the flow rate is too low.

Accessory	Item Number
iQ Water Flow-Switch	A532-49-000

8.4.12 iQ Interface Modules

The iQ Interface Module can be fitted with one or more of the following cards:

- Tool Interface Card.
- Auxiliary Interface Card.

The Tool Interface Card allows you to control and monitor the status of the iQ system through your process tool or other control equipment. The Tool Interface Card has a setpoints store. The setpoints store can be preset to contain sensor setpoints suitable for a particular process or application (that is, the combination of the iQ system configuration, process chemistry and user's production pattern). If you have a Tool Interface Card fitted, you can use the application recipe at any time (instead of the default setpoints in the iQ system).

The Auxiliary Interface Card allows you to connect other devices (such as inlet and outlet isolation-valves) to the iQ system.

Contact your supplier or BOC Edwards if you want to order iQ Interface Modules.

8.4.13 iQ PC Interface Kits

The iQ PC Interface Kit allows you to directly connect the iQ system to a laptop PC or to a desktop PC. The Kit is supplied with all necessary cables and with the iQ Single Pumpset Monitor software.

Accessory	Item Number
Desktop PC Interface Kit	D372-18-100
Laptop PC Interface Kit (USA)	D372-18-200
Laptop PC Interface Kit (Europe)	D372-18-300
Laptop PC Interface Kit (UK)	D372-18-400
Laptop PC Interface Kit (Japan)	D372-18-500

8.4.14 iQ Central Monitoring System

The iQ Central Monitoring System allows you to network together all of the iQ systems in your installation, and to use a PC to centrally monitor the iQ systems.

Contact your supplier or BOC Edwards if you want to network your iQ systems.

Return of BOC Edwards Equipment - Procedure

INTRODUCTION

Before returning your equipment, you must warn BOC Edwards if substances you used (and produced) in the equipment can be hazardous. This information is fundamental to the safety of our Service Centre employees and will determine the procedures employed to service your equipment.

Complete the Declaration (HS2) and send it to BOC Edwards before you dispatch the equipment. It is important to note that this declaration is for BOC Edwards internal use only, and has no relationship to local, national or international transportation safety or environmental requirements. As the person offering the equipment for shipment, it is your responsibility to ensure compliance with applicable laws.

GUIDELINES

- Equipment is '**uncontaminated**' if it has not been used, or if it has only been used with substances that are not hazardous. Your equipment is '**contaminated**' if it has been used with any substances classified as hazardous under EU Directive 67/548/EEC (as amended) or OSHA Occupational Safety (29 CFR 1910).
- If your equipment has been used with radioactive substances, biological or infectious agents, mercury, polychlorinated biphenyls (PCB's), dioxins or sodium azide, you must decontaminate it before you return it to BOC Edwards. You must send independent proof of decontamination (for example a certificate of analysis) to BOC Edwards with the Declaration (HS2). Phone BOC Edwards for advice.
- If your equipment is contaminated, you must either:
 - Remove all traces of contamination (to the satisfaction of laws governing the transportation of dangerous/hazardous substances).
 - Or, properly classify the hazard, mark, manifest and ship the equipment in accordance with applicable laws governing the shipment of hazardous materials.

Note: Some contaminated equipment may not be suitable for airfreight.

PROCEDURE

1. Contact BOC Edwards and obtain a Return Authorisation Number for your equipment.
2. Complete the Return of BOC Edwards Equipment - Declaration (HS2).
3. If the equipment is contaminated, you must contact your transporter to ensure that you properly classify the hazard, mark, manifest and ship the equipment, in accordance with applicable laws governing the shipment of contaminated/hazardous materials. As the person offering the equipment for shipment, it is your responsibility to ensure compliance with applicable law. **Note: Equipment contaminated with some hazardous materials, such as semiconductor by-products, may not be suitable for airfreight - contact your transporter for advice.**
4. Remove all traces of hazardous gases: pass an inert gas through the equipment and any accessories that will be returned to BOC Edwards. Where possible, drain all fluids and lubricants from the equipment and its accessories.
5. Seal up all of the equipment's inlets and outlets (including those where accessories were attached) with blanking flanges or, for uncontaminated product, with heavy gauge tape.
6. Seal equipment in a thick polythene/polyethylene bag or sheet.
7. If the equipment is large, strap the equipment and its accessories to a wooden pallet. If the equipment is too small to be strapped to a pallet, pack it in a suitable strong box.
8. Fax or post a copy of the Declaration (HS2) to BOC Edwards. The Declaration must arrive before the equipment.
9. Give a copy of the Declaration (HS2) to the transporter. You must tell your transporter if the equipment is contaminated.
10. Seal the original Declaration in a suitable envelope: attach the envelope securely to the outside of the equipment package, in a clear weatherproof bag.

WRITE YOUR RETURN AUTHORISATION NUMBER CLEARLY ON THE OUTSIDE OF THE ENVELOPE OR ON THE OUTSIDE OF THE EQUIPMENT PACKAGE.

Return of BOC Edwards Equipment - Declaration

Return Authorisation Number: _____

You must:

- Know about all of the substances which have been used and produced in the equipment before you complete this Declaration
- Read the Return of BOC Edwards Equipment - Procedure (HS1) before you complete this Declaration
- Contact BOC Edwards to obtain a Return Authorisation Number and to obtain advice if you have any questions
- Send this form to BOC Edwards before you return your equipment

SECTION 1: EQUIPMENT

Equipment/System Name _____

Part Number _____

Serial Number _____

Has the equipment been used, tested or operated ?

YES Go to Section 2 NO Go to Section 4

IF APPLICABLE:

Tool Reference Number _____

Process _____

Failure Date _____

Serial Number of Replacement Equipment _____

SECTION 2: SUBSTANCES IN CONTACT WITH THE EQUIPMENT

Are any substances used or produced in the equipment:

- Radioactive, biological or infectious agents, mercury, poly chlorinated biphenyls (PCBs), dioxins or sodium azide? (if YES, see Note 1) YES NO
- Hazardous to human health and safety? YES NO

Note 1 : BOC Edwards will not accept delivery of any equipment that is contaminated with radioactive substances, biological/infectious agents, mercury, PCB's, dioxins or sodium azide, unless you:

- Decontaminate the equipment
- Provide proof of decontamination

YOU MUST CONTACT BOC EDWARDS FOR ADVICE BEFORE YOU RETURN SUCH EQUIPMENT

SECTION 3: LIST OF SUBSTANCES IN CONTACT WITH THE EQUIPMENT

Substance name	Chemical Symbol	Precautions required (for example, use protective gloves, etc.)	Action required after a spill, leak or exposure

SECTION 4: RETURN INFORMATION

Reason for return and symptoms of malfunction _____

- If you have a warranty claim:
- who did you buy the equipment from ? _____
 - give the supplier's invoice number _____

SECTION 5: DECLARATION

Print your name: _____ Print your job title: _____

Print your organisation: _____

Print your address: _____

Telephone number: _____ Date of equipment delivery: _____

I have made reasonable enquiry and I have supplied accurate information in this Declaration. I have not withheld any information, and I have followed the Return of BOC Edwards Equipment - Procedure (HS1).

Note: Please print out this form, sign it and return the signed form as hard copy.

Signed: _____ Date _____