

Chemtech Scientific provides access to this content as a courtesy.  
 We do not own the content contained in this document.  
 All rights and credit go directly to its rightful owners.  
[www.chemtechsci.com](http://www.chemtechsci.com)  
 Call us at: 484-424-9415

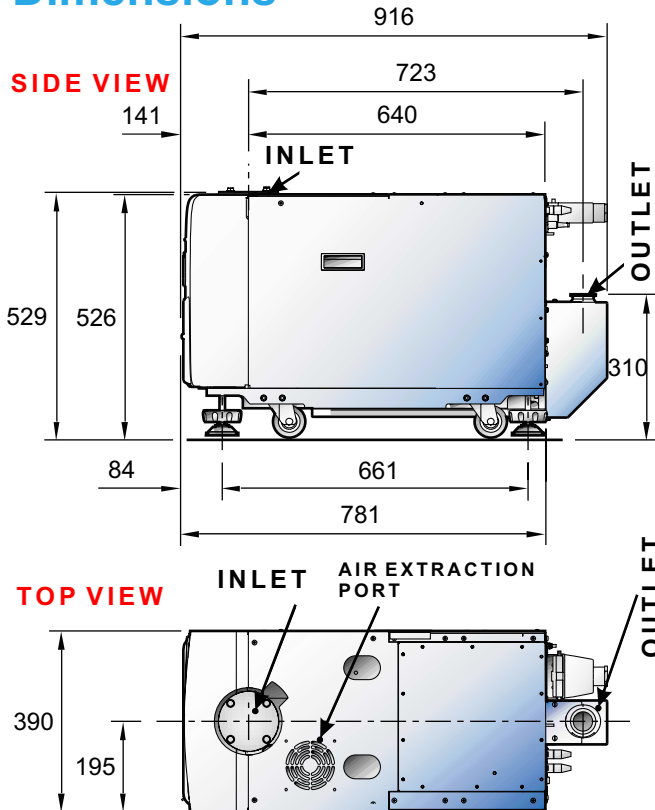

## Edwards iL70N Dimensions



## SPECIFICATIONS

		60 Hz	50 Hz
<b>Peak Speed</b>	<b>cfm</b>	<b>49</b>	<b>41</b>
	<b>M<sup>3</sup>h<sup>-1</sup></b>	84	70
	<b>1 min<sup>-1</sup></b>	1400	1166
<b>Ultimate Vacuum (with shaft seal purge)</b>	<b>torr</b>	<b>2.3X10<sup>-2</sup></b>	<b>3.8X10<sup>-2</sup></b>
	<b>mbar</b>	3X10 <sup>-2</sup>	5X10 <sup>-2</sup>
	<b>Pa</b>	3	5
<b>Typical Shaft Seal nitrogen flow</b>	<b>slm</b>	4	4
<b>Inlet Connection</b>		ISO63	
<b>Outlet Connection</b>		NW40	
<b>Typical cooling water flow at 15psi drop</b>	<b>1 h<sup>-1</sup></b>	90	
	<b>1 min<sup>-1</sup></b>	1.5	
<b>Weight</b>	<b>kg/lbs.</b>	230/506	
<b>Power input</b>	<b>kW</b>	1.5	1.3
<b>Rated motor</b>	<b>kW</b>	2.2	1.8
<b>Oil Capacity</b>	<b>liter</b>	0.75	

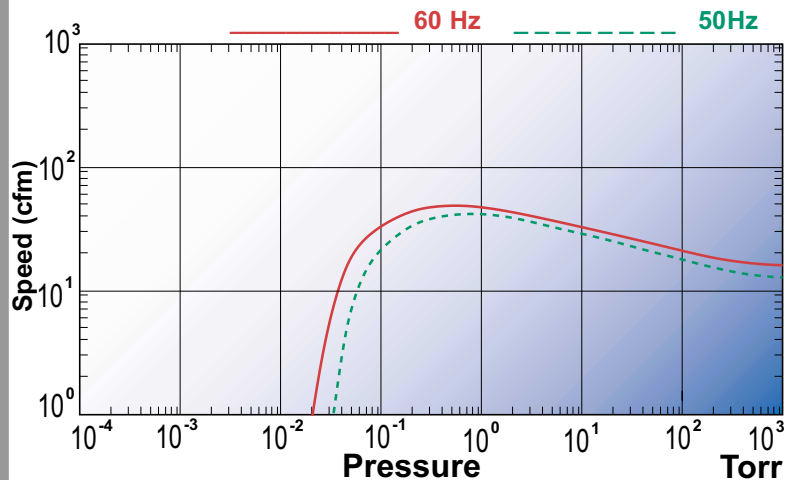

iL70N Pumping Speed Curve

**90 DAY WARRANTY  
ON ALL PARTS & LABOR**