

Chemtech Scientific provides access to this content as a courtesy.
 We do not own the content contained in this document.
 All rights and credit go directly to its rightful owners.
www.chemtechsci.com
 Call us at: 484-424-9415

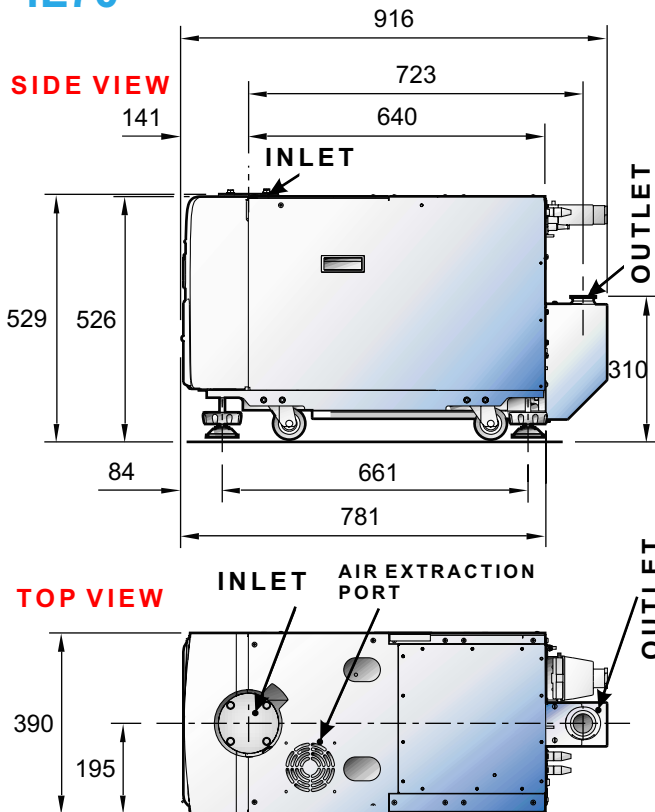

Dimensions iL70



SPECIFICATIONS

		60 Hz	50 Hz
Peak Speed	cfm	49	41
	M³h⁻¹	84	70
	1 min⁻¹	1400	1166
Ultimate Vacuum (with shaft seal purge)	torr	2.3X10⁻²	3.8X10⁻²
	mbar	3X10 ⁻²	5X10 ⁻²
	Pa	3	5
Typical Shaft Seal nitrogen flow	slm	0	0
Inlet Connection		ISO63	
Outlet Connection		NW40	
Typical cooling water flow at 15psi drop	1 h⁻¹	90	
	1 min⁻¹	1.5	
Weight	kg/lbs.	230/506	
Power input	kW	1.5	1.3
Rated motor	kW	2.2	1.8
Oil Capacity	liter	0.75	

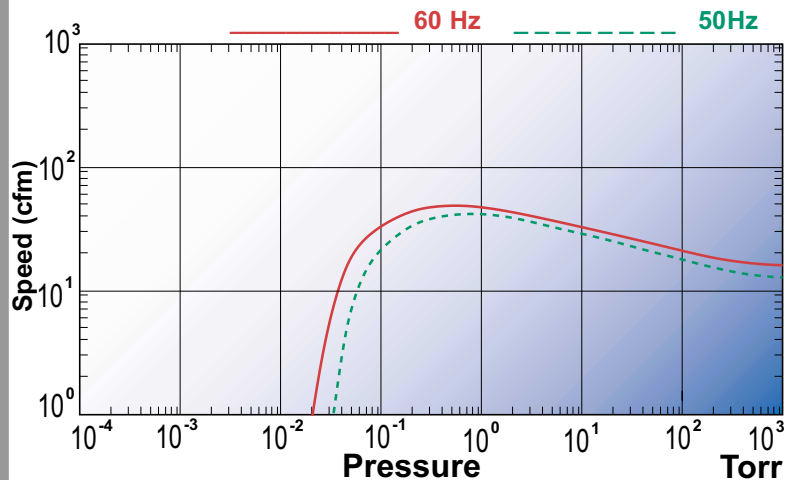

iL70 Pumping Speed Curve

**90 DAY WARRANTY
ON ALL PARTS & LABOR**