

Instruction Manual

iQ Interface Module



Safety during maintenance

Add the following warning to the start of Section 5 (Maintenance):

WARNING

If you need to open the iQ Interface Module for maintenance, support the inner module before you remove its retaining screws. If you do not, the inner module will fall and may injure you or be damaged.

iQ Interface Module - Item Number A528-44-404

1 Introduction

This Amendment describes the details of this iQ Interface Module

2 Cards fitted

The following Interface Card is fitted in this iQ Interface Module:

- AIC (Auxiliary Interface Card).

3 Connectors

The connectors in Table A1 are fitted to the interface connector panel on this iQ Interface Module:

Connector name/number	Connector type	Figure A1 reference
Tool	CPC 17/16-M	1
MCM	CPC 17/16-M	2
Gate valve	CPC 13/9-M	3
Remote EMS	9-way D.-conn.-F	4

Table A1 - Connector types

Use of connector pins

The signals available on the connectors are shown in Tables A2 to A5. Refer to the appropriate sections of this instruction manual for electrical data for the signals available on the Tool Interface Card and Auxiliary Interface Card connectors and for information on the use of the signals.

Pin numbers	Signal	Destination/ Source
1 and 2	Loadlock pump on 24 V a.c./d.c. control input	AIC, CH8 PL10
3 and 4	Loadlock pump running volt-free status output	AIC, CH6 PL7
7 and 8	Loadlock pump not in warning volt-free status output	AIC, CH5 PL7
9 and 10	Loadlock pump not in alarm volt-free status output	AIC, CH4 PL8

Table A2 - Tool connector signals

Pin numbers	Signal	Destination/ Source
3 and 4	Loadlock pump running volt-free control input	AIC, CH7 PL14
5 and 6	Loadlock pump on volt-free status output	AIC, CH3 PL8
7 and 8	Loadlock pump not in warning volt-free status output	AIC, CH6 PL15
9 and 10	Loadlock pump not in alarm volt-free status output	AIC, CH5 PL15

Table A3 - MCM connector signals

Pin numbers	Signal	Destination/ Source
1 and 2	Valve closed volt-free status input (from valve)	AIC, CH1 PL17
3 and 4	Valve open volt-free status input (from valve)	AIC, CH2 PL17
7 and 9	Open valve 24 V a.c. control output (to valve)	AIC, CH1 PL9

Table A4 - Gate valve connector signals

Pin numbers	Signal	Destination/ Source
1 and 2	EMS input from tool (closed in normal operation)	EMO pins 1 and 2
3 and 4	EMS output to tool (closed in normal operation)	EMO pins 3 and 4

Table A5 - Remote EMS connector signals

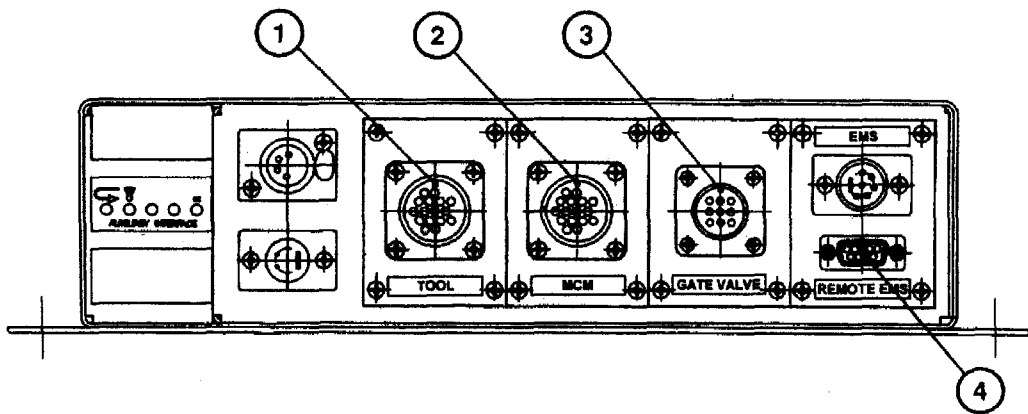

1. Tool connector
2. MCM connector
3. Gate valve connector
4. Remote EMS connector

Figure A1 - Interface connector panel

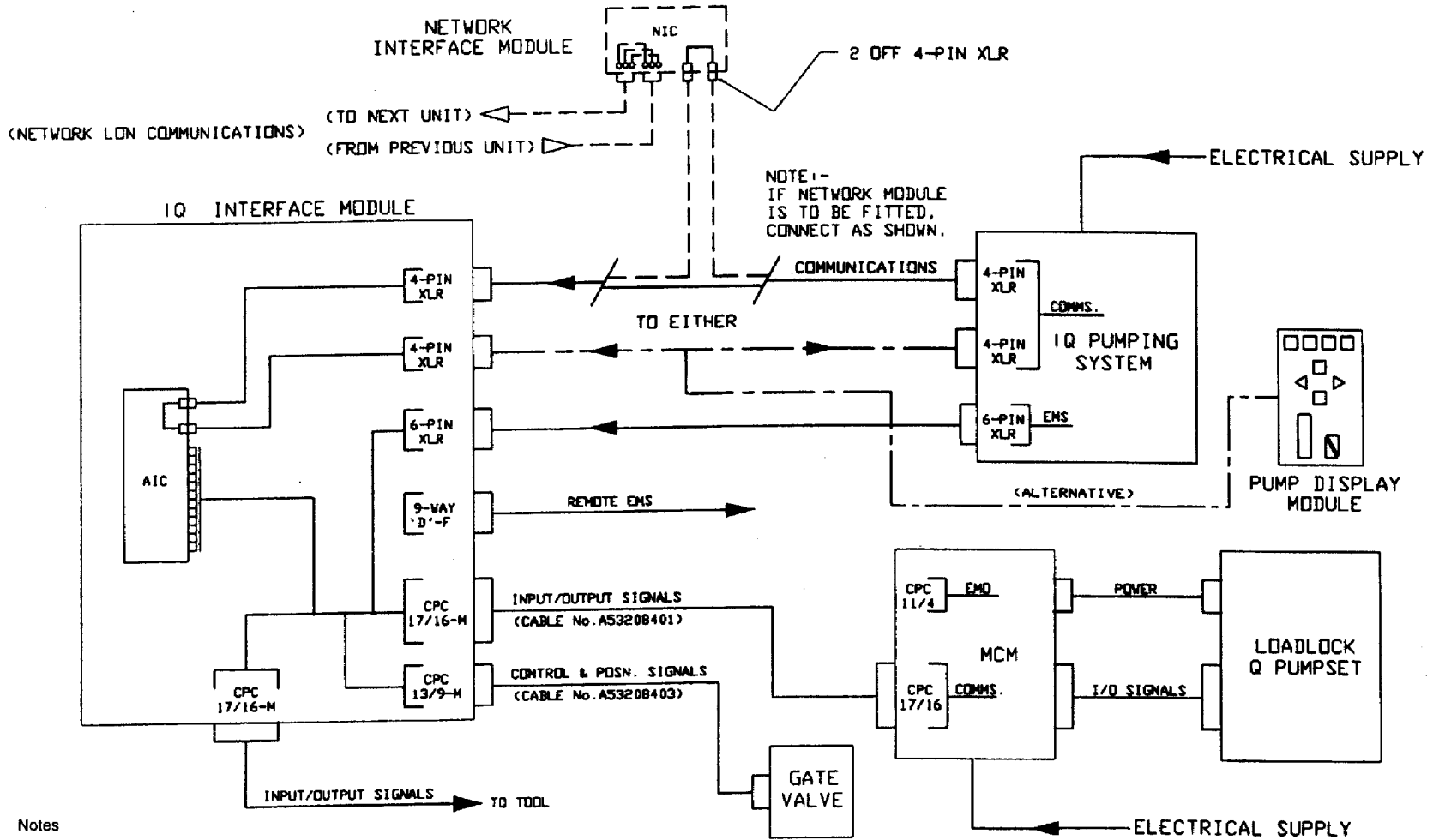

Figure A2 - Schematic diagram of the electrical connections

iQ Interface Module - Item Number A528-44-410

1 Introduction

This Amendment describes the details of this iQ Interface Module

2 Cards fitted

The following Interface Card is fitted in this iQ Interface Module:

- TIC (Tool Interface Card).

3 Connectors

The connector in Table A1 is fitted to the interface connector panel on this iQ Interface Module:

Connector name/number	Connector type	Figure A1 reference
Tool EMS J1	CPC 11/4-M	1
Tool EMS P2	CPC 11/4-F	2
Tool	CPC 17/16-M	3
EMS	XLR-6	4

Table A1 - Connector types

4 Use of connector pins

The signals available on the connectors are shown in Table A2 and Table A4. Refer to the appropriate sections of this instruction manual for electrical data for the signals available on the Tool Interface Card connectors and for information on the use of the signals.

Pin numbers	Signal	Destination/ Source
1	EMS output (closed in normal operation)	EMS chain
2 and 3	Internal link	-
4	Internal link	Tool EMS P2 pin 1

Table A2 - Tool Tool EMS J1 connector signals

Pin numbers	Signal	Destination/ Source
1	Internal link	Tool EMS J1 pin 4
2 and 3	Internal link	-
4	EMS output (closed in normal operation)	EMS chain

Table A3 - Tool EMS P2 connector signals

Pin numbers	Signal	Destination/ Source
1 and 2	Pumps on 24 V control input *	TIC, CH3 PL12
3 and 4	Pumps running volt-free status output	TIC, CH3 PL8
7 and 8	Pumps not in warning volt-free status output	TIC, CH4 PL8
9 and 10	Pumps not in alarm volt-free status output	TIC, CH5 PL7
11 and 12	Gas flow not in alarm volt-free status output	TIC, CH6 PL7
13 and 14	Final valve volt-free status output	TIC, CH7 PL6
15 and 16	Pumps on volt-free control input *	TIC, CH3 PL16

Note : * Only one type of 'pumps on' control signal may be used

Table A4 - Tool connector signals

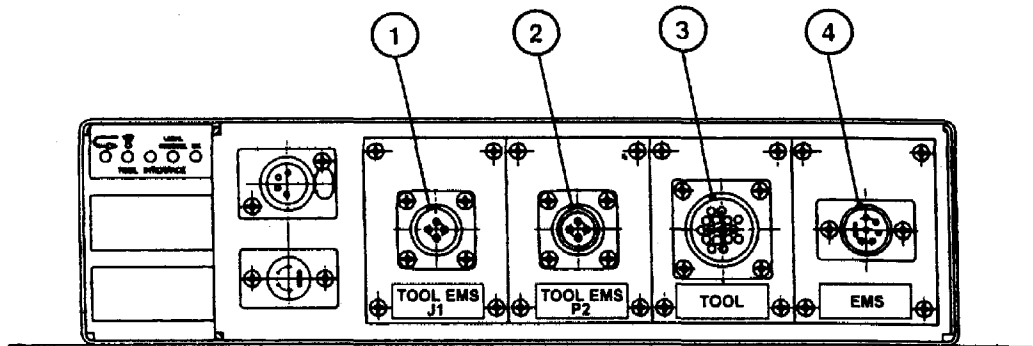

1. Tool EMS J1 connector
2. Tool EMS P2 connector
3. Tool connector
4. EMS connector

Figure A1 - Interface connector panel

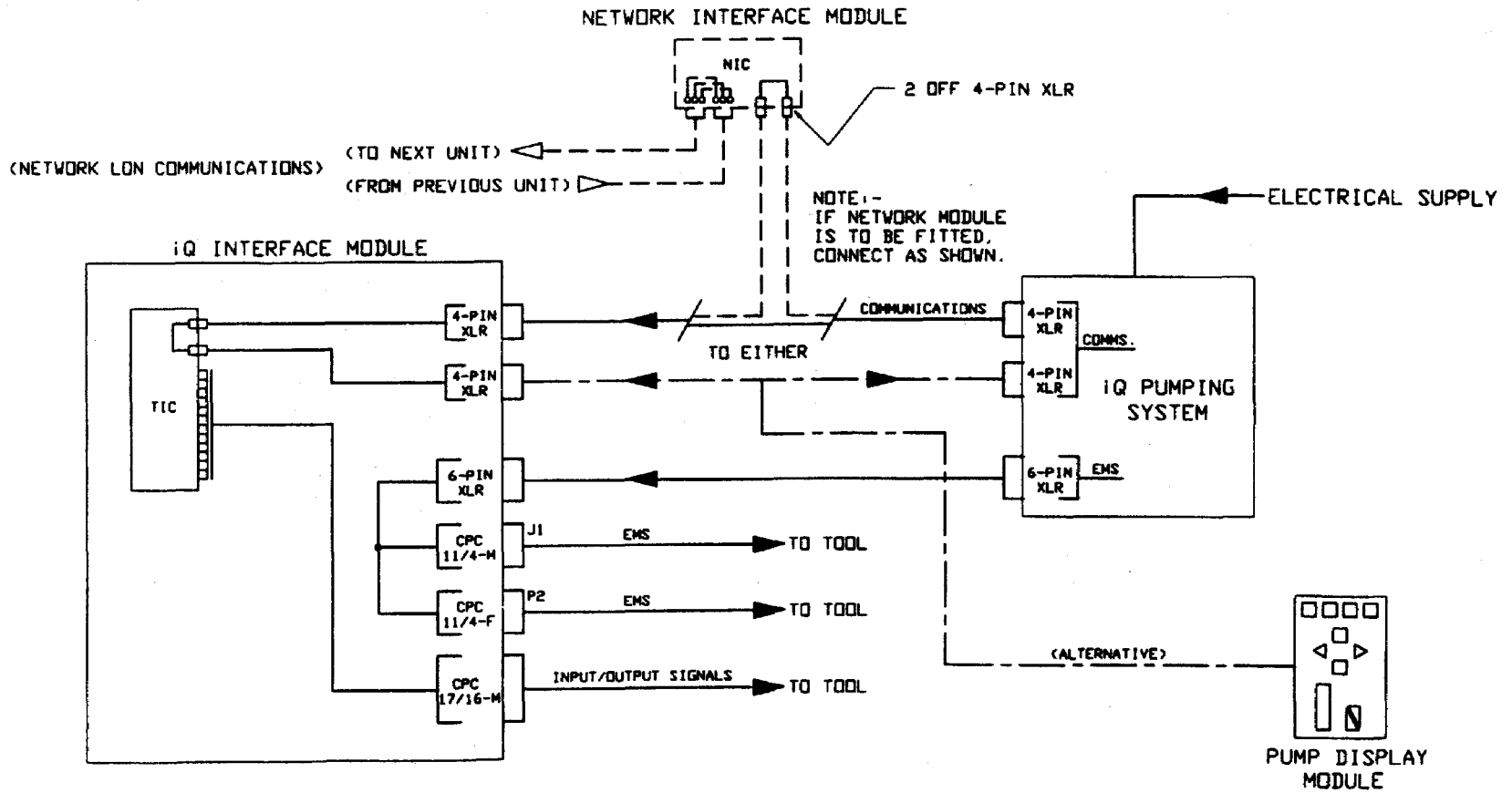

Notes

1. The Pump Display Module can be used with the iQ pumping system on its own without external communication.
2. Vacant XLR-4 pin communications connectors must have terminator plugs fitted.

Figure A2 - Schematic diagram of the electrical connections

iQ Interface Module - Item Number A528-44-413

1 Introduction

This Amendment describes the details of this iQ Interface Module

2 Mechanical data

This iQ Interface Module is larger than the standard iQ Interface Module, and its depth is 166.4 mm, not 86.5 mm as specified in the instruction manual.

The actual mass of this iQ Interface Module is specified on a rating plate on the iQ Interface Module.

3 Cards fitted

The following Interface Cards are fitted in this iQ Interface Module:

- TIC (Tool Interface Card)
- AIC (Auxiliary Interface Card).

4 Connectors

The connectors in Table A1 are fitted to the interface connector panel on this iQ Interface Module:

Connector name/number	Connector type	Figure A1 reference
Gate valve	CPC 13/9-M	1
MCM EMO	CPC 11/4-F	2
Tool EMS J1	CPC 11/4-M	3
Tool EMS P2	CPC 11/4-F	4
MCM	CPC 17/16-M	5
Loadlock	CPC 17/16-M	6
Process	CPC 17/16-M	7
EMS	XLR-6-M	8

Table A1 - Connector types

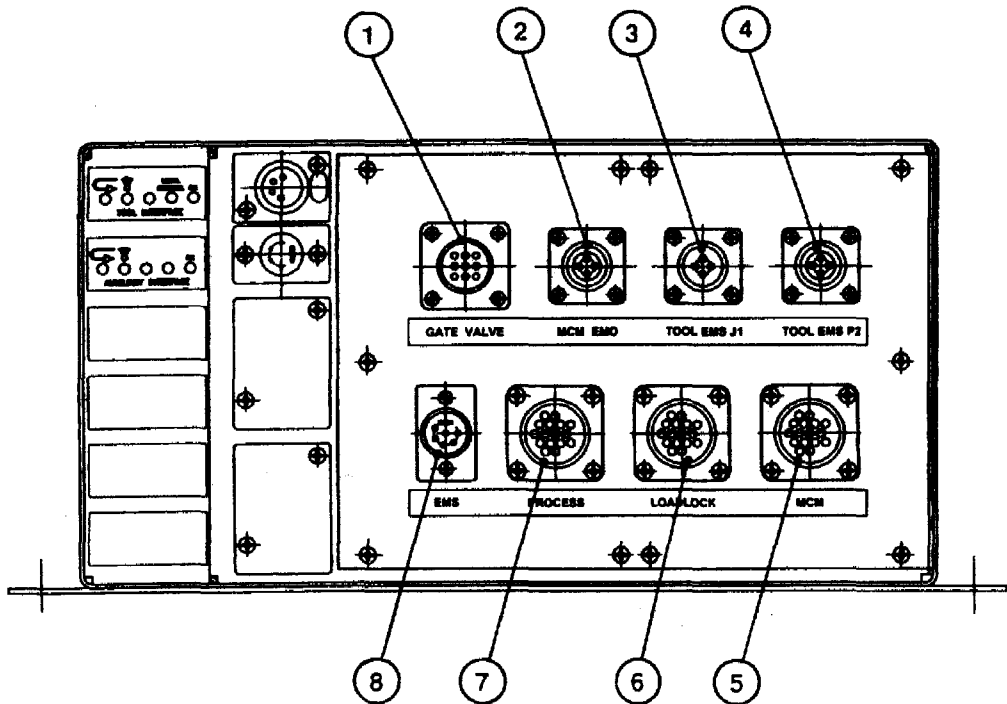

- | | |
|--------------------------|-----------------------|
| 1. Gate valve connector | 5. MCM connector |
| 2. MCM EMO connector | 6. Loadlock connector |
| 3. Tool EMS J1 connector | 7. Process connector |
| 4. Tool EMS P2 connector | 8. EMS connector |

Figure A1 - Interface connector panel

5 Use of connector pins

The signals available on the connectors are shown in Tables A2 to A8. Refer to the appropriate sections of this instruction manual for electrical data for the signals available on the Tool Interface Card and Auxiliary Interface Card connectors and for information on the use of the signals.

Pin numbers	Signal	Destination/Source
1 and 2	Valve closed volt-free status signal from valve	TIC, CH1 PL17
3 and 4	Valve open volt-free status signal from valve	TIC, CH2 PL17
7 and 9	Open valve 24 V a.c. control signal to valve	TIC, CH1 PL9

Table A2 - Gate valve connector signals

Pin numbers	Signal	Destination/ Source
1 and 2	EMO input from MCM (closed in normal operation)	MCM
3 and 4	Not used	-

Table A3 - MCM EMO connector signals

Pin numbers	Signal	Destination/ Source
1	EMS output to tool (closed in normal operation)	EMS pin 3
2 and 3	Internal link	-
4	Internal link	Tool P2 pin 1

Table A4 - Tool EMS J1 connector signals

Pin numbers	Signal	Destination/ Source
1	Internal link	Tool J1 pin 4
2 and 3	Internal link	-
4	EMS output to tool (closed in normal operation)	MCM EMO pin 2

Table A5 - Tool EMS P2 connector signals

Pin numbers	Signal	Destination/ Source
3 and 4	Loadlock pump running signal from pump	AIC, CH7 PL14
5 and 6	Loadlock pump on volt-free control signal to pump	AIC, CH3 PL8
7 and 8	Loadlock pump not in warning volt-free status signal from pump	AIC, CH6 PL15
9 and 10	Loadlock pump not in alarm volt-free status signal from pump	AIC, CH5 PL15

Table A6 - MCM connector signals

Pin numbers	Signal	Destination/ Source
1 and 2	Loadlock pump on 24 V a.c./d.c. control signal from tool	AIC, CH8 PL10
3 and 4	Loadlock pump running volt-free status signal to tool	AIC, CH6 PL7
7 and 8	Loadlock pump not in warning volt-free status signal to tool	AIC, CH5 PL7
9 and 10	Loadlock pump not in alarm volt-free status signal to tool	AIC, CH4 PL8

Table A7 - Loadlock connector signals

Pin numbers	Signal	Destination/ Source
1 and 2	Pumps on 24 V a.c./d.c. control signal *	TIC, CH3 PL12
3 and 4	Pumps running volt-free status signal	TIC, CH3 PL8
5 and 6	Open valve 24 V a.c./d.c. control signal	TIC, CH5 PL11
7 and 8	Pumps not in warning volt-free status signal	TIC, CH4 PL8
9 and 10	Pumps not in alarm volt-free status signal	TIC, CH5 PL7
11 and 12	Gas flow not in warning volt-free status signal	TIC, CH6 PL7
13 and 14	Final valve volt-free status signal	TIC, CH7 PL6
15 and 16	Pumps on volt-free control signal *	TIC, CH3 PL16

* Note: only one type of 'pumps on' control signal may be used.

Table A8 - Process connector signals

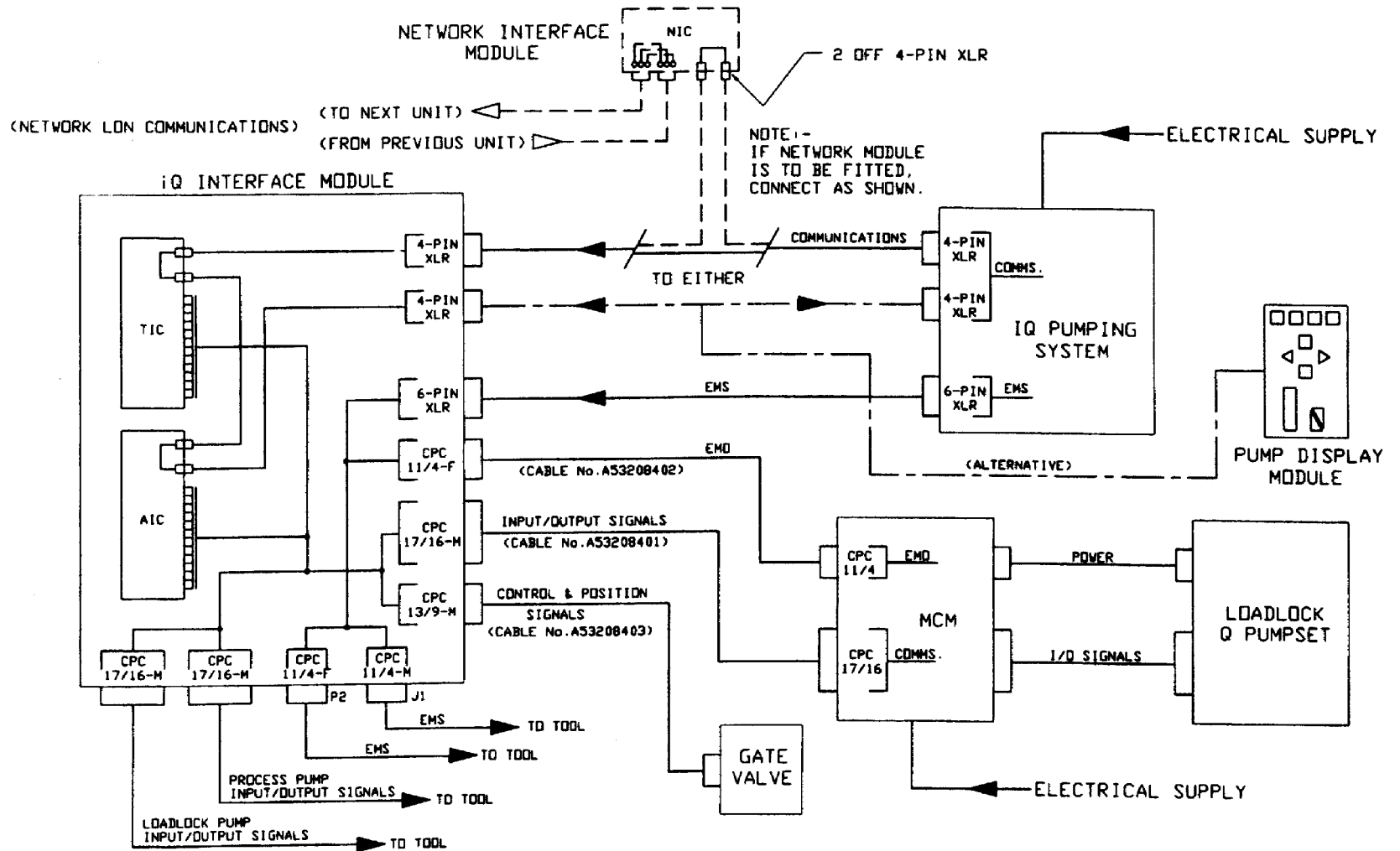

Notes

1. The Pump Display Module can be used with the iQ pumping system on its own without external communication.
2. Vacant XLR-4 pin communications connectors must have terminator plugs fitted.

Figure A2 - Schematic diagram of the electrical connections

iQ Interface Module - Item Number A528-44-420

1 Introduction

This Amendment describes the details of this iQ Interface Module

2 Cards fitted

The following Interface Card is fitted in this iQ Interface Module:

- TIC (Tool Interface Card).

3 Connectors

The connector in Table A1 is fitted to the interface connector panel on this iQ Interface Module:

Connector name/number	Connector type	Figure A1 reference
SK3 Tool	HAN16-F	1
SK4 Tool	STAF6-F	2

Table A1 - Connector types

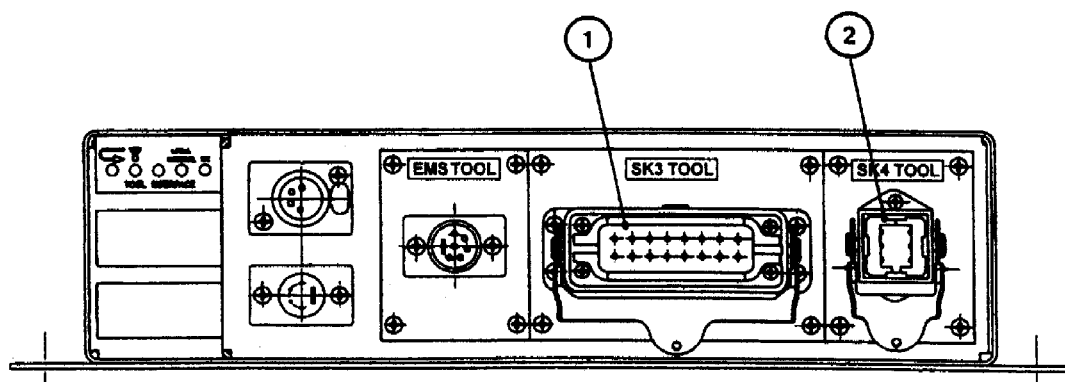

1. SK3 Tool
2. SK4 Tool

Figure A1 - Interface connector panel

4

Use of connector pins

The signals available on the connectors are shown in Tables A2 and A3. Refer to the appropriate sections of this instruction manual for electrical data for the signals available on the Tool Interface Card connectors and for information on the use of the signals.

Pin numbers	Signal	Destination/ Source
1 and 2	EMS output (closed in normal operation)	EMS connector
3 and 4	iQDP pump on volt-free control input	TIC, CH1 PL17
5 and 6	iQDP pump running volt-free status output	TIC, CH1 PL9
7 and 8	iQMB pump on volt-free control input	TIC, CH2 PL17
9 and 10	iQMB pump running volt-free status output	TIC, CH2 PL9
11 and 12	Pumps not in warning volt-free status output	TIC, CH4 PL8
13 and 14	Pumps not in alarm volt-free status output	TIC, CH5 PL7
15 and 16	External EMS input (closed in normal operation)	EMS connector

Table A2 - SK3 Tool connector signals

Pin numbers	Signal	Destination/ Source
1 and 2	Gas flow not in warning volt-free status output	TIC, CH6 PL7
3 and 4	24 V a.c. output	-

Table A3 - SK4 Tool connector signals

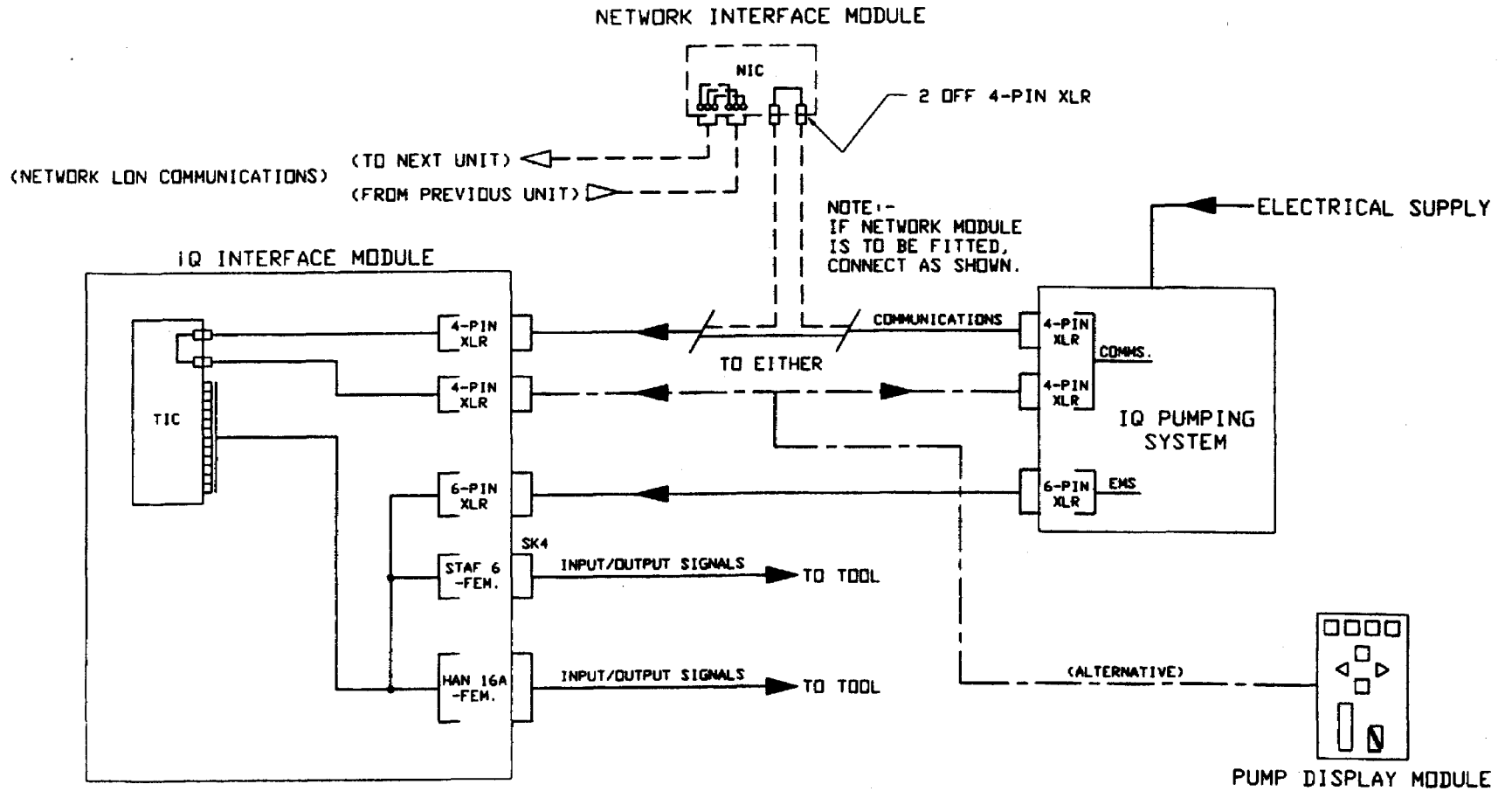

Notes

1. The Pump Display Module can be used with the IQ pumping system on its own without external communication.
2. Vacant XLR-4 pin communications connectors must have terminator plugs fitted.

Figure A2 - Schematic diagram of the electrical connections

iQ Interface Module - Item Number A528-44-430

1 Introduction

This Amendment describes the details of this iQ Interface Module

2 Cards fitted

The following Interface Card is fitted in this iQ Interface Module:

- TIC (Tool Interface Card).

3 Connectors

The connector in Table A1 is fitted to the interface connector panel on this iQ Interface Module:

Connector name/number	Connector type	Figure A1 reference
Tool	CPC 17/16-M	1
Tool EMS	CPC 11/4-M	2

Table A1 - Connector types

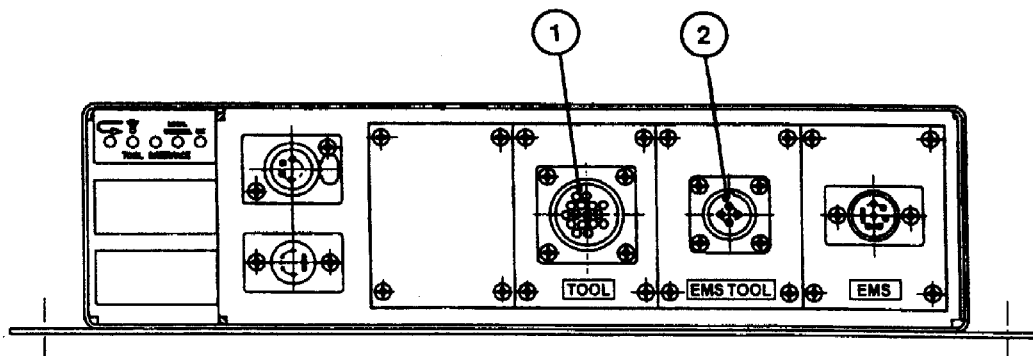

1. Tool
2. Tool EMS

Figure A1 - Interface connector panel

Use of connector pins

The signals available on the connectors are shown in Table A2 and Table A3. Refer to the appropriate sections of this instruction manual for electrical data for the signals available on the Tool Interface Card connectors and for information on the use of the signals.

Pin numbers	Signal	Destination/ Source
1 and 2	Both pumps on 24 V control input	TIC, CH3 PL12
3 and 4	Pumps running volt-free status output	TIC, CH3 PL8
5 and 6	Both pumps on volt-free control input	TIC, CH3 PL16
7 and 8	Pumps not in warning volt-free status output	TIC, CH4 PL8
9 and 10	Pumps not in alarm volt-free status output	TIC, CH5 PL7
11 and 12	Gas flow not in warning volt-free status output	TIC, CH6 PL7

Table A2 - Tool connector signals

Pin numbers	Signal	Destination/ Source
1 and 2	EMO output (N/C)	Tool
3 and 4	Not connected	-

Table A3 - Tool EMO connector signals

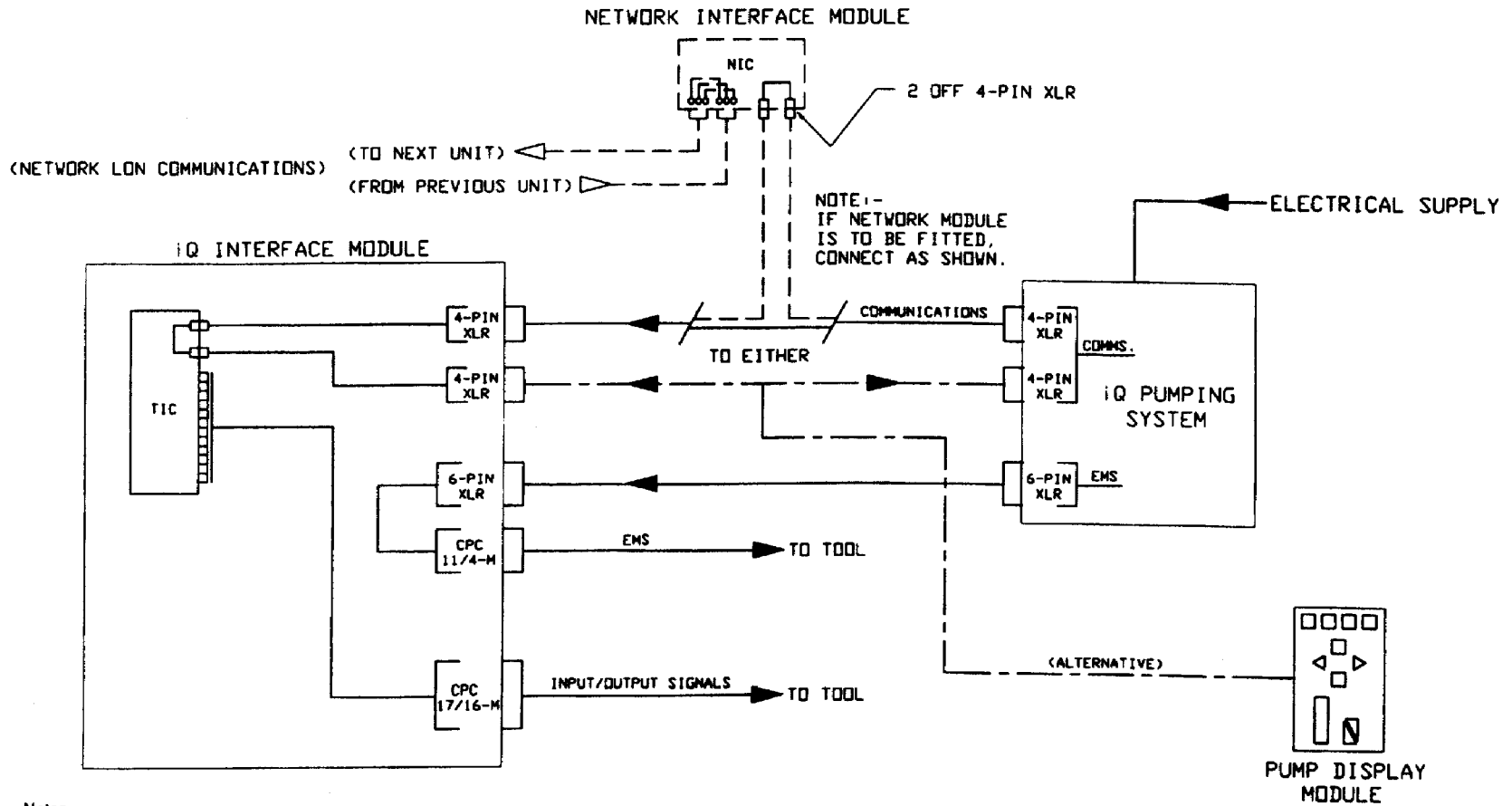

Notes

1. The Pump Display Module can be used with the iQ pumping system on its own without external communication.
2. Vacant XLR-4 pin communications connectors must have terminator plugs fitted.

Figure A2 - Schematic diagram of the electrical connections

iQ Interface Module - Item Number A528-44-433

1 Introduction

This Amendment describes the details of this iQ Interface Module

2 Mechanical data

This iQ Interface Module is larger than the standard iQ Interface Module, and its depth is 166.4 mm, not 86.5 mm as specified in the instruction manual.

The mass of this iQ Interface Module is specified on a rating plate on the iQ Interface Module.

3 Cards fitted

The following Interface Cards are fitted in this iQ Interface Module:

- TIC (Tool Interface Card)
- AIC (Auxiliary Interface Card).

4 Connectors

The connectors in Table A1 are fitted to the interface connector panel on this iQ Interface Module:

Connector name/number	Connector type	Figure A1 reference
Gate valve	CPC 13/9-M	1
EMS output	CPC 11/4-M	2
MCM EMO	CPC 11/4-F	3
MCM	CPC 17/16-M	4
Loadlock	CPC 17/16-M	5
Process	CPC 17/16-M	6
EMS input	XLR-6	7

Table A1 - Connector types

5 Use of connector pins

The signals available on the connectors are shown in Tables A2 to A7. Refer to the appropriate sections of this instruction manual for electrical data for the signals available on the connectors and for information on the use of the signals.

Pin numbers	Signal	Destination/ Source
1 and 2	Valve closed volt-free status input (from valve)	AIC, CH1 PL17
3 and 4	Valve open volt-free status input (from valve)	AIC, CH2 PL17
7 and 9	Open valve 24 V a.c. control output (to valve)	AIC, CH1 PL9

Table A2 - Gate valve connector signals

Pin numbers	Signal	Destination/ Source
1 and 2	EMS output (closed in normal operation)	Tool
3 and 4	Not connected	-

Table A3 - EMS output connector signals

Pin numbers	Signal	Destination/ Source
1 and 2	EMO input (closed in normal operation)	MCM
3 and 4	Not connected	-

Table A4 - MCM EMO connector signals

Pin numbers	Signal	Destination/ Source
3 and 4	Loadlock pump running volt-free status input (from pump)	AIC, CH7 PL14
5 and 6	Loadlock pump on volt-free control output (to pump)	AIC, CH3 PL8
7 and 8	Loadlock pump not in warning volt-free status input (from pump)	AIC, CH6 PL15
9 and 10	Loadlock pump not in alarm volt-free status input (from Pump)	AIC, CH5 PL15

Table A5 - MCM connector signals

Pin numbers	Signal	Destination/ Source
1 and 2	Loadlock pump on 24 V control input (from tool) *	AIC, CH8 PL10
3 and 4	Loadlock pump running volt-free status output (to tool)	AIC, CH6 PL7
5 and 6	Both pumps on volt-free control input (from tool) *	AIC, CH8 PL14
7 and 8	Loadlock pump not in warning volt-free status output (to tool)	AIC, CH5 PL7
9 and 10	Loadlock pump not in alarm volt-free status output (to tool)	AIC, CH4 PL8

* Note : only one of these control inputs can be used.

Table A5 - MCM EMO connector signals

Pin numbers	Signal	Destination/ Source
1 and 2	Both pumps on 24 V control input *	TIC, CH3 PL12
3 and 4	Pumps running volt-free status output	TIC, CH3 PL8
5 and 6	Both pumps on volt-free control input *	TIC, CH3 PL16
7 and 8	Pumps not in warning volt-free status output	TIC, CH4 PL8
9 and 10	Pumps not in alarm volt-free status output	TIC, CH5 PL7

* Note : only one of these control inputs can be used.

Table A6 - Process connector signals

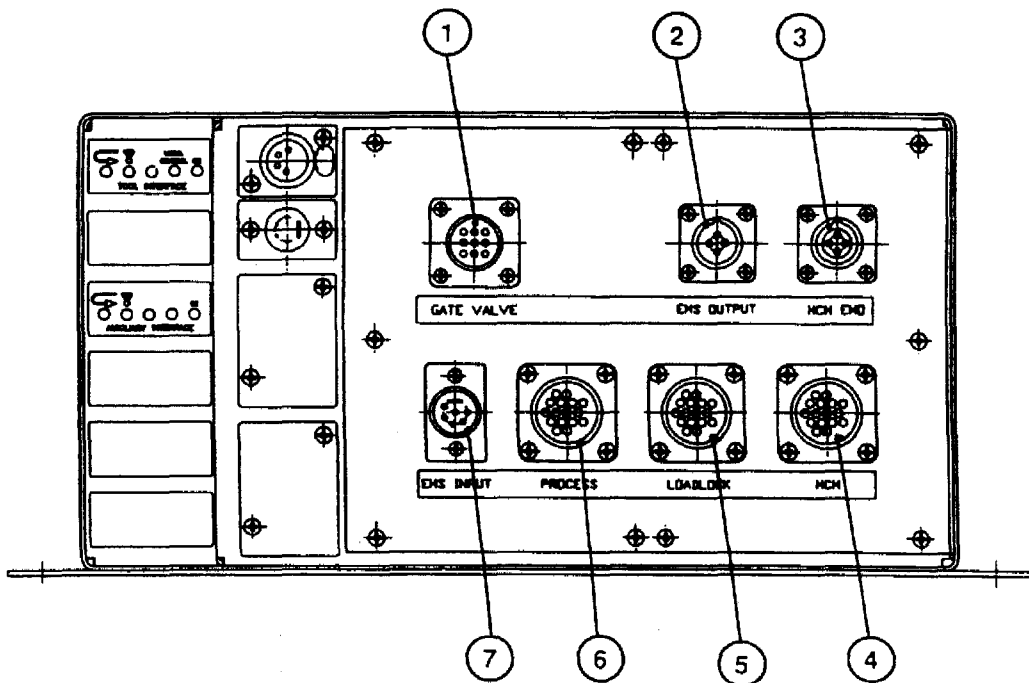

- | | |
|-------------------------|------------------------|
| 1. Gate valve connector | 5. Loadlock connector |
| 2. EMS output connector | 6. Process connector |
| 3. MCM EMO connector | 7. EMS input connector |
| 4. MCM connector | |

Figure A1 - Interface connector panel

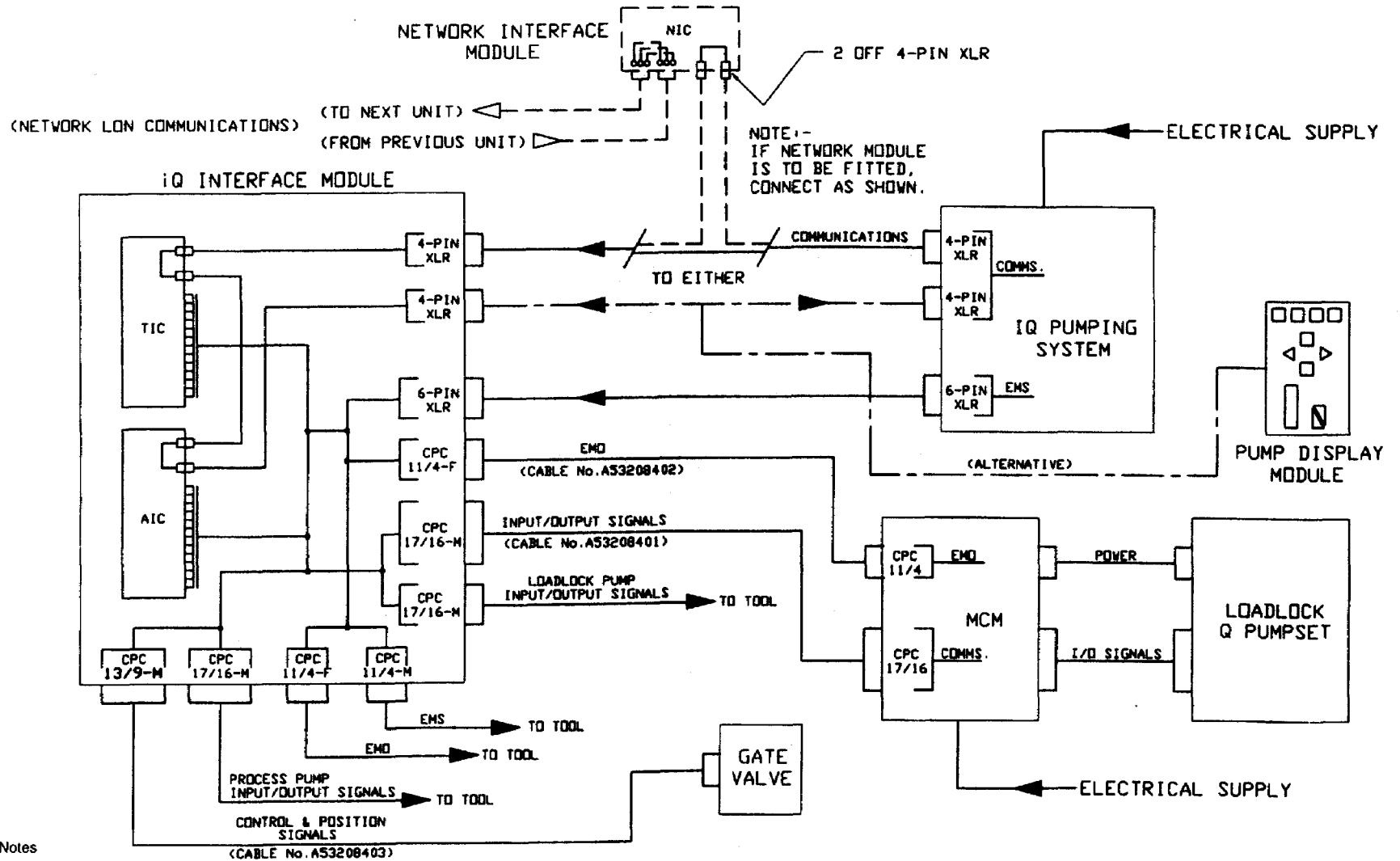

Notes

1. The Pump Display Module can be used with the iQ pumping system on its own without external communication.
2. Vacant XLR-4 pin communications connectors must have terminator plugs fitted.

Figure A2 - Schematic diagram of the electrical connections

iQ Interface Module - Item Number A528-44-450

1 Introduction

This Amendment describes the details of this iQ Interface Module

2 Cards fitted

The following Interface Card is fitted in this iQ Interface Module:

- TIC (Tool Interface Card).

3 Connectors

The connector in Table A1 is fitted to the interface connector panel on this iQ Interface Module:

Connector name/number	Connector type	Figure A1 reference
Process pump	CPC 17/16-M	1

Table A1 - Connector types

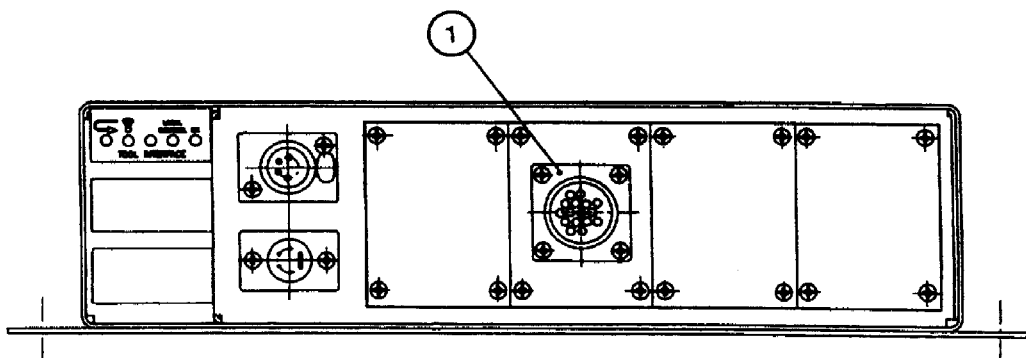

1. Process pump connector

Figure A1 - Interface connector panel

Use of connector pins

The signals available on the connectors are shown in Table A2. Refer to the appropriate sections of this instruction manual for electrical data for the signals available on the Tool Interface Card connectors and for information on the use of the signals.

Pin numbers	Signal	Destination/ Source
1 and 2	Pump on volt-free control input	TIC, CH3 PL16
3 and 4	Pump running volt-free status output	TIC, CH1 PL9
5 and 6	Exhaust pressure not in warning volt-free status output	TIC, CH8 PL6
7 and 8	Gas flow not in warning volt-free status output	TIC, CH6 PL7
9 and 10	Pump not in alarm volt-free status output	TIC, CH5 PL7
11	Earth (ground)	-

Table A2 - Process pump connector signals

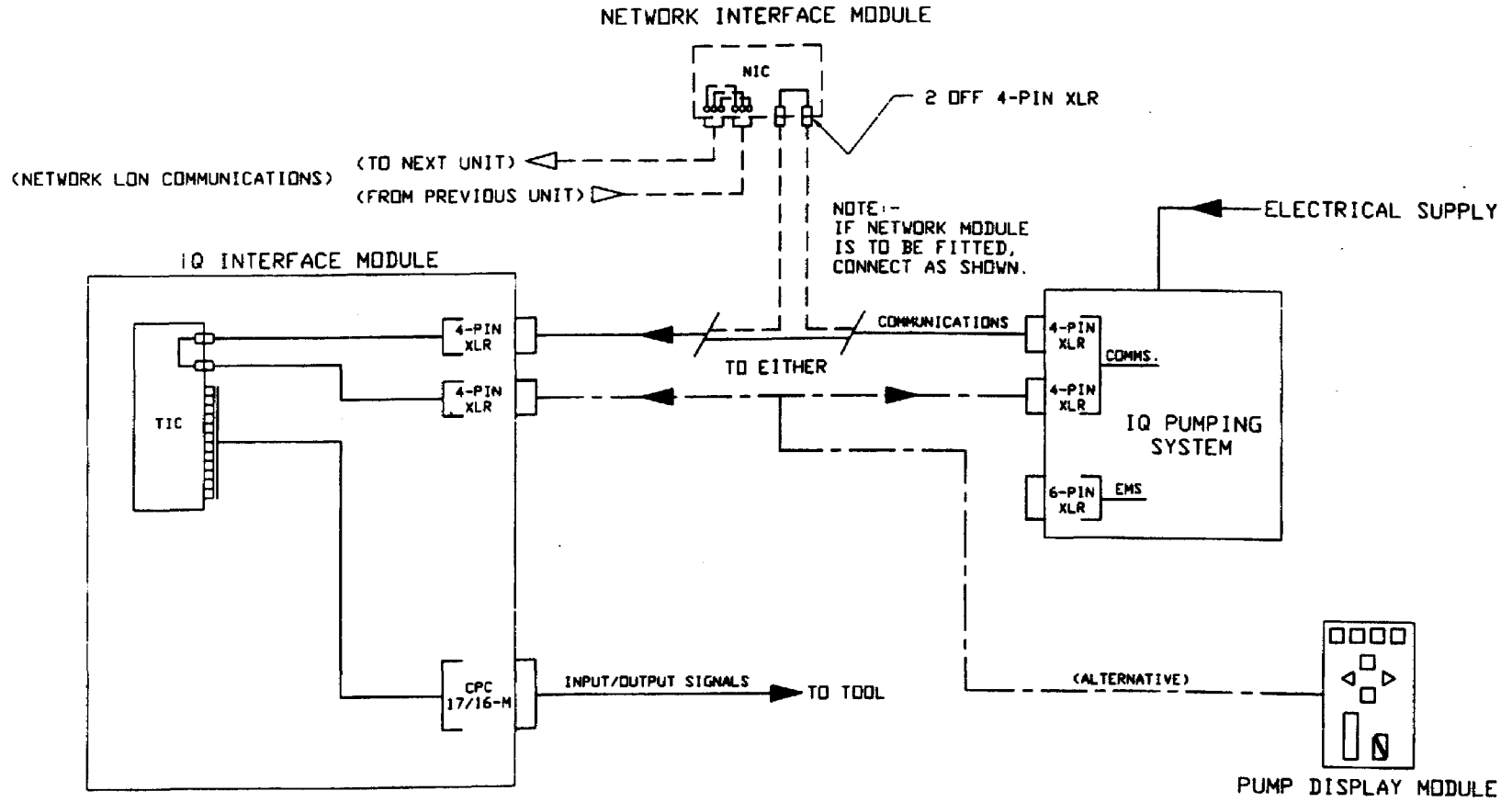

Notes

1. The Pump Display Module can be used with the IQ pumping system on its own without external communication.
2. Vacant XLR-4 pin communications connectors must have terminator plugs fitted.

Figure A2 - Schematic diagram of the electrical connections

iQ Interface Module - Item Number A528-44-454

1 Introduction

This Amendment describes the details of this iQ Interface Module

2 Mechanical data

This iQ Interface Module is larger than the standard iQ Interface Module, and its depth is 166.4 mm, not 86.5 mm as specified in the instruction manual.

The mass of this iQ Interface Module is specified on a rating plate on the iQ Interface Module.

3 Cards fitted

The following Interface Cards are fitted in this iQ Interface Module:

- TIC1 (Tool Interface Card 1)
- TIC2 (Tool Interface Card 2)

4 Connectors

The connectors in Table A1 are fitted to the interface connector panel on this iQ Interface Module:

Connector name/number	Connector type	Figure A1 reference
Transfer EMS	XLR-6	1
Transfer valve	CPC 11/4-M	2
Process valve	CPC 11/4-M	3
J2 EMS Tool	CPC 11/4-F	4
J1 EMS Tool	CPC 11/4-F	5
Process EMS	XLR-6	6

Table A1 - Connector types

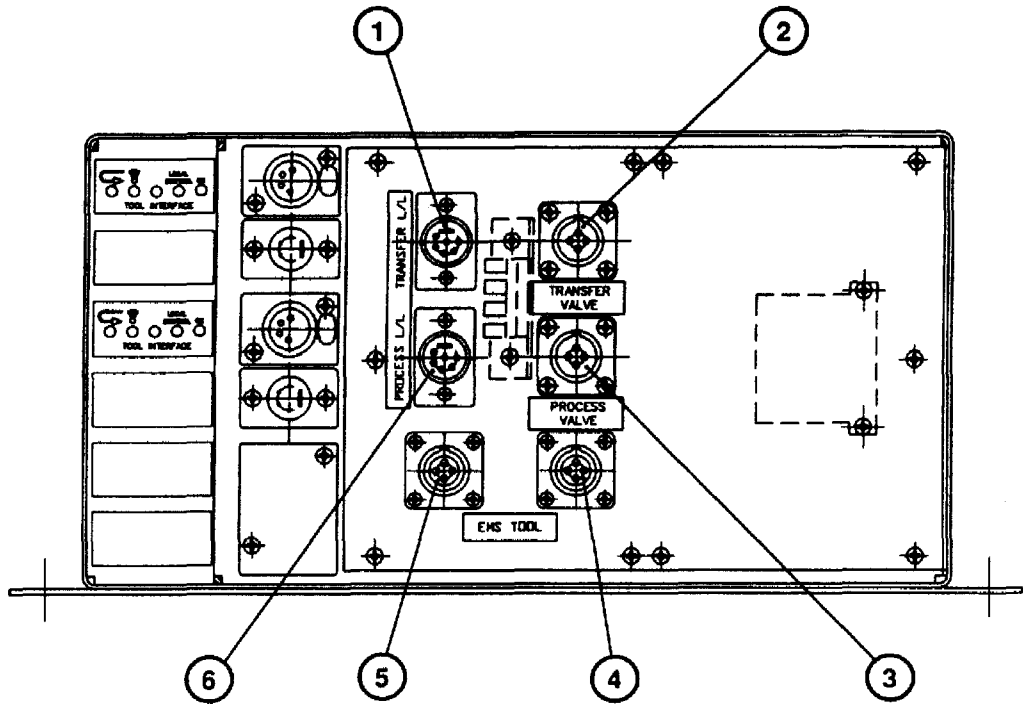

- | | |
|-----------------------------|--------------------------|
| 1. Transfer EMS connector | 4. J2 connector EMS tool |
| 2. Transfer valve connector | 5. J1 connector EMS tool |
| 3. Process valve connector | 6. Process EMS connector |

Figure A1 - Interface connector panel

5 Use of connector pins

The signals available on the connectors are shown in Tables A2 to A5. Refer to the appropriate sections of this instruction manual for electrical data for the signals available on the Tool Interface Cards connectors and for information on the use of the signals.

Pin numbers	Signal	Destination/ Source
1 and 2	Transfer pump running volt-free status output	TIC1, CH1 PL9

Table A2 - Transfer valve connector signals

Pin numbers	Signal	Destination/ Source
3 and 4	Process pump running volt-free status output	TIC2, CH2 PL9

Table A3 - Process valve connector signals

Pin numbers	Signal	Destination/ Source
1 and 2	EMS output - closed in normal operation	Tool EMS chain
3 and 4	24 V a.c. pump enable input from tool	Tool

Table A4 - J2 EMS toolconnector signals

Pin numbers	Signal	Destination/ Source
1 and 2	EMS output - closed in normal operation	Tool EMS chain
3 and 4	24 V a.c. pump enable input from tool	Tool

Table A6 - J1 EMS tool connector signals

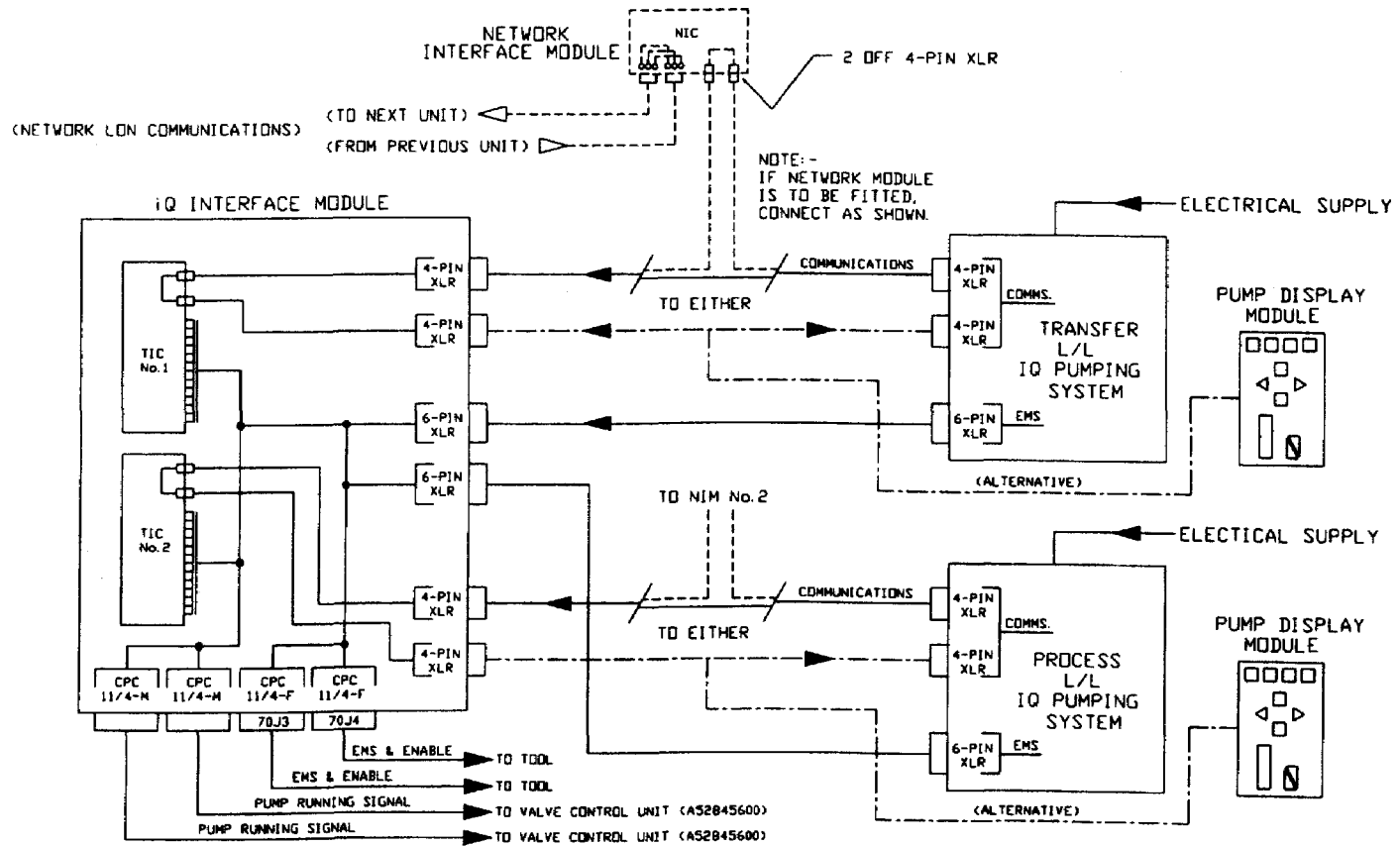

Notes

1. The Pump Display Module can be used with the iQ pumping system on its own without external communication.
2. Vacant XLR-4 pin communications connectors must have terminator plugs fitted.

Figure A2 - Schematic diagram of the electrical connections

iQ Interface Module - Item Number A528-44-458

1 Introduction

This Amendment describes the details of this iQ Interface Module

2 Cards fitted

The following Interface Card is fitted in this iQ Interface Module:

- TIC (Tool Interface Card).

3 Connectors

The connector in Table A1 is fitted to the interface connector panel on this iQ Interface Module:

Connector name/number	Connector type	Figure A1 reference
Loadlock pump	CPC 17/16-M	1

Table A1 - Connector types

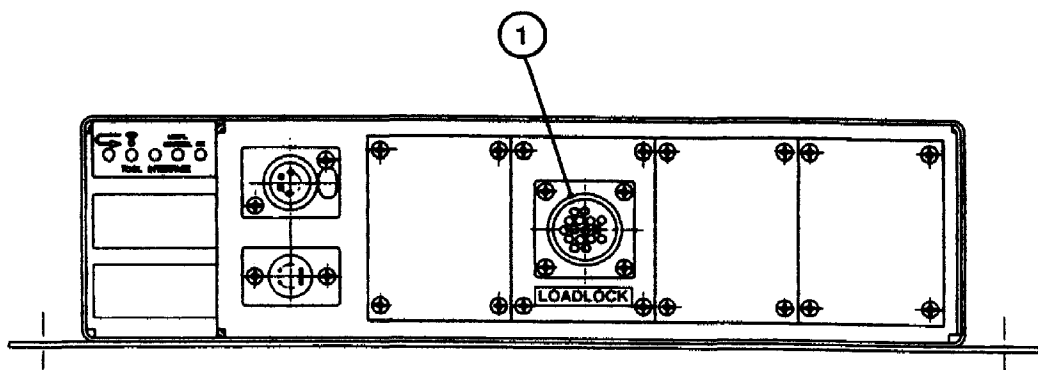

1. Loadlock pump connector

Figure A1 - Interface connector panel

4 Use of connector pins

The signals available on the connectors are shown in Table A2. Refer to the appropriate sections of this instruction manual for electrical data for the signals available on the Tool Interface Card connectors and for information on the use of the signals.

Pin numbers	Signal	Destination/ Source
1 and 2	Loadlock pump on volt-free control input	TIC, CH1 PL17
3 and 4	Loadlock pump running volt-free status output	TIC, CH1 PL9
5 and 6	Loadlock pump not in alarm volt-free status output	TIC, CH5 PL7
7	Earth	-

Table A2 - Loadlock pump connector signals

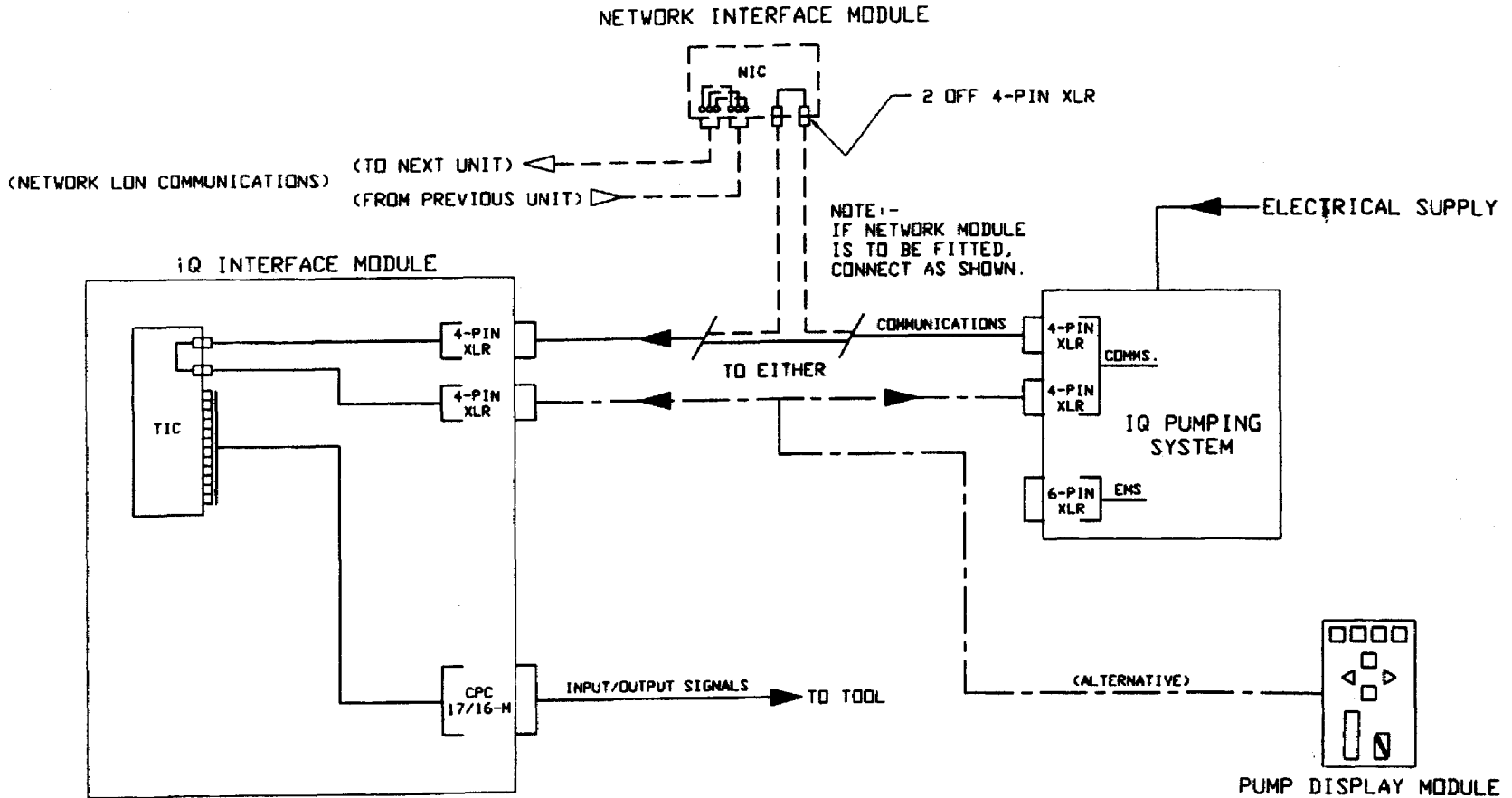

Notes

1. The Pump Display Module can be used with the iQ pumping system on its own without external communication.
2. Vacant XLR-4 pin communications connectors must have terminator plugs fitted.

Figure A2 - Schematic diagram of the electrical connections

iQ Interface Module - Item Number A528-44-460

1 Introduction

This Amendment describes the details of this iQ Interface Module

2 Cards fitted

The following Interface Card is fitted in this iQ Interface Module:

- Tool Interface Card.

3 Connectors

The connector in Table A1 is fitted to the interface connector panel on this iQ Interface Module:

Connector name/number	Connector type	Figure A1 reference
Tool connector	25-pin 'D' type male	1

Table A1 - Connector type

4 Use of connector pins

The signals available on the connector are shown in Table A2. Refer to the appropriate sections of this instruction manual for electrical data for the signals available on the Tool Interface Card connectors and for information on the use of the signals.

Pin numbers	Signal	Destination/Source
1 and 14	Both pump on volt-free control input	TIC, CH3 PL16
2 and 15	Process on volt-free control input	TIC, CH4 PL16
3 and 16	Open valve volt-free control input	TIC, CH5 PL15
4 and 17	Run til crash volt-free control input	TIC, CH6 PL15
5 and 18	Auto shutdown volt-free control input	TIC, CH7 PL14
8 and 20	Pumps running volt-free status output	TIC, CH3 PL8
9 and 21	Pumps not in warning (excluding exhaust pressure warning) volt-free status output	TIC, CH4 PL8
10 and 22	Pump not in alarm volt-free status output	TIC, CH5 PL7
11 and 23	Gas flow not in warning volt-free status output	TIC, CH6 PL7
12 and 24	Water flow volt-free status output	TIC, CH7 PL6
13 and 25	Exhaust pressure not in warning volt-free status output	TIC, CH8 PL6

Table A2 - Tool connector signals

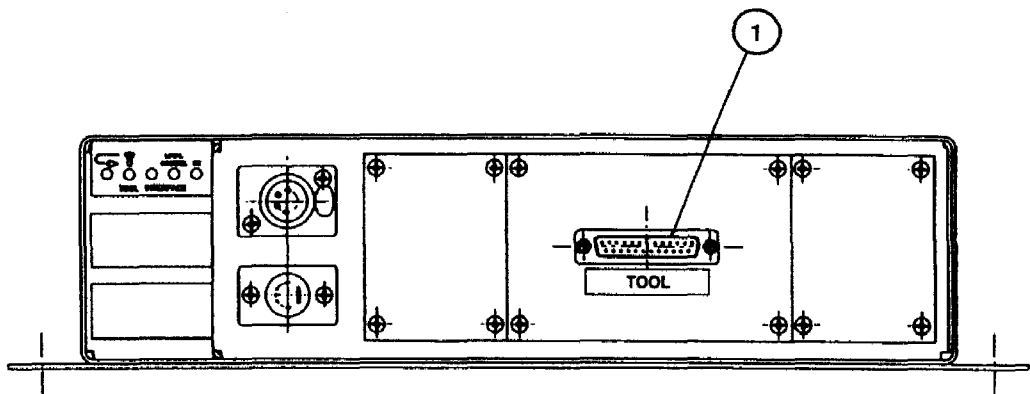

1. Tool connector

Figure A1 - Interface connector panel

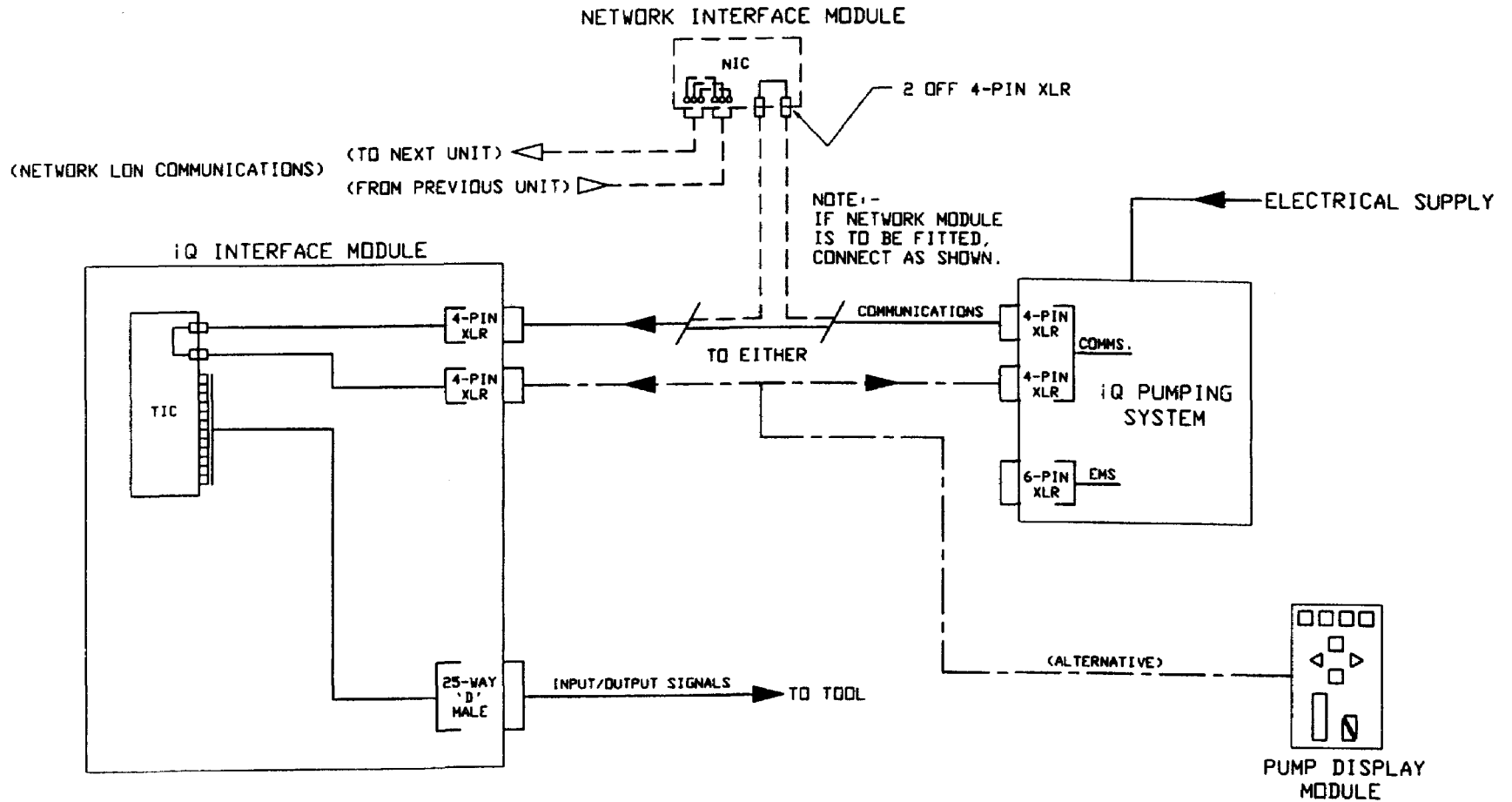

Notes

1. The Pump Display Module can be used with the iQ pumping system on its own without external communication.
2. Vacant XLR-4 pin communications connectors must have terminator plugs fitted.

Figure A2 - Schematic diagram of the electrical connections

iQ Interface Module - Item Number A528-44-463

1 Introduction

This Amendment describes the details of this iQ Interface Module.

2 Cards fitted

The following Interface Card is fitted in this iQ Interface Module:

- TIC (Tool Interface Card)
- AIC (Auxiliary Interface Card)

3 Connectors

The connectors in Table A1 are fitted to the interface connector panel on this iQ Interface Module:

Connector name/number	Connector type	Figure A1 reference
Tool	25-way D.-conn.-M	1
Valve	CPC 13/9-M	2
EMS	XLR-6	3

Table A1 - Connector types

4

Use of connector pins

The signals available on the connectors are shown in Tables A2 to A3. Refer to the appropriate sections of this instruction manual for electrical data for the signals available on the Tool Interface Card and Auxiliary Card connectors and for information on the use of the signals.

Pin numbers	Signal	Destination/ Source
1 and 14	Both pumps on volt-free control input	TIC, CH3 PL16
2 and 15	Process on volt-free control input	TIC, CH4 PL16
3 and 16	Open valve volt-free control input	TIC, CH5 PL15
4 and 17	Run til crash volt-free control input	TIC, CH6 PL15
5 and 18	Auto shut-down volt-free control input	TIC, CH7 PL14
8 and 20	Pumps running volt-free status output	TIC, CH3 PL8
9 and 21	Pumps not in warning volt-free status output	TIC, CH4 PL8
10 and 22	Pumps not in alarm volt-free status output	TIC, CH5 PL7
11 and 23	Gas flow not in warning volt-free status output	TIC, CH6 PL7
12 and 24	Pumps not in warning water flow volt-free status output	TIC, CH7 PL6
13 and 25	No exhaust pressure warning volt-free status output	TIC, CH8 PL6

Table A2 - Tool connector signals

Pin numbers	Signal	Destination/ Source
1 and 2	Valve closed volt-free status input (from valve)	AIC, CH1 PL17
3 and 4	Valve open volt-free status input (from valve)	AIC, CH2 PL17
7 and 9	Open/close valve 24 V a.c. control input (to valve)	AIC, CH1 PL9

Table A3 - Valve connector signals

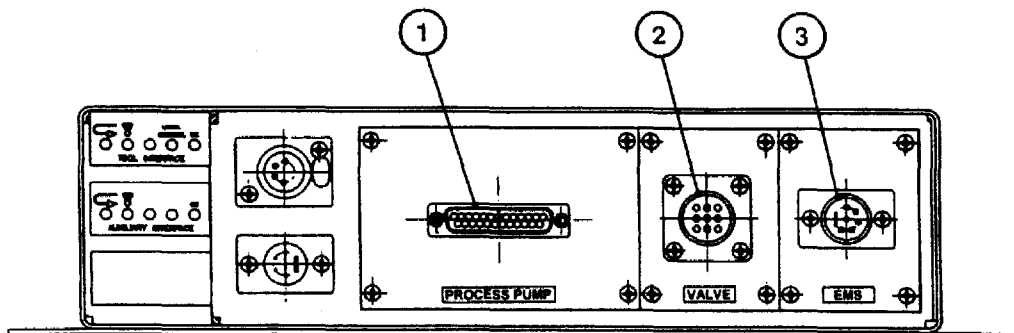

- 1. Tool connector
- 2. Valve connector
- 3. EMS connector

Figure A1 - Interface connector panel

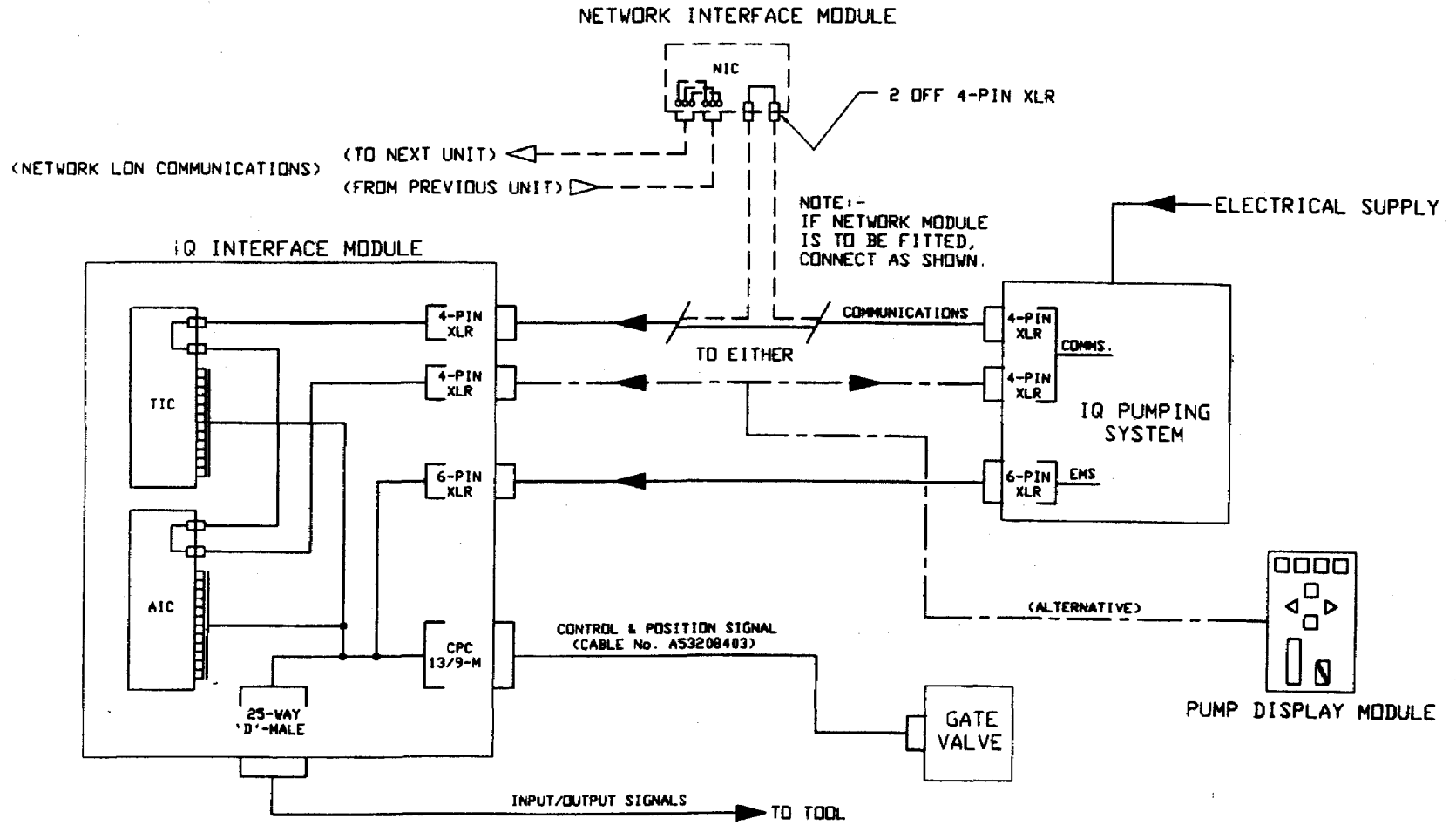

Notes

1. The Pump Display Module can be used with the iQ pumping system on its own without external communication.
2. Vacant XLR-4 pin communications connectors must have terminator plugs fitted.

Figure A2 - Schematic diagram of the electrical connections

iQ Interface Module - Item Number A528-44-473

1 Introduction

This Amendment describes the details of this iQ Interface Module

2 Cards fitted

The following Interface Cards are fitted in this iQ Interface Module:

- TIC (Tool Interface Card)
- AIC (Auxiliary Interface Card).

3 Connectors

The connectors in Table A1 are fitted to the interface connector panel on this iQ Interface Module:

Connector name/number	Connector type	Figure A1 reference
MCM	CPC 17/16-M	1
70J1 Tool EMS	CPC 13/9-M	2
70J2 Tool	37-way D. Conn-F	3
EMS	XLR-6	4
MCM EMO	CPC 11/4-F	5
70J3 Gas box	CPC 11/4-M	6

Table A1 - Connector types

Use of connector pins

The signals available on the connectors are shown in Tables A2 to A6. Refer to the appropriate sections of this instruction manual for electrical data for the signals available on the connectors and for information on the use of the signals.

Pin numbers	Signal	Destination/Source
3 and 4	Loadlock pump running volt-free contact input	AIC, CH7 PL14
5 and 6	Loadlock pump on volt-free output signal	AIC, CH3 PL8
7 and 8	Loadlock pump not in warning volt-free contact input	AIC, CH6 PL15
9 and 10	Loadlock pump not in alarm volt-free contact input	AIC, CH5 PL15

Table A2 - MCM connector signals

Pin numbers	Signal	Destination/Source
1 and 2	EMS output to tool (closed in normal operation)	EMS/MCM EMO
3 and 4	EMS input from tool (closed in normal operation)	EMS
5 and 6	Procrss pump running volt-free status output to tool	TIC, CH1 PL9

Table A3 - 70J1 Tool EMS connector signals

Pin numbers	Signal	Destination/Source
1 and 20	Process pump not in warning volt-free status output	TIC, CH4 PL8
2 and 21	Process pump running volt-free status output	TIC, CH3 PL8
3 and 22	Linked	-
5 and 24	Linked	-
10 and 29	Loadlock pump not failed volt-free status output	AIC, CH4 & CH5
11 and 30	Loadlock pump running volt-free status output	AIC, CH6 PL7
36 and 37	Process pump gas flow not in warning volt-free status output	TIC, CH6 PL7

Table A4 - 70J2 Tool connector signals

Pin numbers	Signal	Destination/Source
1 and 2	EMO input from MCM (closed in normal operation)	MCM
3 and 4	Not connected	-

Table A5 - MCM EMO connector signals

Pin numbers	Signal	Destination/ Source
1 and 2	Linked	-
3 and 4	Gas Box disable	70J2 pins 34 & 15

Table A6 - 70J3 Gas box connector signals

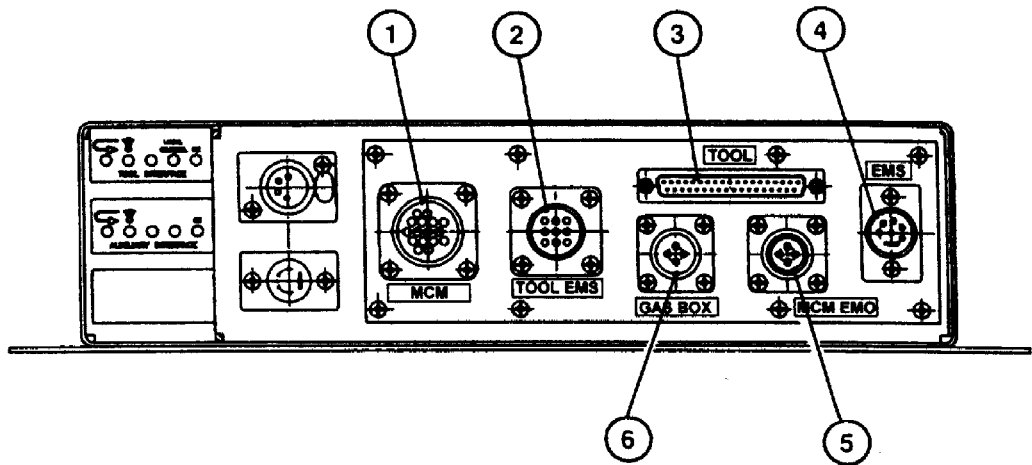

- | | |
|----------------------------|---------------------------|
| 1. MCM connector | 4. EMS connector |
| 2. 70J1 Tool EMS connector | 5. MCM EMO connector |
| 3. 70J2 Tool connector | 6. 70J3 Gas box connector |

Figure A1 - Interface connector panel

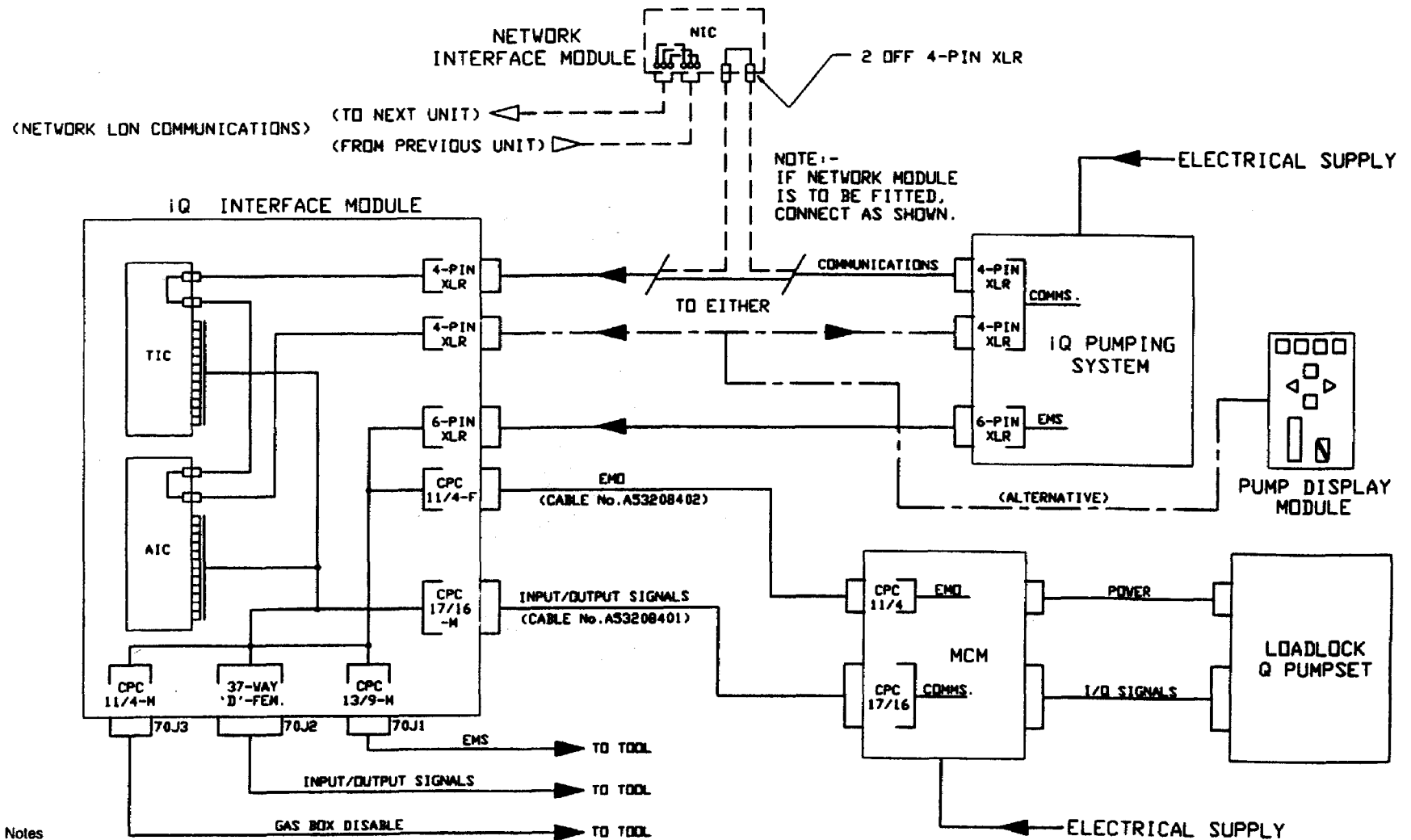

Notes

1. The Pump Display Module can be used with the iQ pumping system on its own without external communication.
2. Vacant XLR-4 pin communications connectors must have terminator plugs fitted.

Figure A2 - Schematic diagram of the electrical connections

iQ Interface Module - Item Number A528-44-480

1 Introduction

This Amendment describes the details of this iQ Interface Module

2 Cards fitted

The following Interface Card is fitted in this iQ Interface Module:

- TIC (Tool Interface Card).

3 Connectors

The connector in Table A1 is fitted to the interface connector panel on this iQ Interface Module:

Connector name/number	Connector type	Figure A1 reference
Tool connector J2	25 way D-type F	1
Tool EMS connector J1	AMP CPC 206430-1-F	2
Pump EMS connector	XLR-6	3

Table A1 - Connector types

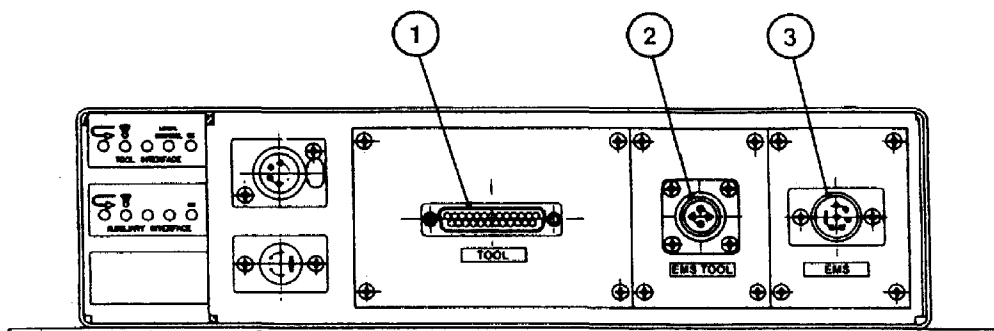

1. Tool J2
2. Tool EMS J1
3. Pump EMS

Figure A1 - Interface connector panel

4 Use of connector pins

The signals available on the connectors are shown in Table A2 and Table A3. Refer to the appropriate sections of this instruction manual for electrical data for the signals available on the Tool Interface Card connectors and for information on the use of the signals.

Pin numbers	Signal	Destination/Source
1 and 14	Pumps not in alarm volt-free status output	TIC, CH5 PL7
2 and 15	Pumps running volt-free status output	TIC, CH3 PL8
3 and 16	Pumps not in warning and gas flow not in warning volt-free status output	TIC, CH4 PL8 TIC, CH6 PL7
10 and 23	Both pumps on a.c./d.c. control input	TIC, CH3 PL12

Table A2 - Tool J2 connector signals

Pin numbers	Signal	Destination/Source
1 and 2	EMS output to tool normally closed volt-free status output	EMS

Table A3 - Tool EMS J1 connector signals

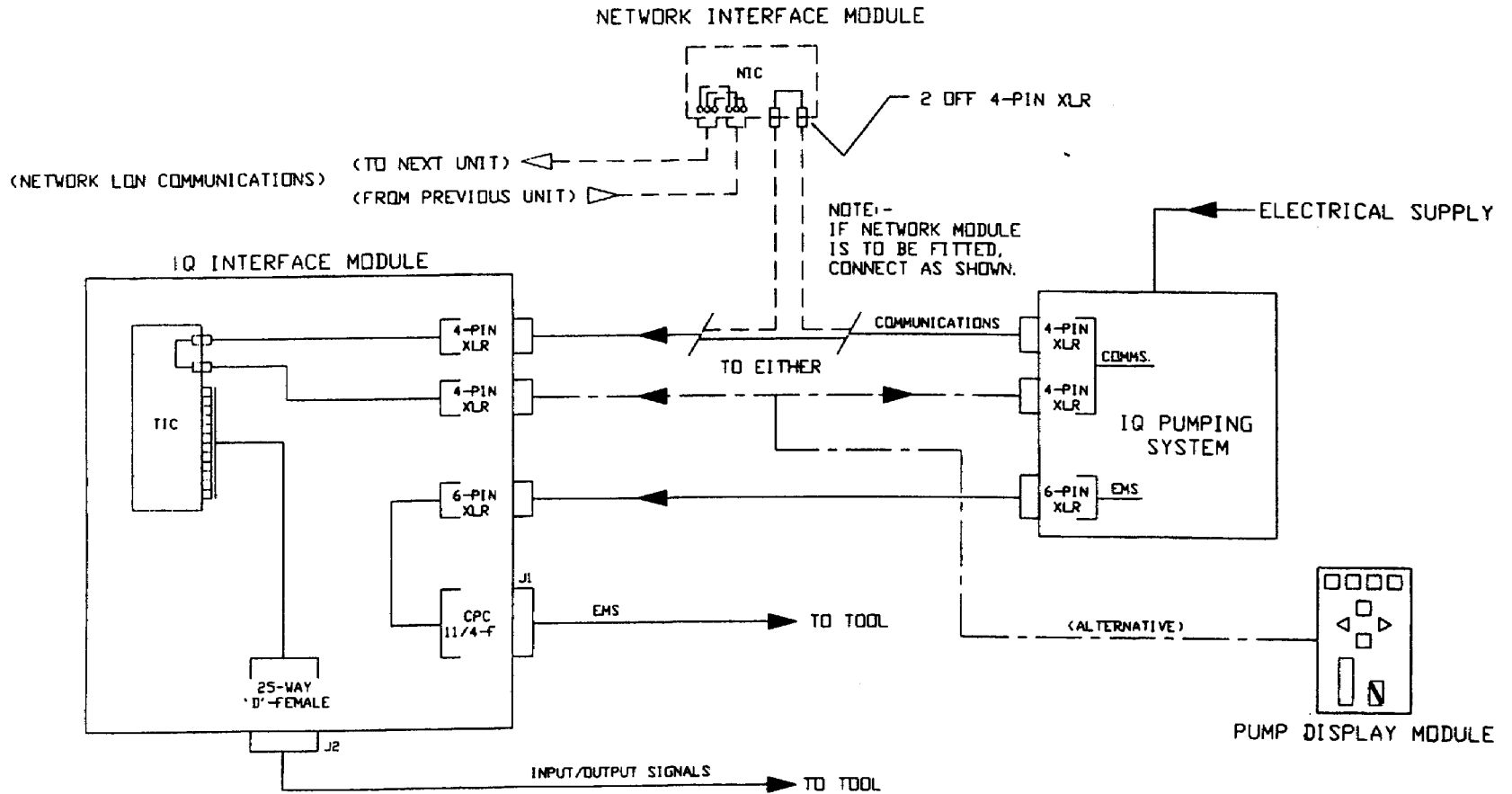

Figure A2 - Schematic diagram of the electrical connections

iQ Interface Module - Item Number A528-44-481

1 Introduction

This Amendment describes the details of this iQ Interface Module

2 Items supplied

Qty	Description	Check <input type="checkbox"/>
1	iQ Interface module	<input type="checkbox"/>
1	Instructions - iQ Interface module	<input type="checkbox"/>
1	Instruction amendment	<input type="checkbox"/>
1	Cable assembly - 5m (4 way - XLR)	<input type="checkbox"/>
1	iQDP Terminator plug (4 way - XLR)	<input type="checkbox"/>
1	Cable assembly - 5m (6 way - XLR)	<input type="checkbox"/>
1	Cable assembly - Amphenol 11/4 to 13/9	<input type="checkbox"/>
1	Plug housing 25-way D-connector	<input type="checkbox"/>
1	Hood 25-way D-connector	<input type="checkbox"/>
8	Contact pin D-connector	<input type="checkbox"/>
1	Plug - Amphenol 11/4	<input type="checkbox"/>
1	Clamp - size 11	<input type="checkbox"/>
2	Contact pin - Amphenol	<input type="checkbox"/>
1	Plug - Amphenol 13/9	<input type="checkbox"/>
1	Clamp - size 13	<input type="checkbox"/>
6	Contact socket - Amphenol	<input type="checkbox"/>

Table A1 - Checklist of items

3 Cards fitted

The following Interface Cards are fitted in this iQ Interface Module:

- TIC (Tool Interface Card).
- AIC (Auxiliary Interface Card).

4 Connectors

The connectors in Table A2 are fitted to the interface connector panel on this iQ Interface Module:

Connector name/number	Connector type	Figure A1 reference
Tool connector J2	25 way D-type F	1
Pump EMS connector	XLR-6	2
Tool EMS connector J1	AMP CPC 206430-1-F	3
Process valve	CPC 13/9-M	4

Table A2 - Connector types

5 Use of connector pins

The signals available on the connectors are shown in Table A3 and Table A5. Refer to the appropriate sections of this instruction manual for electrical data for the signals available on the Tool Interface Card connectors and for information on the use of the signals.

Pin numbers	Signal	Destination/Source
1 and 14	Pumps not in alarm volt-free status output	TIC, CH5 PL7
2 and 15	Pumps running volt-free status output	TIC, CH3 PL8
3 and 16	Pumps not in warning and gas flow not in warning volt-free status output	TIC, CH4 PL8 TIC, CH6 PL7
10 and 23	Both pumps on a.c./d.c. control input	TIC, CH3 PL12

Table A3 - Tool J2 connector signals

Pin numbers	Signal	Destination/Source
1 and 2	EMS output to tool normally closed volt-free status output	EMS

Table A4 - Tool EMS J1 connector signals

Pin numbers	Signal	Destination/Source
1 and 2	Valve closed volt-free status input (from valve)	AIC, CH1 PL17
3 and 4	Valve open volt-free status input (from valve)	AIC, CH2 PL17
7 and 9	Open/close valve 24 V a.c. control input (to valve)	AIC, CH1 PL9

Table A5 - Process valve connector signals

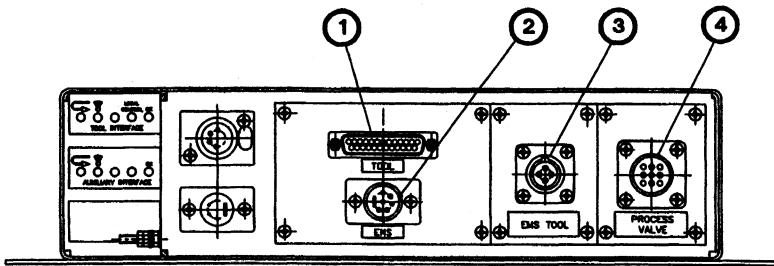

1. Tool J2
2. Pump EMS
3. Tool EMS J1
4. Process valve

Figure A1 - Interface connector panel

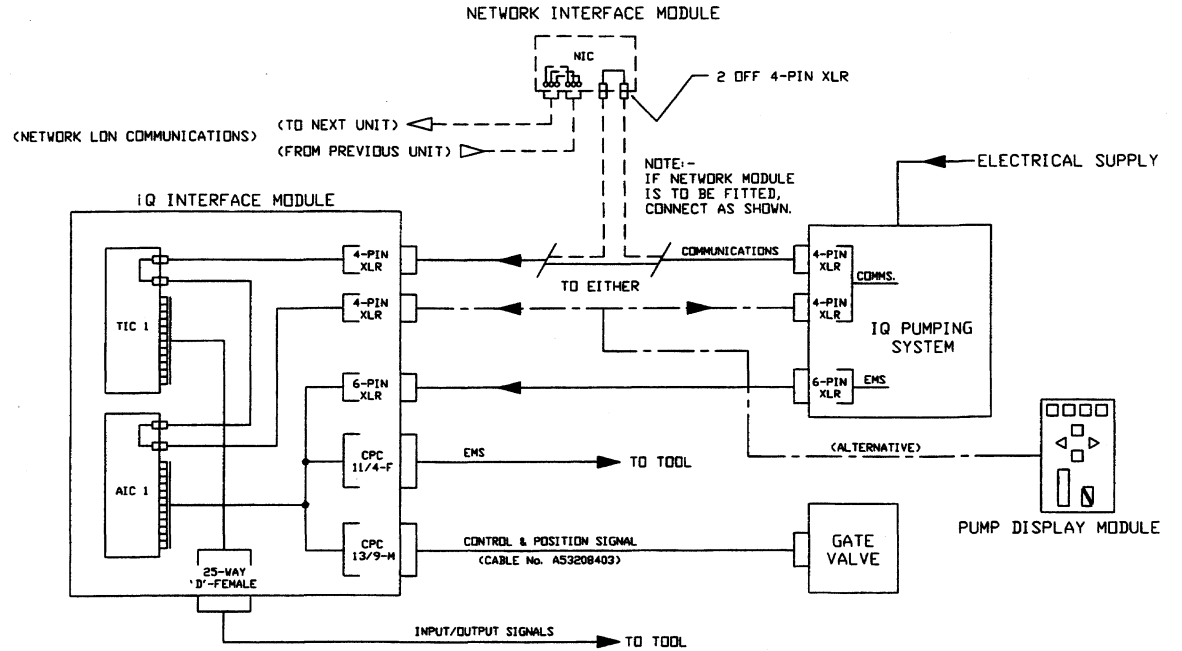

Notes

1. The Pump Display Module can be used with the IQ pumping system on its own without external communication.
2. Vacant XLR-4 pin communications connectors must have terminator plugs fitted.

Figure A2 - Schematic diagram of the electrical connections

iQ Interface Module - Item Number A528-44-484

1 Introduction

This Amendment describes the details of this iQ Interface Module.

2 Mechanical data

This iQ Interface Module is larger than the standard iQ Interface Module and its depth is 166.4 mm, not 86.5 mm as specified in the instruction manual.

The actual mass of this iQ Interface Module is specified on a rating plate on the iQ Interface Module.

3 Cards fitted

The following Interface Cards are fitted in this iQ Interface Module:

- TIC1 (Tool Interface Card for the process pump)
- TIC2 (Tool Interface Card for the loadlock pump)

4 Connectors

The connectors in Table A1 are fitted to the interface connector panel on this iQ Interface Module:

Connector name/number	Connector type	Figure A1 reference
70J2 Tool	D.-conn-37 way-F	1
70J3 Gas box disable	CPC 11/4-M	2
70J1 Tool EMS	CPC 13/9-M	3

Table A1 - Connector types

5

Use of connector pins

The signals available on the connectors are shown in Tables A2 to A4. Refer to the appropriate sections of this instruction manual for electrical data for the signals available on the Tool Interface Card connectors and for information on the use of the signals.

Pin numbers	Signal	Destination/ Source
1 and 20	Process pump not in warning volt-free status output	TIC1, CH4 PL8
2 and 21	Process pump running volt-free status output	TIC1, CH3 PL8
3 and 22	Internal link	
5 and 24	Internal link	
10 and 29	Loadlock pump not in warning volt-free status output	TIC2, CH4 PL8
11 and 30	Loadlock pump running volt-free status output	TIC2, CH3 PL8
15 and 34	Gas box disable input	70J3 pins 3 and 4
36 and 37	Gas flow not in warning volt-free status output	TIC1, CH6 PL7

Table A2 - 70J2 Tool connector signals

Pin numbers	Signal	Destination/ Source
1 and 2	Linked	-
3 and 4	Gas box disable from tool	70J2 pins 15 and 34

Table A3 - 70J3 Gas box disable connector signals

Pin numbers	Signal	Destination/ Source
1 and 2	EMS volt-free output to tool closed in normal operation	EMS
3 and 4	EMS volt-free input from tool closed in normal operation	EMS
5 and 6	Process pump running volt-free status status output	TIC1, CH1 PL9

Table A4 - 70J1 Tool EMS connector signals

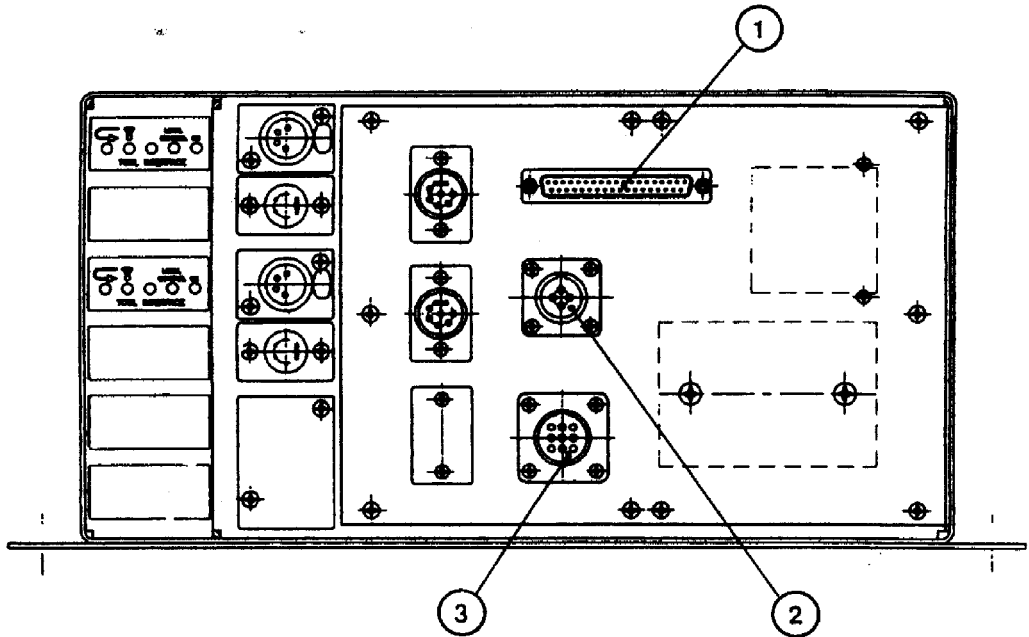

1. 70J2 Tool connector
2. 70J3 Gas box disable
3. 70J1 EMS

Figure A1 - Interface connector panel

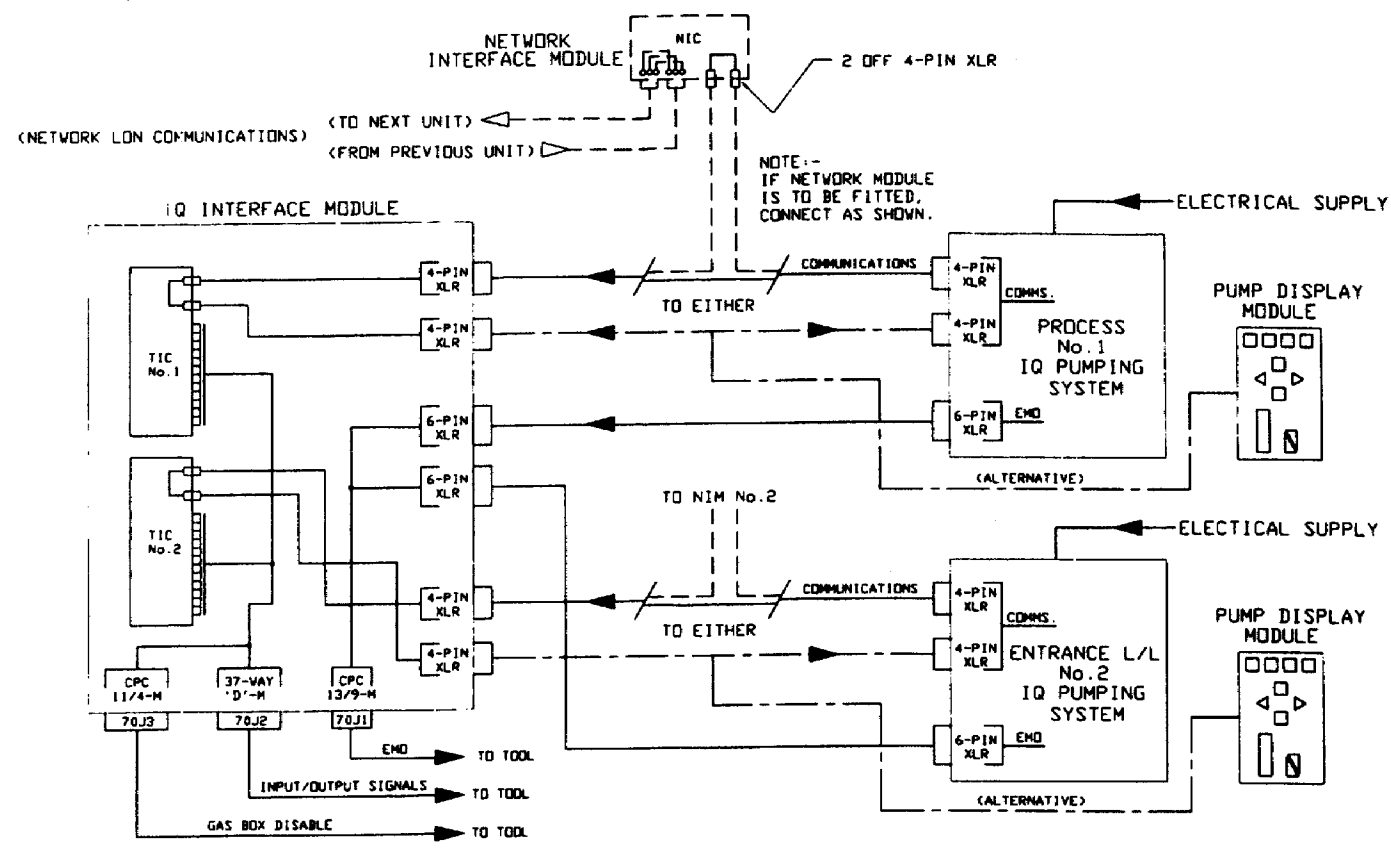

- NOTES:-
1. PUMP DISPLAY MODULE CAN BE USED WITH THE IQ PUMPING SYSTEM ON ITS OWN WITHOUT EXTERNAL COMMUNICATION.
 2. VACANT XLR-4 PIN COMMUNICATIONS CONNECTORS MUST HAVE TERMINATOR PLUG FITTED.

Figure A2 - Schematic diagram of the electrical connections

iQ Interface Module - Item Number A528-44-485

1 Introduction

This Amendment describes the details of this iQ Interface Module.

2 Mechanical data

This iQ Interface Module is larger than the standard iQ Interface Module and its depth is 166.4 mm, not 86.5 mm as specified in the instruction manual.

The actual mass of this iQ Interface Module is specified on a rating plate on the iQ Interface Module.

3 Cards fitted

The following Interface Cards are fitted in this iQ Interface Module:

- TIC1 (Tool Interface Card for the process pump)
- TIC2 (Tool Interface Card for the process loadlock pump)
- TIC3 (Tool Interface Card for the entrance loadlock pump)

4 Connectors

Note: If the DSQ stripper tool pump is not in use, you must fit the dummy 6-way neutrix plug supplied in the relevant EMO connector.

The connectors in Table A1 are fitted to the interface connector panel on this iQ Interface Module:

Connector name/number	Connector type	Figure A1 reference
70J2 Tool connector	D.-conn-37 way-F	1
70J3 Gas box disable	CPC 11/4-M	2
70J1 EMO	CPC 13/9-M	3

Table A1 - Connector types

5

Use of connector pins

The signals available on the connectors are shown in Tables A2 to A4. Refer to the appropriate sections of this instruction manual for electrical data for the signals available on the Tool Interface Card connectors and for information on the use of the signals.

Pin numbers	Signal	Destination/ Source
1 and 20	Process pumps not in warning volt-free status output	TIC1, CH4 PL8
2 and 21	Process pump on volt-free status output	TIC1, CH3 PL8
3 and 22	Linked	-
5 and 24	Linked	-
10 and 29	Entrance loadlock pump not in warning volt-free status output	TIC2, CH4 PL8
11 and 30	Entrance loadlock both pumps on volt-free status output	TIC2, CH3 PL8
12 and 31	Process loadlock pump not in warning volt-free status output	TIC3, CH4 PL8
13 and 32	Process loadlock pumps on volt-free status output	TIC3, CH3 PL8
15 and 34	Gas box disable input from tool	70J3 process pump connector
36 and 37	Process pump gas flow not in warning volt-free status output	TIC1, CH6 PL7

Table A2 - 70J2 Tool connector signals

Pin numbers	Signal	Destination/ Source
1 and 2	Linked	
3 and 4	Gas box disable output	70J2 pins 15 and 34

Table A3 - 70J3 (Gas box disable) connector signals

Pin numbers	Signal	Destination/ Source
1 and 2	EMO output to tool (N/C)	-
3 and 4	EMO input from tool (N/C)	-
5 and 6	Process pump running volt-free status output	TIC1, CH1 PL9

Table A4 - 70J1 EMO connector signals

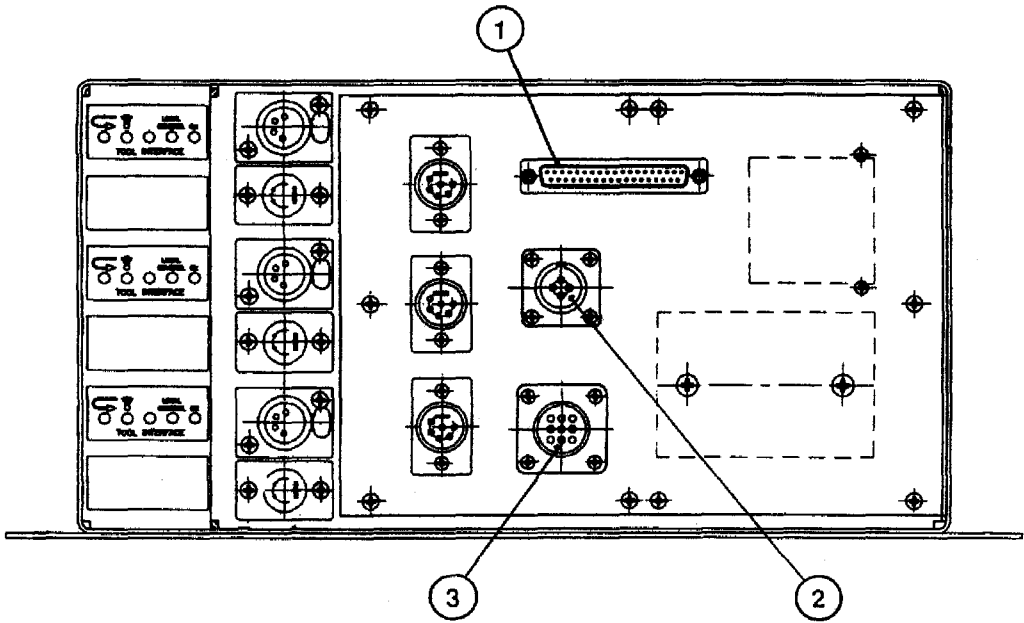

1. 70J2 Tool connector
2. 70J3 Gas box disable connector
3. 70J1 EMO connector

Figure A1 - Interface connector panel

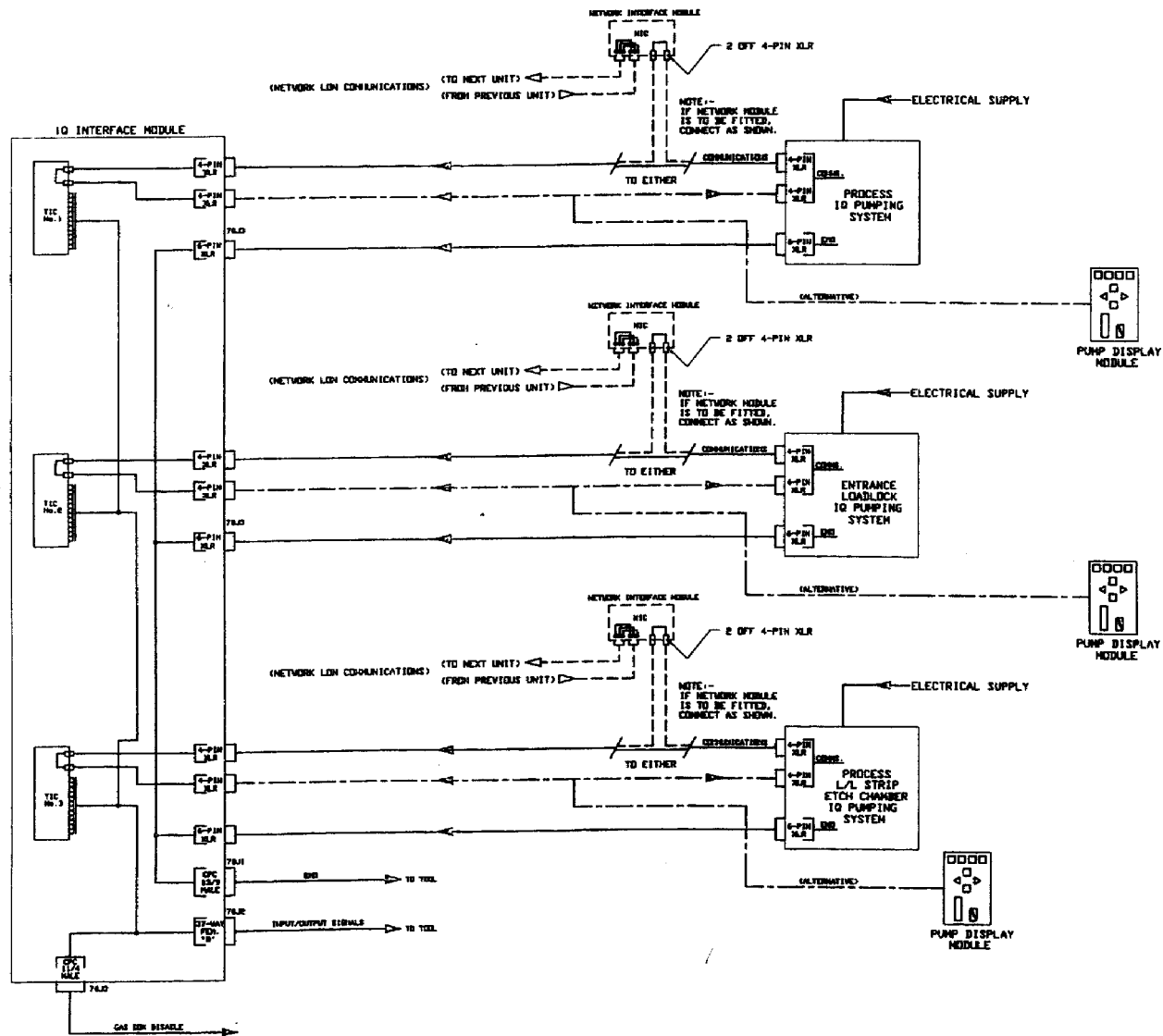

- NOTES:-
1. PUMP DISPLAY MODULE CAN BE USED WITH THE IO PUMPING SYSTEM ON ITS OWN WITHOUT EXTERNAL COMMUNICATION.
 2. VACANT XLR-4 PIN COMMUNICATIONS CONNECTORS MUST HAVE TERMINATOR PLUG FITTED.

Figure A2 - Schematic diagram of the electrical connections

iQ Interface Module - Item Number A528-44-492

1 Introduction

This Amendment describes the details of this iQ Interface Module

2 Cards fitted

The following Interface Cards are fitted in this iQ Interface Module:

- TIC (Tool Interface Card)
- AIC (Auxiliary Interface Card)
- NIC (Network Interface Card)

3 Connectors

The connectors in Table A1 are fitted to the interface connector panel on this iQ Interface Module:

Connector name/number	Connector type	Figure A1 reference
MCM/Tool	25-way D.-Conn.-F	1
Process	25-way D.-Conn.-M	2
Network	9-way D.-Conn.-F	3
Network	9-way D.-Conn.-F	4
Gate Valve	CPC 13/9-M	5

Table A1 - Connector types

Use of connector pins

The signals available on the connectors are shown in Tables A2 and A6. Refer to the appropriate sections of this instruction manual for electrical data for the signals available on the Tool Interface Card and Auxiliary Interface Card connectors and for information on the use of the signals.

Pin numbers	Signal	Destination/ Source
1 and 14	Set outputs for tool volt-free control input	TIC, CH8 PL14
2 and 15	Process On volt-free control input	TIC, CH4 PL16
3 and 16	Open valve (AIM) volt-free control input	TIC, CH5 PL15
4 and 17	Run til crash volt-free control input	TIC, CH6 PL15
5 and 18	Auto shutdown volt-free control input	TIC, CH7 PL14
6 and 7	Both pumps on 24 V a.c./d.c. control input	TIC, CH3 PL12
8 and 20	Pumps running volt-free status output	TIC, CH3 PL8
9 and 21	Pumps not in warning (alternative tool - excludes exhaust pressure warning) volt-free status output	TIC, CH4 PL8
10 and 22	Pumps not in alarm volt-free status output	TIC, CH5 PL7
11 and 23	Gas flow not in warning volt-free status output	TIC, CH6 PL7
12 and 24	Final valve open (alternative tool - waterflow not in warning) volt-free status output	TIC, CH7 PL6
13 and 25	Exhaust pressure not in alarm volt-free status output	TIC, CH8 PL6

Table A2 - Process connector signals

Pin numbers	Signal	Destination/ Source
2 and 15	Loadlock pump not in alarm volt-free status output (to tool)	AIC, CH4 PL8
3 and 16	Loadlock pump not in warning volt-free status output (to tool)	AIC, CH5 PL7
4 and 17	Loadlock pump running volt-free status output (to tool)	AIC, CH6 PL7
6 and 7	Loadlock pump on volt-free control input (from tool)	AIC, CH8 PL10
10 and 22	Loadlock pump on volt-free status output (to pump)	AIC, CH3 PL8
11 and 23	Loadlock pump running volt-free status input (from pump)	AIC, CH7 PL14
12 and 24	Loadlock pump not in warning volt-free status input (from pump)	AIC, CH6 PL15
13 and 25	Loadlock pump not in alarm volt-free status input (from pump)	AIC, CH5 PL15

Table A3 - MCM/Tool connector signals

Pin numbers	Signal	Destination/Source
1	Data A	NIC, TB2 pin1
4	Data B	NIC, TB2 pin2
7	Screen	NIC, TB2 pin3

Table A4 - Network connector signals

Pin numbers	Signal	Destination/Source
1	Data A	NIC, TB1 pin 1
4	Data B	NIC, TB1 pin 2
7	Screen	NIC, TB1 pin 3

Table A5 - Network connector signals

Pin numbers	Signal	Destination/Source
1 and 2	Valve closed volt-free status input (from valve)	AIC, CH1 PL17
3 and 4	Valve open volt-free status input (from valve)	AIC, CH2 PL17
5 and 6	Open valve volt-free control output (to valve)	AIC, CH1 PL9

Table A6 - Valve connector signals

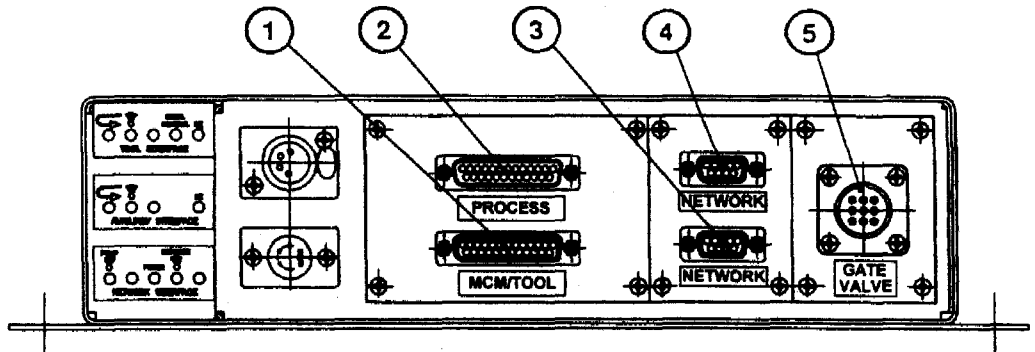

- 1. MCM/Tool connector
- 2. Process connector
- 3. Network connector
- 4. Network connector
- 5. Gate valve connector

Figure A1 - Interface connector panel

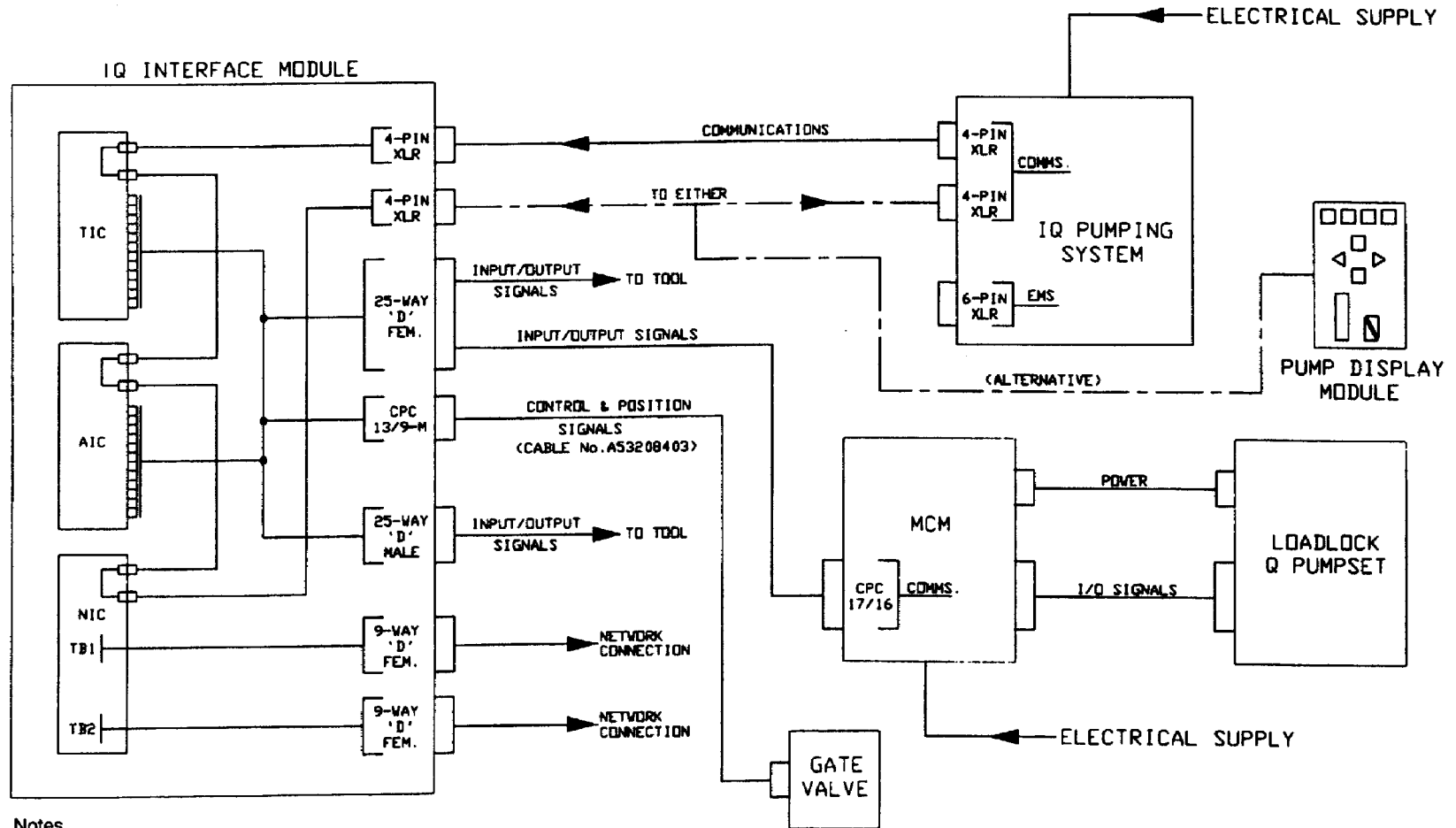

Notes

1. The Pump Display Module can be used with the iQ pumping system on its own without external communication.
2. Vacant XLR-4 pin communications connectors must have terminator plugs fitted.

Figure A2 - Schematic diagram of the electrical connections

iQ Interface Module - Item Number A528-44-514

1 Introduction

This Amendment describes the details of this iQ Interface Module.

2 Mechanical data

This iQ Interface Module is larger than the standard iQ Interface Module and its depth is 166.4 mm, not 86.5 mm as specified in the instruction manual.

The mass of this iQ Interface Module is specified on a rating plate on the iQ Interface Module.

3 Cards fitted

The following Interface Cards fitted in this iQ Interface Module:

- TIC (Tool Interface Card)

4 Connectors

The connectors in Table A1 are fitted to the interface connector panel on this iQ Interface Module:

Connector name/number	Connector type	Figure A1 reference
EMS	XLR-6	1
EMS Tool/J1	CPC 11/4-F	2
EMS Tool/J2	CPC 11/4-F	3
N ₂ /J4	D.-conn-9 way-M	4
Tool/J3	D.-conn-25 way-M	5

Table A1 - Connector types

5

Use of connector pins

The signals available on the connectors are shown in Tables A2 to A5. Refer to the appropriate sections of this instruction manual for electrical data for the signals available on the Tool Interface Card connectors and for information on the use of the signals.

Pin numbers	Signal	Destination/ Source
1 and 2	EMS output to tool (closed in normal operation)	EMS chain
3 and 4	24 V a.c. pump enable (from tool)	RL1

Table A2 - EMS Tool/J1 connector signals

Pin numbers	Signal	Destination/ Source
1 and 2	EMS output to tool (closed in normal operation)	EMS chain
3 and 4	24 V a.c. pump enable (from tool)	RL1

Table A3 - EMS Tool/J2 connector signals

Pin numbers	Signal	Destination/ Source
2 and 6	N ₂ flow warning (to tool)	TIC, CH6 RL2
3 and 7	Foreline at vacuum (to tool)	TIC, CH1 PL9 T1
4 and 8	Linked	-

Table A4 - N₂/ J4 connector signals

Pin numbers	Signal	Destination/ Source
1 and 14	Exhaust pressure/temperature not in alarm volt-free status output	TIC, CH5 PL7 RL3
2 and 15	Exhaust pressure/temperature not in alarm volt-free status output	TIC, CH5 PL7 RL3
3 and 16	Pump running volt-free status output	TIC, CH3 PL8
4 and 17	N ₂ flow warning volt-free status output	TIC, CH6 PL7 RL2
5 and 18	N ₂ flow warning volt-free status output	TIC, CH6 PL7 RL2
6 and 19	Pump not in warning volt-free status output (excluding exhaust pressure warning)	TIC, CH4 PL8
7 and 20	Exhaust pressure not in warning volt-free status output	TIC, CH8 PL6
10 and 23	Pump on 24 V a.c./d.c. control input	TIC, CH3 PL12

Table A5 - Tool/J3 connector signals

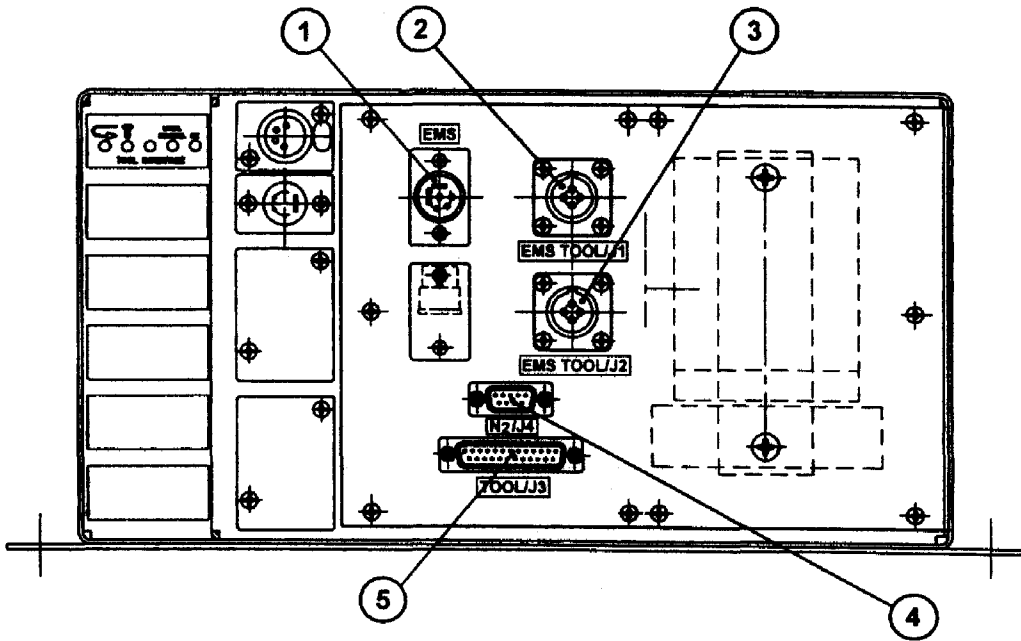

- | | |
|----------------|-----------------------|
| 1. EMS | 2. EMS Tool/J1 |
| 3. EMS Tool/J2 | 4. N ₂ /J4 |
| 5. Tool/J3 | |

Figure A1 - Interface connector panel

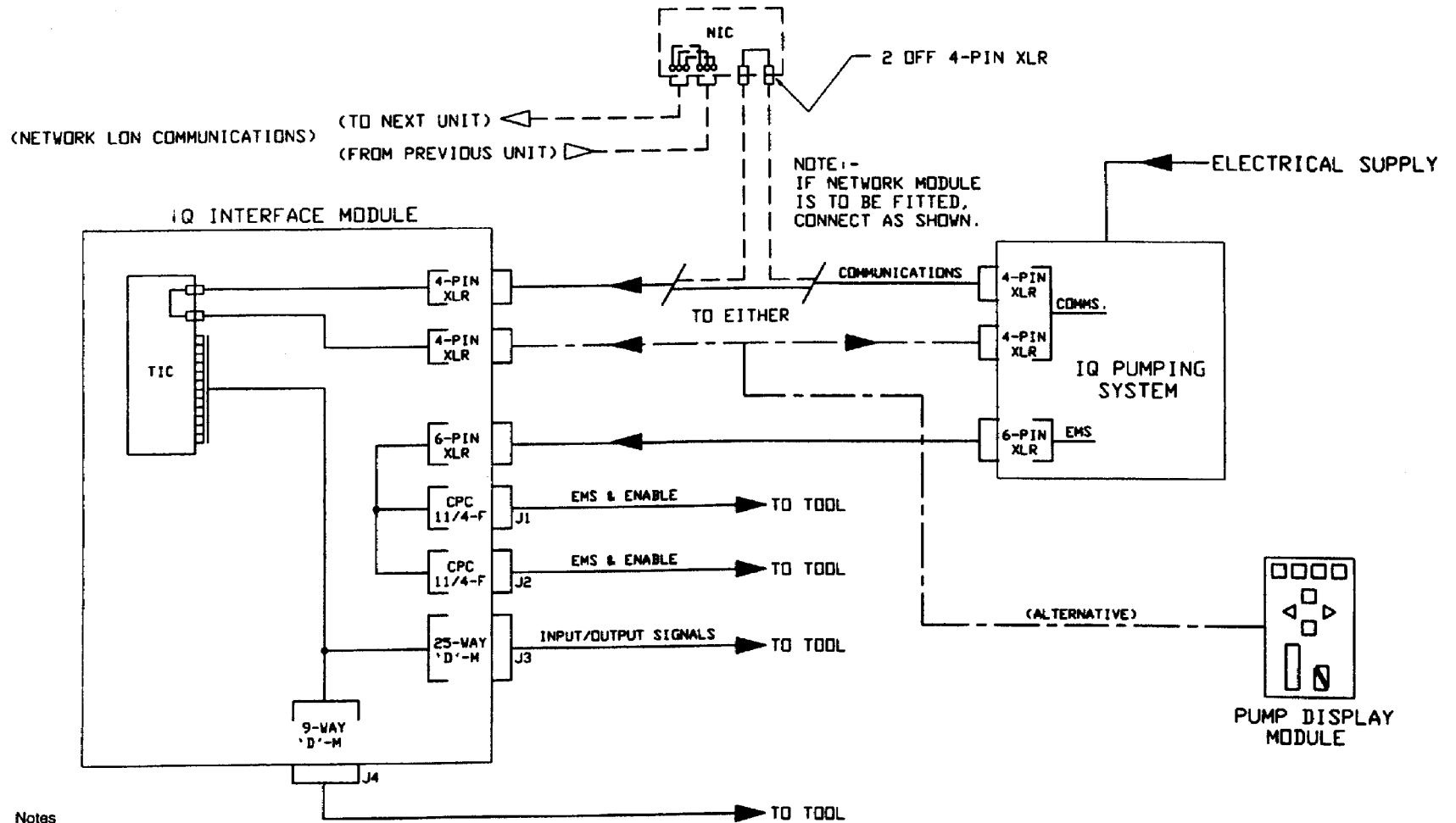

Notes

1. The Pump Display Module can be used with the iQ pumping system on its own without external communication.
2. Vacant XLR-4 pin communications connectors must have terminator plugs fitted.

Figure A2 - Schematic diagram of the electrical connections

iQ Interface Module - Item Number A528-44-524

1 Introduction

This Amendment describes the details of this iQ Interface Module.

2 Cards fitted

The following Interface Card is fitted in this iQ Interface Module:

- Tool Interface Card (TIC).

3 Connectors

The connectors in Table A1 are fitted to the interface connector panel on this iQ Interface Module:

Connector name/number	Connector type	Figure A1 reference
Valve	CPC 11/4-M	1
J1	CPC 11/4-F	2
J2	CPC 11/4-F	3
EMO	XLR-6	4

Table A1 - Connector types

4

Use of connector pins

The signals available on the connectors are shown in Tables A2 to A4. Refer to the appropriate sections of this instruction manual for electrical data for the signals available on the Tool Interface Card connectors and for information on the use of the signals.

Pin numbers	Signal	Destination/ Source
3 and 4	iQDP pump running volt-free status output	TIC, CH1 PL9

Table A2 - Valve connector signals

Pin numbers	Signal	Destination/ Source
1 and 2	EMO N/C output	Tool EMO chain
3 and 4	24 V pump enable input from tool	Tool

Table A3 - J1 connector signals

Pin numbers	Signal	Destination/ Source
1 and 2	EMO N/C output	Tool EMO chain
3 and 4	24 V pump enable input from tool	Tool

Table A4 - J2 connector signals

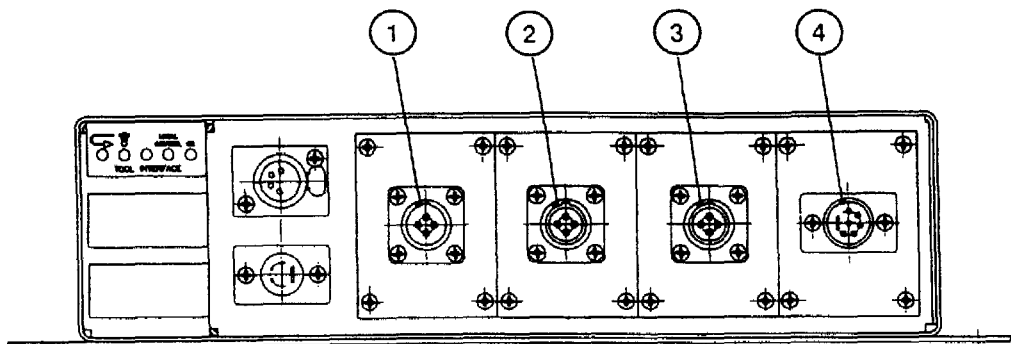

- 1. Valve connector
- 2. J1 connector
- 3. J2 connector
- 4. EMO connector

Figure A1 - Interface connector panel

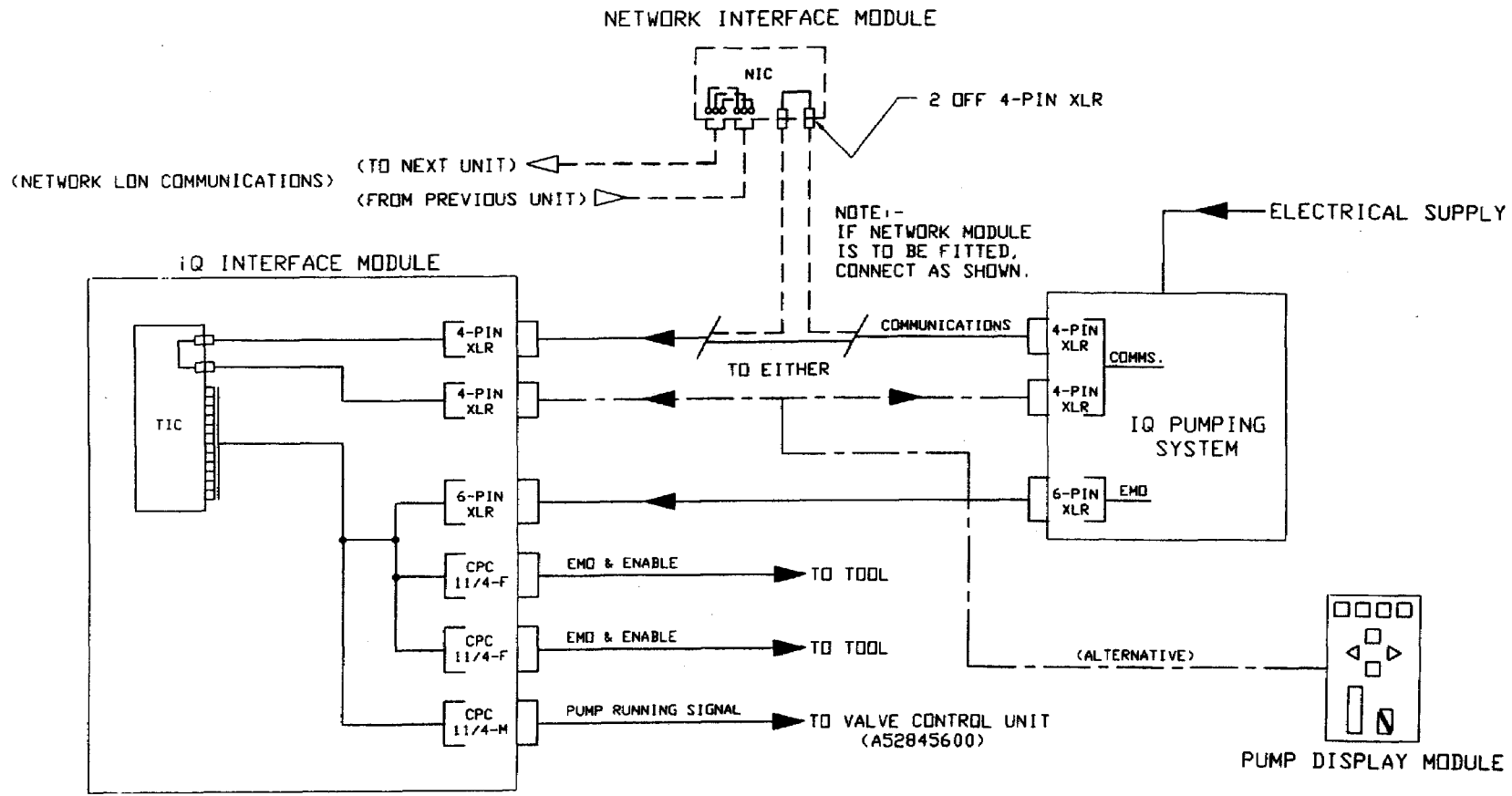

NOTES:-

1. PUMP DISPLAY MODULE CAN BE USED WITH THE IQ PUMPING SYSTEM ON ITS OWN WITHOUT EXTERNAL COMMUNICATION.
2. VACANT XLR-4 PIN COMMUNICATIONS CONNECTORS MUST HAVE TERMINATOR PLUG FITTED.

Figure A2 - Schematic diagram of the electrical connections

Declaration of Conformity

We, Edwards High Vacuum International,
Manor Royal,
Crawley,
West Sussex RH10 2LW, UK

declare under our sole responsibility that the product(s)

iQ Interface Module

A52844400 TO A52844599 inclusive

to which this declaration relates is in conformity with the following standard(s)
or other normative document(s)

IEC 204-1 Electrical Safety ; Machines

IEC 1010-1 Electrical Safety ; Laboratory

EN 50081-1 EMC Emissions ; Light Industrial

EN 50082-2 EMC Immunity ; Heavy Industrial

following the provisions of

Low Voltage (Electrical Safety) 73-23- EEC

Electromechanical Compatibility (EMC) 89-336-EEC

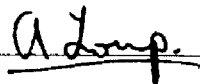

Dr A. Troupe, Director of Technology

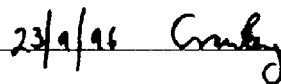

Date and Place

This product has been manufactured under a quality system registered to ISO9001

CONTENTS

Section	Title	Page
1	INTRODUCTION	1
1.1	Scope and definitions	1
1.2	General description	1
1.3	Connectors	2
1.4	The Tool Interface Card	2
1.5	The Auxiliary Interface Card	2
2	TECHNICAL DATA	4
2.1	Mechanical data	4
2.2	Electrical data (Tool Interface Card and Auxiliary Interface Card)	4
2.3	Electrical connectors	4
3	INSTALLATION	6
3.1	Unpack and inspect	6
3.2	Fit the iQ Interface Module	6
3.3	Connect to your emergency stop equipment (if necessary)	6
3.4	Connect the iQ Interface Module to the iQ pumping system and to another module (optional)	7
3.5	Connect the iQ Interface Module to other control equipment	7
4	OPERATION	8
4.1	Introduction	8
4.2	Tool Interface Card	8
4.2.1	Inputs and outputs	8
4.2.2	Tool type selection	10
4.2.3	Use of the buttons and LEDs	10
4.2.4	Setpoints store	10
4.2.5	Take and release control	10
4.3	Auxiliary Interface Card	11
4.3.1	Inputs and outputs	11
4.3.2	Introduction to gate valve operation	12
4.3.3	Gate valve operation: normal pumping system operation	12
4.3.4	Emergency shut-down/emergency stop	13
5	MAINTENANCE	13
6	STORAGE AND DISPOSAL	13
6.1	Storage	13
6.2	Disposal	13
7	SPARES AND ACCESSORIES	14
7.1	Introduction	14
7.2	Spares	14
	RETURN OF EDWARDS EQUIPMENT	

Illustrations

Figure	Title	Page
1	Components of the iQ Interface Module	3
2	Dimensions (mm)	5

Tables

Table	Title	Page
1	Checklist of items	6
2	Tool Interface Card inputs	8
3	Tool Interface Card outputs	9
4	Tool Interface Card outputs set and reset definitions	9
5	Auxiliary Interface Card inputs	11
6	Auxiliary Interface Card outputs	12

1 INTRODUCTION

1.1 Scope and definitions

This manual provides installation, operation and maintenance instructions for the Edwards iQ Interface Module. You must use the iQ Interface Module as specified in this manual.

Read this manual before you install and use the iQ Interface Module. Important safety information is shown as WARNING instructions; you must obey these instructions. The use of WARNINGS is defined below.

WARNING

Warnings are given where failure to observe the instruction could result in injury or death to people.

The following symbol appears on the iQ Interface Module:



Caution - refer to accompanying documentation.

The units used throughout this manual conform to the SI international system of units of measurement.

1.2 General description

The iQ Interface Module is designed for use with the Edwards iQ dry pumping system and allows you to connect the pumping system to other equipment (for example, your Process Tool or other control equipment). The iQ Interface Module is an enclosure which contains one to six Interface Cards. The types of card which can be fitted are as follows:

- Tool Interface Card: see Section 1.4.
- Auxiliary Interface Card: see Section 1.5.

The cards fitted to your iQ Interface Module are described in the Amendment at the front of this manual.

1.3 Connectors

Refer to Figure 1. The iQ Interface Module is connected to the iQ system through the system connector (3) on the bottom of the iQ Interface Module. If required, the module connector (2) is used to connect the iQ Interface Module to other iQ system modules (for example, a Pump Display Module).

Your iQ Interface Module is supplied with a number of connectors fitted to the interface connector panels (1). The pins on the connectors are connected to the inputs and outputs of the Interface Cards fitted to the iQ Interface Module. You will use the connectors as described in the Amendment at the front of this manual.

1.4 The Tool Interface Card

The Tool Interface Card allows you to control the operation of and to monitor the status of the iQ system through your Process Tool.

Refer to Section 4.2 for details of how to use the Tool Interface Card.

1.5 The Auxiliary Interface Card

The Auxiliary Interface Card allows you to control pumping system components which are not controlled through the iQ network system; for example, components such as :

- A gate valve.
- A load-lock pump, controlled through a Motor Control Module.

Refer to Section 4.3 for details of how to use the Auxiliary Interface Card.

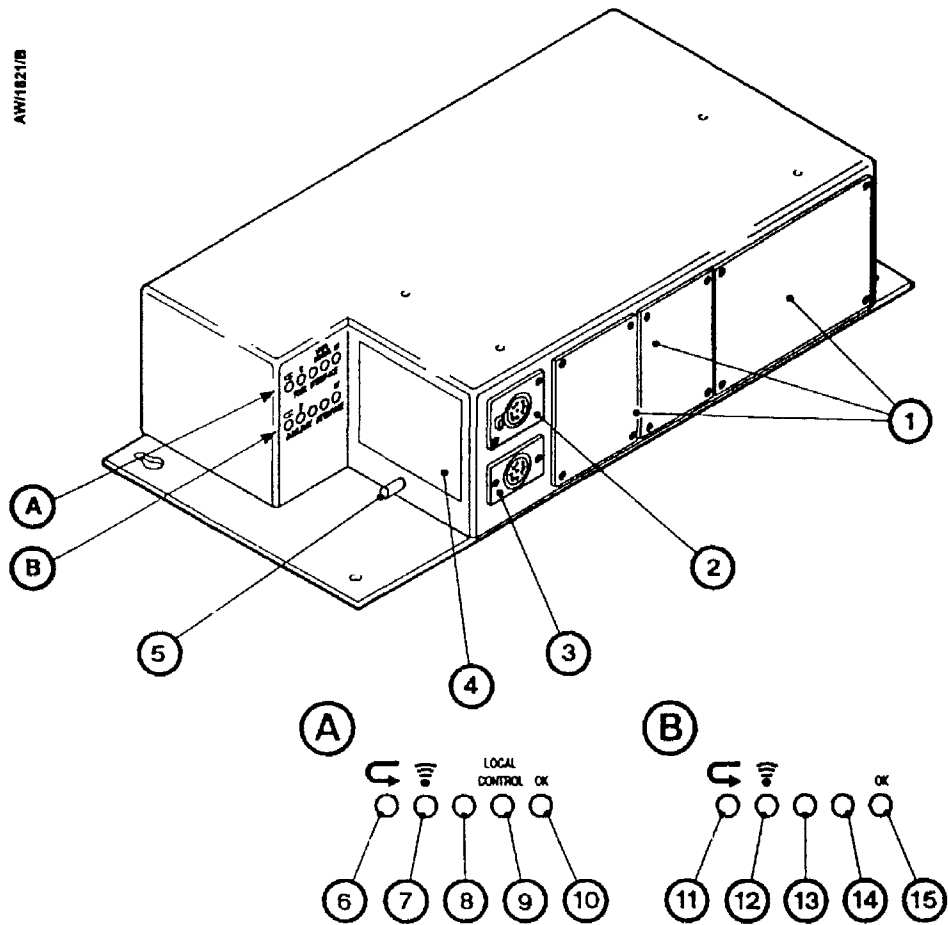

- A Tool Interface Card LEDs and buttons
 B Auxiliary Interface Card LEDs and buttons

- | | |
|---|---|
| 1. Interface connector panel* | 9. Tool Interface Card local control LED |
| 2. Module connector (to other iQ modules) | 10. Tool Interface Card OK LED |
| 3. System connector (to iQ system) | 11. Auxiliary Interface Card default button |
| 4. Rating plate | 12. Auxiliary Interface Card service button |
| 5. Earth (ground) stud | 13. Auxiliary Interface Card service LED |
| 6. Tool Interface Card default button | 14. Not used |
| 7. Tool Interface Card service button | 15. Auxiliary Interface Card OK LED |
| 8. Tool Interface Card service LED | |

* The interface connector panel is shown above as one half-panel and two-quarter-panels, but may be different on your iQ Interface Module. Refer to the illustration in the Amendment at the front of this manual for the configuration of the interface connector panel on your iQ Interface Module.

Figure 1 - Components of the iQ Interface Module

2 TECHNICAL DATA

2.1 Mechanical data

Dimensions	See Figure 2
Maximum mass	Approximately 6 kg*

* The exact mass of the iQ Interface Module depends on the Interface Cards and the connectors fitted to the iQ Interface Module; refer to the rating plate on the iQ Interface Module (Figure 1, item 4) for the mass of your iQ Interface Module.

2.2 Electrical data (Tool Interface Card and Auxiliary Interface Card)

Inputs

Number	8
Type 1	a.c./d.c. input† signal
High input voltage threshold	> 20 V
Low input voltage threshold	< 5 V
Type 2	Volt-free (dry) contacts
External contact rating	24 V

Outputs

Number	8
Type	Changeover relays, with normally open and normally closed contacts
Rating	1 A, 24 V

2.3 Electrical connectors

Note: Other connectors are described in the Amendment at the front of this manual.

iQ system and module connectors	XLR type 4-way
Emergency stop connector †	XLR type 6-way

† Optional: refer to the Amendment at the front of this manual.

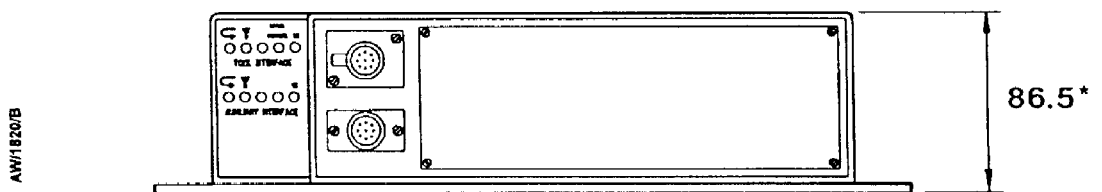
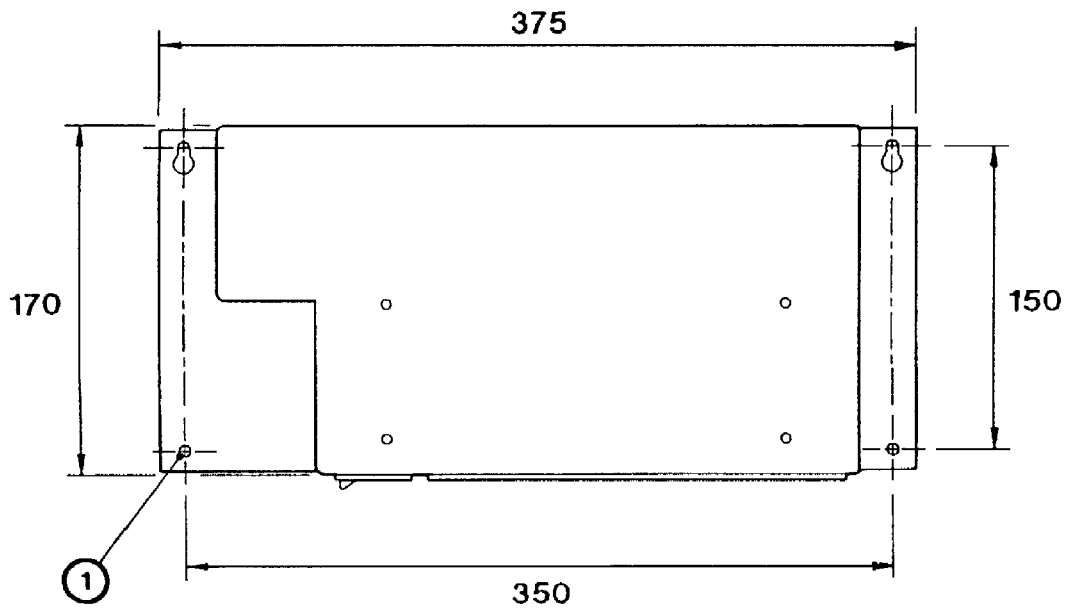

1. Fixing hole: $\varnothing 5$

* This dimension depends on the number of Interface Cards fitted in the iQ Interface Module: refer to the Amendment at the front of this manual.

Figure 2 - Dimensions (mm)

3 INSTALLATION

3.1 Unpack and inspect

Remove all packing materials and inspect the iQ Interface Module. If the iQ Interface Module is damaged, notify your supplier and the carrier in writing within three days; state the Item Number of the iQ Interface Module together with your order number and your supplier's invoice number. Retain all the packing materials for inspection. Do not use the iQ Interface Module if it is damaged.

Check that you have received the items listed in Table 1. If any item is missing, notify your supplier within three days. If the iQ Interface Module is not to be used immediately, replace it in its protective packaging. Store the iQ Interface Module in suitable conditions, as described in Section 6.

Qty	Description	Check (✓)
1	iQ Interface Module	<input type="checkbox"/>
†	iQ emergency stop cable ▲	<input type="checkbox"/>
†	iQ connector cable	<input type="checkbox"/>
†	Terminator plug	<input type="checkbox"/>
*	Connector mating halves *	<input type="checkbox"/>

† You will require one cable/plug for each iQ system connected to the iQ Interface Module.

▲ Emergency stop cable(s) may not be supplied; this depends on your application.

* Refer to the Amendment at the front of this manual for details about these connectors.

Table 1 - Checklist of items

3.2 Fit the iQ Interface Module

You can fit the iQ Interface Module to a wall or in a panel. Use four suitable bolts and washers through the fixing-holes (Figure 2, item 1) to secure the iQ Interface Module in position.

3.3 Connect to your emergency stop equipment (if necessary)

Note: If required, you can use extend the iQ emergency stop cable(s) up to a maximum length of 10 m. Refer to Section 7.2 for the Item Numbers of extension cables.

Use the following procedure to connect each iQ system to the iQ Interface Module, if you want to use your own control equipment to stop the iQ system in an emergency:

1. Fit the connector at one end of the iQ emergency stop cable to the external emergency stop connector on the rear of the iQ Electric Module: refer to the instruction manual supplied with the iQ system.
2. Fit the connector at the other end of the iQ emergency stop cable to the emergency stop connector on the interface connector panel: refer to the Amendment at the front of this manual.

3.4 Connect the iQ Interface Module to the iQ pumping system and to another module (optional)

Note: If required, you can extend the iQ connector cable(s) up to a maximum length of 100 m. Refer to Section 7.2 for the Item Numbers of extension cables.

1. Fit the connector on one end of the iQ connector cable to one of the module connectors on the front panel of the iQ system: refer to the iQ instruction manual.
2. Fit the connector on the other end of the iQ connector cable to the system connector (Figure 1, item 3).
3. If you want to connect the iQ Interface Module to another iQ system module (for example, a Pump Display Module), fit the connector on the end of the iQ connector cable (supplied with the other iQ system module) to the module connector (Figure 1, item 2).

If you do not want to connect the iQ Interface Module to another iQ system module, fit the terminator plug to the module connector (Figure 1, item 2).

3.5 Connect the iQ Interface Module to other control equipment

Connect the iQ Interface Module to your process tool, PC (personal computer) or other control equipment through the connectors on the interface connector panels (Figure 1, items 1). Refer to:

- The information in Section 4 for the use of the iQ Interface Module input and output signals.
- The Amendment at the front of this manual, which defines the type of connectors supplied and the use of the connector pins.

4 OPERATION

4.1 Introduction

Operate the Interface Cards as described in the following sections. Where necessary, refer to the iQ pumping system instruction manual, or to the instruction manual(s) supplied with other pumping system components (for example, gate valves).

The actual connections available on your iQ Interface Module are described in the Amendment at the front of this manual.

4.2 Tool Interface Card

4.2.1 Inputs and outputs

The Tool Interface Card has eight inputs (see Table 2); use these inputs to control the operation of the iQ system. Inputs can be one of two types, as defined in Section 2.2. In Table 2, the terms 'set' and 'reset' are used as described below.

- 'Set' means that you must set the input high if it is a type 1 (a.c./d.c.) input, or you must close (link) the input if it is a type 2 (volt-free contacts) input.
- 'Reset' means that you must set the input low if it is a type 1 (a.c./d.c.) input, or you must open (unlink) the input if it is a type 2 (volt-free contacts) input.

You must allow at least 10 seconds between successive set/reset inputs.

Input	Function	Use
1	QDP on/off	Set the input to switch on the iQDP pump. Reset the input to switch off the pump.
2	QMB on/off	Set the input to switch on the iQMB pump. Reset the input to switch off the pump.
3	Both pumps on/off	Set the input to switch on both pumps. Reset the input to switch off both pumps.
4	Process on/off	Set the input to select process on. Reset the input to select process off.
5	Open/close valve	Set the input to open the valve. Reset the input to close the valve.
6	Run Til Crash on/off	Set the input to select Run Til Crash on. Reset the input to select Run Til Crash off
7	Fast/Auto shut-down	Set the input to select Auto shut-down. Reset the input to select Fast shut-down.
8	Process tool select *	Set the input for process tool type B. Reset the input for process tool type A.

* See Section 4.2.2.

Table 2 - Tool Interface Card inputs

The Tool Interface Card has eight outputs (see Table 3); use these outputs to monitor the status of the iQ system. Note that the meanings of some of these outputs depend on your tool type: use input 8 (see Table 2) to select the tool type.

Outputs can be either normally-open or normally closed. In Table 3, the terms 'set' and 'reset' are used as described in Table 4.

Output	Function	Meaning	
		Tool type A *	Tool type B *
1	iQDP On	If the output is set, the iQDP pump is on.	
2	iQMB On	If the output is set, the iQMB pump is on.	
3	Both pumps on	If the output is set, both pumps are on.	
4	Pump warning †	If the output is set, no iQ warning condition exists.	If the output is set, no iQ warning condition exists.
5	Pump alarm	If the output is set, no iQ alarm condition exists.	
6	Gas flow warning	If the output is set, no gas purge flow warning condition exists.	
7	Pump status	If the output is set, the pumps are on and no gas purge flow warning or alarm condition exists. If the output is reset, the pumps are off and/or a gas purge flow warning or alarm condition exists.	If the output is set, the cooling-water flow through the iQ system is acceptable. If the output is reset, the cooling-water flow through the iQ system is too low.
8	Exhaust pressure warning	If the output is set, no exhaust pressure warning condition exists.	

* See Section 4.2.2.

† Note that your system may be configured so that some warnings are ignored.

Table 3 - Tool Interface Card outputs

Output type	Meanings used in Table 3	
	Set	Reset
Normally-open	Closed	Open
Normally-closed	Open	Closed

Table 4 - Tool Interface Card outputs set and reset definition

4.2.2 Tool type selection

The iQ system provides the electrical supply for the iQ Interface Module. Tool type (A or B) is selected as follows:

- When the electrical supply for the iQ Interface Module is first switched on (that is, the iQ system is switched on), the tool type is determined from the state of input 8. Thereafter, the input is ignored (that is, a change in the state of input 8 will not change tool type).
- To change the tool type, you must switch off the iQ system then switch it on again, with input 8 in the correct state for the tool type.

4.2.3 Use of the buttons and LEDs

Refer to Figure 1. Some of the uses of the buttons and LEDs for the Tool Interface Card are described below. For the uses of the other LEDs and buttons, refer to the iQ system instruction manual.

Default button (4)	Use this to reset the configuration store: see Section 4.2.4.
Local Control LED (7)	This is on when the Tool Interface Card has control of the iQ system.
OK LED (8)	This green LED is on when no faults are detected in the Tool Interface Card (by its self-test facility). If the LED goes off, there is a fault: contact your supplier or Edwards for advice.

4.2.4 Setpoints store

The Tool Interface Card has a configuration store of iQ system configuration parameters (such as setpoints). Whenever you switch on the iQ system, the information in the store is sent to the iQ system and overwrites the configuration parameters in the iQ system.

To put new information in the configuration store (for example, to preset the store for your application), you must upload the information from a PC (refer to the instruction manual supplied with the iQ System Network Monitor Software).

If you press the default button (Figure 1, item 6), the Tool Interface Card configuration parameters in the store are reset to their default values.

4.2.5 Take and release control

When you use the Interface Module to control the operation of the iQ pumping system, the Tool Interface Card will try to take control. The Tool Interface Card can only take control if no other iQ module (for example, a Pump Display Module) has control. If another module has control, the Tool Interface Card will continue to try to take control.

Once the Tool Interface Card has control, no other module can operate the iQ system until the Tool Interface Card has released control; the Tool Interface Card only releases control when it is used to switch off the iQDP pump in the iQ system.

Note also that:

- If the Tool Interface Card detects an alarm condition, it will release control; this then allows another module (for example, a Pump Display Module) to control the iQ system.
- The modules connected to the iQ system communicate with the iQ system; a 'timeout' occurs if a connected module stops communicating with the iQ system for 90 seconds. If a timeout occurs on a module which has control (for example, if a Pump Display Module which has control is disconnected from the iQ system), control is automatically release from the timeout module; this allows other modules to take control and to switch off the iQ system, if required.
- Once an alarm condition is detected, you cannot use the Tool Interface Card to control the iQ system until the system has been manually restarted (with a Pump Display Module, or with the iQ System Network Monitor Software).

4.3 Auxiliary Interface Card

4.3.1 Inputs and outputs

The Auxiliary Interface Card has eight inputs, as shown in Table 5; use the inputs to control the operation of and to monitor the status of the iQ system components. The Auxiliary Interface Card has eight outputs, as shown in Table 6; use the outputs to monitor the status of the pumping system components. In Tables 5 and 6, 'set' and 'reset' are as defined in Section 4.2.1.

Refer to Figure 1. The uses of the default button (9), service button (10) and OK LED (13) are the same as for the Tool Interface Card: refer to Section 4.2.3.

Input	Function	Use
1	Valve closed	The input is set (by the valve) if the valve is closed.
2	Valve open	The input is set (by the valve) if the valve is open.
3 and 4	-	Not used.
5	Load-lock pump alarm	The input is set (by the load lock pumping system) if there is a load lock pump alarm condition.
6	Load-lock pump warning	The input is set (by the load lock pumping system) if there is a load lock pump warning condition.
7	Load-lock pump on	The input is set (by the load lock pumping system) if the load lock pump is on.
8	Load-lock pump on	The process tool must set the input to switch on the load lock pump and reset the input to switch off the load lock pump.

Table 5 - Auxiliary Interface Card inputs

Output	Function	Use
1	Open/close valve	This output is reset (by the Auxiliary Interface Card) to open the valve; the output is set to close the valve: refer to Sections 4.3.2 to 4.3.4.
2	-	Not used.
3	Load-lock pump on	This output is set to indicate that the load-lock pump is on.
4	Load-lock pump alarm	This output is reset to indicate that there is a load-lock pump alarm condition.
5	Load-lock pump warning	This output is reset to indicate that there is a load-lock pump warning condition.
6	Load-lock pump running	This output is set to indicate that the load-lock pump is on
7 and 8	-	Not used

Table 6 - Auxiliary Interface Card outputs

4.3.2 Introduction to gate valve operation

<p>WARNING</p> <p>Before you select the gate valve open or closed, ensure that it is safe to do so.</p>
--

The gate valve operation of the Auxiliary Interface Card may be configured (through the iQ Single Pumpset Monitor software) in one of two ways:

- Default configuration
- Non-default configuration

Refer to the instruction manual supplied with the Single Pumpset Monitor for details of how to select these configurations.

4.3.3 Gate valve operation: normal pumping system operation

In the default configuration, the valve will operate as follows:

- The gate valve will open after a specific delay after the iQDP pump is started; this delay is configurable.
- The gate valve will close after a specific delay after the iQDP pump is switched off; this delay is configurable.

In the default configuration, you can also use the Process Tool or the Pump Display Module to open and close the gate valve, however the valve will always open/close when the iQDP pump is started/switched off, as described above.

In the non-default configuration, use the Process Tool or the Pump Display Module to open and close the gate valve, as required.

4.3.4 Emergency shut-down/emergency stop

When the iQ system is automatically shut down as the result of an alarm, or when emergency stop is selected, the sequence of operations is as follows:

- In the default configuration, the Auxiliary Interface Card will immediately close the gate valve and switch off the load-lock pump.
- In the non-default configuration, the Auxiliary Interface Card will immediately close the gate valve but will not switch off the load-lock pump.

5 MAINTENANCE

Do the following checks when you maintain the iQ system:

- Check that the iQ Interface Module is securely fixed in place.
- Inspect all electrical connections and check that they are secure. Tighten any loose connections.
- Inspect all electrical cables and check that they are not damaged and have not overheated. Replace any cable that is damaged or has overheated.

6 STORAGE AND DISPOSAL

6.1 Storage

Store the iQ Interface Module in clean dry conditions until required. When required for use, install the iQ Interface Module as described in Section 3 of this manual.

6.2 Disposal

Dispose of the iQ Interface Module and any components safely in accordance with all local and national safety and environmental requirements.

7 SPARES AND ACCESSORIES

7.1 Introduction

Edwards products, spares and accessories are available from Edwards companies in Belgium, Brazil, Canada, France, Germany, Hong Kong, Italy, Japan, Korea, Switzerland, United Kingdom, U.S.A and a worldwide network of distributors. The majority of these centres employ Service Engineers who have undergone comprehensive Edwards training courses.

Order spare parts and accessories from your nearest Edwards company or distributor. When you order, please state for each part required:

- Model and Item Number of your equipment
- Serial number (if any)
- Item Number and description of the part.

7.2 Spares

Spare	Item Number
iQ module connector cable, 3 m	D372-07-591
iQ module connector cable, 5 m	D372-07-592
iQ module connector cable, 10 m	D372-07-595
iQ emergency stop cable, 3 m	D372-07-598
iQ emergency stop cable, 5 m	D372-07-593
iQ emergency stop cable, 10 m	D372-07-599
Terminator plug	A532-20-050