

# *Instruction Manual*

## iM Communications Modules

Description	Item Number
iM Serial Communications Module	D372-32-000
iM Serial/Parallel Communications Module	D372-35-000
iM Parallel Communications Module	D372-36-000

Chemtech Scientific provides access to this content as a courtesy.  
We do not own the content contained in this document.  
All rights and credit go directly to its rightful owners.  
[www.chemtechsci.com](http://www.chemtechsci.com)  
Call us at: 484-424-9415

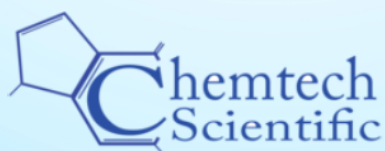

# Declaration of Conformity

We, Edwards,  
Manor Royal,  
Crawley,  
West Sussex, RH10 9LW, UK

declare under our sole responsibility, as manufacturer and person within the EU authorised to assemble the technical file, that the product(s)

iM Communications Module

Serial Communications Module	D372-32-000
Serial/Parallel Communications Module	D372-35-000
Parallel Communications Module	D372-36-000

to which this declaration relates is in conformity with the following standard(s) or other normative document(s)

EN 61326-2-3: 2006      Electrical equipment for measurement, control and laboratory Use. EMC requirements. Particular requirements. Test configuration, operational conditions and performance criteria for transducers with integrated or remote signal conditioning

and fulfils all the relevant provisions of

2004/108/EC      Electromagnetic Compatibility (EMC) Directive

*Note: This declaration covers all product serial numbers from the date this Declaration was signed onwards.*

\_\_\_\_\_  
Mr L. Marini, Technical Manager

9 December 2009

\_\_\_\_\_  
Date and Place

*This product has been manufactured under a quality system registered to ISO9001*

# Contents

Section	Page
<b>1</b>	<b>Introduction</b> ..... 1
1.1	Scope and definitions ..... 1
1.2	Description ..... 1
1.3	Connectors ..... 2
<b>2</b>	<b>Technical Data</b> ..... 5
2.1	General ..... 5
2.2	Parallel interface card ..... 5
2.3	Serial interface card ..... 5
2.4	Connectors ..... 5
<b>3</b>	<b>Installation</b> ..... 7
3.1	Unpack and inspect ..... 7
3.2	Fit the Communications Module ..... 7
3.3	Connect the Communications Module to the dry pumping system and (optionally) to another pumping system module ..... 9
3.4	Connect the Communications Module to your control equipment ..... 9
3.4.1	Parallel interface connections ..... 9
3.4.2	Serial interface connections ..... 10
3.4.3	Serial interface performance ..... 10
3.5	Connect the protective earth (ground): optional ..... 11
<b>4</b>	<b>Parallel Interface Operation</b> ..... 13
4.1	Introduction ..... 13
4.2	Inputs ..... 13
4.3	Outputs ..... 14
4.4	Setpoints and configuration parameters ..... 15
4.5	Take and release control ..... 15
<b>5</b>	<b>Serial Interface Operation</b> ..... 17
5.1	Message formats ..... 17
5.2	Reply messages ..... 17
5.3	Query messages ..... 17
5.3.1	Introduction ..... 17
5.3.2	Alarm status query message (?A) ..... 22
5.3.3	Bitfield status query message (?B) ..... 22
5.3.4	Control status query message (?C) ..... 22
5.3.5	Gas ballast status query message (?D) ..... 22
5.3.6	Format mode query message (?F) ..... 22
5.3.7	Gate valve status query message (?G) ..... 23
5.3.8	Information query message (?I) ..... 23
5.3.9	Load-lock pump status query message (?L) ..... 23
5.3.10	Nitrogen supply status query message (?N) ..... 23
5.3.11	On process status query message (?O) ..... 23
5.3.12	Pump status query message (?P) ..... 24
5.3.13	Run til crash status query message (?R) ..... 24
5.3.14	Serial number query message (?S) ..... 24
5.3.15	Pump node type query message (?T) ..... 24
5.3.16	Inlet purge status query message (?U) ..... 24
5.3.17	Value query message (?V) ..... 24

5.4	Command messages .....	25
5.4.1	Message syntax .....	25
5.4.2	Control command message (!C) .....	25
5.4.3	Gas ballast command message (!D) .....	25
5.4.4	Format mode command message (!F) .....	25
5.4.5	Gate valve command message (!G) .....	26
5.4.6	Load-lock pump command message (!L) .....	26
5.4.7	Simulation mode command message (!M) .....	26
5.4.8	Nitrogen supply command message (!N) .....	26
5.4.9	On process command message (!O) .....	26
5.4.10	Pump command message (!P) .....	26
5.4.11	Run til crash command message (!R) .....	26
5.4.12	Inlet purge command message (!U) .....	27
5.5	Simulation mode .....	27
5.5.1	Introduction .....	27
5.5.2	Simulated pumping system .....	27
<b>6</b>	<b>Maintenance .....</b>	<b>29</b>
6.1	Inspect the electrical connections .....	29
6.2	Fault finding .....	29
6.2.1	Error number reply messages .....	29
6.2.2	Determine the pumping system error number .....	29
6.2.3	Serial communications problems .....	30
<b>7</b>	<b>Storage and Disposal .....</b>	<b>31</b>
7.1	Storage .....	31
7.2	Disposal .....	31
<b>8</b>	<b>Service, Spares and Accessories .....</b>	<b>33</b>
8.1	Introduction .....	33
8.2	Service .....	33
8.3	Spares .....	33
8.4	Accessories .....	33

## Illustrations

Figure		Page
1	Components of the Communications Modules .....	3
2	Dimensions (mm) .....	6
3	Fit the Communications Module to an iH or iL dry pumping system .....	8

# Tables

Table		Page
1	Checklist of items .....	7
2	Serial interface connections .....	10
3	Example IBM PC-compatible serial connections .....	10
4	Parallel interface inputs .....	13
5	Parallel interface outputs .....	14
6	Alarm type .....	18
7	Query messages .....	19
8	Parameters .....	20
9	Priority level .....	21
10	Bitfield status .....	21
11	Status level .....	22
12	Typical control object values .....	22
13	Command messages .....	25
14	Simulated pumping system data .....	27
15	Serial interface error numbers .....	29
16	Serial communications fault finding .....	30

# 1 Introduction

## 1.1 Scope and definitions

This instruction manual provides installation, operation and maintenance instructions for the Edwards iM Communications Modules, abbreviated to Communications Module in the remainder of this manual. You must use the Communications Module as described in this manual.

Read this manual before you install and use the Communications Module. Important safety information is highlighted as CAUTION instructions; you must obey these instructions. The use of CAUTIONS is defined below.

---

### CAUTION

Cautions are given where failure to observe the instruction could result in damage to the equipment, associated equipment and process.

---

The following labels appear on the Communications Module:



Caution - Refer to accompanying documentation.



Protective earth (ground) terminal.

The units used throughout this manual conform to the SI international system of units of measurement.

## 1.2 Description

The Communications Module allows you to use your own control equipment to control the operation of and to monitor the status of an iH, iL or iQ dry pumping system.

Three types of Communications Module are available (see [Figure 1](#)):

- The Serial Communications Module contains a serial interface card, which allows you to control the operation of and to monitor the status of the dry pumping system through a serial interface. The serial interface card uses RS232 serial communications to communicate with your control equipment. For example, you can connect the Communications Module to the serial port of a PC (Personal Computer) on which you have installed a suitable SCADA (Supervisory Control And Data Acquisition program).
- The Parallel Communications Module contains a parallel interface card, which allows you to control the operation of and to monitor the status of the dry pumping system through a parallel interface (for example, connected to your process tool).
- The Serial/Parallel Communications Module contains both serial and parallel interface cards, which can be used as described above.

Note that you can only connect to, monitor and control an iH, iL or iQ dry pumping system through either a Communications Module, or through an Interface Module; you cannot have both a Communications Module and an Interface Module connected to the dry pumping system.

**Note:** *All information sent to or received from the Communications Module (whether serial or parallel data) is software derived; there is no direct electrical wiring to the sensors, pumps or valves in the dry pumping system.*

## 1.3 Connectors

Refer to [Figure 1](#). The Communications Module is connected to the dry pumping system through the system connector (3).

If required, the module connector (4) is used to connect the Communications Module to other pumping system modules (for example, a Pump Display Module). If no other pumping system modules are to be connected, a network terminator plug must be connected to the module connector (4).

If the Communications Module has a parallel interface card, the Communications Module is connected to the parallel interface of your control equipment through the parallel connector (7).

If the Communications Module has a serial interface card, the Communications Module is connected to the serial interface of your control equipment through the serial connector (1).

Figure 1 - Components of the Communications Modules

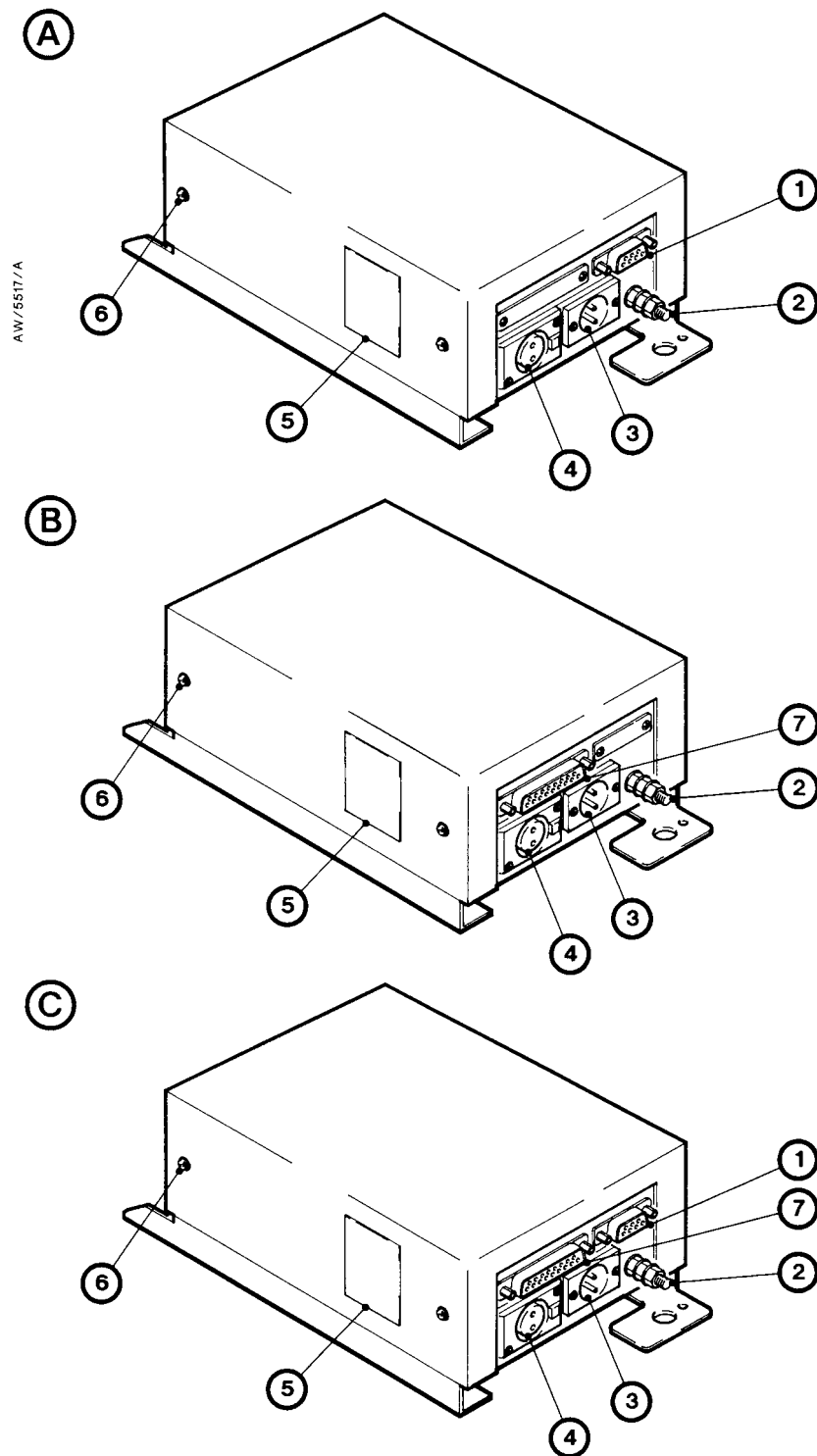

- A. Serial Communications Module
- B. Parallel Communications Module
- C. Serial/Parallel Communications Module

- 1. Serial connector
- 2. Protective earth (ground) stud
- 3. System connector
- 4. Module connector
- 5. Identification plate
- 6. Cover fixing screw
- 7. Parallel connector



## 2 Technical Data

### 2.1 General

Dimensions	See Figure 2
Maximum mass	1 kg
Operating temperature range	0 to 55 °C
Storage temperature range	-20 to 65 °C
Operating humidity range	25 to 95% RH at 40 °C
Maximum storage humidity	90% RH at 65 °C for 12 hours
Maximum operating altitude	4500 m
Maximum storage altitude	8000 m

### 2.2 Parallel interface card

Inputs:	Number	3
	Type	Volt-free dry contacts
	Maximum voltage	24V
Outputs:	Number	5
	Type	Normally open relays
	Maximum rating	1 A, 24 V

### 2.3 Serial interface card

**Note:** The signal and earth (ground) connections are isolated from the chassis of the Communications Module, with a 500 V maximum isolation rating.

Inputs:	Number	1
	Type	RS-232 'RX data'
	Rating	Compliant with EIA RS-232
Outputs:	Number	1
	Type	RS-232 'TX data'
	Rating	Compliant with EIA RS-232
Communications		
	Protocol	EIA RS-232
	Baud rate	9600 baud
	Data bits	8
	Stop bits	1
	Parity setting	No parity

### 2.4 Connectors

System connector	4-way XLR plug
Module connector	4-way XLR socket
Parallel connector	25-way D-type plug
Serial connector	9-way D-type socket

Figure 2 - Dimensions (mm)

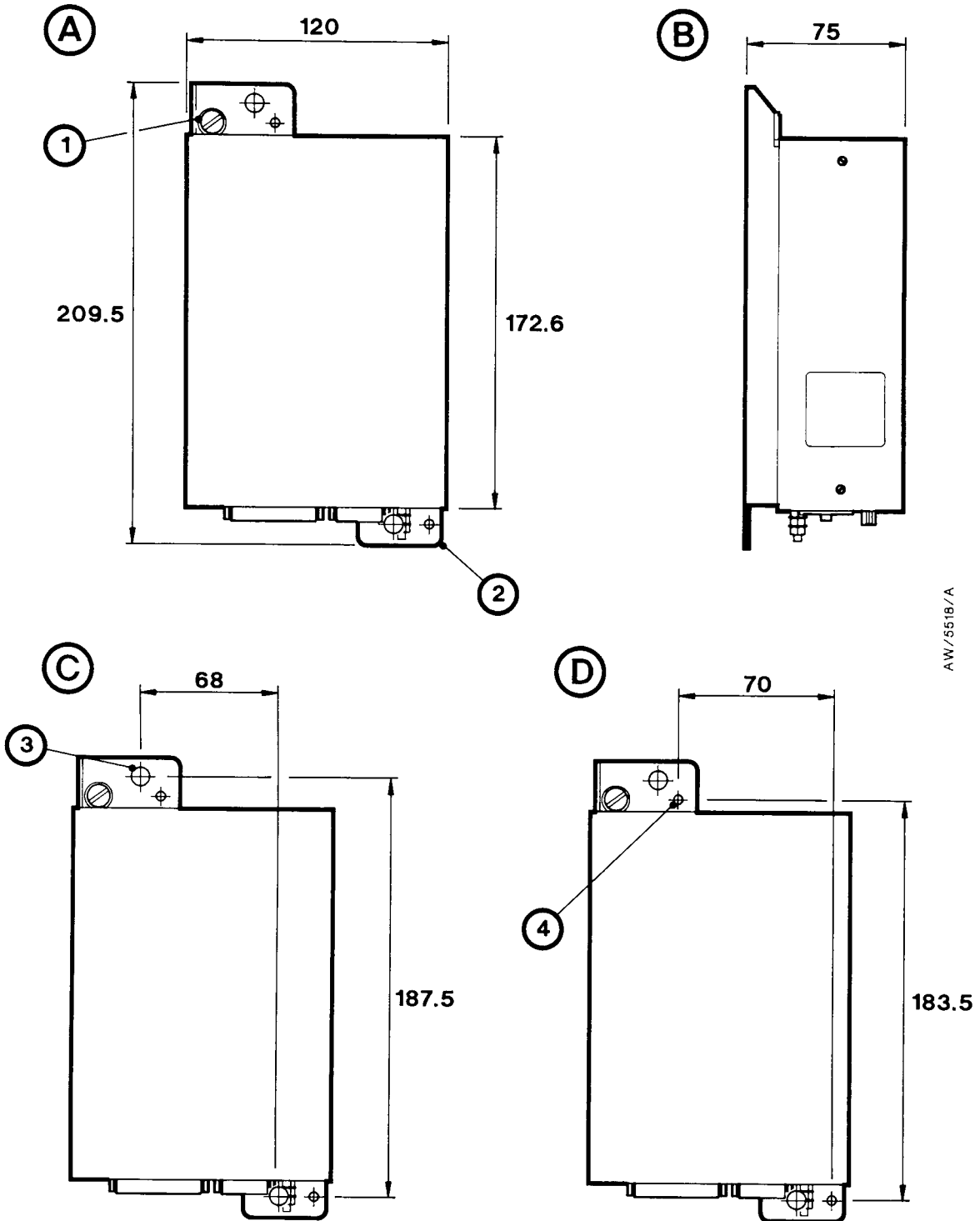

AW/5518/A

## 3 Installation

### 3.1 Unpack and inspect

Remove all packing materials and check the Communications Module. If the Communications Module is damaged, notify your supplier and the carrier in writing within three days; state the Item Number of the Communications Module together with your order number and your supplier's invoice number. Do not use the Communications Module if it is damaged.

Check that you have received the items listed in [Table 1](#). If any item is missing, notify your supplier in writing within three days. If you will not use the Communications Module immediately, replace any packing materials and store the Communications Module in suitable conditions, as described in [Section 6](#).

Table 1 - Checklist of items

Qty	Description	Check (✓)
1	Communications Module	<input type="checkbox"/>
1	Pumping system connector cable	<input type="checkbox"/>

### 3.2 Fit the Communications Module

You can fit the Communications Module directly to an iH or iL dry pumping system, or you can mount the Communications Module on a wall or frame:

To fit the Communications Module directly to an iH or iL dry pumping system:

1. Refer to [Figure 3](#). Fit the pumping system mounting tab (3) in the fixing slot (4) on the rear panel of the dry pumping system.
2. Position the (captive) pumping system mounting screw (1) into the fixing hole (5) on the rear panel of the dry pumping system, then tighten the screw to secure the Communications Module in position.

Refer to [Figure 2](#), detail C. To fit the communications module to a frame (uni-strut), use two suitable bolts and washers through the frame fixing holes (3) to secure the Communications Module in position.

Refer to [Figure 2](#), detail D. To fit the communications module to a wall, use two suitable bolts and washers through the wall fixing holes (4) to secure the Communications Module in position.

Figure 3 - Fit the Communications Module to an iH or iL dry pumping system

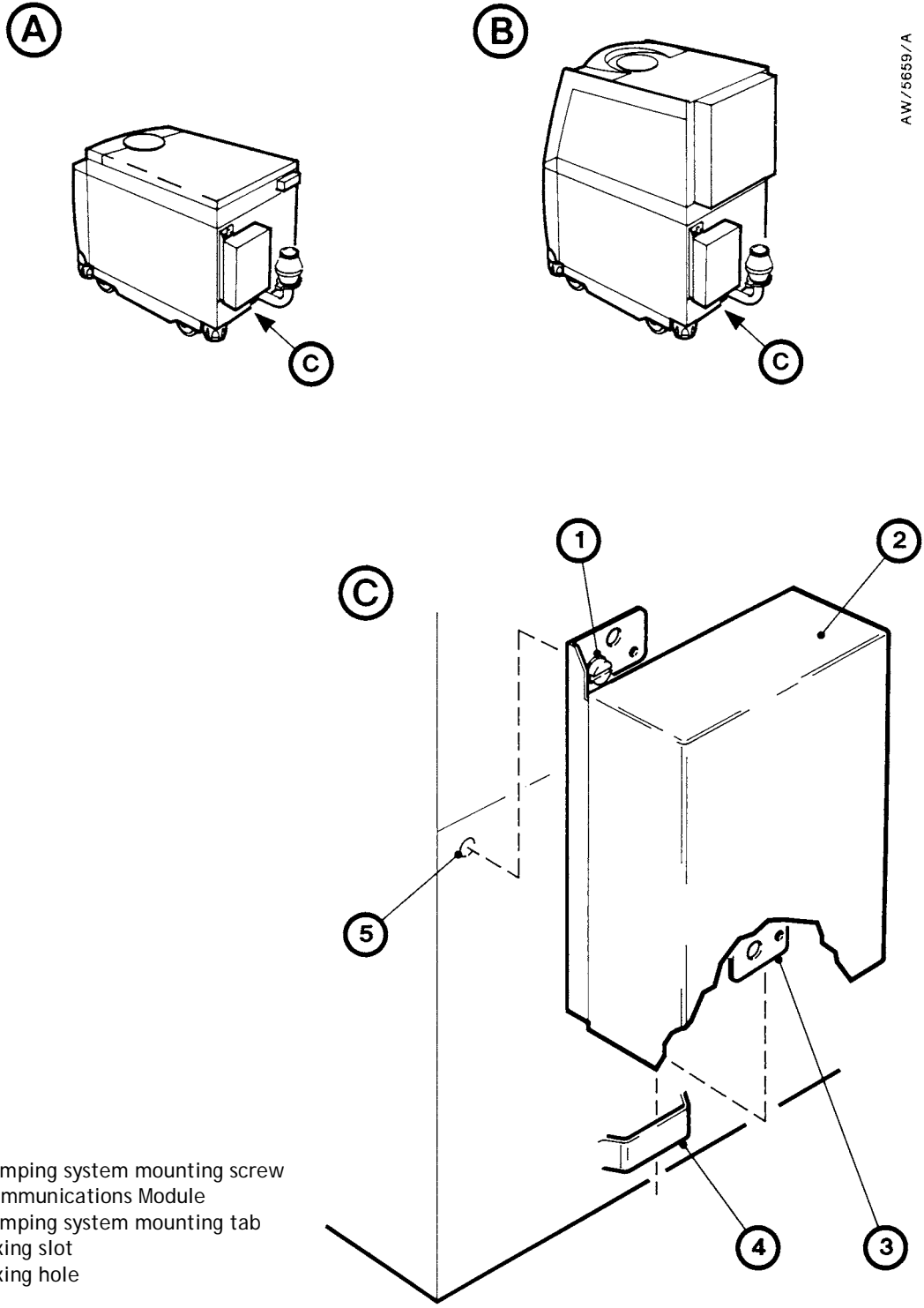

### 3.3 Connect the Communications Module to the dry pumping system and (optionally) to another pumping system module

Use the following procedure to connect the Communications Module to the dry pumping system, and (optionally) to another pumping system module; where necessary, refer to the instruction manual supplied with your dry pumping system.

1. On an iH or iL dry pumping system, remove the 4-way XLR terminator plug or the module connector cable from the Interface Module connector on the Electrics and Pump Control Module.

On an iQ dry pumping system, remove the 4-way XLR terminator plug or the module connector cable from the module connector on the front panel of the dry pumping system.

2. Refer to [Figure 1](#). Fit the terminator plug (supplied with the dry pumping system) or the module connector cable to the module connector (4) on the Communications Module.
3. Connect one end of the module connector cable supplied with the Communications Module to the Interface Module connector on the iH or iL dry pumping system, or to the module connector on the iQ dry pumping system.
4. Connect the other end of the module connector cable to the system connector (3) on the Communications Module.

### 3.4 Connect the Communications Module to your control equipment

---

#### CAUTION

The dry pumping system may not operate correctly if you connect both an Interface Module and a Communications Module with a parallel interface card to the dry pumping system.

---

*Note:* The Communications Module makes no provision for emergency stop or other safety interlocks. You must make other provisions for such requirements.

Use the following procedure to connect the Communications Module to your control equipment. Note that you must connect to your control equipment either through a Communications Module or through an Interface Module; you must not connect to both of these.

#### 3.4.1 Parallel interface connections

*Note:* Refer to [Section 4](#) to determine the signals used in the parallel cable.

1. Make a suitable parallel cable (terminated by a 25-way D-type socket).
2. Connect one end of the parallel cable to your control equipment.
3. Refer to [Figure 1](#). Fit the socket at the other end of the cable to the parallel connector (7) on the Communications Module.

### 3.4.2 Serial interface connections

1. Ensure that your control equipment is correctly configured (for example, install the necessary software) to interpret your commands, to send and receive messages to and from the Communications Module, and to display information received from the Communications Module.
2. Ensure that the serial settings of your control equipment are configured correctly for the Communications Module: refer to the information given in [Section 2](#).
3. Make a three-wire RS232 cable to connect your control equipment to the Communications Module: [Table 2](#) shows the serial interface connection signals and [Table 3](#) shows example IBM PC-compatible connections. If the cable between your control equipment and the Communications Module is more than 10 m long, you must incorporate line-drivers in the cable. When you make the cable:
  - Fit a 9-way female D-type plug on one end of the cable.
  - Fit a connector suitable for the serial connector on your control equipment to the other end of the cable. Typically, this will be a 9-way female D-type connector, to fit the COM port of your PC.
4. Refer to [Figure 1](#). Fit the 9-way D-type plug on one end of the RS232 cable to the serial connector (1) on the Communications Module; fit the connector on the other end of your RS232 cable to the appropriate connector on your control equipment.

Table 2 - Serial interface connections

Signal	Serial Connector (9-way D-type plug)	Direction
RXD	Pin 2	Output
TXD	Pin 3	Input
GND	Pin 5	-

Table 3 - Example IBM PC-compatible serial connections

Signal	Serial Connector (9-way D-type plug)	IBM PC compatible connectors	
		9-way D-type male	25-way D-type male
RXD	Pin 2	Pin 2	Pin 3
TXD	Pin 3	Pin 3	Pin 2
GND	Pin 5	Pin 5	Pin 7

### 3.4.3 Serial interface performance

The SCM (Serial Communications Module) has to process both the LON network messages (which arrive when sent by the pumping system) and the serial messages. It is not possible to provide definitive performance figures for the serial interface, as it will vary with time according to the pumping system configuration and operation. However, the following information is provided to assist in programming your control equipment for optimum operation with the serial interface.

- The pumping system sends data from each object at relatively slow frequencies, usually regularly at 3, 7, 15 or 45 second intervals. Messages are also sent by the pumping system when there is a sudden change in status.
- At 9600 baud, each character in a command/query message or the corresponding reply message will take approximately 1 ms. The response for a query message takes, typically, 30 to 50 ms.
- Command messages can take several seconds to be actioned, as a serial response is sent: that is, the command message is sent to the pumping system through the LON network, then the pumping system must action the message.

- We recommend that you do not send a new command/query message until the reply message for the previous command/query message has been received. A small delay of, say, 100 ms will allow the SCM to process any LON messages, and to carry out internal 'housekeeping'.
- If the serial link is overloaded, the worst effect will be that the SCM will miss a data update from the pumping system, however, the new data will then be provided by the pumping system at the next regular update. There will be no direct effect on the operation of the pumping system.

### 3.5 Connect the protective earth (ground): optional

Although the Communications Module presents no electrical hazards, we recommend that you connect a suitable protective earth (ground) cable between the protective earth (ground) stud on the Communications Module (Figure 1, item 2) and the protective earth (ground) stud on the dry pumping system: refer to the instruction manual supplied with your dry pumping system.

If you have mounted the Communications Module on a wall or frame, make a suitable earth (ground) cable in accordance with your local and national electrical regulations, and connect the cable between the protective earth (ground) stud on the Communications Module (Figure 1, item 2) and your factory earth (ground).

## 4 Parallel Interface Operation

### 4.1 Introduction

Use the parallel interface to monitor and control the dry pumping system as described in the following sections. Where necessary, refer to the instruction manual supplied with your dry pumping system, and to the instruction manual(s) supplied with other pumping system components.

### 4.2 Inputs

*Note:* You must allow at least 10 seconds between successive set/reset inputs.

The parallel interface has three inputs; use these to control the operation of the dry pumping system, as shown in Table 4. In Table 4, the terms 'set' and 'reset' are used as follows:

- 'set' means that you must close (link) the appropriate two pins of the input.
- 'reset' means that you must open (unlink) the appropriate two pins of the input.

Table 4 - Parallel interface inputs

Input	Pins	Function	Use
1	1 and 14	Start/stop the system	<p>If the 'both pumps line' configuration <sup>†</sup> is on:</p> <ul style="list-style-type: none"> <li>• Set the input to start the dry pump and the mechanical booster pump (if fitted).</li> <li>• Reset the input to stop the dry pump and the mechanical booster pump (if fitted).</li> </ul> <p>If the 'both pumps line' configuration <sup>†</sup> is off:</p> <ul style="list-style-type: none"> <li>• Set the input to start the dry pump only.</li> <li>• Reset the input to stop the dry pump only.</li> </ul>
2	2 and 15	Process On/Off	<ul style="list-style-type: none"> <li>• Set the input to indicate 'process off'.</li> <li>• Reset the input to indicate 'process on'.</li> </ul>
3	6 and 19	Start/stop the mechanical booster pump	<p>If the 'both pumps line' configuration <sup>†</sup> is on, this input is ignored</p> <p>If the 'both pumps line' configuration <sup>†</sup> is off:</p> <ul style="list-style-type: none"> <li>• Set the input to start the booster pump. <sup>*</sup></li> <li>• Reset the input to stop the booster pump.</li> </ul>

<sup>\*</sup> The mechanical booster pump will not start unless the dry pump is on. The input is ignored if no mechanical booster pump is fitted to the dry pumping system.

<sup>†</sup> This configuration can be downloaded from the SPM (Single Pumpset Monitor); refer to the instruction manual supplied with the SPM.



### 4.3 Outputs

The parallel interface has five outputs; use these to monitor the status of the dry pumping system, as shown in Table 5. In Table 5, the terms 'set' and 'reset' are used as follows:

- 'set' means that the output relay is closed (short circuit).
- 'reset' means that the output relay is open (open circuit).

Table 5 - Parallel interface outputs

Output	Pins	Function	Use
1	8 and 20	Pumps running	If the output is set, the pump(s) are on.
2	9 and 21	Pumps not in warning	A warning from any of the parameters listed in the configuration 'alerts to tool' on object 135 will cause the Pumps Not In Warning Line to be reset. The default list is: Dry pump current (3) Dry pump power (4) Exhaust Pressure (39) Dry Pump Motor Temperature (55) Dry Pump Body Temperature (57) Gate Valve Not Closed (152) Gate Valve Not Opened (153) It will be set if no warning condition exists for any of the parameters listed above. This list can be changed by downloading a configuration from the SPM (Single Pumpset Monitor): refer to the instructions supplied with the SPM.
3	10 and 22	Pumps not in alarm	An Alarm from any of the parameters listed in the configuration 'alerts to tool' on object 136 will cause the Pumps Not In Alarm Line to be reset. The default list is: EMS Alarm from node object (1) Dry pump current (3) Dry pump power (4) Dry Pump Thermistor (5) Dry Pump no current (11) Exhaust Pressure (39) Dry Pump Motor Temperature (55) Dry Pump Body Temperature (57) It will be set if no Alarm condition exists for any of the parameters listed above. This list can be changed by downloading a configuration from the SPM (Single Pumpset Monitor): refer to the instructions supplied with the SPM.
4	11 and 23	Gas flow not in warning	If the output is set, no gas flow warning exists.
5	12 and 24	Final valve	If the output is set, the dry pumping system is operating normally and no gas purge flow warning condition exists.

## 4.4 Setpoints and configuration parameters

The parallel interface card has a store of sensor setpoints and configuration parameters. This store is preset for your application. Whenever you switch on the dry pumping system, the information in this store is sent to the dry pumping system and overwrites the setpoints already in the system.

To put new information in the store, you must download the new information from a PC, through the Single Pumpset Monitor or Central Monitoring System software (refer to the dry pumping system instruction manual).

Note that if you connect the Communications Module to an iQ dry pumping system, any iH/iL setpoint information stored will not be downloaded to the iQ dry pumping system. Similarly, if you store iQ setpoint information in the Communications Module and the Communications Module is connected to an iH/iL dry pumping system, the iQ setpoint information stored will not be downloaded to the iH/iL dry pumping system.

## 4.5 Take and release control

When you use the parallel interface card to control the operation of the dry pumping system, the parallel interface card will try to take control of the dry pumping system. The parallel interface card can only take control if no other pumping system module (for example, a Pump Display Module) already has control.

Once the parallel interface card has control, no other module can operate the dry pumping system until the parallel interface card has released control; the parallel interface card only releases control when it is used to switch off the dry pumping system.

Note also that:

- If the parallel interface card detects an alarm condition, it will release control; this then allows another module (for example, a Pump Display Module) to switch off the dry pumping system.
- The modules connected to a dry pumping system communicate with the system; a time-out occurs if a connected module stops communicating with the dry pumping system for 90 seconds. If a time-out occurs on a module which has control (for example, if a Pump Display Module which has control is disconnected from the dry pumping system), control is automatically released from the module which has timed out. This allows other modules to take control and switch off the dry pumping system, if required.
- If the parallel interface card has control of the dry pumping system and the mechanical booster pump is automatically shut down, you can use the Pump Display Module to restart the mechanical booster pump without the need to release control from the parallel interface card.

## 5 Serial Interface Operation

### 5.1 Message formats

**Note:** *The serial interface protocol is case-sensitive. You must therefore use upper case text characters in serial interface messages.*

Each message sent by your control equipment to the serial interface card must be a string of ASCII characters terminated by a <CR> (carriage return character, ASCII code 13). You can include spaces in the messages to make them more readable; the spaces are ignored by the serial interface card.

You can send two types of message to the serial interface card and the first character of the message defines the message type, as follows:

- If the first character is “?” (question mark), the message is a query. A query message causes a value (or values) to be returned from the serial interface card. Query messages are described in [Section 5.3](#).
- If the first character is a “!” (exclamation mark), the message is a command. Commands effect some action on the dry pumping system and then return a value to identify whether the command was valid or not. Command messages are described in [Section 5.4](#).

Messages sent to the serial interface card are queued in a buffer and then read and actioned by the serial interface card one at a time. You can send the “/” character (ASCII code 47) to clear (empty) the buffer at any time; any unactioned messages are ignored by the serial interface card. Send the “/” character to reset the serial interface card before you start to send query and command messages.

### 5.2 Reply messages

When the serial interface card receives a query or command message, it always sends a reply message to your control equipment. A reply message is a string of ASCII characters terminated by the two control characters <CR><LF> (carriage return and line feed, ASCII codes 13 and 10).

The content of a reply message for a query message depends on the query message sent: refer to [Section 5.3.1](#). If a query message is invalid (that is, is in the wrong format), the reply message will be in the form “ERR<\_>n<CR><LF>”, where “<\_>” specifies a space and “n” specifies an error number: refer to [Section 6.2.1](#) for the meanings of error numbers.

The reply message for a command message is always in the form “ERR<\_>n<CR><LF>”. If the command message was valid, “n” (the error number) will be 0. If the message was invalid, “n” specifies an error number: refer to [Section 6.2.1](#) for the meanings of error numbers.

### 5.3 Query messages

#### 5.3.1 Introduction

The query messages that you can send to the serial interface card are shown in [Table 7](#); these are listed in alphabetical message syntax order. The query messages are fully described in [Section 5.3.2](#) to [5.3.13](#). A reply to a query message can be in one of two formats: short reply or long reply. Use the format mode command message to select long or short reply format: refer to [Section 5.4.3](#).

In Table 7, items enclosed in curled brackets, for example {parameter}, are items which you must specify or are variable items. These items (in alphabetical order) are as follows:

{alarm type}	This specifies the type of an alarm: refer to Table 6.
{bitfield status}	This is a number in the range 0 to 65535. When interpreted as a binary number, the bits set specify the error status of a parameter: refer to Table 10.
{booster pump}	This is a digit that specifies the mechanical booster pump in the system: 1 = no booster pump fitted; 2 = iQMB250/500; 3 = iQMB1200; 4 = QMBDD; 5 = HCMB600; 6 = HCMB1000.
{control object}	This can take any value between 0 and 255 and specifies the part of the system that has control of the dry pumping system. Refer to Table 12 for typical values.
{dry pump}	This is a digit that specifies the dry pump in the system: 1 = invalid DIP switch setting; 2 = iQDP40; 3 = iQDP80; 4 = iH80 and 5 = iL70.
{node type}	This is a number that represents the pump node type (extracted from the node broadcast): 1 = iQ, 22 = iH and 41 = iL.
{number}	The number of parameters that have a priority level > 0: see Table 9.
{on/off}	This specifies the status of a parameter and can be 0 or 1: refer to Section 5.3.2 to 5.3.13.
{on process status}	This can be 0 or 1 and specifies whether the On process flag is set (1) or not set (0).
{parameter}	This specifies a selected parameter: refer to Table 8.
{priority level}	This specifies the priority level of a parameter: refer to Table 9.
{run til crash status}	This can be 0 or 1 and specifies whether run til crash is selected (1) or not selected (0).
{serial number}	This is a 16 character string that specifies the serial number of the dry pumping system.
{status level}	This specifies the status level of a parameter: refer to Table 11.
{system type}	This is a number that indicates the type of the dry pumping system: 0 indicates iQ, 1 indicates iH and 2 indicates iL.
{u}	This field is currently unused by the dry pumping system, but is included for possible future use.
{value}	This specifies the current value of a parameter. Refer to Table 8 for the parameters and the units used for each parameter.

Table 6 - Alarm type

Value	Meaning
0	No alarm
1	Digital alarm
9	Low warning
10	Low alarm
11	High warning
12	High alarm
13	Device error *
15	Device not present

\* Refer to the {bitfield status} (see Table 10) to determine the cause of the alarm.

Table 7 - Query messages

Query Message Name	Message Syntax	Short Reply	Long Reply
Alarm status	?A{parameter}<CR>	{priority level} <CR><LF>	{priority level}, {alarm type}, {bitfield status} <CR><LF>
Bitfield status	?B{parameter}<CR>	{bitfield status} <CR><LF>	{priority level}, {alarm type}, {bitfield status} <CR><LF>
Control status	?C<CR>	{on/off}<CR><LF>	{on/off}<CR><LF>
Gas ballast status	?D<CR>	{on/off}<CR><LF>	{on/off}<CR><LF>
Format mode	?F<CR>	{on/off}<CR><LF>	{on/off}<CR><LF>
Gate valve status <sup>†</sup>	?G<CR>	{on/off}<CR><LF>	{on/off}, {priority level}, {alarm type}<CR><LF>
Information <sup>*</sup>	?I<CR>	{number}<CR><LF>	{number} [;{parameter}, {priority level}, {alarm type}, {bitfield status}]<CR><LF>
Load-lock pump status <sup>†</sup>	?L<CR>	{on/off}<CR><LF>	{on/off}, {priority level}, {alarm type}<CR><LF>
Nitrogen supply status	?N<CR>	{on/off}<CR><LF>	{on/off}<CR><LF>
On process status	?O<CR>	{on/off}<CR><LF>	{on/off}<CR><LF>
Pump status	?P<CR>	{status level}<CR><LF>	{status level}, {priority level}, {alarm type}, {bitfield status}, {run til crash status}, {on process status}, {control object}<CR><LF>
Run til crash status	?R<CR>	{on/off}<CR><LF>	{on/off}<CR><LF>
Serial number	?S<CR>	{serial number}<CR><LF>	{serial number}<CR><LF>
Pump node type	?T<CR>	{node type}<CR><LF>	{node type}, {system type}, {dry pump}, {booster pump}, {u}, {u}, {u}, {u}<CR><LF>
Inlet purge status	?U<CR>	{on/off}<CR><LF>	{on/off}<CR><LF>
Value	?V{parameter}<CR>	{value}<CR><LF>	{value}, {priority level}, {alarm type}, {bitfield status} <CR><LF>

<sup>\*</sup> In the long reply, the square brackets specify that the enclosed items may not appear in the reply message, or may not appear a number of times. Refer to [Section 5.3.7](#).

<sup>†</sup> The replies to these query messages will have no meaning if the device (gate valve or load-lock pump) is not controlled through an interface module.

Table 8 - Parameters

{parameter}	Description	Measurement Unit
1 *	Pump control	-
2	Electrical supply voltage	0.1 V
3	Dry pump phase current	0.1 A
4	Dry pump power	0.1 kW
5	Voltage reading from dry pump thermistor	0.1 mV
6	Imbalance in dry pump phase current	0.005 %
7	Mechanical booster pump phase current	0.1 A
8	Mechanical booster pump power	0.1 kW
9	Voltage reading from mechanical booster pump thermistor	0.1 mV
10	Imbalance in mechanical booster pump phase current	0.005 %
11*	Dry pump status	-
12	Mechanical booster pump status	†
13	Gas module supply	†
14	Total running time	hours
16	Hours on process	hours
18	Process cycles	-
20	Pumping system cycles	-
21	Time to stop	seconds
31 *	Gas module control	-
32	Final stage purge nitrogen flow	ml.s <sup>-1</sup>
35	Auxiliary nitrogen purge flows †/Total nitrogen purge flow **	ml.s <sup>-1</sup>
39	Exhaust pressure	0.1 kPa
40	Shaft-seals purge pressure	0.1 kPa
45	Nitrogen supply status	†
46	Interstage purge status	†
47	Inlet purge status	†
48	Time for gas sensors to zero	seconds
51 *	Sensor module control	-
52	Analogue water flow	1 ml.s <sup>-1</sup>
53	Active gauge pressure	Pa or V ††
54	Mechanical booster pump motor temperature	0.1 °K
55	Dry pump motor temperature	0.1 °K
56	Exhaust temperature	0.1 °K
57	Dry pump body temperature	0.1 °K
58	Dry pump oil status	‡‡
59	Mechanical booster pump oil status	‡‡
60	Water flow status	‡‡
111 *	NIM (Network Interface Module)	-
121 *	Parallel (tool) interface module	-
131	Parallel (tool) interface input status	see Table 10

Table 8 - Parameters

{parameter}	Description	Measurement Unit
140	Parallel (tool) interface output status	see Table 10
151*	Auxiliary interface	-
160	Auxiliary interface input status	see Table 10
169	Auxiliary interface output status	see Table 10
172	Inverter current	0.1 A
173	Inverter power	0.1 kW
174	Inverter speed	0.1 Hz
175	Inverter torque	0.005 %
176	Inverter status	-
245	GRC status	-

\* These parameters can only be specified in ?I query messages

† Information on these parameters is in the form {status level}; see Table 11

‡ iQ dry pumping systems.

\*\* iH dry pumping systems

†† Either a pressure measurement or a voltage will be returned, depending on the type of gauge fitted

‡‡ 0 (oil level or water flow low) or 1 (oil level or water flow acceptable)

Table 9 - Priority level

Value	Meaning
0	Indication only; no warning or alarm
1	Warning condition exists
2	Alarm condition exists: shut down the pump unless Run til crash is set
3	Alarm condition exists: shut down the pump

Table 10 - Bitfield status

Value	Meaning
0	Module missing
1	Sensor present at switch-on, but now disconnected
2	Wrong gas module fitted
3	Voltage above valid maximum voltage
4	Voltage below valid minimum voltage
5	ADC (analogue to digital convertor) not operating
6	Electrical supply has been interrupted
7	Watchdog reset has occurred
8	Sensor missing at switch-on
9	Module switching on
10	No current consumption at pump switch-on
11	Wrong phase input to pump
12	EMS (emergency stop) has been activated
13	Flow sensor zero out of range
14	Cannot zero sensors
15	Configuration set read error

Table 11 - Status level

Value	Meaning
0	Switched off
1	Off, switching on
2	On, switching off (shut-down after fault)
3	On, switching off (normal shut-down)
4	On

Table 12 - Typical control object values

Value	Meaning
0	No module has control
91	Single Pumpset Monitor has control
101	Pump Display Module has control
102	Remote Display has control
121	Parallel (tool) interface has control
181	Serial interface has control

### 5.3.2 Alarm status query message (?A)

Send this query message to determine the alarm status of the selected parameter.

### 5.3.3 Bitfield status query message (?B)

Send this query message to determine the bitfield status of the specified parameter. The {bitfield status} part of the reply message specifies the status: refer to [Table 10](#).

### 5.3.4 Control status query message (?C)

Send this query message to determine if the serial interface card has control of the dry pumping system. The {on/off} part of the reply message is set as follows:

- {on/off} = 0 means that the serial interface card does not have control of the system.
- {on/off} = 1 means that the serial interface card has control of the system.

### 5.3.5 Gas ballast status query message (?D)

Send this message to determine the gas ballast status. The {on/off} part of the reply message is set as follows:

- {on/off} = 0 means that gas ballast is off.
- {on/off} = 1 means that gas ballast is on.

### 5.3.6 Format mode query message (?F)

Send this query message to determine if short or long replies are selected. The {on/off} part of the reply message is set as follows:

- {on/off} = 0 means that short replies are selected.
- {on/off} = 1 means that long replies are selected.



### 5.3.7 Gate valve status query message (?G)

Send this query message to determine the status of the gate valve (if fitted). The {on/off} part of the reply message is set as follows:

- {on/off} = 0 means that the gate valve is closed.
- {on/off} = 1 means that the gate valve is open.

If you have selected long replies, the long reply message will also include the {alarm type}, set as follows:

- {alarm type} = 0 means that there is no alarm.
- {alarm type} = 9 means that the gate valve failed to open after a command message to open the valve.
- {alarm type} = 11 means that the gate valve failed to close after a command message to close the valve.

### 5.3.8 Information query message (?I)

Send this query message to determine which parameters (if any) have a priority level greater than 0. The {number} part of the reply message specifies the number of parameters which have a priority level greater than 0.

If you have selected long replies and the {number} part of the long reply message is not 0, the long reply will also contain information about all the parameters which have a priority level =1, followed by information about all the parameters which have a priority level >1.

The information for each parameter is in the form "{parameter}, {priority level}, {alarm type}, {bitfield status}". The information for each parameter is separated from the information for the previous parameter (or from the {number} part of the reply) by a ";" (semicolon) character.

### 5.3.9 Load-lock pump status query message (?L)

Send this query message to determine the status of the load-lock pump. The {on/off} part of the reply message is set as follows:

- {on/off} = 0 means that the load-lock pump is off.
- {on/off} = 1 means that the load-lock pump is on.

### 5.3.10 Nitrogen supply status query message (?N)

Send this query message to determine the status of the nitrogen supply. The {on/off} part of the reply message is set as follows:

- {on/off} = 0 means that the nitrogen supply is off.
- {on/off} = 1 means that the nitrogen supply is on.

### 5.3.11 On process status query message (?O)

Send this query message to determine whether the On process flag is set or not. The {on/off} part of the reply message is set as follows:

- {on/off} = 0 means that the On process flag is not set.
- {on/off} = 1 means that the On process flag is set.

### 5.3.12 Pump status query message (?P)

*Note:* Use the “?V12” query message to determine the status of the mechanical booster pump (if fitted).

Send this query message to determine the status of the dry pump in the dry pumping system. The {status level} part of the reply message specifies the pump status: refer to [Table 11](#).

Note that if {alarm type} in the reply message is set to 0 (no alarm), {priority level} will also be set to 0. {priority level} will only be set to the actual priority level when {alarm type} > 0.

### 5.3.13 Run til crash status query message (?R)

Send this query message to determine whether Run til crash is selected or not. The {on/off} part of the reply message is set as follows:

- {on/off} = 0 means that Run til crash is not selected.
- {on/off} = 1 means that Run til crash is selected.

### 5.3.14 Serial number query message (?S)

Send this query message to determine the serial number of the dry pumping system. The serial number is specified in the reply message.

### 5.3.15 Pump node type query message (?T)

Send this query message to determine the pump node type and/or the pumping system type, and/or the type(s) of pump(s) in the pumping system. The fields of the reply message identify the appropriate data: refer to [Table 7](#).

### 5.3.16 Inlet purge status query message (?U)

Send this query message to determine the inlet purge status. The {on/off} part of the reply message is set as follows:

- {on/off} = 0 means that inlet purge is off.
- {on/off} = 1 means that inlet purge is on.

### 5.3.17 Value query message (?V)

Send this query message to determine the current value of the selected parameter. The {value} part of the reply message specifies the current value of the parameter. Refer to [Table 8](#) for the applicable measurement unit for the parameter.

Note that if you send this query message for parameters 176 (inverter status) or 245 (GRC status), the {value} part of the reply message comprises eight hexadecimal digits; the meaning of these digits depends on your inverter or GRC equipment.

## 5.4 Command messages

### 5.4.1 Message syntax

The command messages are shown in Table 13; these are listed in alphabetical message syntax order. The messages are fully described in Section 5.4.2 to 5.4.9. In Table 13, items in brackets ({0:1} and {0:2}) are variable items which you must specify, as follows:

- {0:1} is a digit and can be 0 or 1.
- {0:2} is a digit and can be 0, 1 or 2.

Table 13 - Command messages

Command Message Name	Message Syntax
Control	!C{0:1}<CR>
Gas ballast	!D{0:1}<CR>
Format mode	!F{0:1}<CR>
Gate valve	!G{0:1}<CR>
Load-lock pump	!L{0:1}<CR>
Simulation mode	!M{0:1}<CR>
Nitrogen supply	!N{0:1}<CR>
On process	!O{0:1}<CR>
Pump	!P{0:2}<CR>
Run til crash	!R{0:1}<CR>
Inlet purge	!U{0:1}<CR>

### 5.4.2 Control command message (!C)

Send this command message to take or release control of the dry pumping system, as defined by the {0:1} character:

- If {0:1} = 0, release control.
- If {0:1} = 1, take control.

If any other module has control, the command is ignored by the dry pumping system.

### 5.4.3 Gas ballast command message (!D)

Send this command message to control the operation of gas ballast (if fitted), as follows:

- If {0:1} = 0, switch gas ballast off.
- If {0:1} = 1, switch gas ballast on.

### 5.4.4 Format mode command message (!F)

Send this command message to define the format of replies to query messages (see Section 5.3.1). The {0:1} character defines the required length of replies, as follows:

- If {0:1} = 0, short replies are requested.
- If {0:1} = 1, long replies are requested.

#### 5.4.5 Gate valve command message (!G)

Send this command message to control the operation of the gate valve (if fitted), as follows:

- If {0:1} = 0, close the gate valve.
- If {0:1} = 1, open the gate valve.

#### 5.4.6 Load-lock pump command message (!L)

Send this command message to control the operation of the load-lock pump (if fitted), as follows:

- If {0:1} = 0, switch off the load-lock pump.
- If {0:1} = 1, switch on the load-lock pump.

#### 5.4.7 Simulation mode command message (!M)

*Note:* When you send this message, all stored data is cleared: see [Section 5.5.1](#).

Send this command message to enter or exit simulation mode (see [Section 5.5](#)), as follows:

- If {0:1} = 0, exit simulation mode.
- If {0:1} = 1, enter simulation mode.

#### 5.4.8 Nitrogen supply command message (!N)

Send this command message to control the operation of the nitrogen supply (if fitted), as follows:

- If {0:1} = 0, switch off the nitrogen supply.
- If {0:1} = 1, switch on the nitrogen supply.

#### 5.4.9 On process command message (!O)

Send this command message to set or reset the On process flag, as follows:

- If {0:1} = 0, reset the On process flag.
- If {0:1} = 1, set the On process flag.

#### 5.4.10 Pump command message (!P)

Send this command message to control the operation of the dry pumping system, as follows:

- If {0:2} = 0, switch off the dry pumping system (Auto shut-down).
- If {0:2} = 1, switch on the dry pumping system.
- If {0:2} = 2, switch off the dry pumping system (Fast shut-down).

#### 5.4.11 Run til crash command message (!R)

Send this command message to select or deselect Run til crash, as follows:

- If {0:1} = 0, deselect Run til crash.
- If {0:1} = 1, select Run til crash.

### 5.4.12 Inlet purge command message (!U)

Send this command message to control the operation of the inlet purge (if fitted), as follows:

- If {0:1} = 0, switch off the inlet purge.
- If {0:1} = 1, switch on the inlet purge.

## 5.5 Simulation mode

### 5.5.1 Introduction

*Note:* When the Communications Module is first switched on, it automatically enters the normal mode.

The serial interface card can operate in one of two modes:

- In normal mode, query and command messages are associated with the dry pumping system to which the serial interface card is connected, as described in Section 5.3 and 5.4.
- In simulation mode, query and command messages can be sent to the serial interface card as in normal mode, but are associated with a 'simulated pumping system' in the serial interface card. In this mode, command messages do not affect the dry pumping system and replies to query messages contain information about the simulated pumping system, not the dry pumping system.

Use the simulation mode command message (see Section 5.4.6) to enter and exit simulation mode.

Note that the serial interface card maintains a common store data associated with the actual or simulated dry pumping system. When you exit simulation mode, this store is cleared; it may then take up to 45 seconds for the serial interface card to acquire the new data from the actual dry pumping system.

### 5.5.2 Simulated pumping system

When you send a query message in simulation mode, the information returned in the reply message depends on the selected simulated pumping system parameter, as shown in Table 14.

Other defaults in simulation mode are as follows:

- On process flag = reset.
- Run til crash = selected.
- Serial number = "Simulation<string>", where <string> is either a number of spaces, or a number of spaces followed by the issue status of the software in the Communications Module.

Table 14 - Simulated pumping system data

{parameter}	Description	{priority level}	{alarm type}	{bitfield status}	{value}
1*	Pump control				
2	Electrical supply voltage	0	0	0	2818
3	Dry pump phase current	0	0	0	44
4	Dry pump power	0	0	0	24
5	Voltage reading from dry pump thermistor	0	0	0	230
6	Imbalance in dry pump phase current	0	0	0	30
7	Mechanical booster pump phase current	0	0	0	91
8	Mechanical booster pump power	1	11	0	45
9	Voltage reading from mechanical booster pump thermistor	0	0	0	564

Table 14 - Simulated pumping system data

{parameter}	Description	{priority level}	{alarm type}	{bitfield status}	{value}
10	Imbalance in mechanical booster pump phase current	0	0	0	10
11*	Dry pump status				
12	Mechanical booster pump status	0	0	0	4
13	Gas module supply	0	0	0	4
14	Total running time	0	0	0	207
16	Hours on process	0	0	0	3
18	Process cycles	0	0	0	1
20	Electrical supply on/off cycles	0	0	0	52
21	Time to stop	0	0	0	75
31*	Gas module control				
32	Final stage purge nitrogen flow	0	0	0	462
35	Auxiliary nitrogen purge flow	0	0	0	190
39	Exhaust pressure	0	0	0	59
40	Shaft-seals purge pressure	0	0	0	397
45	Nitrogen supply status	0	0	0	4
46	Interstage purge status	0	0	0	3
47	Inlet purge status	0	0	0	1
48	Time for gas sensors to zero	0	0	0	68
51*	Sensor module control				
52	Analogue water flow	0	0	0	265
53	Active gauge pressure	0	0	0	2.1E-5
54	Mechanical booster pump motor temperature	0	0	0	3210
55	Dry pump motor temperature	1	13	2	1319
56	Exhaust temperature	0	0	0	4180
57	Dry pump body temperature	0	0	0	3536
58	Dry pump oil status	0	0	0	1
59	Mechanical booster pump oil status	0	0	0	1
60	Water flow status	0	0	0	1
111*	NIM (Network Interface Module)				
121*	Parallel (tool) interface module				
131	Parallel (tool) interface input status	0	15	0	0
140	Parallel (tool) interface output status	0	15	0	0
151*	Auxiliary interface Card				
160	Auxiliary interface input status	0	0	0	78
169	Auxiliary interface output status	0	0	0	24
172	Inverter current	0	0	0	7
173	Inverter power	0	0	0	6
174	Inverter speed	0	0	0	1000
175	Inverter torque	0	0	0	5
176	Inverter status	0	0	0	000F000F
245	GRC status	1	1	0	000F000F

\* These parameters can only be specified in ?I query messages.

## 6 Maintenance

### 6.1 Inspect the electrical connections

Do the following checks regularly when you maintain the dry pumping system:

- Check the Communications Module and ensure that it is securely fixed in place.
- Inspect the electrical cables and check that they are not damaged and have not overheated. Repair or replace any damaged or overheated cable.
- Inspect the electrical connections and check that they are secure. Tighten any loose connections.

### 6.2 Fault finding

#### 6.2.1 Error number reply messages

When the serial interface card acts on a command or query message, it sets the error number to indicate the success or failure of the message. The error numbers returned in the error reply message are shown in [Table 15](#).

Table 15 - Serial interface error numbers

Error Number	Meaning	Possible cause/action
0	No error	-
1	Invalid message	The message sent was not a valid query or command message.
2	Number not found	Part of a message (for example, {parameter}) was not found. Resend the message in the correct format.
3	Number Invalid	Part of a message was outside the valid range (for example the {0:1} digit in a command message was higher than 1).
4	Parameter's value not received	The corresponding sensor may be faulty or disconnected.  Alternatively, you have requested a parameter value too soon after you have connected or switched on the Communications Module or sending the !MO message. Wait to allow the parameter data to become available (this may take up to 45 seconds) then request the value again.
5	Command not possible	You have tried to take or release control, but another module has control of the dry pumping system. Release control from the other module, then try again.

#### 6.2.2 Determine the pumping system error number

For further information on some of the errors, meanings and recommended actions, you can refer to the corresponding warning or alarm message in the instruction manual supplied with the dry pumping system.

Each warning and alarm message has a pumping system error number. To determine which message(s) to refer to, calculate the error number from information in the serial interface card reply messages as follows:

error number = ({parameter} x 100) + {alarm type}

### 6.2.3 Serial communications problems

If the serial communications do not operate correctly, check the items shown in [Table 16](#).

**Table 16 - Serial communications fault finding**

Check	Action
Is the control equipment operating?	Ensure that the electrical supply to the control equipment is switched on and that the control equipment is switched on.
Are the communications cables connected?	Ensure that the communications cables are correctly connected to the dry pumping system and to the control equipment.
Are the cables wired correctly?	Ensure that the wires of the communications cables are correctly connected to the dry pumping system and the control equipment connectors. Refer to <a href="#">Table 2</a> for the RS232 connection details.
Is the control equipment configured correctly?	Ensure that the baud rate, parity and stop bits of the control equipment are correctly configured.
Are the cables too long?	Ensure that the communications cables are less than 10m long. If the communications cables are longer than 10m, ensure that the line-drivers are correctly incorporated into the communications cables.



---

## 7 Storage and Disposal

### 7.1 Storage

Replace any protective packing materials and store the Communications Module in clean dry conditions.

When required for use, install the Communications Module as described in [Section 3](#).

### 7.2 Disposal

Dispose of the Communications Module and any components safely in accordance with all local and national safety and environmental requirements.

## 8 Service, Spares and Accessories

### 8.1 Introduction

Edwards products, spares and accessories are available from Edwards companies in Belgium, Brazil, Canada, China, France, Germany, Israel, Italy, Japan, Korea, Singapore, Switzerland, United Kingdom, U.S.A and a world-wide network of distributors. The majority of these centres employ Service Engineers who have undergone comprehensive Edwards training courses.

Order spare parts and accessories from your nearest Edwards company or distributor. When you order, please state for each part required:

- Model and Item Number of your equipment.
- Serial number (if any).
- Item Number and description of the part.

### 8.2 Service

Edwards products are supported by a world-wide network of Edwards Service Centres. Each Service Centre offers a wide range of options including: equipment decontamination; service exchange; repair; rebuild and testing to factory specifications. Equipment which has been serviced, repaired or rebuilt is returned with a full warranty.

Your local Service Centre can also provide Edwards engineers to support on-site maintenance, service or repair of your equipment.

For more information about service options, contact your nearest Service Centre or other Edwards company.

### 8.3 Spares

Spare	Item Number
Module connector cable	D372-07-603
Terminator plug	A532-20-050

### 8.4 Accessories

Accessory	Item Number
Module connector cable (3 m)	D372-07-591
Module connector cable (5 m)	D372-07-592
Module connector cable (10 m)	D372-07-595