

# Instruction Manual

## EMF Adjustable Gas Ballast Oil Drain Kit for RV3 to RV12 Pumps

Description	Item Number
EMF adjustable Gas Ballast Oil Drain Kit for RV3 to RV12 Pumps	A505-23-000

Chemtech Scientific provides access to this content as a courtesy.  
We do not own the content contained in this document.  
All rights and credit go directly to its rightful owners.  
[www.chemtechsci.com](http://www.chemtechsci.com)  
Call us at: 484-424-9415



# Contents

Section	Page
1 Introduction .....	1
1.1 Scope and definitions .....	1
1.2 Description .....	1
2 Installation .....	3
2.1 Unpack and Inspect .....	3
2.2 Fit the Oil Drain Kit .....	3
2.3 Select the gas ballast flow rate (optional) .....	5
3 Maintenance .....	9
4 Storage and disposal .....	11
4.1 Storage .....	11
4.2 Disposal .....	11
5 Service and spares .....	13
5.1 Introduction .....	13
5.2 Service .....	13
5.3 Spares .....	13

For return of equipment, complete the HS Forms at the end of this manual.

# Illustrations

Figure	Page
1 Side view (pump inlet-flange omitted for clarity) .....	4
2 Adjust the gas ballast flow rate .....	6
3 Parts sectional view of the oil return assembly .....	7

# 1 Introduction

## 1.1 Scope and definitions

This manual provides installation, operation and maintenance instructions for the Edwards EMF Gas Ballast Oil Drain Kit for RV3 to RV12 Pumps. You must use the Oil Drain Kit as specified in this manual. Read this manual before you install and operate the Oil Drain Kit.

## 1.2 Description

**Note:** *In normal operation, oil will not be visible in the sight-glasses of the oil mist filter.*

The Oil Drain Kit is designed for use with an RV3, RV5, RV8 or RV12 pump (fitted with an EMF oil mist filter) which operates continuously with gas ballast switched on. You cannot use the Oil Drain Kit if you want to introduce a purge gas into the RV pump. If you want to introduce a purge gas into the RV pump, you must fit a Gas Ballast Adaptor to the pump (refer to the RV pump instruction manual) and oil cannot be returned from the pump.

When fitted, the Oil Drain Kit continuously returns oil trapped in the oil mist filter to the pump. This reduces oil loss from the pump and minimises the need to check the pump oil-level and to refill the pump with oil.

At high inlet pressures (above 200 mbar,  $2 \times 10^4$  Pa), the Oil Drain Kit will not work correctly. If you want to return oil to the pump when the pump is operated at high inlet pressures, contact your supplier or Edwards for advice.

The Oil Drain Kit is not suitable for use with an RV pump which is used in hazardous processes.

## 2 Installation

### 2.1 Unpack and Inspect

Remove all packaging materials and protective covers and check the Oil Drain Kit. If the Oil Drain Kit is damaged, notify your supplier and the carrier in writing within three days. You must state the Item Number of the Oil Drain Kit together with your order number and your supplier's invoice number. Return all packaging materials for inspection. Do not use the Oil Drain Kit if it is damaged.

Check that your package contains the items listed in Table 1. If any item is missing, notify your supplier in writing within three days.

If the Oil Drain Kit is not used immediately, replace the protective covers. Store the Oil Drain Kit in suitable conditions, as described in Section 4.1.

**Table 1 - Checklist of components**

Qty	Description	Check (3)
1	Oil return assembly	
1	Drain adaptor	
1	Restrictor	
1	Flexible oil-return tube	
2	Hose clips	
1	'O' ring: Ø14.6 x 2.4	
1	'O' ring: Ø21.5 x 3.0	

### 2.2 Fit the Oil Drain Kit

Where necessary, refer to the instruction manuals supplied with your pump and oil mist filter when you fit the Oil Drain Kit.

1. Switch off the pump and allow it to cool to a safe temperature. Isolate the pump from the electrical supply, so that it cannot be operated accidentally.
2. Remove the drain-plug from the oil mist filter and drain the oil from the oil mist filter. Retain the drain-plug for future use.
3. Refer to Figure 1. Fit the drain adaptor (8) to the oil mist filter (1).
4. Turn the gas ballast control on the pump to the high flow position (position II). Push the control down (against the spring), turn the control anticlockwise to release it and remove the control from the pump. Leave the spring in position in the gas ballast inlet.
5. Refer to Figure 3. Fit the two 'O' rings (6, 7) to the oil return assembly.
6. Refer to Figure 1. If you have an RV3 or RV5 pump, lift the handle. Fit the oil return assembly (5) to the gas ballast inlet on the pump, push the assembly down (against the spring) and turn the adaptor clockwise to secure it on the pump. When the oil return assembly is correctly secured to the pump, the nozzle (4) should be over the gas ballast '0' position marked on the top of the pump: see detail B.

Figure 1 - Side view (pump inlet-flange omitted for clarity)

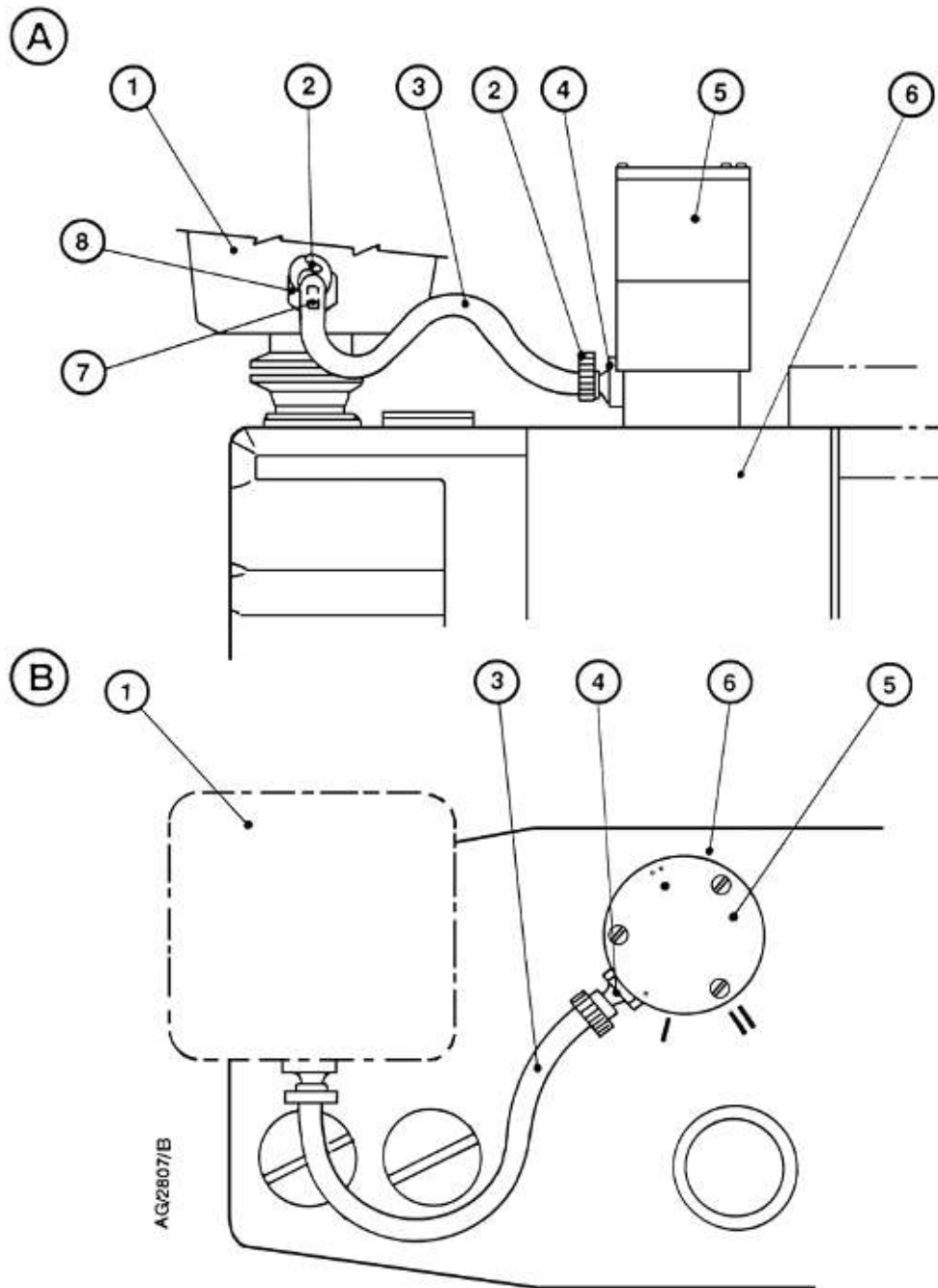

- |                             |                        |
|-----------------------------|------------------------|
| 1. EMF Oil mist filter      | 5. Oil return assembly |
| 2. Hose clip                | 6. RV pump             |
| 3. Flexible oil return tube | 7. Restrictor          |
| 4. Nozzle                   | 8. Drain adaptor       |

7. Cut a suitable length from the flexible oil-return tube. The routing of the tube (3) must be approximately as shown in Figure 1. When fitted, the tube must not be taut and there must be no tight bends in the tube. Ensure that the ends of the oil-return tube are free of burrs and that they are squarely cut (that is, the cut faces are at a right-angle to the length of the tube).
8. Fit the restrictor (7) into one end of the tube as shown in Figure 1, then fit the end of the tube (3) to the drain adaptor (8) on the oil mist filter.
9. Fit the other end of the tube to the nozzle (4) on the oil return assembly (5).
10. Use the hose clips (2) to secure the ends of the flexible oil return tube (3).
11. Reconnect the pump to the electrical supply.

### 2.3 Select the gas ballast flow rate (optional)

**Note:** *If required, use the procedure below to change the gas ballast flow rate after you have used the Oil Drain Kit; you must switch off the pump, allow it to cool and isolate it from the electrical supply before you use the following procedure.*

The Oil Drain Kit is supplied configured so that the gas ballast flow rate is equivalent to that with the gas ballast control on the pump in position 'II'. If required, you can adjust the gas ballast flow rate; use the following procedure:

1. Refer to Figure 2. Undo and remove the three screws (1) which secure the restrictor plate (5); do not dismantle the assembly.
2. The restrictor plate (5) has circular indentations (2 and 3); the position of these indentations with respect to the indentation (4) on the oil return assembly identifies the gas ballast flow setting. Turn the restrictor plate to the required position:
  - To select no gas ballast flow (equivalent to the gas ballast control on the pump in position '0'), turn the restrictor plate so that none of the indentations (2 and 3) are aligned with the indentation (4) on the oil return assembly.
  - To select low gas ballast flow (equivalent to the gas ballast control on the pump in position 'I'), turn the restrictor plate so that the single indentation (2) is aligned with the indentation (4) on the oil return assembly.

Figure 2 - Adjust the gas ballast flow rate

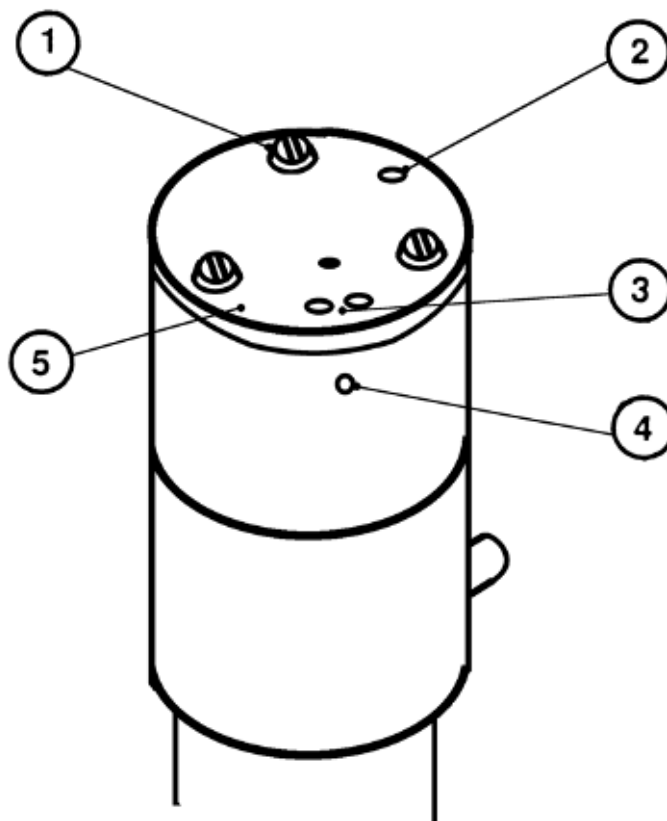

1. Screws (3 off)
2. Indentation (low gas ballast flow position)
3. Indentations (high gas ballast flow position)
4. Indentation
5. Restrictor plate

- To select high gas ballast flow (equivalent to the gas ballast control on the pump in position 'II'), turn the restrictor plate so that the two indentations (3) are aligned with the indentation (4) on the oil return assembly.

3. Refit and tighten the three screws (1)

Figure 3 - Parts sectional view of the oil return assembly

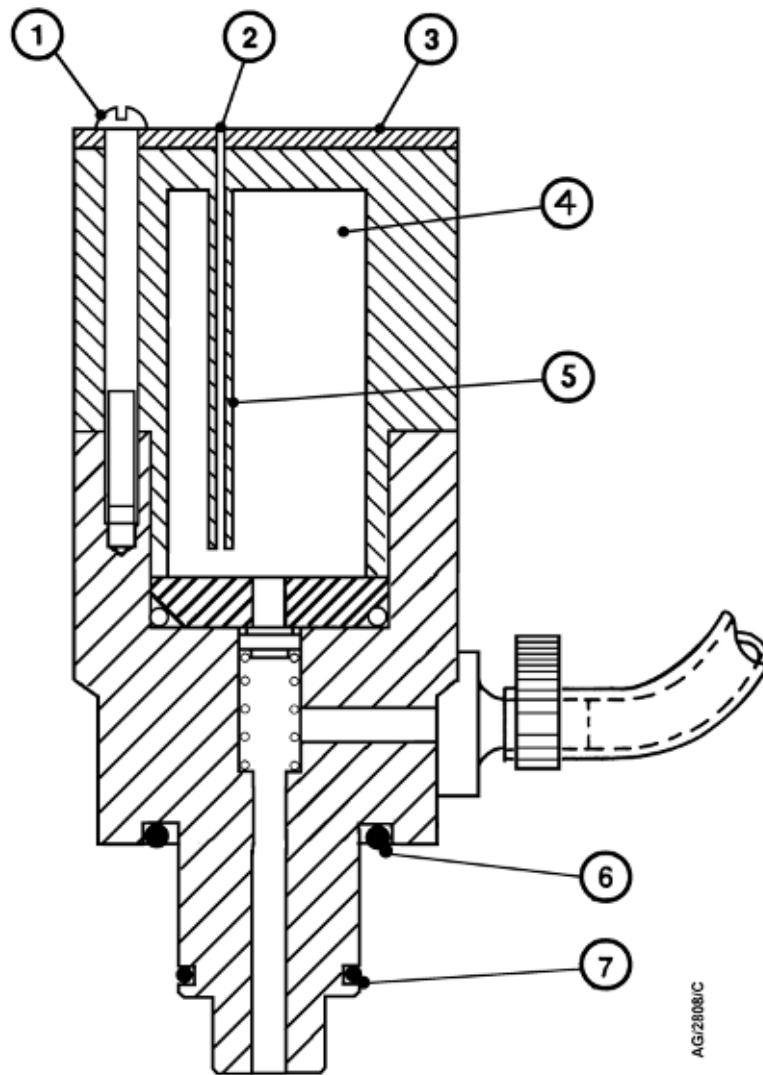

- |                      |  |
|----------------------|--|
| 1. Screw             | 5. Silencer tube                           |
| 2. Air inlet         | 6. 'O' ring: $\varnothing 21.5 \times 3.0$ |
| 3. Restrictor plate  | 7. 'O' ring: $\varnothing 14.6 \times 2.4$ |
| 4. Expansion chamber |  |

AG/2808/C



## 3 Maintenance

Regularly inspect the Oil Drain Kit and do the following checks:

- Check that the oil return assembly is securely fitted to the pump.
- Check that the oil return tube is securely fitted to the oil return assembly and to the oil mist filter.
- Check that there are no blockages in the Oil Drain Kit.
- Check that the Oil Drain Kit operates correctly.

Refer to Figure 3. If one or both of the air inlets (2) on the restrictor plate (3) of the oil return assembly are blocked:

1. Switch off the pump and allow it to cool to a safe temperature. Isolate the pump from the electrical supply, so that it cannot be operated accidentally.
2. Undo and remove the three screws (1) which secure the restrictor plate (3) and remove the plate from the oil return assembly.
3. Use a suitable tool to remove the blockage from the air inlet (2).
4. Refit the restrictor plate (3) to the oil return assembly and secure with the three screws (1), then reconnect the pump to the electrical supply.

Refer to Figure 1. If the restrictor (7) is blocked:

1. Switch off the pump and allow it to cool to a safe temperature. Isolate the pump from the electrical supply, so that it cannot be operated accidentally.
2. Undo and remove the hose clip (2) on the oil mist filter end of the oil return tube (3), then remove the end of the oil return tube from the drain adaptor (8) on the oil mist filter (1).
3. Remove the restrictor (7) from the oil return tube and remove the blockage from the restrictor.
4. Refit the restrictor (7) in the end of the oil return tube (3), fit the end of the oil return tube to the drain adaptor (8) on the oil mist filter, then use the hose clip (2) to secure the end of the oil return tube.
5. Reconnect the pump to the electrical supply.

## 4 Storage and disposal

### 4.1 Storage

Store the Oil Drain Kit in cool, dry conditions until required for use.

When required, install the Oil Drain Kit as described in Section 2.

### 4.2 Disposal

Dispose of pump oil, the Oil Drain Kit and any components removed from it safely in accordance with all local and national safety and environmental requirements.

## 5 Service and spares

### 5.1 Introduction

Edwards products, spares and accessories are available from Edwards companies in Belgium, Brazil, Canada, France, Germany, Hong Kong, Italy, Japan, Korea, Switzerland, United Kingdom, U.S.A and a world-wide network of distributors. The majority of these centres employ Service Engineers who have undergone comprehensive Edwards training courses.

Order spare parts and accessories from your nearest Edwards company or distributor. When you order, state for each part required:

- Model and Item Number of your equipment
- Serial number
- Item Number and description of part.

### 5.2 Service

Edwards products are supported by a world-wide network of Edwards Service Centres. Each Service Centre offers a wide range of options including: equipment decontamination; service exchange; repair; rebuild and testing to factory specifications. Equipment which has been serviced, repaired or rebuilt is returned with a full warranty.

Your local Service Centre can also provide Edwards engineers to support on-site maintenance, service or repair of your equipment.

For more information about service options, contact your nearest Service Centre or other Edwards company.

### 5.3 Spares

The Service Kit contains all items that you may need to replace on the Oil Drain Kit. Replace items as necessary when you do the annual overhaul of the RV pump.

Spare	Item Number
Service Kit	A505-23-825