

Instruction Manual

Vacuum Interlock Switch IS16K

Description	Item Number
Vacuum Interlock Switch IS16K	D059-14-000

Chemtech Scientific provides access to this content as a courtesy.
We do not own the content contained in this document.
All rights and credit go directly to its rightful owners.
www.chemtechsci.com
Call us at: 484-424-9415



Contents

Section	Page
1 INTRODUCTION	1
1.1 Scope and definitions	1
1.2 Description	1
2 TECHNICAL DATA	2
2.1 Operating conditions	2
2.2 Performance	2
2.3 Mechanical data	2
2.4 Electrical data	2
2.5 Product item number	3
3 INSTALLATION	4
3.1 Unpacking and inspection	4
3.2 General	4
3.3 Connection to the Vacuum System	4
3.4 Connection to the Electrical Circuit	4
4 OPERATION	6
4.1 Adjustment	6
5 MAINTENANCE	7
6 STORAGE AND DISPOSAL	8
6.1 Storage	8
6.2 Disposal	8
Index	9

For return of equipment, complete the HS Forms at the end of this manual.

Illustrations

Figure	Page
1 Vacuum switch plug connections	5
2 Dimensions of VS16K vacuum switch	7

Tables

Table	Page
1 Maximum switch ratings	2

1 INTRODUCTION

1.1 Scope and definitions

This manual provides installation, operation and maintenance instructions for the Edwards IS16K Vacuum Interlock Switch. Read this manual before attempting to install and operate the IS16K.

This manual contains essential safety information which supplements the safety features of the IS16K. Safety procedures are highlighted as WARNING and CAUTION instructions. You must obey these instructions. The use of WARNINGS and CAUTIONS is defined below.



WARNING

Warnings are given where failure to observe the instruction could result in injury or death to people.

CAUTION

Cautions are given where failure to observe the instruction could result in damage to the equipment, associated equipment and process.

1.2 General description

The Edwards IS16K Vacuum Interlock Switch is designed for applications where the electrical circuits within the vacuum chamber must be de-energised when the vacuum system is let up to atmosphere.

Typical applications would be the interlocking of H.T. and R.F. power supplies on vacuum coating systems. The interlocking switch consists of a positive break microswitch operated by a snap action diaphragm to ensure rapid separation of the microswitch contacts.

The diaphragm is enclosed within the vacuum switch housing which is surrounded by atmospheric pressure and is coupled to the vacuum system by a NW16 flange. The absolute switch point pressure will therefore vary by the same amount as the atmospheric pressure.

The set-point is non-adjustable and cannot be tampered with.

2 TECHNICAL DATA

2.1 Operating conditions

Temperature range - operating	-5°C to 40°C
Temperature range - storage	-20°C to 70°C
Relative humidity (non condensing)	10 to 90%
Maximum operating altitude	3000 m
Installation category (IEC1010)	2 (IEC664/664A)
Pollution category (IEC1010)	2
Enclosure rating	IP40

2.2 Performance

Set-point	Within the range 250 to 500 mbar below atmospheric pressure
Maximum switch point differential	100 mbar
Leak rate	$< 1 \times 10^{-9}$ mbar litre/sec ⁻¹
Maximum overpressure	1 bar gauge (2 bar absolute)

2.3 Mechanical data

Weight (unpacked)	0.5 kg
Weight (packed)	0.6 kg
Vacuum connection	NW16 Flange
Volume added to vacuum system	7 cm ³
Materials exposed to vacuum system	Stainless steel and Armco 17/7PH

2.4 Electrical data

Electrical connection	mPm 283 plug
Accessory supplied	mPm 183 mating electrical socket

Maximum switch ratings for different loads and voltages:

Table 1 - Maximum switch ratings

Volts a.c. 50/60Hz	Resistive Load Amps	Tungsten Lamp Load Amps	Inductive Load Amps
125	10	5.0	10
250	10	5.5	10

2.5 Product item number

Description	Item Number
Vacuum Interlock Switch	D059-14-000

3 INSTALLATION

3.1 Unpacking and inspection

Remove all packing materials and protective covers and check the IS16K for damage. If the IS16K is damaged, notify your supplier and the carrier in writing within three days; state the Item Number of the IS16K together with your order number and your supplier's invoice number. Retain all packing materials for inspection. Do not use the IS16K.

3.2 General

The vacuum switch should be mounted as close as possible to the point at which the pressure is to be measured. Use a short branch tube with an internal diameter no less than that of the switch vacuum connection. Long, narrow and angled connections can cause significant errors.

This equipment is not protected from dripping water from above, unless mounted with the vacuum flange pointing downwards.

3.3 Connection to the Vacuum System



WARNING

Do not allow the internal pressure to be higher than 1 bar gauge (2 bar absolute). If the pressure in your system can be higher than 1 bar gauge, you must fit a suitable pressure relief valve. Overpressure of the switch could cause injury to persons.

The vacuum switch may be mounted in any orientation but mounting with the vacuum switch vertical will prevent the possibility of debris falling into the vacuum port and affecting the performance of the switch.

3.4 Connection to the Electrical Circuit



WARNING

Ensure that the electrical installation of the Vacuum Switch conforms with your local and national safety requirements. It must be connected to a suitably fused and protected electrical supply and a suitable earth point.

CAUTION

Ensure that the circuit connected to the vacuum switch is suitably fused to prevent the switch contact rating being exceeded. The fuse rating must not exceed 10 amps.



WARNING

If, in your application, failure of this switch could lead to a safety hazard, it is recommended that the switch should be wired in series with another interlocking device, for example chamber lid microswitch, to provide a double level of protection.

Connect the vacuum switch to the equipment using the four pole mPm connector supplied. The contacts on this connector are internally wired as follows:-

Figure 1 - Vacuum switch plug connections



Earth connection.

Com

Common

Lo

Contact made when system pressure is lower than set-point.

3 = Com

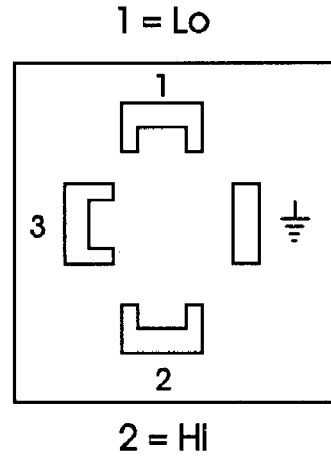

CAUTION

To ensure that the socket cable gland strain relief is effective a cable with a minimum diameter of 6 mm must be used.

Select a three or four core cable of a rating suitable for the power supply to be switched. One core should be coloured green/yellow for the earth connection.

Thread the cable through the cable gland on the mPm socket cover and connect to the appropriate terminals as shown on the diagram.

Tighten the cable gland and connect the socket to the switch using the sealing gasket and locking screw provided.

4 OPERATION

4.1 Adjustment

The IS16K Vacuum interlock switch is pre-set to operate in the range of 250 to 500 mbar below atmospheric pressure. No user adjustment is available.

Figure 2 - Dimensions of IS16K vacuum switch

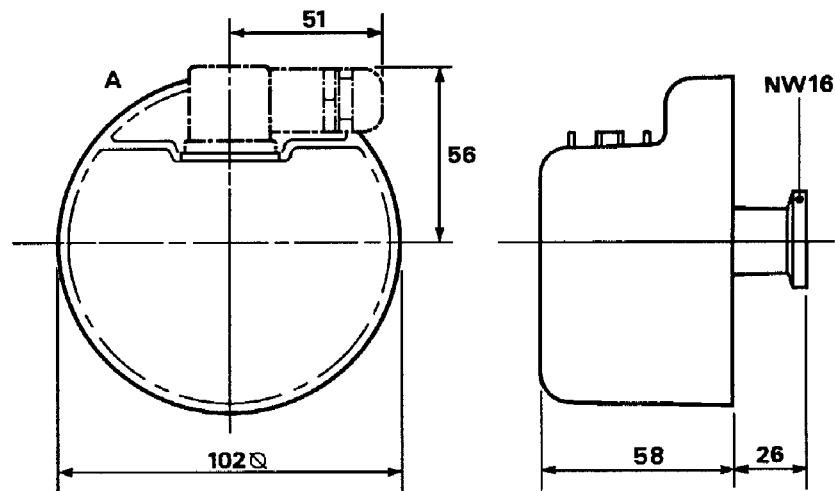

5 MAINTENANCE



WARNING

Ensure that maintenance is done by a suitably trained and supervised technician. Obey your local and national safety requirements.

To ensure correct operation this vacuum switch should be tested once per year or every 10 000 cycles whichever is sooner.

To test for correct operation proceed as follows:

1. Disconnect the electrical supply from the vacuum switch.
2. Connect an electrical continuity meter between the pin marked 'com' and the pin marked 'Lo'. Refer to Figure 1 for pin connections.
3. With the IS16K at atmosphere verify that the meter reads open circuit.
4. Reduce the pressure to below 500 mbar (as measured on a vacuum gauge) and check that the meter reads short circuit.
5. Raise the pressure to above 500 mbar and check that the meter reads open circuit again.

The outer surfaces of the switch may be cleaned by wiping with a dry cloth. Avoid the use of solvents that may attack the moulded cover.

This product contains no user serviceable parts.

6 STORAGE AND DISPOSAL

6.1 Storage

Store in a cool dry place. Do not exceed the limits specified in [Section 2](#).

6.2 Disposal

Dispose of the IS16K in accordance with any local or national safety requirements.

Particular care must be taken if the switch has been used in a hazardous environment.

Index

A

Adjustment5

C

Connection to the Electrical Circuit3

Connection to the Vacuum System3

E

Electrical data2

G

General3

General description1

I

INSTALLATION3

Introduction1

M

MAINTENANCE6

Mechanical data2

O

Operating conditions2

OPERATION5

P

Performance2

Product item number2

S

Scope and definitions1

STORAGE AND DISPOSAL7

T

TECHNICAL DATA2

U

Unpacking and inspection3

Return of Edwards Equipment - Procedure

INTRODUCTION

Before returning your equipment, you must warn Edwards if substances you used (and produced) in the equipment can be hazardous. This information is fundamental to the safety of our Service Centre employees and will determine the procedures employed to service your equipment.

Complete the Declaration (HS2) and send it to Edwards before you dispatch the equipment. It is important to note that this declaration is for Edwards internal use only, and has no relationship to local, national or international transportation safety or environmental requirements. As the person offering the equipment for shipment, it is your responsibility to ensure compliance with applicable laws.

GUIDELINES

- Equipment is '**uncontaminated**' if it has not been used, or if it has only been used with substances that are not hazardous. Your equipment is '**contaminated**' if it has been used with any substances classified as hazardous under EU Directive 67/548/EEC (as amended) or OSHA Occupational Safety (29 CFR 1910).
- If your equipment has been used with radioactive substances, biological or infectious agents, mercury, polychlorinated biphenyls (PCB's), dioxins or sodium azide, you must decontaminate it before you return it to Edwards. You must send independent proof of decontamination (for example a certificate of analysis) to Edwards with the Declaration (HS2). Phone Edwards for advice.
- If your equipment is contaminated, you must either:
 - Remove all traces of contamination (to the satisfaction of laws governing the transportation of dangerous/hazardous substances).
 - Or, properly classify the hazard, mark, manifest and ship the equipment in accordance with applicable laws governing the shipment of hazardous materials.

Note: Some contaminated equipment may not be suitable for airfreight.

PROCEDURE

1. Contact Edwards and obtain a Return Authorisation Number for your equipment.
2. Complete the Return of Edwards Equipment - Declaration (HS2).
3. If the equipment is contaminated, you must contact your transporter to ensure that you properly classify the hazard, mark, manifest and ship the equipment, in accordance with applicable laws governing the shipment of contaminated/hazardous materials. As the person offering the equipment for shipment, it is your responsibility to ensure compliance with applicable law. **Note: Equipment contaminated with some hazardous materials, such as semiconductor by-products, may not be suitable for airfreight - contact your transporter for advice.**
4. Remove all traces of hazardous gases: pass an inert gas through the equipment and any accessories that will be returned to Edwards. Where possible, drain all fluids and lubricants from the equipment and its accessories.
5. Seal up all of the equipment's inlets and outlets (including those where accessories were attached) with blanking flanges or, for uncontaminated product, with heavy gauge tape.
6. Seal equipment in a thick polythene/polyethylene bag or sheet.
7. If the equipment is large, strap the equipment and its accessories to a wooden pallet. If the equipment is too small to be strapped to a pallet, pack it in a suitable strong box.
8. E-mail via scan, fax or post a copy of the original with signature of the Declaration (HS2) to Edwards. The Declaration must arrive before the equipment.
9. Give a copy of the Declaration (HS2) to the transporter. You must tell your transporter if the equipment is contaminated.
10. Seal the original Declaration in a suitable envelope: attach the envelope securely to the outside of the equipment package, in a clear weatherproof bag.
WRITE YOUR RETURN AUTHORISATION NUMBER CLEARLY ON THE OUTSIDE OF THE ENVELOPE OR ON THE OUTSIDE OF THE EQUIPMENT PACKAGE.

Return of Edwards Equipment - Declaration

Return Authorisation Number: _____

You must:

- Know about all of the substances which have been used and produced in the equipment before you complete this Declaration
- Read the Return of Edwards Equipment - Procedure (HS1) before you complete this Declaration
- Contact Edwards to obtain a Return Authorisation Number and to obtain advice if you have any questions
- Send this form to Edwards before you return your equipment as per the procedure in HS1

SECTION 1: EQUIPMENT

Manufacturer's Product Name _____

Manufacturer's Part Number _____

Manufacturer's Serial Number _____

Has the equipment been used, tested or operated?

YES Go to Section 2 NO Go to Section 4

IF APPLICABLE:

Tool Reference Number _____

Process _____

Failure Date _____

Serial Number of Replacement Equipment _____

SECTION 2: SUBSTANCES IN CONTACT WITH THE EQUIPMENT

Are any substances used or produced in the equipment:

- Radioactive, biological or infectious agents, mercury, poly chlorinated biphenyls (PCBs), dioxins or sodium azide? (if YES, see Note 1) YES NO
- Hazardous to human health and safety? YES NO

Note 1: Edwards will not accept delivery of any equipment that is contaminated with radioactive substances, biological/infectious agents, mercury, PCB's, dioxins or sodium azide, unless you:

- Decontaminate the equipment
- Provide proof of decontamination

YOU MUST CONTACT EDWARDS FOR ADVICE BEFORE YOU RETURN SUCH EQUIPMENT

SECTION 3: LIST OF SUBSTANCES IN CONTACT WITH THE EQUIPMENT

Substance name	Chemical Symbol	Precautions required (for example, use protective gloves, etc.)	Action required after a spill, leak or exposure

SECTION 4: RETURN INFORMATION

Reason for return and symptoms of malfunction: _____

If you have a warranty claim: • who did you buy the equipment from? _____

• give the supplier's invoice number _____

SECTION 5: DECLARATION

Print your name: _____ Print your job title: _____

Print your organisation: _____

Print your address: _____

Telephone number: _____ Date of equipment delivery: _____

I have made reasonable enquiry and I have supplied accurate information in this Declaration. I have not withheld any information, and I have followed the Return of Edwards Equipment - Procedure (HS1).

Signed: _____ Date: _____

Note: Please print out this form, sign it and return the signed form as hard copy.