

Instruction Manual

Industrial Active Inverted Magnetron Gauge



| Description | Item Number |
|---------------|-------------|
| AIM-SI1-NW25 | D146-71-000 |
| AIM-XI1-NW25 | D146-72-000 |
| AIM-SLI1-NW25 | D146-74-000 |
| AIM-XLI1-NW25 | D146-75-000 |

Chemtech Scientific provides access to this content as a courtesy.
We do not own the content contained in this document.
All rights and credit go directly to its rightful owners.
www.chemtechsci.com
Call us at: 484-424-9415



Contents

| Section | Page |
|----------|--|
| 1 | Introduction 1 |
| 1.1 | Scope and definitions 1 |
| 1.2 | General description 1 |
| 1.3 | Gas dependency 2 |
| 2 | Technical data 3 |
| 2.1 | Mechanical data 3 |
| 2.2 | Performance, operating and storage conditions 3 |
| 2.3 | Electrical data 3 |
| 2.4 | Error monitoring 4 |
| 2.5 | Materials exposed to vacuum 4 |
| 3 | Installation 5 |
| 3.1 | Unpack and inspect 5 |
| 3.2 | Fit the AIM gauge to the vacuum system 5 |
| 3.3 | Electrical connection 5 |
| 3.3.1 | Connect to Edwards controllers or AGD display 5 |
| 3.3.2 | Connect to your own supply and control equipment 6 |
| 4 | Operation 9 |
| 4.1 | Safety 9 |
| 4.2 | Enable and disable the AIM gauge 9 |
| 4.3 | Pressure measurement 9 |
| 4.4 | Set-point 10 |
| 5 | Maintenance 13 |
| 5.1 | Introduction 13 |
| 5.2 | Replace the body tube 13 |
| 5.2.1 | Remove the AIM gauge from the vacuum system 13 |
| 5.2.2 | Fit the new body tube 13 |
| 5.2.3 | Refit the AIM gauge to the vacuum system 13 |
| 5.3 | Replace the electrode assembly 14 |
| 5.4 | Replace the electronics and magnet housing 14 |
| 5.5 | Clean the internal components 15 |
| 5.6 | Fault finding 15 |
| 6 | Storage and disposal 17 |
| 6.1 | Storage 17 |
| 6.2 | Disposal 17 |
| 7 | Spares and accessories 19 |
| 7.1 | Introduction 19 |
| 7.2 | Spares 19 |
| 7.3 | Accessories 19 |
| | Index 21 |

For return of equipment, complete the HS Forms at the end of this manual.

Illustrations

| Figure | Page |
|--------|---|
| 1 | General view of the AIM gauge (showing the NW25 flange) 2 |
| 2 | Dimensions (mm) 4 |
| 3 | Schematic diagram of typical electrical connections 6 |
| 4 | Exploded view of the AIM gauge tube assembly 15 |

Tables

| Table | Page |
|-------|--|
| 1 | Pins on the AIM gauge electrical connector socket 7 |
| 2 | Pressure and voltage characteristics for nitrogen and dry air 10 |

1 Introduction

1.1 Scope and definitions

This manual provides installation, operation, maintenance and storage instructions for the Edwards Industrial Active Inverted Magnetron Gauge. You must use the gauge as specified in this manual.

Read this manual before you install and operate the gauge. Important safety information is highlighted as WARNING and CAUTION instructions; you must obey these instructions. The use of WARNINGS and CAUTIONS is defined below.



WARNING

Warnings are given where failure to observe the instruction could result in injury or death to people.

CAUTION

Cautions are given where failure to observe the instruction could result in damage to the equipment, associated equipment and process.

Throughout this manual, page, figure and table numbers are sequential.

The units used throughout this manual conform to the SI international system of units of measurement.

The following symbol appears on the AIM Gauge:



Edwards offer European customers a recycling service.

1.2 General description

The AIM Gauge, shown in [Figure 1](#), is an inverted magnetron gauge head and gauge controller in a single compact unit. The gauge operates as a cold cathode ionisation gauge, in which the pressure is measured indirectly as function of the current which flows in a Townsend discharge maintained in the body tube.

The measurement range of the gauge is 1×10^{-8} to 1×10^{-2} mbar (AIM-SI1/AIM-SLI1) and 1×10^{-9} to 1×10^{-2} mbar (AIM-XI1 /AIM-XLI1). The AIM Gauge vacuum connection is a NW25 flange.

The AIM Gauge requires a 13.5 to 36 V d.c. power supply; it has a 2 to 10 V d.c. analogue output which is related to pressure. The AIM Gauge is compatible with all of the Edwards TIC (Turbo Instrument Controller), ADD (Active Digital Display) and with the appropriate versions of the Edwards AGD's (Active Gauge Displays). Alternatively, you can read the AIM Gauge output signal with a voltmeter or analogue-to-digital converter.

We recommend that you do not operate the AIM Gauge unless the pressure in the vacuum system is 1×10^{-2} mbar or lower. A gauge enable signal is used to control the operation of the AIM Gauge; refer to [Section 4.2](#) for more information.

An 8-way electrical connector socket on the AIM Gauge ([Figure 1](#), item 7) is used to connect the AIM Gauge to your TIC, ADD, AGD or electrical supply and voltmeter. Electrical cables fitted with suitable connector plugs are available as accessories.

A gauge identification signal is available on the electrical connector; this signal is used by Edwards Controllers to identify which type of Active Gauge is connected.

The AIM Gauge has a set-point facility; the set-point signal is an open drain transistor (FET) output, which is on when the pressure measured by the Gauge is below a pre-set pressure. You can adjust the pressure at which the set-point output goes on; refer to [Section 4.4](#).

Note: If you use an Edwards TIC Controller, ADD Controller or AGD Display, the AIM Gauge set-point output signal is not used.

1.3 Gas dependency

The ionisation of the gas in the vacuum system is dependent on both the pressure and the physical properties of the gas. Therefore, the output signal of the AIM Gauge is gas dependent.

The output signal voltage to pressure conversions in Section 4.3 apply for nitrogen and dry air.

Calibration graphs for use with argon, neon, krypton, helium and carbon dioxide are available on request; contact your supplier or Edwards.

Figure 1 - General view of the AIM gauge (showing the NW25 flange)

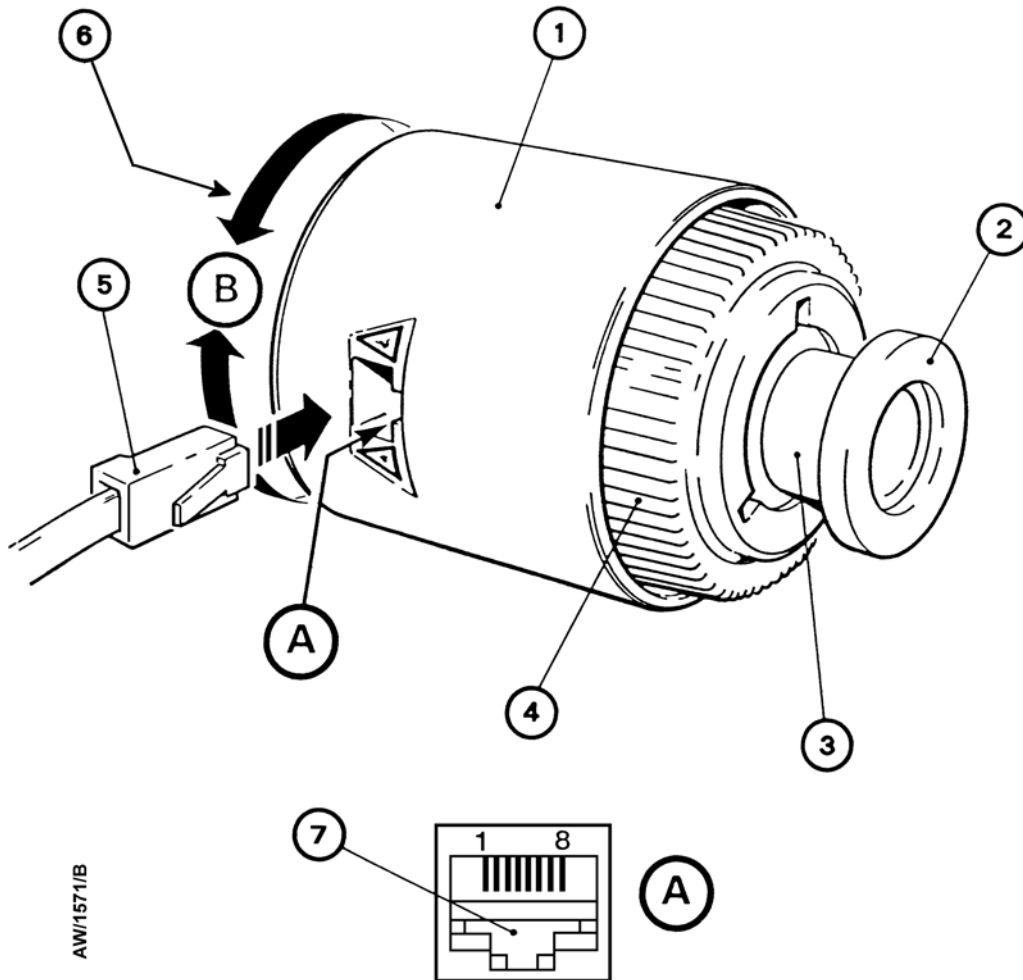

- 1. End-cap
- 2. Vacuum flange
- 3. Body tube
- 4. Magnet housing
- 5. Cable connector plug
- 6. Set-point potentiometer (on end of item 1)
- 7. AIM Gauge connector socket

AW1571/B

2 Technical data

2.1 Mechanical data

| | |
|----------------------|--------------------|
| Dimensions | See Figure 2 |
| Mass | 840 g |
| Volume of gauge tube | 26 cm ³ |
| Enclosure rating | IP40 |

2.2 Performance, operating and storage conditions

| | |
|------------------------------|--|
| Ambient temperature | |
| Operation | 5 to 60°C |
| Storage | 0 to 70°C |
| Ambient humidity (operation) | 10 to 90% (non condensing) |
| Maximum operating altitude | 2000 m |
| Maximum internal pressure | 10 bar absolute (9 bar gauge) |
| Pressure measurement range | 1 x 10 ⁻⁸ to 1 x 10 ⁻² mbar (AIM-SI1/AIM-SLI1) 1 x 10 ⁻⁹ to 1 x 10 ⁻² mbar (AIM-XI1/AIM-XLI1) |
| Pollution category | EN61010 Category 2 |

2.3 Electrical data

| | |
|---------------------------------------|---|
| Voltage | +13.5 to +36 V d.c. |
| Max voltage ripple | 1 V peak to peak |
| Max source resistance | 50 Ω |
| Max power consumption | 2 W |
| Electrical connector | FCC68/RJ45 type, 8-way |
| Pressure output signal | |
| Range | 2 ≤ output ≤ 10 V d.c. |
| Error range | output < 2 V d.c. or output > 10 V d.c. |
| Impedance | 0.1 Ω |
| Min load impedance | 10 kΩ |
| Max current source | 1 mA |
| Gauge enable | |
| Control sense | Active low |
| Active level | < 1.3 V |
| Control impedance | 12 kΩ pull up to positive supply |
| Set-point output external load rating | 40 V d.c., 100 mA max |
| Set-point trip level | |
| Range | 1.8 to 10.0 V |
| Minimum load impedance | 200 kΩ |
| Hysteresis | 500 mV |

| | |
|---------------------------------|--|
| Back EMF suppression diode* | |
| Min. surge rating | 1 A |
| Min. reverse voltage rating | 100 V |
| Gauge identification resistance | 100 k Ω \pm 2% AIM-SI1/AIM-SLI1 110 k Ω \pm 2% AIM-XI1/AIM-XLI1 |

* Required when you use an external d.c. relay connected to the set-point output.

2.4 Error monitoring

The set-point output is switched off:

- for 0.5 seconds during gauge switch on
- when pressure output signal voltage < 1.8 V

2.5 Materials exposed to vacuum

- Stainless steel (AISI 304, 416 and 347)
- Fluoroelastomer
- Soda lime glass

Figure 2 - Dimensions (mm)

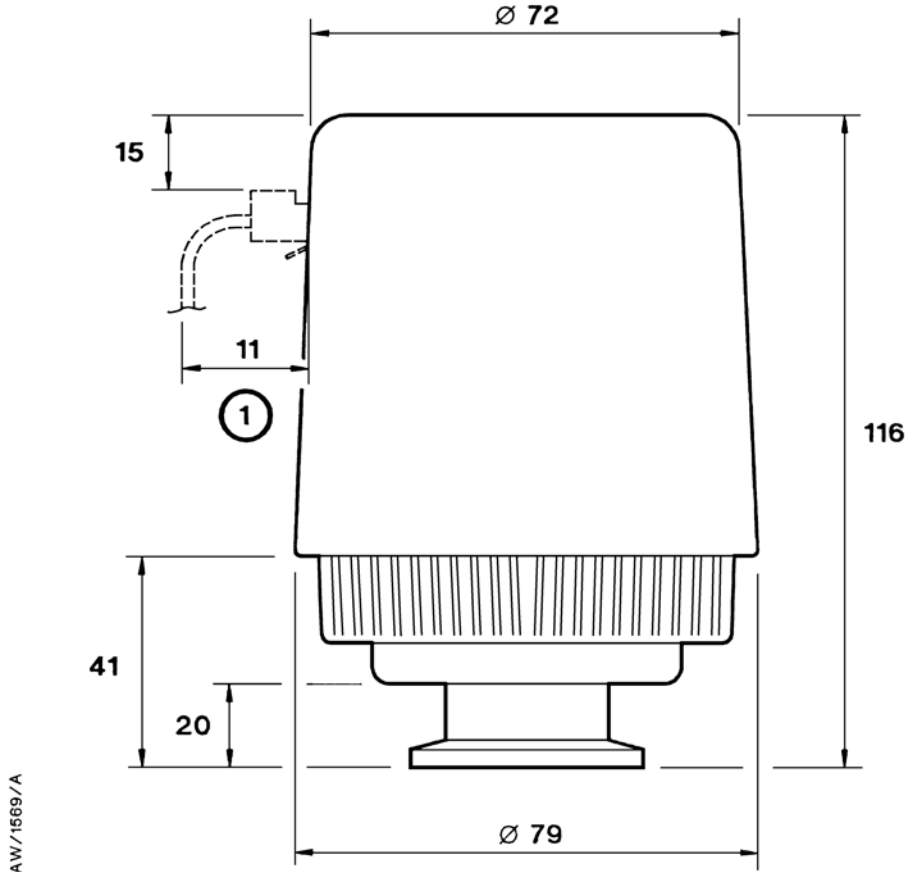

1. Clearance required for electrical cable

3 Installation

3.1 Unpack and inspect



WARNING

The AIM gauge incorporates magnets. Keep away from heart pacemakers, computers, credit cards and any other magnetically sensitive devices.

Remove all packing materials and protective covers and check the AIM Gauge. If the AIM Gauge is damaged, notify your supplier and the carrier in writing within three days; state the Item Number of the AIM Gauge together with your order number and your supplier's invoice number. Retain all packing materials for inspection. Do not use the AIM Gauge if it is damaged.

If the AIM Gauge is not to be used immediately, replace the protective covers.

Store the AIM Gauge in suitable conditions as described in [Section 6](#).

Note: Please consult your supplier in case of any difficulty.

3.2 Fit the AIM gauge to the vacuum system

The AIM Gauge can be mounted in any orientation. To avoid the build up of debris or condensable material in the body tube of the AIM Gauge (which will probably cause pressure measurement errors), we recommend that you install the AIM Gauge vertically as shown in [Figure 2](#).

Use an O-ring/centring ring or co-seal and clamp to connect the NW25 flange of the AIM Gauge to a similar flange on your vacuum system.

If required, you can turn the end cap (relative to the magnet housing) so that the electrical connection socket is in a convenient position on your system; refer to [Figure 1](#) and use the following procedure: hold the magnet housing (4) and turn the end cap (1) in a clockwise or anti-clockwise direction (arrow B) until the electrical connection socket (7) is in the required position.

3.3 Electrical connection



WARNING

If the AIM Gauge malfunctions, the AIM Gauge pressure output may be incorrect. If such a failure could cause injury to people or damage equipment, you must install a suitable control system to indicate the failure and, if necessary, to close down your process system.

When using a cable longer than 30 m, full compliance with European Standards requires an in-line surge suppressor (please refer to [Section 7.3](#)).

Note: Ensure the cable is installed in such a way as to not cause a trip hazard.

3.3.1 Connect to Edwards controllers or AGD display

Connect the AIM Gauge to the controller or display with a cable which is terminated in suitable connectors. Suitable cables are available from Edwards (refer to [Section 7](#)).

3.3.2 Connect to your own supply and control equipment

Note: Do not connect the electrical supply common (pin 2) to the signal common (pin 5). If you do, the AIM Gauge pressure output signal will be inaccurate.

A schematic diagram of the recommended electrical connections to the AIM Gauge is shown in Figure 3.

The pins on the AIM Gauge electrical connection socket are used as shown in Table 1. The specification of the electrical supply, d.c. relay and back EMF suppression diode are given in Section 2.

The connection to pin 6 is optional. Make the connection to pin 6 if you want to connect the set-point output signal to a d.c. relay; you must connect a suppression diode between pins 1 and 6 to protect the AIM Gauge from transient voltages generated when the d.c. relay is switched off.

You can connect a voltmeter between pins 5 and 8 to measure the set-point trip level (that is, the voltage at which the set-point output will go on); see Figure 3.

Connect a switch between pins 2 and 7 to enable and disable the gauge (refer to Section 4.2). If you want to measure the gauge identification signal (which identifies the AIM Gauge), measure the resistance between pins 4 and 5.

Figure 3 - Schematic diagram of typical electrical connections

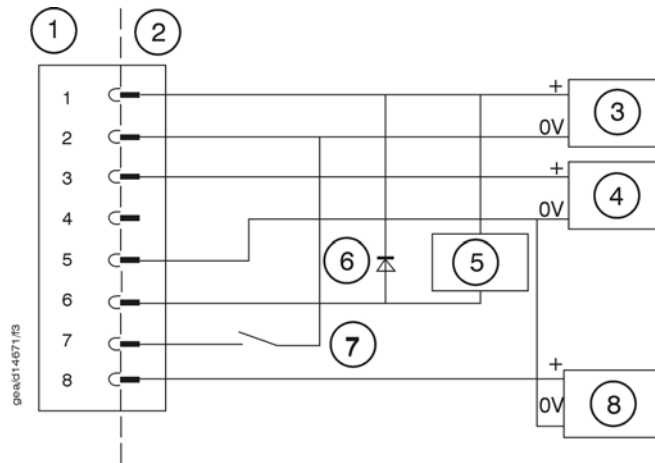

- | | |
|--|--|
| 1. AIM gauge electrical connector socket | 5. D.C. relay (optional) |
| 2. Cable electrical connector plug | 6. Back EMF suppression diode (optional) |
| 3. Electrical supply | 7. Gauge enable switch |
| 4. Voltmeter (pressure signal) | 8. Voltmeter (set-point trip level) |

Table 1 - Pins on the AIM gauge electrical connector socket

| Pin Number | Use |
|------------|------------------------------------|
| 1 | Electrical supply positive voltage |
| 2 | Electrical supply common |
| 3 | Pressure measurement output signal |
| 4 | Gauge identification signal |
| 5 | Signal common |
| 6 | Set-point output signal |
| 7 | Gauge enable |
| 8 | Set-point trip level |

4 Operation

4.1 Safety



WARNING

Do not use the AIM Gauge to measure the pressure of explosive or flammable gases or mixtures.



WARNING

Never operate the AIM Gauge when it is disconnected from the vacuum system or when there are explosive or flammable gases in the surrounding atmosphere of the vacuum system. High voltages (up to 3 kV) are generated inside the body tube of the AIM Gauge; these could cause injury to people or could be a source of ignition.



WARNING

The AIM Gauge incorporates magnets. Keep away from heart pacemakers, computers, credit cards and any other magnetically sensitive devices.

4.2 Enable and disable the AIM gauge

CAUTION

Do not operate the AIM Gauge for long periods when the system pressure is above 1×10^{-2} mbar. If you do the anode pin can be damaged and the AIM Gauge can be severely contaminated.

We recommend that you only enable the AIM Gauge when the system pressure is lower than 1×10^{-2} mbar and that you disable the gauge when the system pressure is 1×10^{-2} mbar or higher.

If you have connected the AIM Gauge to an Edwards Controller, refer to the corresponding instruction manual for details of how to enable (switch on) and disable (switch off) the AIM Gauge.

Otherwise, to enable (switch on) the AIM Gauge, connect pin 7 to pin 2 (or to ground). To disable (switch off) the AIM Gauge, disconnect pin 7 from pin 2 (or from ground).

4.3 Pressure measurement

If you connected the AIM Gauge to an Edwards Controller, the pressure measured by the AIM Gauge is shown on the display.

If you connected the signal output of the AIM Gauge to a voltmeter, convert the measured voltage to the corresponding pressure value: for AIM-SI1 and AIM-SL1, refer to Table 2; for AIM-XI1 and AIM-XLI1 gauges, use the equation $P=10^{(7/8 V - 10.75)}$ where P is the pressure in mbar, and V is the measured voltage.

If necessary, adjust the pressure reading to compensate for the type of residual gas in your vacuum system (refer to Section 1.3).

4.4 Set-point

Note: The set-point is not used if you connect the AIM Gauge to an Edwards Controller.

To adjust the voltage at which the set-point output signal goes on, turn the set-point potentiometer, which is accessible through an access hole in the end cap of the gauge: see [Figure 1](#). Turn the potentiometer clockwise to increase the voltage and turn it anticlockwise to decrease the voltage. Refer to [Section 4.3](#) to determine the operating voltage which corresponds to a given pressure.

The AIM Gauge has an error monitoring facility, which ensures that the set-point output signal is off:

- When the gauge is switched off (that is, not enabled)
- For 0.5 seconds immediately after the AIM Gauge is switched on
- When the pressure output signal is out of range, perhaps because the gauge has failed to strike (ignite)

If required you can adjust the potentiometer so that the set-point operating voltage is < 1.8 V (that is, turn the potentiometer fully anticlockwise). This ensures that the set-point output signal is permanently off.

If required, you can use the set-point output signal to indicate when the Gauge is operating correctly; adjust the potentiometer so that the set-point operating voltage is ≥ 10 V (that is, turn the potentiometer fully clockwise). If the gauge is operating normally, the set-point output signal will then be switched on.

Note: If you adjust the set-point operating voltage to > 9.5 V the hysteresis voltage will be > 10 V and the set-point output signal may not switch off when the pressure rises; if so, the set-point output signal will only go off when the gauge is switched off (that is, disabled).

Table 2 - Pressure and voltage characteristics for nitrogen and dry air

| Pressure (mbar) | Output voltage | Pressure (torr) |
|------------------------|----------------|------------------------|
| 1.0 x 10 ⁻⁸ | 2.00 | 7.5 x 10 ⁻⁹ |
| 2.4 x 10 ⁻⁸ | 2.50 | 1.8 x 10 ⁻⁸ |
| 5.8 x 10 ⁻⁸ | 3.00 | 4.4 x 10 ⁻⁸ |
| 8.1 x 10 ⁻⁸ | 3.20 | 6.1 x 10 ⁻⁸ |
| 1.1 x 10 ⁻⁷ | 3.40 | 8.3 x 10 ⁻⁸ |
| 1.5 x 10 ⁻⁷ | 3.60 | 1.1 x 10 ⁻⁷ |
| 2.1 x 10 ⁻⁷ | 3.80 | 1.6 x 10 ⁻⁷ |
| 2.9 x 10 ⁻⁷ | 4.00 | 2.2 x 10 ⁻⁷ |
| 4.0 x 10 ⁻⁷ | 4.20 | 3.0 x 10 ⁻⁷ |
| 5.4 x 10 ⁻⁷ | 4.40 | 4.1 x 10 ⁻⁷ |
| 7.3 x 10 ⁻⁷ | 4.60 | 5.5 x 10 ⁻⁷ |
| 9.8 x 10 ⁻⁷ | 4.80 | 7.4 x 10 ⁻⁷ |
| 1.3 x 10 ⁻⁶ | 5.00 | 9.8 x 10 ⁻⁷ |
| 1.7 x 10 ⁻⁶ | 5.20 | 1.3 x 10 ⁻⁶ |
| 2.2 x 10 ⁻⁶ | 5.40 | 1.7 x 10 ⁻⁶ |
| 2.8 x 10 ⁻⁶ | 5.60 | 2.1 x 10 ⁻⁶ |
| 3.6 x 10 ⁻⁶ | 5.80 | 2.7 x 10 ⁻⁶ |
| 4.5 x 10 ⁻⁶ | 6.00 | 3.4 x 10 ⁻⁶ |
| 5.6 x 10 ⁻⁶ | 6.20 | 4.2 x 10 ⁻⁶ |
| 6.9 x 10 ⁻⁶ | 6.40 | 5.2 x 10 ⁻⁶ |
| 8.4 x 10 ⁻⁶ | 6.60 | 6.3 x 10 ⁻⁶ |

Table 2 - Pressure and voltage characteristics for nitrogen and dry air (continued)

| Pressure (mbar) | Output voltage | Pressure (torr) |
|----------------------|----------------|----------------------|
| 1.0×10^{-5} | 6.80 | 7.5×10^{-6} |
| 1.2×10^{-5} | 7.00 | 9.0×10^{-6} |
| 1.4×10^{-5} | 7.20 | 1.1×10^{-5} |
| 1.7×10^{-5} | 7.40 | 1.3×10^{-5} |
| 2.0×10^{-5} | 7.60 | 1.5×10^{-5} |
| 2.4×10^{-5} | 7.80 | 1.8×10^{-5} |
| 2.9×10^{-5} | 8.00 | 2.2×10^{-5} |
| 3.5×10^{-5} | 8.20 | 2.6×10^{-5} |
| 4.3×10^{-5} | 8.40 | 3.2×10^{-5} |
| 5.7×10^{-5} | 8.60 | 4.3×10^{-5} |
| 7.9×10^{-5} | 8.80 | 5.9×10^{-5} |
| 1.2×10^{-4} | 9.00 | 9.0×10^{-5} |
| 1.9×10^{-4} | 9.20 | 1.4×10^{-4} |
| 3.3×10^{-4} | 9.40 | 2.5×10^{-4} |
| 6.7×10^{-4} | 9.60 | 5.0×10^{-4} |
| 1.7×10^{-3} | 9.80 | 1.3×10^{-3} |
| 3.6×10^{-3} | 9.90 | 2.7×10^{-3} |
| 1.0×10^{-2} | 10.00 | 7.5×10^{-3} |

5 Maintenance

5.1 Introduction



WARNING

Do not disconnect the electronics and magnet housing from the body tube when the body tube is connected to the vacuum system. If there is a plasma discharge in the vacuum system near the body tube, the body tube can become electrically charged.



WARNING

Disconnect the AIM Gauge before you remove the AIM Gauge from the vacuum system. High voltages are generated inside the AIM Gauge.

The internal components of the AIM Gauge are shown in [Figure 4](#). The AIM Gauge is designed so that you can clean these components, or use the spares listed in [Section 7](#) to replace these components. Refer to the following sections for details of the maintenance procedures which you should do when necessary.

5.2 Replace the body tube

Refer to [Figure 1](#) and use the following procedures to replace the body tube.

5.2.1 Remove the AIM gauge from the vacuum system

1. Switch off the AIM Gauge electrical supply and ensure that the vacuum system is at atmospheric pressure.
2. Disconnect the cable connector plug (5) from the AIM Gauge and remove the AIM Gauge from the vacuum system.

5.2.2 Fit the new body tube

1. Hold the magnet housing (4) and turn the body tube (3) anticlockwise (when viewed from the vacuum flange) to unlock the bayonet fitting. Remove the body tube from the magnet housing.
2. Slide the new body tube into the magnet housing (4).
3. Hold the magnet housing (4) and turn the body tube (3) clockwise (when viewed from the vacuum flange) to lock the bayonet fitting.

5.2.3 Refit the AIM gauge to the vacuum system

Refit the AIM Gauge to the vacuum system as described in [Section 3.2](#) and refit the cable connector plug to the socket on the AIM Gauge (7).

5.3 Replace the electrode assembly

CAUTION

Internal anode assembly includes a sharp-edged component. Care should be taken when handling this item.

Refer to [Figure 4](#) in the following procedure.

1. Remove the AIM Gauge from the vacuum system as described in [Section 5.2.1](#).
2. Remove the body tube from the AIM Gauge as described in [Step 1](#) of [Section 5.2.2](#).
3. Fit the flat spanner supplied in the electrode assembly kit (refer to [Section 7](#)) to the two lugs in the end of the collar (1), then turn the collar anticlockwise to unscrew the collar from the body tube (4) and remove the anode assembly (2) and the O-ring (3).
4. Use circlip pliers to remove the circlip (8) from the vacuum flange end of the body tube, then remove the outer cathode plate (7), cathode tube (6) and the inner cathode plate (5).
5. Fit the new inner cathode plate (5) into the body tube (4) ensuring the end with reduced diameter is furthest from the vacuum flange. Then fit both new cathode tubes (6). If this has been done correctly the second cathode tube will now be protruding about 2 mm beyond the end of the vacuum flange. Hold the outer tube so that the inner cathode plate is held in place, invert the assembly, and rest the outer cathode tube on the bench.
6. Fit the new O-ring (3) and anode assembly (2) into the body tube.
7. Refit the collar (1) to the body tube. Locate the flat spanner on the two lugs on the collar and turn the collar clockwise until it is fully secured in the body tube.
8. Hold the outer tube so that the inner cathode plate is held in place, and re-invert the assembly so that the 14-point striker on the anode can be seen. Remove and discard the outer cathode tube.
9. Now use the 0.5 mm diameter wire supplied to check that the minimum gap between the striker and the inner cathode plate is at least 0.5 mm. This means ensuring the wire is able to pass between the striker and cathode plate all the way round. If not, use a single (gloved) finger on the top of the anode to gently bend it in the appropriate direction. Repeat the test and gentle bending if necessary until the striker-cathode plate gap is 0.5 mm.
10. Fit the new outer cathode plate (7) and secure with the circlip (8). Ensure both the circlip centre and ends are pushed tight towards the inner cathode plate.
11. Refit the tube assembly to the magnet housing as described in [Step 2](#) and [3](#) of [Section 5.2.2](#). Refit the vacuum gauge to the vacuum system as described in [Section 5.2.3](#).

5.4 Replace the electronics and magnet housing

The magnet housing and end-cap contain the AIM Gauge control electronics. Replace the complete unit as described below.

1. Remove the AIM Gauge from the vacuum system.
2. Remove the body tube from the AIM Gauge.
3. Dispose of the old magnet housing and end cap (refer to [Section 6](#)).
4. Fit the body tube to the new magnet housing and end-cap. Refit the AIM Gauge to the vacuum system.

5.5 Clean the internal components

Refer to [Figure 4](#) in the following procedure.

1. Remove the internal components from the magnet housing.
2. Degrease the cathode plate (5), cathode tube (6), body tube (4) and anode assembly (2) in a suitable degreasing agent.
3. Thoroughly soak the components in a suitable laboratory detergent.
4. Rinse the components in clean water to remove the detergent.
5. Rinse the components in alcohol to remove all of the water, then thoroughly dry the components.
6. Inspect the anode assembly and cathode plates to ensure they have no tiny hairs attached.
7. Refit the components in the magnet housing.

Figure 4 - Exploded view of the AIM gauge tube assembly

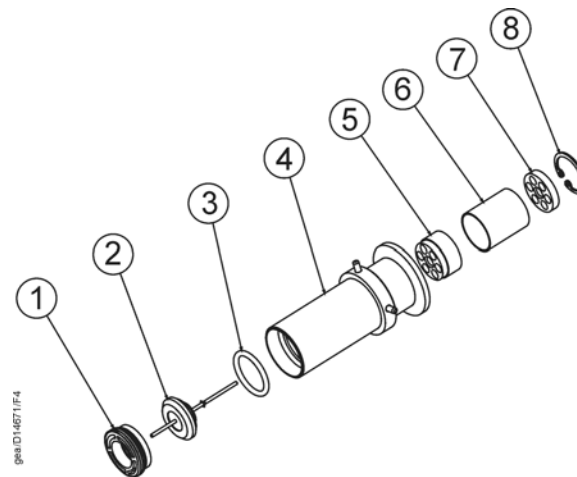

- | | |
|-------------------|------------------------|
| 1. Collar | 5. Inner cathode plate |
| 2. Anode assembly | 6. Cathode tube |
| 3. O-ring | 7. Outer cathode plate |
| 4. Body tube | 8. Circlip |

5.6 Fault finding

If the AIM Gauge does not operate correctly, ensure that the electrical connections are correct (refer to [Section 3](#)) and ensure that your electrical supply is suitable for the AIM Gauge (refer to [Section 2](#)).

6 Storage and disposal

6.1 Storage

Return the AIM Gauge to its protective packaging and store the AIM Gauge in clean dry conditions until required for use. Do not exceed the storage temperature conditions specified in [Section 2](#).

When required for use, prepare and install the AIM Gauge as described in [Section 3](#).

6.2 Disposal

Dispose of the AIM Gauge and any components safely in accordance with all local and national safety and environmental requirements.

Alternatively, you may be able to recycle the AIM Gauge and/or cables; Contact Edwards or your supplier for advice (also see below).

The AIM Gauge and associated cables are within the scope of the European Directive on Waste Electrical and Electronic Equipment. Edwards offers European customers a recycling service for the AIM Gauge/cables at the end of the product's life. Contact Edwards for advice on how to return the AIM Gauge/cables for recycling.

Particular care must be taken if the AIM Gauge has been contaminated with dangerous process substances or if the AIM Gauge has been overheated or has been in a fire.

7 Spares and accessories

7.1 Introduction

Edwards products, spares and accessories are available from Edwards companies in Belgium, Brazil, Canada, France, Germany, Hong Kong, Italy, Japan, Korea, Switzerland, United Kingdom, U.S.A. and a worldwide network of distributors. The majority of these centres employ Service Engineers who have undergone comprehensive training courses.

When you maintain this Edwards product, we recommend you use only Edwards maintenance and service kits.

Order spare parts and accessories from your nearest Edwards company or distributor. When you order, please state for each part required:

- Model and Item Number of your equipment.
- Serial Number (if any).
- Item Number and description of the part.

7.2 Spares

| Spare | Item Number |
|---------------------------------|-------------|
| Electronics and magnet housing: | |
| AIM-S11 | D146-41-800 |
| AIM-X11 | D146-42-800 |
| AIM-SL11 | D146-44-800 |
| AIM-XL11 | D146-45-800 |
| Body tube assembly | D146-71-801 |
| Electrode assembly kit | D146-71-802 |
| Anode assembly kit (10 anodes) | D146-71-810 |

7.3 Accessories

The cables suitable for use with the AIM Gauge are as follows. These cables are supplied with 8-way male electrical connectors on both ends.

| Cable length | Item Number |
|--------------------------------------|-------------|
| 0.5 m 18 inches | D400-01-005 |
| 1.0 m 3 feet | D400-01-010 |
| 3.0 m 10 feet | D400-01-030 |
| 5.0 m 15 feet | D400-01-050 |
| 10 m 30 feet | D400-01-100 |
| 15 m 50 feet | D400-01-150 |
| 25 m 80 feet | D400-01-250 |
| 50 m 150 feet | D400-01-500 |
| 100 m 325 feet | D400-01-999 |
| Surge suppressor | D400-06-000 |

Index

C

| | |
|--|----|
| Clean the internal components | 15 |
| Connect to Edwards controllers or AGD display | 5 |
| Connect to your own supply and control equipment | 6 |

D

| | |
|-----------------------|---|
| Description | 1 |
| Dimensions (mm) | 4 |

E

| | |
|--|----|
| Electrical connection | 5 |
| Electrical data | 3 |
| Enable and disable the AIM gauge | 9 |
| Error monitoring | 4 |
| Exploded view of the AIM gauge tube assembly | 15 |

F

| | |
|--|----|
| Fault finding | 15 |
| Fit the AIM gauge to the vacuum system | 5 |
| Fit the new body tube | 13 |

G

| | |
|-------------------------------------|---|
| Gas dependency | 2 |
| General view of the AIM gauge | 2 |

I

| | |
|--------------------|---|
| Installation | 5 |
|--------------------|---|

M

| | |
|-----------------------------------|----|
| Maintenance | 13 |
| Materials exposed to vacuum | 4 |
| Mechanical data | 3 |

O

| | |
|-----------------|---|
| Operation | 9 |
|-----------------|---|

P

| | |
|---|----|
| Performance, operating and storage conditions | 3 |
| Pins on the AIM gauge electrical connector socket | 7 |
| Pressure and voltage characteristics for nitrogen and dry air | 10 |

R

| | |
|---|----|
| Refit the AIM gauge to the vacuum system | 13 |
| Remove the AIM gauge from the vacuum system | 13 |
| Replace the body tube | 13 |
| Replace the electrode assembly | 14 |
| Replace the electronics and magnet housing | 14 |

S

| | |
|---|----|
| Safety | 9 |
| Schematic diagram of typical electrical connections | 6 |
| Scope and definitions | 1 |
| Set-point | 10 |
| Spares and accessories | 19 |
| Storage and disposal | 17 |

T

| | |
|----------------------|---|
| Technical data | 3 |
|----------------------|---|

U

| | |
|--------------------------|---|
| Unpack and inspect | 5 |
|--------------------------|---|