

Instruction Manual



DP180 Dry Vacuum Pump

Description

DP180 pump, 200 V, 3-phase, 50 Hz
DP180 pump, 200 V, 3-phase, 60 Hz
DP180 pump, 220-240/380-415 V, 3-phase, 50 Hz
DP180 pump, 208-230/380/460 V, 3-phase, 60 Hz

Item Number

A403-02-934
A403-12-934
A403-02-935
A403-12-995

CONTENTS

Section	Title	Page
1	INTRODUCTION	1
1.1	Scope and definitions	1
1.2	The DP180 pump	1
1.3	Gas-ballast boost	2
1.4	Temperature control system	2
1.5	Accessories	2
2	TECHNICAL DATA	3
2.1	General	3
2.2	Performance data	3
2.3	Service	6
2.4	Temperature control system	6
2.5	Lubrication system	6
2.7	Noise data	6
3	INSTALLATION	7
3.1	Safety	7
3.2	Unpack and inspect	7
3.3	Fill the pump with oil	8
3.4	Locate the pump	8
3.5	Electrical installation	10
3.5.1	Select high or low voltage operation	10
3.5.2	Connect the pump-motor electrical supply	12
3.5.3	Check the direction of pump rotation	12
3.5.4	Connect the thermal snap-switch	12
3.5.5	Connect the solenoid-valve	13
3.6	Connect the cooling-water supply	14
3.6.1	Supply quality requirements	14
3.6.2	Connect the supply to the DP180	14
3.7	Connect the DP180 to your vacuum system	16
3.8	Connect the DP180 to your exhaust-extraction system	17
3.9	Gas-ballast boost system	17
3.9.1	Gas-ballast boost not in use	17
3.9.2	Standard air gas-ballast boost	17
3.9.3	Connect the nitrogen supply (if required)	18
3.10	Evacuation of the bearing end-cover (optional)	18
3.11	Leak-test the installation	19
3.12	Commission the installation	19
3.12.1	Adjust the thermostatic control-valve (TCV)	19
3.12.2	Prime the cooling system	20
3.12.3	Commissioning procedure	20

Section	Title	Page
4	OPERATION	21
4.1	21 Start-up	
4.2	Shut-down	21
5	MAINTENANCE	22
5.1	Safety	22
5.2	Maintenance plan	22
5.3	Check the gearbox oil-level	23
5.4	Inspect the pipelines and connections	23
5.5	Change the gearbox oil	24
5.6	Relubricate the rotor bearings	24
5.7	Change the head-plate felt filter	25
5.8	Change the gas-ballast air filter element	26
5.9	Clean the inlet-stage sump	27
5.10	Clean the cooling-jacket	27
6	STORAGE AND DISPOSAL	28
6.1	Storage	28
6.2	Disposal	28
7	SERVICE, SPARES AND ACCESSORIES	29
7.1	Introduction	29
7.2	Service	29
7.3	Spares	29
7.4	Accessories	30

Illustrations

Figure	Title	Page
1	Dimensions (mm)	4
2	Pumping speed curves	5
3	Power curves	5
4	Lubrication and gas-ballast boost components	9
5	Motor low voltage configuration (200 V, 50/60 Hz; 220-240 V, 50 Hz)	11
6	Motor high voltage configuration (380/415 V, 50 Hz; 380 V, 60 Hz)	11
7	Motor low voltage configuration (208-230 V, 60 Hz)	11
8	Motor high voltage configuration (460 V, 60 Hz)	11
9	Thermal snap-switch connections	13
10	Cooling system and bearing end-cover evacuation components	15
11	Rotor bearing re-lubrication	25
12	Exploded view of the gas-ballast air filter	26

Tables

Table	Title	Page
1	Full load current ratings	3
2	Checklist of components	8
3	Pump-motor terminal-box wiring configurations	10
4	Maintenance plan	23

Associated publications

Publication title	Publication Number
Vacuum pump and vacuum system safety	P300-20-000

1 INTRODUCTION

1.1 Scope and definitions

This manual provides installation, operation and maintenance instructions for the BOC Edwards DP180 Dry Vacuum Pump (abbreviated to DP180 in the remainder of this manual). You must use the DP180 as specified in this manual.

Read this manual before you install and operate your DP180. Important safety information is highlighted as WARNING and CAUTION instructions; you must obey these instructions. The use of WARNINGS and CAUTIONS is defined below.

WARNING

Warnings are given where failure to observe the instruction could result in injury or death to people.

CAUTION

Cautions are given where failure to observe the instruction could result in damage to the equipment, associated equipment or process.

The units used throughout this manual conform to the SI international system of units of measurement.

1.2 The DP180 pump

The DP180 dry pump operates at pressures between atmospheric and ultimate vacuum without any lubricating or sealing fluid in the pumping chamber. This ensures a clean pumping system without back-migration of oil into the system being evacuated. The pump is mounted on steel runners.

The DP180 is a three-stage, positive-displacement rotary pump in which pairs of intermeshing rotors (of different profiles mounted on common shafts) are held in correct phase relation by a pair of timing-gears. The timing-gears and the adjacent double-row angular contact ball-bearings are oil lubricated.

The pump casing material is cast-iron, the shafts and rotors are made from SG iron. The internal and external shaft-seals on the pump shafts and the motor drive-shaft are made from polytetrafluoroethylene (PTFE).

Bearings are located on the high vacuum end of the shaft, near to the pump-inlet. These bearings are packed with perfluoropolyether (PFPE) grease. As supplied, the bearing end-cover is connected internally to the pump-inlet and is evacuated when the DP180 pump is operating. If required, you can use your own external evacuation pump to evacuate the bearing end-cover.

1.3 Gas-ballast boost

The DP180 has a gas-ballast boost system which delivers air to the pump gas-ballast boost inlet. The flow of air is filtered and is controlled by a solenoid-valve. You can connect the solenoid-valve to your control equipment to operate the solenoid-valve.

If you wish, you can connect a nitrogen supply to the system in order to deliver nitrogen to the pump instead of air.

1.4 Temperature control system

The pump is cooled by water which flows through an integral cooling-jacket. The pump is maintained at a constant operating temperature by a thermostatic control-valve (TCV) which controls the supply of cooling-water to the pump.

The pump-motor is air-cooled by a cooling-fan which is integral to the motor.

A thermal snap-switch is fitted to the pump-body. This switch shuts down the pump if the pump is too hot. The switch (which is normally-closed) is connected to the overload control loop of the pump-motor starter. When the temperature of the pump-body rises to 71 °C, the switch opens and the pump-motor is switched off.

1.5 Accessories

If the DP180 pump is to be used on clean applications, the pump-outlet can be fitted with a stainless steel flap-valve accessory. On dirty applications, if the use of an outlet-valve is necessary, we recommend that you fit a fluoroelastomer flap-valve accessory.

A full list of the accessories available for the DP180 pump is given in Section 7.

2 TECHNICAL DATA

2.1 General

Overall dimensions	See Figure 1
Mass	230 kg
Nominal motor rating	7.5 kW
Rotational speed	2000 r min ⁻¹
Warm-up time	15 min
Vacuum connections	
Inlet	ISO63
Outlet	NW40
Vacuum system maximum leak-rate	1 x 10 ⁻³ mbar l s ⁻¹ , 1 x 10 ⁻¹ Pa l s ⁻¹
Ambient operating temperature range	5 to 40 °C
Maximum ambient operating humidity	90% RH
Maximum exhaust pressure	2 psig, 1150 mbar absolute, 1.15 x 10 ⁵ Pa

2.2 Performance data

Pumping speed range	See Figure 2
Power curves	See Figure 3
Peak pumping speed	180 m ³ h ⁻¹
Displacement (swept volume)	200 m ³ h ⁻¹
Ultimate vacuum (without outlet flap-valve)	
without gas-ballast boost	1 x 10 ⁻¹ mbar, 10 Pa
with full gas-ballast boost	2.5 x 10 ⁻¹ mbar, 25 Pa
Water vapour pumping speed at 80 mbar (8 x 10 ³ Pa)	5 kg h ⁻¹
Full load current ratings	See Table 1

Electrical supply		Rating (kW)	Full load (A)
Voltage (V)	Frequency (Hz)		
200	50/60	7.5	31.0
208	60	7.0	25.2
220-240	50	7.5	26.8
380-415	50	7.5	15.5
230	60	8.5	25.4
380	60	7.5	19.5
460	60	8.5	14.2

Table 1 - Full load current ratings

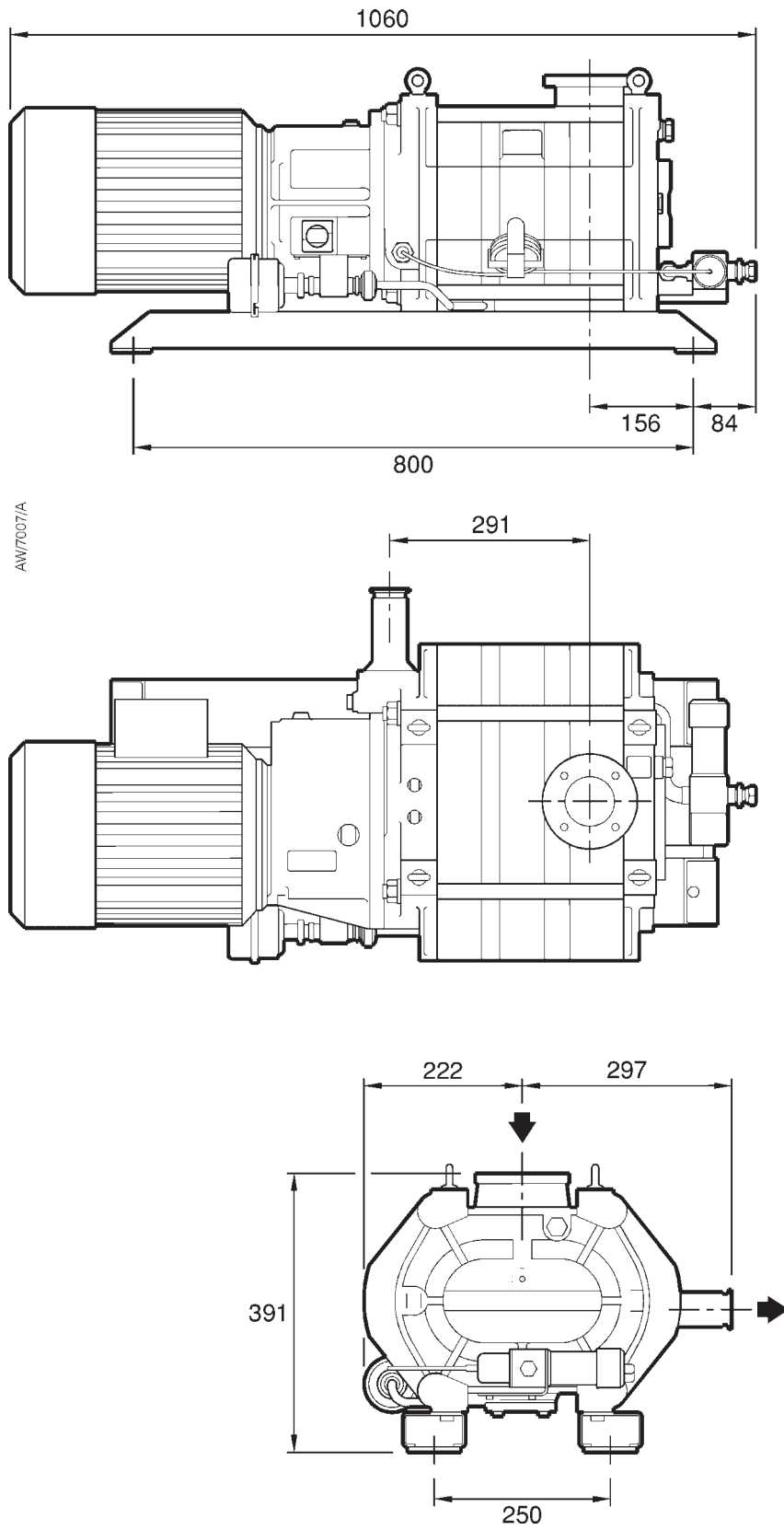
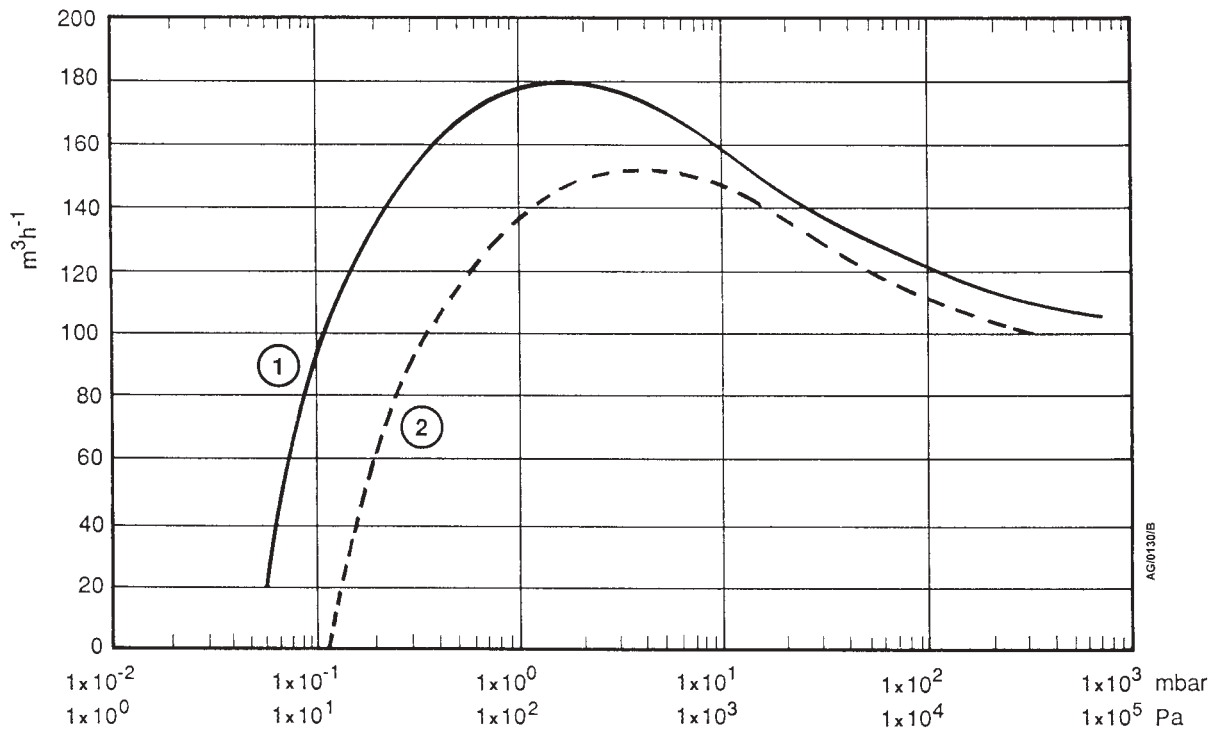
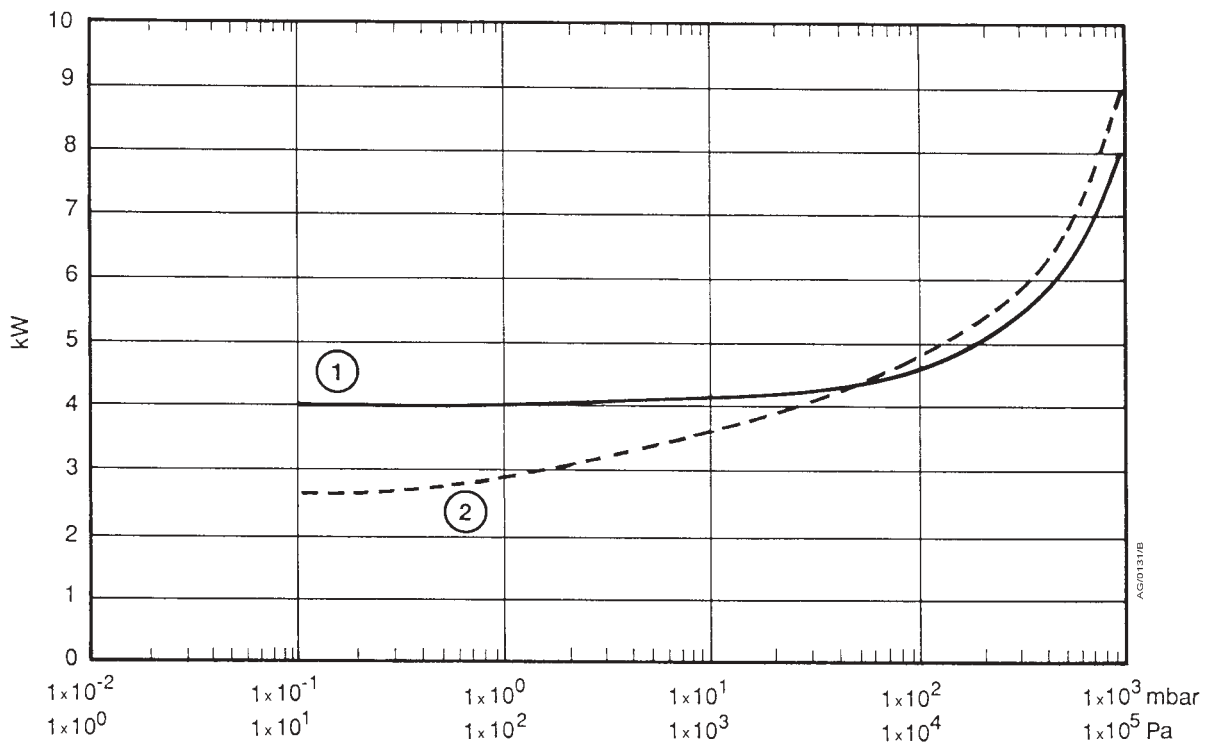

Figure 1 - Dimensions (mm)



1. With stainless steel flap-valve
2. Without flap-valve

Figure 2- Pumping speed curves



1. Without flap-valve
2. With stainless steel flap-valve

Figure 3- Power curves

2.3 Services

Electrical supply	
Number of phases	3
Supply voltage	200/220-240/380-415 V at 50 Hz, 200/208-230/380/460 V at 60 Hz
Voltage tolerance	±6% except for 200 V at 50/60 Hz and 380 V at 60 Hz which are ±10%
Cooling-water supply	
Ryznar Stability Index (RSI)	6.5 to 7.0
Water consumption at 20 °C (TCV setting: 3 to 3.5)	100 l h ⁻¹
Maximum supply pressure	100 psi
Minimum required pressure differential across supply and return	30 psi
Nitrogen supply (if fitted)	
Supply pressure	5 to 10 psig
Maximum flow rate	100 l min ⁻¹

2.4 Temperature control system

Thermostatic control-valve	
Type	Danfoss AVTA
Maximum operating temperature	130 °C
Maximum sensor temperature	90 °C
Thermal snap-switch	
Manufacturer	Microtherm
Opening temperature	71 ± 3 °C
Contact rating	
Maximum voltage/current	240 V/2.9 A

2.5 Lubrication system

Note: BOC Edwards Material Safety Data Sheets for the oils and greases referenced below are available on request.

Gearbox	
Fluid capacity (timing gearbox)	1.2 litres
Grade of oil	SAE 40
ISO viscosity grade	150
Recommended perfluoropolyether oils	Fomblin Y25 or Krytox 1525
High vacuum bearings	
Grease type	Perfluoropolyether
Recommended grease	Fomblin RT15, Krytox 240AD

2.6 Noise data

If the DP180 is not fitted inside an acoustic enclosure, under certain pumping conditions the continuous A-weighted sound pressure level can reach 90 dB(A).

3 INSTALLATION

3.1 Safety

WARNING

Obey the safety instructions given below and take note of appropriate precautions. If you do not, you can cause injury to people and damage to equipment.

- A suitably trained and supervised technician must install the DP180.
- Ensure that the installation technician is familiar with the safety precautions which relate to the products pumped. Wear the appropriate safety-clothing when you come into contact with contaminated components. Dismantle and clean contaminated components inside a fume-cupboard.
- If the DP180 is to replace an existing pump, vent and purge the pumping system before you start any installation work.
- Disconnect the other components in the pumping system from the electrical supply so that they cannot be operated accidentally.
- Do not re-use 'O' rings and Co-Seals and do not allow debris to get into the DP180 during installation.
- Before you use the DP180 to pump dangerous substances, refer to the associated publication referred to at the end of the contents list. You must take all necessary precautions to dilute flammable gases with nitrogen to a safe level.
- Leak-test the system after installation and seal any leaks found.

3.2 Unpack and inspect

WARNING

Use suitable lifting equipment to move the DP180. Refer to Section 2 for the mass of the pump.

Use the following procedure to unpack and inspect the pump:

1. Use a fork-lift truck or a pallet truck to move the DP180 on the pallet into a convenient position .
2. Open the cardboard box and remove the packing material from around the pump.
3. Use suitable lifting-gear attached to the lifting-eyes provided to remove the pump from its pallet.

4. Inspect the pump. If the pump or any other item is damaged, notify your supplier and the carrier in writing within three days; state the Item Number of the pump together with your order number and your suppliers invoice number. Retain all packing materials for inspection. Do not use the pump if it is damaged.
5. Check that the pallet contains the items listed in Table 2. If any of these items is missing, notify your supplier in writing within three days.
6. If the pump is not to be used immediately, replace the packing materials and store the pump in suitable conditions as described in Section 6.

Qty	Description	Check (✓)
1	DP180 pump	<input type="checkbox"/>
1	General fitting-kit	<input type="checkbox"/>

Table 2 - Checklist of components

3.3 Fill the pump with oil

Use the following procedure to fill the pump with oil.

1. Refer to Figure 4. Ensure that the oil drain-plug (5) is tight.
2. Unscrew and remove the oil filler-plug (2).
3. Fill the gearbox with oil until the oil-level is at the MAX level mark on the oil-level sight-glass (4).
4. Check that the rubber bonded seal on the oil filler-plug is in place, then refit the oil filler-plug (2) and tighten to finger tight. Use a spanner to tighten the plug an additional $\frac{1}{16}$ th of a turn.

3.4 Locate the pump

WARNING

Use suitable lifting equipment to move the DP180. Refer to Section 2 for the mass of the pump.

Use the following procedure to locate the DP180; the DP180 must be located on a firm, level surface.

1. Use suitable lifting-gear attached to the lifting bolts (see Figure 1) to locate the DP180 in its final operating position.
2. If required, fit four bolts through the 12 mm fixing-holes in the runners to secure the DP180 in place. If you do not fit bolts and leave the pump free-standing, we recommend that you fit vibration isolators; these are available as optional accessories (see Section 7).

AW/7008/A

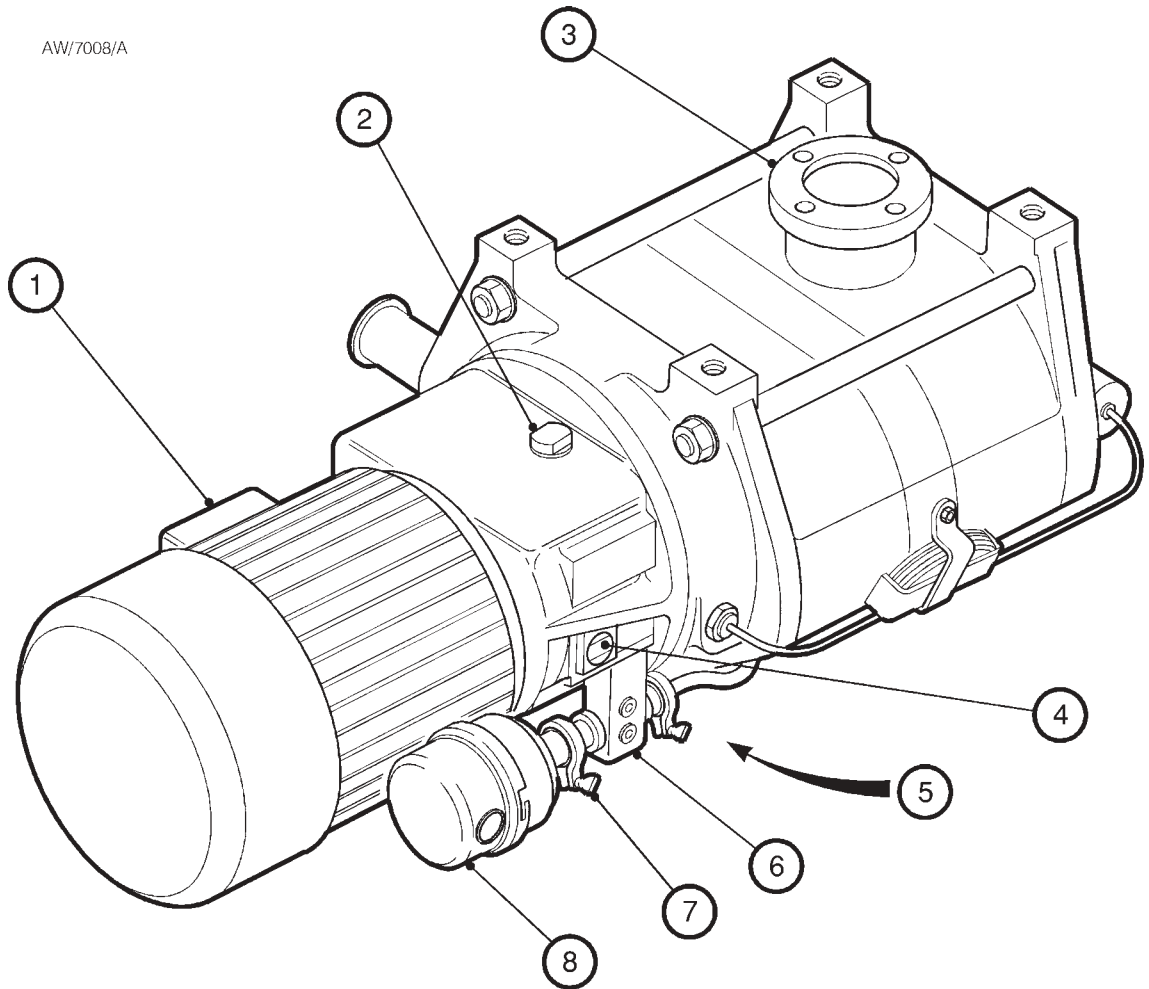

- | | |
|----------------------------|---------------------------|
| 1. Pump-motor terminal-box | 5. Oil drain-plug |
| 2. Oil filler-plug | 6. Solenoid-valve |
| 3. Inlet-flange | 7. Clamping-ring |
| 4. Oil-level sight-glass | 8. Gas-ballast air filter |

Figure 4 - Lubrication and gas-ballast boost components

3.5 Electrical installation

WARNING

Ensure that the electrical installation of the DP180 conforms with your local and national safety requirements. It must be connected to a suitably fused and protected electrical supply and a suitable earth (ground) point.

3.5.1 Select high or low voltage operation

The universal voltage and frequency motor can be configured for low voltage operation (200/220-240 V at 50 Hz or 208-230 V at 60 Hz) or for high voltage operation (415 V at 50 Hz, 380 V at 50/60 Hz, or 460 V at 60 Hz).

Figures 5 to 8 show the required wiring configurations for the electrical supply voltages and frequencies as shown in Table 3.

Electrical supply		Refer to Figure
Voltage (V)	Frequency (Hz)	
200	50	5
200	60	5
220-240	50	5
380/415	50	6
208-230	60	7
380	60	6
460	60	8

Table 3 - Pump-motor terminal-box wiring configurations

Use the following procedure to configure the pump for use with your electrical supply:

1. Check the information on the pump-motor data plate to make sure that the pump is suitable for use with your electrical supply voltage and frequency. If the pump is not suitable, do not continue to install it.
2. Remove the cover from the pump-motor terminal-box.
3. Check the configuration of the links in the motor terminal-box. If necessary, change the configuration to suit your electrical supply voltage and frequency (see Figures 5 to 8).

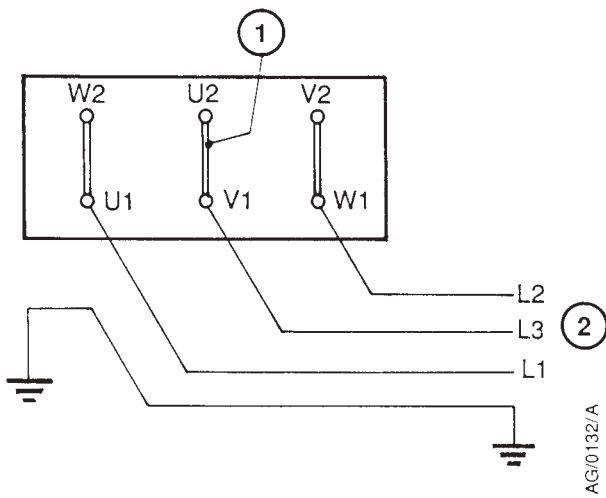

1. Links
2. Electrical supply

Figure 5 - Motor low voltage configuration
(200 V, 50/60 Hz; 220-240 V, 50 Hz)

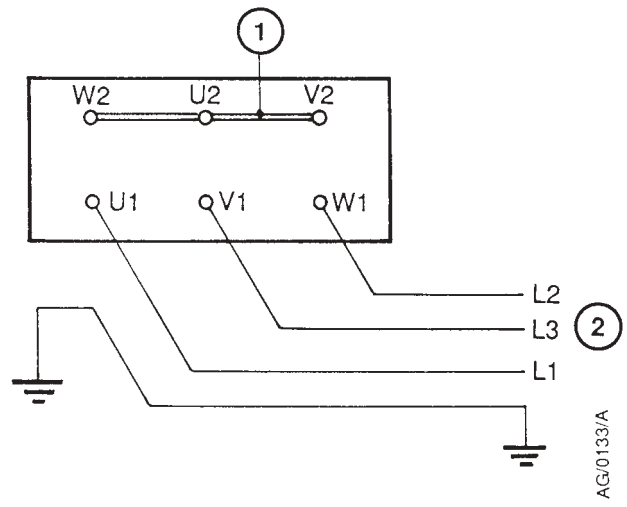

1. Links
2. Electrical supply

Figure 6 - Motor high voltage configuration
(380/415 V, 50 Hz; 380 V, 60 Hz)

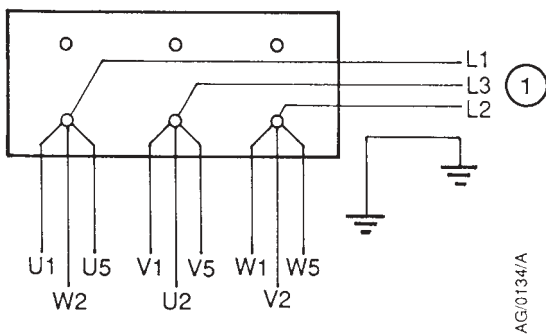

1. Electrical supply

Figure 7 - Motor low voltage configuration
(208-230 V, 60 Hz)

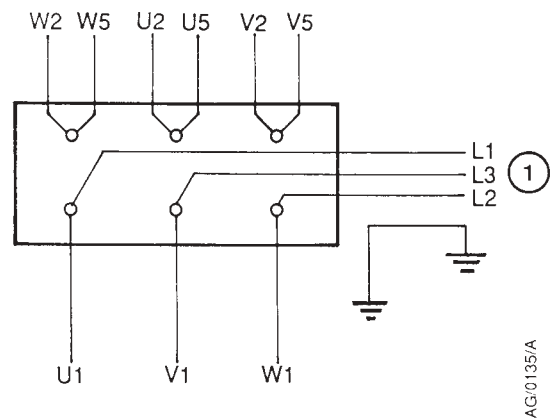

1. Electrical supply

Figure 8 - Motor high voltage configuration
(460 V, 60 Hz)

3.5.2 Connect the pump-motor electrical supply

Notes: Wiring instructions for the pump-motor are also shown on a label inside the terminal-box cover.

*The following procedure will ensure that the pump will rotate in the correct direction if phase 1 of your electrical supply corresponds to line L1 in Figures 5 to 8, phase 2 corresponds to line L2 and phase 3 corresponds to line L3. However, we recommend that you check the direction of rotation of the pump as described in Section 3.5.3. You **must** use the procedure in Section 3.5.3 to check the direction of rotation if you do not know the phase order of your electrical supply.*

Use the following procedure to connect the electrical supply to the pump motor. Connect your electrical supply to the pump-motor through a suitable contactor which has an overload protection facility. Use appropriately rated 4-core cable and a suitable cable-gland.

1. Connect the phase-wires of your electrical supply cable to the appropriate terminals inside the terminal-box (refer to Section 3.5.1 and to Figures 5 to 8).
2. Connect the earth (ground) wire to the earth (ground) terminal inside the terminal-box.
3. Refit the cover to the pump-motor terminal-box.

3.5.3 Check the direction of pump rotation

1. Look at the pump-motor cooling-fan, switch on the DP180 for one or two seconds, then switch the DP180 off again.
2. If the fan rotated anticlockwise when viewed from the motor end of the pump, the direction of rotation is incorrect. If the direction of rotation is incorrect:
 - Isolate the DP180 from the electrical supply.
 - Remove the cover from the pump-motor terminal-box, reverse any two of the phase-wires in the terminal-box, then refit the cover to the terminal-box.
 - Repeat the check from Step 1 to ensure that the direction of rotation is correct.

3.5.4 Connect the thermal snap-switch

The thermal snap-switch is fitted to the pump cooling-water jacket and is connected to the 2-way terminal-block in the motor terminal-box.

You must use a suitable cable to connect the 2-way terminal-block to the motor-starter overload-control loop, as shown in Figure 9.

You must connect the thermal snap-switch to the motor-starter overload-control loop so that, if the DP180 overheats and the switch operates (that is, the switch contacts open), it will trip the contactor and the DP180 will be switched off. When the pump cools and the switch contacts close again, the DP180 will not then automatically restart; you must manually reset the contactor before you can start the DP180 again.

3.5.5 Connect the solenoid-valve

Connect the gas-ballast boost solenoid-valve (Figure 4, item 6) to your control equipment so that the valve closes when the DP180 is shut down. Use a suitably rated fused electrical supply (refer to Section 2).

If the solenoid-valve is left open after the DP180 is shutdown, the pressure in your vacuum system could rise to the pressure of your nitrogen supply; see Section 3.9.3.

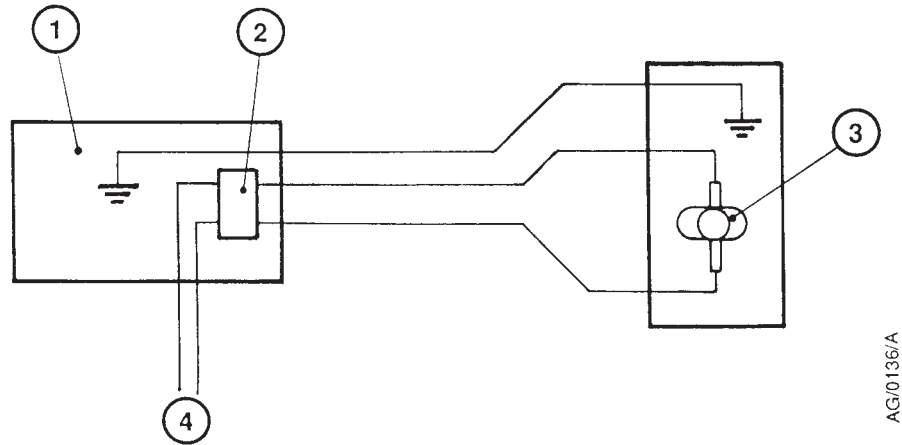

1. Pump-motor terminal-box
2. 2-way terminal-block
3. Thermal snap-switch
4. To the motor starter overload-control loop

Figure 9 - Thermal snap-switch connections

3.6 Connect the cooling-water supply

CAUTION

If your pump is installed in an area where the ambient temperature falls close to or below freezing point, ensure that the cooling-water cannot freeze inside the pump cooling-jacket or TCV. If the cooling-water freezes, the pump or TCV can be damaged.

3.6.1 Supply quality requirements

Your cooling-water must meet the requirements of Section 2.3. If it does not, you may get a build-up of deposits inside the pump cooling-jacket. If you have any doubt about the quality of your supply, contact your local water authority who can tell you its RSI and advise on treatments which you can carry out to make your supply suitable for use with the DP180.

If you use a treated closed-circuit cooling system, we recommend that you fill it (and refill it) with de-ionised or reverse-osmosis treated water.

3.6.2 Connect the supply to the DP180

CAUTION

Make sure you connect the cooling-water supply and return hoses to the correct connectors on the DP180. If the hoses are incorrectly fitted, the DP180 may overheat and may be damaged.

The cooling-water connections on the DP180 are suitable for use with hoses with an outside diameter of 12 mm ($1/2$ inch). If you need to connect more than one DP180 to the cooling-water supply, you must connect the pumps in parallel and not in series.

1. Connect the cooling-water supply hose to the cooling-water inlet (Figure 10, item 6).
2. Connect the return hose to the pump cooling-water outlet (Figure 10, item 2).

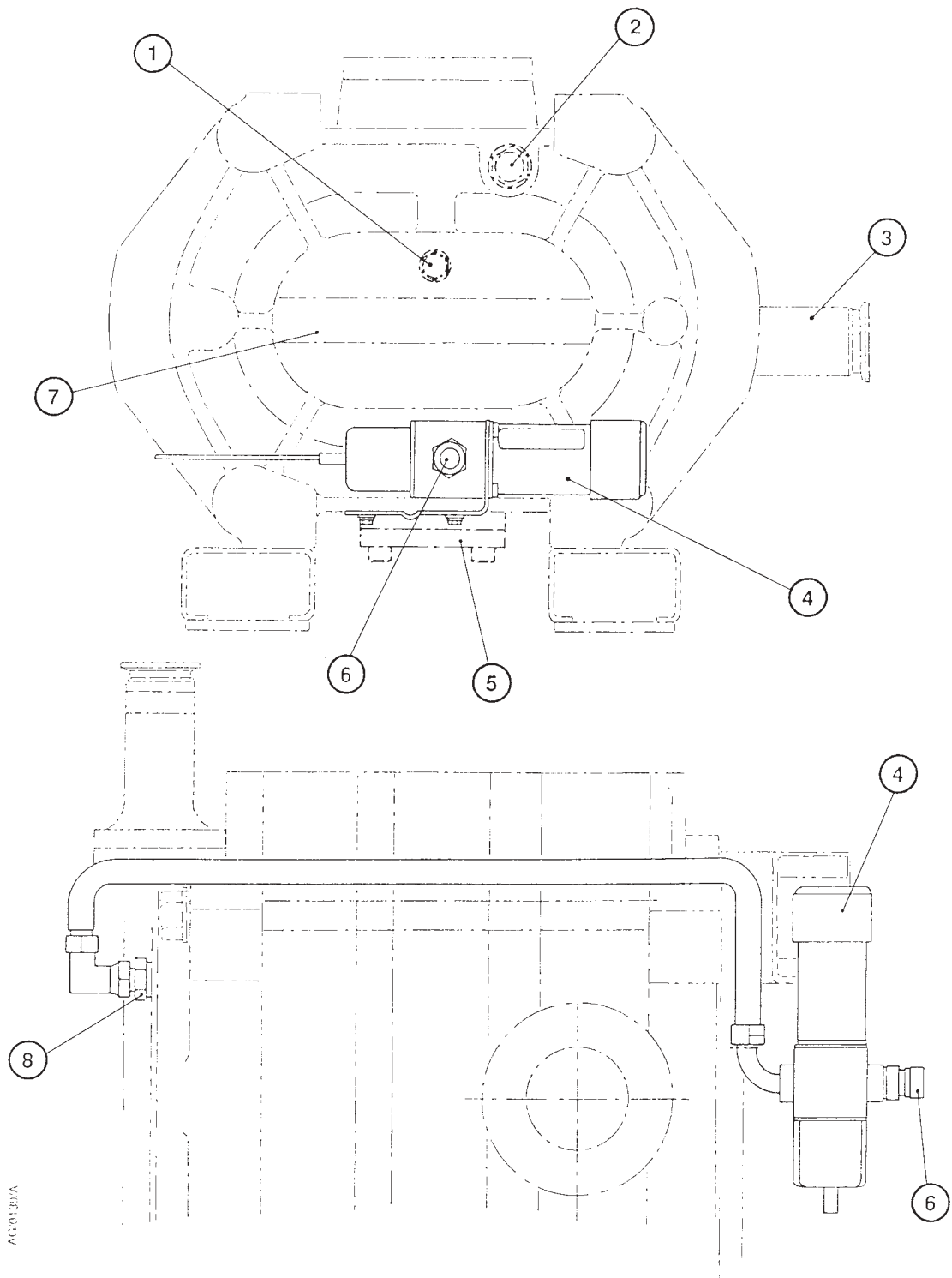

- | | |
|--------------------------------------|----------------------------------|
| 1. Bearing end-cover evacuation plug | 5. Inlet-stage sump clamp-plate |
| 2. Cooling-water outlet | 6. Cooling-water inlet |
| 3. Exhaust outlet | 7. Bearing end-cover |
| 4. Thermostatic control-valve | 8. Pump body cooling-water inlet |

Figure 10 - Cooling system and bearing end-cover evacuation components

3.7 Connect the DP180 to your vacuum system

WARNING

Do not operate the DP180 with the exhaust-pipeline blocked. If the exhaust-pipeline is blocked, the DP180 can generate exhaust-pipeline pressures up to 7 bar.

When you connect the DP180 to your vacuum system, take note of the following:

- To get the best pumping speed, ensure that the pipeline which connects the vacuum system to the DP180 inlet is as short as possible and has an internal diameter not less than that of the DP180 inlet port.
- Incorporate a flexible connection in the pipeline to reduce vibration and stress in the system pipelines.
- On very dusty applications, use an inlet-filter to minimise damage to the DP180.
- You must be able to isolate the pump-inlet from the atmosphere and from your vacuum system if you have pumped or produced corrosive chemicals.
- Adequately support vacuum pipelines to stop the transmission of stress to the coupling-joints.

Use the following procedure to connect the DP180 inlet-flange to your vacuum system.

1. Remove the four cap-head bolts, nuts and washers, then remove the blanking-plate from the pump-inlet.
2. Retain the nuts, bolts and washers for future use.
3. Use the Co-Seal supplied in the fitting-kit to connect the pump inlet-flange to your vacuum system. Use the bolts provided in the general fitting-kit or the bolts removed in Step 1 to secure the connection.

3.8 Connect the DP180 to your exhaust-extraction system

WARNING

Pipe the exhaust to a suitable treatment plant to prevent the discharge of dangerous gases or vapours to the surrounding atmosphere.

WARNING

Use a catchpot to prevent the drainage of condensate back into the DP180. Condensate which drains back into the DP180 could damage it.

When you connect the DP180 to your exhaust-extraction system, take note of the following:

- Incorporate flexible pipelines in the exhaust pipeline to reduce the transmission of vibration and to prevent loading of the coupling-joints. If you use flexible pipelines, you must use flexible pipelines which have a maximum pressure rating which is greater than the highest pressure that can be generated in your system. We recommend that you use BOC Edwards braided flexible pipelines.
- You must be able to isolate the pump exhaust from the atmosphere if you have pumped or produced corrosive chemicals.
- You must adequately support exhaust pipelines to prevent the transmission of stress to the coupling-joints.

Use NW40 fittings to connect the outlet-flange of the DP180 to your exhaust-extraction system.

3.9 Gas-ballast boost system

3.9.1 Gas-ballast boost not in use

When the gas-ballast boost is not in use (that is, the solenoid-valve is closed), some process gas may leak in the reverse direction to atmosphere.

We therefore recommend that you either remove the air-filter and fit an NW10 blanking-plate or use a positive-pressure nitrogen supply when you pump toxic, pyrophoric or flammable gases, in order to prevent the leakage of gases into the atmosphere.

3.9.2 Standard air gas-ballast boost

As supplied, the DP180 has a gas-ballast boost system which delivers air to the gas-ballast boost inlet of the pump. To use this system, connect the solenoid-valve to the electrical supply as described in Section 3.5.5.

The gas-ballast boost pipe has a non-return valve, however some of the process gas pumped can leak through the valve if you are rough pumping (above an inlet pressure of 650 mbar, 6.5×10^4 Pa).

If you will pump dangerous substances, we therefore recommend that you use a bottled nitrogen supply or a closed system; refer to Section 3.9.3 to connect the nitrogen supply.

3.9.3 Connect the nitrogen supply (if required)

WARNING

When you connect a nitrogen supply to the gas-ballast boost pipeline, install a suitable pressure relief system if your vacuum system is not suitable for pressures above atmospheric pressure. If you do not, the pressure in your system could rise to the pressure of the nitrogen supply.

When necessary, you can connect a nitrogen supply to the gas-ballast boost system so that nitrogen is delivered to the DP180 instead of air.

Use the following procedure to connect your nitrogen supply.

1. Refer to Figure 3. Undo and remove the NW10 clamp (7) which secures the air-filter (8) to the gas-ballast boost pipe. Remove the air-filter.
2. Connect your nitrogen supply to the gas-ballast boost pipe through an NW10 adaptor. Your nitrogen supply must meet the specification given in Section 2.
3. Fit the NW10 clamp (removed in Step 1) to secure the adaptor.

3.10 Evacuation of the bearing end-cover (optional)

If you want to use an external evacuation pump to evacuate the bearing end-cover, use the following procedure to connect the pump:

1. Remove the six fixing-screws which secure the bearing end-cover to the high vacuum head-plate (see Figure 10).
2. Lift away the end-cover and carefully remove the sealing 'O' ring.
3. Use a suitable tool to prise the felt filter out from the head-plate.
4. Apply a light wipe of sealing compound to a $1/4$ inch BSP tapered plug and fit the plug to the head-plate.
5. Check the condition of the 'O' ring removed in Step 2. If the 'O' ring is damaged, replace it with a new 'O' ring.
6. Apply a light wipe of PFPE grease to the 'O' ring and place it in its groove on the head-plate. Refit the bearing end-cover to the head-plate.
7. Remove the $3/8$ inch BSP taper-plug from the bearing end-cover.

8. Use $3/8$ inch BSP fittings to connect a suitable pipeline to the end-cover. Connect the other end of the pipeline to your evacuation pump.

3.11 Leak-test the installation

WARNING

Leak-test the system after installation and seal any leaks found to prevent the leakage of dangerous substances from the system and leakage of air into the system.

Leak-test the system after installation and seal any leaks found. Dangerous substances which leak from the system will be dangerous to people and there may be a danger of explosion if air leaks into the system. We recommend that the leak rate is 1×10^{-3} mbar $l s^{-1}$ (1×10^{-1} Pa $l s^{-1}$) helium or less.

3.12 Commission the installation

3.12.1 Adjust the thermostatic control-valve (TCV)

CAUTION

Do not adjust the TCV to a lower setting (that is, towards 0) when the DP180 is hot. This will increase the flow of cooling-water which may damage the DP180 because of the differential contraction of the pump rotor and case.

The TCV regulates the flow of water through the pump cooling-jacket to maintain the DP180 at the required operating temperature. The TCV can be adjusted between 0 (minimum) and 5 (maximum). Adjustment of the TCV varies the operating temperature of the DP180.

You must adjust the TCV to suit your operating conditions. Use a high TCV setting when you pump condensable vapours to prevent condensation in the pump.

We recommend that you do not exceed a maximum DP180 operating temperature of $65^{\circ}C$ in normal use (that is, a TCV setting of 3 to 3.5). If you set the TCV at a higher temperature, the thermal snap-switch will operate to shut down the DP180.

3.12.2 Prime the cooling system

1. Isolate the DP180 from your vacuum system.
2. Turn the TCV to the '0' setting and turn on the cooling-water supply.
3. Allow the cooling-water to flow for five to six minutes to ensure that the cooling-jacket is full of water.
4. Check all of the water connections and pipelines for leaks. Seal any leaks found.
5. Turn the TCV to the required setting.

3.12.3 Commissioning procedure

1. Turn on the electrical supply, the nitrogen supply and your exhaust-extraction system (if fitted).
2. Check all of the nitrogen system, exhaust-extraction system and vacuum system connections.
3. Switch on the DP180.
4. Wait for approximately 15 minutes to allow the pump operating temperature to stabilise, then check that the TCV operates correctly (that is, that the DP180 is at the correct operating temperature).
5. Turn off the electrical supply to the DP180 and the services.

4 OPERATION

WARNING

Take all appropriate safety precautions when you pump oxidants or pyrophoric or flammable gases.

4.1 Start-up

Use the following procedure below to start up the pump.

1. Check the gearbox oil-level in the sight-glass on the side of the pump (Figure 4, item 4). The oil-level must be between the MIN and MAX marks when the pump is cold and at rest. If necessary, pour more oil into the pump (refer to Section 3.3) or drain oil from the pump (refer to Section 5.5).
2. Switch on the electrical supply, the cooling-water supply, the nitrogen supply and the exhaust-extraction system (if fitted).
3. Check all of the water, nitrogen system, exhaust-extraction system (if any) and vacuum system connections.
4. Switch on the DP180.
5. If required, use your control equipment to open the gas-ballast boost solenoid-valve. Set your nitrogen supply pressure and flows to suit your process conditions.

4.2 Shut-down

Use the following procedure to shut down the DP180.

1. Isolate the pump-inlet from your vacuum system and operate the DP180 for 15 minutes with the gas-ballast boost solenoid-valve open.
2. Close the gas-ballast boost solenoid-valve and switch off your nitrogen supply (if fitted).
3. Switch off the DP180.
4. Turn off the cooling-water supply and your exhaust-extraction system (if fitted).

5 MAINTENANCE

5.1 Safety

WARNING

Obey the safety instructions given below and take note of appropriate precautions. If you do not, you can cause injury to people and damage to equipment.

- A suitably trained and supervised technician must maintain the DP180.
- Ensure that the maintenance technician is familiar with the safety procedures which relate to the products pumped. Wear the appropriate safety-clothing when you come into contact with contaminated components. Dismantle and clean contaminated components inside a fume-cupboard.
- Allow the DP180 to cool to a safe temperature before you start maintenance work.
- Vent and purge the pumping system with nitrogen before you start any maintenance work.
- Isolate the DP180 and other components in the pumping system from the electrical supply so that they can not be operated accidentally.
- Recheck the direction of pump rotation if the electrical supply has been disconnected.
- Do not reuse 'O' rings and Co-Seals.
- Dispose of components, grease and oil safely (see Section 6.2).
- Take care to protect sealing-faces from damage.
- Do not touch or inhale the thermal breakdown products of fluorinated materials which may be present if the DP180 has been overheated to 260 °C and above. These breakdown products are very dangerous. Fluorinated materials in the DP180 may include oils, greases and seals. The DP180 may have overheated if it was misused, if it malfunctioned, or if it was in a fire. BOC Edwards Materials Safety Data Sheets for fluorinated materials used in the DP180 are available on request: contact your supplier or BOC Edwards.
- Leak-test the system after maintenance is complete if you have disconnected any vacuum or exhaust joints and seal any leaks found (refer to Section 3.11).

5.2 Maintenance plan

The plan shown in Table 4 details the maintenance operations necessary to maintain the DP180 in normal operation. Instructions for each operation are given in the section shown.

More frequent maintenance may be required if the DP180 is used to process corrosive or abrasive gases and vapours. If necessary, adjust the maintenance plan according to your experience.

When you maintain the DP180, use BOC Edwards service kits. These kits contain all of the necessary components to complete maintenance operations. The Item Numbers of the service kits are given in Section 7.3.

Operation	Frequency	Refer to Section
Check the gearbox oil-level	Monthly	5.3
Inspect the pipelines and connections	6 Monthly	5.4
Change the gearbox oil	6 Monthly	5.5
Relubricate the rotor bearings	6 Monthly	5.6
Change the head-plate felt filter	Yearly	5.7
Change the gas-ballast air filter element	Yearly	5.8
Clean the inlet-stage sump	As required	5.9
Clean the cooling-jacket	As required	5.10

Table 4 - Maintenance plan

5.3 Check the gearbox oil-level

Refer to Figure 4. Check the pump gearbox oil-level on the sight-glass (4). The level of oil must be between the MIN and MAX marks when the pump is off and is cold:

- If the oil-level is below the MIN mark, pour more oil into the DP180 until the oil-level is correct: refer to Section 3.3.
- If the oil-level is above the MAX mark, drain oil from the gearbox until the oil-level is correct: refer to Section 5.5.

5.4 Inspect the pipelines and connections

1. Inspect all of the cooling-water connections and check that they are secure; tighten any loose connections. Inspect all of the cooling-water pipelines and connections and check for leaks; seal any leaks found. Inspect all of the cooling-water pipelines and connections and check for corrosion and damage; repair or replace any corroded or damaged component.
2. Inspect all of the gas-ballast boost connections and check that they are secure; tighten any loose connections. Inspect all of the gas-ballast boost pipelines and connections and check for leaks; seal any leaks found. Inspect all of the gas-ballast boost pipelines and connections and check for corrosion and damage; repair or replace any corroded or damaged component.
3. Inspect all of the electrical connections and check that they are secure; tighten any loose connections. Inspect all of the electrical cables and check that they are not damaged and have not overheated; replace any damaged or overheated cable.
4. Inspect all of the vacuum connections and check that they are secure; tighten any loose connection. Inspect all of the vacuum pipelines and connections for corrosion and damage; replace any corroded or damaged components.

5.5 Change the gearbox oil

1. Refer to Figure 4. Remove the oil filler-plug (4).
2. Place a suitable container under the oil drain-plug (5).
3. Remove the oil drain-plug (5) and allow the oil to drain out of the gearbox.
4. Refit the oil drain-plug (5).
5. Dispose of the old rubber bonded seal on the oil filler-plug (4) and replace it with a new one from the pump maintenance kit.
6. Fill the gearbox through the filler-hole, with the correct grade and quantity of oil. Allow the oil to drain into the gearbox and then check the level on the oil-level sight-glass: refer to Section 5.3.
7. Ensure that the new rubber bonded seal is positioned correctly on the oil filler-plug (4), then refit the plug to the gearbox.

5.6 Relubricate the rotor bearings

Relubricate the rotor bearings as described below.

1. Refer to Figure 11. Remove the six fixing-screws (2) which secure the bearing end-cover (1) to the high vacuum head-plate.
2. Lift away the end-cover (1) and remove the sealing 'O' ring (3). Dispose of the 'O' ring (see Section 6.2).
3. Use a plastic or wooden spatula to remove as much old grease as possible from the end-cover and bearings (5). Do not use your fingers for this operation.
4. Inspect the bearings for obvious signs of wear or the presence of debris. If the bearings are worn, return the pump to a BOC Edwards Service Centre for repair.
5. If the bearings are in a satisfactory condition, force new PFPE grease (supplied in the maintenance kit) into the bearings so that a smooth layer of grease covers the case and bearings. Do not over-pack the bearings or the DP180 will run hot.
6. If you have not fitted a pump to evacuate the bearing end-cover (see Section 3.10) and you have reached the planned time to replace the head-plate felt filter (this is carried out annually), replace the filter as described in Section 5.7. Otherwise, continue at Step 7 below.
7. Apply a light wipe of PFPE grease to the new 'O' ring seal (3) and position it in its groove in the head-plate.
8. Refit the end-cover (1) to the high vacuum head-plate and secure with the six screws (2).

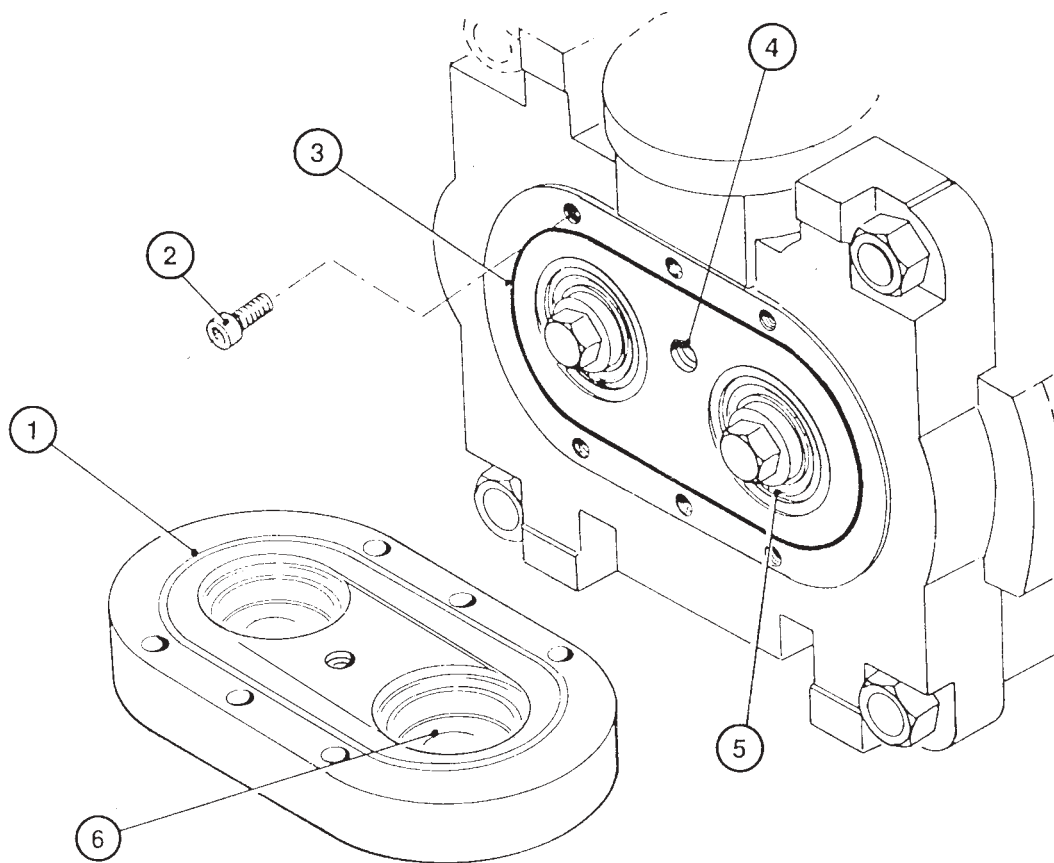

AG/0140/A

- | | |
|----------------------|---------------------|
| 1. Bearing end-cover | 4. Felt filter |
| 2. Screw | 5. Bearing |
| 3. 'O' ring | 6. End-cover cavity |

Figure 11 - Rotor bearing relubrication

5.7 Change the head-plate felt filter

If you have not connected an external pump to evacuate the bearing end-cover (see Section 3.10), you must change the felt filter in the head-plate annually. As you must remove the bearing end-cover to replace the felt filter, it is convenient to carry out this maintenance when you relubricate the rotor bearings (see Section 5.6). Use the following procedure to change the filter; this procedure assumes that you have already carried out Steps 1 to 5 in Section 5.6.

1. Refer to Figure 4. Use a suitable tool to prise out the felt filter (4) from the high vacuum head-plate. Dispose of the filter (see Section 6).
2. Place the new felt filter (supplied in the maintenance kit) into the head-plate.
3. Refit the end-cover (1) to the pump as described in Step 7 of Section 5.6.

5.8 Change the gas-ballast air filter element

If you have not connected a nitrogen gas-ballast supply to the pump, use the following procedure to replace the gas-ballast air filter element:

1. Refer to Figure 12. Turn the top-cap (1) clockwise (when viewed from the top-cap end of the gas-ballast air filter) to release it from the filter body (4), then remove the top-cap.
2. Remove and dispose of the used filter element (3).
3. Fit the new filter element (3) into the filter body (4).
4. Refit the top-cap (1) to the filter body (4) and turn it anticlockwise until it clicks, to secure it to the filter body: ensure that the inlet (2) on the top-cap does not point upwards, otherwise debris, dust or liquids may enter the filter body.

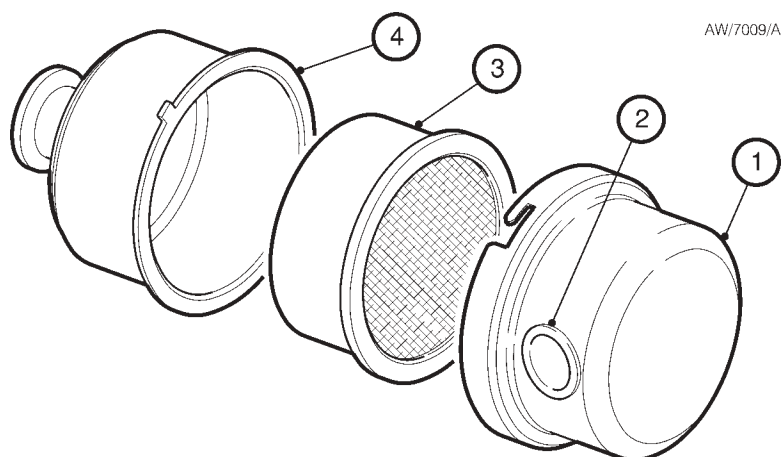

1. Top-cap
2. Inlet
3. Filter element
4. Filter body

Figure 12 - Exploded view of the gas-ballast air filter

5.9 Clean the inlet-stage sump

Clean the inlet-stage sump regularly if you use the DP180 to pump dusty or tarry vapours. Use the following procedure:

1. Remove the two screws on the clamp which secures the inlet-stage sump blanking-plate to the pump (see Figure 10).
2. Remove the clamp, the blanking-plate and the sealing 'O' ring. Dispose of the 'O' ring.
3. Use a suitable tool (for example, a flexible handled, large diameter bottle-brush) to clean the sump. Do not use your fingers for this operation.
4. Use a suitable cleaning solution to clean the blanking-plate. Make sure that all traces of the cleaning solution are removed before you refit the plate.
5. Apply a light wipe of high vacuum grease to the new 'O' ring. Refit the 'O' ring and blanking-plate to the pump, then use the clamp and the two fixing-screws to secure the blanking plate in place.

5.10 Clean the cooling-jacket

Flush the cooling-jacket to clean it; that is allow water to flow rapidly through the cooling-jacket in the reverse direction of normal flow. Use the following procedure.

1. Turn off the cooling-water supply.
2. Refer to Figure 10. Place a suitable container under the pump-body cooling-water inlet connection (8) and undo the connection. Allow the water to drain out of the pump.
3. Disconnect the water return hose from the cooling-water outlet (2).
4. Connect the cleaning water supply to the pump cooling-water outlet (2).
5. Place a suitable container under the pump-body cooling-water inlet or connect a return hose to the pump-body tapping.
6. Turn on the cleaning water supply. The pressure and flow rate of the supply should be equal to or higher than the normal cooling-water pressure and flow rate. Do not exceed the figures stated in Section 2.
7. Allow the water to flow for a few minutes, then turn off the cleaning water supply.
8. Disconnect the cleaning water supply hose (and the return hose, if fitted). Allow the water to drain out of the pump.
9. Use a suitable tool to probe the pump-body cooling-water outlet and the cooling-water inlet and remove any remaining sediment.
10. Refit the pump-body cooling-water inlet connection to the pump-body.
11. Connect the normal cooling-water supply and return hoses to the cooling-water inlet and outlet connections (refer to Section 3.6.2).
12. Prime the pump as described in Section 3.12.2.

6 STORAGE AND DISPOSAL

6.1 Storage

Store the DP180 as follows :

1. If applicable, ensure that the DP180 has been shut down as described in Section 4.2 and disconnect all services, process and exhaust connections.
2. Drain the water from the cooling-jacket as described in Section 5.10.
3. Fit blanking-plates to all vacuum inlets and outlets. Place protective covers over the pump services connection points.
4. Store the pump in clean dry conditions until required.
5. When required for use, prepare and install the pump as described in Section 3.

6.2 Disposal

Dispose of the DP180, use oil and grease and any components safely in accordance with all local and national safety and environmental requirements.

Take particular care with the following:

- Fluoroelastomers which may have decomposed as the result of being subjected to high temperatures.
- Components which have been contaminated with dangerous process substances.

7 SERVICE, SPARES AND ACCESSORIES

7.1 Introduction

BOC Edwards products, spares and accessories are available from BOC Edwards companies in Belgium, Brazil, China, France, Germany, Israel, Italy, Japan, Korea, Singapore, United Kingdom, U.S.A and a world-wide network of distributors. The majority of these centres employ Service Engineers who have undergone comprehensive BOC Edwards training courses.

Order spare parts and accessories from your nearest BOC Edwards company or distributor. When you order, please state for each part required:

- Model and Item Number of your equipment.
- Serial number (if any).
- Item Number and description of the part.

7.2 Service

BOC Edwards products are supported by a world-wide network of BOC Edwards Service Centres. Each Service Centre offers a wide range of options including: equipment decontamination; service exchange; repair; rebuild and testing to factory specifications. Equipment which has been serviced, repaired or rebuilt is returned with a full warranty.

Your local Service Centre can also provide BOC Edwards engineers to support on-site maintenance, service or repair of your equipment.

For more information about service options, contact your nearest Service Centre or other BOC Edwards company.

7.3 Spares

The following spares are available for the DP180:

Product	Item Number
DP180 spares kit	A403-02-934
DP180 seals kit	A403-02-820
DP180 tools kit	A403-02-027
Thermostatic control-valve	A500-64-000
Gas-ballast boost solenoid-valve	A287-03-012
Krytox 1525 oil (1 kg)	H113-09-018
Fomblin RT15 grease (100 g)	H113-50-003

7.4 Accessories

The accessories listed below are available for the DP180. Each accessory contains all the necessary components for assembly and installation of the accessory. Full functional descriptions and fitting details are included in the instruction manual supplied with the accessory.

Accessory	Item Number
Acoustic enclosure with vibration isolators	A500-65-000
Vibration isolators (set of 4)	A248-01-414
Exhaust-silencer	A500-71-000
Exhaust-silencer with enclosure	A500-83-000
Gas-ballast boost assembly : manual	A500-66-000
Gas-ballast boost assembly : solenoid-valve	A500-67-000
Inlet isolation-valve	B424-03-000
Inlet dust-filter	A443-03-000
Outlet flap-valve pack *	A500-72-000

*The outlet flap-valve pack contains a stainless steel flap-valve and a fluoroelastomer flap-valve.

Return of BOC Edwards Equipment - Procedure

INTRODUCTION

Before returning your equipment, you must warn BOC Edwards if substances you used (and produced) in the equipment can be hazardous. This information is fundamental to the safety of our Service Centre employees and will determine the procedures employed to service your equipment.

Complete the Declaration (HS2) and send it to BOC Edwards before you dispatch the equipment. It is important to note that this declaration is for BOC Edwards internal use only, and has no relationship to local, national or international transportation safety or environmental requirements. As the person offering the equipment for shipment, it is your responsibility to ensure compliance with applicable laws.

GUIDELINES

- Equipment is '**uncontaminated**' if it has not been used, or if it has only been used with substances that are not hazardous. Your equipment is '**contaminated**' if it has been used with any substances classified as hazardous under EU Directive 67/548/EEC (as amended) or OSHA Occupational Safety (29 CFR 1910).
- If your equipment has been used with radioactive substances, biological or infectious agents, mercury, polychlorinated biphenyls (PCB's), dioxins or sodium azide, you must decontaminate it before you return it to BOC Edwards. You must send independent proof of decontamination (for example a certificate of analysis) to BOC Edwards with the Declaration (HS2). Phone BOC Edwards for advice.
- If your equipment is contaminated, you must either:
 - Remove all traces of contamination (to the satisfaction of laws governing the transportation of dangerous/hazardous substances).
 - Or, properly classify the hazard, mark, manifest and ship the equipment in accordance with applicable laws governing the shipment of hazardous materials.

Note: Some contaminated equipment may not be suitable for airfreight.

PROCEDURE

1. Contact BOC Edwards and obtain a Return Authorisation Number for your equipment.
2. Complete the Return of BOC Edwards Equipment - Declaration (HS2).
3. If the equipment is contaminated, you must contact your transporter to ensure that you properly classify the hazard, mark, manifest and ship the equipment, in accordance with applicable laws governing the shipment of contaminated/hazardous materials. As the person offering the equipment for shipment, it is your responsibility to ensure compliance with applicable law. **Note: Equipment contaminated with some hazardous materials, such as semiconductor by-products, may not be suitable for airfreight - contact your transporter for advice.**
4. Remove all traces of hazardous gases: pass an inert gas through the equipment and any accessories that will be returned to BOC Edwards. Where possible, drain all fluids and lubricants from the equipment and its accessories.
5. Seal up all of the equipment's inlets and outlets (including those where accessories were attached) with blanking flanges or, for uncontaminated product, with heavy gauge tape.
6. Seal equipment in a thick polythene/polyethylene bag or sheet.
7. If the equipment is large, strap the equipment and its accessories to a wooden pallet. If the equipment is too small to be strapped to a pallet, pack it in a suitable strong box.
8. Fax or post a copy of the Declaration (HS2) to BOC Edwards. The Declaration must arrive before the equipment.
9. Give a copy of the Declaration (HS2) to the transporter. You must tell your transporter if the equipment is contaminated.
10. Seal the original Declaration in a suitable envelope: attach the envelope securely to the outside of the equipment package, in a clear weatherproof bag.

WRITE YOUR RETURN AUTHORISATION NUMBER CLEARLY ON THE OUTSIDE OF THE ENVELOPE OR ON THE OUTSIDE OF THE EQUIPMENT PACKAGE.

Return of BOC Edwards Equipment - Declaration

Return Authorisation Number: _____

You must:

- Know about all of the substances which have been used and produced in the equipment before you complete this Declaration
- Read the Return of BOC Edwards Equipment - Procedure (HS1) before you complete this Declaration
- Contact BOC Edwards to obtain a Return Authorisation Number and to obtain advice if you have any questions
- Send this form to BOC Edwards before you return your equipment

SECTION 1: EQUIPMENT

Equipment/System Name _____

Part Number _____

Serial Number _____

Has the equipment been used, tested or operated ?

YES Go to Section 2 NO Go to Section 4

IF APPLICABLE:

Tool Reference Number _____

Process _____

Failure Date _____

Serial Number of Replacement Equipment _____

SECTION 2: SUBSTANCES IN CONTACT WITH THE EQUIPMENT

Are any substances used or produced in the equipment:

- Radioactive, biological or infectious agents, mercury, poly chlorinated biphenyls (PCBs), dioxins or sodium azide? (if YES, see Note 1) YES NO
- Hazardous to human health and safety? YES NO

Note 1 : BOC Edwards will not accept delivery of any equipment that is contaminated with radioactive substances, biological/infectious agents, mercury, PCB's, dioxins or sodium azide, unless you:

- Decontaminate the equipment
- Provide proof of decontamination

YOU MUST CONTACT BOC EDWARDS FOR ADVICE BEFORE YOU RETURN SUCH EQUIPMENT

SECTION 3: LIST OF SUBSTANCES IN CONTACT WITH THE EQUIPMENT

Substance name	Chemical Symbol	Precautions required (for example, use protective gloves, etc.)	Action required after a spill, leak or exposure

SECTION 4: RETURN INFORMATION

Reason for return and symptoms of malfunction _____

- If you have a warranty claim:
- who did you buy the equipment from ? _____
 - give the supplier's invoice number _____

SECTION 5: DECLARATION

Print your name: _____ Print your job title: _____

Print your organisation: _____

Print your address: _____

Telephone number: _____ Date of equipment delivery: _____

I have made reasonable enquiry and I have supplied accurate information in this Declaration. I have not withheld any information, and I have followed the Return of BOC Edwards Equipment - Procedure (HS1).

Note: Please print out this form, sign it and return the signed form as hard copy.

Signed: _____ Date _____