

Instruction Manual

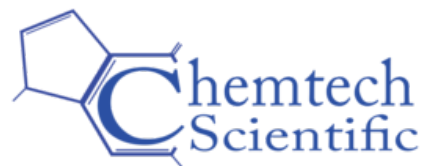

FL20K Foreline Trap

Description

FL20K

Item Number

A133-05-000



CONTENTS

Section	Title	Page
1	INTRODUCTION	1
1.1	Scope and definitions	1
1.2	General description	1
2	TECHNICAL DATA	3
2.1	Operating conditions	3
2.2	Performance	3
2.3	Mechanical data	3
3	INSTALLATION	4
3.1	Unpack and inspect	4
3.2	Install the FL20K	4
3.3	Fill the FL20K with sorbant	5
4	OPERATION	7
5	MAINTENANCE	8
5.1	Replace the sorbent charge	8
6	STORAGE AND DISPOSAL	9
6.1	Storage	9
6.2	Disposal	9
7	SPARES AND ACCESSORIES	10
7.1	Introduction	10
7.2	Spares	10
7.3	Accessories	10

Illustrations

Figure	Title	Page
1	Component parts of the FL20K	2
2	Dimensions	3
3	Component parts of the basket assembly	5

DBW 5673-96

Tables

Table	Title	Page
1	Checklist of items	4

1 INTRODUCTION

1.1 Scope and definitions

This manual provides installation, operation and maintenance instructions for the Edwards FL20K Foreline Trap. You must use the FL20K as described in this manual.

Read this manual before you install and operate the FL20K. Important safety information is highlighted as **WARNING** and **CAUTION** instructions; you must obey these instructions. The use of **WARNINGS** and **CAUTIONS** is defined below.

WARNING

Warnings are given where failure to observe the instruction could result in injury or death to people.

CAUTION

Cautions are given where failure to observe the instruction could result in damage to equipment, associated equipment and process.

The units used throughout this manual conform to the SI international system of units of measurement.

1.2 General description

The FL20K has been developed for use in clean pumping systems to prevent the back-migration of rotary pump oil vapour into the systems; we particularly recommend that you use an FL20K with two-stage rotary pumps.

The component parts of the FL20K are illustrated in Figure 1. The FL20K consists of a metal basket (4) located within a cast aluminium body (3), the metal basket is secured in place by a knurled nut (1), lid (6) and spring (5).

A sorbent is contained in the metal basket to absorb any oil which back-migrates from the pump. The sorbent material used is activated alumina which has exceptional trapping properties for oil vapour. It has a long life (up to six months) before it becomes saturated and has to be renewed.

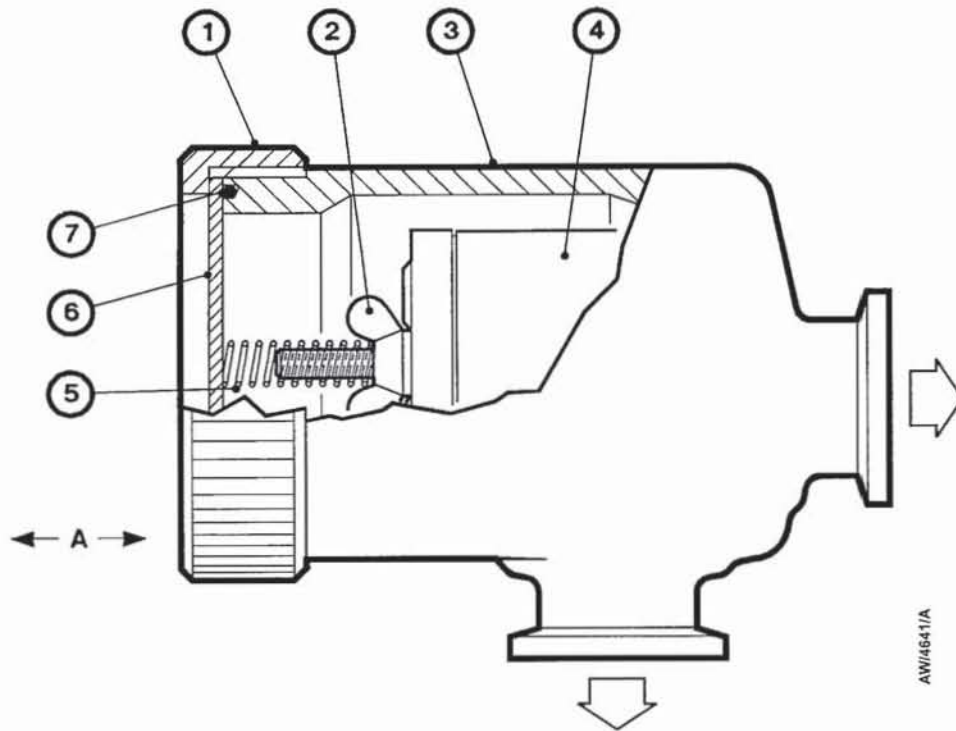

- | | |
|-------------|-----------------------|
| 1. Nut | 5. Compression spring |
| 2. Wing nut | 6. Lid |
| 3. Body | 7. 'O' ring |
| 4. Basket | |

A Clearance required for removal of basket (4)

Figure 1 - Component parts of the FL20K

2 TECHNICAL DATA

2.1 Operating conditions

Ambient operating temperature range 0 to 50 °C

2.2 Performance

Leak tightness (1 bar (1×10^5 Pa) differential) 1×10^{-6} mbar.l.s⁻¹,
 1×10^{-4} Pa.l.s⁻¹

Maximum internal pressure 1 bar absolute, 1×10^5 Pa

2.3 Mechanical data

Dimensions See Figure 2

Mass 1 kg

Sorbent charge 0.07 kg

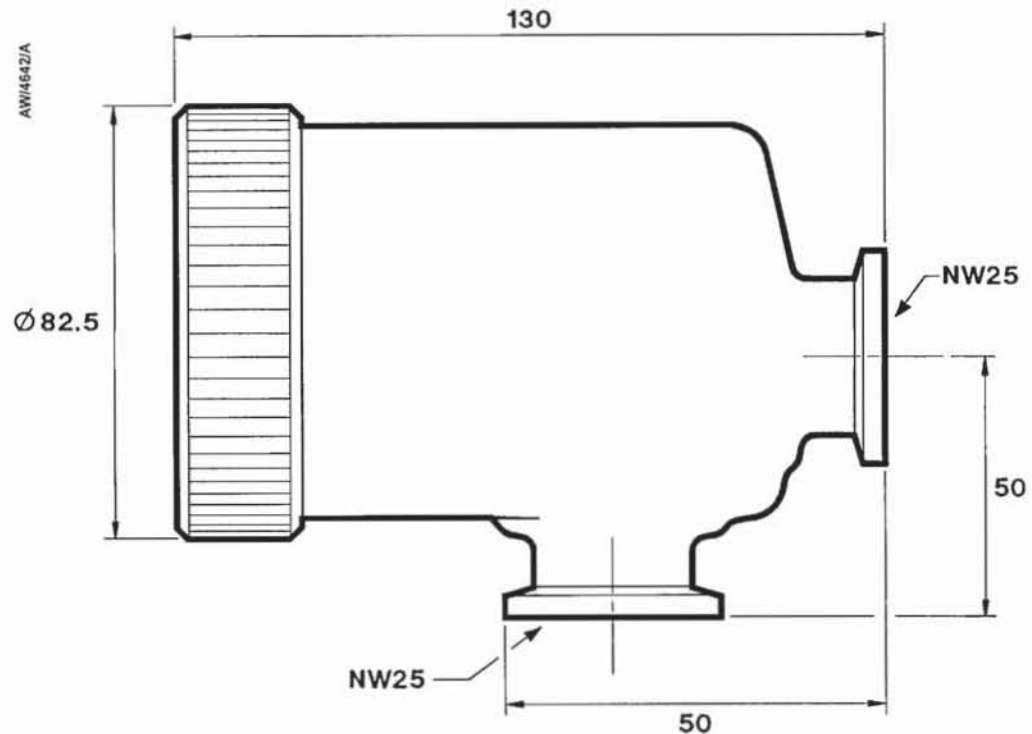

Figure 2 - Dimensions (mm)

3 INSTALLATION

3.1 Unpack and inspect

Remove all packing materials and check the FL20K. If the FL20K is damaged, notify your supplier and carrier in writing within three days; state the Item Number of the FL20K together with your order number and your supplier's invoice number. Retain all packaging materials for inspection. Do not use the FL20K if it is damaged.

Check that your package contains the items shown in Table 1. If any one of these items is missing, notify your supplier in writing within three days.

Qty	Description	Check (✓)
1	FL20K Valve	<input type="checkbox"/>
1	Tin of activated alumina	<input type="checkbox"/>

Table 1 - Checklist of items

If the FL20K is not be used immediately, return it to its protective packaging.

3.2 Install the FL20K

We recommend that you mount the FL20K horizontally, as shown in Figure 1. If necessary, however, you can mount the FL20K in any orientation, as the sorbent is securely retained in the basket. The mass of the FL20K will be adequately supported by the pipeline connections and you can connect either port to the rotary vacuum pump. However, we recommend that you mount the FL20K as close to the vacuum system and as far from the rotary pump as possible, to maximise the useful life of the sorbent. When you mount the FL20K, ensure that you leave adequate clearance to enable the sorbent basket to be removed.

Use standard KF coupling components (that is, NW clamping rings, centring rings and 'O' rings) to connect the FL20K to the pump and the vacuum system.

3.3 Fill the FL20K with sorbent

WARNING

Activated alumina is a desiccant and will absorb materials from your process system. You must take suitable precautions to protect people from the harmful effects of any noxious materials released if you bake the spent alumina to reactivate it. Avoid inhalation of its dust, eye contact and unnecessary skin contact.

CAUTION

Do not overfill the basket with sorbent. If you do, crushed sorbent could be sucked into the rotary pump and damage the pump.

1. Refer to Figure 1; unscrew and remove the nut (1) and the lid (6).
2. Remove the basket (4) and spring (5) from the trap body (3).
3. Refer to Figure 3. Remove the wing nut (9) and end cap (1) from the basket (3). Remove the washer (10), compression spring (8) and perforated end disk (7).
4. Fill the basket with sorbent; when full, the end disk (7) should align with the marker (6) on the spindle:
 - Fill the basket with alumina balls so that the top of the sorbent charge is approximately level with the marker (6).
 - Tap the basket gently to settle the sorbent, then add more alumina balls if necessary.
5. Place the perforated end disk (7) on top of the alumina balls and slide the spring (8) over the spindle (4) so that it rests on the end disk (7). Ensure that both end disks (5, 7) have their smooth side in contact with the balls.
6. Refit the washer (10) and end cap (1) over the spindle.
7. Refit the second washer (10) and wing nut (9) over the spindle (4) and tighten the wing nut (9). To ease tightening of the wing nut, push the lid down gently.

8. Position the charged basket in the trap, ensuring that it is fully located on the bottom 'O' ring seal.
9. Refer to Figure 1 and replace the spring (5), lid (6) and nut (1).

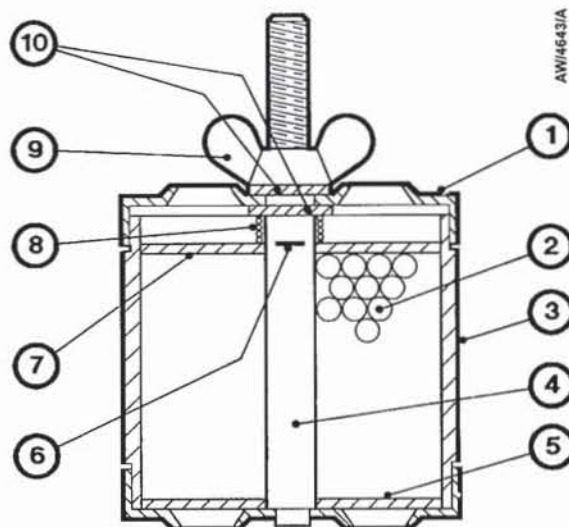

- | | |
|----------------------|-----------------------|
| 1. End cap | 6. Alignment marker |
| 2. Activated alumina | 7. End disk |
| 3. Basket | 8. Compression spring |
| 4. Spindle | 9. Wing nut |
| 5. End disk | 10. Washer (M6) |

Figure 3 - Component parts of the basket assembly

4 OPERATION

WARNING

Activated alumina is a desiccant and will absorb materials from your process system. You must take suitable precautions to protect people from the harmful effects of any noxious materials released if you attempt to reactivate spent alumina by baking. Avoid inhalation of its dust, eye contact and unnecessary skin contact.

Take note of the following information:

- In common with other types of sorbent, activated alumina absorbs moisture. This will not affect its oil vapour trapping properties but may tend to prolong rough pumping on successive pumping cycles. Regular regeneration by baking the trap or renewal of the sorbent will be necessary for rapid pump-down.
- If the FL20K has been open to atmosphere for a long period of time, it may be necessary to carry out prolonged pumping with a gas-ballasted rotary pump to remove absorbed moisture. Alternatively, remove the basket from the FL20K and bake it at 250 °C to 300 °C for two hours.
- Use a valved by-pass line to minimise vapour absorption during pump-down.

5 MAINTENANCE

5.1 Replace the sorbent charge

WARNING

Activated alumina is a desiccant and will absorb materials from your process system. You must take suitable precautions to protect people from the harmful effects of any noxious materials released if you attempt to reactivate spent alumina by baking. Avoid inhalation of its dust, eye contact and unnecessary skin contact.

During normal use, the sorbent material nearest to the port connected to the rotary pump will become brown in colour. When the discolouration reaches the sorbent layer furthest from the port, you must change the sorbent charge. The time taken for this to occur depends on the frequency of use and the location of the trap in relation to the rotary pump. A typical charge life is six months, although we recommend that you change the charge every three months as a routine maintenance procedure.

1. Refer to Figure 1. Unscrew and remove the nut (1) and the lid (6).
2. Remove the basket (4) and spring (5) from the trap body (3).
3. Refer to Figure 3. Remove the wing nut (9) and end cap (1) from the basket (3). Remove the washer (10), compression spring (8) and perforated end disk (7).
4. If the trap body interior appears oily or dirty, wash it out with iso-propyl or ethyl alcohol and then dry it thoroughly.
5. Fill the basket (3) with sorbent: refer to steps 4 to 9 of Section 3.3.

6 STORAGE AND DISPOSAL

6.1 Storage

1. Return the FL20K to its protective packaging.
2. Store the FL20K in clean dry conditions, away from direct sources of heat and sunlight.

6.2 Disposal

Dispose of the FL20K safely in accordance with all local and national safety and environmental requirements.

7 SPARES AND ACCESSORIES

7.1 Introduction

Edwards products, spares and accessories are available from Edwards companies in Belgium, Brazil, Canada, France, Germany, Hong Kong, Italy, Japan, Korea, Switzerland, United Kingdom, U. S. A, and a world wide network of distributors. The majority of these centres employ people who have undergone comprehensive Edwards training courses.

Order spare parts and accessories from your nearest Edwards company or distributor. When you order, please state for each part required:

- Model and Item Number of your equipment
- Serial Number (if any)
- Item Number and description of part

7.2 Spares

Description	Item Number
0.45 kg activated alumina	H026-00-050

7.3 Accessories

Description	Item Number
Stainless steel clamping ring - NW20/25	C105-14-401
Polymer clamp - NW20/25	C105-14-403
Centring ring and 'O' ring - NW25 (polymer with nitrile 'O' ring)	C105-14-393
Centring ring and 'O' ring - NW25 (stainless steel with nitrile 'O' ring)	C105-14-396
Centring ring and 'O' ring - NW25 (polymer with fluoroelastomer 'O' ring)	C105-14-394
Centring ring and 'O' ring - NW25 (stainless steel with fluoroelastomer 'O' ring)	C105-14-395
Changeover valve	C079-02-000

Return of Edwards Equipment - Procedure (Form HS1)

Introduction

Before you return your equipment you must warn your supplier if the substances you used (and produced) in the equipment can be dangerous. You must do this to comply with health and safety at work laws.

You must complete the Declaration (HS2) on the next page and send it to your supplier before you dispatch the equipment. If you do not, your supplier will assume that the equipment is dangerous and he will refuse to accept it. If the Declaration is not completed correctly, there may be a delay in processing your equipment.

Guidelines

Take note of the following guidelines:

- Your equipment is 'uncontaminated' if it has not been used or if it has only been used with substances that are not dangerous. Your equipment is 'contaminated' if it has been used with any dangerous substances.
- If your equipment has been used with radioactive substances, you must decontaminate it before you return it to your supplier. You must send independent proof of decontamination (for example a certificate of analysis) to your supplier with the Declaration (HS2). Phone your supplier for advice.
- We recommend that contaminated equipment is transported in vehicles where the driver does not share the same air space as the equipment.

PROCEDURE

Use the following procedure:

1. Contact your supplier and obtain a Return Authorisation Number for your equipment.
2. Turn to the next page(s), photocopy and then complete the Declaration (HS2)
3. Remove all traces of dangerous gases: pass an inert gas through the equipment and any accessories which will be returned to your supplier. Drain all fluids and lubricants from the equipment and its accessories.
4. Disconnect all accessories from the equipment. Safely dispose of the filter elements from any oil mist filters.
5. Seal up all of the equipment's inlets and outlets (including those where accessories were attached). You may seal the inlets and outlets with blanking flanges or heavy gauge PVC tape.
6. Seal contaminated equipment in a thick polythene bag. If you do not have a polythene bag large enough to contain the equipment, you can use a thick polythene sheet.
7. If your equipment is a large pump (or any other large piece of equipment), strap the equipment and its accessories to a wooden pallet. Preferably, the pallet should be no larger than 510mm x 915mm (20" x 35"); contact your supplier if you cannot meet this requirement.
8. If your equipment is too small to be strapped to a pallet, pack it in a suitable strong box.
9. If the equipment is contaminated, label the pallet (or box) in accordance with laws covering the transport of dangerous substances.
10. Fax or post a copy of the Declaration (HS2) to your supplier. The Declaration must arrive before the equipment.
11. Give a copy of the Declaration to the carrier. You must tell the carrier if the equipment is contaminated.
12. Seal the original Declaration in a suitable envelope; attach the envelope securely to the outside of the equipment package. **WRITE YOUR RETURN AUTHORISATION NUMBER CLEARLY ON THE OUTSIDE OF THE ENVELOPE OR ON THE OUTSIDE OF THE EQUIPMENT PACKAGE.**

