

## 1 REPLACE THE TIP SEALS

This instruction is applicable to the XDS replacement tip seal kit (Code Number A726-01-805), which can be used in any of the XDS5, XDS10, XDS5-C or XDS10-C scroll pumps. Refer to Figure 1 and replace the components as described below.

1. Switch off the pump, isolate the electrical supply and allow it to cool to a safe temperature.
2. Undo the 4 screws (410) and 4 washers (412) which secure the fan-cowl (113) to the pump-body. Remove the fan-cowl and the fixed scroll together, being careful to lift them away in line with the motor body. Both tip seals (402) will now be exposed. Dispose of the tip seals in accordance with all local and national safety and environmental requirements. If the pump has been used for anything other than clean applications, go to step 3; if not move straight on to step 14.
3. Loosen the 3 screws (130) which clamp the fixed scroll (101) to the fan cowl (113). Swivel the clamping plates (115) away from the fixed scroll, to allow the fan cowl to be lifted off the fixed scroll.

For XDS pumps pre serial number 037874870 (XDS5) or 037869927 (XDS10) read steps 4 to 8 and then continue at step 13, for XDS pumps post serial number 037874870 (XDS5) or 037869927 (XDS10) continue at step 9.

4. The exhaust duct (105<sup>#</sup>) is now exposed on the outside of the fixed scroll. If the pump is an XDS-C, remove the 5 screws (117) and washers (116) securing this, and lift the exhaust duct (105<sup>#</sup>) away from the fixed scroll. If the pump is an XDS, remove the 7 screws (117) and washers (116) securing this, and lift the exhaust duct (105<sup>#</sup>) away from the fixed scroll.
5. Remove the 'O' ring (121<sup>#</sup>), valve pad (109) and spring (124). Dispose of these items in accordance with all local and national safety and environmental requirements.

6. Separate the exhaust flange (102) from the exhaust duct (105<sup>#</sup>), exposing the exhaust duct 'O' ring. If you have an XDS pump, these components are plastic and the 'O' ring is 128. On an XDS-C pump they are stainless steel, and the 'O' ring is 137. 'O' ring 128 is smaller than 'O' ring 137. Replace this 'O' ring and dispose of the old one. Reconnect the exhaust flange (102) and exhaust duct (105<sup>#</sup>).
7. Fit the 'O' ring (121<sup>#</sup>) into the 'O' ring groove around the exhaust hole. Fit the exhaust spring (124) over the back of the valve pad (109). Seat the exhaust valve (109) back into the hole on the fixed scroll, so that the spring stands perpendicular to the scroll.
8. Replace the exhaust ducting, taking care not to dislodge the exhaust valve and spring. Replace the 7 screws (117) and washers (116).
9. The exhaust cover (105\*) is now exposed on the outside of the fixed scroll. Remove the 3 screws (117) and washers (116) securing this, and lift the exhaust cover away from the fixed scroll.
10. Remove the 'O' ring (121\*), valve pad (109) and spring (124). Dispose of these items in accordance with all local and national safety and environmental requirements.
11. Fit the replacement 'O' ring (121\*) into the groove on exhaust cover (105\*). Fit the exhaust spring (124) over the back of the valve pad (109). Fit the assembled exhaust pad (109) and exhaust spring (124) onto the exhaust cover's (105\*) spigot.
12. Replace this assembly back into the fixed scroll taking care to align the pad centrally. Whilst applying light pressure to the back of the exhaust cover, replace the 3 screws (117) and washers (116).
13. Place the fixed scroll back into the fan cowl (113). Ensure that the fan connector and mounting bracket are fitted correctly, so that the fan connector is restrained by the bracket when the fixed scroll is in place. Swivel the clamp plates (115) into the cut-outs on the fixed scroll, and re-tighten the screws (130) to secure the fan cowl (113) on to the fixed scroll (101).

## XDS Replacement Tip Seal Kit

PAGE  
2

### REPLACE THE TIP SEALS

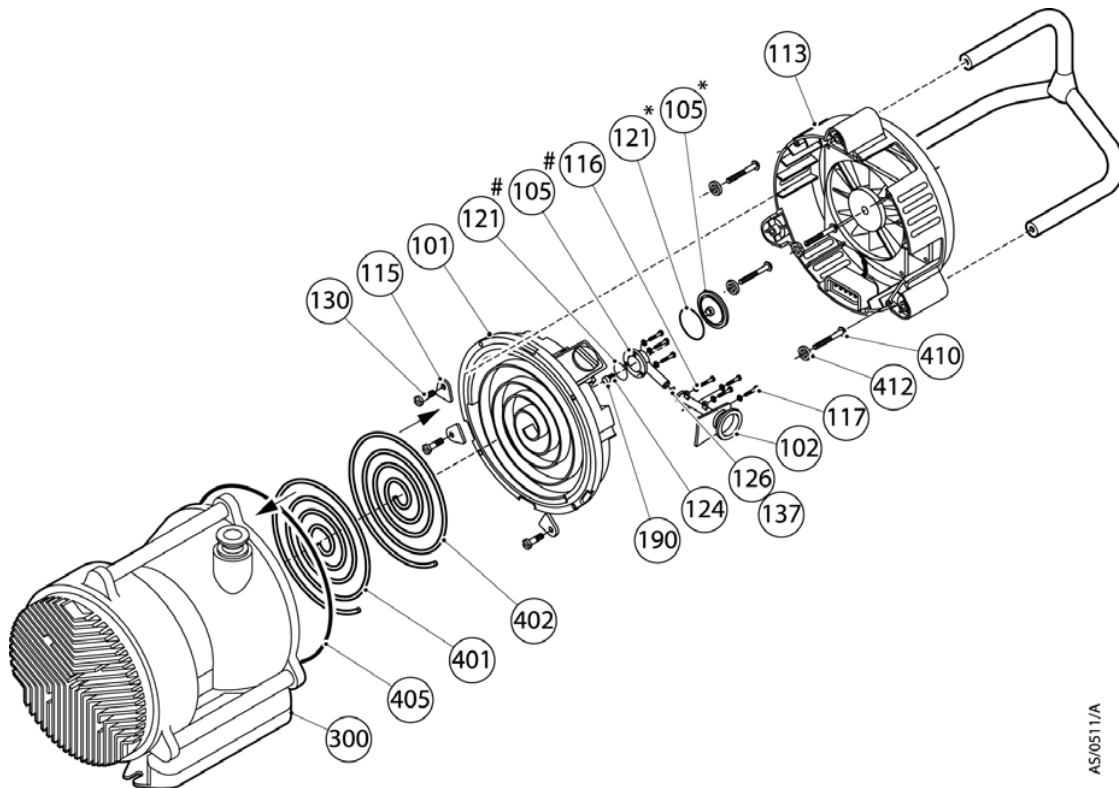

AS/0511/A

Figure 1 - Replacing the tip seals

14. Make sure that there is no debris visible on the inside of the scrolls, especially in the tip seal slot. Wipe with a soft, dry, lint-free cloth to remove any dust etc.
15. Take a tip seal (402), and starting at the centre of the scroll, fit it into the slot in the orbiting scroll. This tip seal is longer than required, so must be cut to the correct length. The tip seals have a special surface finish on the sealing face and minute grooves in the opposite face. When fitting the tip seal, ensure that the grooved face is down in the slot. Make sure that the tip seal is pushed fully home, particularly at the pinch-point towards the centre of the scroll.
16. Repeat step 15, using the remaining tip seal (402) in the fixed scroll (101).
17. Replace the large 'O' ring (405) on the perimeter of the motor assembly (300).
18. Offer the fixed scroll to the motor. Take care that the tip seals do not drop out during assembly. Replace the 4 screws (410) and 4 washers (412) and tighten.
19. Connect the pump to the electrical supply, and check that the electric fan is running, by feeling for air flow at the fan cowl.

Some period of running-in may be required before optimum performance is reached. Depending on the application, the vacuum achieved directly following a tip seal replacement may be sufficient for your requirements. Typically, this can be up to a decade more than the final vacuum achievable with a bedded in tip seal.