

Instruction Manual

Micro Tool Interface



Description	Item Number
SPI Micro-TIM	D373-60-310
MCM Micro-TIM	D373-60-320
TEL Micro-TIM	D373-60-330
SEMI E73 Micro-TIM	D373-60-340
LAM Alliance Micro-TIM	D373-60-350
Novellus C3 Micro-TIM	D373-60-360
Hitachi Micro-TIM	D373-60-370

Chemtech Scientific provides access to this content as a courtesy.
We do not own the content contained in this document.
All rights and credit go directly to its rightful owners.
www.chemtechsci.com
Call us at: 484-424-9415



Contents

Section	Page
1 INTRODUCTION	1
1.1 Scope	1
1.2 Description	1
1.3 Pump System Connection	2
1.4 The Tool Interface Connectors	2
2 TECHNICAL DATA	3
2.1 General	3
2.2 Electrical Data	3
2.3 Electrical Connectors	3
3 INSTALLATION	4
3.1 Unpack and Inspect	4
3.2 Fit the Micro TIM	4
3.3 Parallel Interface Connections	4
4 OPERATION	6
4.1 Introduction	6
4.2 Inputs	6
4.2.1 Inputs (except for GXS and CXS)	6
4.2.2 GXS/CXS Inputs	7
4.3 Outputs	7
4.3.1 Outputs (except for GXS and CXS)	7
4.3.2 GXS/CXS outputs	9
4.4 Setpoints and Configuration Parameters	9
4.5 Take and Release Control	10
5 MAINTENANCE	11
5.1 Inspect the Electrical Connections	11
5.2 Fault Finding	11
6 STORAGE AND DISPOSAL	12
6.1 Storage	12
6.2 Disposal	12
7 SPARES AND ACCESSORIES	13
7.1 Service	13
7.2 Spares	13
7.3 Accessories	13
For return of equipment, complete the HS Forms at the end of this manual.	

Illustrations

Figure	Page
1 Micro TIM	5

Tables

Table	Page
1 Checklist of Items	4
2 Parallel Interface Inputs	6
3 GXS/CXS Parallel interface inputs	7
4 Parallel Interface Outputs	8
5 GXS/CXS parallel interface outputs	9
6 Fault Finding	11
7 Cable Back Shell Identity	13

Associated Publications

Publication Title	Publication number
Vacuum Pump and Vacuum System Safety	P300-20-000

1 INTRODUCTION

1.1 Scope

This manual provides installation, operation and maintenance instructions for the Edwards Micro Tool Interface Module (Micro TIM). You must use the Micro TIM as specified in this manual.

Read this manual before you attempt to install, operate and maintain the Edwards Micro TIM. Important safety information is highlighted as WARNING and CAUTION instructions; you must obey these instructions. The use of WARNINGS and CAUTIONS is defined below.



WARNING

Warnings are given where failure to observe the instruction could result in injury or death to people.

CAUTION

Cautions are given where failure to observe the instruction could result in damage to the equipment, associated equipment and process.

The units used throughout this manual conform to SI international system of measurement followed by imperial units in parenthesis; SI (imperial).

In accordance with the recommendations of IEC61010, the following warning symbol appears on the Micro TIM:



Warning - refer to accompanying documentation.

1.2 Description



WARNING

Edwards takes no responsibility for damage or injury caused by improper use of the equipment.

There are several types of Micro TIM available, each provides different Tool Interface Connector functionality, select the interface according to your tool requirements.

All variants of the Micro TIM, allow you to control the operation and monitor the status of the pumping system through a parallel interface, connected to your process tool.

Note: All information sent by or received from the Micro TIM, is software derived.

On many Edwards pump systems, the Micro TIM can store any custom pump set-up for your tool. If enabled, this facility will automatically set-up an exchanged pump of the same type, providing the Micro TIM is transferred to the new pump. Further information is provided with the pump configuration tools.

1.3 Pump System Connection

Refer to [Figure 1](#). The Micro TIM is automatically connected to the pumping system by inserting it into the tool interface slot in the pump body. Refer to [Section 3.2](#) for the installation instructions.

To avoid damaging the pump connections, it should be returned to its packaging when not inserted in the interface slot.

CAUTION

Damage to the Micro TIM may result if connection is made to any other connector on the pumping system.

1.4 The Tool Interface Connectors

The Tool Interface Connectors allow you to control the operation and to monitor the status of the pumping system.

Refer to [Section 2.3](#) for details of the connections and [Section 4](#) for details of how to use the Tool Interface Connectors.

If the Tool Interface requires Emergency Stop connections, these are available fitted on an optional protection box, refer to the instruction manual for your pump.

2 TECHNICAL DATA

2.1 General

Maximum mass	500 g
Operating temperature range	+5 to 50 °C
Storage temperature range	-20 to 70 °C
Operating humidity range	10 to 90% RH at 40 °C
Maximum storage humidity	20 to 90% RH at 40 °C (Non Condensing)
Maximum operating altitude	2000 m

2.2 Electrical Data

Inputs: Voltage	a.c./d.c. input signal
High input voltage threshold	> 20 V
Low input voltage threshold	< 5 V
Volt-free contact	Volt-free (dry) contacts
External contact rating	24 V
Sense current	5 mA
Outputs: Type	Volt-free (dry) contacts, normally open
Rating	24 V, 1 A max.

2.3 Electrical Connectors

SPI	16-way CPC plug
MCM	16-way CPC plug
TEL	25-way 'D-type' plug
E73	15-way 'D-type' socket
LAM	25-way 'D-type' socket
C3	9-way 'D-type' plug
HIT	37-way 'D-type' plug

3 INSTALLATION

3.1 Unpack and Inspect

Remove all of the packaging materials and check the Micro TIM. If the Micro TIM is damaged, notify your supplier and the carrier in writing within three days, stating the item number of the Micro TIM together with your order number and your supplier's invoice number. Do not use the Micro TIM if it is damaged.

Check that you have received the items listed in Table 1. If any item is missing, notify your supplier in writing within three days. If you will not use the Micro TIM immediately, replace any packing materials and store it in suitable conditions, as described in Section 6 of this instruction manual.

Table 1 - Checklist of Items

Quantity	Description	Check (✓)
1	Micro TIM	<input type="checkbox"/>
2	Micro TIM Instruction Manual	<input type="checkbox"/>

3.2 Fit the Micro TIM

Before the Micro TIM is fitted, the electrical supply to the pumping system must be isolated.

CAUTION

The Micro TIM and the pumping system may be damaged if they are connected or disconnected while the pump is powered

The Micro TIM is fitted directly to the pumping system.

Fit the Micro TIM as follows:

1. If fitted, remove the blank or existing Micro TIM by releasing the captive locking screws and pulling the module out.
2. Offer up the Micro TIM, making sure it is the correct way up. The correct position of the serial number is shown in Figure 1. Internal plastic guides ensure the Micro TIM is correctly aligned with the connector. If a high resistance is experienced, re-check the alignment; do not use excessive force.

Note: When installing a Micro TIM into a Mini System Controller the serial number must face downwards.

3. Check that the sealing gasket is correctly seated and hand tighten the captive locking screws firmly to ensure a watertight seal; do not use a tool to tighten the captive locking screws.

3.3 Parallel Interface Connections

Note: Refer to Section 4 to determine the signals used in the parallel cable.

1. Make a suitable parallel cable. Refer to Section 7.3 for back shell kits if required.
2. Connect one end of the parallel cable to your control equipment.
3. Connect the other end of the parallel cable to the Micro TIM.

Note: Ensure that all electrical wiring is safely secured so that people cannot trip on them. If you do not, they may cause injury to people

Figure 1 - Micro TIM

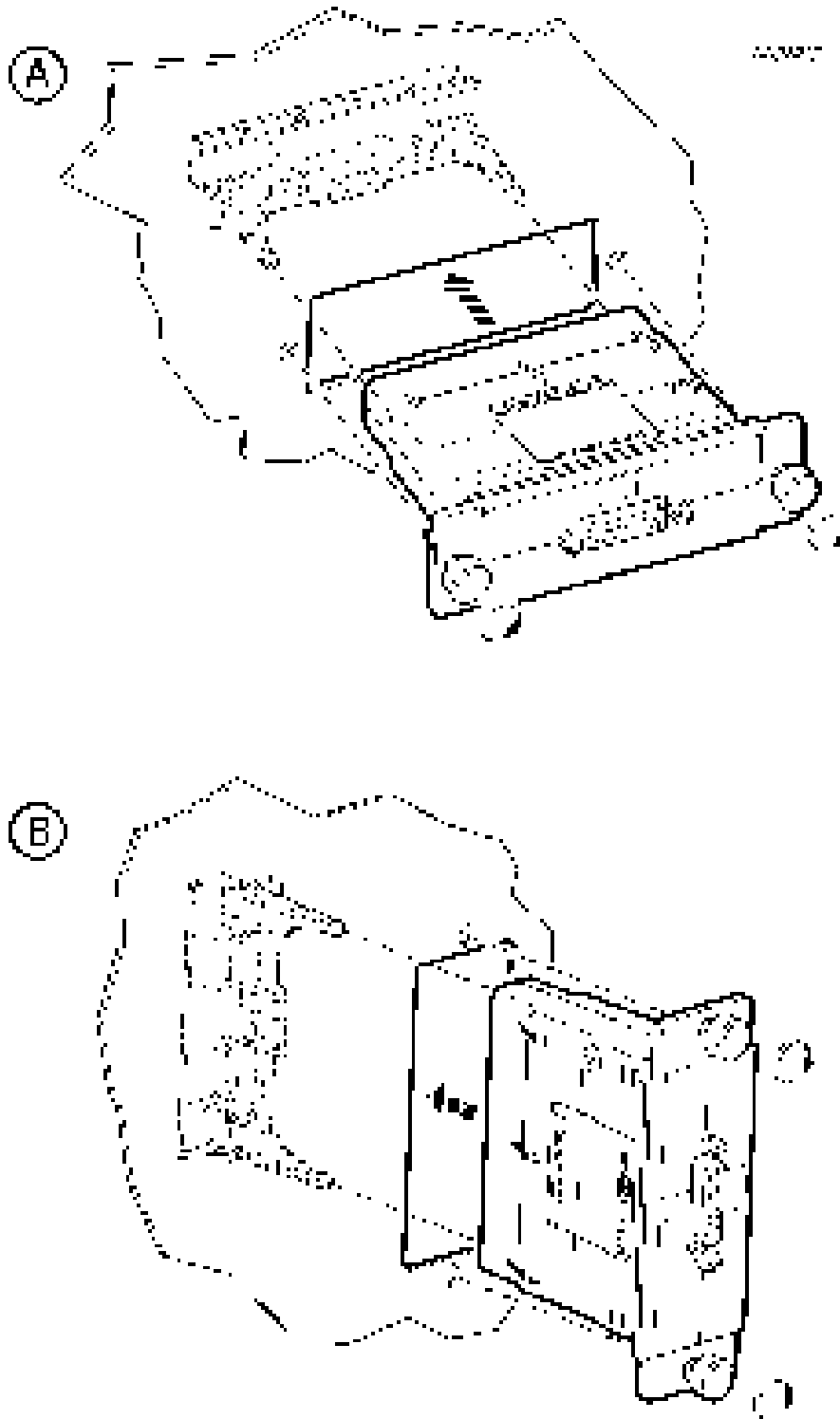

4 OPERATION

4.1 Introduction

Use the parallel interface to monitor and control the pumping system as described in the following sub-sections. Where necessary, refer to the instruction manual supplied with your pumping system, and to the instruction manual(s) supplied with other pumping system components.

4.2 Inputs

4.2.1 Inputs (except for GXS and CXS)

Table 2 defines the default input signals to the pump system.

Note: At least 10 seconds must be allowed between successive set / reset inputs. Volt-free contact inputs should not be linked together.

Table 2 - Parallel Interface Inputs

Function	Signal type	Pins	Operation
Both Pumps On / Off*	Voltage input	SPI - 1 and 2 MCM - 1 and 2 LAM - 10 and 23 C3 - 2 and 6	Both pumps run when voltage applied.
	Volt-free contact input	MCM - 5 and 6 TEL - 1 and 14 HIT - 7 and 26	Both pumps run when contact closed.
Dry Pump On / Off	Volt-free contact input	E73 - 1 and 9 HIT - 1 and 20	Dry Pump runs when contact closed.
Mechanical Booster On / Off^	Volt-free contact input	E73 - 2 and 10 HIT - 2 and 21	Mechanical Booster runs when contact closed.
Active Utility Control (AUC)	Voltage input	SPI - 5 and 6 MCM - 15 and 16 LAM - 11 and 24 C3 - 1 and 6	Pump(s) set to AUC mode when voltage applied.
	Volt-free contact input	MCM - 13 and 14 TEL - 2 and 15 E73 - 2 and 8 HIT - 3 and 22	Pump(s) set to AUC mode when contact closed.
Run Til Crash	Volt-free contact input	TEL - 4 and 17 HIT - 5 and 24	Pump(s) set to Run Til Crash when contact closed.
Auto / Fast Shutdown	Volt-free contact input	TEL - 5 and 18 HIT - 6 and 25	Pump(s) set to Auto Shutdown when contact closed.
Open / Close Gate Valve	Volt-free contact input	TEL - 3 and 16 HIT - 4 and 23	Gate Valve set to Open when contact closed.
Speed Control	Variable d.c. voltage input	SPI - 15 (+) and 16 (-)	Pump speed reduced when voltage applied.

* If a Mechanical Booster Pump has not been fitted then this function will only operate the Dry Pump.

^ The Mechanical Booster Pump will not start unless the Dry Pump is on. This input is ignored if no Mechanical Booster Pump is fitted to the pumping system.

4.2.2 GXS/CXS Inputs

GXS/CXS should only use the MCM Micro TIM.

Note: At least 10 seconds must be allowed between successive set/reset inputs. Volt-free contact inputs should not be linked together.

Table 3 - GXS/CXS Parallel interface inputs

Channel	Function	Signal type	Pins	Operation
1	Both Pumps On/Off *	Voltage input	1 and 2	Both pumps run when voltage applied.
		Volt-free contact input	5 and 6	Both pumps run when contact closed.
2 # (default)	Active Utility Control (AUC)	Voltage input	15 and 16	Pump(s) set to AUC mode when voltage applied.
		Volt-free contact input	13 and 14	Pump(s) set to AUC mode when contact closed.
2 #	Mechanical Booster On/Off ^#	Voltage input	15 and 16	Mechanical Booster runs when voltage applied.
		Volt-free contact input	13 and 14	Mechanical Booster runs when contact closed.
2 #	Open/Close Isolation Valve #	Voltage input	15 and 16	Isolation Valve set to Open when voltage applied.
		Volt-free contact input	13 and 14	Isolation Valve set to Open when contact closed.
2 #	PID Enable/Disable	Voltage input	15 and 16	PID enabled when voltage applied.
		Volt-free contact input	13 and 14	PID enabled when contact closed.
2 #	Second Speed Enable/Disable	Voltage input	15 and 16	Second speed enabled when voltage applied.
		Volt-free contact input	13 and 14	Second speed enabled when contact closed.

* If a Mechanical Booster Pump has not been fitted then this function will only operate the Dry Pump.

^ The Mechanical Booster Pump will not start unless the Dry Pump is on. This input is ignored if no Mechanical Booster Pump is fitted to the pumping system.

Options for channel 2. Only 1 can be active at a time.

4.3 Outputs



WARNING

Output information should not be used for safety critical purposes.

4.3.1 Outputs (except for GXS and CXS)

All output signals are volt-free contacts. Table 4 defines the default status signals output from the pump system.

Note: All outputs are maintained through a power loss of up to 1 second. All output contacts open if power is permanently removed.

Table 4 - Parallel Interface Outputs

Function	Pins	Operation
Both Pumps Running	SPI - 3 and 4 MCM - 3 and 4 TEL - 8 and 20 LAM - 2 and 15 C3 - 5 and 9 HIT - 19 and 37	Closed when pumps on.
Dry Pump Running	E73 - 3 and 11 HIT - 12 and 30	Closed when Dry Pump is on.
Mechanical Booster Running	E73 - 4 and 12 HIT - 13 and 31	Closed when Mechanical Booster is on.
General Warning	SPI - 7 and 8 MCM - 7 and 8 TEL - 9 and 21 E73 - 5 and 13 C3 - 4 and 8 HIT - 14 and 32	Closed when no Warning condition exists (warnings to pass on to the tool are selectable using the configuration handler on some pumps).
Alarm	SPI - 9 and 10 MCM - 9 and 10 TEL - 10 and 22 E73 - 6 and 14 LAM - 1 and 14 C3 - 3 and 7 HIT - 15 and 33	Closed when no Alarm condition exists (alarms to pass on to the tool are selectable using the configuration handler on some pumps).
Gas Flow Warning	SPI - 11 and 12 MCM - 11 and 12 TEL - 11 and 23 HIT - 16 and 34	Closed when no Gas Purge Flow warning condition exists (Closed if no gas module present).
LAM Warning	LAM - 3 and 16	Closed when no General or Gas Purge Flow warning condition exists (warnings selectable using configurations on some pumps).
Exhaust Pressure Warning	TEL - 13 and 25 HIT - 18 and 36	Closed when no Exhaust Pressure warning condition exists.
Water Flow Warning	TEL - 12 and 24 HIT - 17 and 35	Closed when no Water Flow warning condition exists.
Pump Status / Final Valve	SPI - 13 and 14	Closed when pump running and no Gas Purge Flow warning exists.
Remote / Local Control Status	E73 - 7 and 15	Closed when remote control is available through the tool interface.

4.3.2 GXS/CXS outputs

GXS/CXS should only use the MCM Micro TIM.

All output signals are volt-free contacts. Table 5 defines the default status signals output from the pump system.

Note: All outputs are maintained through a power loss of up to 1 second.
All output contacts open if power is permanently removed.

Table 5 - GXS/CXS parallel interface outputs

Channel	Function	Pins	Operation
1	Dry Pump Running	3 and 4	Closed when Dry Pump is on.
2	System Ready	7 and 8	Closed when system at temperature and no warnings present.
3	Alarm	9 and 10	Closed when no Alarm condition exists (alarms to pass on to the tool are selectable using the configuration handler on some pumps).
4 # default	Isolation valve is open *	11 and 12	Closed when valve is open. If no position switch is fitted to the valve then closed when valve is commanded to open.
4 #	General Warning	11 and 12	Closed when no Warning condition exists (warnings to pass on to the tool are selectable using the configuration handler on some pumps).
4 #	Mechanical Booster Running *	11 and 12	Closed when Mechanical Booster is on.
4 #	Nitrogen Flow Warning *	11 and 12	Closed when no Nitrogen Flow warning condition exists.
4 #	Water Flow Warning *	11 and 12	Closed when no Water Flow warning condition exists.
4 #	Exhaust Pressure Warning *	11 and 12	Closed when no Exhaust Pressure warning condition exists.
4 #	Remote/Local Control Status	11 and 12	Closed when remote control is available through the tool interface.

* Will only function if optional component is fitted.

Options for channel 4. Only 1 can be active at a time.

4.4 Setpoints and Configuration Parameters

If your pumping system has the capability, parameter settings may be saved to memory in the Micro TIM. Whenever you switch on the pumping system, the information in the store is automatically sent to the pumping system and overwrites the setpoints already in the system.

To put new information in the store, you must download the new information from a PC, using the Single Equipment Monitor (refer to the pumping system instruction manual).

Note: If the Micro TIM is connected to a pumping system, setpoint information stored for another pump type will not be downloaded to the pumping system.

4.5 Take and Release Control

When the Micro TIM is used to control the operation of the pump, it will try to take control. Your pumping system may have additional pumping system modules that can also take control, for example manual pump start buttons on the front of the pump. The Micro TIM can only take control if no other pumping system module already has control.

Once the Micro TIM has control, no other module can operate the pumping system until it releases control. In normal operation, the parallel interface only releases control when it is used to switch off the pumping system.

Note: *If an alarm condition occurs whilst the Micro TIM has control, it will release control. Another module may then be used to clear the alarm.*

5 MAINTENANCE

5.1 Inspect the Electrical Connections

Carry out the following checks regularly when maintaining the pumping system:

1. Check the Micro TIM and ensure that it is securely fixed in place.
2. Inspect the electrical cables and check that they are not damaged and have not overheated. Repair or replace any damaged or overheated cable found.
3. Inspect the electrical connections and check that they are secure. Tighten any loose connections found.

5.2 Fault Finding

Table 6 - Fault Finding

Check	Action
Is the control equipment operating?	Ensure that the electrical supply to the pumping system is switched on and that the control equipment is switched on.
Is control available to the Micro TIM?	Ensure that no user interfaces, such as the Pump Display Terminal, are in control.
Are the communications cables connected?	Ensure that the parallel cables are correctly connected to the pumping system and to the control equipment.
Are the cables wired correctly?	Ensure that the wires of the parallel cables are correctly connected to the pumping system and the control equipment connectors.

6 STORAGE AND DISPOSAL

6.1 Storage

Replace any protective packing materials and store the Micro TIM in clean dry conditions.

When required for use, install the Micro TIM as described in [Section 3](#).

6.2 Disposal

Dispose of the Micro TIM and any other components safely in accordance with all local and national safety and environmental requirements.

7 SPARES AND ACCESSORIES

7.1 Service

A worldwide network of Edwards Service Centres supports Edwards products. Each Service Centre offers a wide range of options including equipment decontamination; service exchange; repair; rebuild and testing to factory specifications. Equipment, which has been serviced, repaired or rebuilt, is returned with full warranty.

For more information about service options, contact your nearest Service Centre or other Edwards company

7.2 Spares

Order spare parts and accessories from your nearest Edwards company or distributor. When you order, please state for each part required:

- Model and Item Number of your equipment.
- Serial Number (if any).
- Item Number and description of the part.

7.3 Accessories

Table 7 shows the range of accessories that can be purchased.

Note: Plug / Socket designation refers to the pins of the cable connector which mates with the Micro TIM connector.

Table 7 - Cable Back Shell Identity

Identification	Item Number	Tool Cable Connector	Back Shell Kit Item Number
SPI	D373-60-310	CPC 16/17 Socket	D374-20-801
MCM	D373-60-320	CPC 16/17 Socket	D374-22-802
TEL	D373-60-330	25w D Type Socket	D374-20-802
E73	D373-60-340	15w D Type Plug	D374-20-803
LAM	D373-60-350	25w D Type Plug	D374-22-801
C3	D373-60-360	9w D Type Socket	D374-21-803
HIT	D373-60-370	37w D Type Socket	D374-21-804