

Instruction Manual

E1M18 and E2M18 Rotary Vacuum Pumps

<i>Description</i>	<i>Item Number</i>
<i>E1M18, 100/200 V, 50 Hz or 100-105/200-210 V, 60 Hz, single-phase</i>	<i>A343-15-904</i>
<i>E1M18, 115/230 V, 60 Hz, single-phase</i>	<i>A343-15-981</i>
<i>E1M18, 220 V, 50/60 Hz, single-phase</i>	<i>A343-15-920</i>
<i>E1M18, 220-240 V, 50 Hz, single-phase</i>	<i>A343-15-912</i>
<i>E1M18, 220-240 V, 50 Hz, or 230-240 V, 60 Hz, single-phase</i>	<i>A343-15-903</i>
<i>E1M18, 200-230/380-460 V, 50/60 Hz, three-phase</i>	<i>A343-10-940</i>
<i>E1M18, 220-240 V, 50 Hz, or 230-240 V, 60 Hz, single-phase (Amphenol)</i>	<i>A343-16-903</i>
<i>E1M18, 110/200-240 V, 50 Hz, or 115-120/200-230 V, 60 Hz, single-phase</i>	<i>A343-17-984</i>
<i>E2M18, 100/200 V, 50 Hz or 100-105/200-210 V, 60 Hz, single-phase</i>	<i>A363-15-904</i>
<i>E2M18, 115/230 V, 60 Hz, single-phase</i>	<i>A363-15-981</i>
<i>E2M18, 220 V, 50/60 Hz, single-phase</i>	<i>A363-15-920</i>
<i>E2M18, 220-240 V, 50 Hz, single-phase</i>	<i>A363-15-912</i>
<i>E2M18, 220-240 V, 50 Hz, or 230-240 V, 60 Hz, single-phase</i>	<i>A363-15-903</i>
<i>E2M18, 200-230/380-460 V, 50/60 Hz, three-phase</i>	<i>A363-10-940</i>
<i>E2M18, 110/200-240 V, 50 Hz, or 115-120/200-230 V, 60 Hz, single-phase</i>	<i>A363-17-984</i>
<i>E2M18-FF, 200-230/380-460 V, 50/60 Hz, three-phase</i>	<i>A363-21-940</i>
<i>E2M18-FF, 100/200 V, 50/60 Hz, single-phase</i>	<i>A363-25-904</i>
<i>E2M18, 220-240 V, 50 Hz, single-phase</i>	<i>A363-25-912</i>

Chemtech Scientific provides access to this content as a courtesy.

We do not own the content contained in this document.

All rights and credit go directly to its rightful owners.

www.chemtechsci.com

Call us at: 484-424-9415



CONTENTS

Section		Page
1	INTRODUCTION	1
1.1	Scope and definitions	1
1.2	ATEX directive implications	2
1.3	Description	4
1.4	Gas-ballast	4
2	TECHNICAL DATA	5
2.1	Operating and storage conditions	5
2.2	Performance	5
2.3	Mechanical data	6
2.4	Lubrication data	6
2.5	Electrical data	6
3	INSTALLATION	11
3.1	Safety	11
3.2	System design	12
3.3	Unpack and inspect	12
3.4	Locate the pump	13
3.5	Fill the pump with oil	13
3.6	Electrical installation: single-phase motors	14
3.6.1	Introduction	14
3.6.2	Standard single-phase motors	15
3.6.3	Amphenol version single-phase motors	15
3.6.4	110/200-240 V 50 Hz or 115-120/200-230 V 60 Hz single-phase motors	15
3.7	Electrical installation: three-phase motors	19
3.7.1	Connect the electrical supply to the motor	19
3.7.2	Check the direction of rotation	20
3.8	Connect the pump inlet	20
3.9	Connect the pump outlet	22
3.10	Gas-ballast inlet connection	22
3.11	Leak test the system	22
4	OPERATION	23
4.1	ATEX directive implications	23
4.1.1	Introduction	23
4.1.2	Flammable/pyrophoric materials	23
4.1.3	Gas purges	24
4.2	Gas-ballast control	24
4.3	Start-up	25
4.4	To achieve ultimate vacuum	25
4.5	To pump condensable vapours	26
4.6	To decontaminate the oil	26
4.7	Unattended operation	26
4.8	Shut-down	27

E1M18 and E2M18 Rotary Vacuum Pumps

Section		Page
5	MAINTENANCE	29
5.1	Safety information	29
5.2	Maintenance plan	29
5.3	Check the oil-level	30
5.4	Replace the oil	30
5.5	Inspect and clean the inlet-filter	31
5.6	Clean the gas-ballast filter	32
5.7	Clean the motor fan-cover and enclosure	33
5.8	Clean and overhaul the pump	33
5.9	Fit new blades	33
5.10	Test the motor condition	33
5.11	Fault finding	33
5.11.1	Introduction	33
5.11.2	The pump has failed to start	33
5.11.3	The pump fails to achieve specified performance (failure to reach ultimate vacuum)	34
5.11.4	The pump is noisy	34
5.11.5	The pump surface temperature is above 100 °C	34
5.11.6	The vacuum is not maintained after the pump is switched off	35
5.11.7	The pumping speed is poor	35
5.11.8	There is an external oil leak	35
6	STORAGE AND DISPOSAL	37
6.1	Storage	37
6.2	Disposal	37
7	SERVICE, SPARES AND ACCESSORIES	39
7.1	Introduction	39
7.2	Service	39
7.3	Spares	39
7.4	Accessories	40
7.4.1	Introduction	40
7.4.2	Inlet Catchpot	40
7.4.3	Inlet Dust Filter	40
7.4.4	Inlet Desiccant Trap	40
7.4.5	Inlet Chemical Trap	40
7.4.6	Outlet Mist Filter	40
7.4.7	Solenoid Operated Pipeline Valve	42
7.4.8	Foreline Trap	42
7.4.9	Vibration Isolators	42
7.4.10	Oil Drain Extension	42
7.4.11	Pump Inlet Adaptor	42
7.4.12	Flexible Bellows	42
7.4.13	Pump Outlet Adaptor	42
7.4.14	Gas Ballast Banjo/Elbow Assembly	42
7.4.15	Gas Ballast Valve	42

ILLUSTRATIONS

Figure		Page
1	The E1M18/E2M18 pump	3
2	Dimensions (mm): key	8
3	Electrical supply connection: single-phase motors: 220-240 V 50 Hz and 230-240 V 60 Hz	16
4	Electrical supply connection: single-phase motors: 100 V 50 Hz, 100-105 V 60 Hz and 115 V 60 Hz	16
5	Electrical supply connection, single-phase motors: 200 V 50 Hz, 200-210 V 60 Hz and 230 V 60 Hz	17
6	Electrical supply connection, single-phase motors with Amphenol connector: 200-240 V 50 Hz and 230-240 V 60 Hz	17
7	Motor voltage selection: single-phase motors, 110/200-240 V 50 Hz and 115-120/200-240 V 60 Hz	18
8	Electrical supply connection, three-phase motors: 200-220 V 50 Hz and 200-230 V 60 Hz	21
9	Electrical supply connection, three-phase motors: 380-415 V 50 Hz and 460 V 60 Hz	21
10	Remove/replace the inlet filter	31
11	Remove/replace the gas-ballast filter	32
12	Accessories	41

TABLES

Table		Page
1	Operating and storage conditions	5
2	Performance data	5
3	Mechanical data	6
4	Lubrication data	6
5	Electrical data: three-phase motors	7
6	Electrical data: single-phase motors	7
7	Checklist of items	12
8	Motor connection details	14
9	Maintenance plan	30
10	Spares Item Numbers	39
11	Accessory Item Numbers	40

Associated publications

Publication title	Publication Number
Vacuum pump and vacuum system safety	P300-20-000
Vibration isolators	A248-01-880
EMF3, EMF10 and EMF20 oil mist filters	A462-26-880

1 INTRODUCTION

1.1 Scope and definitions

This manual provides installation, operation and maintenance instructions for the BOC Edwards E1M18 and E2M18 rotary vacuum pumps. You must use the pump as specified in this manual.

Read this manual before you install and operate the pump. Important safety information is highlighted as WARNING and CAUTION instructions; you must obey these instructions. The use of WARNINGS and CAUTIONS is defined below.

	WARNING Warnings are given where failure to observe the instruction could result in injury or death to people.
---	--

CAUTION Cautions are given where failure to observe the instruction could result in damage to the equipment, associated equipment and process.
--

The units used throughout this manual conform to the SI international system of units of measurement.

The following warning labels are on the pump:



Warning – refer to accompanying documentation.



Warning – risk of electric shock.



Warning – hot surfaces.

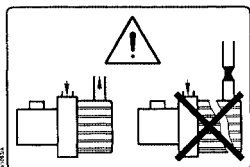

Warning - do not block the pump outlet.

1.2 ATEX directive implications



- This equipment is designed to meet the requirements of Group II Category 3 equipment in accordance with Directive 94/9/EC of the European Parliament and the Council of 23rd March 1994 on the approximation of the laws of the Member States concerning equipment and protective systems intended for use in potentially explosive atmospheres. (The ATEX Directive)

The ATEX Category 3 applies in respect of potential ignition sources internal to the equipment. An ATEX Category has not been assigned in respect of potential ignition sources on the outside of the equipment as the equipment has not been designed for use where there is an external potentially explosive atmosphere.

There is no potential source of ignition within the pump during normal operation but there may be potential sources of ignition under conditions of predictable and rare malfunction as defined in the Directive. Accordingly, although the pump is designed to pump flammable materials and mixtures, operating procedures should ensure that under all normal and reasonably predictable conditions, these materials and mixtures are not within explosive limits. Category 3 is considered appropriate for the avoidance of ignition in the case of a rare malfunction which allows flammable materials or mixtures to pass through the pump while within their explosive limits.

- When flammable or pyrophoric materials are present within the equipment you must:
 - Not allow air to enter the equipment.
 - Ensure that the system is leak tight.
- For further information, please contact BOC Edwards: refer to the Addresses page at the end of this manual for details of your nearest BOC Edwards company.

E1M18 and E2M18 Rotary Vacuum Pumps

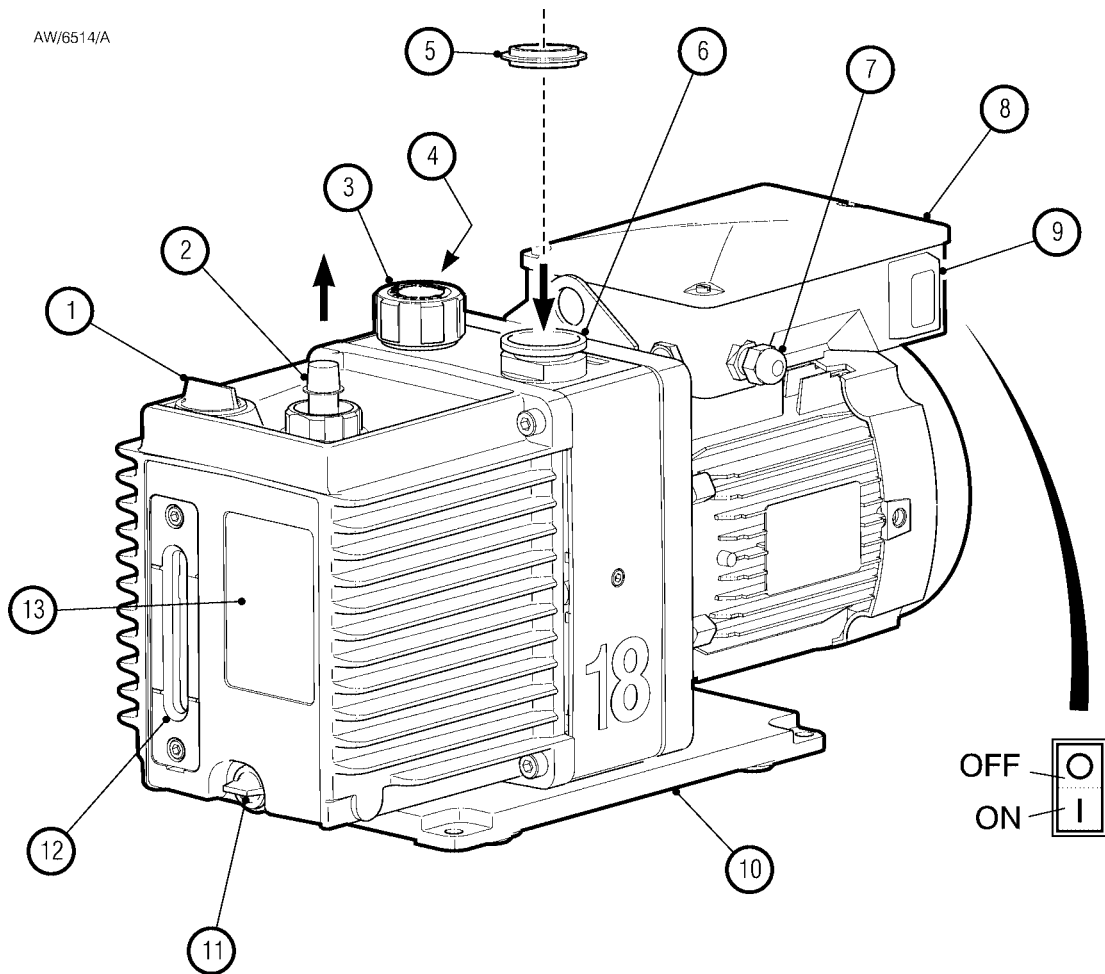

- | | |
|--|------------------------------------|
| 1. Oil filler | 8. Motor terminal box |
| 2. Outlet nozzle | 9. On/Off switch |
| 3. Gas-ballast control | 10. Baseplate |
| 4. Gas-ballast inlet | 11. Oil drain-plug (gravity drain) |
| 5. Centring-ring and 'O' ring (supplied) | 12. Oil sight-glass |
| 6. Inlet-port (adaptor flange) | 13. Pump identification label |
| 7. Cable-gland/Amphenol connector position | |

Notes: A pump with a single-phase motor is shown in this figure.

The motor shown in this figure is not representative of the motor used on the E1/E2M18 pumps with Item Numbers A343-17-984 and A363-17-984. On these pumps, items 7 and 9 are transposed, with Item 7 being an IEC60320 16-20 Amp socket.

Figure 1 – The E1M18/E2M18 pump

1.3 Description

The BOC Edwards E1M18 and E2M18 pumps are shown in Figure 1. Refer to Figure 1 for item numbers in brackets in the following descriptions.

The E1M18 and E2M18 pumps are direct drive, sliding vane pumps. The E1M18 is a single-stage pump, and the E2M18 is a two-stage pump. The pump is oil-sealed and designed for reliable, long-term operation in both laboratory and industrial environments. The pump is a free-standing unit. The drive is provided through a flexible coupling by a single-phase or three-phase (four pole) motor.

The motors are totally enclosed and are cooled by the motor-cooling fan which directs air along the motor fins.

The single-phase motors have a thermal overload device. When the motor is too hot, the thermal overload device switches off the pump. The thermal overload device has an automatic reset; when the motor cools down, the device resets and the motor will restart. The single phase motors have an on/off switch.

An oil pressure system lubricates the pump shaft bearing surfaces and rotor sealing faces. The pump has an oil distribution valve which prevents discharge of oil to the pump interior (suckback) after the pump stops. The pumping chambers are air-tight, so this arrangement prevents air suckback unless the gas-ballast valve is open. For protection in this case, refer to Section 1.4.

You can inspect the level and condition of oil in the oil box reservoir through the oil sight-glass (12). An oil filler-plug (1) is fitted to the top of the oil box. The pump has an oil drain-plug (11) to allow gravity oil drain.

The pump has an inlet-port (6), outlet nozzle (2) and gas-ballast control (3). The pump is mounted on an aluminium alloy baseplate (10) on rubber pads. Details of suitable vibration isolators and other recommended accessories are given in Section 7.4.

1.4 Gas-ballast

When you use the pump with high vapour throughputs, you should use the gas-ballast facility to prevent condensation of the vapours inside the pump. The condensates will contaminate the oil, will cause performance to deteriorate and may cause corrosion of the pump mechanism.

Air (or an inert gas) can be introduced into the pump mechanism through the gas-ballast control (Figure 1, item 3).

The gas-ballast control is a multi-turn valve:

- From the closed position, the first two turns of the gas-ballast control provide an additional oil-feed to the pump mechanism, but do not introduce gas-ballast into the pump. The additional oil-feed improves the lubrication and sealing of the pump mechanism.
- With further turns of the gas-ballast control, the gas-ballast flow into the pump increases from zero flow, until the valve is fully open.

2 TECHNICAL DATA

2.1 Operating and storage conditions

Note: To comply with CSA standards, the pump must be installed and used indoors, and within the operating conditions specified in Table 1 below.

Ambient temperature range (operation)	13 to 40 °C
Ambient temperature range (storage)	-30 to 70 °C
Normal surface temperature of the pump-body *	45 to 65 °C
Maximum humidity (operation)	90% RH
Maximum altitude (operation)	2000 m
Pollution degree	2
Installation category	II
Noise level at 1 metre	57 dB(A) (at 50 Hz)

* At ultimate vacuum, with ambient temperature of 20 °C.

Table 1 – Operating and storage conditions

2.2 Performance

Note: Where total pressures are shown in Table 2 below, measurements were taken using an untrapped total pressure capacitance diaphragm gauge on a header, as specified by Pneurop standards.

	E2M28	E2M30
Maximum displacement		
50 Hz electrical supply	20.5 m ³ h ⁻¹	20.5 m ³ h ⁻¹
60 Hz electrical supply	25.0 m ³ h ⁻¹	25.0 m ³ h ⁻¹
Maximum pumping speed - Pneurop		
50 Hz electrical supply	17.0 m ³ h ⁻¹	17.0 m ³ h ⁻¹
60 Hz electrical supply	20.4 m ³ h ⁻¹	20.4 m ³ h ⁻¹
Motor rotational speed		
50 Hz electrical supply	1440 r min ⁻¹	1440 r min ⁻¹
60 Hz electrical supply	1720 r min ⁻¹	1720 r min ⁻¹
Ultimate vacuum		
without gas-ballast (partial pressure)	2 × 10 ⁻² mbar 2 Pa	1 × 10 ⁻⁴ mbar 1 × 10 ⁻² Pa
without gas-ballast (total pressure)	3 × 10 ⁻² mbar 3 Pa	1 × 10 ⁻³ mbar 1 × 10 ⁻¹ Pa
with full gas-ballast (partial pressure)	6.5 × 10 ⁻¹ mbar 6.5 × 10 ¹ Pa	5 × 10 ⁻³ mbar 5 × 10 ⁻¹ Pa
Maximum water vapour inlet pressure	50 mbar 5 × 10 ³ Pa	20 mbar 2 × 10 ³ Pa
Maximum water vapour pumping rate	0.65 kg h ⁻¹	0.3 kg h ⁻¹
Maximum permitted outlet pressure (for full pump throughput)	0.5 bar gauge 1.5 bar absolute 1.5 × 10 ⁵ Pa	0.5 bar gauge 1.5 bar absolute 1.5 × 10 ⁵ Pa

Table 2 – Performance data

E1M18 and E2M18 Rotary Vacuum Pumps

2.3 Mechanical data

Approximate pump mass	38 kg (E1M18), 41 kg (E2M18)
Dimensions	See Figure 2
Degree of protection	
Single-phase motors	IP44
Three-phase motors	IP54
Pump inlet port	NW25 (the flange can be removed from the 1 inch BSP threaded hole)
Pump outlet port	15 mm external diameter nozzle (the nozzle can be removed from the $\frac{3}{4}$ inch BSP threaded hole)

Table 3 – Mechanical data

2.4 Lubrication data

Note: A BOC Edwards Material Safety Data Sheet for the oil specified below is available on request.

Recommended oil *	Ultragrade 19
Maximum oil capacity	
E1M18	1.4 litres
E2M18	1.05 litres

* To operate the pump when the ambient temperature is outside the range specified in Section 2.1, or to optimise pump performance when you process condensable vapours, you may need a different oil.

Table 4 – Lubrication data

2.5 Electrical data

Refer to Tables 5 and 6. The motor start-up current is drawn for less than one second, so you must use slow-blow fuses to prevent unnecessary fuse failure when the pump starts. Fuses should be to EN60269 Section 2.2. For conformance with CSA standards only CSA certified fuses are to be used. If you use the pump at temperatures lower than 13 °C, the start-up current will be drawn for longer; this may cause the motor thermal overload device to open.

E1M18 and E2M18 Rotary Vacuum Pumps

Pump Item Number	Voltage (V)	Frequency (Hz)	Full load current (A)	Start current (A)	Maximum fuse rating (A)
A343-10-940	200-220	50	3.3	16.1	10
	380-415	50	1.9	10.2	6
	200-230	60	2.3	15.9	10
	460	60	1.6	10.6	6
A363-10-940	200-220	50	3.3	16.1	10
	380-415	50	1.9	10.2	6
	200-230	60	3.4	15.9	10
	460	60	1.6	10.6	6
Motor output rating (continuous)					
50 Hz operation		0.65 kW			
60 Hz operation		0.75 kW			

Table 5 – Electrical data: three-phase motors

Pump Item Number	Voltage (V)	Frequency (Hz)	Full load current (A)	Start current (A)	Maximum fuse rating (A)
A363-15-903, A343-16-903, A343-15-903	220-240	50	4.6	33	15
	230-240	60	5.0	33	15
A343-15-981, A363-15-981	115	60	11.0	70	40
	230	60	5.5	35	20
A343-15-904, A363-15-904	100	50	12.0	88	30
	100-105	60	11.0	88	30
	200	50	6.0	44	15
	200-210	60	5.5	44	15
A343-17-984, A363-17-984	110	50	11.0	42	30
	115-120	60	10.0	38	25
	200-240	50	5.5	32	15
	200-230	60	5.0	31	15
A343-15-912, A363-15-912	220-240	50	5.0	25	13
A343-15-920, A363-15-920	220	50	5.5	35	15
	220	60	5.0	35	15
Motor output rating (continuous)					
50 Hz operation		0.55 kW or 0.65 kW			
60 Hz operation		0.75 kW			

Table 6 – Electrical data: single-phase motors

E1M18 and E2M18 Rotary Vacuum Pumps

Pump Item Number	Hz	Dimension (mm)			
		A	B	C	D
Single-phase motors					
A343-15-912	50	518	-	241	162
A363-15-912	50	520			
A343-15-920, A363-15-920	50	474	-	241	162
	60	520	-	241	162
A343-15-981	60	474	518	241	162
A363-15-981	60	520	564	241	162
A343-15-904	50/60	474	518	241	162
A363-15-904	50/60	520	564	241	162
A363-15-903, A363-17-984	50/60	550	-	251	183
A343-16-903, A343-15-903, A343-17-984	50/60	504	-	251	183
Three-phase motors					
A343-10-940	50/60	474			162
A363-10-940	50/60	520			162

1. Top view of pump with single-phase motor
2. Side view of pump with single-phase motor
3. Side view of pump with three-phase motor
4. Front view of pump with single-phase motor

Figure 2 – Dimensions (mm): key

E1M18 and E2M18 Rotary Vacuum Pumps

AW/6515/B

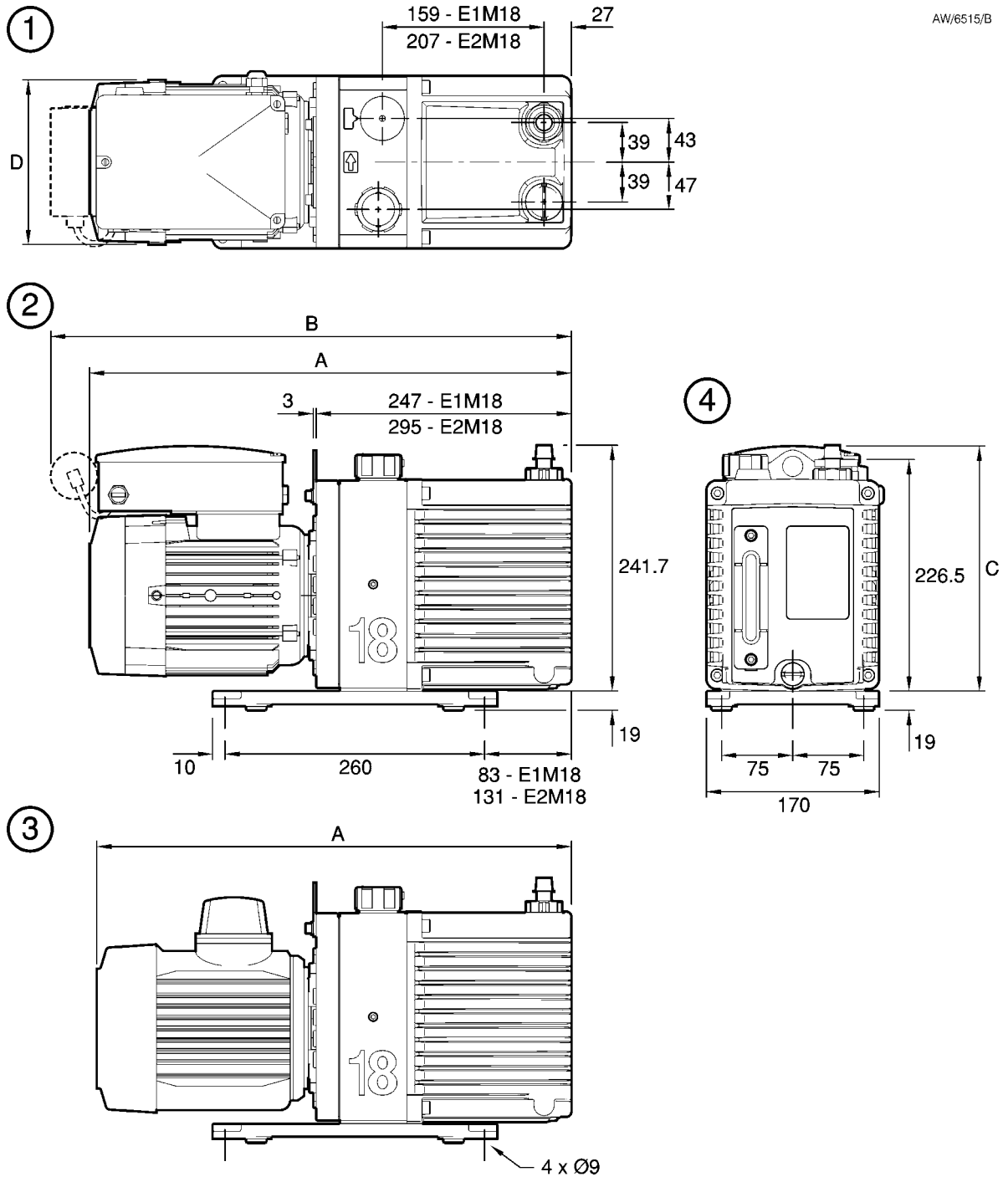

Figure 2 – Dimensions (mm)

3 INSTALLATION

3.1 Safety



WARNING

If you use a hydrocarbon oil in this pump, you must not use the pump to process oxygen in concentrations greater than 25% in volume. If you do, there is a risk of fire or explosion in the oil-box of the pump.



WARNING

You must not use the E1M18 or E2M18 pump to pump hazardous substances.



WARNING

Obey the safety instructions listed below and take note of appropriate precautions. If you do not, you can cause injury to people and damage to equipment.

- A suitably trained and supervised technician must install the pump.
- Wear the appropriate safety-clothing when you come into contact with contaminated components.
- Vent and purge your vacuum system before you start installation work.
- Ensure that the installation technician is familiar with the safety procedures which relate to the pump-oil and the products processed by the pumping system. Take suitable precautions to avoid the inhalation of oil mist and excessive skin contact with pump -oil, as prolonged exposure can be harmful.
- Disconnect the other components in the pumping system from the electrical supply so that they cannot be operated accidentally.
- Safely route any electrical supply cables so that they cannot accidentally trip people.
- You must ensure that the E1M18 or E2M18 pump is suitable for your application. If you have any doubts as to the suitability of the pump for your application, refer to the BOC Edwards guidelines on vacuum pump and vacuum system safety (see the Associated Publication at the end of the contents list at the front of this manual).

3.2 System design

Consider the following points when you design your pumping system:

- Use a suitable inlet-valve to isolate the pump from your vacuum system if you need to allow the pump to warm up before you pump condensable vapours, or if you need to maintain vacuum when the pump is switched off.
- Avoid high levels of heat input to the pump from the process gases, otherwise the pump may overheat and seize, and cause the motor thermal overload device to open.
- If you use the pump in a high ambient temperature and have a high gas throughput, the temperature of the pump-body may exceed 70 °C and you must fit suitable guards to prevent contact with hot surfaces.
- Make sure that the exhaust pipeline cannot become blocked. If you have an outlet-isolation valve, make sure that you cannot operate the pump with the valve closed.
- Provide for a purge of inert gas when you shut down the pumping system, to dilute dangerous gases to safe concentrations. A suitable gas-ballast control valve for introduction of purge gas into the pump is available as an accessory (see Section 7.4.15).

3.3 Unpack and inspect

1. Remove all packing materials and protective covers and check the pump. If the pump is damaged, notify your supplier and the carrier in writing within three days; state the Item Number of the pump together with your order number and your supplier's invoice number. Retain all packing materials for inspection. Do not use the pump if it is damaged.
2. Check that your package contains the items listed in Table 7. If any of these items are missing, notify your supplier within 3 days.

If the pump is not to be used immediately, replace the protective covers. Store the pump in suitable conditions, as described in Section 6.1.

Quantity	Description	Check (✓)
1	E1M18 or E2M18 rotary vacuum pump	<input type="checkbox"/>
(1)	Fitting pack containing the following:	
1	NW25 centring-ring	<input type="checkbox"/>
1	'O' ring for centring-ring	<input type="checkbox"/>
1	Receptacle connectors *	<input type="checkbox"/>

* Various sizes: supplied with single-phase motors except for pumps with Item Numbers A343-16-903, A343-17-984 and A363-17-984.

Table 7 – Checklist of items

3.4 Locate the pump



WARNING

Use suitable lifting equipment to move the pump. If you do not, you can injure yourself or damage the pump. Refer to Section 2.3 for the mass of the pump.

The pump can be either free-standing on its baseplate, or be fixed by bolts through the four fixing holes in the baseplate, or be used with vibration isolators. For the locations of the fixing holes in the baseplate, refer to Figure 2.

Provide a firm, level platform for the pump. Locate the pump so that the oil-level sight-glass is visible and the oil filler-plug, oil drain-plugs and gas -ballast control are accessible.

If your pump will be located inside an enclosure, make sure that there is adequate ventilation at both ends of the pump, so that the ambient temperature around the pump does not exceed 40 °C. There must be a minimum space of 25 mm between the pump and the enclosure walls.

3.5 Fill the pump with oil

Fill the pump with oil as described below. Refer to Figure 1 for the item numbers in brackets.

1. Remove the oil filler-plug (1).
2. Pour oil into the pump until the oil-level reaches the MAX mark on the bezel at the top of the oil sight-glass (12). If the oil-level goes above the MAX mark, remove the oil drain-plug (11) and drain the excess oil from the pump.
3. After a few minutes, recheck the oil-level. If the oil-level is now below the MAX mark, pour more oil into the pump.
4. Refit the oil filler-plug. Tighten the plug firmly by hand. Do not overtighten.

3.6 Electrical installation: single-phase motors

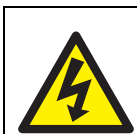

WARNING

Ensure that the electrical installation of the pump conforms with your local and national safety requirements. It must be connected to a suitably fused and protected electrical supply and a suitable earth (ground) point.

CAUTION

Ensure that the motor is correctly configured for your electrical supply voltage and frequency. If you do not, you can damage the motor.

3.6.1 Introduction

Note: The pump will restart automatically when the electrical supply is restored after an interruption and when the pump cools after it has overheated. If you do not want the pump to restart automatically, use electrical control equipment which must be reset manually.

Ensure that your electrical supply voltage corresponds with the voltage specified on the motor data plate.

Table 5 gives the recommended fuse rating, and Table 8 specifies the Figure which identifies the correct electrical supply connection details.

The diameter of the outer sheath of the electrical supply cable must be within the range 7 to 10.5 mm. The cable must conform in size and colour coding with your local and national electrical installation regulations. The temperature rating of the cable must be 70 °C or greater.

Pump Item Number	Voltage (V)	Frequency (Hz)	Connection details: refer to Figure
A343-15-912, A363-15-912, A343-15-920, A363-15-920, A363-15-903, A343-15-903	(all)	50/60	3
A343-15-981, A363-15-981	115	60	4
	230	60	5
A343-15-904, A363-15-904	100	50	4
	100-105	60	4
	200	50	5
	200-210	60	5
A343-16-903	(all)	50/60	6
A343-17-984, A363-17-984	(all)	50/60	7

Table 8 – Motor connection details

3.6.2 Standard single-phase motors

1. Remove the cover from the motor terminal box (Figure 1, item 8).
2. Remove the cable-gland from the inside of the terminal-box and fit the cable-gland to the cable leadthrough hole in the side of the terminal-box.
3. Pass the electrical supply cable through the gland.
4. Remove the receptacle connectors from the fitting pack.
5. Fit a ring connector to the earth (ground) wire.
6. Select the correct size of receptacle connectors for your cable wires:
 - Use the red connectors for wire sizes 0.75 to 1.5 mm².
 - Use the blue connectors for wire sizes 1.5 to 2.5 mm².
7. Attach the appropriate connector to the live and neutral wires.
8. Connect the electrical supply cable to the appropriate terminals as shown in Figures 3 to 5. You must tighten the earth (ground) terminal connection to a torque of 2.13 to 2.87 Nm.
9. Tighten the dome shaped nut on the cable-gland until the outer sheath of the cable is firmly gripped. Do not overtighten.
10. Check that the cable connections are correct, then refit the cover on the motor terminal-box.

3.6.3 Amphenol version single-phase motors

When you select the mating half of the amphenol connector, please ensure that it is compatible.

For conformance with CSA standards, only CSA certified connectors are to be used; the protective earth (ground) connection is required to make first and break last with respect to the other connections.

Connect the electrical supply cable to the appropriate pins as shown in Figure 6.

3.6.4 110/200-240 V 50 Hz or 115-120/200-230 V 60 Hz single-phase motors

The motor is designed for a single-phase electrical supply and is suitable for 50 Hz and 60 Hz operation. The motor can be manually switched between nominal supply voltages of 110-120 V and 200-240 V.

Use the following procedure to check that the voltage selector switch is correctly positioned for your electrical supply voltage:

1. Refer to Figure 7. Undo the three screws securing the terminal box cover (1) and remove the cover.
2. Check the position of the voltage selector switch (6). If the switch is in the correct position, continue at Step 3. If the voltage selector switch (6) is in the wrong position, press the switch to select the alternative position.
3. Refit the terminal box cover and secure with the three screws.

When you select the mating half of the connector, please ensure that it is compatible (IEC60320 C19 female). For compliance with CSA standards, only CSA certified connectors are to be used.

E1M18 and E2M18 Rotary Vacuum Pumps

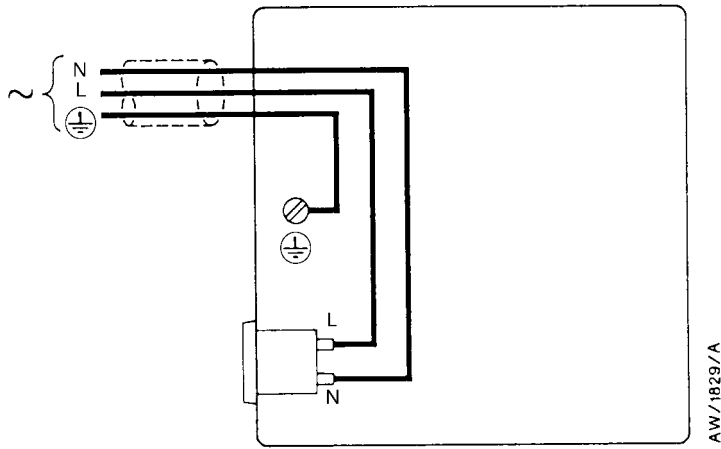
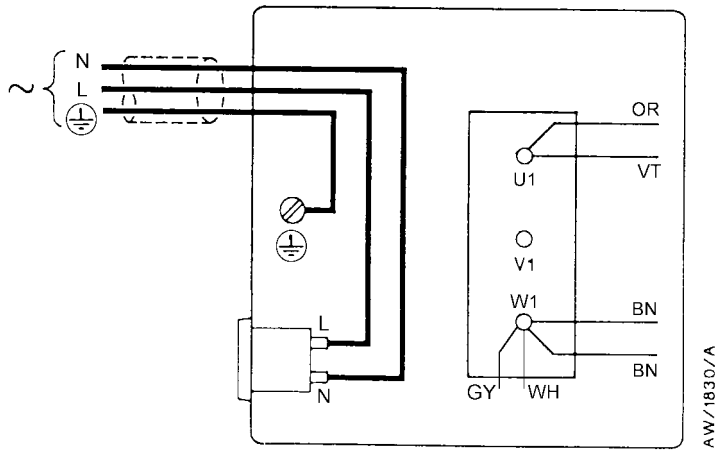

Figure 3 – Electrical supply connection: single-phase motors: 220-240 V 50 Hz and 230-240 V 60 Hz



Wire colour codes:

BN	Brown	VT	Violet
GY	Grey	WH	White
OR	Orange		

Figure 4 – Electrical supply connection: single-phase motors: 100 V 50 Hz, 100-105 V 60 Hz and 115 V 60 Hz

E1M18 and E2M18 Rotary Vacuum Pumps

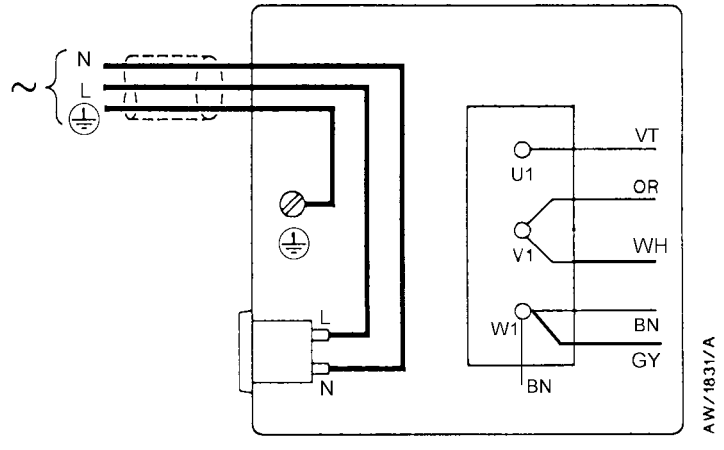

Wire colour codes:

BN	Brown	VT	Violet
GY	Grey	WH	White
OR	Orange		

Figure 5 – Electrical supply connection, single-phase motors: 200 V 50 Hz, 200-210 V 60 Hz and 230 V 60 Hz

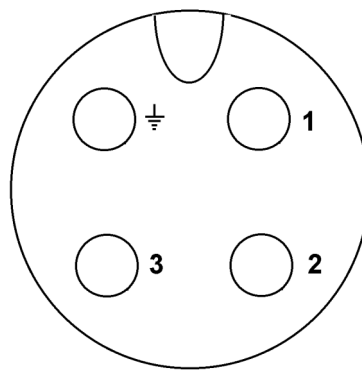

Pin codes:

1	Live
2	Neutral
3	Not used
⊥	Earth (ground)

Figure 6 – Electrical supply connection, single-phase motors with Amphenol connector:
220-240 V 50 Hz and 230-240 V 60 Hz

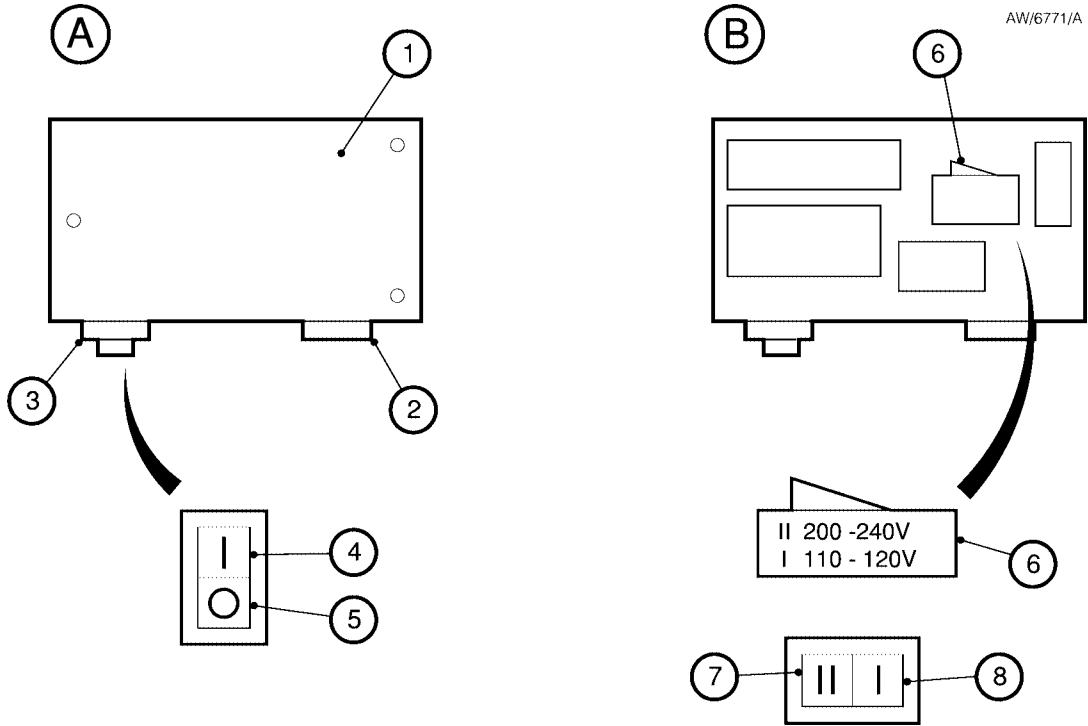

- | | |
|---|--|
| <p>A Top view of motor</p> <p>B Internal view of top of motor</p> | <ol style="list-style-type: none"> 1. Terminal box cover 2. Electrical inlet socket 3. On/Off switch 4. Position 'I' (on) 5. Position 'O' (off) 6. Voltage selector switch 7. Position 'II' (high voltage setting 200 – 240 V) 8. Position 'I' (low voltage setting 110 – 120 V) |
|---|--|

Figure 7 – Motor voltage selection: single-phase motors, 110/200-240 V 50 Hz and 115-120/200-240 V 60 Hz

3.7 Electrical installation: three-phase motors

3.7.1 Connect the electrical supply to the motor

	<p style="text-align: center;">WARNING</p> <p>Ensure that the electrical installation of the pump conforms with your local and national safety requirements. It must be connected to a suitably fused and protected electrical supply and a suitable earth (ground) point.</p>
---	---

<p style="text-align: center;">CAUTION</p> <p>Ensure that the motor is correctly configured for your electrical supply voltage and frequency. If you do not, you can damage the motor.</p>

Note: The pump will restart automatically when the electrical supply is restored after an interruption. If you do not want the pump to restart automatically, use electrical control equipment which must be reset manually.

We recommend that you connect the electrical supply to the motor through a starter or circuit breaker which has thermal over-current protection which can be adjusted to suit the full load current ratings shown in Table 5. The fuse ratings in Table 5 are provided for guidance only. The supplier of your thermal overcurrent protection device may specify different values to ensure correct operation of the fuse and the overcurrent protection device. Ensure that the fuse you use is suitable for the starting currents given in Table 5. Refer to Figure 8 or 9 as appropriate for the correct electrical supply connection diagram for your motor.

The diameter of the outer sheath of the electrical cable must be in the range 10-14 mm. The cable must conform in size and colour coding with your local and national electrical installation regulations. The temperature rating of the cable must be 70 °C or greater.

1. Remove the cover from the motor terminal-box.
2. Remove the cable-gland from the inside of the terminal-box and fit the cable-gland to the cable leadthrough hole in the side of the terminal-box.
3. Refer to the electrical supply connection diagram for your pump, (Figure 8 or 9). Make sure that the metal links are connected as shown; if they are not, move the links to the positions shown.
4. Pass the electrical supply cable through the cable-gland and connect to the appropriate terminals, as shown in Figures 8 and 9. You must tighten the earth (ground) terminal connection to a torque of 2.13 to 2.87 Nm.
5. Tighten the cable gland until the outer sheath of the cable is firmly gripped. Do not overtighten.
6. Ensure that the gasket seal for the terminal box cover is correctly positioned, then refit the cover to the terminal-box and secure with the screws.

3.7.2 Check the direction of rotation

CAUTION

Ensure that the motor rotates in the correct direction. If it does not, the pump and your vacuum system can become pressurized when you operate the pump.

1. With the pump inlet still unconnected, watch the motor cooling-fan through the motor fan-cover, switch-on the electrical supply to the motor for a few seconds, then switch off the electrical supply again.
2. Check that the motor cooling-fan rotates in the correct direction shown by the arrow on the motor mounting plate. If the direction of rotation is incorrect:
 - Switch off the electrical supply immediately.
 - Isolate the pump from the electrical supply.
 - Remove the terminal-box cover and swap wires L1 and L3: see Figures 8 and 9.
 - Refit the cover to the terminal-box.

3.8 Connect the pump inlet

Take note of the following information when you connect the pump to your vacuum system. Refer to Section 7.4 for details of the accessories mentioned below.

- For optimum pumping speeds, ensure that the pipeline connected to the inlet-port is as short as possible and has an internal diameter not less than the inlet-port diameter.
- Support the vacuum pipelines to prevent loading of the coupling-joints.
- If necessary, incorporate flexible bellows in your system pipelines to reduce the transmission of vibration and to prevent loading of coupling-joints. If you use flexible bellows, you must ensure that you use bellows which have a maximum pressure rating which is greater than the highest pressure that can be generated in your system. We recommend that you use BOC Edwards flexible bellows.
- Use a suitable inlet catchpot if you pump condensable vapours or if you use the pump for very dusty applications.
- Ensure that sealing surfaces are clean and scratch-free.

Connect your vacuum system to the inlet-port (Figure 1, item 6). To make this connection, you can:

- Connect to the NW25 flange supplied: use the NW25 centring-ring and 'O' ring supplied.
- Remove the NW25 flange and connect to the 1 inch BSP threaded hole.
- Use an NW25 to 28 mm bore tube adaptor available as an optional accessory, see Section 7.4.11.

E1M18 and E2M18 Rotary Vacuum Pumps

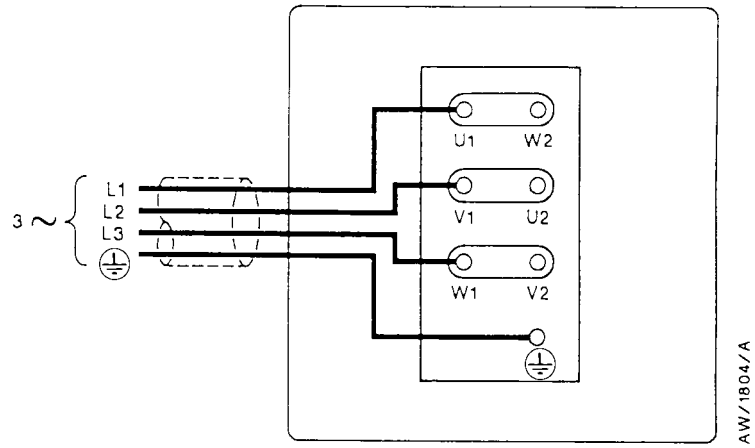

Figure 8 – Electrical supply connection, three-phase motors: 200-220 V 50 Hz and 200-230 V 60 Hz

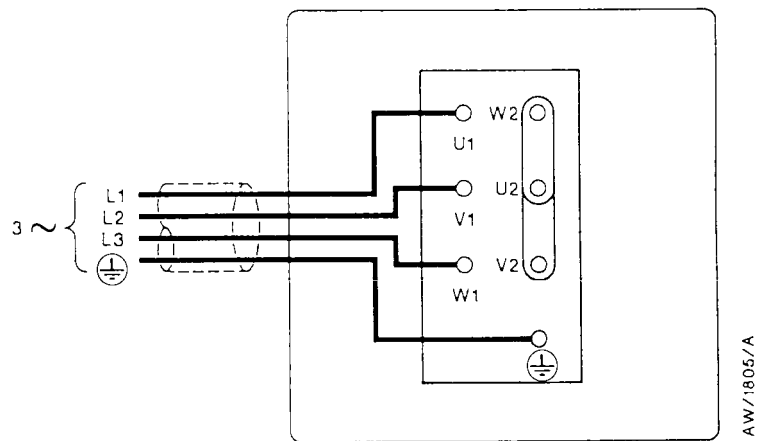

Figure 9 – Electrical supply connection, three-phase motors: 380-415 V 50 Hz and 460 V 60 Hz

3.9 Connect the pump outlet



WARNING

Connect the pump outlet to a suitable treatment plant to prevent the discharge of dangerous gases and vapours to the surrounding atmosphere.



WARNING

Use a catchpot to prevent the drainage of contaminated condensate back into the pump.

The exhaust system must be configured so that the maximum pressure at the pump outlet does not exceed 0.5 bar gauge (1.5 bar absolute, 1.5×10^5 Pa) at full pump throughput.

We recommend that you fit an oil mist filter to the pump outlet in the following circumstances:

- If you use the pump with the gas-ballast control open.
- If you operate the pump with an inlet pressure greater than 10 mbar for extended periods.
- If you frequently pump down from atmospheric pressure.

The mist filter will trap the oil exhausted from the pump: you can reuse the oil if it is not contaminated.

To connect the pump to your outlet accessories or to your exhaust treatment plant, you can:

- Connect 15 mm internal diameter vacuum or plastic hose to the outlet nozzle (Figure 1, item 2).
- Remove the outlet nozzle and connect to the $\frac{3}{4}$ inch BSP threaded hole.
- Remove the outlet nozzle and replace it with an NW25 flange adaptor (available as an optional accessory, see Section 7.4.13) and then connect to the NW25 flange.

3.10 Gas-ballast inlet connection

The position of the gas-ballast inlet is shown in Figure 1 (item 4). The gas-ballast inlet has several filters (shown in Figure 11) to trap any dust and debris if you use air as the gas-ballast supply.

If you want to use a different gas for the gas-ballast supply, or if you want to connect a valve to the gas-ballast inlet:

1. Remove the filters (as described in Section 5.6).
2. Connect your gas supply or valve to the $\frac{1}{4}$ inch BSP threaded hole.

3.11 Leak test the system

Leak-test the system and seal any leaks found after you have installed the pump, to prevent leakage of substances out of the system and leakage of air into the system.

4 OPERATION



WARNING

Do not expose any part of your body to vacuum. If you do, you may be injured.

4.1 ATEX directive implications

4.1.1 Introduction

This equipment is designed to meet the requirements of Group II Category 3 equipment in accordance with Directive 94/9/EC of the European Parliament and the Council of 23rd March 1994 on the approximation of the laws of the Member States concerning equipment and protective systems intended for use in potentially explosive atmospheres. (The ATEX Directive)

The ATEX Category 3 applies in respect of potential ignition sources internal to the equipment. An ATEX Category has not been assigned in respect of potential ignition sources on the outside of the equipment as the equipment has not been designed for use where there is an external potentially explosive atmosphere.

There is no potential source of ignition within the pump during normal operation but there may be potential sources of ignition under conditions of predictable and rare malfunction as defined in the Directive. Accordingly, although the pump is designed to pump flammable materials and mixtures, operating procedures should ensure that under all normal and reasonably predictable conditions, these materials and mixtures are not within explosive limits. Category 3 is considered appropriate for the avoidance of ignition in the case of a rare malfunction which allows flammable materials or mixtures to pass through the pump whilst within their explosive limits.

4.1.2 Flammable/pyrophoric materials



WARNING

You must obey the instructions and take note of the precautions given below, to ensure that pumped gases do not enter their flammable ranges.

When flammable or pyrophoric materials are present within the equipment you must:

- Not allow air to enter the equipment.
- Ensure that the system is leak tight.
- Use an inert gas purge (for example, a nitrogen purge) to dilute any flammable gases or vapours entering the pump inlet, and/or use an inert gas purge to reduce the concentration of flammable gases or vapours in the pump and in the exhaust pipeline to less than one quarter of the gases' published lower explosive limits (LEL).
- Use an inert gas purge into the pump gas ballast connection to prevent the condensation of flammable vapours within the pump mechanism and exhaust pipeline.

4.1.3 Gas purges



WARNING

If you use inert gas purges to dilute dangerous gases to a safe level, ensure that the pump is shut down if an inert gas supply fails.



WARNING

You must obey the instructions and take note of the precautions given below, to ensure that pumped gases do not enter their flammable ranges.

Switch on the inert gas purge to remove air from the pump and the exhaust pipeline before the process starts. Switch off the purge flow at the end of the process only after any remaining flammable gases or vapours have been purged from the pump and exhaust pipeline.

If liquids that produce flammable vapours could be present in the pump foreline, then the inert gas purge to the pump should be left on all the time this liquid is present. Flammable liquids could be present in the foreline as a result of condensation, or may be carried over from the process.

When you calculate the flow rate of inert gas required for dilution, consider the maximum flow rate for the flammable gases/vapours that could occur. For example, if a mass flow controller is used to supply flammable gases to the process, you should assume a flow rate for flammable gases that could arise if the mass flow controller is fully open.

Continually measure the inert gas purge flow rate: if the flow rate falls below that required, you must stop the flow of flammable gases or vapours into the pump.

Note: We recommend that you obtain and read the Vacuum Pump and Vacuum System Safety manual (publication number P300-20-000), available from BOC Edwards or your supplier.

4.2 Gas-ballast control

Use the gas-ballast control (Figure 1, item 3) to change the flow of gas-ballast into the low vacuum stage of the pump, and to provide an additional oil-feed to the pump mechanism.

Use the gas-ballast control closed:

- To achieve ultimate vacuum.
- To pump dry gases.

Turn the gas-ballast control by up to two turns anti-clockwise to introduce an additional oil-feed to the pump mechanism. We recommend that you do this when you pump high throughputs of dry gases.

Turn the gas-ballast control from two to six turns anti-clockwise to increase the gas-ballast from zero flow. Use gas-ballast flow:

- To pump high concentrations of condensable vapour.
- To decontaminate the oil.

When you operate the pump with the gas-ballast control open, there will be an increased rate of oil loss from the pump. Ideally, a mist filter and oil return kit should be used on clean applications.

4.3 Start-up



WARNING

Do not block the pump outlet or allow the outlet pressure to rise above 1.5 bar absolute. If you do, the oil box may fracture and may cause injury to people nearby.

If the oil is contaminated, or if the pump temperature is below 13 °C, or if the electrical supply voltage is more than 10% below the lowest voltage specified for the pump, the pump may operate at a reduced speed for a few minutes. On single-phase pumps, if the pump continues to operate at reduced speed, the motor thermal overload device will open and stop the pump. When the motor has cooled, the thermal overload device will reset automatically and the pump will restart.

1. Check that the pump oil-level is between the MAX and MIN marks on the bezel of the oil-level sight-glass; if it is not, refer to Section 5.3.
2. Turn the gas-ballast control to the required position (refer to Section 4.2).
3. Switch on the electrical supply to the pump.
4. Check that the oil-level in the sight-glass drops slightly (by 3 to 5 mm) after start-up. This shows that the pump has primed with oil.
5. If the pump fails to prime, operate the pump with the inlet open to atmosphere for approximately 30 seconds. Then isolate the inlet and check that the oil-level drops by 3 to 5 mm.
6. If you want to achieve ultimate vacuum, to pump condensable vapours or to decontaminate the pump oil, refer to the procedures in Sections 4.4, 4.5 and 4.6 respectively. Otherwise, open the vacuum system isolation-valve.

4.4 To achieve ultimate vacuum

If the pump does not achieve the performance specified in Section 2.2, make sure that this is not due to your system design before you contact your supplier or BOC Edwards for advice. In particular, the vapour pressure of all materials used in your vacuum system (including pump oil, see below) must be much lower than the specified ultimate vacuum of the pump.

Refer to Section 5.11.3 for a list of possible causes for failure to achieve the specified performance; note however that the most common causes are:

- Your pressure measurement technique or gauge head is unsuitable or the gauge head is faulty.
- You have used an oil other than the recommended oil, and the vapour pressure of the oil is higher than the specified ultimate vacuum of the pump.

Use the following procedure to achieve ultimate vacuum:

1. Isolate the pump from your vacuum system.
2. Turn the gas-ballast control fully anti-clockwise (fully open) and operate the pump for at least 1 hour (or overnight) to thoroughly purge the oil of contaminants.
3. Close the gas-ballast control.
4. Open the vacuum system isolation-valve and pump down to ultimate vacuum.

4.5 To pump condensable vapours

Use gas-ballast (open the gas-ballast control) when there is a high proportion of condensable vapours in the process gases:

1. Close the vacuum system isolation-valve.
2. Turn the gas-ballast control anti-clockwise to fully open and operate the pump for 30 minutes to warm the oil; this will help to prevent vapour condensation in the pump.
3. Open the vacuum system isolation-valve and continue to operate the pump with the gas-ballast control open.

After you have pumped condensable vapours, you can (if necessary) decontaminate the oil; use the procedure in Section 4.6.

4.6 To decontaminate the oil

The oil in the pump should be clear, if the oil is cloudy or discoloured, it is contaminated with process vapours.

1. Look at the condition of the oil in the oil sight-glass (Figure 1, item 12). If the oil is cloudy or discoloured, continue with the procedure at Step 2 below.
2. Close the vacuum system isolation-valve.
3. Turn the gas-ballast control fully anti-clockwise.
4. Operate the pump until the oil is clear.

4.7 Unattended operation

The pump is designed for unattended operation under the normal operating conditions specified in Section 2.1. However, we recommend that you check the pump at a regular interval of not more than 14 days; check the pump more frequently if you pump high volumes of gas or if you operate the pump with the gas-ballast control open.

Single-phase motors are cooled by internal fans. These motors have a thermal overload device. When the motor is too hot, the thermal overload device switches off the pump. The thermal overload device has an automatic reset; when the motor cools down, the device resets and the motor will restart.

When you check the pump, make sure that the pump is not going through a repetitive cycle of thermal overload failures and automatic resets. If necessary reduce the thermal load from the pumped gases, to prevent overheating of the pump.

4.8 Shut-down

Note: If the gas-ballast control is open and the motor is switched off for any reason, the pump drive shaft may rotate in the reverse direction, causing a system pressure rise. To prevent this, use a gas-ballast control valve (refer to Section 7.4.15).

We recommend, as described in the procedure below, that you decontaminate the oil before you shut down the pump; this will prevent damage to the pump by the contaminants in the oil.

1. Refer to Section 4.6 and decontaminate the oil, as required.
2. Close the vacuum system isolation-valve (if not already closed).
3. Close gas-ballast (that is, turn the gas-ballast control clockwise).
4. Switch off the electrical supply to the pump.

5 MAINTENANCE

5.1 Safety information



WARNING

Obey the safety instructions given below and take note of appropriate precautions. If you do not, you can cause injury to people and damage to equipment.

- A suitably trained and supervised technician must maintain the pump.
- Ensure that the maintenance technician is familiar with the safety procedures which relate to the pump-oil and the products processed by the pumping-system.
- Allow the pump to cool to a safe temperature before you start maintenance work.
- Isolate the pump and other components in the pumping system from the electrical supply so that they can not be operated accidentally.
- After maintenance is completed, recheck the pump rotation direction if the electrical supply has been disconnected.
- Do not reuse 'O' rings and seals if they are damaged.
- The pump and its oil will be contaminated with the process chemicals that have been pumped during operation. Ensure that the pump is decontaminated before maintenance and that you take adequate precautions to protect people from the effects of dangerous substances if contamination has occurred.
- Leak-test the system after maintenance work is complete if you have connected or disconnected any vacuum or exhaust joints; seal any leaks found.
- Do not touch or inhale the thermal breakdown products of fluorinated materials which may be present if the pump has been heated to 260 °C and above. These breakdown products are very dangerous. Fluorinated materials in the pump may include oils, greases and seals. The pump may have overheated if it was misused, if it malfunctioned or if it was in a fire. BOC Edwards Material Safety Data sheets for fluorinated materials used in the pump are available on request: contact your supplier or BOC Edwards.

5.2 Maintenance plan

The plan shown in Table 9 details the routine maintenance operations necessary to maintain the pump in normal use. Instructions for each operation are given in the section shown.

More frequent maintenance may be required if the pump is used to process corrosive or abrasive gases and vapours; in these circumstances, we recommend that you replace the pump seals every year. If necessary, adjust the maintenance plan according to your experience.

When you maintain the pump, use BOC Edwards spares and maintenance kits; these contain all of the components necessary to complete maintenance operations successfully. The Item Numbers of the spares and kits are given in Section 7.3.

Examine the condition of any external accessories, filters or traps (if fitted) when you maintain the pump. Refer to the instructions supplied with these accessories for the necessary maintenance procedures.

E1M18 and E2M18 Rotary Vacuum Pumps

Operation	Frequency	Refer to Section
Check the oil level	As required; at least monthly	5.3
Replace the oil	Every 3000 hours of operation	5.4
Inspect and clean the inlet filter	Every oil change	5.5
Clean or replace the gas-ballast filter	Yearly	5.6
Clean the motor fan-cover and enclosure	Yearly	5.7
Clean and overhaul the pump	Every 15000 hours of operation	5.8
Fit new blades	Every 30000 hours of operation	5.9
Test the motor condition	Every 15000 hours of operation	5.10

Table 9 – Maintenance plan

5.3 Check the oil-level

Note: If required, you can check the oil-level while the pump is operating, however you must switch off the pump and isolate the pump and other components in the pumping system from the electrical supply before you pour oil into the pump.

Refer to Figure 1 for the items in brackets.

1. Check that the oil-level in the oil sight-glass (12) is between the MAX and MIN level marks on the bezel of the oil sight-glass.
2. If the oil-level is near to or below the MIN level mark, remove the oil filler-plug (1) and pour more oil into the reservoir until the oil reaches the MAX level mark. If the oil-level goes above the MAX mark, remove the oil drain-plug (11) and drain the excess oil from the pump. Refit the oil drain-plug. Refit the oil filler-plug.
3. If the oil is contaminated, drain and refill the pump with clean oil as described in Section 5.4.

5.4 Replace the oil

Refer to Figure 1 for the items in brackets.

1. Operate the pump for approximately ten minutes to warm the oil, then switch off the pump. (This lowers the viscosity of the oil and allows the oil to be drained from the pump more easily).
2. Isolate the pump from your electrical supply and disconnect it from your vacuum system.
3. Remove the oil filler-plug (1).
4. Place a suitable block under the pump-motor to tilt the pump and place a suitable container under the oil drain-plug (gravity drain) (11). Remove the oil drain-plug and allow the oil to drain into the container.
5. If the oil is dirty or contaminated:
 - Refit the oil drain-plug and pour clean oil into the pump.
 - Reconnect the pump to the electrical supply and operate the pump for about 5 to 10 minutes.
 - Disconnect the pump from the electrical supply, remove the oil drain-plug and allow the oil to drain out of the pump.
 - Repeat this step until the oil reservoir is clean.

E1M18 and E2M18 Rotary Vacuum Pumps

6. Refit the oil drain-plug, remove the block and reconnect the pump to your vacuum system.
7. Fill a suitable container with clean oil and pour the oil into the filler hole until the oil-level reaches the MAX level mark on the bezel of the oil sight-glass (12).
8. Allow a few minutes for the oil to drain into the pump. If necessary, add more oil. Refit the oil filler-plug.

5.5 Inspect and clean the inlet-filter

Refer to Figure 10.

1. Unscrew the inlet adaptor (1) and remove the 'O' ring (2), circlip (3) and inlet-filter (4).
2. Wash the filter in a suitable cleaning solution. Allow the filter to dry.
3. Refit the inlet-filter (4), circlip (3), 'O' ring (2) and inlet adaptor (1).

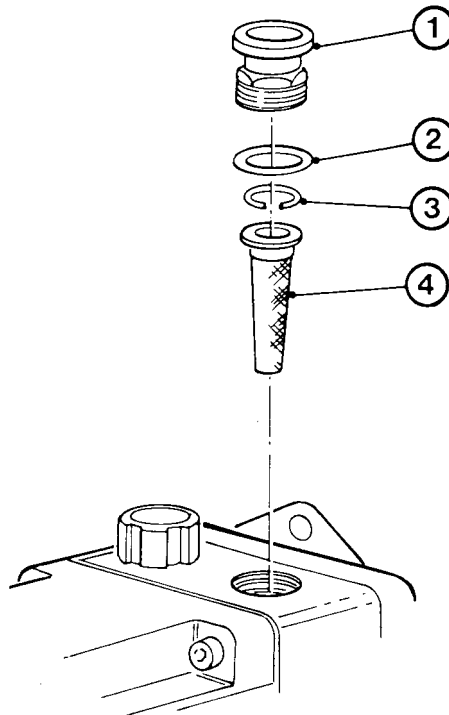

1. Inlet adaptor
2. 'O' ring
3. Circlip
4. Inlet-filter

Figure 10 – Remove/replace the inlet filter

5.6 Clean the gas-ballast filter

Note: You may have removed the gas-ballast filter to connect a gas supply or valve to the gas-ballast inlet.

Refer to Figure 11.

1. Remove the retainer circlip (3).
2. Remove the protective wire mesh (2) and filter elements (1).
3. Wash the wire mesh and filter in a suitable cleaning solution. Allow the wire mesh and filter to dry before replacing them in the pump.
4. Refit the wire mesh (2) and filter element (1) in the adaptor plate housing and retain with the retainer circlip (3).

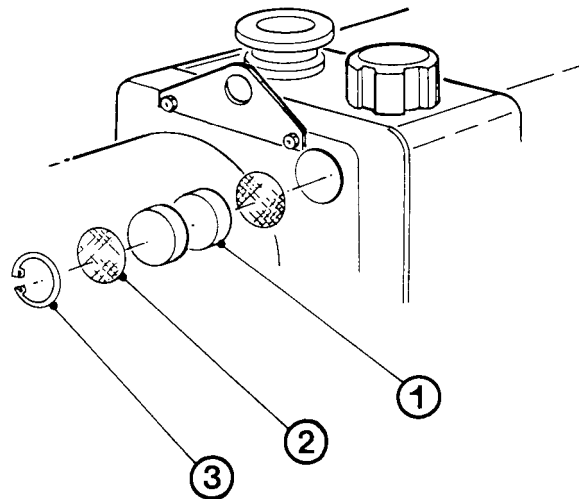

1. Filter element
2. Wire mesh
3. Retainer circlip

Figure 11 – Remove/replace the gas-ballast filter

5.7 Clean the motor fan-cover and enclosure

If the motor fan-cover and enclosure are not kept clean, the air-flow over the motor can be restricted and the pump may overheat.

1. Switch off the pump and disconnect it from the electrical supply.
2. Use a dry cloth and a brush to remove dirt and deposits from the fan-cover and enclosure.

5.8 Clean and overhaul the pump

Clean and overhaul the pump as described in the instructions supplied with the clean and overhaul kit (see Section 7.3).

5.9 Fit new blades

Fit new blades to the pump as described in the instructions supplied with the blade kit (see Section 7.3).

5.10 Test the motor condition

Test the earth (ground) continuity and the insulation resistance of the pump-motor, in accordance with local regulations for periodic testing of electrical equipment. We recommend that:

- The earth (ground) continuity is less than 0.1Ω
- Insulation resistance is greater than $10 M\Omega$

If the motor fails these tests, you must replace the motor.

5.11 Fault finding

5.11.1 Introduction

A list of fault conditions and their possible causes is provided in the following sections to assist you in basic fault-finding. If you are unable to rectify a fault when you use this guide, call your supplier or your nearest BOC Edwards Service Centre for advice.

5.11.2 The pump has failed to start

- The electrical supply fuse has failed.
- The motor is incorrectly wired.
- The operating voltage does not match that of the motor.
- The exhaust filter or exhaust line is blocked.
- The oil temperature is below $13 \text{ }^\circ\text{C}$.
- The oil is too viscous.
- The oil is contaminated.
- The pump is seized after long storage, or has been left to stand after pumping contaminants.
- The motor is faulty.

5.11.3 The pump fail to achieve specified performance (failure to reach ultimate vacuum)

- Your measuring technique or gauge is unsuitable.
- There is a leak in the external vacuum system.
- The gas-ballast control is open.
- The oil level is too low.
- You have filled the pump with the wrong type of oil.
- The oil is contaminated.
- The pump has not primed.
- The vacuum fittings are dirty.
- The inlet-filter is blocked.
- The pump has not warmed up.
- The motor shaft rotates in the wrong direction.

5.11.4 The pump is noisy

- The motor fan-cover is damaged.
- The coupling and fan assembly are poorly adjusted.
- The motor coupling is loose.
- The motor bearings are worn.
- The oil is contaminated with solid particles.
- One of the pump blades is sticking.

5.11.5 The pump surface temperature is above 100 °C

- The ambient temperature is too high.
- The cooling-air supply is insufficient or is too hot.
- The cooling-air supply is blocked.
- The electrical supply voltage is too high.
- The exhaust filter or exhaust line is blocked.
- The oil level is too low.
- The pump is filled with the wrong type of oil.
- The oil is contaminated.
- The process gas is too hot, or the throughput is too high.

5.11.6 The vacuum is not maintained after the pump is switched off

- The gas-ballast control is open.
- 'O' ring(s) are damaged or missing.
- The shaft seals have deteriorated.

5.11.7 The pumping speed is poor

- The connecting pipelines are too small in diameter.
- The connecting pipelines are too long.
- The inlet-filter is blocked.

5.11.8 There is an external oil leak

- The oil pump shaft seal is worn or damaged.
- The oil box gasket has deteriorated.
- There is an oil leak from gas-ballast control.
- There is an oil-leak from the drain-plug.

6 STORAGE AND DISPOSAL

6.1 Storage

CAUTION

Observe the storage temperature limits stated in Section 2.1. Storage below these limits will permanently damage the pump seals.

Note: If you will store a new pump in conditions of high humidity, remove the pump from its cardboard packaging box; dispose of the box (refer to Section 6.2).

Use the following procedure to store the pump:

1. Shut-down the pump as described in Section 4.8.
2. Disconnect the pump from the electrical supply.
3. Purge your vacuum system and the pump with dry nitrogen and disconnect the pump from your vacuum system.
4. Replace the oil as described in Section 5.4.
5. Place and secure protective covers over the inlet and outlet-ports.
6. Store the pump in cool, dry conditions until required for use.

When required, prepare and install the pump as described in Section 3. If the pump has been stored for more than a year, you must clean and overhaul the pump before you install it, as described in the instructions supplied with the clean and overhaul kit.

6.2 Disposal

Dispose of the pump, the oil and any components removed from the pump safely in accordance with all local and national safety and environmental requirements.

Take particular care with the following:

- Components which have come into contact with the pump fluid.
- Components which have been contaminated with dangerous process substances.

Do not incinerate fluoroelastomer seals and 'O' rings.

7 SERVICE, SPARES AND ACCESSORIES

7.1 Introduction

BOC Edwards products, spares and accessories are available from BOC Edwards companies in Belgium, Brazil, China, France, Germany, Israel, Italy, Japan, Korea, Singapore, United Kingdom, U.S.A and a world-wide network of distributors. The majority of these centres employ Service Engineers who have undergone comprehensive BOC Edwards training courses.

Order spare parts and accessories from your nearest BOC Edwards company or distributor. When you order, state for each part required:

- Model and Item Number of your equipment
- Serial number
- Item Number and description of part.

7.2 Service

BOC Edwards products are supported by a world-wide network of BOC Edwards Service Centres. Each Service Centre offers a wide range of options including: equipment decontamination; service exchange; repair; rebuild and testing to factory specifications. Equipment which has been serviced, repaired or rebuilt is returned with a full warranty.

Your local Service Centre can also provide BOC Edwards engineers to support on-site maintenance, service or repair of your equipment.

For more information about service options, contact your nearest Service Centre or other BOC Edwards company.

7.3 Spares

The maintenance kits listed in Table 10 contain all of the parts you will need to maintain your pump. The maintenance kits also include instructions for the use of the kits.

Use the Clean and Overhaul Kit for routine maintenance operations. Use the Blade Kit together with the Clean and Overhaul Kit when you must renew the blade assembly in the rotary pump.

Spare	Item Number
Clean and Overhaul Kit	A363-01-131
E1M18 Blade Kit	A343-01-041
E2M18 Blade Kit	A363-01-020
Ultragrade 19 Oil (4 litres)	H110-25-013
Capacitor Kit, 100/200 V, 1-phase motor	A505-91-800

Table 10 – Spares Item Numbers

E1M18 and E2M18 Rotary Vacuum Pumps

7.4 Accessories

7.4.1 Introduction

A range of accessories is available for the E1M18 and E2M18 pumps, as shown in Figure 12.

The accessories are briefly described in the following sections. Refer to Table 11 for the Item Numbers of these accessories.

Accessory	Item Number
ITO20K Inlet Catchpot	A441-10-000
ITF20K Inlet Dust Filter	A442-15-000
ITD20K Inlet Desiccant Trap	A445-10-000
ITC20K Inlet Chemical Trap	A444-10-000
EMF20 Outlet Mist Filter	A462-29-000
PV25EK Valve: 200/240 V, 1-phase, 50/60 Hz	C413-01-000
PV25EK Valve: 110/127 V, 1-phase, 50/60 Hz	C413-03-000
FL20K Foreline Trap	A133-05-000
Vibration Isolators (pack of four)	A248-01-412
ODE 1/4 Oil Drain Extension	A505-03-000
Pump Inlet Adaptor	C105-20-201
Flexible Bellows	C105-14-670
Pump Outlet Adaptor	C105-01-414
Gas Ballast Banjo Elbow Assembly	A500-06-003
Gas Ballast Valve: 110 V, 50/60 Hz	A500-06-984
Gas Ballast Valve: 240 V, 50/60 Hz	A500-06-930

Table 11 – Accessory Item Numbers

7.4.2 Inlet Catchpot

The Inlet Catchpot traps any liquid droplets and prevents their entry into the pump.

7.4.3 Inlet Dust Filter

The Inlet Dust Filter protects the pump against abrasive dust.

7.4.4 Inlet Desiccant Trap

Use a Desiccant Trap when you pump limited quantities of water vapour at high pumping speeds to a low vapour pressure.

7.4.5 Inlet Chemical Trap

The Inlet Chemical Trap protects the pump against chemically active gases.

7.4.6 Outlet Mist Filter

The Outlet Mist Filter separates and traps oil droplets in the pump outlet to prevent oil mist discharge. The Mist Filter is supplied with an adaptor to connect it to the pump outlet.

E1M18 and E2M18 Rotary Vacuum Pumps

AW/6516/A

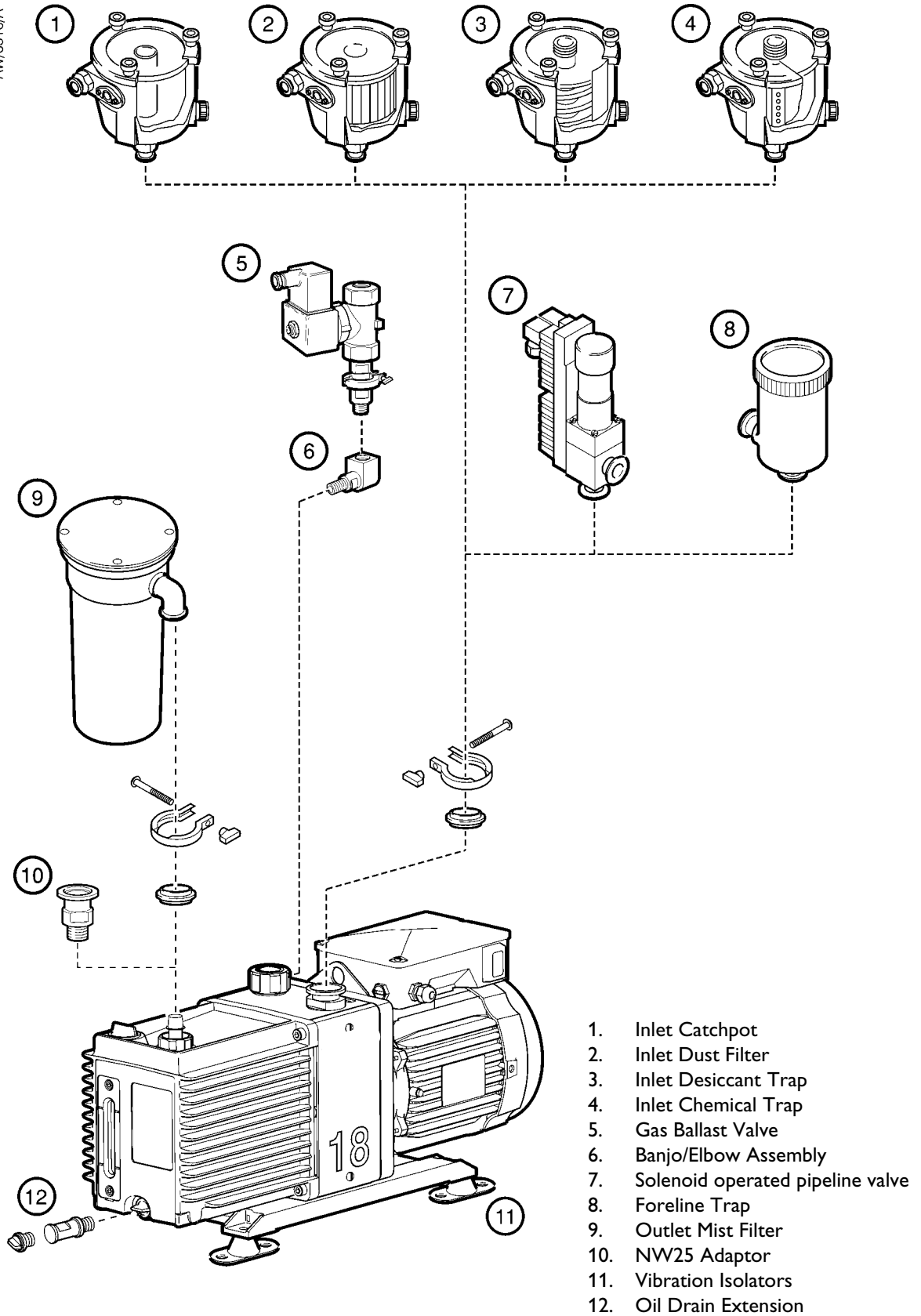

Figure 12 – Accessories

7.4.7 Solenoid Operated Pipeline Valve

Fit the Pipeline Valve between your vacuum system and the pump inlet to provide additional system protection when the pump is switched off.

7.4.8 Foreline Trap

Use a Foreline Trap on a clean pumping system to prevent back-migration of rotary pump oil vapour into your vacuum system.

7.4.9 Vibration Isolators

The Vibration Isolators reduce transmission vibration and noise when the pump is floor or frame mounted and help to reduce strain when the mounting area is uneven.

7.4.10 Oil Drain Extension

Fit the Oil Drain Extension between the oil drain port on the pump and the oil drain-plug to make the drainage of oil from the pump easier.

7.4.11 Pump Inlet Adaptor

This is an NW25 to 28 mm bore tube adaptor, supplied with connection hardware. Attach this adaptor to the NW25 pump-inlet to connect 28 mm bore plastic or rubber tube.

7.4.12 Flexible Bellows

Use Flexible Bellows to connect the pump-inlet to your vacuum system. We recommend that you use bellows when you use Vibration Isolators.

7.4.13 Pump Outlet Adaptor

This is a $\frac{3}{4}$ inch BSP to NW25 adaptor. Use this adaptor when you remove the hose adaptor supplied fitted to the pump outlet to adapt the $\frac{3}{4}$ inch BSP thread to NW25 pump inlet.

7.4.14 Gas Ballast Banjo/Elbow Assembly

Use this $\frac{3}{4}$ inch BSP assembly when a remote ballast supply, or gas ballast valve, is fitted.

7.4.15 Gas Ballast Valve

Use this to control the gas-ballast remotely. You will also need the Gas Ballast Banjo/Elbow Assembly (see Section 7.4.14) when you fit this accessory.