

Instruction Manual

T-Station 75



Description	Item Number	Description	Item Number
T-Station 75W NW40 200-230 V 50/60 Hz	TS75W1001	T-Station 75D NW40 200-230 V 50/60 Hz	TS75D1001
T-Station 75W NW40 100-120 V 50/60 Hz	TS75W1002	T-Station 75D NW40 100-120 V 50/60 Hz	TS75D1002
T-Station 75W ISO63 200-230 V 50/60 Hz	TS75W2001	T-Station 75D ISO63 200-230 V 50/60 Hz	TS75D2001
T-Station 75W ISO63 100-120 V 50/60 Hz	TS75W2002	T-Station 75D ISO63 100-120 V 50/60 Hz	TS75D2002
T-Station 75W CF63 200-230 V 50/60 Hz	TS75W3001	T-Station 75D CF63 200-230 V 50/60 Hz	TS75D3001
T-Station 75W CF63 100-120 V 50/60 Hz	TS75W3002	T-Station 75D CF63 100-120 V 50/60 Hz	TS75D3002

Chemtech Scientific provides access to this content as a courtesy.
We do not own the content contained in this document.
All rights and credit go directly to its rightful owners.
www.chemtechsci.com
Call us at: 484-424-9415



Declaration of Conformity

We,



declare under our sole responsibility, as manufacturer and person within the EU authorised to assemble the technical file, that the product(s)

T-Station 75

T S 7 5 - X X - 0 0 X



The material numbers cover a family of products where the following features may vary:- turbomolecular pump inlet flanges, electrical supply and backing pumps.

Backing pumps:
E2M1.5
XDD1

to which this declaration relates is in conformity with the following standard(s) or other normative document(s)

EN ISO 12100-2: 2003
+ A1: 2009

EN1012-2:1996, A1: 2009

EN61010-1: 2001

EN 61326-1: 2006

Safety of Machinery. Basic Concepts, General Principles for Design. Technical Principals.

Compressors and Vacuum Pumps. Safety Requirements, Vacuum Pumps.

Safety Requirements for Electrical Equipment for Measurement, Control and Laboratory Use. General Requirements.

Electrical Equipment for Measurement, Control and Laboratory Use. EMC requirements. General Requirements. Industrial location, Class B Emissions.

and fulfils all the relevant provisions of

2006/42/EC

Machinery Directive

2006/95/EC

Low Voltage Directive

2004/108/EC

Electromagnetic Compatibility (EMC) Directive

2002/95/EC*

Restriction of Certain Hazardous Substances (RoHS) Directive

* *i.e. The product(s) contain less than - 0.1wt% for hexavalent chromium, lead, mercury, PBB and PBDE; 0.01wt% for cadmium - in homogeneous materials (subject to the exemptions allowed by the Directive). This information relates only to products sold on or after the date of this certificate. Edwards has taken all reasonable steps to confirm this statement, which is based mainly on information from our suppliers. Whilst the RoHS Directive does not legally apply to this vacuum equipment, we recognize that component compliance is relevant to many of our customers.*

Note: This declaration covers all product serial numbers from the date this Declaration was signed onwards.

22.03.2011 Burgess Hill

Barrie Brewster, Technical Manager Scientific Products

This product has been manufactured under a quality system registered to ISO9001

Contents

Section	Page
1 Introduction	1
1.1 Scope and definitions	1
1.2 Description	2
1.2.1 Overview	2
1.2.2 General description of the T-Station major components	2
2 Technical data	4
2.1 General	4
2.2 Operating and storage data	4
2.3 Electrical connections	4
2.4 Electrical data	7
2.5 Pumping media	8
2.6 Materials exposed to gases pumped	9
2.7 Vent gas specification and vent control data	9
3 Installation	11
3.1 Safety	11
3.2 Unpack and inspect	11
3.3 Locate the T-Station	12
3.4 Bench-top fixing	12
3.5 Fill the rotary pump with oil	12
3.6 Connect the T-Station to your vacuum system	13
3.7 Connect to your exhaust extraction system	13
3.8 Connect the electrical supply	14
3.9 Configure the T-Station	14
3.9.1 Turbo pump delay	14
3.9.2 Connecting a vacuum gauge	15
3.10 Commissioning the installation	16
4 Operation	17
4.1 Control panel description	17
4.2 Start up	17
4.3 Menu structure	18
4.3.1 Turbo screen	19
4.3.2 Gauge screen	20
4.3.3 Vent valve screen	21
4.3.4 Turbo set-point screen	21
4.3.5 Calibrate gauge screen	23
4.3.6 Units screen	24
4.4 Gas-ballast control (E2M1.5)	25
4.5 Electrical supply failure	25
5 Maintenance	26
5.1 Safety	26
5.2 Maintenance plan	26
5.3 Inspect the hoses, pipelines and connections	27
5.4 Fault-finding	27
5.5 Error numbers	28
5.6 Factory default settings	29

6	Storage and disposal	30
6.1	Storage	30
6.2	Disposal	30
7	Spares and accessories	31
7.1	Introduction	31
7.2	Spares	31
7.3	Accessories	31
7.3.1	TAV vent-valve and vent-port adaptor (for DX turbo pump)	31
7.3.2	Outlet mist filter (for E2M1.5 rotary vacuum pump)	31
	Index	33

For return of equipment, complete the HS Forms at the end of this manual.

Illustrations

Figure		Page
1	Components of the T-Station	3
2	Equipment dimensions (mm)	5
3	Pin connections for a 15-way sub-miniature 'D' type socket	6
4	Pin connections for an 8-way RJ45	6
5	Maximum allowed rate of pressure rise during venting: pressure against time (with pump initially at full rotational speed) 10	
6	Turbomolecular pump start delay with XDD1 diaphragm pump	15
7	Front panel display	17
8	Menu Structure	18

Tables

Table		Page
1	Turbo pump connector pin-out	6
2	Active gauge connector pin-out	7
3	Electrical data	7
4	T-Station technical data	9
5	Vent gas specification and vent control	9
6	Checklist of components	11
7	Front panel symbols and their functions	17
8	Menu items	17
9	Fault finding	27

Associated publications

Publication title	Publication number
Diaphragm Pump - XDD1	A746-02-885
Rotary Vane Pump - E2M0.7 / E2M1.5	A371-32-880
Turbomolecular Pumps - EXT75DX / EXT255DX	B722-40-880

1 Introduction

1.1 Scope and definitions

This manual provides installation, operation and maintenance instructions for the Edwards T-Station. You must use the T-Station as specified in this manual.

Read this manual before you install and operate the T-Station. Important safety information is highlighted as WARNING and CAUTION instructions; you must obey these instructions. The use of WARNINGS and CAUTIONS is defined below.



WARNING

Warnings are given where failure to observe the instruction could result in injury or death to people.

CAUTION

Cautions are given where failure to observe the instruction could result in damage to the equipment, associated equipment and process.

Details of the Supplementary Publications is provided at the end of the Contents list of this manual. These Supplementary Publications can be accessed from the CD manual which is supplied with your T-Station.

The Supplementary Publications you receive also contain WARNING and CAUTION instructions. When you install and operate the T-Station, you must refer to these Supplementary Publications and obey all of the WARNING and CAUTION instructions which they contain.

The following IEC warning labels appear on the product and in the manual:



Warning - refer to accompanying documentation.



Warning - risk of electric shock.



Warning - hot surfaces.

The units used throughout this manual conform to the SI international system of units of measurement.

1.2 Description

1.2.1 Overview

The T-Station is a small compact fully automatic pumping system which is suitable for a wide range of vacuum applications. The T-Station can be supplied with either an XDD1 oil free diaphragm pump or an E2M1.5 rotary vane pump, both system variants use an EXT75DX turbomolecular pump.

The T-Station is controlled by an easy to use touch pad control module. A single gauge input included can be connected to a range of Edwards active gauges allowing for pressure measurement and or control management of the turbomolecular pump.

The compact size of the T-Station is ideal for use on bench-tops or suitable mobile platforms. The open system configuration allows easy maintenance of the main pump components.

1.2.2 General description of the T-Station major components

For the general description of the major components used on the T-Station, click on (CD) the appropriate instruction manual reference against each product type.

Diaphragm pump	XDD1	A746-02-885
Rotary vane pumps	E2M0.7 / E2M1.5	A371-32-880
Turbomolecular pumps	EXT75DX / EXT255DX	B722-40-880

Figure 1 - Components of the T-Station

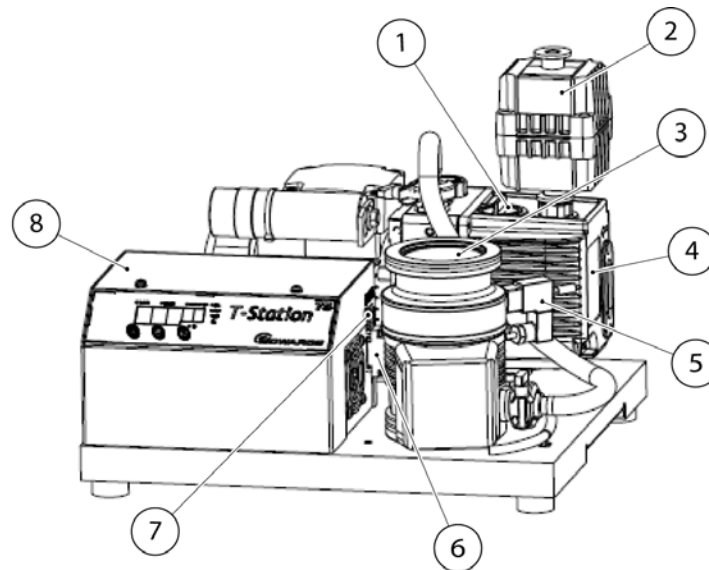

Front view (T-Station with E2M1.5 backing pump option)

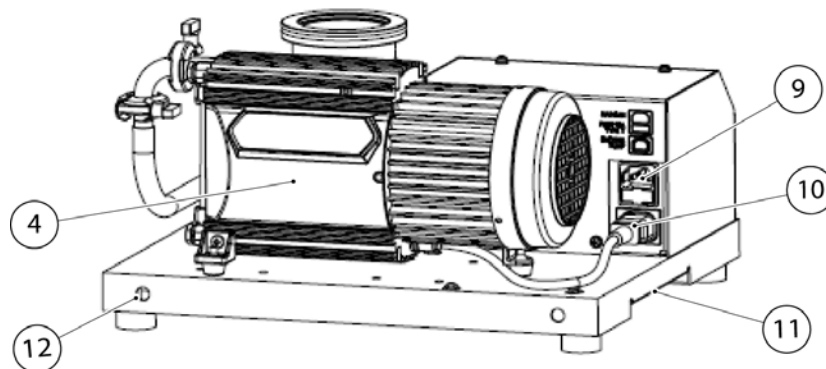

Rear view (T-Station with XDD1 backing pump option)

- | | |
|---|--|
| 1. E2M1.5 gas-ballast control | 7. Vacuum gauge input |
| 2. Backing pump oil mist filter (optional accessory not supplied) | 8. T-Station control unit |
| 3. Turbomolecular pump inlet | 9. Mains input (fused refer to Section 2.3) |
| 4. Backing pump | 10. Backing pump mains connector |
| 5. TAV vent valve (optional accessory not supplied) | 11. T-Station lifting handles |
| 6. Turbomolecular pump connector | 12. T-Station fixing points for bench top mounting (refer to Section 3.4) |

2 Technical data

Note: The operating, storage conditions and performance of the T-Station may depend on the type of backing pump fitted to the T-Station; refer to the technical data in the appropriate supplementary publications.

2.1 General

Dimensions	Refer to Figure 2
Electrical data	Refer to Table 3 - Electrical data
Degree of protection (to IEC34-5: 1981)	IP20
Mass	
XDD1 combination	17 kg max
E2M1.5 combination	21 kg max

2.2 Operating and storage data

Ambient operating temperature range	12 °C to 40 °C
Ambient storage temperature range	-30 °C to 70 °C
Maximum operating altitude	2000 m max
Equipment type	Indoor use only
Pollution degree	2
Maximum ambient operating humidity	Max 90% RH non cond at 40 °C
Sound level	56 dB(A)
Maximum outlet pressure	
XDD1 pump	1.1 bar absolute (1.1×10^5 Pa)
E2M1.5 pump	1.5 bar absolute (1.5×10^5 Pa)
Maximum permitted external magnetic field	5 mT (DX turbo)

2.3 Electrical connections

Electrical supply (refer to Figure 1 item 9)	
Inlet plug type	IEC60320
Integral fuse rating	10 A Type T, 20 mm
Backing pump (refer to Figure 1 item 10)	
Outlet socket type	IEC60320
Turbomolecular pump (refer to Figure 1 item 6)	
Connector type	15-way sub-miniature 'D' type socket
Power supply	24 V d.c. nominal
Maximum output power	80 W
Active gauge (refer to Figure 1 item 7)	
Connector type	RJ45 8-way
Power supply	24 V d.c. nominal
Maximum power rating	4 W

Figure 2 - Equipment dimensions (mm)

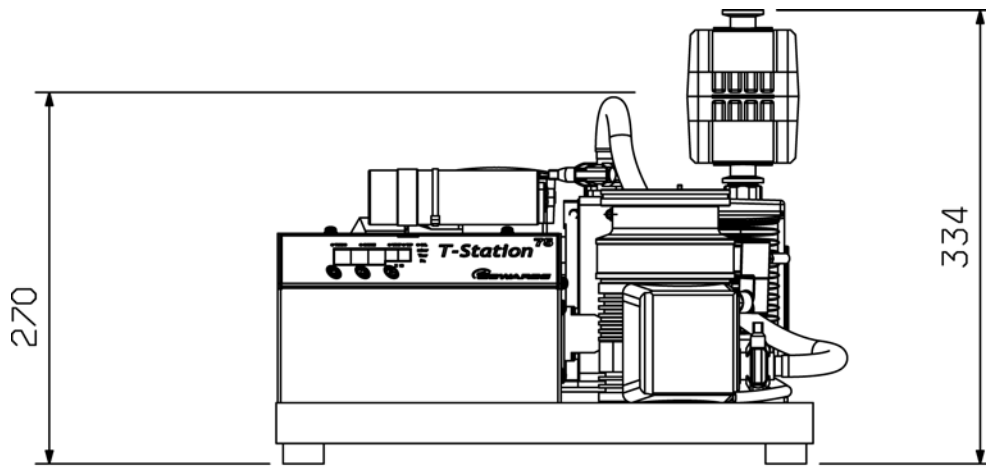

E2M1.5/EXT75DX combination

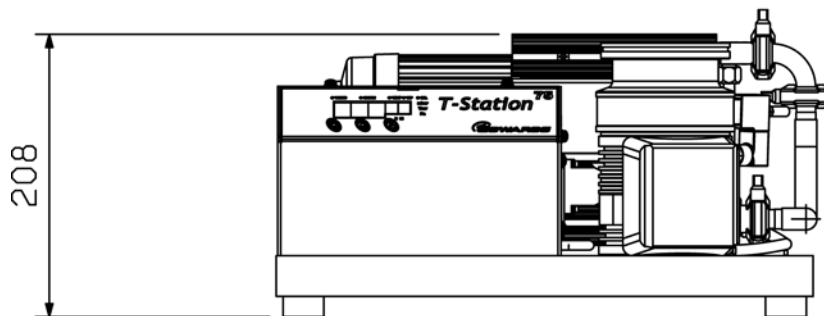
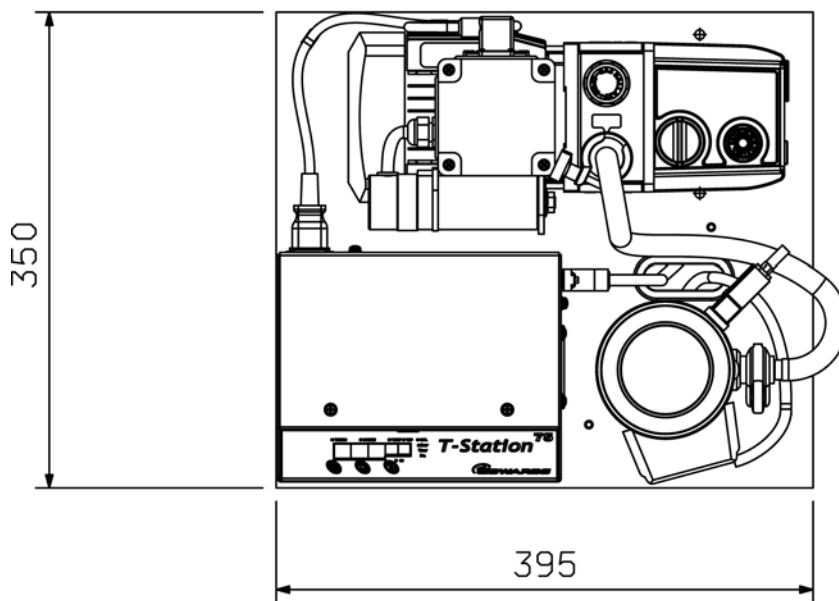

XDD1/EXT75DX combination

Figure 3 - Pin connections for a 15-way sub-miniature 'D' type socket

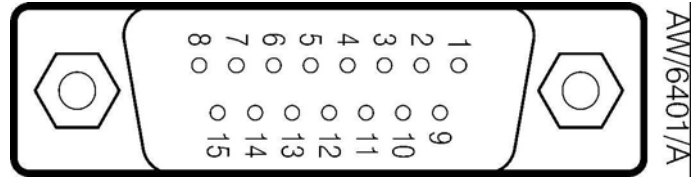

Table 1 - Turbo pump connector pin-out

Pin	Function
1	Power supply positive
2	Signal common
3	Start signal output
4	RS232 Tx
5	Serial enable output
6	Power supply positive
7	RS232 Rx
8	Power supply common
9	Speed signal input
10	Screen
11	Power supply positive
12	Screen
13	Power supply common
14	Power supply common
15	Normal signal input

Figure 4 - Pin connections for an 8-way RJ45

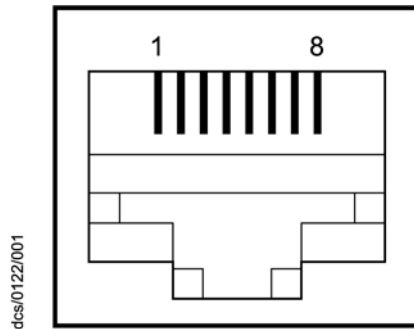

Table 2 - Active gauge connector pin-out

Pin	Function
1	Power supply positive
2	Power supply common
3	Signal input
4	Identification
5	Signal common
6	Control line 1
7	Control line 2
8	N/C

2.4 Electrical data

If your T-Station uses an E2M1.5, the motor start-up current is drawn for less than one second, so you must use slow-blow fuses to prevent unnecessary fuse failure when the pump starts. If you use the pump at temperatures lower than 12 °C (53.6 °F), the start-up current will be drawn for longer; this may cause the motor thermal overload device to open.

Table 3 - Electrical data

Pump combination	Supply Voltage 50/60 Hz	Current (A)		Power (W)
		Full load	Start	
XDD1 / EXT75DX	100	3.1	-	310
	120	2.6	-	
	200	1.6	-	
	230	1.35	-	
E2M1.5 / EXT75DX	100	4.7	13.6	470
	120	3.92	12.0	
	200	2.2	6.4	430
	230	1.9	5.7	

2.5 Pumping media



WARNING

Vent dangerous gases and gas mixtures safely, do not expose people to these gases. If pumping hazardous gases or vapours, observe the safety recommendations of the supplier of the gas/vapour.



WARNING

Do not use the turbo pump to pump pyrophoric or explosive gas mixtures, as it is not suitable for this purpose. The pump and its connections are not designed to contain an explosion.



WARNING

Do not expose any part of the human body to vacuum.

CAUTION

Do not use the turbo pump to pump gases containing more than 20% oxygen unless the pump is gas purged. If you do, the lubricant will polymerise and the pump may fail prematurely.

CAUTION

Do not use a turbo pump to pump mercury vapour and do not allow mercury (for example, from a McLeod gauge) to come into contact with the pump. If you do, the pump rotor may corrode and fail.

Note: Concentrations of gases may be modified by the compression of the pump.

The turbo turbo pump is designed to pump the following residual gases normally used in high-vacuum systems:

- Air
- Methane
- Propane
- Butane
- Carbon monoxide
- Nitrogen
- Hydrogen
- Carbon dioxide
- Neon
- Krypton
- Helium
- Ethane
- Argon

You can use the pump to pump oxygen and water vapour, subject to the following conditions:

- Oxygen - when the pump is purged by an inert gas, oxygen can be pumped at concentrations above 20% by volume. Refer to the EXT75DX instruction manual (B722-40-880) for Purge gas specification. However, if the pump is not purged, the oxygen concentration must be less than 20% by volume.
- Water vapour - you must ensure that vapour does not condense inside the pump.

If you wish to pump a gas not in the list above, contact your supplier for advice. If you do not contact your supplier, you may invalidate the warranty on the pump. The pump is not suitable for pumping aggressive or corrosive gases.

Table 4 - T-Station technical data

Parameter	EXT75DX ISO63	EXT75DX 63CF	EXT75DX NW40
Inlet pumping speed:			
N2	61 l s ⁻¹	61 l s ⁻¹	42 l s ⁻¹
He	57 l s ⁻¹	57 l s ⁻¹	49 l s ⁻¹
H2	53 l s ⁻¹	53 l s ⁻¹	48 l s ⁻¹
Inlet compression ratio:			
N2	> 1 x 10 ¹¹	> 1 x 10 ¹¹	> 1 x 10 ¹¹
He	1 x 10 ⁶	1 x 10 ⁶	1 x 10 ⁶
H2	5 x 10 ⁴	5 x 10 ⁴	5 x 10 ⁴
Ultimate pressure:			
with rotary vane backing pump *	< 5 x 10 ⁻⁹ mbar	< 5 x 10 ⁻¹⁰ mbar	< 5 x 10 ⁻⁹ mbar
with diaphragm backing pump †	< 5 x 10 ⁻⁸ mbar	< 5 x 10 ⁻⁹ mbar	< 5 x 10 ⁻⁸ mbar

* Ultimate pressure 48 hours after bakeout with 2-stage rotary vane backing-pump.

† Ultimate pressure 48 hours after bakeout with backing pressure < 5 mbar (500 Pa).

2.6 Materials exposed to gases pumped

The following materials and component types are exposed to the gases pumped:

Aluminium alloys, stainless steels, fluoroelastomer and nitrile O-rings, hydrocarbon lubricant, felt, rare earth magnets, silicon nitride, phenolic resin, carbon-fibre reinforced epoxy resin, fire retardant polypropylene, polyamide and PVC.

2.7 Vent gas specification and vent control data

Although the pump may be vented to atmosphere, high relative humidity of the air may greatly increase the subsequent pump-down time. To reduce pump-down times you should vent with dry, clean gases. Refer to the DX turbo pump manual (B722-40-880) for the vent valve connection and refer to Section 4.3.3 of this manual for a description of the vent options available on the T-Station and how to configure them.

Table 5 - Vent gas specification and vent control

Vent gas specification and control	Reference data
Vent gas	Dry air, nitrogen, argon and other inert gases
Maximum dew point at atmospheric pressure	-22 °C
Maximum size of particulates	1 µm
Maximum concentration of oil	0.1 parts per million
Recommended time for rotational speed to reach 50%	> 15 seconds
Maximum allowed rate of pressure rise	Refer to Figure 5

Figure 5 - Maximum allowed rate of pressure rise during venting: pressure against time (with pump initially at full rotational speed)

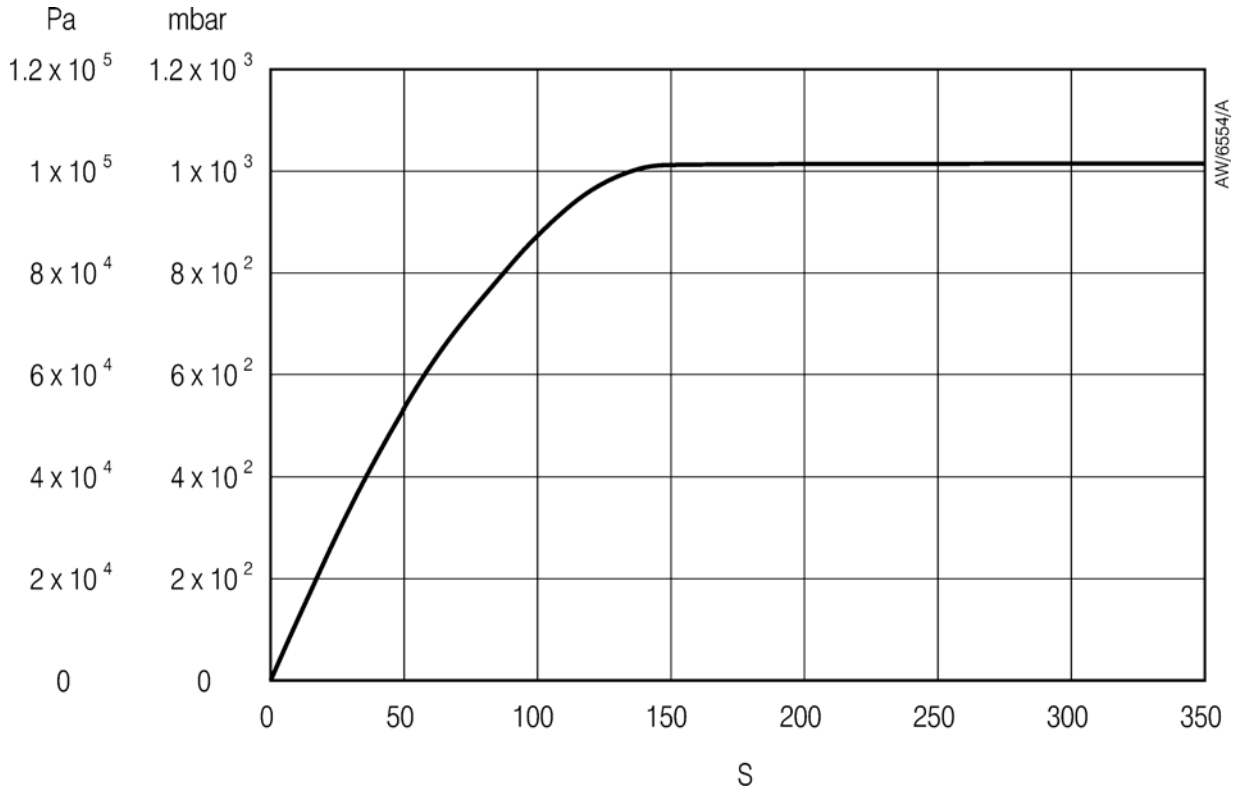

3 Installation

3.1 Safety



WARNING

Obey the safety instructions given below and take note of appropriate precautions. If you do not, you can cause injury to people and damage to equipment.

- When you refer to a manual supplied as a Supplementary Publication, you must obey all of the WARNING and CAUTION instructions in the manual.
- A suitably trained and supervised technician must install the T-Station.
- Check that all the required parts are available and of the correct type before you start work.
- Ensure that the installation technician is familiar with the safety procedures which relate to the products pumped. Wear the appropriate safety-clothing when you come into contact with contaminated components.
- Isolate the other components in your system from the electrical supply so that they cannot be operated accidentally.
- Do not reuse O-rings and Co-Seals if they are damaged.
- Dispose of components, grease and oil safely (refer to [Section 6](#)).
- Take care to protect sealing-faces from damage.
- We recommend you leak-test the system after installation is complete.

3.2 Unpack and inspect

Remove the outer cover and all packing materials, remove the protective covers from the inlet and outlet ports, inspect the system for any damage. If the T-Station is damaged, notify your supplier and the carrier in writing within three days; state your order number and invoice number. Retain all packing materials for inspection. Do not use the T-Station if it is damaged. Check that your package contains the items listed in [Table 6](#). If any item is missing, notify your supplier within three days.

If the T-Station is not to be used immediately, replace the protective covers. Store the T-Station in suitable conditions as described in [Section 6.1](#).

Table 6 - Checklist of components

Qty	Description	Check (✓)
1	T-Station	<input type="checkbox"/>
1	T-Station CD instruction manual P450-00-000	<input type="checkbox"/>
1	Ultragrade 15 oil 1 ltr (supplied only with E2M1.5)	<input type="checkbox"/>
1	Inlet seal (either trapped O-ring, Co-seal or copper compression gasket suitable for the inlet-flange type)	<input type="checkbox"/>
1	Connector (24 V) - for driving accessories from Podule socket	<input type="checkbox"/>
1	Inlet-strainer	<input type="checkbox"/>

3.3 Locate the T-Station



WARNING

Heavy objects can cause muscle strain or back injury. The mass of the T-Station will differ depending on the model supplied, refer to [Section 2.1](#) for the equipment mass.



WARNING

Important: The turbo pump used on the T-Station stores a large amount of kinetic energy when it is running at full speed. In the unlikely event of a malfunction (rotor seizure), the stored energy could cause a slight movement of the T-Station platform. If the T-Station is operating on a bench-top, we advise that the following steps should be taken:

- Position the T-Station at least 10-15 cm away from the edge of the bench-top and adjacent devices.
- and or,
- Tether or fix the T-Station to your bench-top, see [Section 3.4](#).

CAUTION

When locating the T-Station, care should be taken not to restrict the ventilation grid located under the base of the T-Station. Failing to observe this may result in over heating of the turbomolecular pump.

3.4 Bench-top fixing

There are two M8 fixing points located at the rear of the T-Station base (refer to [Figure 1](#), item 12). Using suitable brackets or straps (not supplied), we recommend that you should secure the T-Station to your bench-top to prevent excessive movement in the unlikely event of a pump failure. Please note, we cannot provide straps or brackets as we are unable to determine the best type fixing for your bench-top location. We recommend you should source or fabricate these fixings locally.

3.5 Fill the rotary pump with oil

If the T-Station uses an E2M1.5 rotary vane pump, you must fill it with the correct quantity of oil (supplied with the equipment) before you operate the equipment. For further information refer to the EM Rotary Vane Pump manual A371-32-880.

Fill the pump with oil as described below.

1. Remove the oil filler-plug.
2. Pour oil into the pump until the oil-level just reaches the MAX mark on the bezel at the top of the sight-glass. If the oil-level goes above the MAX mark, remove the drain-plug and drain the excess oil from the pump.
3. After a few minutes, recheck the oil-level. If the oil-level is now below the MAX mark, pour more oil into the pump.
4. Refit the oil filler-plug. Tighten the plug firmly by hand. Do not over tighten.

3.6 Connect the T-Station to your vacuum system



WARNING

Connect the turbo pump inlet to your vacuum system before applying power to the T-Station. This will ensure that the pump cannot operate accidentally causing injury.



WARNING

If you install your vacuum system directly onto the T-Station, the weight of the system must be no more than 10 kg and the centre of gravity must be positioned laterally within the bounds of the base plate. If this is not the case, the vacuum system must be supported to ensure that the T-Station does not topple.

The turbo pump can be securely fixed to the vacuum system via the inlet-flange. Make sure that the pump-inlet and all components fitted to the pump-inlet are clean and dust-free. If the pump-inlet is not kept clean, the pump-down time may be increased.

- If the pump has a CF flange, use the copper compression gasket supplied with the pump and use a full complement of bolts to connect the inlet-flange of the pump to the vacuum system.
- If the pump has an ISO flange, use a minimum of four claw clamps (each torque to 10 Nm) to connect the inlet-flange of the pump to the vacuum system. Alternatively, use a rotatable collar and the combined inlet screen and trapped O-ring supplied with the pump to connect the inlet-flange of the pump to the vacuum system; use a full complement of bolts with the rotatable collar.
- If the pump has an NW flange, use the centring ring supplied with the pump and a metal NW clamp to connect the inlet-flange of the pump to the vacuum system.

All inlet flange bolts must be re-tightened once the system is under vacuum. Ensure that no torques or other forces are transmitted to the pump from the vacuum system or the associated pipelines.

3.7 Connect to your exhaust extraction system

Note: This section applies to E2M1.5 versions only.



WARNING

Vent dangerous gases and gas mixtures safely, do not expose people to these gases. If pumping hazardous gases or vapours, observe the safety recommendations of the supplier of the gas/vapour.

The exhaust system must be configured so that the maximum pressure at the pump outlet does not exceed 0.5 bar gauge (1.5 bar absolute, 1.5×10^5 Pa) at full pump throughput. Make sure that the exhaust pipeline cannot become blocked. If you have an exhaust- isolation valve, make sure that you cannot operate the pump with the valve closed.

3.8 Connect the electrical supply



WARNING

Ensure that the electrical installation of the T-Station conforms with your local and national safety requirements. It must be connected to a suitably fused and protected electrical supply and a suitable earth point.

CAUTION

Always make the electrical connections to the T-Station after the equipment has been installed on your vacuum system. Always disconnect the electrical supply from the T-Station before removing the equipment from the vacuum system.

Check that your electrical supply is suitable for this equipment. Refer to [Table 3](#) for the electrical requirements for this equipment. Make the electrical connection to the T-Station using a cable fitted with an IEC60320 connector. A range of suitable cables is available from your supplier.

3.9 Configure the T-Station

As supplied from the factory, the T-Station will control the system as follows:

System start is selected:

- The TAV vent valve will close*.
- The backing pump will turn on.
- The turbomolecular pump will start accelerating up to full rotational speed.

System off is selected:

- The backing pump will turn off.
- The turbomolecular pump drive will turn off and the pump will start to decelerate.
- The TAV vent valve will open fully from 50% of full rotational speed*.

* This operation refers to systems which have been fitted with an Edwards TAV vent valve (optional accessory). For more vent options refer to [Section 4.3.3](#).

3.9.1 Turbo pump delay

The T-Station can be configured to delay the turbo pump after the backing pump has started (refer to [Section 4.3.4](#)), this is helpful to prevent the turbomolecular pump from accelerating under high pressure for a prolonged period if the volume being pumped is greater than 2 litres. This option is especially useful if your T-Station uses an XDD1 diaphragm pump. Below the chart shows the recommended delay period for a turbo / XDD1 pump combination.

Figure 6 - Turbomolecular pump start delay with XDD1 diaphragm pump

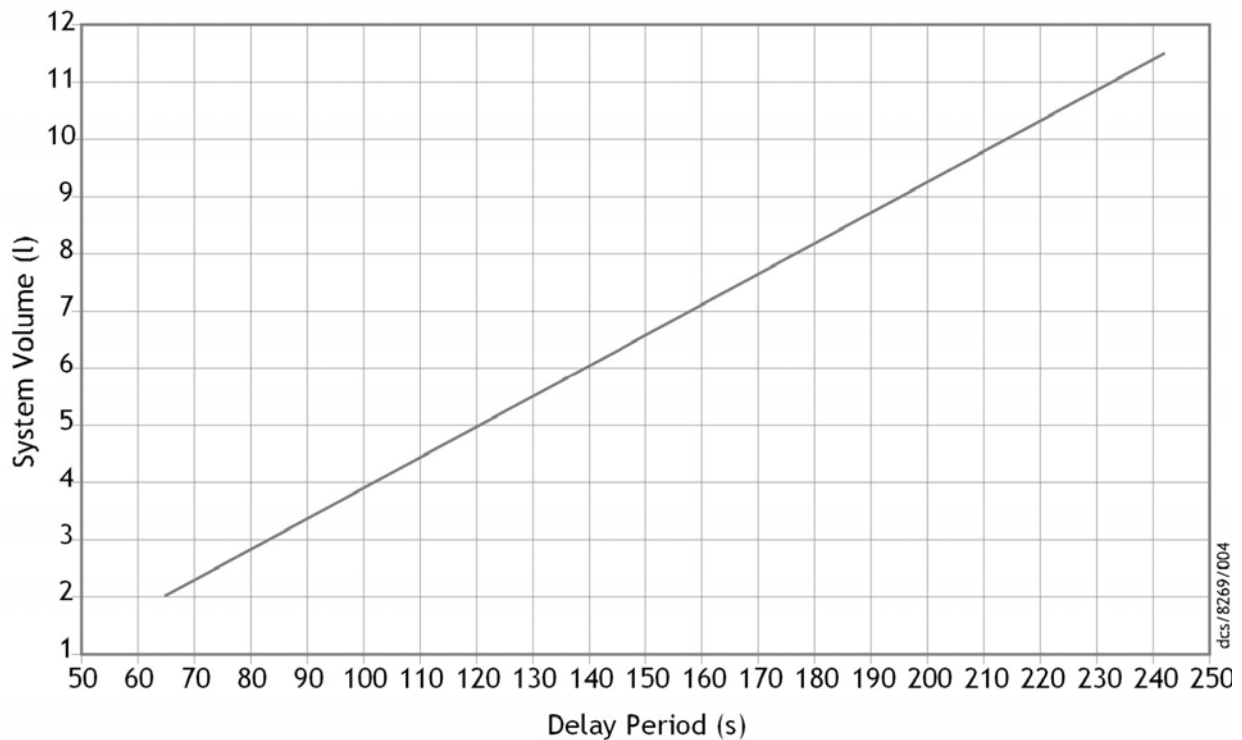

3.9.2 Connecting a vacuum gauge

CAUTION

Do not connect Barocel capacitance manometers to the T-Station gauge connector. Doing so will result in damage to the gauge and will invalidate the warranty.

A single compatible active gauge can be fitted to the T-Station. Fit the gauge using an Edwards active gauge cable into the gauge connector located on the side of the controller housing (refer to [Figure 1](#)). For active gauge control and set-up refer to [Section 4.3.2](#).

The following Edwards active gauges are suitable for use with the T-Station:

- APG100 Active Pirani vacuum gauge
- APGX-H Active Linear Convection gauge
- AIM-X Active Inverted Magnetron gauge
- WRG-S Active Wide Range gauge
- ASG Active Strain gauge

3.10 Commissioning the installation

After you have installed the T-Station, use the following procedure to test the system.

1. Make sure that all the electrical connections are secure.
2. Switch on the electrical supply and your exhaust-extraction system (if available).
3. To operate the system press the START/STOP key. Check that the equipment operates as described in [Section 3.9](#).
4. Check that the turbo pump reaches normal speed. If the pump inlet is valved or capped off, it should take approximately 100 - 150 seconds for the turbo to reach normal speed. If you have attached a vacuum chamber to the pump inlet, this time may take longer.
5. To turn OFF the system, press the START/STOP key followed by the ENTER key to confirm. Check that the equipment closes down as described in [Section 3.9](#).

For full operational details and how to navigate using the front panel control key pad refer to [Section 4.3](#).

4 Operation



WARNING

Do not attempt to move the T-Station while the Turbo pump is rotating. Doing so may cause severe damage to the pump and could cause injury.

CAUTION

To familiarise yourself with the vacuum pumps installed on your T-Station, it is advisable to read the relevant instruction manuals (refer to [Section 1.2.2](#)).

4.1 Control panel description

Figure 7 - Front panel display

Table 7 - Front panel symbols and their functions

Key pad symbol	Name	Function
	START / STOP	Turns the pumps on and off. Returns to Turbo Menu Screen.
	ENTER	Selects or confirms current menu option. Controls active gauges.
	NEXT	Moves to next menu. Scrolls through menu options.

The LEDs along the top of the T-Station display indicate which menu screen is currently being shown on the numeric display. To move to the next menu item press the NEXT key, and to return to the Turbo menu press the START/STOP key. The available items are listed in order in [Table 8](#).

Table 8 - Menu items

Turbo screen
Gauge screen
Vent valve screen
Turbo set-point (TSP) screen
Calibrate gauge screen
Units screen

4.2 Start up

When you apply power to the T-Station all LEDs in the display will light for 2 seconds to confirm operation. The software version will then be displayed for a further 2 seconds. If you need to contact Edwards for support regarding the T-Station, please have this software version number available.

4.3 Menu structure

Figure 8 shows the view screen shortcuts and menu structure for the T-Station control display. They also give an indication as to what buttons will take you within the menu layout.

Figure 8 - Menu Structure

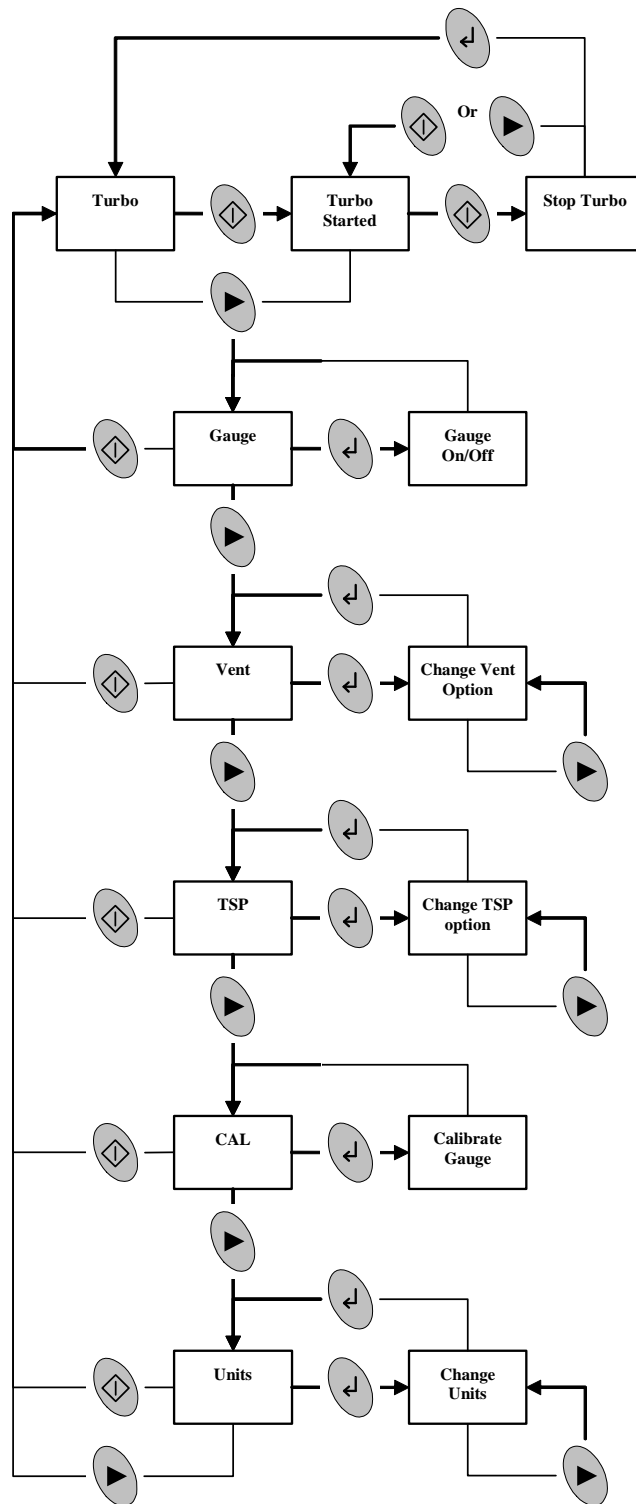

4.3.1 Turbo screen

When the Turbo screen is selected, the Turbo LED is lit and the speed of the turbomolecular pump is displayed in percentage of full speed. If no turbo pump is connected the display shows "---".

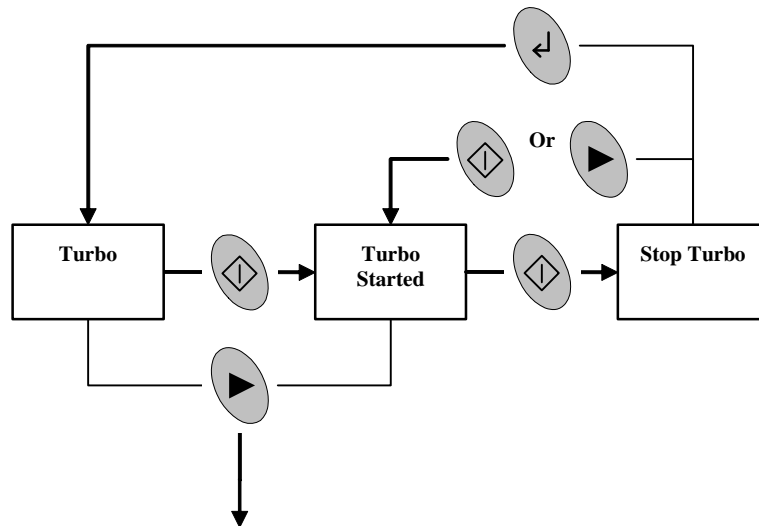

4.3.1.1 Starting the pumps

When the START/STOP key is pressed, both the turbo and backing pumps start. The display shows the turbo pump is accelerating by flashing the top left portion of the percentage sign. When the turbo reaches normal speed (>80% default) the percentage sign stops flashing and remains steady.

If a Turbo Set-point has been set, only the backing pump starts when the START/STOP key is pressed. The TSP LED flashes until the set-point has been reached. Once the set-point has been reached the turbo pump starts and the TSP LED turns OFF. If no Turbo Set-point has been set, the TSP LED remains OFF.

4.3.1.2 Stopping the pumps

To stop the pumps press the START/STOP key; the display will show "Stop" for three seconds. Press the ENTER key within that time to stop the pumps. If the ENTER key has not been pressed, or the START/STOP or NEXT keys are pressed, the display returns to Turbo speed and the pumps remain running.

When the Turbo is decelerating the bottom right portion of the percentage sign flashes until the turbo pump has completely stopped.

4.3.1.3 Turbo screen key actions

Keys	Short Press	Long Press
START	START the Turbo, or Initialise Turbo STOP sequence, or Cancel Turbo STOP, or force Turbo STOP when in Error	-
ENTER	Acknowledge Turbo STOP	Fault code display when in Error
NEXT	Go to Gauge Screen, or Cancel Turbo STOP	Scroll through menu screens

4.3.2 Gauge screen

When the Gauge screen is selected, the Gauge LED is lit and the gauge pressure reading is displayed in the selected units. If no gauge is connected the display shows "---".

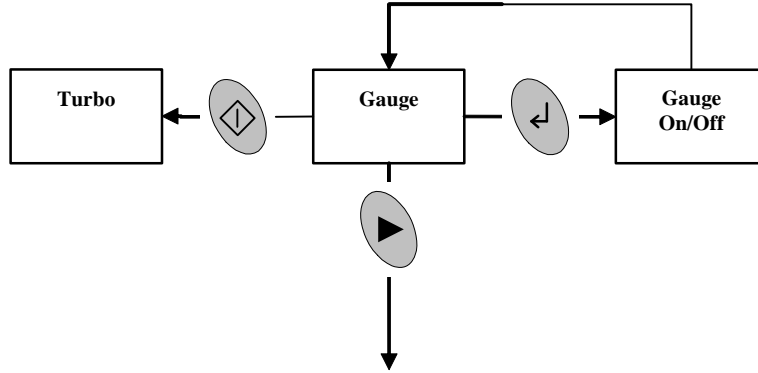

4.3.2.1 Connecting a gauge

When a gauge is first connected the display shows "ID" followed by a number to identify the new gauge. If the gauge is an ASG, the display then goes to ASG Range Select, otherwise the display reverts to showing the pressure reading. If the gauge type is not supported the display shows "???". When no gauge is connected the display shows "---".

4.3.2.2 ASG range select

When an ASG is connected the display changes to select the ASG range. 1000 mbar is assumed by default, and the display flashes "1.0³". Press the NEXT key to select between 1000 and 2000 mbar, then press the ENTER key to confirmed the selection.

4.3.2.3 Gauge ON/OFF control

Gauges which support ON/OFF control (e.g. AIM gauges) can be turned ON and OFF using the ENTER key. When first connected the gauge is in the OFF state and the display shows "OFF". When the gauge is turned on the display will show "Str" whilst the gauge is starting up, and will then display pressure.

4.3.2.4 Gauge screen key actions

Keys	Short Press	Long Press
START	Go to Turbo Screen	-
ENTER	ON/OFF control of supported gauge or Acknowledge Error	-
NEXT	Go to Vent Control Screen	Scroll through menu screens

4.3.3 Vent valve screen

If you have a TAV solenoid vent valve connected to the turbo pump podule the operation of the valve is controlled by the vent valve screen. When the Vent Valve screen is selected, the Vent LED is lit and the current vent valve control setting is displayed. The default is "50%". The Vent Valve menu is not available if the Turbo is running.

To change the vent valve setting press the ENTER key, then use the NEXT key to choose between 50%, CtrlId and FAN. Press the ENTER key again to confirm the selection.

- 50% The vent valve will open when the speed of the turbo pump has dropped to 50%
- CtrlId Controlled venting from 100% to 50% full rotational speed; vent valve opens fully below 50%
- Fan The socket on the turbo pump podule is permanently powered so the vent valve will remain closed. This can also be used to provide power to an air cooler (e.g. ACX75) for remote mounting the turbo pump.

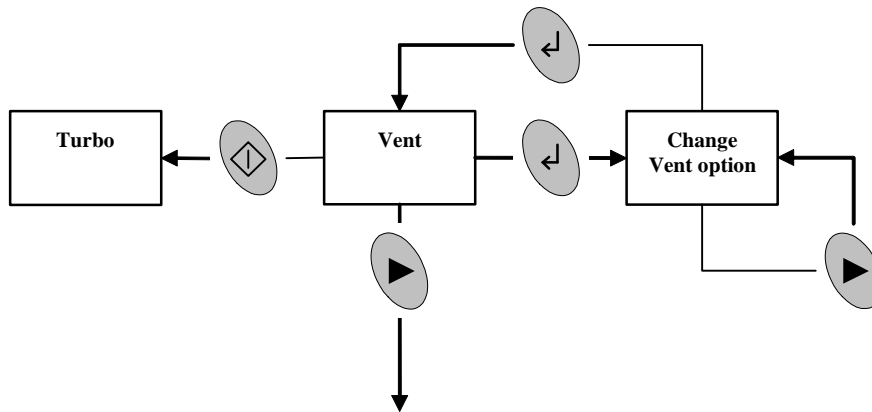

4.3.3.1 Vent valve screen key actions

Keys	Short Press	Long Press
START	Go to Turbo Screen	-
ENTER	Enter edit mode, or confirm selection	-
NEXT	Next vent option, or go to TSP Control Screen	Scroll through vent options in edit mode or Scroll through menu screens

4.3.4 Turbo set-point screen

The Turbo Set-Point screen is used to configure the start delay of the turbo pump. When the Turbo Set-point screen is selected, the TSP LED is lit and the current set-point is displayed. The default is "OFF". The Turbo Set-point menu is not available if the Turbo is running or the selected units are Volts.

To change the turbo set-point press the ENTER key, then use the NEXT key to choose between off, time delay and pressure set-point. Press the ENTER key again to confirm the selection.

When time delay is selected the display will show the delay time in seconds. The default time is 120 s. This means that the turbo pump will start after a delay of 120 s from when the START key is pressed. To change the value of the delay time press and hold the ENTER key to start number entry mode.

If you have an Active Gauge connected to your system you can use the pressure set-point to start the turbo pump once the pressure has fallen below the set-point value. When pressure is selected the display shows the set-point pressure. The default Pressure is "5.0⁰" mbar shown as an exponential. To change the pressure set-point, press and hold the ENTER key to start number entry mode.

Note: If you set the Turbo Set-Point to pressure but do not connect a gauge then the turbo pump will not start.

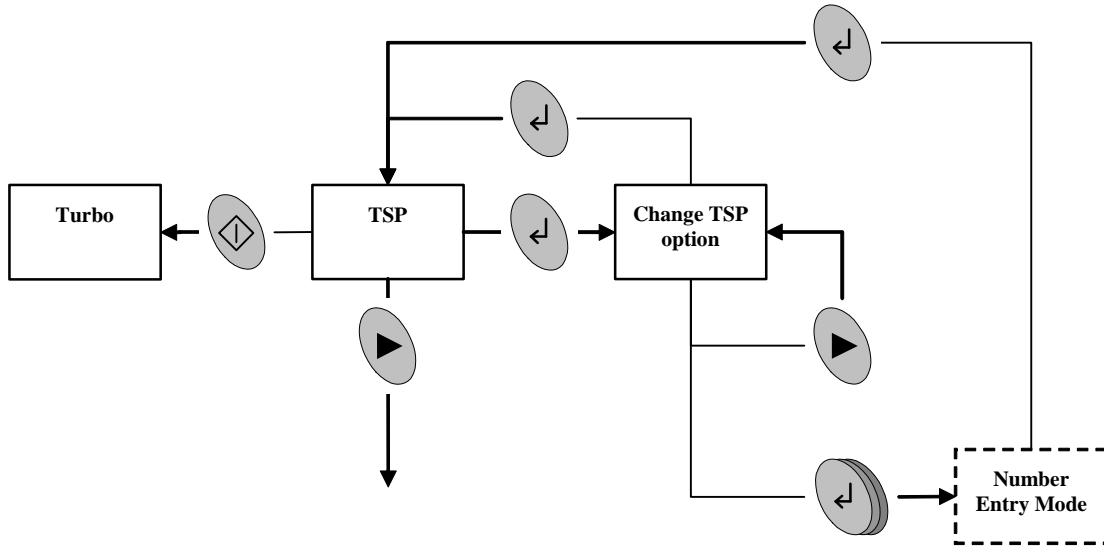

4.3.4.1 Number entry mode

When the ENTER key is pressed and held on either the time or pressure option number entry mode is entered. The first digit starts flashing, and the time or pressure can be edited.

Press the NEXT key to adjust the value, then press the ENTER key to confirm the digit and then move on to the second digit, which is adjusted similarly. The ENTER key confirms the digit and then moves to the final digit of the Time set-point, or the exponent of the pressure set-point. The exponent of the pressure set-point is adjusted as a single value in the range -10 to +6.

The final press of ENTER confirms the complete number and returns to showing the set-point value. The TSP is set after the complete number is entered.

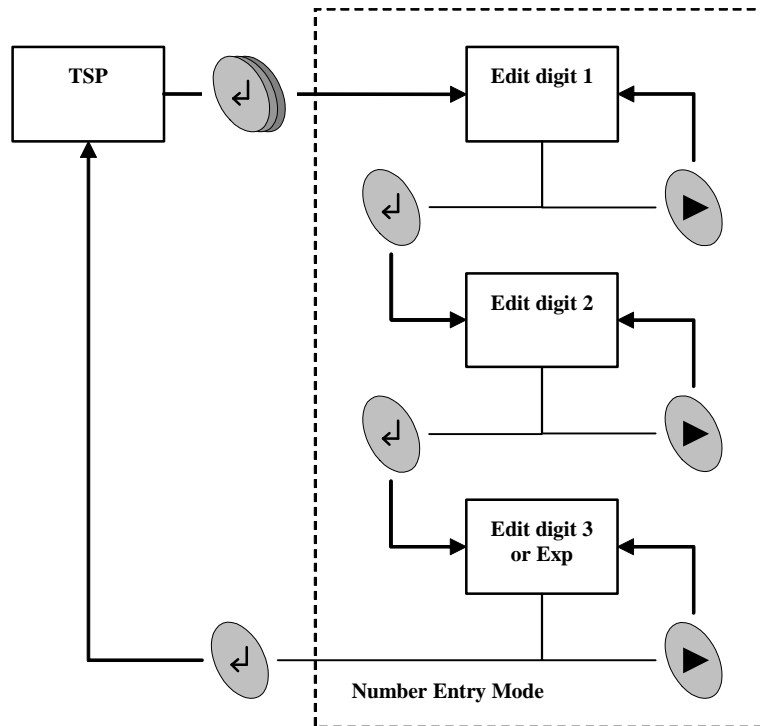

4.3.4.2 TSP screen key actions

Keys	Short Press	Long Press
START	Go to Turbo Screen	-
ENTER	Enter edit mode, or confirm selection	Enter Number Entry mode
NEXT	Next TSP option, Next number or Go to Gauge Calibration Screen	Scroll through TSP options in edit mode, Scroll through numbers in Number entry or Scroll through menu screens

4.3.5 Calibrate gauge screen

When the Calibrate Gauge screen is selected, the Gauge LED and the CAL LED are lit together. The numeric display is blank. The Calibrate Gauge menu is not available for gauges which do not support calibration.

When the ENTER key is pressed the action depends on gauge type:

WRG or APGX: The calibration command is sent to the gauge and the display shows "CALd" for 3 seconds.

ASG: The calibration functions as a zero offset adjustment. The pressure currently displayed is saved as the zero offset and is subtracted from all future readings. The display shows "CALd" for 3s to confirm the action. You can cancel the offset adjustment by pressing the ENTER key again. The display shows "OFF" for 3s to confirm that the offset adjustment has been removed.

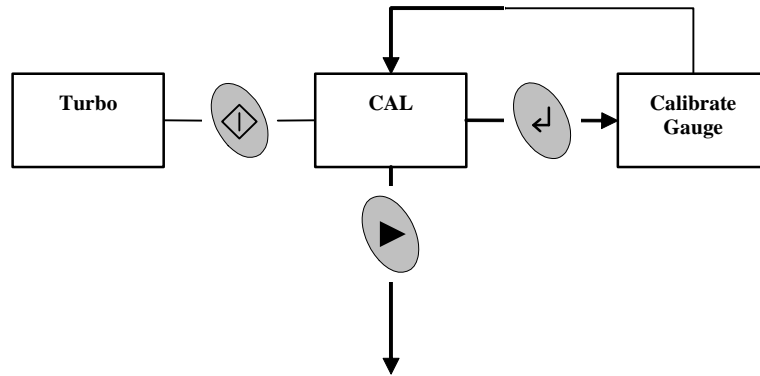

4.3.5.1 Calibrate screen key actions

Keys	Short Press	Long Press
START	Go to Turbo Screen	-
ENTER	Calibrate gauge	-
NEXT	Go to Units screen	Scroll through menu screens

4.3.6 Units screen

When the Units screen is selected, the menu LEDs are unlit and the currently selected Units LED is lit. The numeric display is blank.

To change the units press the ENTER key and use the NEXT key to choose between mbar, Torr, Pa and voltage. Press the ENTER key again to confirm the selection. Note that when voltage is selected the display shows " 0.000".

When the units are changed, the set-point values will be converted to the new units. For example, if a set-point threshold is entered as 1.0×10^{-3} mbar and the units are changed to Torr, then the value will be displayed as 7.5×10^{-4} Torr.

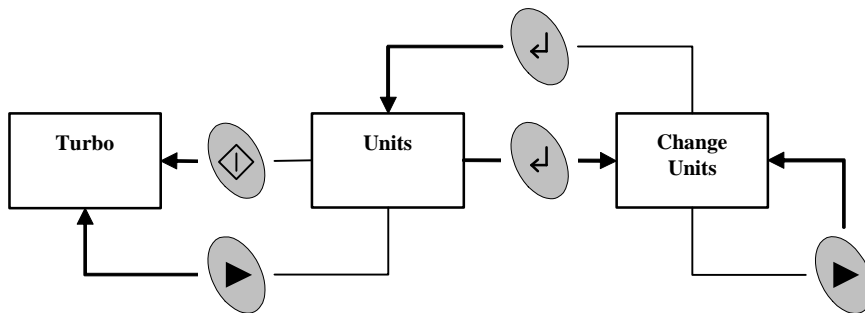

4.3.6.1 Units screen key actions

Keys	Short Press	Long Press
START	Go to Turbo Screen	-
ENTER	Enter edit mode, or confirm selection	-
NEXT	Next Units option, or go to Turbo screen	Scroll through Units in edit mode, or Scroll through menu screens

4.4 Gas-ballast control (E2M1.5)

Use the gas-ballast control (Figure 1, item 1) to change the amount of air (or inert gas) introduced into the low vacuum stage of the pump. Use of the gas-ballast will prevent the condensation of vapours in the pump; the condensates would contaminate the oil.

Use the gas-ballast control closed:

- to achieve ultimate vacuum
- to pump dry gases.

Turn the gas-ballast control six turns anti-clockwise to open it fully. Use the gas-ballast control open:

- to pump high concentrations of condensable vapour
- to decontaminate the oil.

When you operate the pump with the gas-ballast control open, there will be an increased rate of oil loss from the pump.

4.5 Electrical supply failure



WARNING

If the power supply fails when the pump is running, the impeller could continue to spin for approximately 10 minutes. The control circuit may not give any indication that the impeller is still running.

If the electrical supply to the T-Station fails when the Turbo pump is rotating, the motor of the pump is used as a generator. The regenerated power is used to maintain the control system and the display.

As the pump rotational speed decreases, the motor's ability to generate power also decreases until it is no longer able to maintain power to the control system. This will occur at speeds below 50% full rotational speed. Therefore you will not have any indication about pump rotational speed, yet the impeller may still be turning.

When the power is reinstated after a power failure, the behaviour of the T-Station will depend on the length of time the pump was without power: if the power is reinstated before regenerative power has ceased the system will re-start; if the power is reinstated after regenerative power has ceased the system will not re-start.

5 Maintenance

5.1 Safety



WARNING

Obey the safety instructions given below and take note of appropriate precautions. If you do not, you can cause injury to people and damage to equipment.

- When you refer to a manual supplied as a Supplementary Publication, you must obey all of the WARNING and CAUTION instructions in the manual.
- A suitably trained and supervised technician must maintain the T-Station.
- Allow the pumps to cool to a safe temperature before you start maintenance work.
- Check that all the required parts are available and of the correct type before you start work.
- Ensure that the maintenance technician is familiar with the safety procedures which relate to the products pumped. Wear the appropriate safety-clothing when you come into contact with contaminated components. Dismantle and clean contaminated components in a fume-cupboard.
- Isolate the T-Station and other components in the system from the electrical supply so that they cannot be operated accidentally.
- Do not reuse O-rings and Co-Seals if they are damaged.
- Dispose of components, grease and oil safely (refer to [Section 6](#)).
- Protect sealing-faces from damage.
- Leak-test the system after maintenance and seal any leaks found if you have disconnected any vacuum or exhaust pipeline connections.

5.2 Maintenance plan



WARNING

If for any reason the turbo pump is removed from the T-Station platform, it is important to retain and re-use the same fixing screws. If you have lost or cannot re-use any of these screws, you must use the following type M5 X 12 mm CAP HD high tensile class 12.9. If you fail to follow this warning and the turbo pump seizes, the stored energy in the turbo pump may cause some or all of the screws to fail, this may result in the turbo pump being ejected from the T-Station base.

The following documents list the minimum maintenance operations necessary to maintain the T-Station in normal use.

Diaphragm pump	XDD1	A746-02-885
Rotary vane pumps	E2M0.7 / E2M1.5	A371-32-880
Turbomolecular pumps	EXT75DX / EXT255DX	B722-40-880

More frequent maintenance may be necessary if the T-Station has been used to pump corrosive or abrasive gases and vapour. If necessary, adjust the maintenance plan according to your experience.

5.3 Inspect the hoses, pipelines and connections

1. Inspect all of the electrical connections and check that they are secure. Tighten any loose connections.
2. Inspect all of the electrical cables and check that they are not damaged and have not overheated. Replace or repair any damaged or overheated cable.
3. Inspect all of the vacuum and exhaust connections and check that they are secure. Tighten any loose connections.
4. Inspect all of the vacuum and exhaust pipelines and check that they are not corroded or damaged and that they do not leak. Replace or repair any corroded or damaged component and seal any leaks found.

5.4 Fault-finding

For additional information about fault-finding of the pumps used on your T-Station, refer to [Section 1.2.2](#)

Table 9 - Fault finding

Symptom	Check	Action
The T-station has failed to start	Has the electrical supply fuse blown? Is the operating voltage correct?	If so, replace the fuse. Refer to Section 2.3 for the correct fuse rating. Check your voltage supply matches the T-Station voltage requirements. Refer to the electrical rating label located at the rear of the T-Station.
Ultimate pressure cannot be reached	Is the pressure limited by water vapour? Are any of the vacuum gauges contaminated? Is the pumping speed insufficient (due to poor conductance between the pump and the gauge or too large a chamber)? Is the backing pressure too high? >10 mbar (1×10^3 Pa) To check, use a vacuum gauge directly on the turbo pump inlet (no volume) and run the backing pump only. Is the high vacuum area of the system contaminated? Check the rest of your system for leaks and contamination. Remove the pump from the system and test the ultimate pressure of the pump alone.	Bake the chamber or run the system for a duration until the vacuum improves. If so, clean or replace them. Increase the conductance or reduce the volume. If so, check the backing pipeline for leaks. The backing pump may need servicing. If so, clean the high vacuum system. If found, repair the leaks and clean the contamination. If inlet pressure is poor, check the pump for contamination and refer to Section 5 of the turbo pump manual. Leak-test the pump. If the leak rate $>1 \times 10^{-7}$ mbar l s ⁻¹ (1×10^{-5} Pa l s ⁻¹) contact your supplier or Edwards.

Table 9 - Fault finding (continued)

Symptom	Check	Action
The backing pump is noisy	Refer to the fault finding section of the Backing pump manual. See Section 1.2.2.	
The backing pump is leaking oil		
The turbo pump is very noisy or there is excessive vibration or both	Refer to the fault finding section of the Turbo manual. See Section 1.2.2.	

5.5 Error numbers

If an error is detected by the controller the display will show "Err" followed by a number. Refer to the table below for a description of the error together with likely causes and suggested remedies.

Table 10 - Error numbers

Error Number	Meaning	Possible cause/remedy
Controller errors		
1	EEPROM error	The internal EEPROM checksum has failed. All user settings will revert to the factory default.
2	ID reference error	The reference used for identifying gauges is incorrect. Please remove all gauge connection, turn the electrical supply off and on, and wait for 30 seconds before connecting gauges.
Gauge errors		
11	Gauge voltage too high	The voltage from a gauge is too high. The gauge may be defective.
12	Gauge voltage too low	The voltage from a gauge is too low. The gauge may be defective.
21	WRG Pirani failure	Errors specific to WRG. Please refer to the WRG manual for details. Press the ENTER key to clear the error from the display once the fault has been corrected.
22	WRG magnetron short	
23	WRG striker fail	
24	WRG magnetron not struck	
25	APGX filament failure	Errors specific to APGX. Please refer to the APGX manual for details. Press the ENTER key to clear the error from the display once the fault has been corrected.
26	APGX cal err	
27	APGXH tube not fitted	
Pump errors		
41	Turbo pump fault	Inspect the LEDs on the turbo pump podule for status information. For more detailed fault codes, press and hold the ENTER key (whilst Err41 is showing) to display the turbo pump system status word. The lower 16 bits of the status word are displayed in hexadecimal. Press the START / STOP key to clear the error message. Refer to the instruction manual of the turbo pump for detailed fault-finding.

5.6 Factory default settings

If you need to return the T-Station to the factory default settings follow these steps:

1. Remove the mains power from the T-Station
2. Press the NEXT key and hold it down whilst you re-apply mains power. Continue holding down the NEXT key until "Err01" is displayed.
3. Remove and re-apply mains power. The factory defaults will now be set.

6 Storage and disposal

Note: We recommend that you avoid long-term storage of the T-Station. If you will store the system for several months, refer to the Supplementary Publications in [Section 1.2.2](#) for storage condition of the pump combination you have installed on your T-Station.

6.1 Storage

Use the following procedure to store the T-Station:

1. Shut down the T-Station as described in [Section 4.3.1.2](#).
2. Isolate the T-Station from the electrical supply and disconnect it from the vacuum system.
3. Drain the oil from the backing pump (only applicable to the E2M1.5 rotary vane pump) as described in the instruction manual, (refer to [Section 1.2.2](#)).
4. Place protective covers over the inlet and outlet-flanges.
5. For the fastest pump-down after the T-Station is re-installed, seal the turbomolecular pump inside a plastic bag together with a suitable desiccant.
6. Store the T-Station in cool, dry conditions until required for use.

6.2 Disposal

Dispose of the T-Station and any components safely in accordance with all local and national safety and environmental requirements.

Particular care must be taken with components which have been contaminated with dangerous process substances.

For instruction on draining the oil from the E2M1.5 rotary vane pump refer to the instruction manual for the pump.

Rotary vane pumps

E2M0.7 / E2M1.5

A371-32-880

7 Spares and accessories

7.1 Introduction

Edwards products, spares and accessories are available from Edwards companies in Belgium, Brazil, Canada, France, Germany, Hong Kong, Italy, Japan, Korea, Switzerland, United Kingdom, U.S.A. and a worldwide network of distributors. The majority of these centres employ Service Engineers who have undergone comprehensive Edwards training courses.

Order spare parts and accessories from your nearest Edwards company or distributor. When you order, state for each part required:

- Model and Item Number of your equipment
- Serial number (if any)
- Item Number and description of the part.

Fit accessories as described in the Supplementary Publications and in the instruction manual supplied with the accessory.

7.2 Spares

The spares available for the turbo pump and backing pumps are listed in the CD instruction manuals supplied with your equipment.

Pump spares:

Turbomolecular pumps	EXT75DX / EXT255DX	B722-40-880
Diaphragm pump	XDD1	A746-02-885
Rotary vane pumps	E2M0.7 / E2M1.5	A371-32-880

7.3 Accessories

7.3.1 TAV vent-valve and vent-port adaptor (for DX turbo pump)

A solenoid-operated vent-valves is available for system venting. The valve is a 24 V d.c., normally-open and can be driven by the turbo pump podule. The solenoid-valve is fitted in place of the manual-valve, or alternatively can be fitted with an adaptor (supplied with the valve) and can be used with any suitable NW10 flanged port on your vacuum system.

Product	Item Number
TAV5 vent-valve	B580-66-010

7.3.2 Outlet mist filter (for E2M1.5 rotary vacuum pump)

The outlet mist filter separates and traps oil droplets in the pump outlet to prevent oil mist discharge.

Product	Item Number
EMF3 Outlet mist filter	A462-20-000

For all other Accessories such as Gauges, Active cables and Mains leads, refer to the T-Station ordering information in the Edwards product catalogue.

Index

A

- Active gauge connector pin-out7
- ASG range select 20

B

- Bench-top fixing 12

C

- Calibrate gauge screen 23
- Calibrate screen key actions 24
- Cautions1
- Checklist of components 11
- Commissioning the installation 16
- Components of the T-Station3
- Configure the T-Station 14
- Connect the electrical supply 14
- Connect the T-Station to your vacuum system 13
- Connect to your exhaust extraction system 13
- Connecting a gauge 20
- Connecting a vacuum gauge 15
- Control panel description 17

D

- Description2

E

- Electrical connections4
- Electrical data7
- Electrical supply failure 25
- Error numbers 28

F

- Factory default settings 29
- Fault finding 27
- Fault-finding 27
- Fill the rotary pump with oil 12
- Front panel display 17
- Front panel symbols and their functions 17

G

- Gas-ballast control (E2M1.5) 25
- Gauge ON/OFF control 20
- Gauge screen 20
- Gauge screen key actions 20
- General4

I

- Inspect the hoses, pipelines and connections 27
- Installation 11
- Introduction1

L

- Locate the T-Station 12

M

- Maintenance 26
- Maintenance plan 26
- Materials exposed to gases pumped9
- Menu items 17
- Menu structure 18

N

- Normal/abnormal operation4
- Number entry mode 22

O

- Operating and storage data4
- Operation 17

P

- Pin connections for an 8-way RJ456
- Pumping media8

S

- Safety 11, 26
- Scope and definitions1
- Spares and accessories 31
- Start up 17
- Starting the pumps 19
- Stopping the pumps 19
- Storage and disposal 30

T

- TAV vent-valve and vent-port adaptor (for DX turbo pump) 31
- Technical data4
- TSP screen key actions 23
- T-Station technical data9
- Turbo pump connector pin-out6
- Turbo pump delay 14
- Turbo screen 19
- Turbo screen key actions 19
- Turbo set point-screen 21

U

- Units screen 24
- Units screen key actions 24
- Unpack and inspect 11

V

- Vent gas specification and vent control9
- Vent gas specification and vent control data9

Index

Vent valve screen 21
Vent valve screen key actions 21

W

Warnings1