

Instruction Manual

nEXT Pump Accessories



Chemtech Scientific provides access to this content as a courtesy.
We do not own the content contained in this document.
All rights and credit go directly to its rightful owners.
www.chemtechsci.com
Call us at: 484-424-9415



This page has been intentionally left blank.

Contents

Section	Page
1 Introduction	1
1.1 Scope and definitions	1
1.2 Installation and operation safety	2
2 BX bakeout band	5
2.1 Description	5
2.2 Technical data	5
2.3 Installation	6
2.3.1 Unpack and inspect	6
2.3.2 Fit the BX bakeout band to the pump	6
2.3.3 Electrical connection to a TIC relay box	6
2.3.4 Electrical connection to an independent electrical supply	6
2.4 Operation	7
3 ACX nEXT Air Coolers	9
3.1 Description	9
3.2 Technical data	9
3.3 Installation	9
3.3.1 Unpack and inspect	9
3.3.2 Side (or Radial) mounting	9
3.3.3 Axial mounting	11
3.3.4 Combined radial and axial mounting	11
3.4 Electrical connection	13
3.4.1 Power supply requirements	13
3.5 Operation	14
4 TAV vent-valve	15
4.1 Description	15
4.2 Technical data	16
4.3 Installation	17
4.3.1 Unpack and inspect	17
4.3.2 Fit the TAV vent-valve to the pump	17
4.3.3 Electrical connection	18
4.4 Operation	19
5 Inlet-screens	21
5.1 Description	21
5.2 Technical data	21
5.3 Installation	21
5.3.1 Unpack and inspect	21
5.3.2 Fit or remove the inlet-screen	22
6 PRX10 purge-restrictor	25
6.1 Description	25
6.2 Technical data	25
6.3 Installation	25
6.3.1 Unpack and inspect	25
6.3.2 Fit the purge-restrictor	25
6.4 Operation	26
6.4.1 General	26
6.4.2 Calibration of the PRX10 purge-restrictor for different purge gases	26

7	Vent-port adaptor	29
7.1	Description	29
7.2	Technical data	30
7.3	Installation	30
7.3.1	Unpack and inspect	30
7.3.2	Connect the vent-port adaptor	30
8	VRX vent-restrictor	31
8.1	Description	31
8.2	Technical data	31
8.3	Installation	31
8.3.1	Unpack and inspect	31
8.3.2	VRX vent-restrictor selection	31
8.3.3	Fit the vent-restrictor	31
9	WCX water-cooler	33
9.1	Description	33
9.2	Technical data	33
9.3	Installation	33
9.3.1	Unpack and inspect	33
9.3.2	Fit the water-cooler to the pump	33
9.4	Operation	34
10	nEXT Interface Cable	35
10.1	Description	35
10.2	Technical data	35
10.3	Installation	35
10.3.1	Unpack and inspect	35
10.3.2	Fit the interface cable to the pump	35
10.4	Operation	36
11	Maintenance	37

For return of equipment, complete the HS Forms at the end of this manual.

Illustrations

Figure		Page
1	Accessories for nEXT pumps - general view (nEXT 240D pump shown)	3
2	Accessories for nEXT pumps -general view continued (nEXT240D DN100CF shown)	4
3	ACX nEXT air cooler installation, alternative mounting positions	10
4	ACX nEXT radial and axial air cooler installation	12
5	nEXT connector plug and socket	14
6	TAV vent-valve dimensions (mm)	16
7	Fitting the TAV vent-valve	17
8	TAV vent-valve connections	19
9	Integral mesh centring ring inlet-screen	22
10	Mesh inlet-screen	23
11	PRX10 purge-restrictor	27
12	Vent-port adaptor	29
13	Extended vent-port adaptor	29
14	VRX vent-restrictor	32
15	WCX water-cooling	34
16	nEXT interface cable	36

Tables

Table	Page
1 BX bakeout band technical data	5
2 ACX nEXT Air Cooler technical data	9
3 ACX nEXT air cooler power requirements	13
4 TAV vent-valve technical data	16
5 Inlet-screens technical data	21
6 PRX10 purge-restrictor technical data	25
7 Nitrogen flow rate through the PRX10 purge-restrictor	26
8 Vent-port adaptor technical data	30
9 Extended vent-port adaptor technical data	30
10 Vent-restrictor technical data	31
11 WCX water-cooler technical data	33
12 nEXT interface cable technical data	35

Associated publications

Publication title	Publication number
Vacuum pump and vacuum system safety	P400-40-100

This page has been intentionally left blank.

1 Introduction

1.1 Scope and definitions

This manual provides installation, operation and maintenance instructions for the Edwards range of accessories for the nEXT pump range.

The accessories are shown in [Figure 1](#) and [2](#). The Item Numbers for the accessories are listed in the appropriate sections. You must use the accessories as specified in this manual. Read this manual before you install accessories onto your nEXT pump.

Important safety information is highlighted as WARNING and CAUTION instructions; you must obey these instructions. The use of WARNINGS and CAUTIONS is defined below.



WARNING

Warnings are given where failure to observe the instruction could result in injury or death to people.

CAUTION

Cautions are given where failure to observe the instruction could result in damage to the equipment, associated equipment and process.

Throughout this manual, page, figure and table numbers are sequential.

The units used throughout this manual conform to the SI international system of units of measurement. When flow rates are specified, the abbreviation 'sccm' is used to mean 'standard $\text{cm}^3 \text{min}^{-1}$ ': this is a flow of $1 \text{ cm}^3 \text{min}^{-1}$ at an ambient temperature of $0 \text{ }^\circ\text{C}$ and a pressure of 1013 mbar ($1.013 \times 10^5 \text{ Pa}$).

In accordance with the recommendations of EN61010, the following warning labels may appear on the pump or its accessories:



Warning - refer to accompanying documentation.



Warning - risk of electric shock.



Warning - hot surfaces.

1.2 Installation and operation safety



WARNING

You must use the procedures described in this manual to install your accessory, and you must obey all safety instructions and take note of all appropriate precautions. If you do not, you can damage the accessory or other equipment and can cause injury to people.



WARNING

The user of the nEXT pump system is responsible for the safe operation and monitoring of the system.



WARNING

Before you install the accessory, ensure that you switch off the pump and isolate the controller/podule as described below.

Before you install your accessory, you must:

- Switch off the nEXT pump and wait until the pump has stopped rotating.
- Isolate the pump controller from the electrical supply.

Figure 1 - Accessories for nEXT pumps - general view (nEXT 240D pump shown)

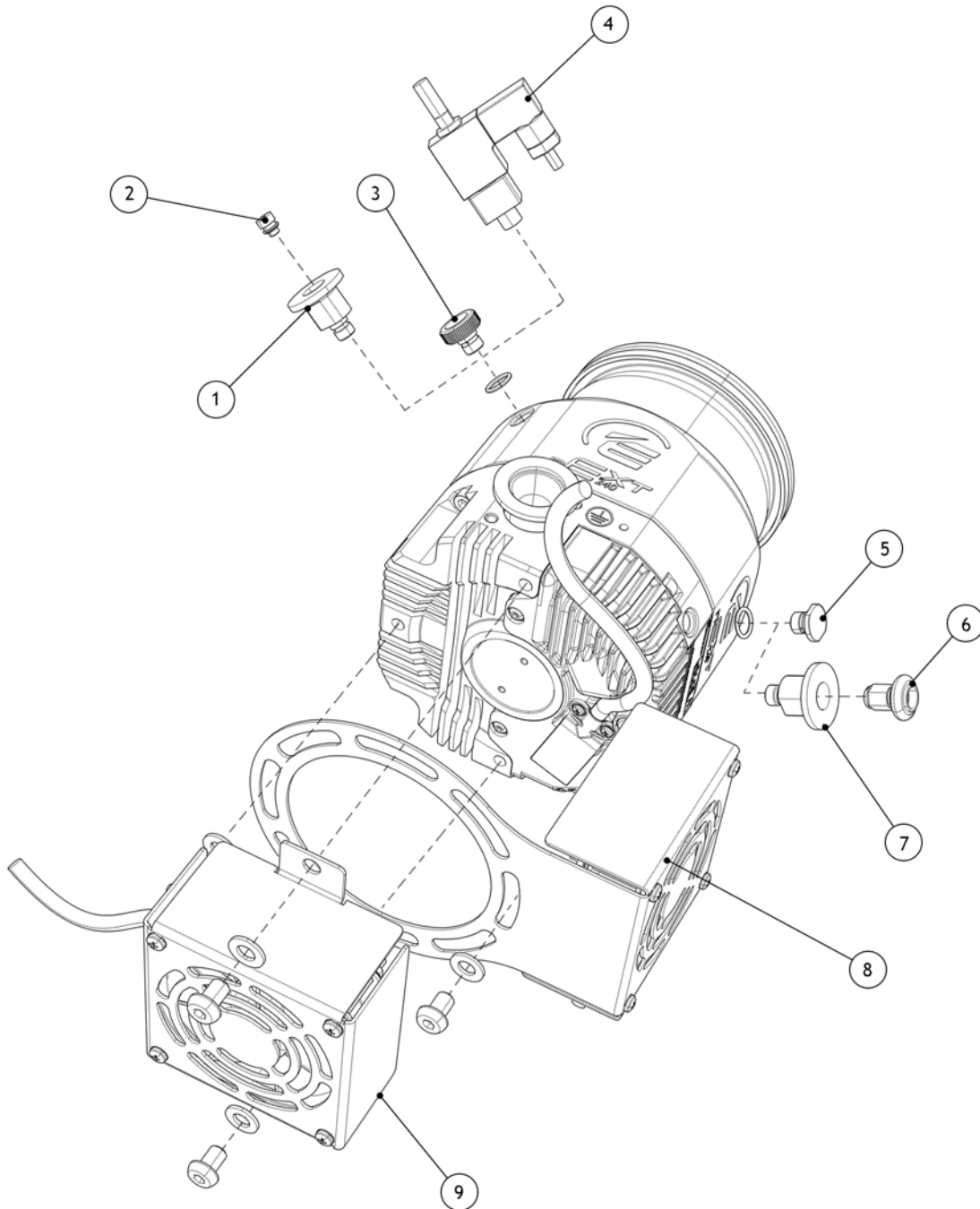

- | | |
|-------------------------------|---------------------------------|
| 1. DN10NW Adaptor | 6. PRX purge-restrictor |
| 2. VRX vent-restrictor | 7. DN10NW Adaptor |
| 3. Manual vent-valve (fitted) | 8. ACX nEXT air cooler (Radial) |
| 4. TAV Solenoid vent-valve | 9. ACX nEXT air cooler (Axial) |
| 5. Purge plug (fitted) | |

IA/041/05/09

Figure 2 - Accessories for nEXT pumps -general view continued (nEXT240D DN100CF shown)

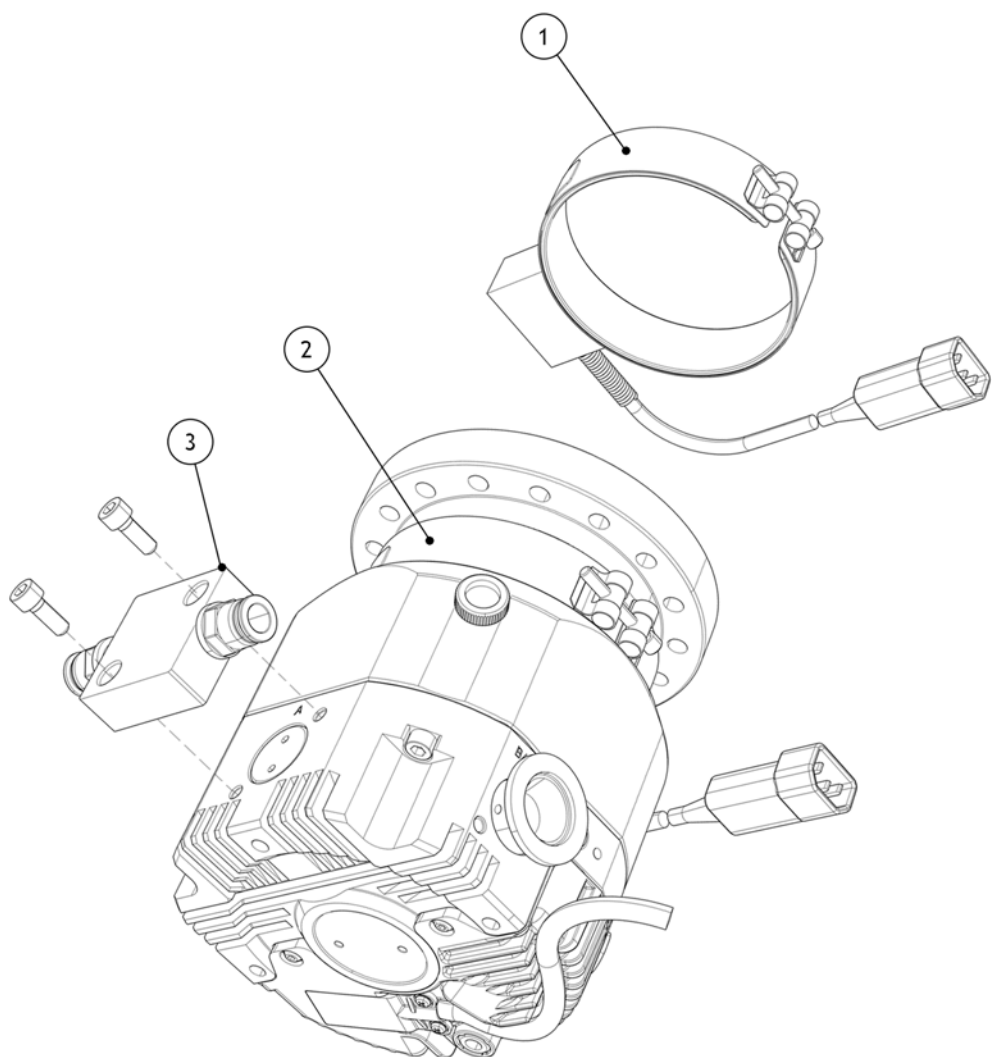

IAI/016/05/09

- 1. BX 250 Bake out band (DN100CF envelope shown)
- 2. BX 250 Bake out band position
- 3. WCX Water cooling accessory

2 BX bakeout band

2.1 Description

You can fit an Edwards BX bakeout band to a nEXT pump to increase the rate of degassing of the pump body, to achieve faster pump down and lower ultimate pressure. You should only fit a BX bakeout band to CF flanged pumps intended for use at ultra high vacuum.

BX bakeout bands are available for use with electrical supplies of 110 or 240V a.c., from a rear panel socket on a TIC relay box, or from any suitable electrical supply.

2.2 Technical data

Table 1 - BX bakeout band technical data

Electrical supply	110 to 120 V a.c., 50/60 Hz or 200 to 240 V a.c., 50/60 Hz		
Cable length	3 m		
Termination	3-pin IEC reverse configuration plug		
Typical operating temperature	80 °C (measured on the pump envelope above the bakeout band)		
Pollution degree	EN61010 Part 1, Category 2		
Equipment type	Fixed equipment for indoor use only		
	BX250	BX300	BX450
Approximate mass (kg)	0.55	0.65	0.70
Minimum diameter (mm)	119	140	140
Width of band (mm)	30	20	40
Input power (W)	60	80	80
Fuse rating			
110 to 120 V	1.0 A	1.0 A	1.0 A
200 to 240 V	0.5 A	0.5 A	0.5 A
Item Numbers			
Model	To fit pump		Item Number
BX250 110 V	nEXT240		B580-52-041
BX300 110 V	nEXT300		B580-52-048
BX450 110V	nEXT400		B580-52-043
BX250 240 V	nEXT240		B580-52-061
BX300 240 V	nEXT300		B580-52-068
BX450 240 V	nEXT400		B580-52-063

2.3 Installation

2.3.1 Unpack and inspect

Remove all packing materials and protective covers and check the BX bakeout band.

If the BX bakeout band is damaged, notify your supplier and the carrier in writing within three days; state the Item Number of the BX bakeout band together with your order number and your supplier's invoice number. Retain all packing materials for inspection. Do not use the BX bakeout band if it is damaged.

2.3.2 Fit the BX bakeout band to the pump



WARNING

Before you install the accessory, ensure that the pump is switched off and isolated as described below.

Refer to [Figure 2](#).

1. Switch off the pump, isolate the pump controller from the electrical supply, and wait until the pump has stopped rotating.
2. Fit the BX bakeout band over the pump body below the inlet flange at the position shown by [Figure 2](#).
3. Tighten the clamping screw.

2.3.3 Electrical connection to a TIC relay box

Refer to the TIC relay box instruction manual for information on how to fit the correct fuse, and how to connect the bakeout band to the TIC relay box.

2.3.4 Electrical connection to an independent electrical supply

If necessary, you can connect the BX bakeout band directly to an appropriate electrical supply.

Always ensure that the electrical supply to the bakeout band is interlocked so that it is automatically switched off whenever the nEXT pump operates below normal speed. Check that the rating of the fuse fitted within your electrical supply corresponds to the fuse rating on the BX bakeout band.

2.4 Operation



WARNING

Do not operate the BX bakeout band when it is not installed on a pump. Without the cooling effect of the pump-body, the temperature of the band can rise to 300 °C with the danger of insulation breakdown and fire.



WARNING

Do not touch the BX bakeout band when it is switched on, as it can get very hot during operation.

CAUTION

When using the bakeout heater accessory, water cooling should always be used. If using the heater accessory in combination with baking heaters on the vacuum system, the pump inlet flange temperature should not exceed 80°C. Generally this is ensured by allowing the mating flange on the system to reach a maximum of 120°C.

When you use the bakeout band, ensure that there is adequate cooling for the pump and adequate ventilation for the bakeout band.

If you have connected the bakeout band to a TIC relay box, refer to the TIC instruction manual for instructions on how to use the TIC to control the operation of the bakeout band.

This page has been intentionally left blank.

3 ACX nEXT Air Coolers

3.1 Description

The ACX nEXT air cooler is an enclosed 24 V d.c. motor electric fan and a fixing bracket assembly which can be easily fitted to the nEXT range of pumps via bolt holes in the base of the pump.

The ACX nEXT air coolers are available for both radial and axial mounting. It is possible to use both variants simultaneously if so desired and space allows. TICs can provide power for one fan only.

3.2 Technical data

Table 2 - ACX nEXT Air Cooler technical data

Electrical supply	20 to 28 V d.c.
Cable cores	Red (+20 - 28 V) Black (0 Volts return) Yellow and Green (screen)
Pollution degree	EN61010 Part 1 Category 2
Power consumption	2.7 Watts
Noise emissions	39 dBA (per fan)

3.3 Installation

3.3.1 Unpack and inspect

Remove all packing and materials and protective covers and check the ACX air cooler.

If the ACX air cooler is damaged, notify your supplier and the carrier in writing within three days; state the Item Number of the ACX air cooler together with your order number and your supplier's invoice number. Retain all packing materials for inspection. Do not use the ACX air cooler if it is damaged.

3.3.2 Side (or Radial) mounting



WARNING

Before you install the accessory, ensure that you switch off and isolate the pump.

Refer to [Figure 3](#) and [4](#).

1. Switch off pump; wait until the pump has stopped rotating. Isolate the pump drive from the electrical supply.
2. Remove the rubber mounting feet from the base of the pump.
3. Using 4 off M8 x 12 mm button head screws supplied. Fit the ACX radial air cooler mounting bracket to the base of the pump as shown on [Figure 4](#). Ensure the fixing screws are secure. To ensure the radial air cooler works most effectively it is recommended that the fan should be placed directly opposite the pump drive, as shown in [Figure 4](#). This ensures adequate cooling of the nEXT drive. Alternative mounting positions are available as shown in [Figure 3](#).

Figure 3 - ACX nEXT air cooler installation, alternative mounting positions

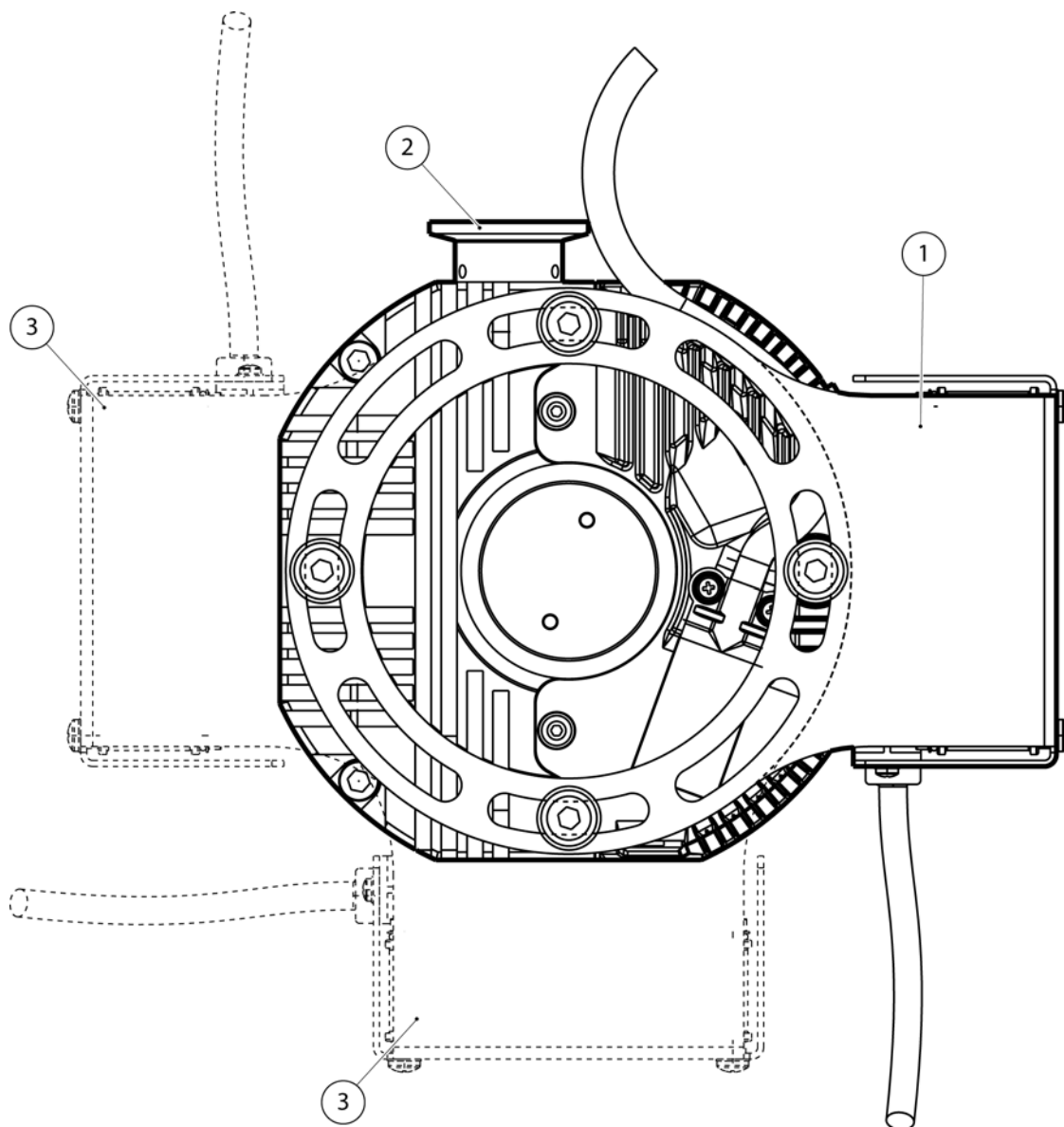

- 1. ACX nEXT Air cooler (recommended)
- 2. Pump outlet port
- 3. Alternative mounting position

3.3.3 Axial mounting



WARNING

Before you install the accessory, ensure that you switch off and isolate the pump.



WARNING

The axial air cooler does not have an internal guard and **MUST NOT** operate unless attached to the pump.

Refer to [Figure 4](#).

1. Switch off pump; wait until the pump has stopped rotating. Isolate the pump drive from the electrical supply.
2. Remove the rubber mounting feet from the base of the pump.
3. Using the M8 x 12 mm button head screws supplied, fit the ACX axial air cooler to the base of the pump as shown in [Figure 1](#). Ensure the fixing screws are secure.

3.3.4 Combined radial and axial mounting

Refer to [Figure 4](#).

Maximum pump cooling can be obtained with the simultaneous use of radial and axial cooling fans. The fan arrangements can be fitted as shown in [Figure 1](#).

1. Switch off pump; wait until the pump has stopped rotating. Isolate the pump drive from the electrical supply.
2. Remove the rubber mounting feet from the base of the pump.
3. Using the M8 x 12 mm button head screws supplied, fit the radial and axial air coolers to the base of the pump as shown in [Figure 1](#).

Figure 4 - ACX nEXT radial and axial air cooler installation

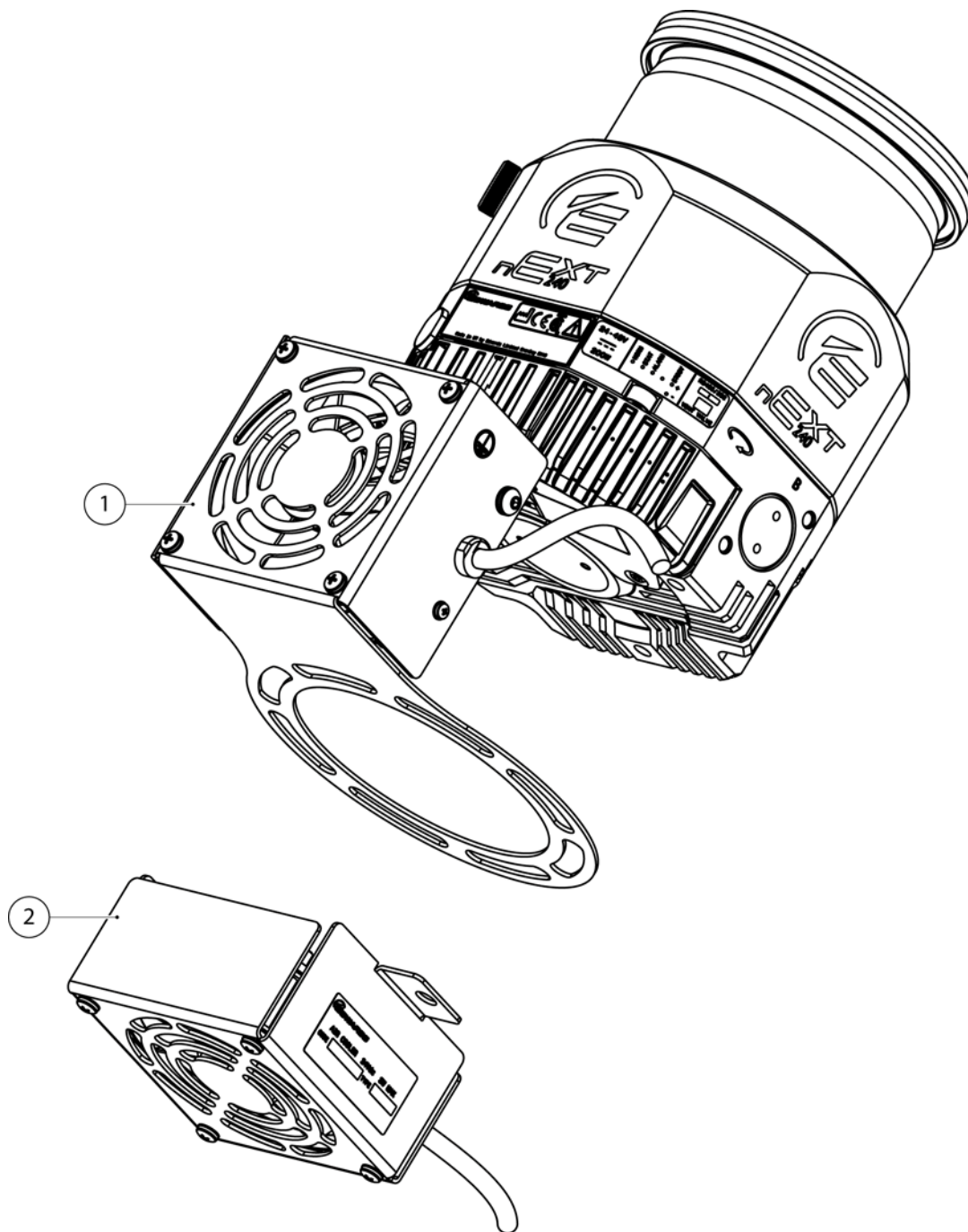

- 1. Axial air-cooler
- 2. Radial air-cooler

3.4 Electrical connection

CAUTION

Ensure that the electrical supply is correct. If it is not, you can damage the ACX air cooler.

CAUTION

Ensure that the power supply to the cooling accessory can be isolated in a fault condition if required.

The ACX air cooler requires a 24 V d.c. electrical supply. You can connect the ACX air cooler to a TIC (Turbo Instrument Controller), a suitable electrical supply or via the nEXT drive electronics.

With the air cooler powered via the nEXT drive electronics, the turbo pump will operate satisfactorily with any of the supply voltages specified in the pump product manual.

Note: Note: For combined use of both the axial and radial ACX air coolers, a TIC can be used to supply power to one air cooler only. A separate 24 V power supply is required to power the second air cooler.

It is recommended that you fit a separate earth (ground) conductor to the earth of the air cooler; use an un-insulated braid or a separate insulated green/yellow connector and use the M5 x 10 screw and shake-proof washer supplied (attached to the fan cowling) to secure the earth conductor to the air-cooler.

3.4.1 Power supply requirements

Table 3 - ACX nEXT air cooler power requirements

Part number	Description	Operation
B58053170	ACX nEXT RADIAL KIT 24 V WIRED	Powered via the nEXT drive electronics. See section 4.2
B58053175	ACX nEXT RADIAL KIT 24 V STD	Powered via the TIC or any suitable electrical power supply
B58053180	ACX nEXT AXIAL KIT 24 V WIRED	Powered via the nEXT drive electronics. See section 4.2.
B58053185	ACX nEXT AXIAL KIT 24 V STD	Powered via the TIC or any suitable electrical power supply

3.4.1.1 Connector socket

The nEXT turbo pump drive has a 3-way connector socket on the side of the pump as circled in [Figure 5](#). When you receive the pump, this connector may be concealed by a black protective cover. If you intend to use the connector, this cover should be removed by levering with a small screwdriver. A mating plug for this connector is supplied with the pump and the following fan assemblies are available which has a mating plug pre-wired:

- B58053170 ACX nEXT RADIAL KIT 24 V WIRED
- B58053180 ACX nEXT AXIAL KIT 24 V WIRED

Figure 5 - nEXT connector plug and socket

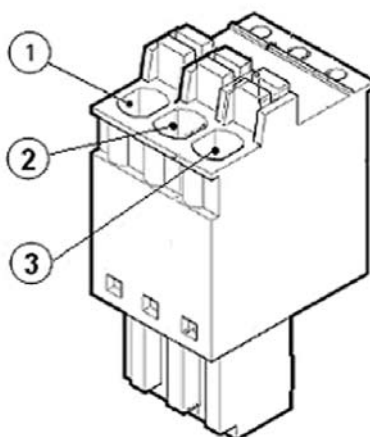

1. 24 V d.c. Out
2. Chassis
3. 24 V d.c. Rtn

3.5 Operation



WARNING

There is no guard on the outlet of the axial air cooler. Therefore, you must not operate the air cooler unless it is installed on the pump.

When operating the ACX air cooler, do not obstruct the fan inlet and ensure there is an adequate supply of cooling air. During operation, if the temperature of any surface of the pump is higher than 60 °C the pump is too hot and you must increase the cooling.

4 TAV vent-valve

4.1 Description

To maintain cleanliness of your vacuum system, we recommend that you vent the pump or vacuum system whenever you switch the pump off.

The TAV vent-valves are 24 V d.c. electrical-solenoid operated valves which you can use to vent your vacuum system with atmospheric air or dry nitrogen when you switch the nEXT pump off.

The TAV vent-valve is normally open when the solenoid is de-energised. In the case of a power failure, the vacuum system and pump will vent and the pump will slowly come to a halt.

Refer to [Figure 8](#). The TAV vent-valve is supplied with a sintered bronze inlet filter (1), a ruffled hose connector (7) and 3 metres of cable.

You can connect your dry nitrogen supply to the hose connector.

An NW10 adaptor ([Figure 8](#), item 3) is also supplied to convert the 1/8 inch BSP outlet connector ([Figure 6](#), item 2) of the TAV vent-valve for direct connection to your vacuum system.

The TAV vent-valve can be powered by the nEXT drive electronics, controlled from a TIC controller, or from any suitable electrical supply.

CAUTION

Correct venting is essential to prevent suck-back of hydrocarbon vapour present in the backing line - especially when using oil-sealed rotary vane pumps. To prevent suck-back when stopping the nEXT pump, always begin the venting sequence before the nEXT pump has slowed to 50% of normal rotational speed. Always introduce venting gas to the venting port or to the high vacuum inlet. Never vent to the backing line.

4.2 Technical data

Table 4 - TAV vent-valve technical data

	TAV5	TAV6
Maximum inlet pressure	1 bar gauge, 2×10^5 Pa	1 bar gauge, 2×10^5 Pa
Orifice diameter	0.5 mm	1.0 mm
Helium leak rate (valve closed)	$< 1 \times 10^{-8}$ mbar l s ⁻¹ $< 1 \times 10^{-6}$ Pa l s ⁻¹	$< 1 \times 10^{-6}$ mbar l s ⁻¹ $< 1 \times 10^{-4}$ Pa l s ⁻¹
Valve inlet-filter	Sintered bronze	Sintered bronze
Hose connector	Riffled nozzle for 4 mm bore tube	Riffled nozzle for 4 mm bore tube
Dimensions	See Figure 6	See Figure 6
Mass	0.08 kg	0.08 kg
Item Numbers	B580-66-010	B580-66-020
Configuration	Normally open	
Pollution degree	EN61010 Part 1, Category 2	
Equipment type	Fixed equipment for indoor use only	
Nominal electrical supply voltage	24 V d.c.	
Electrical supply voltage range	15 to 24 V d.c.	
Pull-in voltage	14 V d.c.	
Drop-out voltage	10 V d.c.	
Power consumption	1.8 W	
Cable type and length	2-core screened, unterminated, 3 m long	
Cable cores	Red (positive), black (negative)	
Valve electrical connector type	2 pole and earth (ground), miniature DIN	
Valve inlet-connection	M5 female	
Valve outlet-connection	1/8 inch BSP	

Figure 6 - TAV vent-valve dimensions (mm)

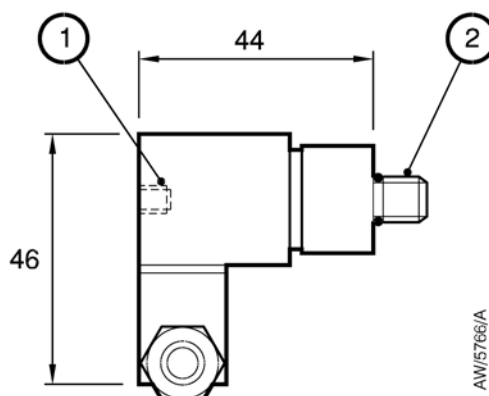

1. M5 female thread
2. 1/8 inch BSP male thread

4.3 Installation

4.3.1 Unpack and inspect

Remove all packing materials and protective covers and check the TAV vent-valve.

If the TAV vent-valve is damaged, notify your supplier and the carrier in writing within three days; state the Item Number of the TAV vent-valve together with your order number and your supplier's invoice number. Retain all packing materials for inspection. Do not use the TAV vent-valve if it is damaged.

4.3.2 Fit the TAV vent-valve to the pump



WARNING

Before you install the accessory, ensure that you switch off the pump and disconnect the power supply as described below.

CAUTION

When fitting the TAV vent-valve, apply torque to the steel body only. On no account should torque be applied to the solenoid body, failure to do so could damage the valve which may cause it to leak.

Figure 7 - Fitting the TAV vent-valve

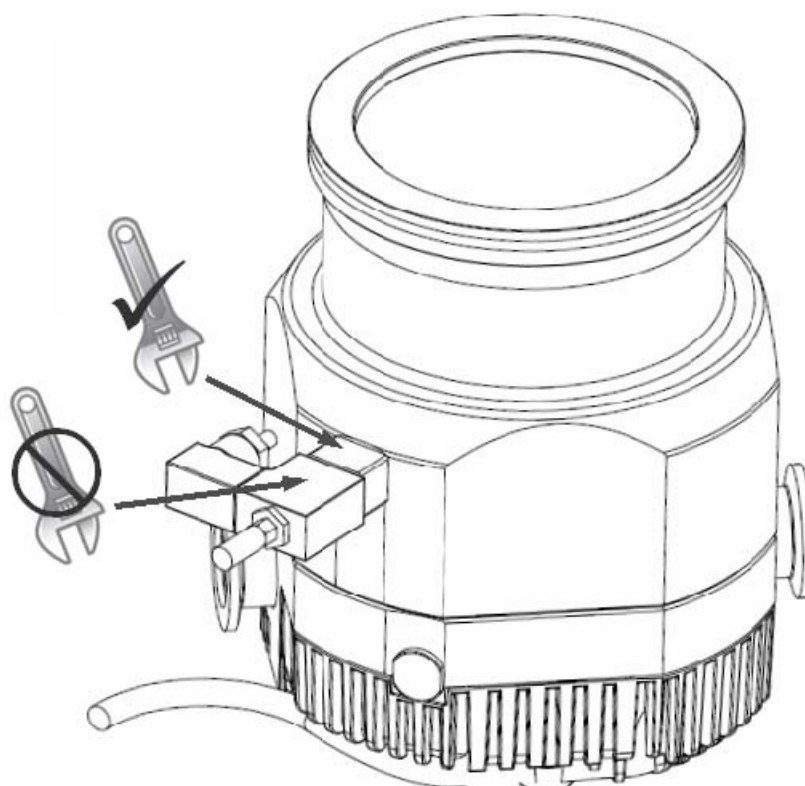

Refer to [Figure 1](#).

1. Switch off the pump, isolate the pump controller from the electrical supply, and wait until the pump has stopped running.
2. If your nEXT pump has a manual vent-valve, unscrew and remove it, then continue at step 4.
3. If your nEXT pump does not have a manual vent-valve, fit the vent-valve adaptor to a suitable NW10 flange on your pump or vacuum system.
4. Check that the TAV vent O-ring ([Figure 8](#), item 4) is fitted and screw the TAV vent-valve into the vent-valve adaptor or into the 1/8 inch BSP hole vacated by the manual vent-valve.
5. Connect your dry nitrogen or other inert gas supply pipeline to the M5 inlet ([Figure 8](#), item 2) or use the riffled hose connector ([Figure 8](#), item 7) supplied.
6. If you vent the pump with air, fit the sintered bronze inlet-filter ([Figure 8](#), item 1) to protect your system against the entry of dust.

4.3.3 Electrical connection

CAUTION

Ensure that the electrical supply is correct. If it is not, you can damage the TAV vent-valve.

The TAV vent-valve requires a 24 V d.c. electrical supply.

The nEXT pump includes drive electronics which provide facilities for regulated pulsed venting (see pump manual for details). This ensures that your vacuum system can be vented to atmosphere as rapidly as possible without damage to the pump.

Alternatively, you can connect the TAV vent-valve to a TIC (see TIC instruction manual for details) or your own electrical supply.

4.4 Operation

CAUTION

If you manually vent the pump when it is at full rotational speed and the rate of pressure rise is too high, the pump life may be reduced. When using the manual vent-valve supplied, we recommend that you either limit the vent or only open the vent-valve after the nEXT pump speed has fallen to 50% of full rotational speed. Do not vent the backing line as this may lead to contamination. If you vent into your vacuum system and use an oil sealed rotary backing pump, select a point upstream of the nEXT pump, to prevent oil back-streaming from the backing line.

Operation of the TAV vent-valve depends on how you have connected it:

- If you have connected the TAV vent-valve to the drive electronics of the nEXT pump; refer to the nEXT pump instruction manual.
- If you have connected the TAV vent-valve to a TIC: refer to the TIC instruction manual for operating instructions.
- If you have connected the TAV vent-valve to your own electrical supply, switch on the electrical supply to operate the vent-valve.

Figure 8 - TAV vent-valve connections

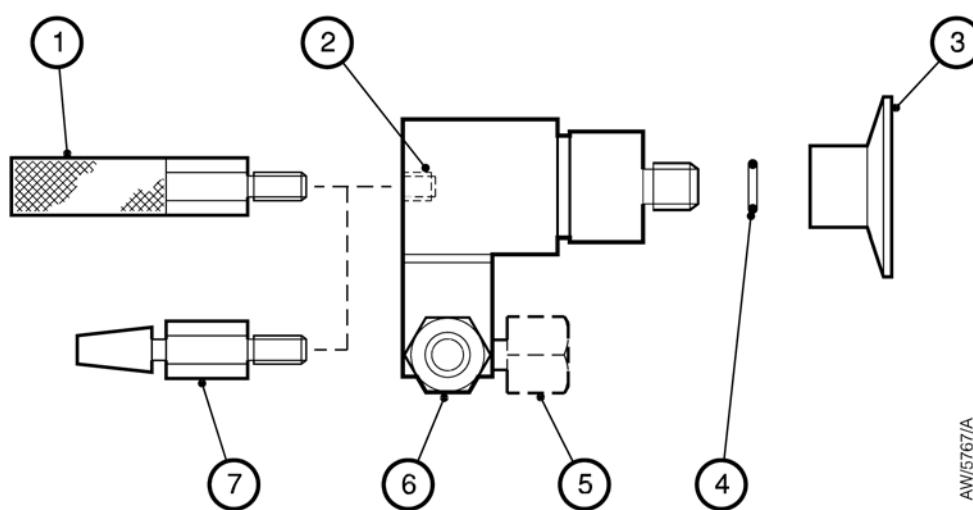

1. Air filter
2. Inlet-port
3. Vent-valve adaptor
4. O-ring

5. Alternative electrical supply connector position
6. Electrical supply connector
7. Hose connector

AW/5767/A

This page has been intentionally left blank.

5 Inlet-screens

5.1 Description

Inlet-screens are supplied with all new nEXT pumps. If you have a nEXT pump without an inlet-screen, we recommend that you fit an inlet-screen for additional safety. The only exception to this is the main port in the END faces of split flow pumps. Plastic covers must be retained on these variants until ready to install to minimise the risk of injury from impeller blades.

The inlet-screen prevents the entry of debris into the pump and also prevents people from coming into contact with the blades if the pump is switched on when it is disconnected from your vacuum system.

5.2 Technical data

Note: Refer to the pump instruction manual for details of performance reductions when an inlet-screen is fitted.

Table 5 - Inlet-screens technical data

Pump inlet flange size	Pump model	Item number
ISO100 coarse inlet-screen	nEXT240 / 300	B810-00-808
ISO100 fine inlet-screen	nEXT240 / 300	B810-00-809
ISO160 coarse inlet-screen	nEXT400	B800-00-825
ISO160 fine inlet-screen	nEXT400	B800-00-826
CF100 coarse inlet-screen	nEXT240 / 300	B800-00-821
CF100 fine inlet-screen	nEXT240 / 300	B800-00-822
CF160 coarse inlet-screen	nEXT400	B800-00-823
CF160 fine inlet-screen	nEXT400	B800-00-824

5.3 Installation

5.3.1 Unpack and inspect

Remove all packing materials and protective covers and check the inlet-screen.

If the inlet-screen is damaged, notify your supplier and the carrier in writing within three days; state the Item Number of the inlet-screen together with your order number and your supplier's invoice number. Retain all packing materials for inspection. Do not use the inlet-screen if it is damaged.

5.3.2 Fit or remove the inlet-screen



WARNING

Before you install the accessory, ensure that you switch off the pump and disconnect the power supply as described below.



WARNING

If you remove the inlet-screen, there will be a risk of injury from exposed sharp edges in the pump.

CAUTION

Do not remove the inlet-screen unless you can be sure that debris cannot fall into the pump. Debris which falls into the pump can seriously damage it.

1. Switch off the pump, isolate the pump controller from the electrical supply, and wait until the pump has stopped rotating.
2. Use the following appropriate procedure according to the type of inlet-screen.

5.3.2.1 Integral mesh centring ring inlet-screen

Refer to Figure 9.

- Locate the inlet-screen between the nEXT pump flange and the mating flange on your vacuum system chamber.

Figure 9 - Integral mesh centring ring inlet-screen

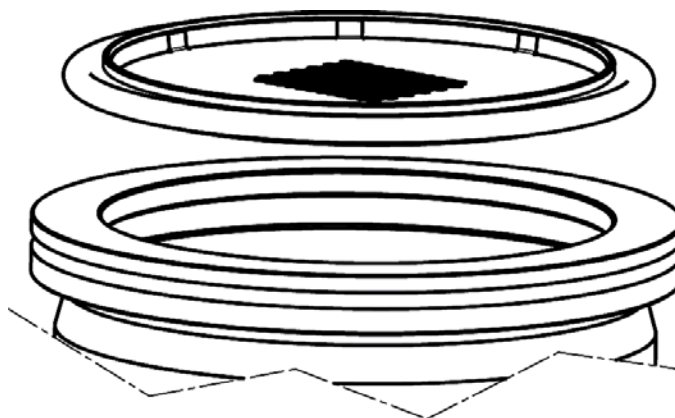

5.3.2.2 Mesh inlet-screen

Refer to Figure 10.

- Insert the mesh inlet-screen into the pump inlet as shown in Figure 10.

Figure 10 - Mesh inlet-screen

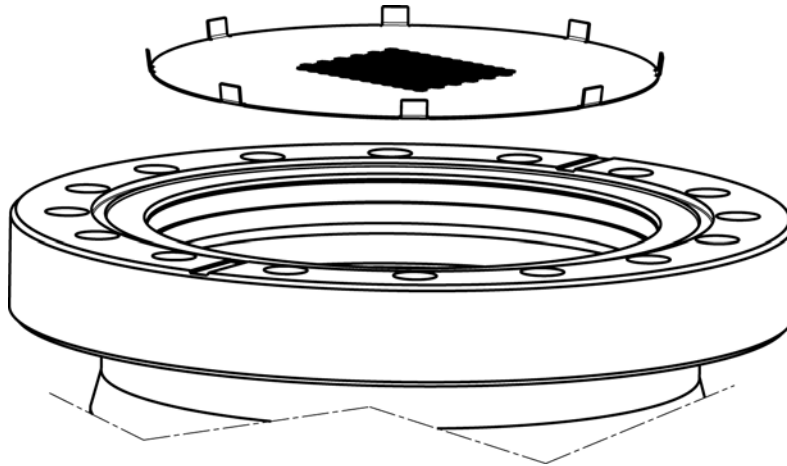

This page has been intentionally left blank.

6 PRX10 purge-restrictor

6.1 Description

The PRX10 purge-restrictor (shown in [Figure 11](#)) sets the purge gas flow rate.

The nEXT pump range has a purge port facility to allow you to purge the motor and bearing cavity with dry nitrogen or other inert gas.

Note: You will need a vent port adaptor (see [Section 7](#)) to fit the PRX10 purge-restrictor.

6.2 Technical data

Table 6 - PRX10 purge-restrictor technical data

Nominal nitrogen flow rate*	255 sccm, 0.42 mbar l s ⁻¹ , 42 Pa l s ⁻¹
Flange size	NW10
Item Number	B580-65-001

* At a supply pressure of 0 bar gauge (1 x 10⁵ Pa)

6.3 Installation

6.3.1 Unpack and inspect

Remove all packing materials and protective covers and check the PRX10 purge-restrictor.

If the PRX10 purge-restrictor is damaged, notify your supplier and the carrier in writing within three days; state the Item Number of the PRX10 purge-restrictor together with your order number and your supplier's invoice number. Retain all packing materials for inspection. Do not use the PRX10 purge-restrictor if it is damaged.

6.3.2 Fit the purge-restrictor



WARNING

Before you install the accessory, ensure that you switch off the pump and disconnect the power supply as described below.

CAUTION

Do not exert any sideways force on the purge-restrictor when you clamp it into place. If you do, you can damage the seal between the O-ring ([Figure 11](#), item 2) and the body of the purge-restrictor. If the seal is damaged, gas may leak through the seal and you will not be able to properly control gas flow into the pump.

Note: If you will use a purge gas other than nitrogen, you must calibrate the purge-restrictor (refer to [Section 6.4.2](#)) before you connect your purge gas supply.

1. Switch off the pump, isolate the pump controller from the electrical supply, and wait for the pump to stop rotating.
2. Remove the blank and clamp from the purge-port on the pump.

- Attach your purge gas supply pipeline (which must be terminated with an NW10 flange) to the purge-port with the PRX10 purge-restrictor in place of the normal NW10 centring-ring.
- Carefully secure the connection with the NW10 clamp.

6.4 Operation

6.4.1 General

The PRX10 purge-restrictor, as supplied, is adjusted to restrict the flow rate of dry nitrogen at a supply pressure of 0 bar gauge (1×10^5 Pa) to 25 sccm ($0.42 \text{ mbar l s}^{-1}$, 42 Pa l s^{-1}). You can increase the supply pressure to increase the flow rate; see [Table 7](#).

For most applications, you can use a nitrogen flow rate of 25 sccm ($0.42 \text{ mbar l s}^{-1}$, 42 Pa l s^{-1}) to 30 sccm ($0.5 \text{ mbar l s}^{-1}$, 50 Pa l s^{-1}). To do this, your nitrogen supply pressure must be 0.1 to 0.2 bar gauge (1.1×10^5 to 1.2×10^5 Pa). Do not exceed the maximum purge gas supply pressure given in the instruction manual supplied with your pump.

6.4.2 Calibration of the PRX10 purge-restrictor for different purge gases

The purge gas flow rate at a particular supply pressure will change if you use a different purge gas.

If you want to use a different purge gas, use the procedure below to adjust the flow rate.

- Fit the PRX10 purge-restrictor to the pump as described in [Section 6.3.2](#). Fit a calibrated mass flow meter between your purge gas supply and the PRX10 purge-restrictor.
- Switch on the backing pump to evacuate the nEXT pump and then turn on your purge gas supply.
- Monitor the indicated purge gas flow rate while you adjust the purge gas supply pressure. If you can achieve the required flow rate, you do not need to adjust the purge-restrictor; in this case, continue at Step 5 below.
- Refer to [Figure 11](#). If you cannot achieve the required flow rate, undo the locknut (3) on the purge-restrictor and use a small screwdriver to turn the adjustment screw (4) clockwise to decrease the flow rate, or anticlockwise to increase the flow rate. Tighten the locknut.
- Turn off your purge gas supply, remove the mass flow meter and connect your purge gas supply to the purge-restrictor.

Table 7 - Nitrogen flow rate through the PRX10 purge-restrictor

Nitrogen supply pressure			Nitrogen flow rate		
bar gauge	bar absolute	Pa	sccm	mbar l s ⁻¹	Pa l s ⁻¹
0.0	1.0	1.0×10^5	25	0.42	42
0.5	1.5	1.5×10^5	38	0.63	63
1.0	2.0	2.0×10^5	50	0.83	83
1.5	2.5	2.5×10^5	63	1	100
2.0	3.0	3.0×10^5	75	1.25	125
2.3	3.5	3.5×10^5	88	1.5	150
3.0	4.0	4.0×10^5	100	1.7	170

Figure 11 - PRX10 purge-restrictor

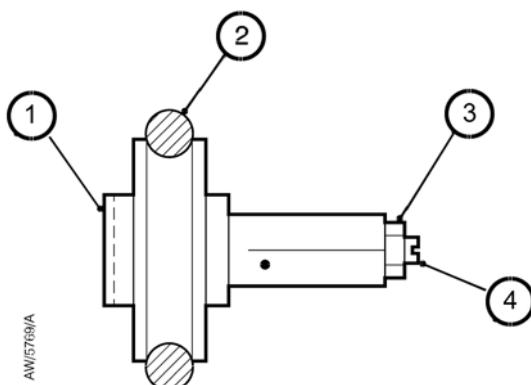

1. Filtered purge gas inlet to PRX10 purge-restrictor
2. O-ring
3. Locknut
4. Adjustment screw

This page has been intentionally left blank.

7 Vent-port adaptor

7.1 Description

The 1/8 inch BSP(P) male to NW10 vent-port adaptor can be used to convert the 1/8 inch BSP(P) female vent-port on all nEXT pumps to an NW10 flange. An alternative vent-valve to the TAV 5/6 or a vent pipeline may then be fitted to this flange. See Figure 12.

Figure 12 - Vent-port adaptor

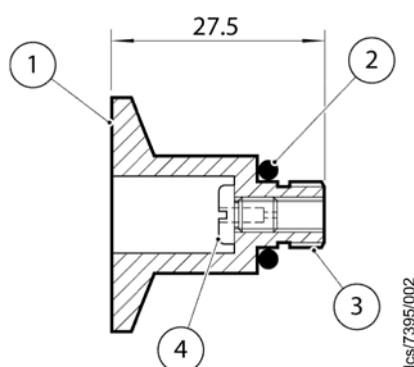

1. NW10 flange
2. O-ring
3. 1/8 inch BSP male thread
4. Removable flow-restrictor

The vent-port adaptor is supplied with a removable flow restrictor and an O-ring to seal the adaptor to the pump. It is suited for all nEXT pump types.

Also available is an extended vent-port adaptor which is intended for use with the split-flow turbo pumps where the backing port is too close to the vent-port to allow the standard vent-port adaptor to be used. The extended vent-port adaptor is supplied with an O-ring to seal to the pump, NW10 centering ring and NW10/16 clamping ring. Refer to Figure 13.

Figure 13 - Extended vent-port adaptor

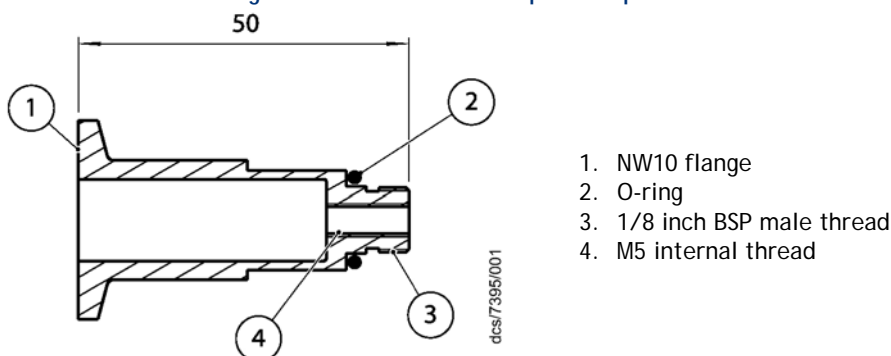

1. NW10 flange
2. O-ring
3. 1/8 inch BSP male thread
4. M5 internal thread

CAUTION

The extended vent-port adaptor is not supplied with a removable flow restrictor. Venting a turbo pump from atmosphere, through the extended vent-port adaptor, would cause damage to the turbo pump. To vent a turbo pump when using the extended vent-port adaptor, you must either control the flow-rate to the adaptor or incorporate a 0.8 mm orifice in the pipeline used to connect to the extended vent-port adaptor.

The extended vent-port adaptor is best suited to the following pump types.

- nEXT240
- nEXT300
- nEXT400

7.2 Technical data

Table 8 - Vent-port adaptor technical data

Internal diameter	0.8 mm
Flange size	NW10
Item number	B580-66-011

Table 9 - Extended vent-port adaptor technical data

Internal diameter	M5 thread
Flange size	NW10
Item Number	B580-66-028

7.3 Installation

7.3.1 Unpack and inspect

Remove all packing materials and protective covers and check the vent-port adaptor.

If the vent-port adaptor is damaged, notify your supplier and the carrier in writing within three days; state the Item Number of the vent-port adaptor together with your order number and your supplier's invoice number. Retain all packing materials for inspection. Do not use the vent-port adaptor if it is damaged.

7.3.2 Connect the vent-port adaptor



WARNING

Before you install the accessory, ensure that you switch off the pump and disconnect the power supply as described below.

1. Switch off the pump, isolate the pump controller from the electrical supply, and wait for the pump to stop rotating.
2. Unscrew and remove the manual vent-valve from the nEXT pump.
3. Refer to [Figure 12](#) and [13](#). Check that the vent-port adaptor has an O-ring (2) fitted and screw the adaptor into the 1/8 inch BSP vent-port. Tighten the adaptor so that it seals firmly against the face of the vent-port.
4. Connect your vent pipeline to the NW10 flange (1) of the adaptor with suitable fittings.

8 VRX vent-restrictor

8.1 Description

Note: A VRX vent-restrictor can be fitted in any nEXT vent port or purge port.

Fit a VRX vent-restrictor to your nEXT pump if you will vent the pump when the pump speed is above 50% of full rotational speed. The vent-restrictor restricts the flow-rate of the vent gas into the nEXT pump.

You can fit the VRX vent-restrictor directly to the inlet of a vent-port adaptor, together with a TAV vent-valve (if required). Note that you must fit the vent-restrictor before you fit the TAV vent-valve or vent-port adaptor.

8.2 Technical data

Table 10 - Vent-restrictor technical data

VRX	Orifice diameter	Item Number
VRX10	0.1 mm	B580-66-021
VRX20	0.2 mm	B580-66-022
VRX30	0.3 mm	B580-66-023
VRX50	0.5 mm	B580-66-024
VRX70	0.7 mm	B580-66-025

8.3 Installation

8.3.1 Unpack and inspect

Remove all packing materials and protective covers and check the vent-restrictor. The VRX identification number (Figure 14, item 5) is located on the restrictor base; for example, if you have a VRX20 vent-restrictor, '20' will be shown on the base of the restrictor.

If the vent-restrictor is damaged, notify your supplier and the carrier in writing within three days; state the Item Number of the vent-restrictor together with your order number and your supplier's invoice number. Retain all packing materials for inspection. Do not use the vent-restrictor if it is damaged.

8.3.2 VRX vent-restrictor selection

Make sure that you have the correct vent-restrictor for your pump and vacuum system. Refer to your nEXT pump instruction manual for selection details.

You must not exceed the maximum allowable rate of pressure rise specified in the nEXT pump instruction manual.

8.3.3 Fit the vent-restrictor



WARNING

Before you install the accessory, ensure that you switch off the pump and disconnect the power supply as described below.

Use the following procedure to fit the vent-restrictor to a nEXT pump:

1. Switch off the pump, isolate the pump controller from the electrical supply, and wait until the pump has stopped rotating.
2. Remove the vent-valve or plug from the nEXT pump, or disconnect the vacuum connections from the purge port as appropriate.
3. Refer to Figure 14. If a vent-restrictor is already fitted, fit a suitable M3 screw into the M3 tapped hole (2) in the restrictor, and then pull the screw to remove the old vent-restrictor.
4. Fit a suitable M3 screw to the new restrictor and push the new restrictor fully into the vent-port or purge port of the nEXT port.
5. Remove the M3 screw and refit the vent-valve or plug, or reconnect the vacuum connections to the purge port.

Figure 14 - VRX vent-restrictor

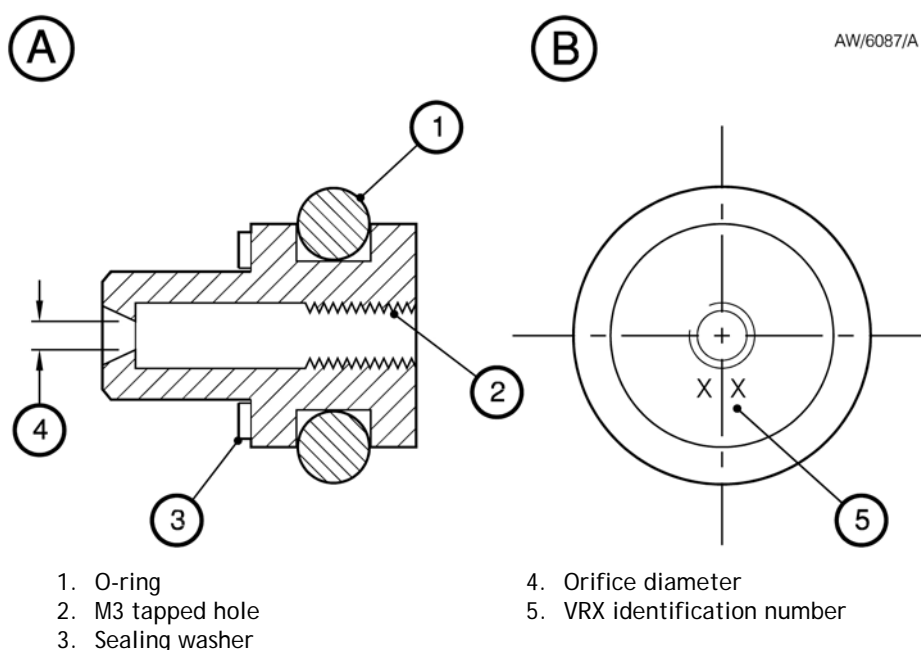

9 WCX water-cooler

9.1 Description

A WCX water-cooler can be fitted to all nEXT pumps, to provide water cooling during pump operation. Refer to the pump instruction manual to determine the operating conditions under which you must use water cooling.

9.2 Technical data

Table 11 - WCX water-cooler technical data

Item number B80000815	To fit pump models All nEXT pumps
Water connection dimensions	Push-fit connectors suitable for 10 mm OD plastic pipe

9.3 Installation

9.3.1 Unpack and inspect

Remove all packing materials and protective covers and check the WCX water-cooler.

If the water-cooler is damaged, notify your supplier and the carrier in writing within three days; state the Item Number of the water-cooler together with your order number and your supplier's invoice number. Retain all packing materials for inspection. Do not use the water-cooler if it is damaged.

9.3.2 Fit the water-cooler to the pump



WARNING

Before you install the accessory, ensure that you switch off the pump and disconnect the power supply as described below.

1. Switch off the pump. Isolate the pump controller from the electrical supply, and wait until the pump has stopped rotating.
2. Refer to [Figure 2 & 15](#). Fit the water-cooler to the pump as described below.

9.3.2.1 WCX water-cooler

1. If necessary, remove the old water -cooler from the pump, and retain the fixing screws.
2. Use the screws removed in step 1, or use the two supplied, to secure the new water-cooler to the pump in position as shown in [Figure 2](#).
3. Push the 10 mm OD plastic tube (not supplied) into the push fit connectors ensuring that they are securely inserted.
4. Briefly turn on the cooling water supply and check for leaks. Seal any leaks found.

9.4 Operation

CAUTION

Ensure that the cooling-water flow is correct for the pump operating conditions. Insufficient or excess cooling-water flow can damage the pump.

Refer to your nEXT pump instruction manual for:

- The operating conditions under which you must use water-cooling.
- The necessary cooling-water supply flow rates and temperatures.

Figure 15 - WCX water-cooling

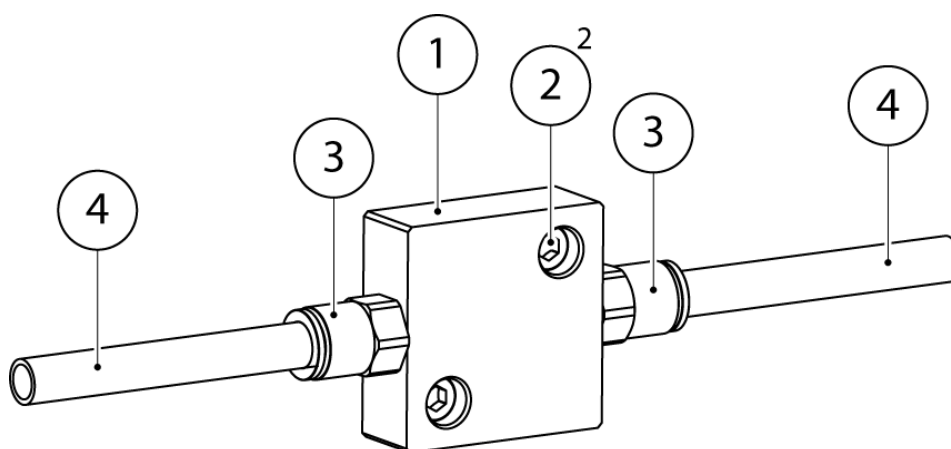

Item number	Product description	Quantity
1	Water-cooling block	1
2	M6 x 16 socket cap screw	2
3	Push fit connector 10 OD pipe 1/4 BSP	2
4	Plastic tube 10 OD	ref only

10 nEXT Interface Cable

10.1 Description

The nEXT interface cable allows you to connect the serial link of an nEXT Pump to a PC. Serial commands can then be used to control and monitor the nEXT Pump.

Refer to the pump instruction manual for information on the serial protocol utilisation, including a full serial command set and details of the required message structure.

10.2 Technical data

Table 12 - nEXT interface cable technical data

Item number B800-00-808	To fit pump models All nEXT pumps
Pump connection	15 way female D-type socket (dual-entry back shell)
Supply connection	15 way male D-type plug (single-entry back shell)
PC connection	9 way female D-type socket (single-entry back shell)

10.3 Installation

10.3.1 Unpack and inspect

Remove all packing materials and check the interface cable.

If the interface cable is damaged, notify your supplier and the carrier in writing within three days; state the Item Number of the interface cable together with your order number and your supplier's invoice number. Retain all packing materials for inspection. Do not use the interface cable if it is damaged.

10.3.2 Fit the interface cable to the pump



WARNING

Before you install the accessory, ensure that you switch off the pump and disconnect the power supply as described below.

1. Switch off the pump. Isolate the pump controller from the electrical supply and wait until the pump has stopped rotating.
2. Disconnect the nEXT pump logic interface cable from the TIC Turbo Instrument Controller or TIC Turbo Controller or from your own systems, depending upon your connection method.
3. Refer to Figure 16 for the interface cable connection diagram.
4. Connect the 15 way female D-type socket (pump connection) of the interface cable to the nEXT pump logic interface cable.
5. Connect the 15 way male D-type plug (supply connection) of the interface cable either to the back of the TIC (refer to the TIC instruction manual for further information) or to the pump connection of your own system, depending upon your connection method.
6. Connect the 9 way female D-type socket (PC connection) of the interface cable either to the serial port of your PC or to a suitable USB to RS232 converter, depending upon your PC serial port availability.

10.4 Operation



WARNING

Ensure that the interface cable is correctly and securely fitted before turning on the power supply and starting the pump, as described in [Section 10.3.2](#).

Refer to your nEXT pump instruction manual for information detailing pump operation and serial protocol utilisation.

Figure 16 - nEXT interface cable

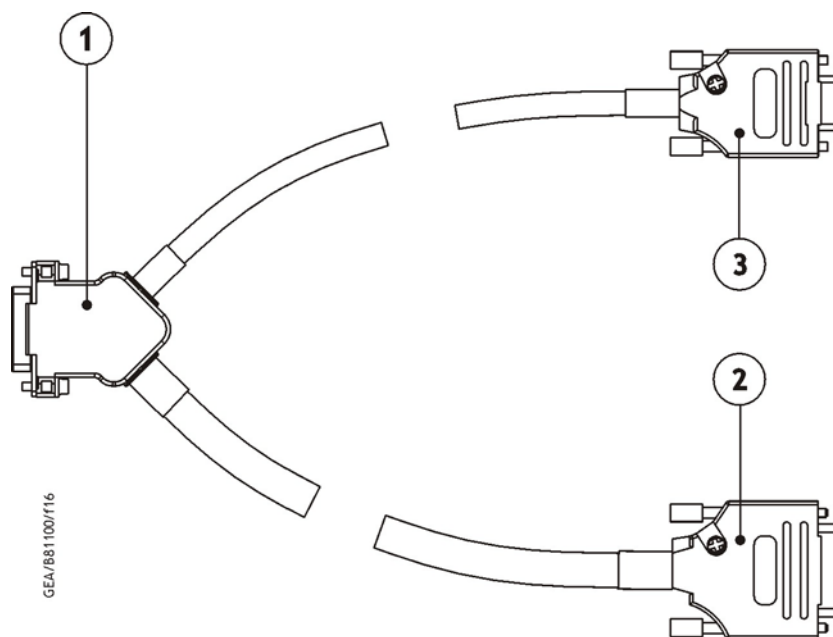

1. Pump connection
2. Supply connection
3. PC connection

11 Maintenance

Edwards nEXT accessories require little user maintenance and contain no user serviceable parts. To maintain the accessories in normal use, do the appropriate checks below when you maintain the pump.

- Check that all mechanical fixings are secure.
- Check that any electrical connections are secure.
- Check that any electrical supply cables are undamaged.

This page has been intentionally left blank.