

# EPS 500 Power supply

INSTRUCTION MANUAL

## Trademark credit

Edwards and the Edwards logo are trademarks of Edwards Limited, Innovation Drive, Burgess Hill, West Sussex RH15 9TW.

## Disclaimer

The content of this manual may change from time to time without notice. We accept no liability for any errors that may appear in this manual nor do we make any expressed or implied warranties regarding the content. As far as practical we have ensured that the products have been designed and constructed to be safe and without risks when properly installed and used in accordance with their operating instructions.

We accept no liability for loss of profit, loss of market or any other indirect or consequential loss whatsoever.

Product warranty and limit of liability are dealt with in our standard terms and conditions of sale or negotiated contract under which this document is supplied.

You must use this product as described in this manual. Read the manual before you install, operate, or maintain the product.

## CE Declaration of Conformity

Edwards Ltd  
Innovation Drive  
Burgess Hill  
West Sussex  
RH15 9TW  
UK

The following product

*B8J200811      EPS500 Power Supply for Turbomolecular Pumps*

Is in conformity with the relevant requirements of European CE legislation:

2014/35/EU	Low voltage directive (LVD)
2014/30/EU	Electromagnetic compatibility (EMC) directive
2011/65/EU	Restriction of certain hazardous substances (RoHS) directive as amended by Delegated Directive (EU) 2015/863

Based on the relevant requirements of harmonised standards:

EN 61010-1:2010	Safety requirements for electrical equipment for measurement, control and laboratory use. General requirements
EN 61326-1:2013	Electrical equipment for measurement, control and laboratory use. EMC requirements. General requirements Class A Emissions, Industrial Immunity

Documentation Officer: Jelena Havelkova, Spielberk Office Centre, Holandska 10, Brno, 63900 Czech Republic,  
☎: +42(0) 734 418 896, ✉: documentation@edwardsvacuum.com

This declaration, based on the requirements of the listed Directives and EN ISO/IEC 17050-1, covers all product serial numbers from this date on: *13<sup>th</sup> February 2020*.



*Ian Keech – VP Engineering  
Scientific Vacuum Division  
Burgess Hill*



*Axel Guddas – General Manager  
Cologne*

# **Additional Legislation and Compliance Information**

## **EU EMC Directive: Class A/B Industrial equipment**

Caution: This equipment is not intended for use in residential environments and may not provide adequate protection to radio reception in such environments.

## **EU REACH Regulation Compliance**

This product is a complex article which is not designed for intentional substance release. To the best of our knowledge the materials used comply with the requirements of REACH. The product manual provides information and instruction to ensure the safe storage, use, maintenance and disposal of the product including any substance based requirements.

## **Article 33.1 Declaration**

This product does not knowingly or intentionally contain Candidate List Substances of Very High Concern above 0.1%ww by article as clarified under the 2015 European Court of Justice ruling in case C-106/14.

# Contents

<b>1. Safety and compliance.</b> . . . . .	<b>4</b>
1.1 Definition of Warnings and Cautions. . . . .	4
1.2 Safety symbols. . . . .	4
<b>2. Important safety information.</b> . . . . .	<b>6</b>
<b>3. Description.</b> . . . . .	<b>7</b>
3.1 Design and function. . . . .	7
3.2 Supplied equipment. . . . .	7
3.3 Technical data. . . . .	7
3.4 Ordering data. . . . .	8
<b>4. Installation.</b> . . . . .	<b>9</b>
4.1 Placement. . . . .	9
4.2 Conforming use. . . . .	9
4.3 Providing the connections. . . . .	9
4.4 Changing the fuses. . . . .	10
<b>5. Maintenance.</b> . . . . .	<b>11</b>
5.1 Return the equipment or components for service . . . . .	11



# 1. Safety and compliance

## 1.1 Definition of Warnings and Cautions

**NOTICE:**

For safe operation from the start, read these instructions carefully before you install or commission the equipment.



Read all the safety instructions in this section and the rest of this manual carefully and make sure that you obey these instructions. The equipment must only be operated and maintained by trained personnel in the proper condition and as described in this instruction manual.

Obey local and state requirements and regulations. If you have any questions about safety, operation or maintenance of the device, please contact our nearest subsidiary.

Important safety information is highlighted as warning and caution instructions. Obey these instructions.



**WARNING:**

If you do not obey a warning, there is a risk of injury or death. Different symbols are used according to the type of hazard.



**CAUTION:**

If you do not obey a caution, there is a risk of minor injury, damage to equipment, related equipment or process.



**NOTICE:**

Information about properties or instructions for an action which, if ignored, will cause damage to the pump or the system.

We reserve the right to change the design and the stated data. The illustrations are not binding.

Keep the instructions for future use.

## 1.2 Safety symbols

	<p>Warning - Dangerous Voltage Indicates hazards arising from dangerous voltages.</p>
	<p>Warning - Hot Surfaces Indicates that the marked item may be hot and should not be touched without taking precautions.</p>



**Warning - Dangerous Substances**

Indicates hazards arising from operating the device in a chemically aggressive environment.

## 2. Important safety information



### **WARNING: ELECTRIC SHOCK**

Failure to obey the information that follows this Warning could result in injury or death by electric shock. Read and obey this safety information.

- The electrical installation must be done by a sufficiently qualified person. Obey the national regulations in the country of use (for example, EN 50110-1 for Europe).
- Lethal voltages are present at the mains connections. Before you start maintenance and service work, de-energise (lockout/tagout) the product first.
- Unplug any connectors only when the mains voltage is switched off and the pump does no longer turn.
- At speeds below 200 Hz, there is not enough power for the LEDs. The pump can continue to operate without LED indication.
- Unauthorized device conversion and modifications are prohibited for safety reasons.
- Hazardous voltages are present within the converter. Contact with the converter can cause death or injury. After the pump has stopped, disconnect the converter from the mains power. Make sure that the pump cannot be accidentally switched on (lockout/tagout) before you open it. There are no user serviceable parts in the converter.
- Put connecting lines so that they cannot be damaged. Protect the lines against humidity and contact with water. Prevent any heat stress on the line due to unfavourable conditions.
- Support the connecting lines so that the pumps are not exposed to major mechanical stress.
- Do not expose the converter and the connections to dripping water. Read the information on the IP type of protection.
- When converter and connecting lines are stored in a humid atmosphere, they can suffer corrosion. Corrosion can cause conductive deposits which can cause short-circuits and reduce the insulation levels of electrical components
- Transport the converter and connecting cables in their original packaging to avoid mechanical damage. This can prevent air gaps and creepage distances.
- Do not make electrical connections until the pump and accessories (e.g. air cooler) have been installed mechanically.



### 3. Description

Figure 1 EPS 500, front side



#### 3.1 Design and function

The power supply EPS 500 converts the mains voltage into a DC voltage for the turbomolecular pumps nEXT 730D and 930D.

#### 3.2 Supplied equipment

- Power supply
- 4 rubber feet

#### 3.3 Technical data

Supply voltage (POWER IN)	100 - 240 V AC $\pm$ 10 %
Frequency	50/60 Hz
Power consumption maximum at ultimate pressure operation of the pump	650 VA 450 VA
DC power supply voltage (POWER OUT)	48 V DC
Maximum DC current consumption	10 A
Max. length of the DC cable at 3 x 1.5 mm <sup>2</sup> at 3 x 2.5 mm <sup>2</sup>	5 m 20 m
Ambient temperature during operation storage	10 - 40 °C -10 - 70 °C
Relative air humidity; non condensing	5 to 85 %

Type of protection	IP 30
Overvoltage category	II
Contamination grade	2
Weight, approx.	4 kg

Figure 2 Dimensions in mm

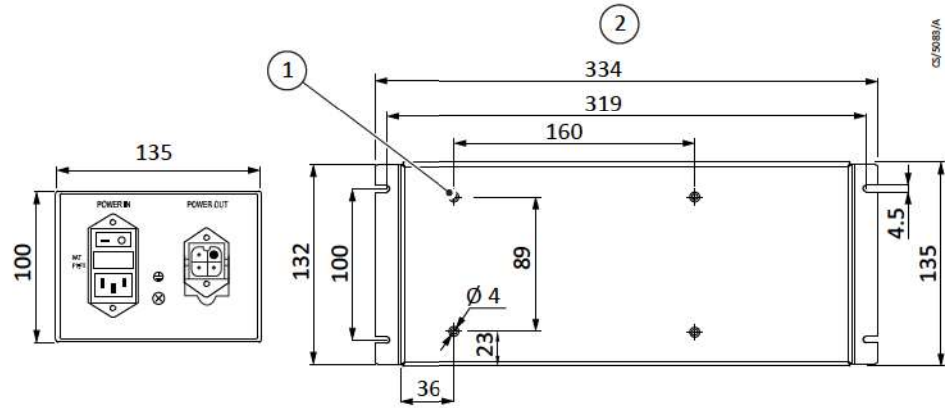

1. Countersink for M4 (4x)

2. Top view

### 3.4 Ordering data

		Part No.
EPS 500		B8J200811
DC cable (connection between EPS 500 and nEXT 730/930D)	1 m	B8J200821
	3 m	B8J200822
	5 m	B8J200823

## 4. Installation

### 4.1 Placement

Put the EPS 500 on a flat, smooth surface or attach it with screws. If the EPS 500 is not attached with screws, install the supplied rubber feet.



#### CAUTION

Do not block the heat dissipation of the EPS 500. Make sure there is sufficient ventilation. The ambient temperature during operation must not exceed 40 °C (104 °F).



#### WARNING

If the EPS 500 is built into a device, install a safety switch cut-off between the EPS 500 and the mains.



#### CAUTION

Do not operate the EPS 500 with the tested mains cable in a chemically aggressive environment. If you operate the EPS 500 in a chemically aggressive environment replace the mains cable with a resistant one.

Figure 3 Air flow pattern; top view

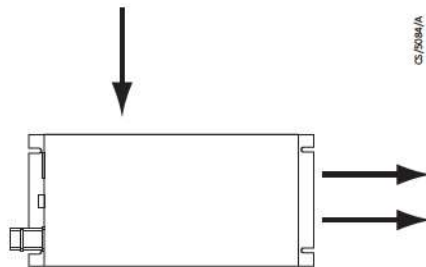

### 4.2 Conforming use

The EPS 500 is used to operate the turbomolecular pumps. Other devices must not be connected.

### 4.3 Providing the connections

Attach the connection line to the pump; see Fig. 4.

We recommend that you use the cables listed in Section 3.4. If you decide use other cables, use a shielded cable and obey the information given in Fig. 5.



**WARNING**

Use the ground bolt to connect the device to the protective ground system.

Connect the mains cable.

Figure 4 Example of a connection schematic

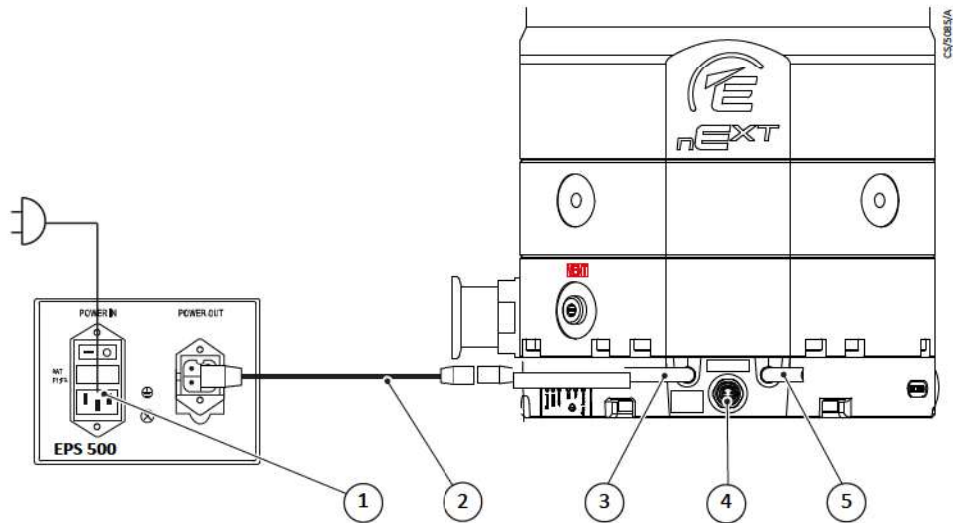

- 1. Mains connection (100 - 240 V)
- 2. DC cable
- 3. 48 V DC pump power supply
- 4. Accessory connector
- 5. Control interface

Figure 5 POWER OUT plug

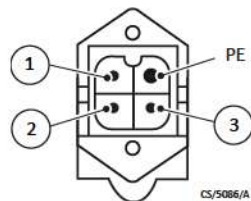

- 1. + 48 V DC
- 2. 0 V
- 3. not connected

## 4.4 Changing the fuses

The device has mains fuses 8 A slow blow.

To change fuses, disconnect the mains cable and then remove the protective cap below the on/off switch.



## 5. Maintenance

Dust and moisture can cause contamination in the power supply. This contamination can cause the power supply to overheat or short-circuit. We recommend that the power supply is cleaned every 5 years.

### 5.1 Return the equipment or components for service

Before you send your equipment to us for service or for any other reason, you must send us a completed Declaration of Contamination of Vacuum Equipment and Components – Form HS2. The HS2 form tells us if any substances found in the equipment are hazardous, which is important for the safety of our employees and all other people involved in the service of your equipment. The hazard information also lets us select the correct procedures to service your equipment.

We provide instructions for completing the form in the Declaration of Contamination of Vacuum equipment and Components – Procedure HS1.

If you are returning a vacuum pump, note the following:

- If a pump is configured to suit the application, make a record of the configuration before returning the pump. All replacement pumps will be supplied with default factory settings.
- Do not return a pump with accessories fitted. Remove all accessories and retain them for future use.
- The instruction in the returns procedure to drain all fluids does not apply to the lubricant in pump oil reservoirs.

Download the latest documents from [www.edwardsvacuum.com/HSForms/](http://www.edwardsvacuum.com/HSForms/), follow the procedure in HS1, fill in the electronic HS2 form, print it, sign it, and return the signed copy to us.



**NOTICE:**

**If we do not receive a completed HS2 form, your equipment cannot be serviced.**

This page has been intentionally left blank.

This page has been intentionally left blank.

Chemtech Scientific provides access to this content as a courtesy.  
We do not own the content contained in this document.  
All rights and credit go directly to its rightful owners.  
[www.chemtechsci.com](http://www.chemtechsci.com)  
Call us at: 484-424-9415

