



# EPS 800 Power supply

## INSTRUCTION MANUAL

## Copyright notice

©Edwards Limited 2021. All rights reserved.

## Trademark credit

Edwards and the Edwards logo are trademarks of Edwards Limited, Innovation Drive, Burgess Hill, West Sussex RH15 9TW.

## Disclaimer

The content of this manual may change from time to time without notice. We accept no liability for any errors that may appear in this manual nor do we make any expressed or implied warranties regarding the content. As far as practical we have ensured that the products have been designed and constructed to be safe and without risks when properly installed and used in accordance with their operating instructions.

We accept no liability for loss of profit, loss of market or any other indirect or consequential loss whatsoever.

Product warranty and limit of liability are dealt with in our standard terms and conditions of sale or negotiated contract under which this document is supplied.

You must use this product as described in this manual. Read the manual before you install, operate, or maintain the product.

# Contents

<b>1. Important safety information.</b> .....	<b>4</b>
<b>2. Description.</b> .....	<b>5</b>
2.1 Supplied equipment. ....	5
2.2 Ordering information. ....	5
2.3 Accessories. ....	5
2.4 Technical data. ....	5
<b>3. Installation.</b> .....	<b>7</b>
3.1 Use as a benchtop unit. ....	7
3.2 Installation to the pump. ....	7
<b>4. Operation.</b> .....	<b>10</b>
4.1 Start up. ....	10
4.2 Shut down. ....	10
4.3 Maintenance. ....	10
<b>5. Certificates.</b> .....	<b>11</b>

# 1. Important safety information



## CAUTION: SAFETY INFORMATION

Refer to the individual pump operating instructions for applicable safety information.



## CAUTION: DANGEROUS VOLTAGE

Risk of electric shock and damage to the equipment. Make sure that the mains power supply is switched off before you connect or disconnect the mains cable.

The EPS 800 must only be opened by certified Edwards Service Centres. Opening by unauthorised personnel voids warranty.

Figure 1 Do not open

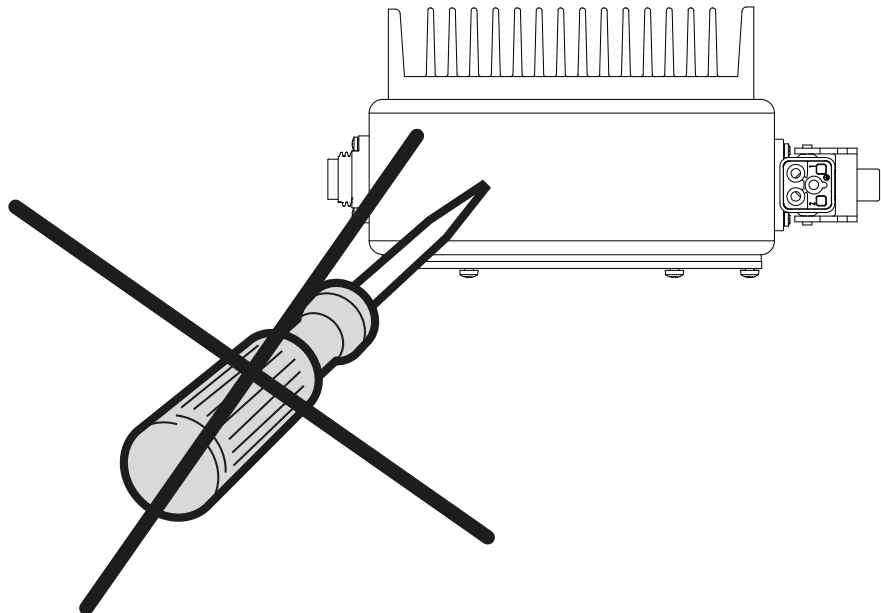

## 2. Description

The EPS 800 is a power supply unit for powering the nEXT 730D/930D/1230D turbomolecular pumps. It is for indoor use only.

The mains input is protected by a fuse.

The EPS 800 can be fitted to the pump or used as a benchtop unit.

### 2.1 Supplied equipment

- EPS 800
- 4 feet (to be assembled for use as a benchtop unit)

### 2.2 Ordering information

EPS 800	B8J200819
---------	-----------

### 2.3 Accessories

Cable nEXT 730D/930D/1230D - EPS 800	
3 m	B8J200824
5 m	B8J200825
Mains cable for EPS 800, 2.5 m long	
with Euro plug	B8J200829
with US plug 5-15 P	B8J200830
with UK plug	B8J200831
Mains input socket (only)	B8J200833
Bracket for mounting to the pump (washers and bolts enclosed)	B8J200832

### 2.4 Technical data

<b>Input</b>	
Mains voltage	100 - 240 V a.c. $\pm$ 10%, 50/60 Hz
Maximum power consumption	1100 VA
Efficiency	84 %
Leakage current	2 mA / 230 V a.c.
AC fusing	15 A slow-blow
<b>Output</b>	
Nominal DC output voltage	48 V $\pm$ 5% /-10%
Maximum DC continuous current	10.65 A
DC peak current (30 min) (limited by pump, controlled by power supply)	17.1 A
Maximum rated power output	800 W
<b>Other data</b>	

Weight	4.9 kg
Protection type EN 60529 UL50 E	IP 54 Type 1
Ambient temperature during operation in storage	5 – 40 °C -15 – +70 °C
Relative air humidity	5 to 85 % non condensing
Overvoltage category	II
Contamination grade	2
Resistance to interference	61000-6-2 Industry
Interference sourcing	61000-6-3 Household
Maximum operating altitude	2000 m above sea level without any power derating >2000 m up to 3000 m with a derating of 1%/100 m

Figure 2 Dimensions in mm

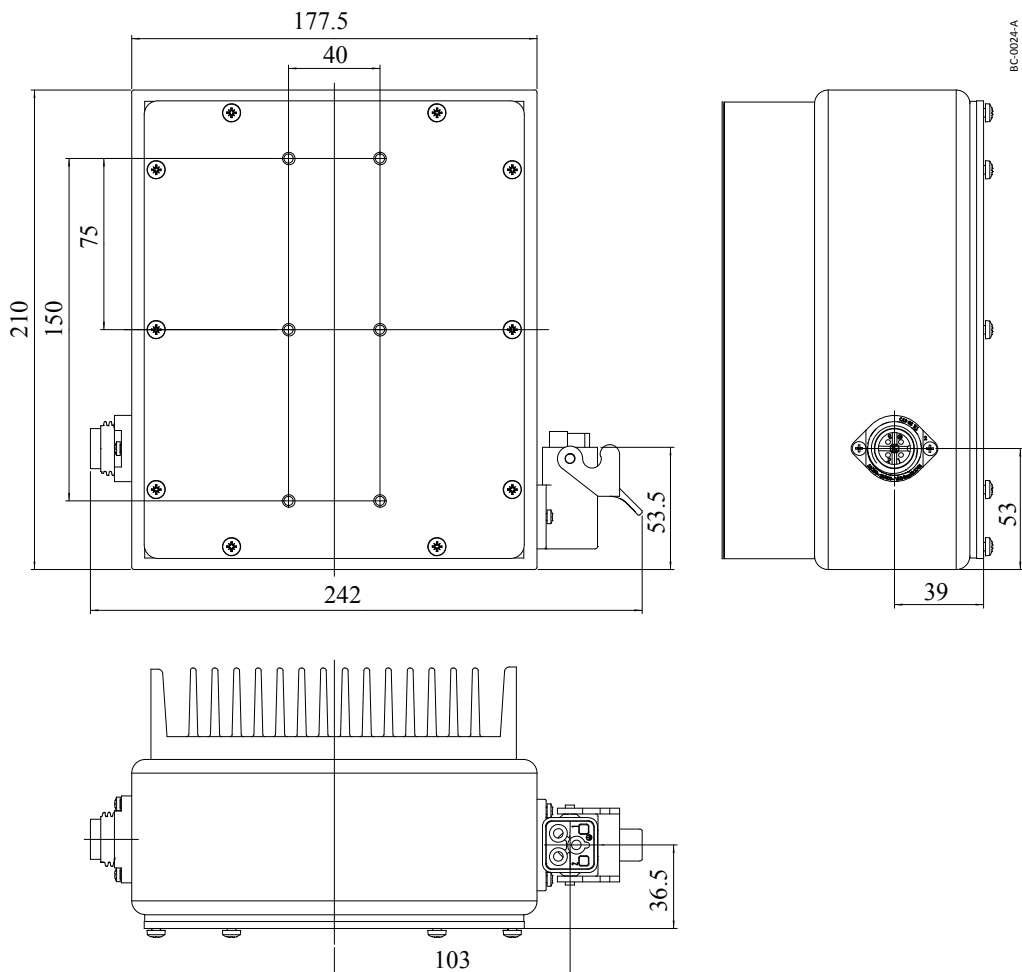

### 3. Installation

Refer to the individual pump operating instructions for installation information.

#### 3.1 Use as a benchtop unit

**Figure 3** Benchtop unit

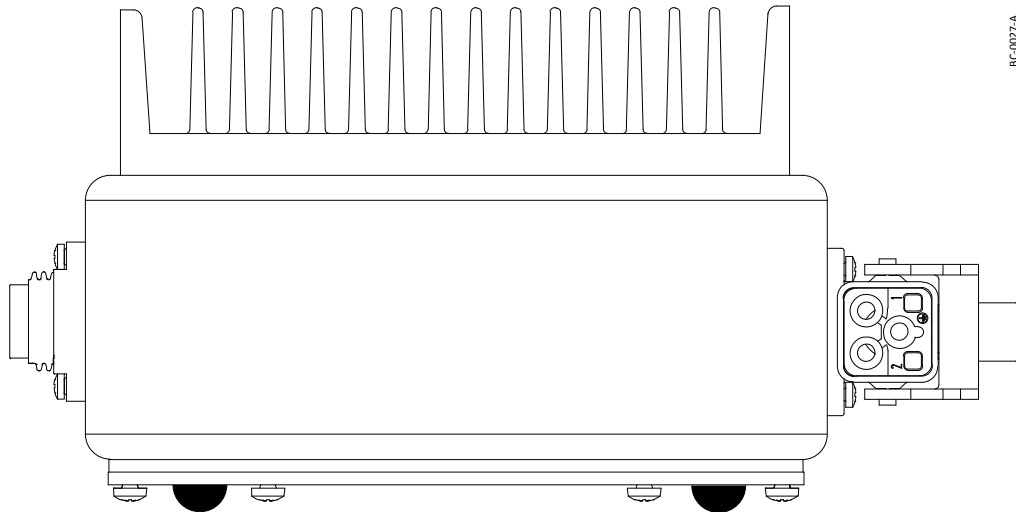

Fix the supplied adhesive feet to the power supply unit and place the unit on an even, level surface.

#### 3.2 Installation to the pump

1. Attach the bracket to the power supply unit using 6x M4x14 bolts, washers and spring washers. Tighten with a torque of 3 Nm. Refer to [Figure: Mount the bracket to the power supply](#).
2. Attach the bracket with the power supply unit to the pump. Refer to [Figure: Mount the bracket to the pump](#).
  - If there is no air cooler, attach the bracket using 4x M5x14 bolts, washers and spring washers and tighten with a torque of 5 Nm.
  - If the air cooler is mounted, attach the bracket using 4x M5x16 bolts, washers and spring washers and tighten with a torque of 5 Nm.
3. Insert the connecting cable between the pump and EPS 800.
4. Tighten the cable through the plug at the connection end.

The unit is not equipped with a mains switch. It will power up after the mains cable is connected.

**Figure 4** Mount the bracket to the power supply

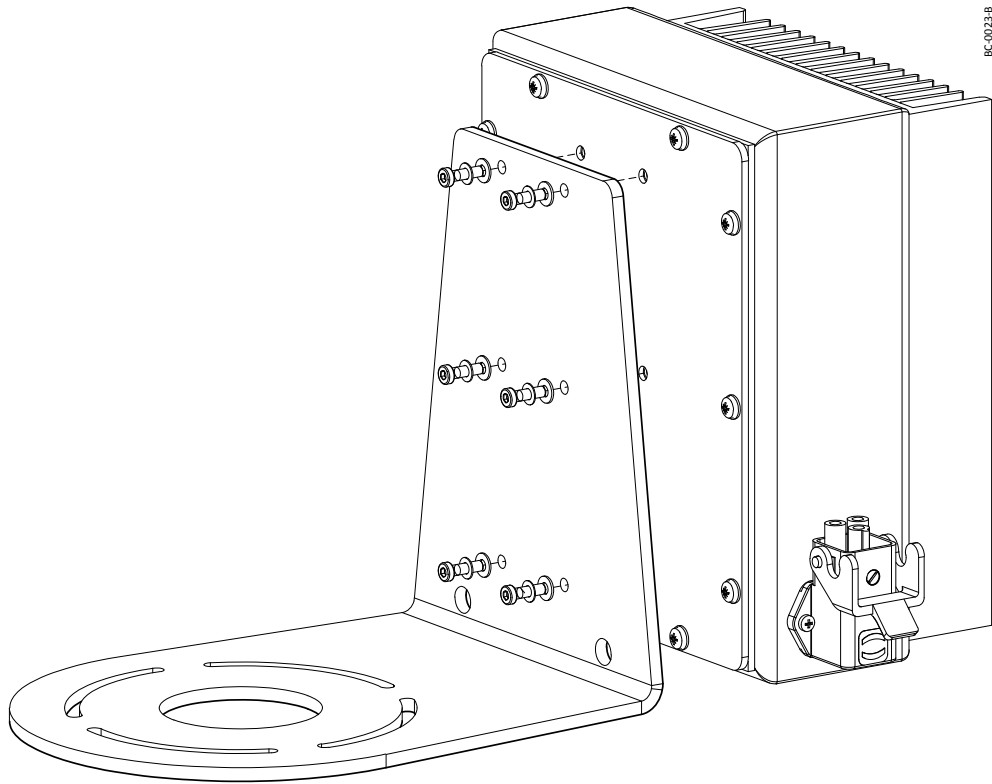



**Figure 5** Mount the bracket to the pump

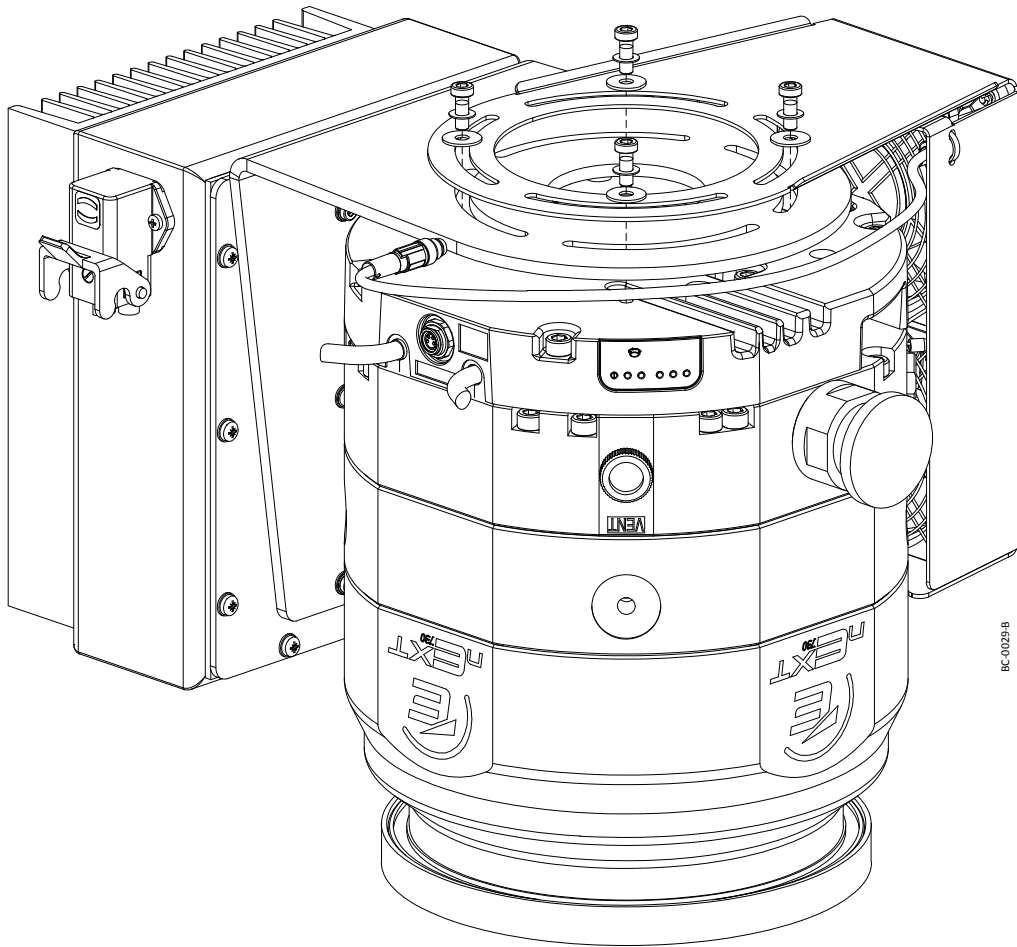

## 4. Operation

### CAUTION: DANGEROUS VOLTAGE



Risk of electric shock and damage to the equipment. The turbomolecular pump and the EPS 800 must only be operated if installed in compliance with the information provided in the Operating Instructions.

The disconnecting device must be easily accessible.

### 4.1 Start up

#### CAUTION: DANGEROUS VOLTAGE



Risk of electric shock and damage to the equipment. Make sure that the mains power supply is switched off before you connect or disconnect the mains cable.

The mains power supply must have a suitable earth connection.

To start the EPS 800 do the steps that follow:

1. Plug in the mains cable.
2. Secure the mains cable so that it cannot be pulled out inadvertently.

To test the connection, switch the turbomolecular pump on and off. Refer to the applicable turbomolecular pump operating instructions for information.

The turbomolecular pump will start only when the mains cable is plugged and a start command is provided.

### 4.2 Shut down

To shut down the EPS 800 do the steps that follow:

1. Switch off the turbomolecular pump.
2. Wait for the rotor of the pump to stop. The Green status LED will stop flashing to confirm that the rotor is ideal.

#### Note:

*The rotor can take several minutes to stop. With the DC power supply off, the turbomolecular pump will act as a generator supplying the frequency converter with energy as indicated by the yellow power LED.*

3. Disconnect the mains plug from the power supply.

In case of an emergency shutdown, disconnect the mains plug.

### 4.3 Maintenance

The EPS 800 is maintenance free. Repairs must only be done by Edwards.

You must disconnect the mains plug from power supply and make sure that the system is protected against automatic restart during any repair work.

## 5. Certificates

The EPS 800 have been successfully tested by the TÜV Rheinland of North America according to the requirements of

- UL 61010-1:2012  
CSA C22.2 No. 61010-1-12

cTUVus Certificate No. CU 72204401.01

cTUVus File No. 32084633.001

The TÜV Rheinland of North America is a “Nationally Recognised Testing Laboratory” (*NRTL*) for the USA and Canada.

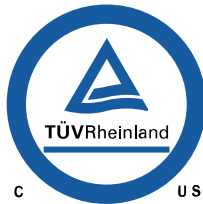



## EU Declaration of Conformity

Edwards Ltd  
Innovation Drive  
Burgess Hill  
West Sussex  
RH15 9TW  
UK

Declare that the following product

EPS 800 Power supply for Turbomolecular Pumps  
B8J200819

Is in conformity with the relevant requirements of European CE legislation:

- |            |   |
|------------|---|
| 2014/35/EU | Low voltage directive (LVD)   |
| 2014/30/EU | Electromagnetic compatibility (EMC) directive<br>Class B Emissions, Industrial Immunity                         |
| 2011/65/EU | Restriction of certain hazardous substances (RoHS) directive<br>as amended by Delegated Directive (EU) 2015/863 |

Based on the relevant requirements of harmonised standards:

- |                         |  |
|-------------------------|--|
| EN 61010-1:2010/A1:2019 | Safety requirements for electrical equipment for measurement, control and laboratory use. General requirements |
| EN 61326-1:2013         | Electrical equipment for measurement, control and laboratory use. EMC requirements. General requirements       |

This declaration, based on the requirements of the listed Directives and EN ISO/IEC 17050-1, covers all product serial numbers from this date on: 23. February 2021

This declaration becomes invalid if modifications are made to the product.

*Dr. Thomas Dreifert – Engineering Manager  
Product Company Cologne*

*Axel Guddas – General Manager  
Product Company Cologne*

This page has been intentionally left blank.

This page has been intentionally left blank.

This page has been intentionally left blank.

Chemtech Scientific provides access to this content as a courtesy.  
We do not own the content contained in this document.  
All rights and credit go directly to its rightful owners.  
[www.chemtechsci.com](http://www.chemtechsci.com)  
Call us at: 484-424-9415

