

Instruction Manual

EXT Pump Accessories



Chemtech Scientific provides access to this content as a courtesy.
We do not own the content contained in this document.
All rights and credit go directly to its rightful owners.
www.chemtechsci.com
Call us at: 484-424-9415



Contents

| Section | Page |
|----------|---|
| 1 | Introduction 1 |
| 1.1 | Scope and definitions 1 |
| 1.2 | Installation and operation safety 2 |
| 2 | BX bakeout band 7 |
| 2.1 | Description 7 |
| 2.2 | Technical data 7 |
| 2.3 | Installation 8 |
| 2.3.1 | Unpack and inspect 8 |
| 2.3.2 | Fit the BX bakeout band to the pump 8 |
| 2.3.3 | Electrical connection to an EXC controller 8 |
| 2.3.4 | Electrical connection to a TIC relay box 8 |
| 2.3.5 | Electrical connection to an independent electrical supply 8 |
| 2.4 | Operation 9 |
| 3 | ACX air-cooler 11 |
| 3.1 | Description 11 |
| 3.2 | Technical data 11 |
| 3.3 | Installation 28 |
| 3.3.1 | Unpack and inspect 28 |
| 3.3.2 | Side (or radial) mounting 28 |
| 3.3.3 | Axial mounting 29 |
| 3.3.4 | Combined radial and axial mounting 29 |
| 3.3.5 | Electrical connection 30 |
| 3.4 | Operation 30 |
| 4 | TAV vent-valve 33 |
| 4.1 | Description 33 |
| 4.2 | Technical data 33 |
| 4.3 | Installation 34 |
| 4.3.1 | Unpack and inspect 34 |
| 4.3.2 | Fit the TAV vent-valve to the pump 35 |
| 4.3.3 | Electrical connection 35 |
| 4.4 | Operation 35 |
| 5 | Vibration isolator 37 |
| 5.1 | Description 37 |
| 5.2 | Technical data 37 |
| 5.3 | Installation 38 |
| 5.3.1 | Unpack and inspect 38 |
| 5.3.2 | Fit the vibration isolator 38 |
| 6 | Inlet screens 41 |
| 6.1 | Description 41 |
| 6.2 | Technical data 41 |
| 6.3 | Installation 41 |
| 6.3.1 | Unpack and inspect 41 |
| 6.3.2 | Fit or remove the inlet-screen 42 |
| 7 | PRX10 purge-restrictor 45 |

| | | |
|-----------|--|-----------|
| 7.1 | Description | 45 |
| 7.2 | Technical data | 45 |
| 7.3 | Installation | 45 |
| 7.3.1 | Unpack and inspect | 45 |
| 7.3.2 | Fit the purge-restrictor | 46 |
| 7.4 | Operation | 46 |
| 7.4.1 | General | 46 |
| 7.4.2 | Calibration of the PRX10 for different purge gases | 46 |
| 8 | Pump-to-controller cable | 49 |
| 8.1 | Description | 49 |
| 8.2 | Technical data | 49 |
| 8.3 | Installation | 49 |
| 8.3.1 | Unpack and inspect | 49 |
| 8.3.2 | Connect the pump-to-controller cable | 49 |
| 9 | Vent-port adaptor | 51 |
| 9.1 | Description | 51 |
| 9.2 | Technical data | 53 |
| 9.3 | Installation | 53 |
| 9.3.1 | Unpack and inspect | 53 |
| 9.3.2 | Connect the vent-port adaptor | 53 |
| 10 | VRX vent - restrictor | 55 |
| 10.1 | Description | 55 |
| 10.2 | Technical data | 55 |
| 10.3 | Installation | 55 |
| 10.3.1 | Unpack and inspect | 55 |
| 10.3.2 | VRX vent-restrictor selection | 55 |
| 10.3.3 | Fit the vent-restrictor | 56 |
| 11 | WCX water-cooler | 57 |
| 11.1 | Description | 57 |
| 11.2 | Technical data | 57 |
| 11.3 | Installation | 57 |
| 11.3.1 | Unpack and inspect | 57 |
| 11.3.2 | Fit the water-cooler to the pump | 60 |
| 11.4 | Operation | 60 |
| 12 | Maintenance | 61 |
| 13 | Storage and disposal | 63 |
| 13.1 | Storage | 63 |
| 13.2 | Disposal | 63 |

For return of equipment, complete the HS Forms at the end of this manual.

Illustrations

| Figure | | Page |
|--------|--|------|
| 1 | Accessories for EXT DX pumps (EXT75iDX pump shown) | 3 |
| 2 | Accessories for other EXT pumps (EXT250M pump shown) | 4 |
| 3 | Accessories for EXT406PX pumps | 5 |

| | | |
|----|---|----|
| 4 | Accessories for EXTPX split flow pumps | 6 |
| 5 | ACX75 air-cooler dimensions (mm) | 12 |
| 6 | ACX75 air-cooler installation (shown fitted to EXT75DX pump) | 13 |
| 7 | ACX250 air-cooler dimensions (mm) | 14 |
| 8 | ACX250 air-cooler installation (shown fitted to EXT250M pump) | 15 |
| 9 | ACX250 air-cooler axial installation (shown fitted to EXT250M pump) | 16 |
| 10 | ACX250H air-cooler dimensions (mm) | 17 |
| 11 | ACX250H air-cooler installation (shown fitted to EXT255Hi pump) | 18 |
| 12 | ACX400 radial air-cooler dimensions (mm) | 19 |
| 13 | ACX400 radial air-cooler installation | 20 |
| 14 | ACX400 axial air-cooler dimensions (mm) | 21 |
| 15 | ACX400 axial air-cooler installation | 22 |
| 16 | ACX400 axial and radial air-cooler combination installation | 23 |
| 17 | ACX500 air-cooler dimensions (mm) | 24 |
| 18 | ACX500 air-cooler installation (shown fitted to EXT501 pump) | 25 |
| 19 | ACX555 air-cooler dimensions (mm) | 26 |
| 20 | ACX555 air-cooler installation (shown fitted to EXT555H pump) | 27 |
| 21 | EXT DX podule connector plug | 31 |
| 22 | TAV vent-valve dimensions (mm) | 34 |
| 23 | TAV vent-valve connections | 36 |
| 24 | Vibration isolator installation | 39 |
| 25 | ISX inlet-screen | 43 |
| 26 | ISDX inlet-screen | 43 |
| 27 | ISHX inlet-screen | 44 |
| 28 | PRX10 purge-restrictor | 47 |
| 29 | Vent-port adaptor | 51 |
| 30 | Extended vent-port adaptor | 52 |
| 31 | VRX vent-restrictor | 56 |
| 32 | WCX555 water-cooler dimensions (mm) | 58 |
| 33 | WCX555 water-cooler installation | 59 |

Tables

| Table | Page | |
|-------|---|----|
| 1 | BX bakeout band technical data | 7 |
| 2 | ACX air-cooler technical data | 11 |
| 3 | TAV vent-valve technical data | 33 |
| 4 | Vibration isolators technical data | 37 |
| 5 | Inlet-screens technical data | 41 |
| 6 | PRX10 purge-restrictor technical data | 45 |
| 7 | Nitrogen flow rate through the PRX10 purge-restrictor | 47 |
| 8 | Pump-to-controller cables technical data | 49 |
| 9 | Vent-port adaptor technical data | 53 |
| 10 | Extended vent-port adaptor technical data | 53 |
| 11 | Vent-restrictor technical data | 55 |
| 12 | WCX water-cooler technical data | 57 |

1 Introduction

1.1 Scope and definitions

This manual provides installation, operation and maintenance instructions for the Edwards range of accessories for the following EXT pumps:

- EXT70 and EXT70H turbomolecular pumps.
- EXT75DX and EXT75iDX compound molecular pumps.
- EXT250 and EXT250M turbomolecular pumps.
- EXT250H and EXT250Hi compound molecular pumps.
- EXT255H and EXT255Hi compound molecular pumps.
- EXT255DX and EXT255iDX compound molecular pumps.
- EXT351 and EXT501 turbomolecular pumps.
- EXT555H, EXT555HF, EXT555Hi, EXT555H_E and EXT556 compound molecular pumps.
- EXT406PX and EXTPX split flow compound turbomolecular pumps.

The accessories are shown in [Figure 1](#) and [2](#). The Item Numbers for the accessories are listed in the appropriate sections. You must use the accessories as specified in this manual. Read this manual before you install accessories onto your EXT pump.

Important safety information is highlighted as WARNING and CAUTION instructions; you must obey these instructions. The use of WARNINGS and CAUTIONS is defined below.



WARNING

Warnings are given where failure to observe the instruction could result in injury or death to people.

CAUTION

Cautions are given where failure to observe the instruction could result in damage to the equipment, associated equipment and process.

Throughout this manual, page, figure and table numbers are sequential.

The units used throughout this manual conform to the SI international system of units of measurement. When flow rates are specified, the abbreviation 'sccm' is used to mean 'standard cm³ min⁻¹': this is a flow of 1 cm³ min⁻¹ at an ambient temperature of 0 °C and a pressure of 1013 mbar (1.013 x 10⁵ Pa).

In accordance with the recommendations of EN61010, the following warning labels may appear on the pump or its accessories:



Warning - refer to accompanying documentation.



Warning - risk of electric shock.



Warning - hot surfaces.

1.2 Installation and operation safety



WARNING

You must use the procedures described in this manual to install your accessory, and you must obey all safety instructions and take note of all appropriate precautions. If you do not, you can damage the accessory or other equipment and can cause injury to people.



WARNING

The user of the EXT pump system is responsible for safe operation and monitoring of the system.



WARNING

Before you install the accessory, ensure that you switch off the pump and isolate the controller/podule as described below.

Before you install your accessory, you must:

- Switch off the EXT pump and wait until the pump has stopped rotating.
- Isolate the pump controller* from the electrical supply.

If you have an EXT DX pump: isolate the podule from the electrical supply.

* An EXC Controller or a TIC (Turbo Instrument Controller)

Figure 1 - Accessories for EXT DX pumps (EXT75iDX pump shown)

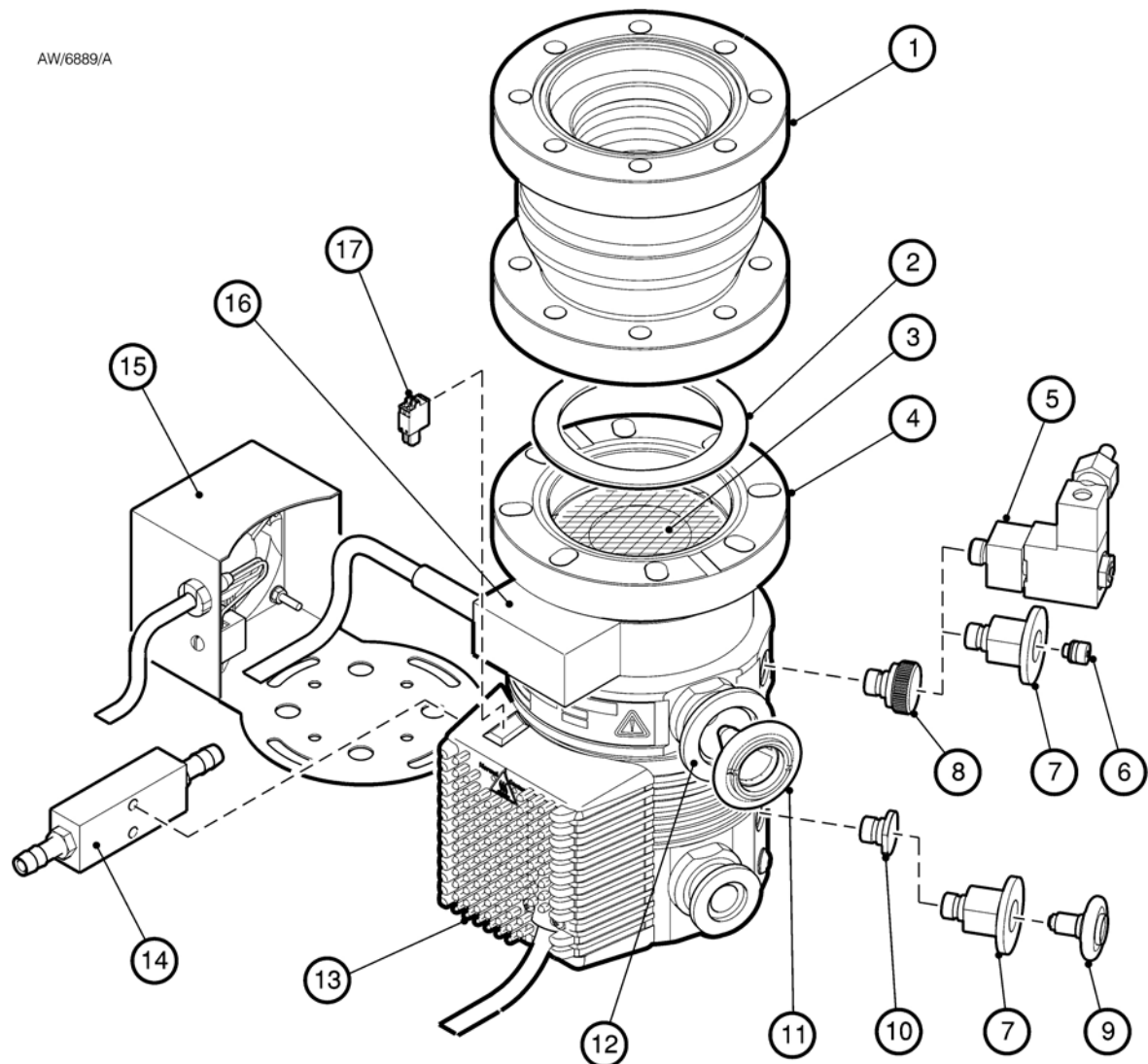

- | | |
|------------------------|--|
| 1. Vibration isolator | 9. Purge-restrictor |
| 2. Inlet-flange seal* | 10. Vent-port plug* |
| 3. Inlet-screen* | 11. Interstage inlet strainer† |
| 4. EXT DX pump | 12. Interstage inlet port† |
| 5. Solenoid vent-valve | 13. Podule |
| 6. Vent-restrictor | 14. Water-cooler |
| 7. Vent-port adaptor | 15. Air-cooler (design varies with pump) |
| 8. Manual vent-valve* | 16. BX bakeout band |
| | 17. Podule connector plug (as required)* |

* Supplied with/fitted to the pump: refer to the instruction manual supplied with your EXT pump.

† Supplied with/fitted to 'i' model pumps only: refer to the instruction manual supplied with your EXT pump.

Figure 2 - Accessories for other EXT pumps (EXT250M pump shown)

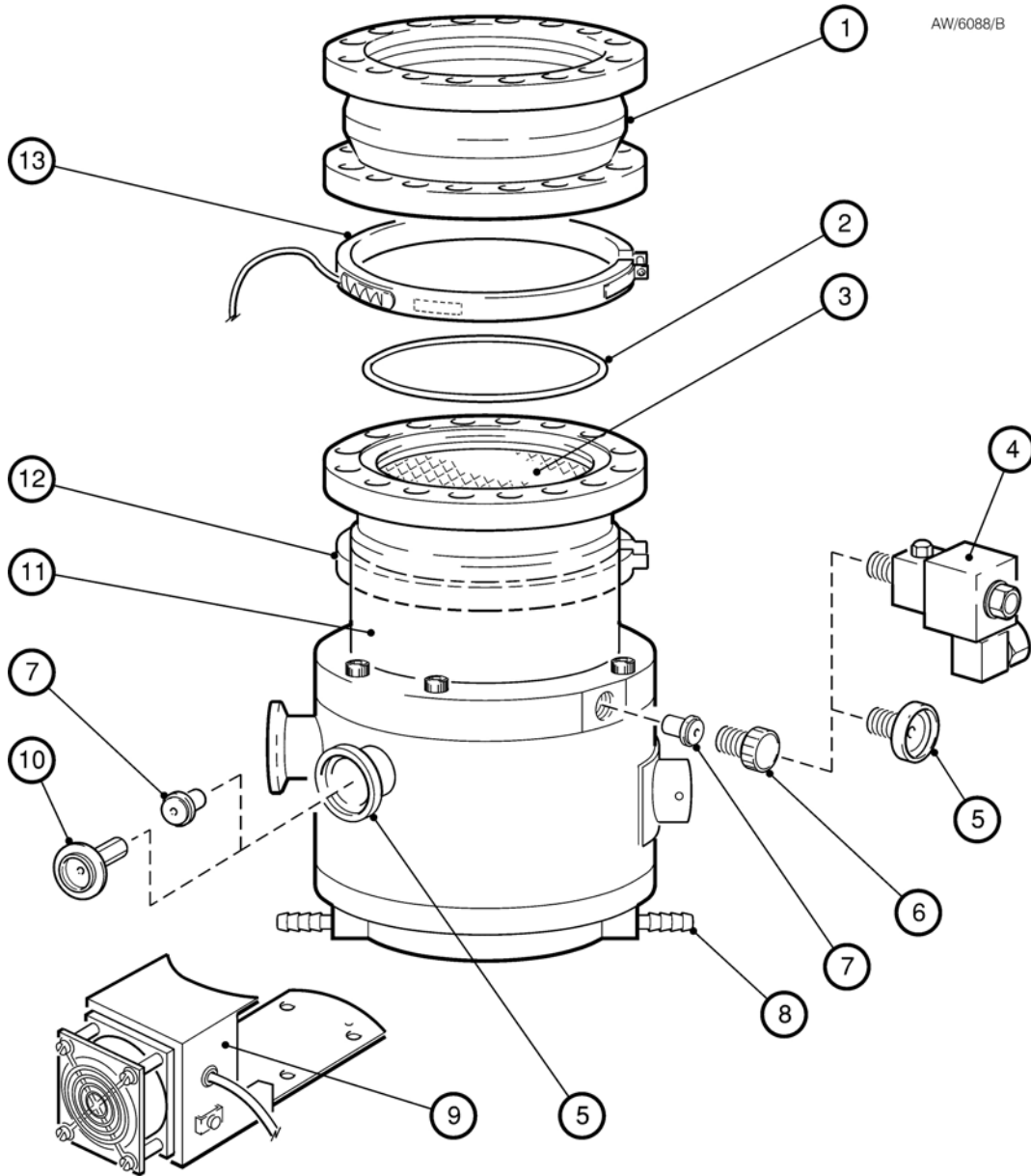

AW/6088/B

- | | |
|---|--|
| <ul style="list-style-type: none"> 1. Vibration isolator 2. Inlet-flange seal* 3. Inlet-screen* 4. Solenoid vent-valve 5. Vent-port adaptor* 6. Manual vent-valve* 7. Vent-restrictor† 8. Water-cooler‡ | <ul style="list-style-type: none"> 9. Air-cooler (design varies with pump) 10. Purge-restrictor (C-model pumps only)* 11. EXT pump 12. Bakeout band position 13. Bakeout band (design varies with pump) |
|---|--|

* Supplied with/fitted to the pump: refer to the instruction manual supplied with your EXT pump.

† VRX10 vent-restrictor: supplied fitted to the vent-port and purge-port of EXT250M pumps only.

‡ Supplied fitted to all pumps, except for EXT555H pumps: refer to the instruction manual supplied with your EXT pump

Figure 3 - Accessories for EXT406PX pumps

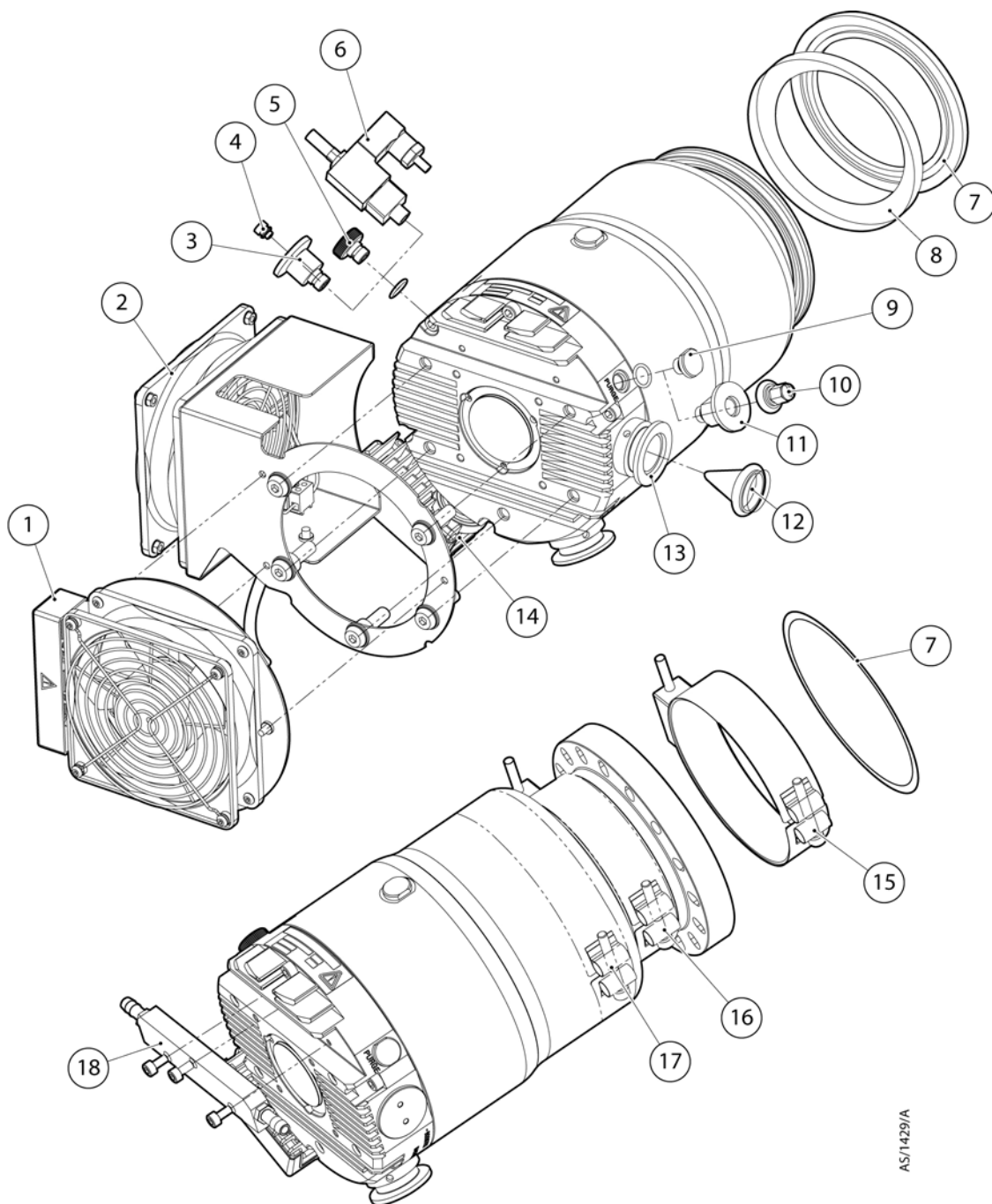

- | | |
|--|------------------------------------|
| 1. ACX400 axial air cooling accessory | 10. PRX purge restrictor |
| 2. ACX400 radial air cooling accessory | 11. DN10W adaptor |
| 3. DN10NW vent port adaptor | 12. Booster-port strainer and seal |
| 4. VRX vent restrictor | 13. Booster inlet port |
| 5. Manual vent valve (fitted) | 14. EXDC controller |
| 6. TAV solenoid valve | 15. Bakeout band (BX250 shown) |
| 7. Inlet-flange O-ring/ gasket | 16. BX250 bakeout band position |
| 8. Inlet screens (fitted) | 17. BX450 bakeout band position |
| 9. Purge plug (fitted) | 18. WCX water-cooler |

AS/1429/A

Figure 4 - Accessories for EXTPX split flow pumps

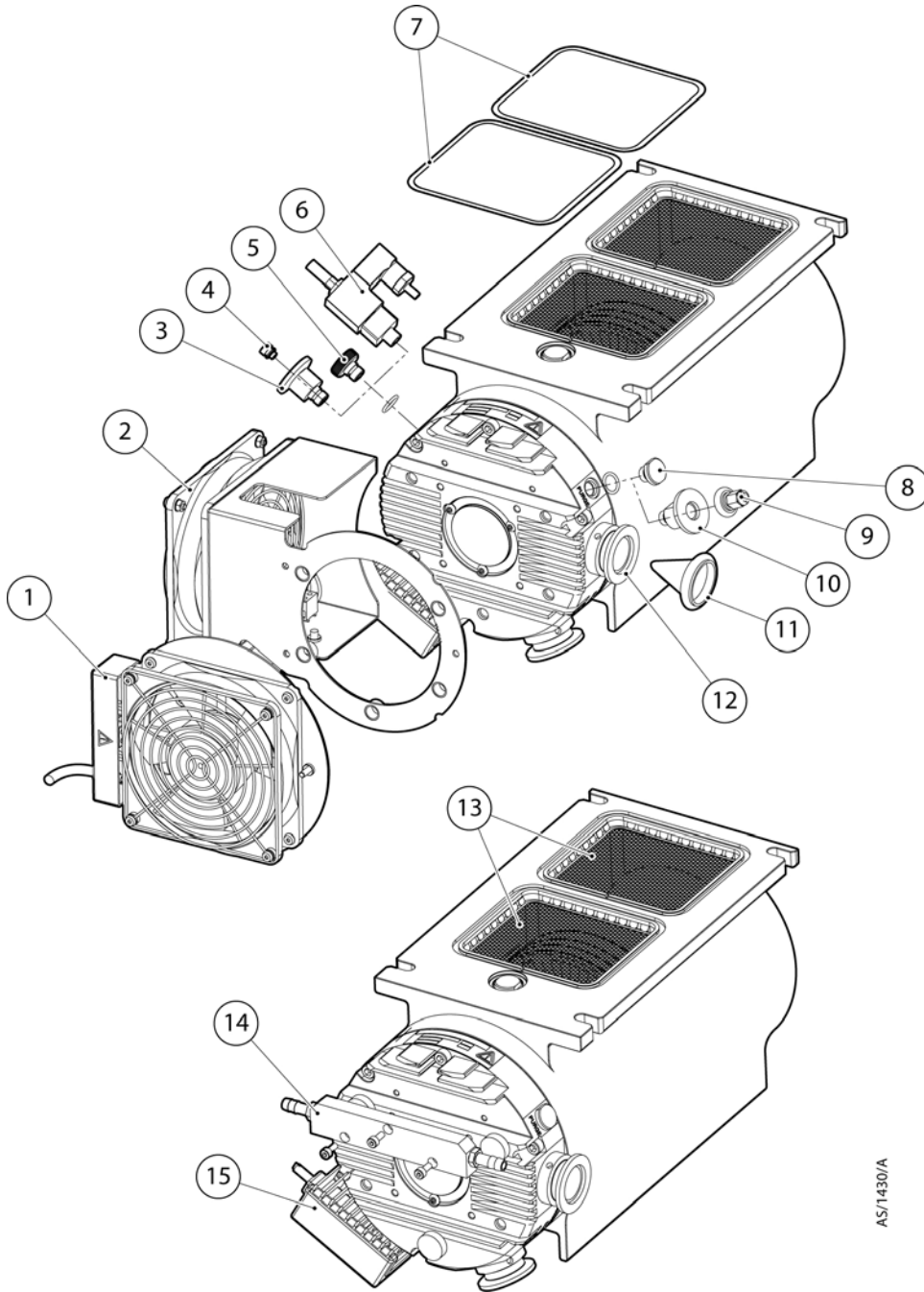

AS/1430/A

- | | |
|--|------------------------------------|
| 1. ACX400 axial air cooling accessory | 9. PRX purge restrictor |
| 2. ACX400 radial air cooling accessory | 10. DN10W adaptor |
| 3. DN10NW vent port adaptor | 11. Booster-port strainer and seal |
| 4. VRX vent restrictor | 12. Booster inlet port |
| 5. Manual vent valve (fitted) | 13. Inlet screens (fitted) |
| 6. TAV solenoid valve | 14. WCX water-cooler |
| 7. Inlet-flange O-rings | 15. EXDC controller |
| 8. Purge plug (fitted) | |

2 BX bakeout band

2.1 Description

You can fit an Edwards BX bakeout band to an EXT pump to increase the rate of degassing of the pump body, to achieve faster pump down and lower ultimate pressure. You should only fit BX bakeout bands to CF flanged pumps intended for use at ultra high vacuum.

BX bakeout bands are available for use with electrical supplies of 110 or 240 V a.c. and can be powered from a rear panel socket on the EXC Controller, from a rear panel socket on a TIC Relay Box, or from any suitable electrical supply.

2.2 Technical data

Table 1 - BX bakeout band technical data

| | | | | |
|-------------------------------|--|-------|-------|--------------------|
| Electrical supply | 110 to 120 V a.c., 50/60 Hz or 200 to 240 V a.c., 50/60 Hz | | | |
| Cable length | 3 m | | | |
| Termination | 3-pin IEC reverse configuration plug | | | |
| Typical operating temperature | 80 °C (measured on the pump envelope above the bakeout band) | | | |
| Pollution degree | EN61010 Part 1, Category 2 | | | |
| Equipment type | Fixed equipment for indoor use only | | | |
| | BX70 | BX250 | BX450 | BX501 |
| Approximate mass (kg) | 0.47 | 0.55 | 0.70 | 0.75 |
| Nominal diameter (mm) | 78 | 119 | 140 | 188 |
| Width of band (mm) | 25 | 30 | 40 | 40 |
| Input power (W) | 30 | 60 | 80 | 100 |
| Fuse rating | | | | |
| 110 to 120 V | 0.5 A | 1.0 A | 1.0 A | 1.0 A |
| 200 to 240 V | 0.5 A | 0.5 A | 0.5 A | 0.5 A |
| Item Numbers | | | | |
| Model | To fit pump | | | Item Number |
| BX70/110 V | EXT70/70H/70Hi/75DX/75iDX | | | B580-52-040 |
| BX250/110 V | EXT250/250H/250Hi/250M, EXT255H/255Hi/255DX/255iDX | | | B580-52-041 |
| BX450/110 V | EXT406PX | | | B580-52-043 |
| BX501/110 V | EXT555H/555HF/555Hi/555H _E /EXT556 | | | B580-52-044 |
| BX70/240 V | EXT70/70H/70Hi/75DX/75iDX | | | B580-52-060 |
| BX250/240 V | EXT250/250H/250Hi/250M, EXT255H/255Hi/255DX/255iDX | | | B580-52-061 |
| BX450/240 V | EXT406PX | | | B580-52-063 |
| BX501/240 V | EXT555H/555HF/555Hi/555H _E /EXT556 | | | B580-52-064 |

2.3 Installation

2.3.1 Unpack and inspect

Remove all packing materials and protective covers and check the BX bakeout band.

If the BX bakeout band is damaged, notify your supplier and the carrier in writing within three days; state the Item Number of the BX bakeout band together with your order number and your supplier's invoice number. Retain all packing materials for inspection. Do not use the BX bakeout band if it is damaged.

2.3.2 Fit the BX bakeout band to the pump



WARNING

Before you install the accessory, ensure that you switch off the pump and isolate the controller/podule as described below.

1. Switch off the pump, isolate the pump controller from the electrical supply (on an EXT DX pump, isolate the podule from the electrical supply), and wait until the pump has stopped rotating.
2. Fit the BX bakeout band over the pump-body below the inlet-flange at the position shown by [Figure 1](#), item 16 or [Figure 2](#), item 12.
3. Tighten the clamping-screw.

2.3.3 Electrical connection to an EXC controller

The BX bakeout band is supplied with a 3 metre cable terminated with an IEC connector. The connector fits the rear panel socket on the EXC120, EXC300 and EXC300M Controllers.

If you have an EXDC or EXC100 Controller, or you have an EXT DX pump, you must use either a TIC Relay Box as described in [Section 2.3.4](#), or an independent electrical supply as described in [Section 2.3.5](#).

1. Check that the rating of the fuse fitted in the rear-panel of the EXC Controller corresponds to the fuse rating stamped on the BX bakeout band. (Two spare fuses are supplied with the BX bakeout band).
2. Insert the connector into the socket in the rear of the EXC Controller.
3. Refer to the EXC Controller instruction manual to complete the installation.

2.3.4 Electrical connection to a TIC relay box

Refer to the TIC Relay Box instruction manual for information on how to fit the correct fuse, and how to connect the bakeout band to the TIC Relay Box.

2.3.5 Electrical connection to an independent electrical supply

If necessary, you can connect the BX bakeout band directly to an appropriate electrical supply.

Always ensure that the electrical supply to the BX bakeout band is interlocked so that it is automatically switched off whenever the EXT pump operates below normal speed. Check that the rating of the fuse fitted within your electrical supply corresponds to the fuse rating stamped on the BX bakeout band.

2.4 Operation



WARNING

Do not operate the BX bakeout band when it is not installed on a pump. Without the cooling effect of the pump-body, the temperature of the band can rise to 300 °C with the danger of insulation breakdown and fire.



WARNING

Do not touch the BX bakeout band when it is switched on, as it can get very hot during operation.

CAUTION

Do not allow the temperature of the EXT pump envelope to rise above 100 °C, whether you use the BX bakeout band on its own or with bakeout heaters on your vacuum system.

When you use the bakeout band, ensure that there is adequate cooling for the pump and adequate ventilation for the bakeout band.

If you use an EXC120, EXC300 or EXC300M Controller to power the BX bakeout band, the operation of the BX bakeout band is controlled from the 'Heater' switch on the front panel of the EXC Controller. The 'Heater' switch is interlocked with the 'Start/Reset' switch and the pump 'Normal' indication; the bakeout band is switched off automatically if the EXT pump is overloaded.

Refer to the EXC Controller instruction manual for additional information.

If you have connected the bakeout band to a TIC Relay Box, refer to the TIC instruction manual for instructions on how to use the TIC to control the operation of the bakeout band.

3 ACX air-cooler

3.1 Description

An ACX air-cooler is used when a suitable cooling-water supply is not available for the pump or for a mobile pumping system. The ACX air-cooler is an enclosed electric fan and fixing bracket assembly which is easily fitted to bolt holes in the base of the pump. The ACX air-cooler has a 24 V d.c. motor which can be powered from a rear panel socket on the EXC Controller, an EXT DX podule, a TIC, or any suitable electrical supply.

All air-coolers are supplied with side-mounting brackets. The ACX250 is also supplied with an axial-mounting bracket for optional use with EXT250M pumps only.

The ACX400 air-coolers are available for both axial and radial mounting. It is possible to use both variants simultaneously if so desired and space allows. TICs can provide power for one fan only.

Refer to the EXT pump instruction manual to check the suitability of air cooling in your particular application.

3.2 Technical data

Table 2 - ACX air-cooler technical data

| | | | | | | | |
|--------------------------|--|--------|---------|------------------|-----------------|--------|----------------|
| Electrical supply | 20 to 28 V d.c. | | | | | | |
| Cable type and length | 2-core with screen, 3 m long | | | | | | |
| Cable cores | Red (positive), black (negative): unterminated, screen terminated with ring terminal | | | | | | |
| Pollution degree | EN61010 Part 1 Category 2 | | | | | | |
| Equipment type | Fixed equipment for indoor use only | | | | | | |
| | ACX75 | ACX250 | ACX250H | ACX400 Radial | ACX400 AXIAL | ACX500 | ACX555 |
| Dimensions: see Figure | 5 | 7 | 10 | 12 | 14 | 17 | 19 |
| Approximate mass (kg) | 0.38 | 0.85 | 0.50 | 0.70 | 0.45 | 0.64 | 1.28 |
| Rated current (mA) | 120 | 120 | 100 | 110 | 110 | 100 | 250 |
| Noise level at 1 m (dBA) | < 45 | < 45 | < 45 | < 45 | < 45 | < 45 | < 45 |
| Item Numbers | | | | | | | |
| Model | To fit pump | | | | | | Item Number |
| ACX75 | EXT70/70H/70Hi/75DX/75iDX | | | | | | B580-53-075 |
| ACX250 | EXT250M | | | | | | B580-53-150 |
| ACX250H | EXT250/250H/250Hi, EXT255H/255Hi/255DX/255iDX | | | | | | B580-53-160 |
| ACX400 radial | EXT406PX/EXT400/200/(30i)PX | | | | | | B580-53-455 |
| ACX400 axial | EXT406PX/EXT400/200/(30i)PX | | | | | | B580-53-405 |
| ACX500 | EXT351/501 | | | | | | B580-53-200 |
| ACX555 | EXT555H/555HF/555Hi | | | | | | B580-53-561 |

Figure 5 - ACX75 air-cooler dimensions (mm)

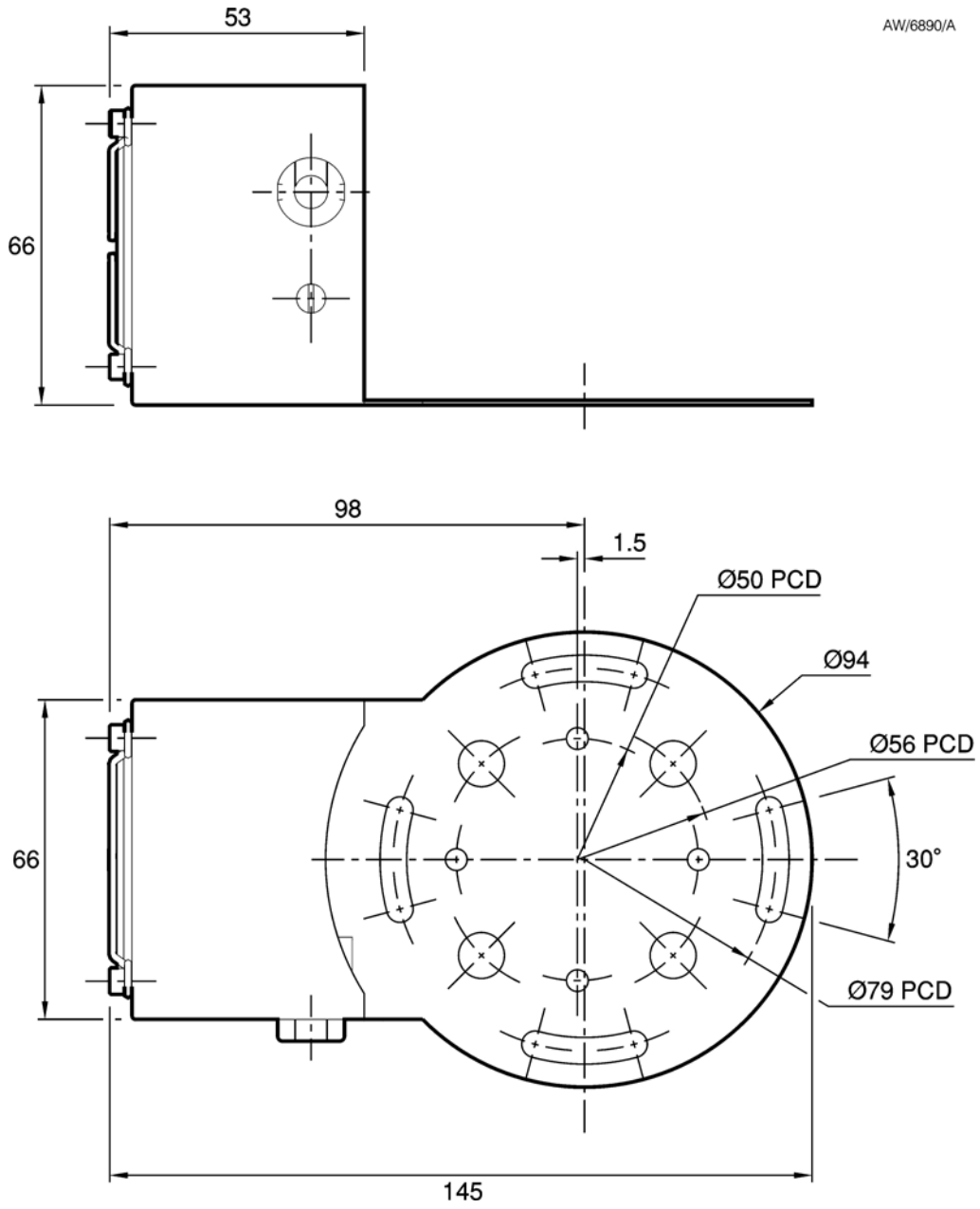
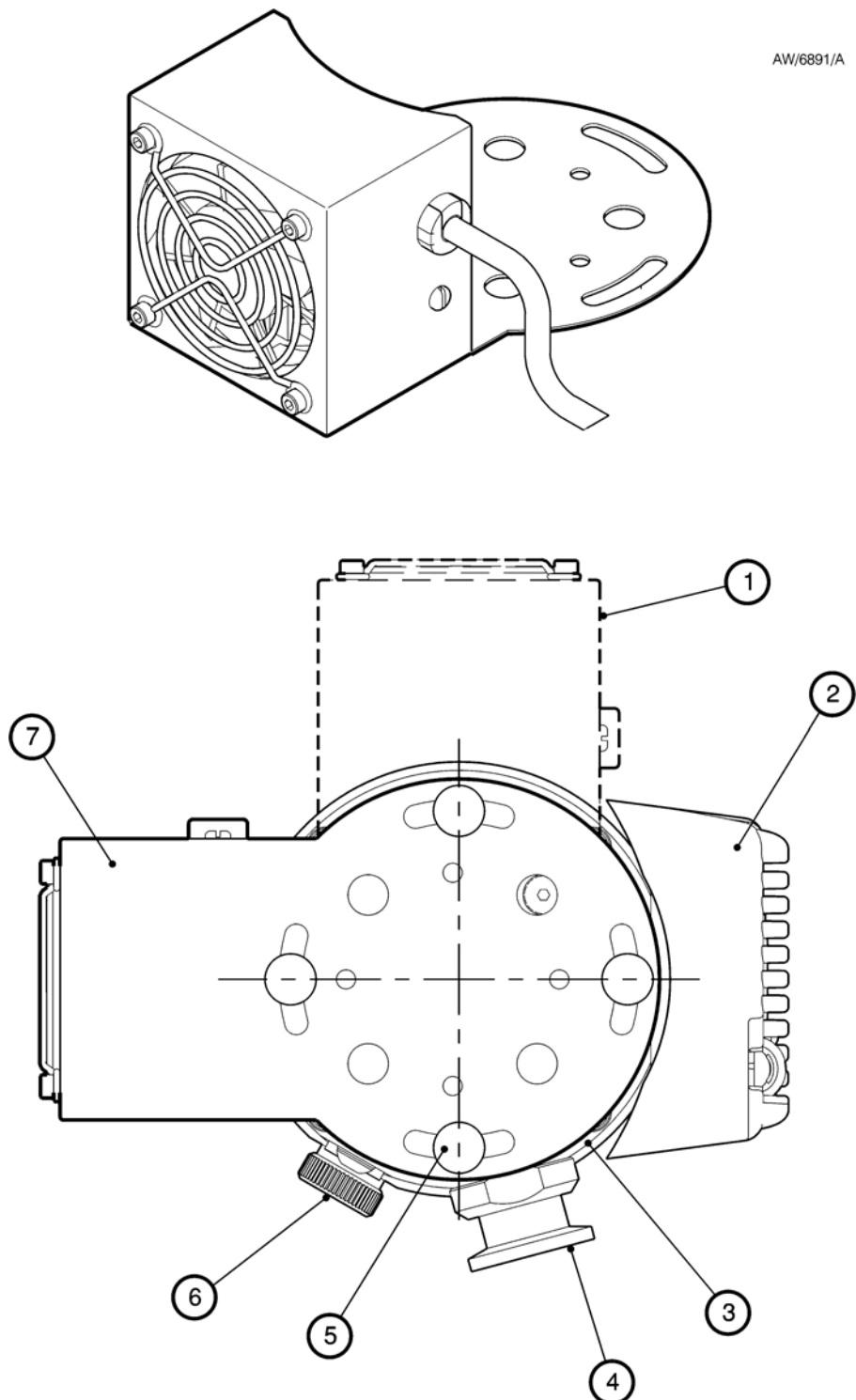

Figure 6 - ACX75 air-cooler installation (shown fitted to EXT75DX pump)



- | | |
|----------------------------------|--|
| 1. Recommended mounting position | 5. Fixing screws and washers: M4 x 5 (4 off) |
| 2. Podule | 6. Manual vent-valve |
| 3. EXT75DX pump-base | 7. ACX75 mounting bracket* |
| 4. Pump backing-port | |

* Shown in alternative mounting position

Figure 7 - ACX250 air-cooler dimensions (mm)

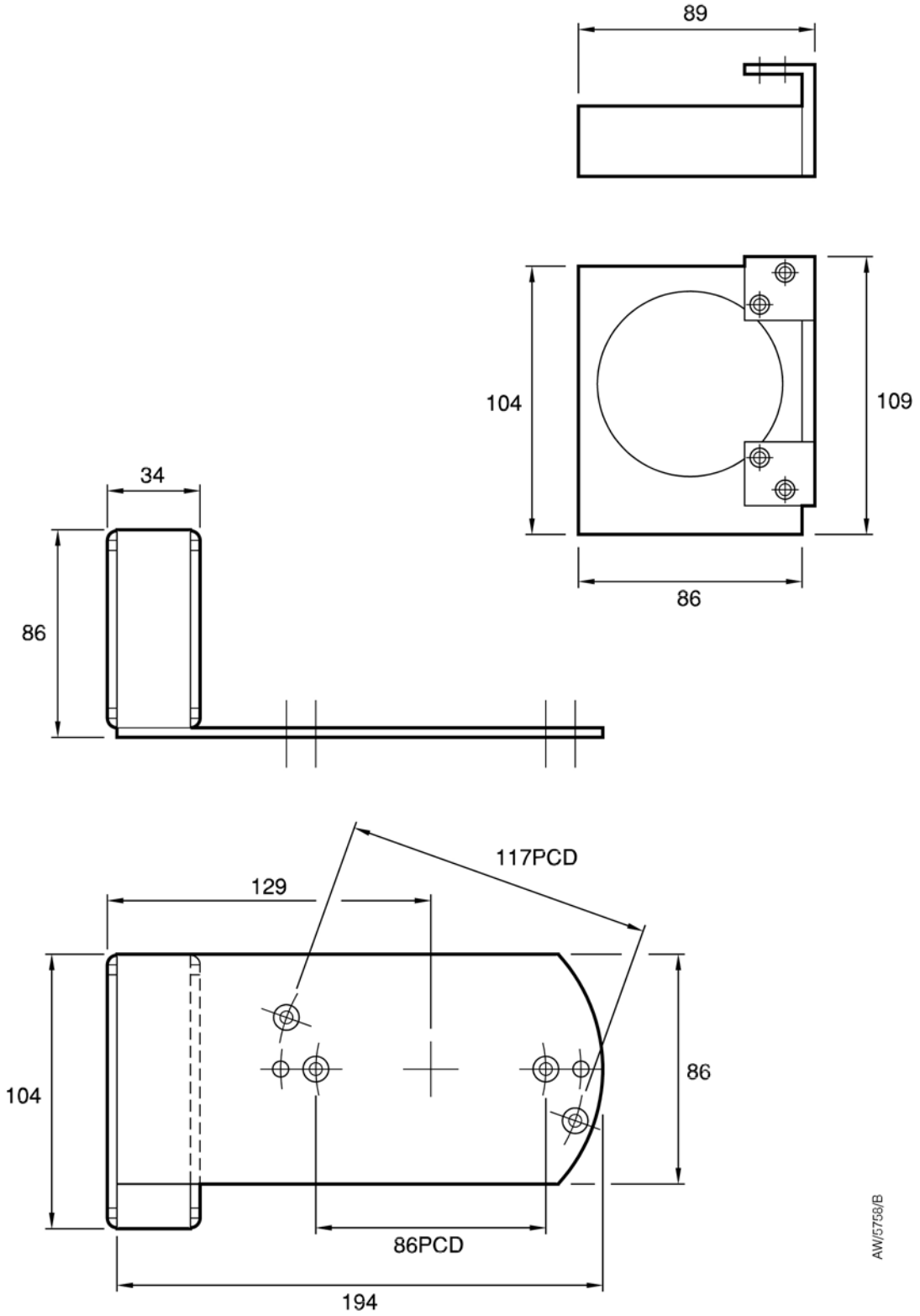

AW/5756/B

Figure 8 - ACX250 air-cooler installation (shown fitted to EXT250M pump)

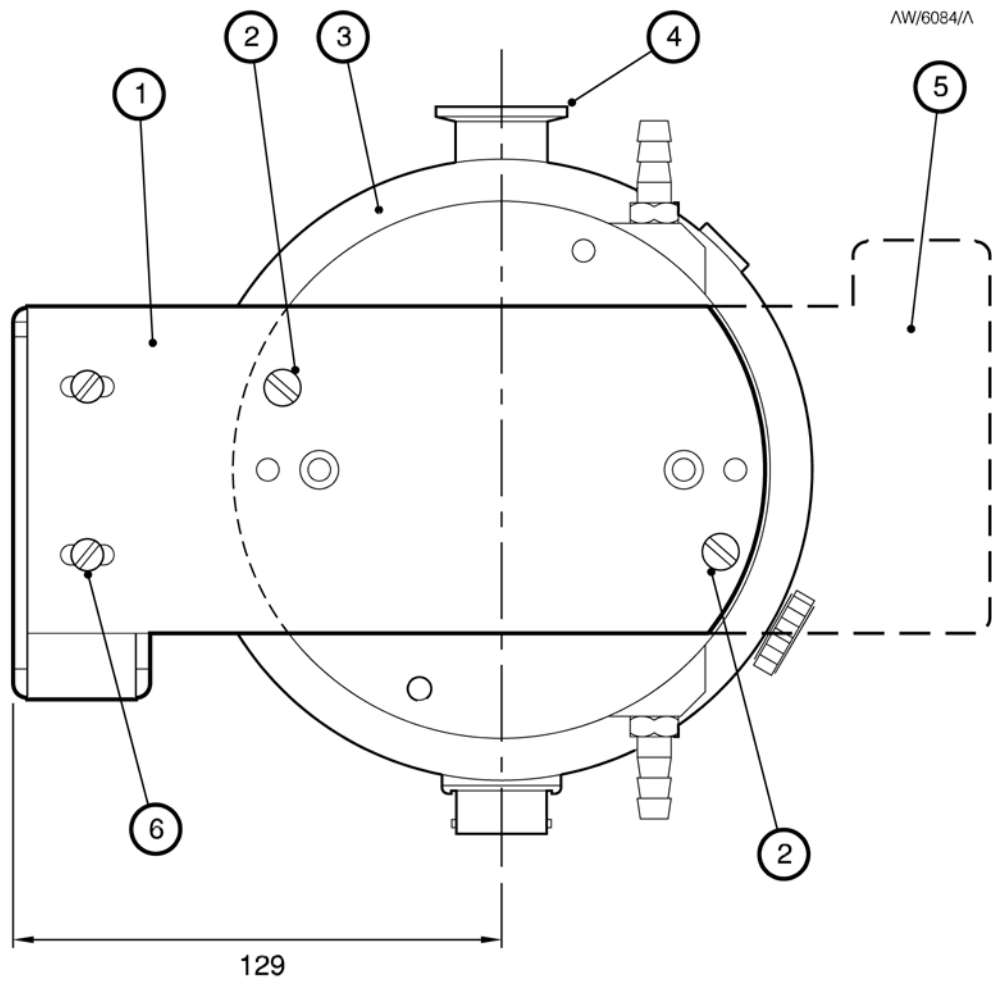

- | | |
|----------------------------------|--|
| 1. ACX250 mounting bracket | 4. Pump outlet-port |
| 2. Fixing screws: M5 x 5 (2 off) | 5. Alternative mounting position |
| 3. EXT250M pump-base | 6. Fan/bracket fixing screws: M5 x 5 (2 off) |

Figure 9 - ACX250 air-cooler axial installation (shown fitted to EXT250M pump)

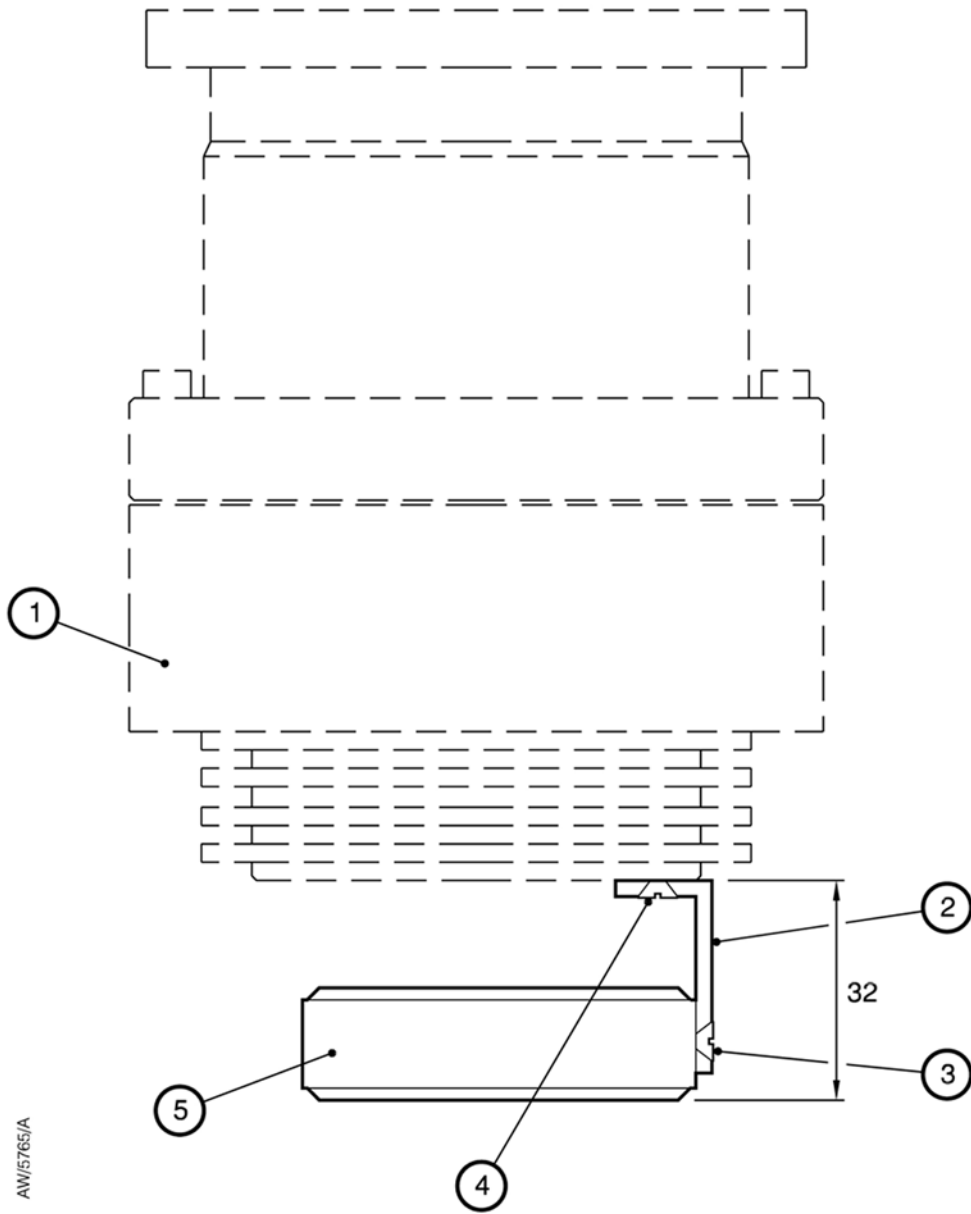

- 1. EXT250M pump
- 2. ACX250 axial mounting bracket
- 3. Screws: M5 x 5 (2 off)
- 4. Screws: M5 x 5 (2 off)
- 5. ACX250 air-cooler

Figure 10 - ACX250H air-cooler dimensions (mm)

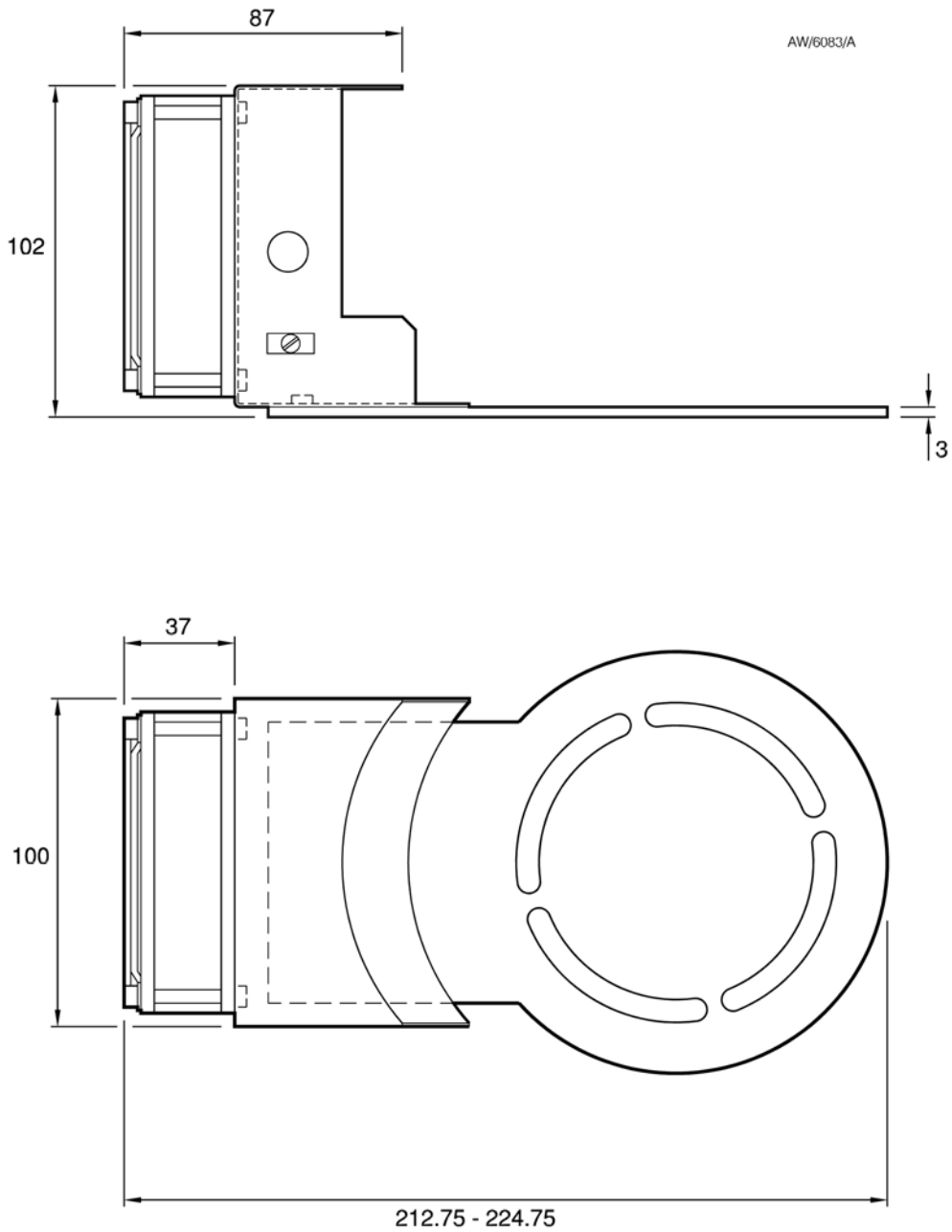
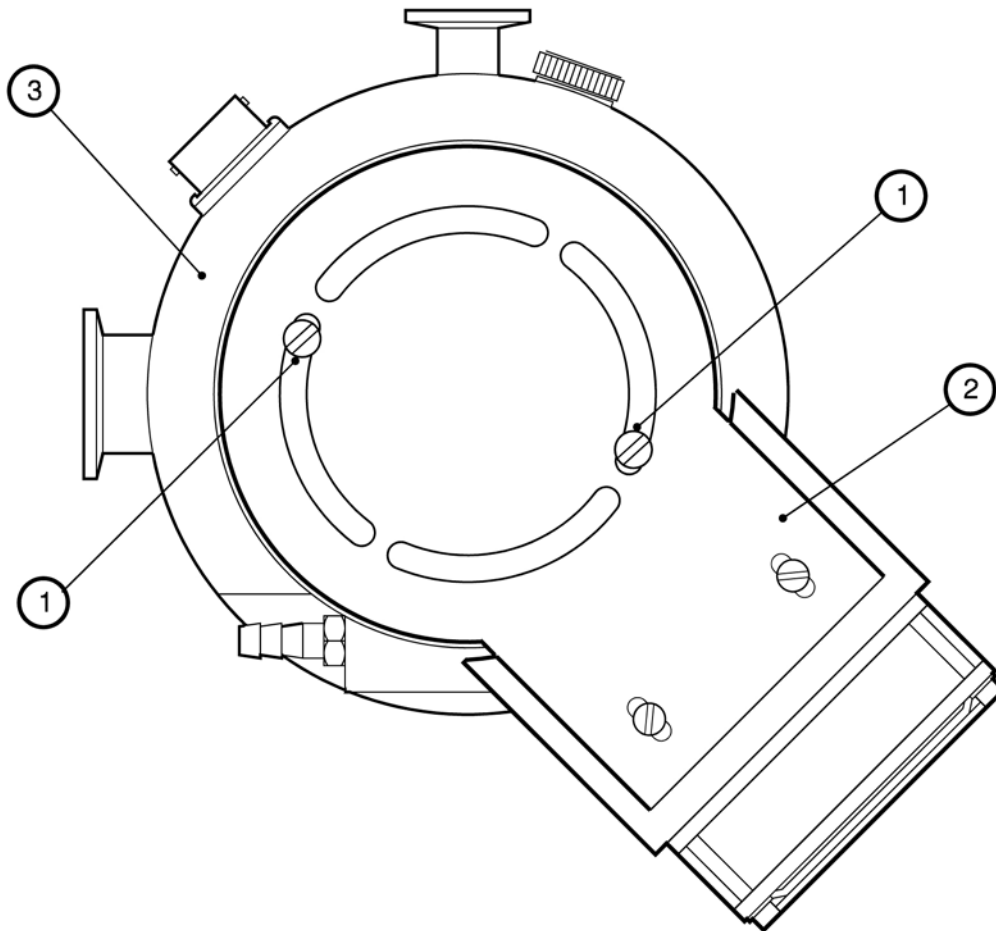
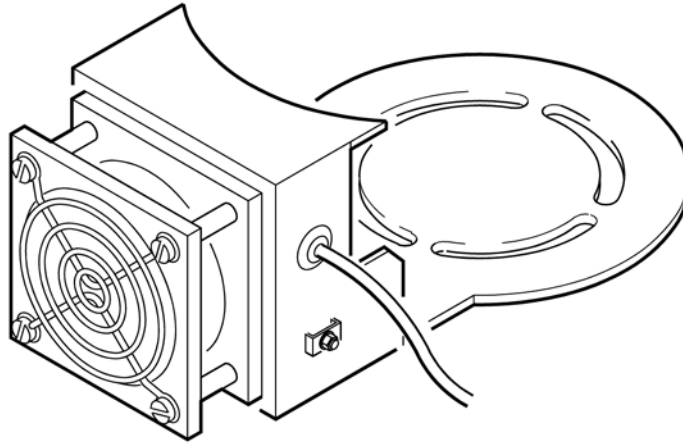

Figure 11 - ACX250H air-cooler installation (shown fitted to EXT255Hi pump)

AW/6085/A



- 1. M5 fixing screws (length dependent on pump): 2 off
- 2. ACX250H mounting bracket
- 3. EXT250H/Hi pump-base

Figure 12 - ACX400 radial air-cooler dimensions (mm)

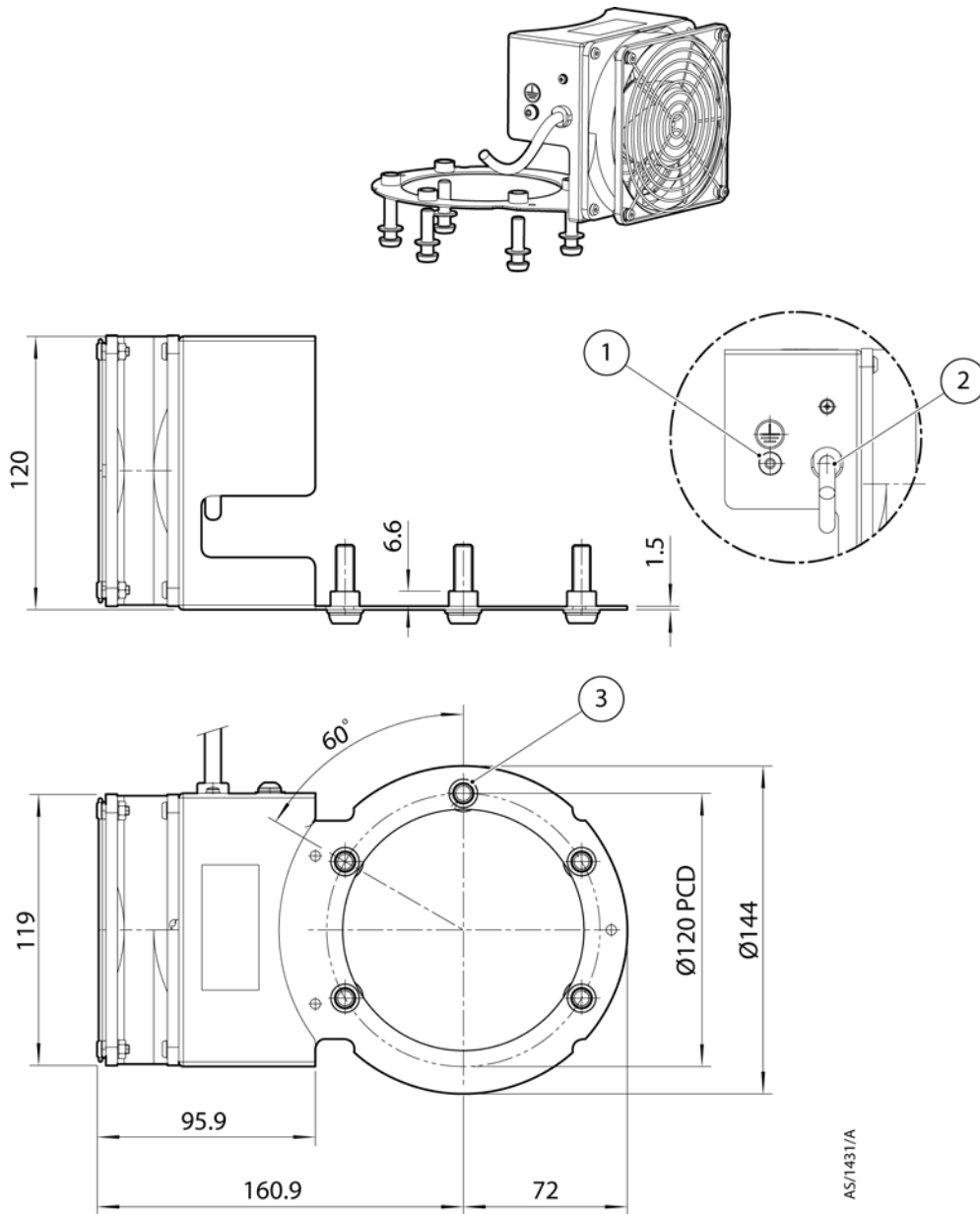

AS/1431/A

1. Earth screw (M5 x10)
2. 24 V power cable
3. Mounting screws (M8 x 30) x 5 with washers

Figure 13 - ACX400 radial air-cooler installation

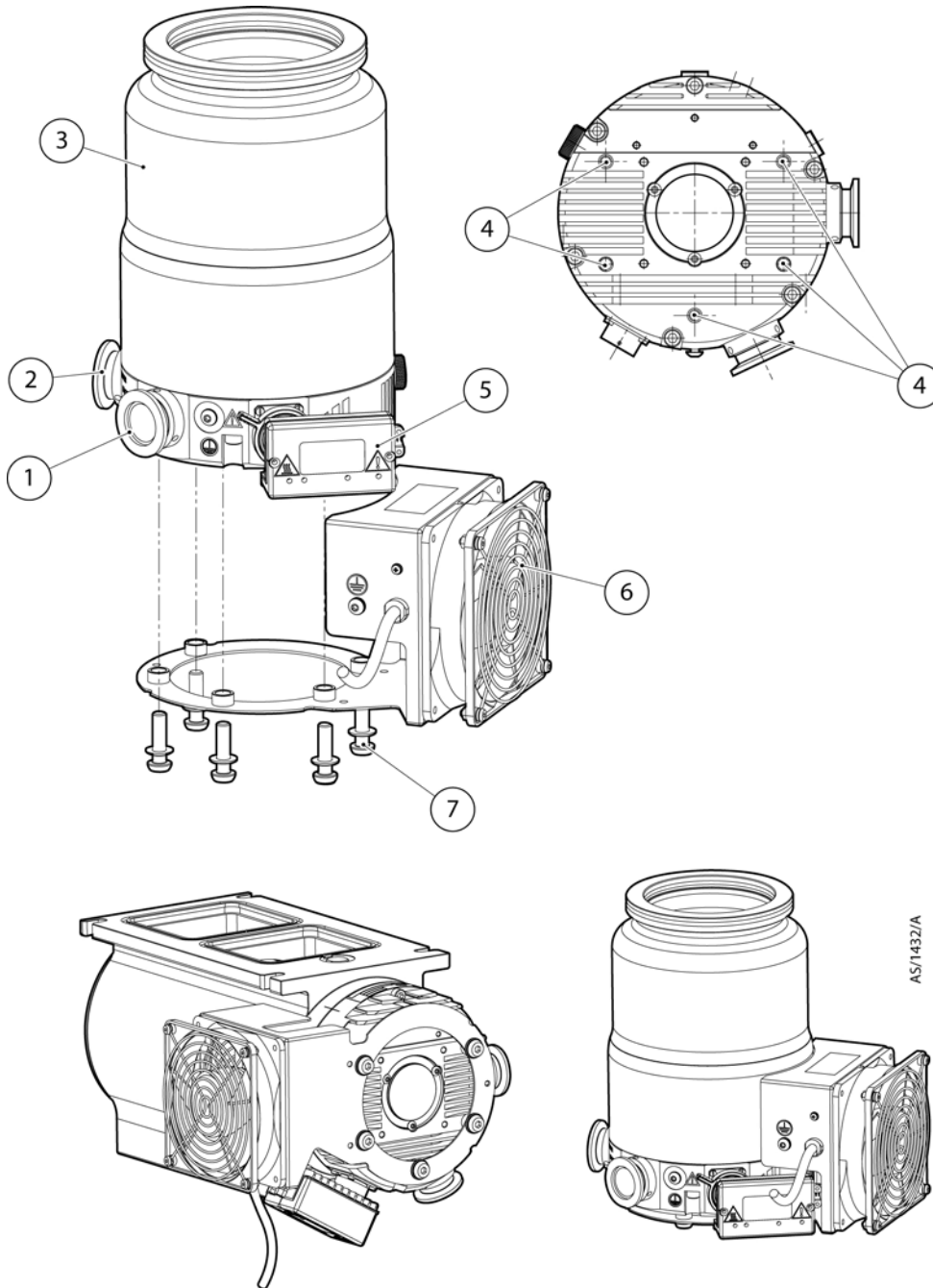

- 1. Pump backing port
- 2. Pump booster port
- 3. EXT406PX
- 4. Radial fan mounting screws (5 x M8 holes)
- 5. EXDC drive module
- 6. ACX400 air-cooler
- 7. Mounting screws (M8 x 30) and washers

Figure 14 - ACX400 axial air-cooler dimensions (mm)

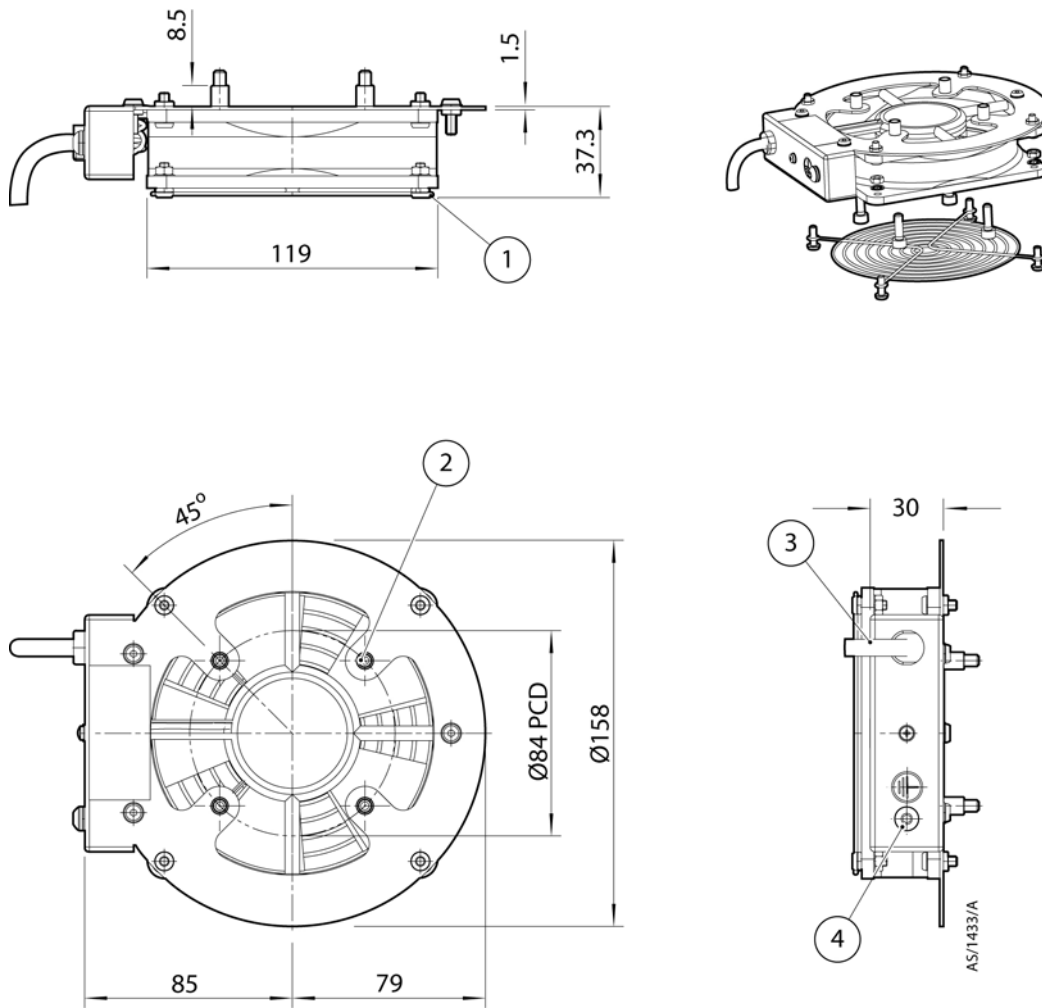

1. Removable screen for mounting
2. Mounting screws (M5 x 16) x 4
3. 24 V power
4. Earth screw (M5 x 10)

Figure 15 - ACX400 axial air-cooler installation

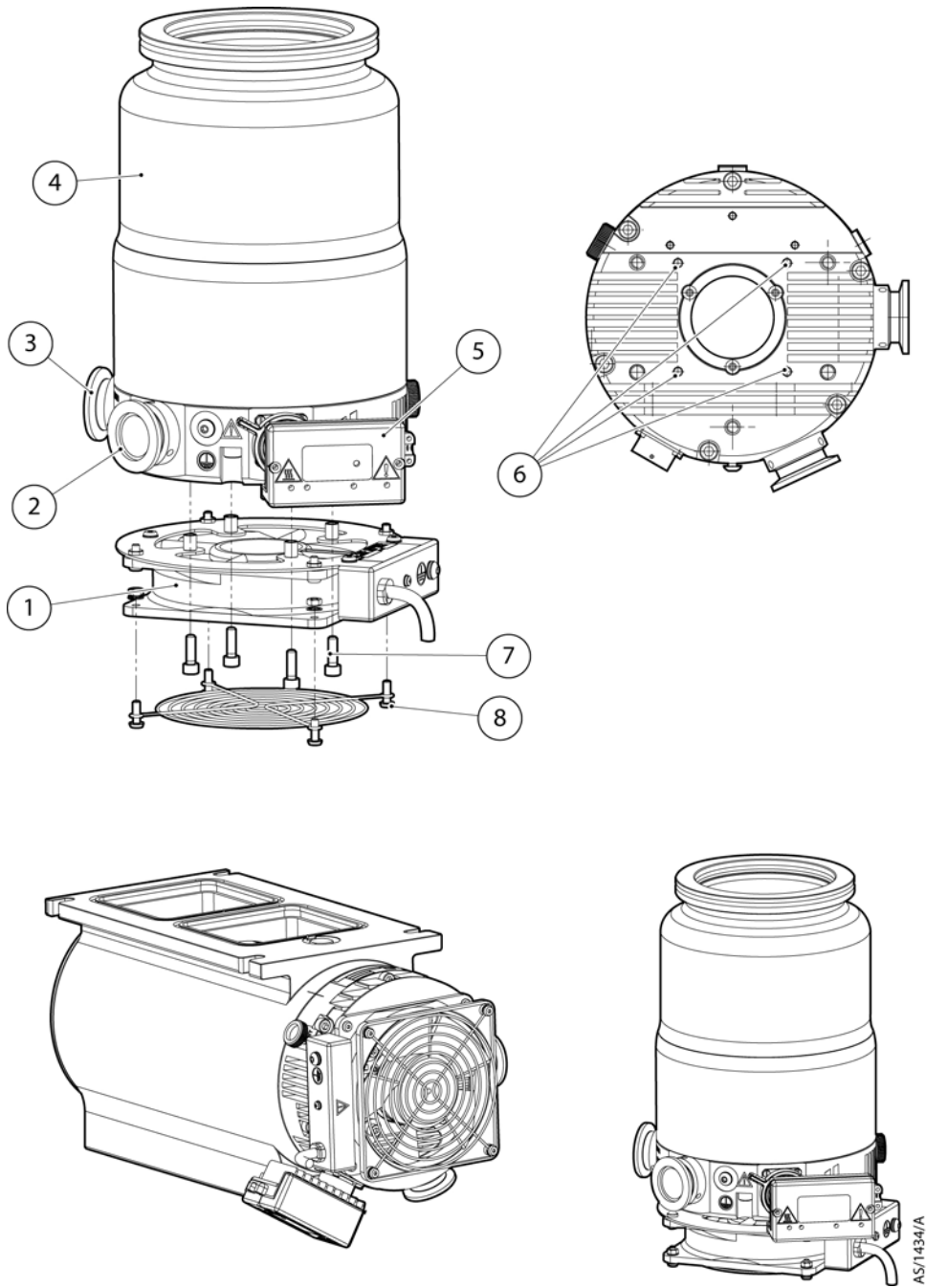

- 1. ACX400 air-cooler
- 2. Pump backing port
- 3. Pump booster port
- 4. EXT406PX
- 5. EXDC drive module
- 6. Axial fan fixings (4 x M5 holes)
- 7. Fixing screws (M5 x 16)
- 8. Air-cooler grill

AS/1434/A

Figure 16 - ACX400 axial and radial air-cooler combination installation

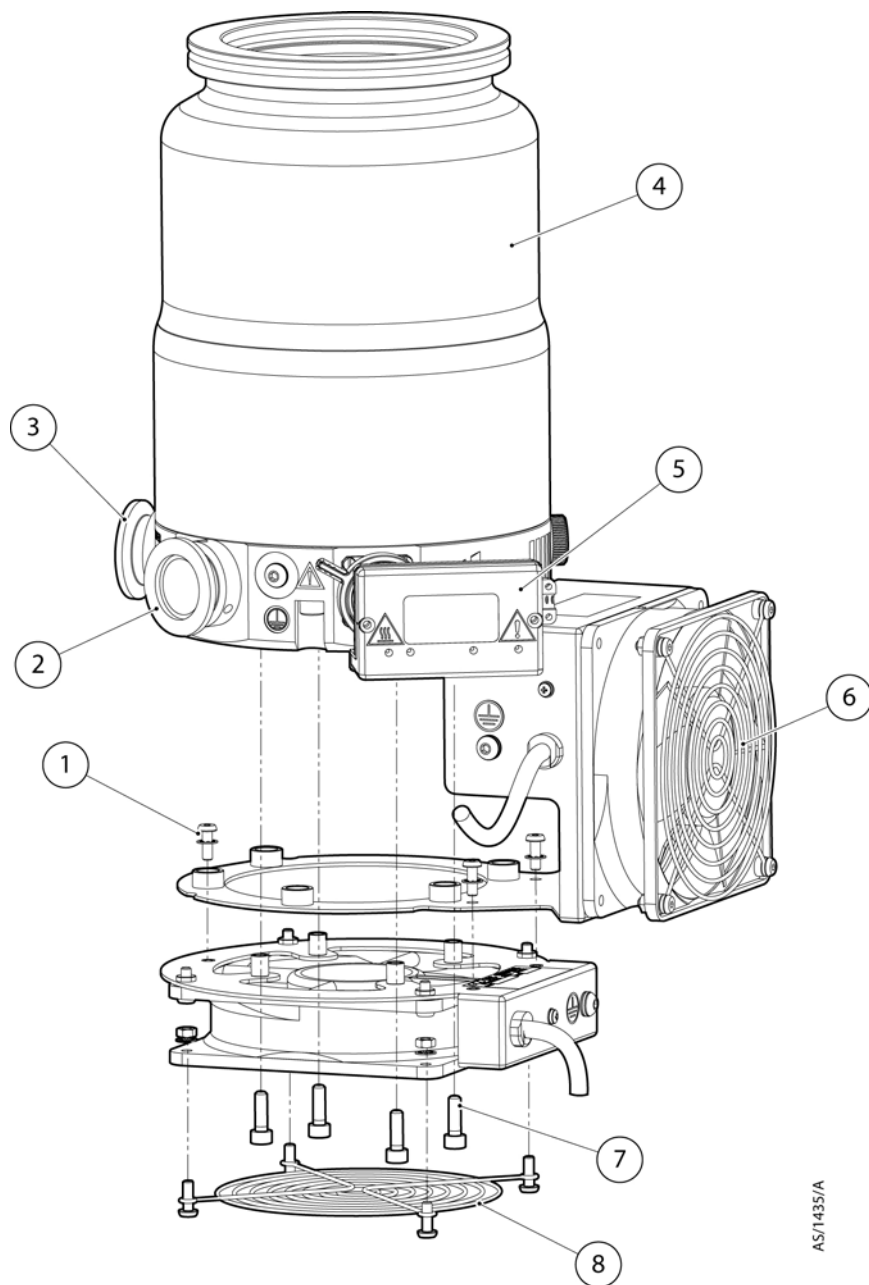

- | | |
|---|--|
| 1. Fan-fan assembly fixings (M4 x 12) x 3 | 5. EXDC drive module |
| 2. Pump backing port | 6. ACX400 air-cooler |
| 3. Pump booster port | 7. Assembly-body fixings (M8 x 30) x 4 |
| 4. EXT406PX | 8. Removable protective grill |

AS/1435/A

Figure 17 - ACX500 air-cooler dimensions (mm)

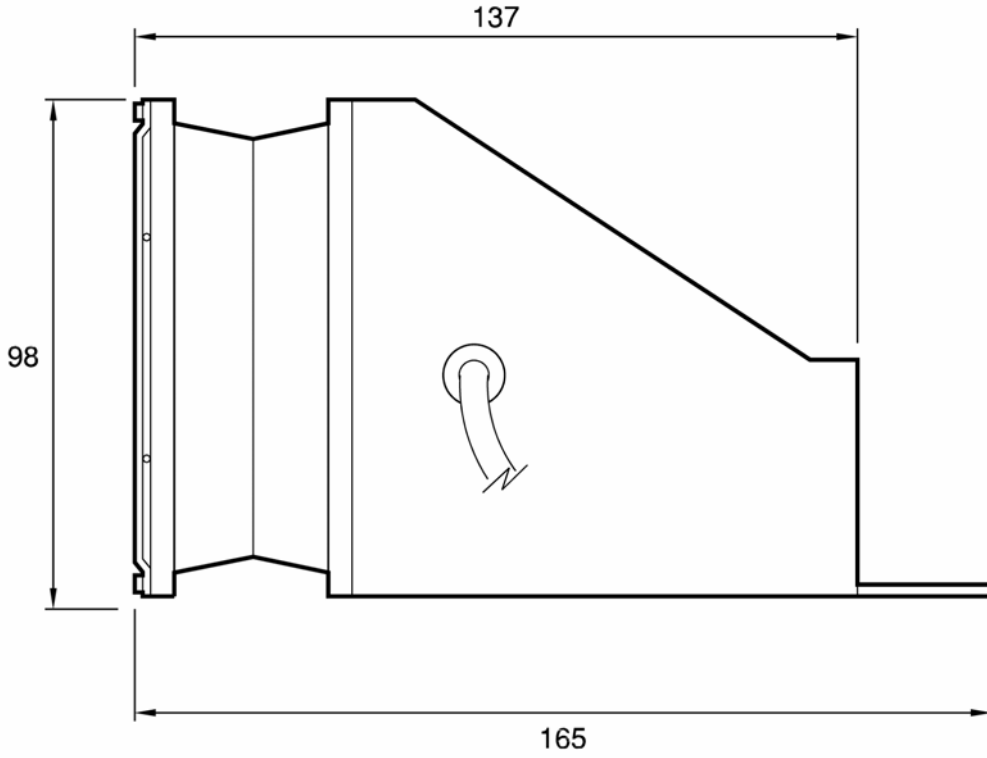

AW/5760/A

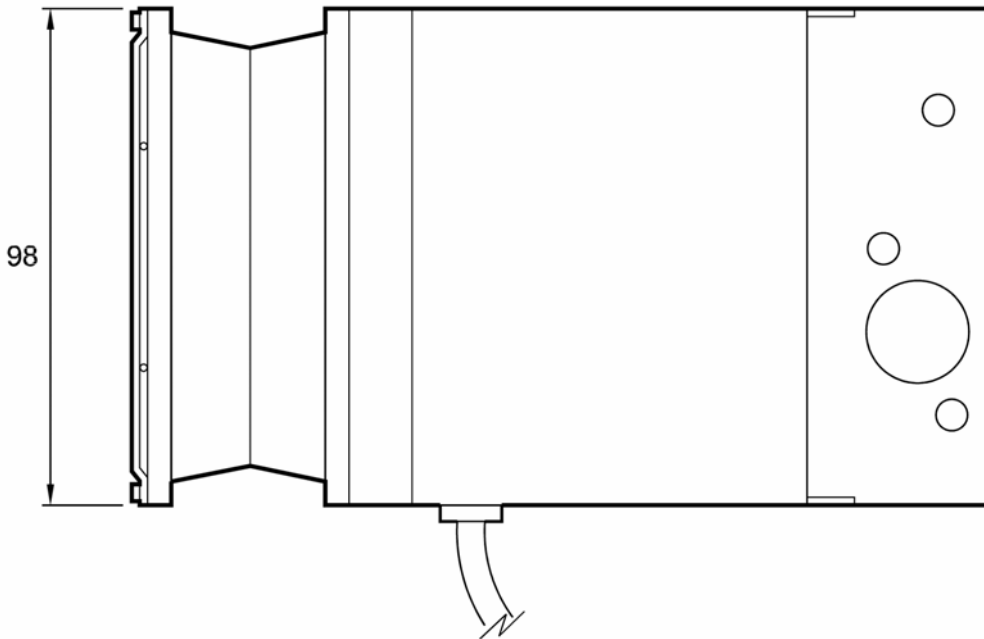
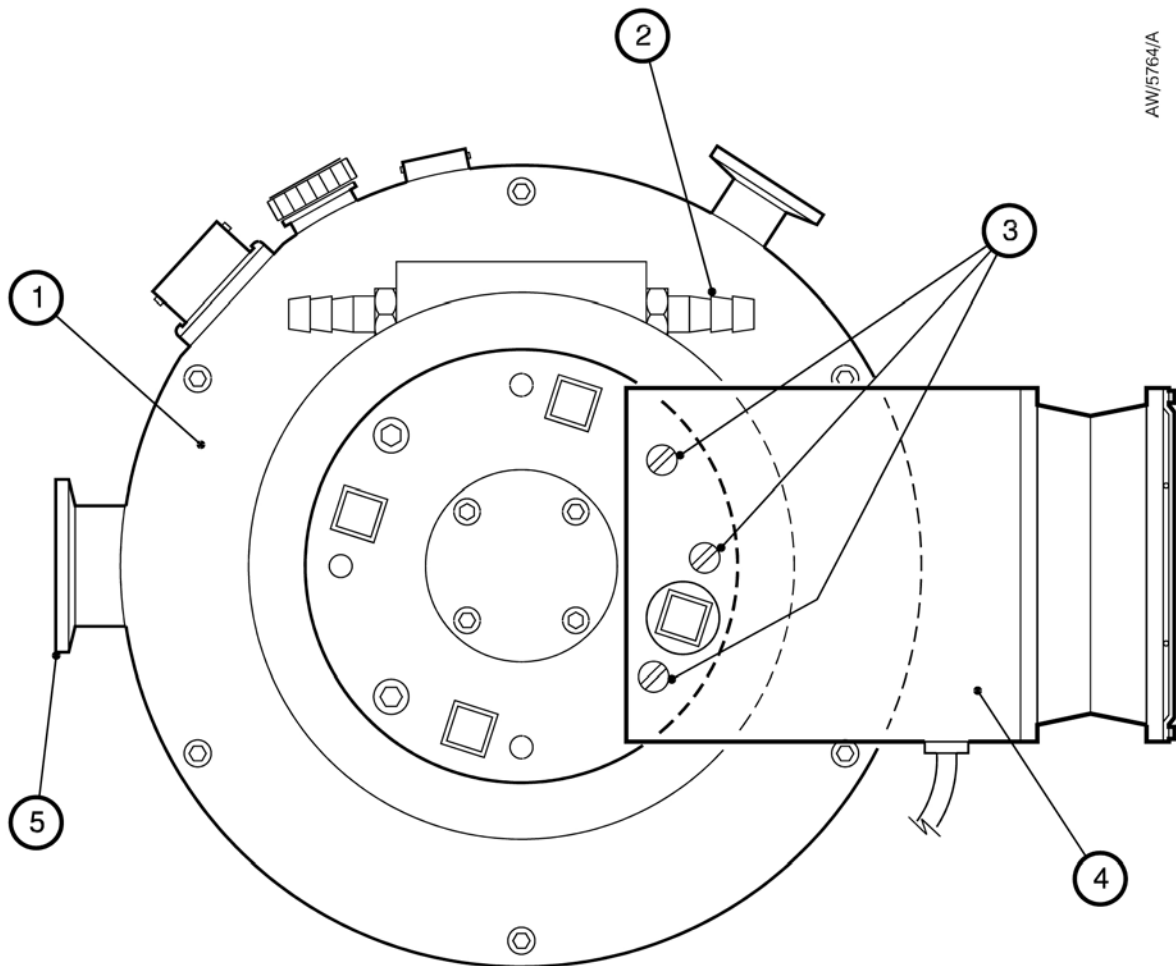

Figure 18 - ACX500 air-cooler installation (shown fitted to EXT501 pump)



AW/5764/A

1. EXT501 pump-base
2. Pump water-cooling connections
3. Screws: M5 x 5 (3 off)
4. ACX500 mounting bracket
5. Pump outlet-port

Figure 19 - ACX555 air-cooler dimensions (mm)

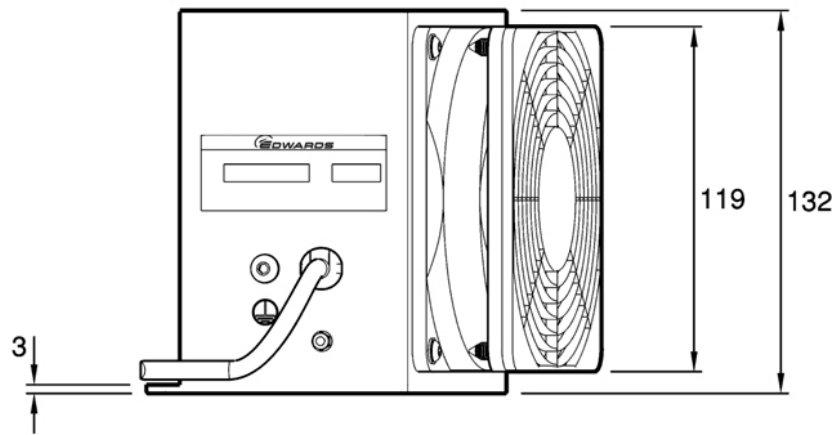
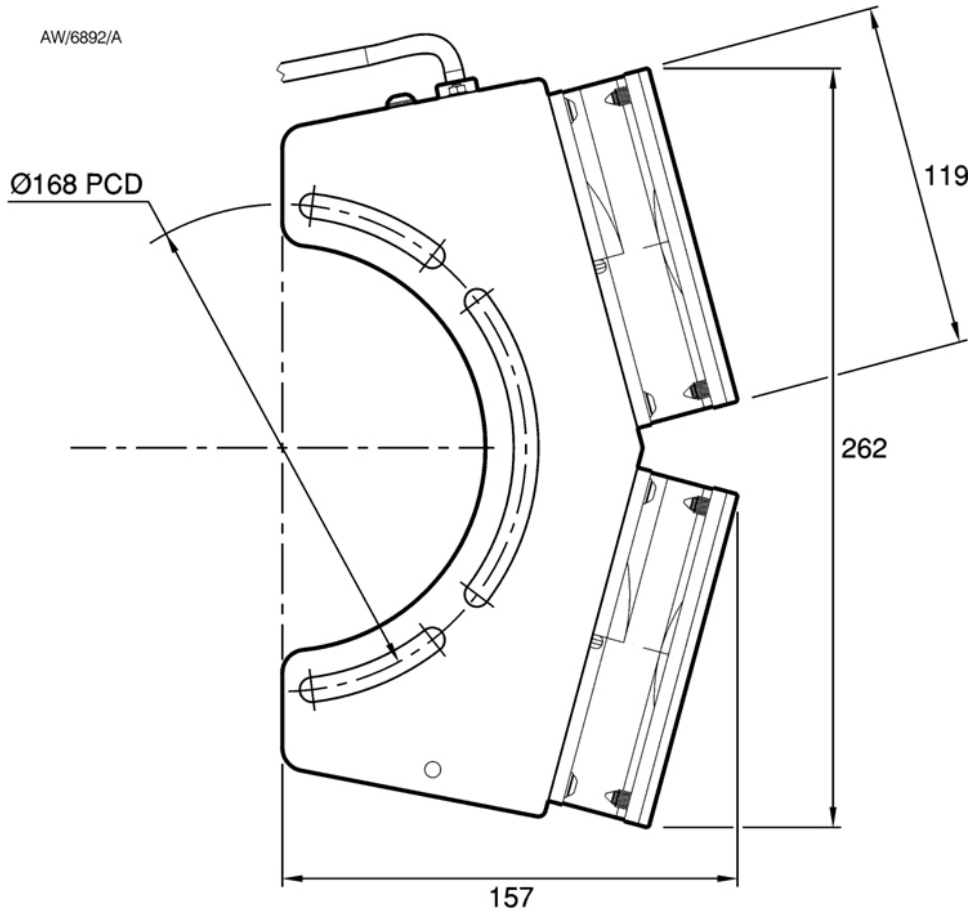
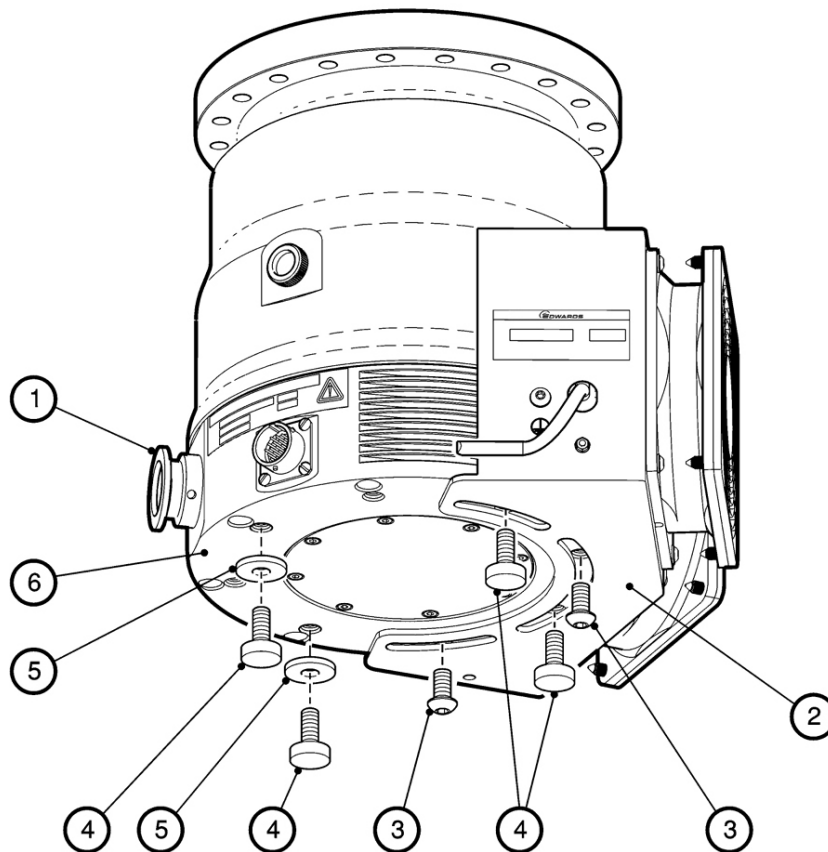
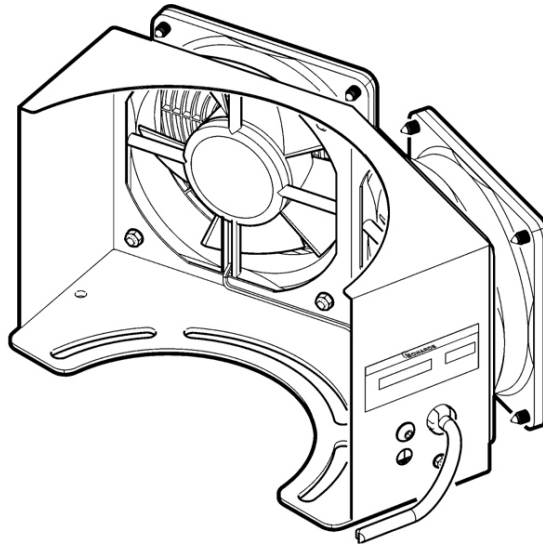

Figure 20 - ACX555 air-cooler installation (shown fitted to EXT555H pump)

AW/6893/A



- | | |
|----------------------------|-------------------------------|
| 1. Pump backing-port | 4. Pump mounting feet (4 off) |
| 2. ACX555 air-cooler | 5. Spacers (4 off) |
| 3. Screws: M8 x 25 (2 off) | 6. EXT555H pump-base |

3.3 Installation

3.3.1 Unpack and inspect

Remove all packing materials and protective covers and check the ACX air-cooler.

If the ACX air-cooler is damaged, notify your supplier and the carrier in writing within three days; state the Item Number of the ACX air-cooler together with your order number and your supplier's invoice number. Retain all packing materials for inspection. Do not use the ACX air-cooler if it is damaged.

3.3.2 Side (or radial) mounting



WARNING

Before you install the accessory, ensure that you switch off the pump and isolate the controller/podule as described below.

1. Switch off the pump, isolate the pump controller from the electrical supply (on an EXT DX pump, isolate the podule from the electrical supply), and wait until the pump has stopped rotating.
2. Continue at [Step 3](#) in the appropriate [EXT75DX pumps](#), [EXTPX pumps](#), [EXT555H pumps](#) or [Other pumps](#) procedure below, depending on the type of your pump.

3.3.2.1 EXT75DX pumps

3. Unscrew the rubber pump mounting feet.
4. Fit the ACX75 air-cooler mounting bracket to the base of the pump, and refit the mounting feet to secure the mounting bracket in place.

3.3.2.2 EXTPX pumps

Refer to [Figure 12](#) and [13](#).

3. Unscrew the rubber pump mounting feet.
4. The ACX400 radial cooling kits can be attached to the EXTPX pumps via fixing holes on the base of the product using 5 x M8 screws (supplied). To ensure that the radial cooling kit works most effectively it is recommended that the fan should be placed directly opposite the booster port position. This ensures adequate cooling of the EXDC controller.

3.3.2.3 EXT555H pumps

To base-mount the air-cooler:

3. Refer to [Figure 20](#). Unscrew the rubber pump mounting feet (4).
4. Fit the mounting bracket of the ACX555 air-cooler (2) to the pump-base (6) in the most suitable orientation.
5. Use two M8 x 25 fixing screws (3) and two of the pump mounting feet (4) to secure the mounting bracket in place.
6. Use two spacers (5) and refit the other two pump mounting feet.

To flange-mount the air-cooler, do not refit the pump mounting feet, but use four screws to secure the air-cooler to the pump.

3.3.2.4 Other pumps

3. If necessary, use the two screws supplied to fix the side-mounting bracket onto the air-cooler: refer to the appropriate [Figure 6, 8, 11, 18 or 20](#).
4. Fix the assembled air-cooler and mounting bracket onto the pump-base; use the screws and washers (if applicable) supplied.

3.3.3 Axial mounting



WARNING

Before you install the accessory, ensure that you switch off the pump and isolate the controller as described below.

Note: Axial mounting is only available on EXT250M or EXTPX pumps.

1. Switch off the pump, isolate the pump controller from the electrical supply, and wait until the pump has stopped rotating.
2. Continue at [Step 3](#) in EXT250M pump, EXTPX (axial) or EXTPX (combined radial and axial) section as appropriate.

3.3.3.1 EXT 250M pumps

3. Refer to [Figure 9](#). Use two M5 x 5 screws to fix the right-angle bracket onto the pump-base. Choose the two holes in the pump-base which are most convenient for your installation.
4. Use the two M5 x 5 screws supplied to fit the fan onto the bracket on the pump-base.

3.3.3.2 EXTPX pumps

Refer to [Figure 14 and 15](#).

3. Unscrew the rubber pump mounting feet.
4. Pass the 4 x M4 screws (supplied) through the fan blades to attach the fan to the pump. To access all the fixing holes the fan blades may need to be rotated carefully by hand.
5. With the fan securely fixed to the pump body the protective guard supplied with the product must be attached next. This will ensure safe operation of the cooling assembly. With the protective guard attached the fan can then be connected to the power supply.

3.3.4 Combined radial and axial mounting

Refer to [Figure 16](#).

Maximum pump cooling can be obtained with the simultaneous use of radial and axial cooling fans. The fan arrangements can be coupled together as shown in [Figure 16](#).

3. Unscrew the rubber pump mounting feet.
4. To attach both air-cooling accessories to the pump, firstly combine the two fan arrangements using the 3 x M4 x 10 joining fixings (supplied with the axial fan arrangement).
5. The combined assembly can then be attached to the product via the 4 x M5 axial fan mounting holes. To access all the fixing holes the fans blades on the axial air cooler may need to be rotated carefully by hand.
6. With the fan securely fixed to the pump body the axial cooler protective screen must be attached next. This will ensure safe operation of the cooling assembly. With the protective screen attached the fans can then be connected to the power supply.

3.3.5 Electrical connection

CAUTION

Ensure that the electrical supply is correct. If it is not, you can damage the ACX air-cooler.

CAUTION

Ensure that the power supply to the cooling accessory can be isolated in a fault condition if required.

The ACX air-cooler requires a 24 V d.c. electrical supply. You can connect the ACX air-cooler to an EXC Controller, a TIC or an EXT DX podule, or you can use your own electrical supply.

Note: For combined use of both axial and radial ACX400 air-coolers, a TIC can be used to supply power to one ACX. A separate 24 V power supply is required.

Use the following procedure to make the electrical connections.

1. Shorten the cable to the required length and reconnect the ring terminal.
2. Connect the cable cores to an EXC Controller (refer to the EXC Controller instruction manual), to a TIC (refer to the TIC instruction manual), to a podule connector plug (refer to [Figure 21](#)), or to your own electrical supply.
3. Connect the cable screen to a suitable earth (ground) connection. For EXTPX, an uninsulated braid may be used. Use the M5 x 10 screw and shake-proof washer supplied (attached to fan cowling) to secure the earth conductor to the air-cooler.
4. Switch on the ACX air-cooler (refer to the EXT DX, EXC or TIC instruction manual, or switch on your own electrical supply) and ensure that the fan in the ACX air-cooler rotates in the correct direction (that is, that cooling-air is blown towards the EXT pump). If the direction of rotation is incorrect, check and correct the electrical connections.

3.4 Operation



WARNING

There is no guard on the outlet of the fan in the ACX air-cooler. Therefore, you must not operate the air-cooler unless it is installed on the pump.



WARNING

The protective guard for the inlet of the ACX400 axial air-cooler or ACX400 axial-radial combination must be attached before connection to the electrical supply.

Operation of the ACX air-cooler depends on how you have connected it:

- If you have connected the ACX air-cooler to an EXC Controller, use the EXC Controller to operate the ACX air-cooler: refer to the EXC Controller instruction manual.
- If you have connected the ACX air-cooler to the podule of an EXT DX pump, reconfigure the podule to operate the fan: refer to the EXT DX pump instruction manual.
- If you have connected the ACX air-cooler to a TIC: refer to the TIC instruction manual for operating instructions.
- If you have connected the ACX air-cooler to your own electrical supply, switch on the electrical supply to operate the ACX air-cooler.

When you operate the ACX air-cooler, do not obstruct the fan-inlet; ensure that there is an adequate supply of cooling-air. During operation, if the temperature of any surface of the pump is higher than 60 °C the pump is too hot and you must increase the cooling.

Figure 21 - EXT DX podule connector plug

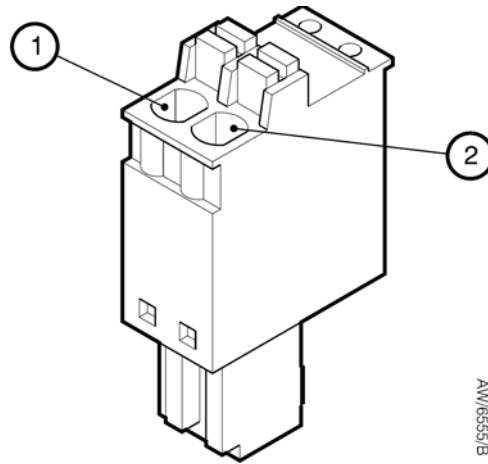

1. -ve (negative) connection
2. +ve (positive) connection

4 TAV vent-valve

4.1 Description

To maintain cleanliness of your vacuum system, we recommend that you vent the pump or vacuum system whenever you switch the pump off.

The TAV vent-valves are 24 V d.c., electrical-solenoid operated valves which you can use to vent your vacuum system with atmospheric air or dry nitrogen when you switch the EXT pump off.

The TAV vent-valve is normally open when the solenoid is de-energised; this is the configuration that you need to use an EXC Controller, a TIC or an EXT DX podule to control the vent-valve.

Refer to [Figure 23](#). The TAV vent-valve is supplied with a sintered bronze inlet-filter (1), a riffled hose connector (7) and 3 metres of cable.

You can connect your dry nitrogen supply to the hose connector.

An NW10 adaptor (3) is also supplied to convert the 1/8 inch BSP outlet connector ([Figure 22](#), item 2) of the TAV vent-valve for direct connection to your vacuum system.

The TAV vent-valve can be powered and controlled from an EXC Controller, a TIC, an EXT DX podule, or from any suitable electrical supply.

4.2 Technical data

Table 3 - TAV vent-valve technical data

| | | |
|-----------------------------------|--|--|
| Configuration | Normally open | |
| Pollution degree | EN61010 Part 1, Category 2 | |
| Equipment type | Fixed equipment for indoor use only | |
| Nominal electrical supply voltage | 24 V d.c. | |
| Electrical supply voltage range | 15 to 24 V d.c. | |
| Pull-in voltage | 14 V d.c. | |
| Drop-out voltage | 10 V d.c. | |
| Power consumption | 1.8 W | |
| Cable type and length | 2-core screened, unterminated, 3 m long | |
| Cable cores | Red (positive), black (negative) | |
| Valve electrical connector type | 2 pole and earth (ground), miniature DIN | |
| Valve inlet-connection | M5 female | |
| Valve outlet-connection | 1/8 inch BSP | |

Table 3 - TAV vent-valve technical data (continued)

| | TAV5 | TAV6 |
|---------------------------------|--|--|
| Maximum inlet pressure | 1 bar gauge, 2×10^5 Pa | 1 bar gauge, 2×10^5 Pa |
| Orifice diameter | 0.5 mm | 1.0 mm |
| Helium leak rate (valve closed) | $< 1 \times 10^{-8}$ mbar l s ⁻¹ $< 1 \times 10^{-6}$ Pa l s ⁻¹ | $< 1 \times 10^{-6}$ mbar l s ⁻¹ $< 1 \times 10^{-4}$ Pa l s ⁻¹ |
| Valve inlet-filter | Sintered bronze | Sintered bronze |
| Hose connector | Riffled nozzle for 4 mm bore tube | Riffled nozzle for 4 mm bore tube |
| Dimensions | See Figure 22 | See Figure 22 |
| Mass | 0.08 kg | 0.08 kg |
| Item Numbers | B580-66-010 | B580-66-020 |

Figure 22 - TAV vent-valve dimensions (mm)

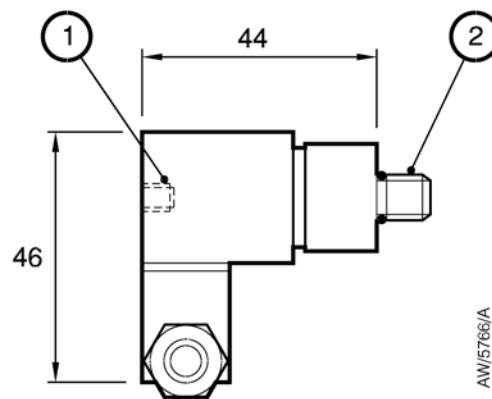

1. M5 female thread
2. 1/8 inch BSP male thread

4.3 Installation

4.3.1 Unpack and inspect

Remove all packing materials and protective covers and check the TAV vent-valve.

If the TAV vent-valve is damaged, notify your supplier and the carrier in writing within three days; state the Item Number of the TAV vent-valve together with your order number and your supplier's invoice number. Retain all packing materials for inspection. Do not use the TAV vent-valve if it is damaged.

4.3.2 Fit the TAV vent-valve to the pump



WARNING

Before you install the accessory, ensure that you switch off the pump and isolate the controller/podule as described below.

1. Switch off the pump, isolate the pump controller from the electrical supply (on an EXT DX pump, isolate the podule from the electrical supply), and wait until the pump has stopped rotating.
2. If your EXT pump has a manual vent-valve, unscrew and remove it, then continue at [Step 4](#).
3. Refer to [Figure 23](#). If your EXT pump does not have a manual vent-valve, fit the vent-valve adaptor (3) to a suitable NW10 flange on your pump or vacuum system.
4. Check that the TAV vent-valve O-ring (4) is fitted and screw the TAV vent-valve into the vent-valve adaptor or into the 1/8 inch BSP hole vacated by the manual vent-valve.
5. Connect your dry nitrogen or other inert gas supply pipeline to the M5 inlet (2) or use the riffled hose connector (7) supplied.
6. If you vent the pump with air, fit the sintered bronze inlet-filter (1) to protect your system against the entry of dust.

4.3.3 Electrical connection

CAUTION

Ensure that the electrical supply is correct. If it is not, you can damage the TAV vent-valve.

The TAV vent-valve requires a 24 V d.c. electrical supply. You can connect the TAV vent-valve to an EXC Controller, a TIC, an EXT DX podule, or your own electrical supply. Use the following procedure to make the electrical connections.

1. Shorten the cable to the required length.
2. Connect the cable cores to an EXC Controller (refer to the EXC Controller instruction manual), to a TIC (refer to the TIC instruction manual), to an EXT DX podule connector plug (refer to [Figure 21](#)), or to your own electrical supply.
3. Connect the cable screen to a suitable earth (ground) connection.

4.4 Operation

CAUTION

If you manually vent the pump when it is at full rotational speed and the rate of pressure rise is too high, the pump life may be reduced. When using the manual vent valve supplied, we recommend that you either limit the vent or only open the vent-valve after the EXT406PX pump speed has fallen to 50% of full rotational speed. Do not vent from the backing line as this may lead to contamination. If you vent into your vacuum system and use an oil sealed rotary backing pump, select a point upstream of the EXTPX pump, to prevent oil back-streaming from the backing line.

Operation of the TAV vent-valve depends on how you have connected it:

- If you have connected the TAV vent-valve to an EXC Controller, use the EXC Controller to operate the vent-valve: refer to the EXC Controller instruction manual.

- If you have connected the TAV vent-valve to the podule of an EXT DX pump: refer to the EXT DX pump instruction manual.
- If you have connected the TAV vent-valve to a TIC: refer to the TIC instruction manual for operating instructions.
- If you have connected the TAV vent-valve to your own electrical supply, switch on the electrical supply to operate the vent-valve.

Figure 23 - TAV vent-valve connections

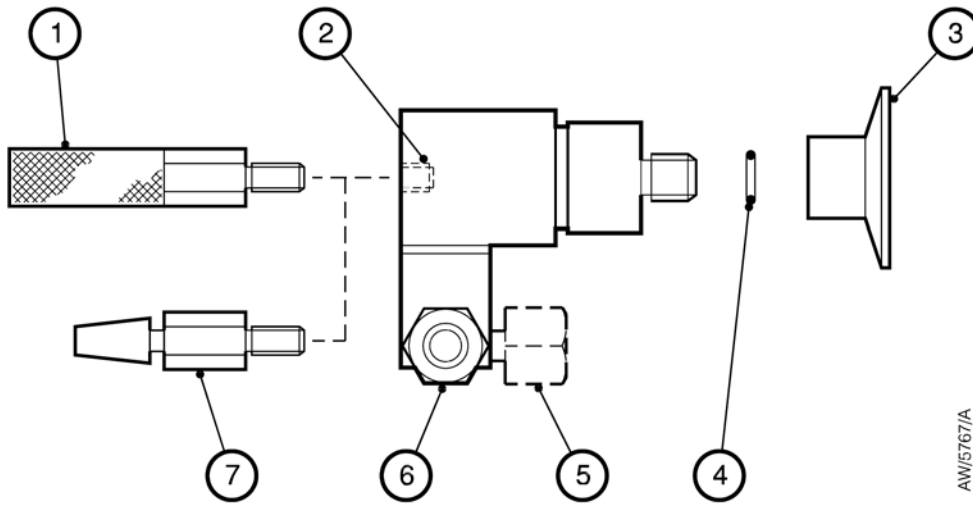

- 1. Air filter
- 2. Inlet-port
- 3. Vent-valve adaptor
- 4. O-ring
- 5. Alternative electrical supply connector position
- 6. Electrical supply connector
- 7. Hose connector

AW/5767/A

5 Vibration isolator

5.1 Description

A Vibration Isolator can be fitted to the inlet-flange of your EXT pump to reduce the transmission of the small amount of vibration generated by the pump to your vacuum system.

The Vibration Isolator has two flanges separated by a flexible stainless steel bellows and an outer rubber anti-vibration collar.

The Vibration Isolator is designed for use with a vertically mounted pump only.

5.2 Technical data

Table 4 - Vibration isolators technical data

| | | | |
|---|--------------------|------------|------------|
| Minimum attenuation of vibration amplitude* | >1000:1 | | |
| Vibration Isolators with ISO flanges | | | |
| Flange size | DN63ISO-K | DN100ISO-K | DN160ISO-K |
| Inside diameter (mm) | 35 | 75 | 95 |
| Overall length (mm) | 82 | 82 | 95 |
| Mass (kg) | 1.4 | 1.7 | 3.2 |
| Maximum tensile load (kg) | 15 | 20 | 25 |
| Minimum number of claw clamps | 4 | 4 | 4 |
| Vibration Isolators with CF flanges | | | |
| Flange size | DN63CF | DN100CF | DN160CF |
| Inside diameter (mm) | 35 | 75 | 95 |
| Overall length (mm) | 98 | 98 | 107 |
| Mass (kg) | 3.3 | 4.5 | 6.0 |
| Maximum tensile load (kg) | 15 | 20 | 25 |
| Item Number | | | |
| Flange size | Item Number | | |
| DN63CF | B581-01-000 | | |
| DN63ISO-K | B581-15-000 | | |
| DN100ISO-K | B581-20-000 | | |
| DN100CF | B581-05-000 | | |
| DN160ISO-K | B581-25-000 | | |
| DN160CF | B581-10-000 | | |

* Vibration attenuation depends on frequency of interest and mass of vacuum system. Stated value is typical for vibration at pump operational frequency, and for system with mass of ~200 kg.

5.3 Installation

5.3.1 Unpack and inspect

Remove all packing materials and protective covers and check the Vibration Isolator.

If the Vibration Isolator is damaged, notify your supplier and the carrier in writing within three days; state the Item Number of the Vibration Isolator together with your order number and your supplier's invoice number. Retain all packing materials for inspection. Do not use the Vibration Isolator if it is damaged.

5.3.2 Fit the vibration isolator



WARNING

Before you install the accessory, ensure that you switch off the pump and isolate the controller/podule as described below.

Fit the Vibration Isolator as described below. Refer to the instruction manual supplied with your EXT pump to determine the minimum number of bolts or clamps that you will need to fit the Vibration Isolator to the pump inlet-flange. You must use the same number of bolts or clamps to fit the upper flange of the Vibration Isolator to your vacuum system.

1. Switch off the pump, isolate the pump controller from the electrical supply (on an EXT DX pump, isolate the podule from the electrical supply), and wait until the pump has stopped rotating.
2. Fit the Vibration Isolator between the inlet-flange of your EXT pump and your vacuum system.
3. Fit a flexible bellows between the EXT pump backing-port and the backing-pump to prevent the transmission of vibration or strain between the two pumps.
4. Fit a suitable restraint so that the pump cannot rotate on its axis in the unlikely event of total seizure of the pump rotor. The figure below shows a suitable arrangement, using bolts and a support frame with clearance holes.



WARNING

The vibration isolator is unable to withstand the large forces generated in the event of total rotor failure. An additional restraining means must be fitted.

Figure 24 - Vibration isolator installation

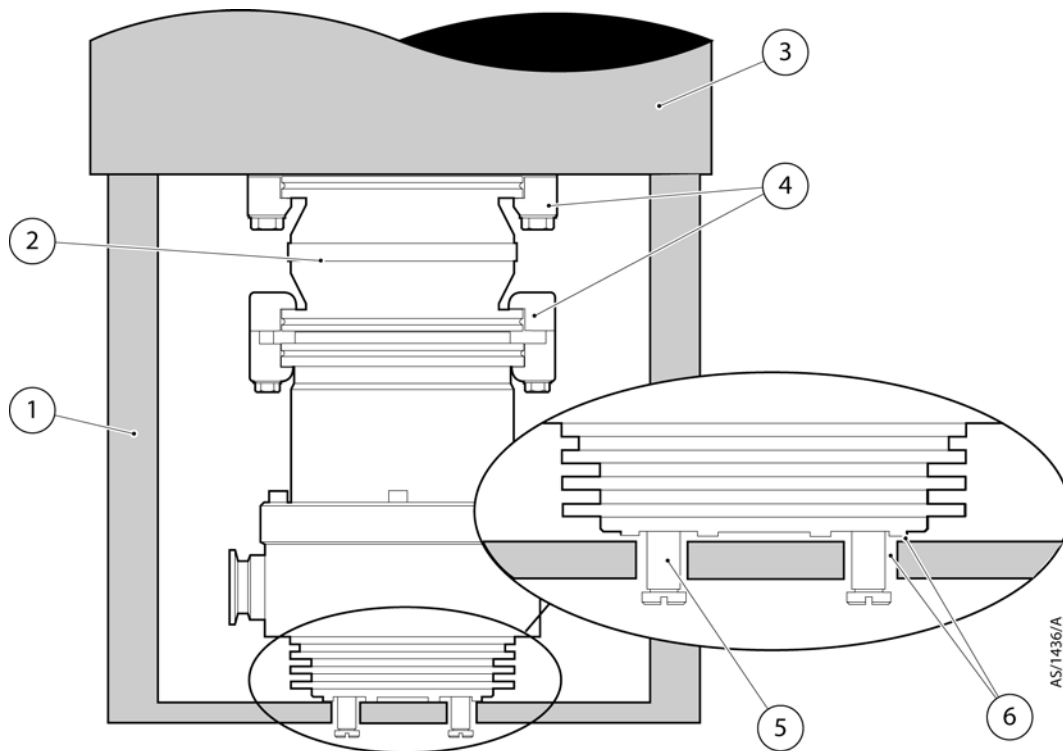

1. Rigid frame secured to vacuum system
2. Vibration isolator
3. Vacuum system
4. Claw clamps
5. Shoulder screws
6. Clearance

AS/1436/A

6 Inlet screens

6.1 Description

Inlet-screens are factory-fitted to all new EXT pumps. If you have an EXT pump without an inlet-screen, we recommend that you fit an inlet-screen for additional safety. The only exception to this is the main ports in the END faces of split flow pumps. Plastic covers must be retained on these variants until ready to install to minimise the risk of injury from impeller blades.

The inlet-screen prevents the entry of debris into the pump and also prevents people from coming into contact with the blades if the pump is switched on when it is disconnected from your vacuum system.

6.2 Technical data

Note: Refer to the pump instruction manual for details of performance reductions when an inlet-screen is fitted.

Table 5 - Inlet-screens technical data

| Mesh/ hole size | Screen type | Pump models | Pump inlet-flange sizes | Item Number |
|------------------|-------------|----------------------------------|-------------------------|-------------|
| 1 mm hexagonal | ISX | EXT70/70H | DN63 ISO-K, DN63CF | B580-51-005 |
| 1 mm hexagonal | ISX | EXT70/250/250H/ 250M/255H/ 255DX | DN100 ISO-K, DN100CF | B580-51-001 |
| 1 mm hexagonal | ISX | EXT301/501 | DN160 ISO-K, DN160CF | B580-51-002 |
| 1.8 mm hexagonal | ISDX | EXT75DX | DN63 ISO-K, DN63CF | B722-40-860 |
| 2.5 mm hexagonal | ISHX | EXT555H | DN160 ISO-K, DN160CF | B777-00-058 |
| 1 mm hexagonal | ISHX | EXT555H | DN160 ISO-K, DN160CF | B777-00-059 |
| 2.5 mm hexagonal | ISX | EXT406PX | DN100 ISO-K, DN100CF | B756-40-813 |
| 2.5 mm hexagonal | ISX | EXT406PX | DN160 ISO-K, DN160CF | B760-21-806 |
| 2.5 mm hexagonal | ISDX | EXTPX | Split flow chamber | B760-61-812 |
| 2.5 mm hexagonal | ISDX | EXTPX | Split flow chamber | B760-53-812 |

6.3 Installation

6.3.1 Unpack and inspect

Remove all packing materials and protective covers and check the inlet-screen.

If the inlet-screen is damaged, notify your supplier and the carrier in writing within three days; state the Item Number of the inlet-screen together with your order number and your supplier's invoice number. Retain all packing materials for inspection. Do not use the inlet-screen if it is damaged.

6.3.2 Fit or remove the inlet-screen



WARNING

Before you install the accessory, ensure that you switch off the pump and isolate the controller/podule as described below.



WARNING

If you remove the inlet-screen, there will be a risk of injury from exposed sharp edges in the pump.

CAUTION

Do not remove the inlet-screen unless you can be sure that debris cannot fall into the pump. Debris which falls into the pump can seriously damage it.

Note: If you have an EXT pump with an NW40 or NW50 inlet-flange, inlet-screen replacement must be carried out by Edwards; you cannot replace the inlet-screen yourself.

1. Switch off the pump, isolate the pump controller from the electrical supply (on an EXT DX pump, isolate the podule from the electrical supply), and wait until the pump has stopped rotating.
2. Use the following appropriate procedure according to the type of inlet-screen.

6.3.2.1 ISX inlet-screens

To remove the ISX inlet-screen:

- Use a wire hook or a small screwdriver to carefully extract the inlet-screen from the pump inlet-flange.

To fit the ISX inlet-screen:

- Refer to [Figure 25](#). Lower the inlet-screen (with the Edwards logo (if present) at the top) into the pump-inlet until the dimples on the rim of the screen engage in the groove in the pump-inlet bore, as shown in [Figure 25](#). If necessary, bend the rim of the screen outwards to ensure a good fit.

6.3.2.2 ISDX inlet-screens

To remove the ISDX inlet-screen:

- Use a wire hook or a small screwdriver to carefully lever the inlet-screen from the pump inlet-flange.

To fit the ISDX inlet-screen:

- Refer to [Figure 26](#). Hold the inlet-screen (with the tags pointing upwards) centrally over the pump inlet-flange.
- With your fingers spread evenly around the edge of the inlet-screen, push the inlet-screen firmly into the bore of the inlet-flange.
- Ensure that all of the tags on the rim of the inlet-screen are correctly positioned under the rim of the inlet-flange. If necessary, use a suitable tool to press the tags into position.

6.3.2.3 ISHX inlet-screens

CAUTION

Do not remove the three screws (Figure 27, item 1). If you do, the pump settings may change, and the pump may not operate correctly, or have a shortened operating life.

To remove the ISHX inlet-screen:

- Refer to Figure 27. Undo and remove the three screws (3) which secure the inlet-screen (2), then remove the inlet-screen. Do not remove or loosen the other three screws (1).

To fit the ISHX inlet-screen:

- Refer to Figure 27. Fit the inlet-screen (2) in position and secure with the three securing screws (3). Do not remove or loosen the other three screws (1).

Figure 25 - ISX inlet-screen

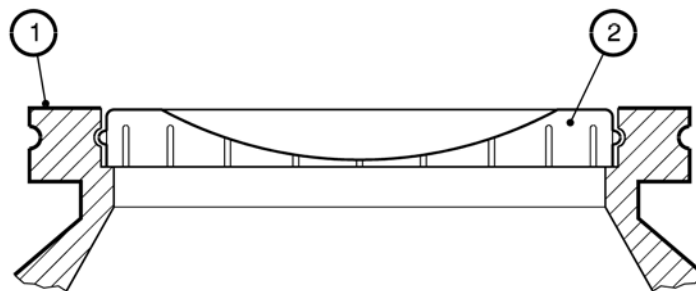

- EXT inlet-flange
- Inlet-screen

Figure 26 - ISDX inlet-screen

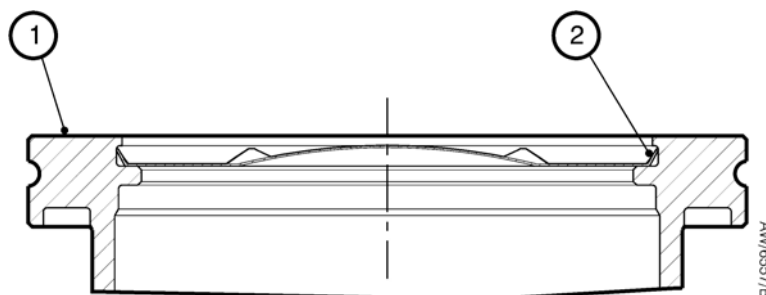

- EXT inlet-flange
- Inlet-screen

Figure 27 - ISHX inlet-screen

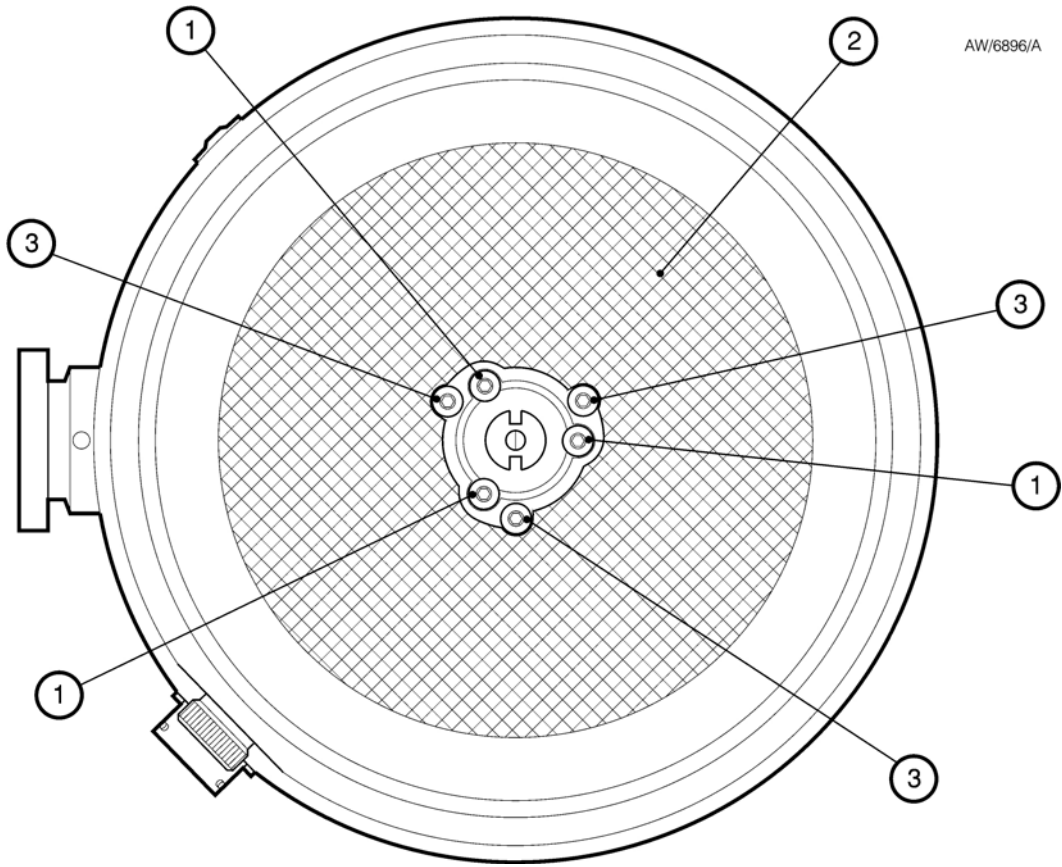

- 1. Screws: do not remove or loosen
- 2. ISHX inlet-screen mesh
- 3. Screws: remove to remove/fit inlet-screen

7 PRX10 purge-restrictor

7.1 Description

The PRX10 purge-restrictor (shown in [Figure 28](#)) sets the purge gas flow rate.

The following EXT pumps have a purge-port facility to allow you to purge the motor and bearing cavity with dry nitrogen or other inert gas:

- EXT75DX, EXT75iDX.
- EXT250, EXT250H, EXT250Hi, EXT250M, EXT255DX, EXT255iDX, EXT255H and EXT255Hi.
- EXT 351 and EXT501 (all models).
- EXT555H, EXT555HF, EXT555Hi, EXT555H_E and EXT556.
- EXT406PX and EXTPX split flow

Note that you will need a vent-port adaptor (see [Section 9](#)) to fit the PRX10 purge-restrictor.

7.2 Technical data

Table 6 - PRX10 purge-restrictor technical data

| | |
|-----------------------------|---|
| Nominal nitrogen flow rate* | 255 sccm, 0.42 mbar l s ⁻¹ , 42 Pa l s ⁻¹ |
| Flange size | NW10 |
| Item Number | B580-65-001 |

* At a supply pressure of 0 bar gauge (1×10^5 Pa)

7.3 Installation

7.3.1 Unpack and inspect

Remove all packing materials and protective covers and check the PRX10 purge-restrictor.

If the PRX10 purge-restrictor is damaged, notify your supplier and the carrier in writing within three days; state the Item Number of the PRX10 purge-restrictor together with your order number and your supplier's invoice number. Retain all packing materials for inspection. Do not use the PRX10 purge-restrictor if it is damaged.

7.3.2 Fit the purge-restrictor



WARNING

Before you install the accessory, ensure that you switch off the pump and isolate the controller/podule as described below.

CAUTION

Do not exert any sideways force on the purge-restrictor when you clamp it into place. If you do, you can damage the seal between the O-ring (Figure 28, item 2) and the body of the purge-restrictor. If the seal is damaged, gas may leak through the seal and you will not be able to properly control gas flow into the pump.

Note: If you will use a purge gas other than nitrogen, you must calibrate the purge-restrictor (refer to Section 7.4.2) before you connect your purge gas supply.

1. Switch off the pump, isolate the pump controller from the electrical supply (on an EXT DX pump, isolate the podule from the electrical supply), and wait until the pump has stopped rotating.
2. Remove the blank and clamp from the purge-port on the pump.
3. Attach your purge gas supply pipeline (which must be terminated with an NW10 flange) to the purge-port with the PRX10 purge-restrictor in place of the normal NW10 centring-ring.
4. Carefully secure the connection with the NW10 clamp.

7.4 Operation

7.4.1 General

The PRX10 purge-restrictor, as supplied, is adjusted to restrict the flow rate of dry nitrogen, at a supply pressure of 0 bar gauge (1×10^5 Pa), to 25 sccm ($0.42 \text{ mbar l s}^{-1}$, 42 Pa l s^{-1}). You can increase the supply pressure to increase the flow rate; see Table 7.

For most applications, you can use a nitrogen flow rate of 25 sccm ($0.42 \text{ mbar l s}^{-1}$, 42 Pa l s^{-1}) to 30 sccm ($0.5 \text{ mbar l s}^{-1}$, 50 Pa l s^{-1}). To do this, your nitrogen supply pressure must be 0.1 to 0.2 bar gauge (1.1×10^5 to 1.2×10^5 Pa). Do not exceed the maximum purge gas supply pressure given in the instruction manual supplied with your pump.

7.4.2 Calibration of the PRX10 for different purge gases

The purge gas flow rate at a particular supply pressure will change if you use a different purge gas.

If you want to use a different purge gas, use the procedure below to adjust the flow rate.

1. Fit the PRX10 purge-restrictor to the pump as described in Section 7.3.2. Fit a calibrated mass flowmeter between your purge gas supply and the PRX10 purge-restrictor.
2. Switch on the backing-pump to evacuate the EXT pump, then turn on your purge gas supply.
3. Monitor the indicated purge gas flow rate while you adjust the purge gas supply pressure. If you can achieve the required flow rate, you do not need to adjust the purge-restrictor; in this case, continue at Step 5 below.
4. Refer to Figure 28. If you cannot achieve the required flow rate, undo the locknut (3) on the purge-restrictor and use a small screwdriver to turn the adjustment screw (4) clockwise to decrease the flow rate or anticlockwise to increase the flow rate. Tighten the locknut.
5. Turn off your purge gas supply, remove the mass flow meter and connect your purge gas supply to the purge-restrictor.

Table 7 - Nitrogen flow rate through the PRX10 purge-restrictor

| Nitrogen supply pressure | | | Nitrogen flow rate | | |
|--------------------------|--------------|-----------------------|--------------------|------------------------|----------------------|
| bar gauge | bar absolute | Pa | sccm | mbar l s ⁻¹ | Pa l s ⁻¹ |
| 0.0 | 1.0 | 1.0 x 10 ⁵ | 25 | 0.42 | 42 |
| 0.5 | 1.5 | 1.5 x 10 ⁵ | 38 | 0.63 | 63 |
| 1.0 | 2.0 | 2.0 x 10 ⁵ | 50 | 0.83 | 83 |
| 1.5 | 2.5 | 2.5 x 10 ⁵ | 63 | 1 | 100 |
| 2.0 | 3.0 | 3.0 x 10 ⁵ | 75 | 1.25 | 125 |
| 2.3 | 3.5 | 3.5 x 10 ⁵ | 88 | 1.5 | 150 |
| 3.0 | 4.0 | 4.0 x 10 ⁵ | 100 | 1.7 | 170 |

Figure 28 - PRX10 purge-restrictor

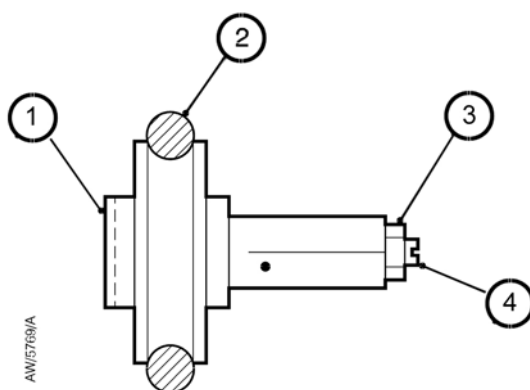

1. Filtered purge gas inlet to PRX10 purge-restrictor
2. O-ring
3. Locknut
4. Adjustment screw

8 Pump-to-controller cable

Note: Pump-to-controller cables are not applicable to EXT DX pumps. If you need extension cables for EXT DX pumps, refer to the Edwards catalogue, or contact your supplier or Edwards.

8.1 Description

Complete cables are available for 80 V pumps in 1, 3 and 5 metre lengths to suit your application.

The EXT250M pump is supplied with an EXC300M Controller and a 1, 3 or 5 metre cable.

8.2 Technical data

Table 8 - Pump-to-controller cables technical data

| | | |
|-------------------------------|------------------------------|-------------|
| Pump end connector type | MIL-C-26482 (US) 14-19P | |
| Controller end connector type | QM multipole, 19 pins | |
| Cable | Screened, multiway | |
| Item Numbers | | |
| Length | Pump models | Item Number |
| 1 m | All EXT pumps except EXT250M | D396-18-010 |
| 3 m | All EXT pumps except EXT250M | D396-18-030 |
| 5 m | All EXT pumps except EXT250M | D396-18-050 |
| 1 m | EXT250M | D396-19-010 |
| 3 m | EXT250M | D396-19-030 |
| 5 m | EXT250M | D396-19-050 |

8.3 Installation

8.3.1 Unpack and inspect

Remove all packing materials and protective covers and check the cable.

If the cable is damaged, notify your supplier and the carrier in writing within three days; state the Item Number of the cable together with your order number and your supplier's invoice number. Retain all packing materials for inspection. Do not use the cable if it is damaged.

8.3.2 Connect the pump-to-controller cable



WARNING

Before you install the accessory, ensure that you switch off the pump and isolate the controller as described below.

1. If the pump is operating: switch off the pump, isolate the pump controller from the electrical supply, and wait until the pump has stopped rotating.
2. If fitted, remove the existing pump-to-controller cable.
3. Fit the new pump-to-controller cable: refer to the controller instruction manual.

9 Vent-port adaptor

9.1 Description

The 1/8 inch BSP(P) male to NW10 vent-port adaptor can be used to convert the 1/8 inch BSP(P) female vent port on all EXT pumps to an NW10 flange. An alternative vent valve to the TAV 5/6 or a vent pipeline may then be fitted to this flange. See [Figure 29](#).

Figure 29 - Vent-port adaptor

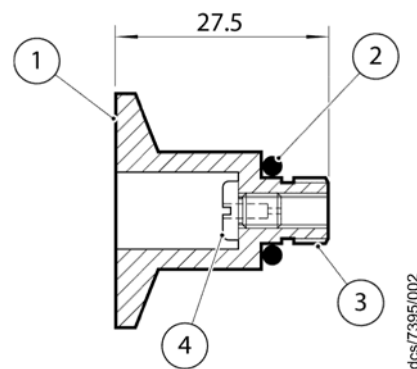

1. NW10 flange
2. O-ring
3. 1/8 inch BSP male thread
4. Removable flow-restrictor

The vent-port adaptor is supplied with a removable flow restrictor and an O-ring to seal the adaptor to the pump. It is best suited to the following pump types:

- EXT75DX, EXT75iDX
- EXT255DX, EXT255iDX
- EXT255H, EXT255Hi
- EXT556H, EXT555H and EXT555H_E
- EXT406PX and EXTPX split flow

Also available is an extended vent-port adaptor which is intended for use with the split-flow turbo pumps where the backing port is too close to the vent-port to allow the standard vent-port adaptor to be used. The extended vent-port adaptor is supplied with an O-ring to seal to the pump, NW10 centering ring and NW10/16 clamping ring. Refer to [Figure 30](#).

Figure 30 - Extended vent-port adaptor

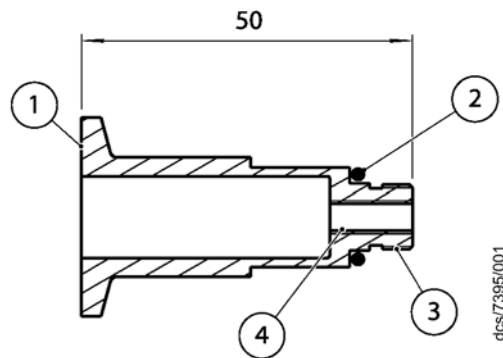

1. NW10 flange
2. O-ring
3. 1/8 inch BSP male thread
4. M5 Internal thread

CAUTION

The extended vent-port adaptor is not supplied with a removable flow restrictor. Venting a turbo pump from atmosphere, through the extended vent-port adaptor, would cause damage to the turbo pump. To vent a turbo pump when using the extended vent-port adaptor, you must either control the flow-rate to the adaptor or incorporate a 0.8 mm orifice in the pipeline used to connect to the extended vent-port adaptor.

The extended vent-port adaptor is best suited to the following pump types:

- EXT200/200H
- EXT200/200Hi
- EXT200/200/30H
- EXT400/200/30H
- EXT70/70/200H

9.2 Technical data

Table 9 - Vent-port adaptor technical data

| | |
|-------------------|-------------|
| Internal diameter | 0.8 mm |
| Flange size | NW10 |
| Item number | B580-66-011 |

Table 10 - Extended vent-port adaptor technical data

| | |
|-------------------|-------------|
| Internal diameter | M5 thread |
| Flange size | NW10 |
| Item Number | B580-66-028 |

9.3 Installation

9.3.1 Unpack and inspect

Remove all packing materials and protective covers and check the vent-port adaptor.

If the vent-port adaptor is damaged, notify your supplier and the carrier in writing within three days; state the Item Number of the vent-port adaptor together with your order number and your supplier's invoice number. Retain all packing materials for inspection. Do not use the vent-port adaptor if it is damaged.

9.3.2 Connect the vent-port adaptor



WARNING

Before you install the accessory, ensure that you switch off the pump and isolate the controller/podule as described below.

1. Switch off the pump, isolate the pump controller from the electrical supply (on an EXT DX pump, isolate the podule from the electrical supply), and wait until the pump has stopped rotating.
2. Unscrew and remove the manual vent-valve or the plug in the purge port from the EXT pump.
3. Refer to [Figure 30](#). Check that the vent-port adaptor has an O-ring (2) fitted and screw the adaptor into the 1/8 inch BSP vent-port. Tighten the adaptor so that it seals firmly against the face of the vent-port.
4. Connect your vent pipeline to the NW10 flange (1) of the adaptor with suitable fittings.

10 VRX vent - restrictor

10.1 Description

- Notes:*
1. A VRX vent-restrictor can be fitted in any EXT pump vent-port or purge-port.
 2. EXT250M pumps are supplied with a purge port (sealed with a purge plug), and with VRX10 vent-restrictors fitted in the vent and purge ports.

Fit a VRX vent-restrictor to your EXT pump if you will vent the pump when the pump speed is above 50% of full rotational speed. The vent-restrictor restricts the flow-rate of the vent gas into the EXT pump.

You can fit the VRX vent-restrictor directly to the inlet of a vent-port adaptor, together with a TAV vent-valve (if required). Note that you must fit the vent-restrictor before you fit the TAV vent-valve or vent-port adaptor.

10.2 Technical data

Table 11 - Vent-restrictor technical data

| VRX | Orifice diameter | Item Number |
|-------|------------------|-------------|
| VRX10 | 0.1 mm | B580-66-021 |
| VRX20 | 0.2 mm | B580-66-022 |
| VRX30 | 0.3 mm | B580-66-023 |
| VRX50 | 0.5 mm | B580-66-024 |
| VRX70 | 0.7 mm | B580-66-025 |

10.3 Installation

10.3.1 Unpack and inspect

Remove all packing materials and protective covers and check the vent-restrictor. The VRX identification number (Figure 31, item 5) is located on the restrictor base; for example, if you have a VRX20 vent-restrictor, '20' will be shown on the base of the restrictor.

If the vent-restrictor is damaged, notify your supplier and the carrier in writing within three days; state the Item Number of the vent-restrictor together with your order number and your supplier's invoice number. Retain all packing materials for inspection. Do not use the vent-restrictor if it is damaged.

10.3.2 VRX vent-restrictor selection

Make sure that you have the correct vent-restrictor for your pump and vacuum system. Refer to your EXT pump instruction manual for selection details.

You must not exceed the maximum allowable rate of pressure rise specified in the EXT pump instruction manual.

10.3.3 Fit the vent-restrictor



WARNING

Before you install the accessory, ensure that you switch off the pump and isolate the controller/podule as described below.

Use the following procedure to fit the vent-restrictor to an EXT pump:

1. Switch off the pump, isolate the pump controller from the electrical supply (on an EXT DX pump, isolate the podule from the electrical supply), and wait until the pump has stopped rotating.
2. Remove the vent-valve or plug from the EXT pump, or disconnect the vacuum connections from the purge port as appropriate.
3. Refer to Figure 31. If a vent-restrictor is already fitted, fit a suitable M3 screw into the M3 tapped hole (2) in the restrictor, then pull the screw to remove the old vent-restrictor.
4. Fit a suitable M3 screw to the new restrictor and push the new restrictor fully into the vent-port or purge-port of the EXT pump.
5. Remove the M3 screw and refit the vent-valve or plug, or reconnect the vacuum connections to the purge-port.

Figure 31 - VRX vent-restrictor

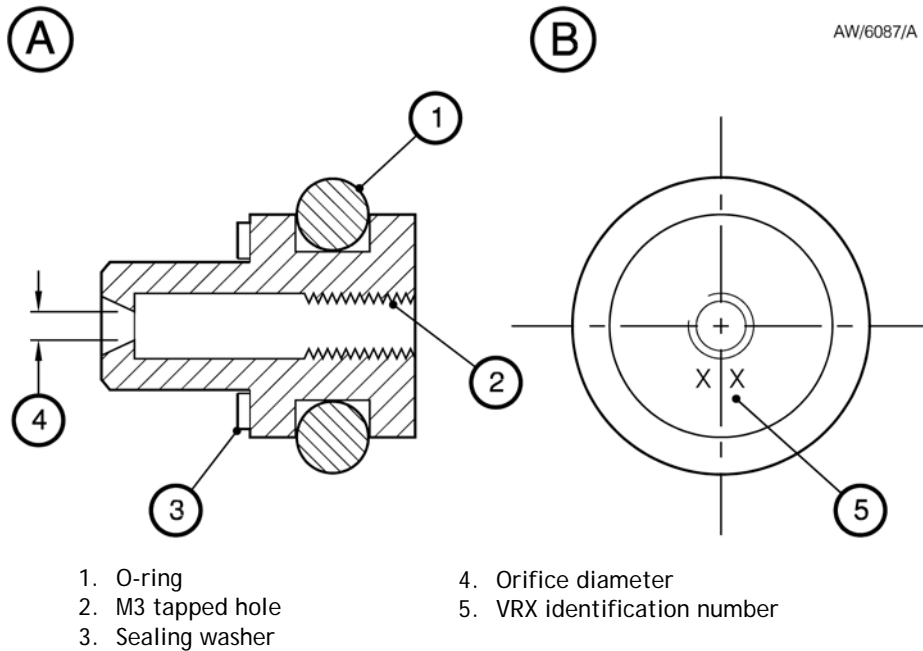

11 WCX water-cooler

11.1 Description

Note: A WCX water-cooler is fitted to some EXT pumps as standard: refer to your pump instruction manual.

A WCX water-cooler can be fitted to all EXT pumps, to provide water-cooling during pump operation.

Refer to the pump instruction manual to determine the operating conditions under which you must use water-cooling.

11.2 Technical data

Table 12 - WCX water-cooler technical data

| | | |
|---------------------------------|---|--------------------|
| Water connections Dimensions | Riffled nozzles, suitable for reinforced flexible hose (approximately 6 mm i.d) see Figure 32 | |
| Item Numbers | | |
| Model | To fit pump models | Item Number |
| WCX250 | EXT200/200H, EXT250M, EXT406PX and EXTPX split flow | B735-01-164 |
| WCX500 | EXT70/70H/70Hi/75DX/75iDX/250/250H/250Hi/255DX/255iDX/255H/351/501 | B736-00-121 |
| WCX555 | EXT555H/555HF/555Hi | B580-67-003 |

11.3 Installation

11.3.1 Unpack and inspect

Remove all packing materials and protective covers and check the WCX water-cooler.

If the water-cooler is damaged, notify your supplier and the carrier in writing within three days; state the Item Number of the water-cooler together with your order number and your supplier's invoice number. Retain all packing materials for inspection. Do not use the water-cooler if it is damaged.

Figure 32 - WCX555 water-cooler dimensions (mm)

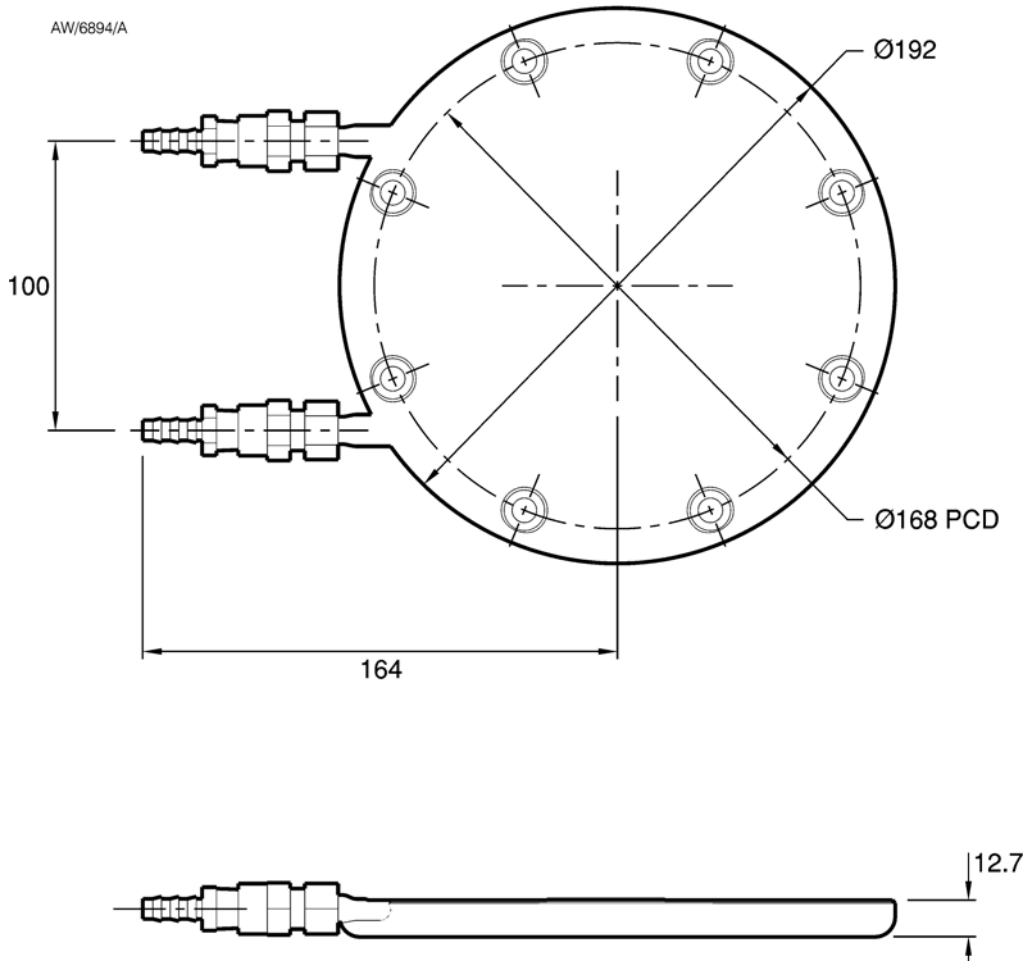
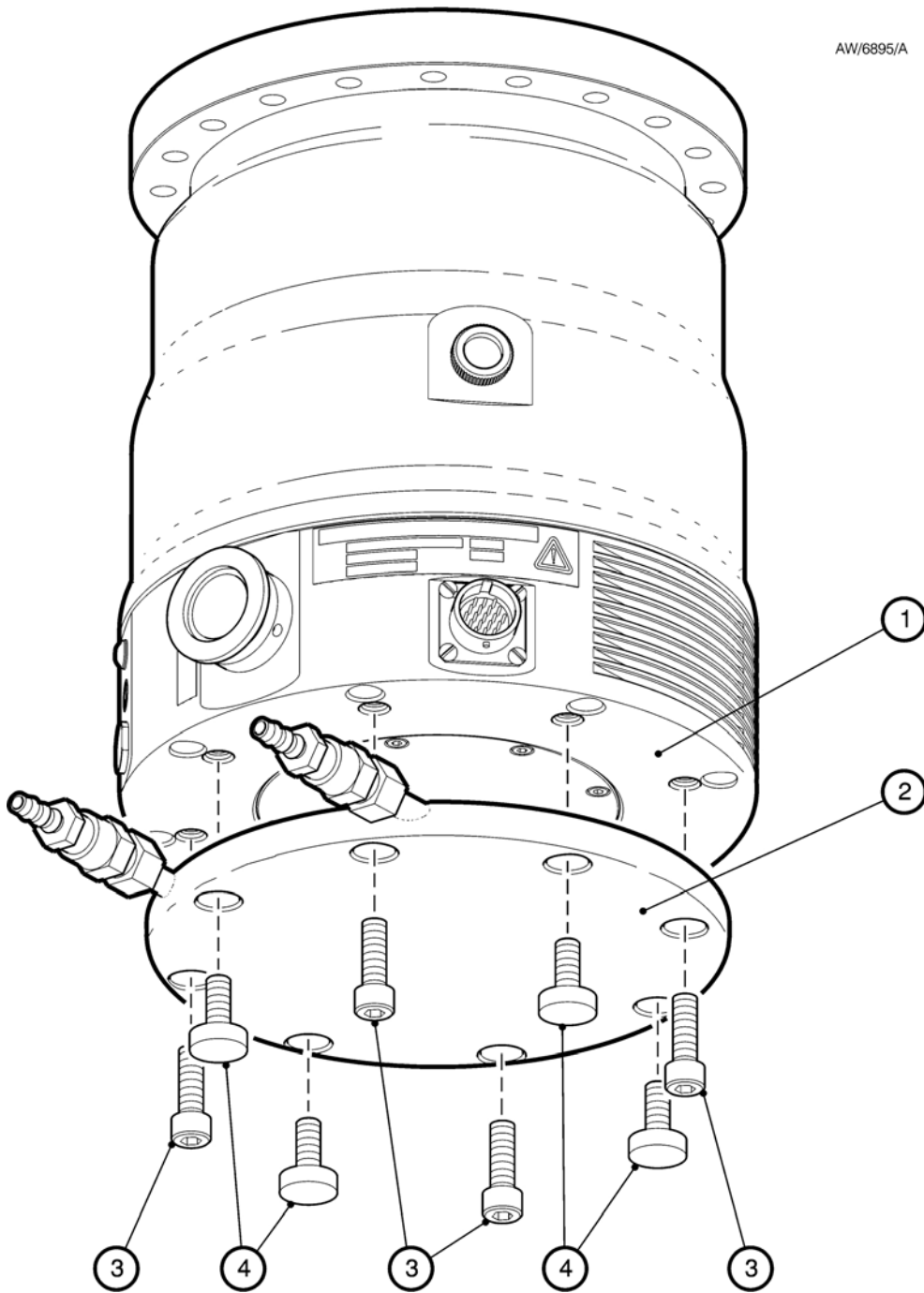

Figure 33 - WCX555 water-cooler installation



AW/6895/A

1. Pump base
2. WCX555 water-cooler
3. Screws: M8 x 25 (4 off)
4. Pump mounting feet (4 off, supplied with the pump)

11.3.2 Fit the water-cooler to the pump



WARNING

Before you install the accessory, ensure that you switch off the pump and isolate the controller/podule as described below.

1. Switch off the pump, isolate the pump controller from the electrical supply (on an EXT DX pump, isolate the podule from the electrical supply), and wait until the pump has stopped rotating.
2. Continue at the appropriate procedure below, according to your model of water-cooler.

11.3.2.1 WCX250 and WCX500 water-coolers

1. If necessary, remove the old water-cooler from the pump, and retain the fixing screws.
2. Use the screws removed in [Step 1](#), or the two or three screws supplied (depending on the pump model) to secure the new water-cooler to the pump.
3. Remove the protective covers from the ends of the riffled nozzles.
4. Fit and secure your cooling-water hoses to the riffled nozzles. Ensure that you route the hoses away from any electrical cables, wires and connections.
5. Briefly turn on the cooling-water supply and check for water leaks. Seal any leaks found.

11.3.2.2 WCX555 water-cooler

CAUTION

When you fit the WCX555 accessory, do not apply any thermal compound to either the water-cooler or the EXT pump.

1. Fit the protective cover supplied with the pump to the pump-inlet, then turn the pump upside down.
2. Refer to [Figure 33](#). Unscrew and remove the four pump mounting feet (4).
3. Use the four M8 x 25 cap-head screws (3, supplied with the water-cooler) to secure the cooling plate to the base of the pump.
4. Refit the four pump mounting feet (4).
5. Remove the protective covers from the ends of the riffled nozzles.
6. Fit and secure your cooling-water hoses to the riffled nozzles. Ensure that you route the hoses away from any electrical cables, wires and connections.
7. Briefly turn on the cooling-water supply and check for water leaks. Seal any leaks found.

11.4 Operation

CAUTION

Ensure that the cooling-water flow is correct for the pump operating conditions. Insufficient or excess cooling-water flow can damage the pump.

Refer to your EXT pump instruction manual for:

- The operating conditions under which you must use water-cooling.
- The necessary cooling-water supply flow rates and temperatures.

12 Maintenance

Edwards EXT Accessories require little user maintenance and contain no user serviceable parts. To maintain the accessories in normal use, do the appropriate checks below when you maintain the pump.

- Check that all mechanical fixings are secure.
- Check that any electrical connections are secure.
- Check that any electrical supply cables are undamaged.

13 Storage and disposal

13.1 Storage

Store the accessories in cool dry conditions until required for use. When required, prepare and install the accessories as described in Section 2 to 11.

13.2 Disposal

Dispose of the accessories safely in accordance with all local and national safety and environmental requirements. Take particular care with components that have been contaminated with dangerous process substances.