



nEXT85

INSTRUCTION MANUAL

Publication Number: B8G0-00-880

Issue: C

Original Instructions

Chemtech Scientific provides access to this content as a courtesy.
We do not own the content contained in this document.
All rights and credit go directly to its rightful owners.
www.chemtechsci.com
Call us at: 484-424-9415

Copyright notice

All rights reserved. This material is copyright protected. Do not reproduce, distribute, or transmit any part of this publication in any form or by any means. Do not photocopy, record or otherwise reproduce by electronic or mechanical methods without the prior written permission of the copyright owner.

Trademark credits

Edwards and the Edwards logo are trademarks of Edwards Limited.

Associated publications

P400-40-100 *Vacuum Pump and Vacuum Systems safety manual*

Declaration of Conformity

We, Edwards,
 Innovation Drive,
 Burgess Hill,
 West Sussex,
 RH15 9TW, UK

declare under our sole responsibility, as manufacturer and person within the EU authorised to assemble the technical file, that the product(s)*

B 8G b - ccc - dd

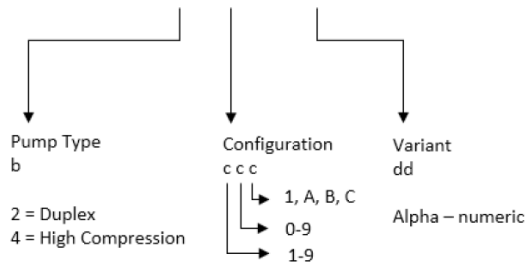

nEXT85

* The material numbers cover a family of pumps where the following component features may vary according to the variant; 'X' denotes combinations of variants of the geometry of pump inlet ports, geometry or position of exhaust port and the material and geometry of the pump casing.

to which this declaration relates is in conformity with the following standard(s) or other normative document(s)

- | | |
|---|---|
| EN1012-2:1996+A1:2009 | Compressors and Vacuum Pumps. Safety Requirements. Vacuum Pumps |
| EN61010-1:2010 | Safety Requirements for Electrical Equipment for Measurement, Control and Laboratory Use. General Requirements |
| EN61326-1:2013
(Class B Emissions,
Industrial Immunity) | Electrical equipment for measurement, control and laboratory Use. EMC requirements. General requirements. |
| CAN/CSA-C22.2
No.61010-1-12 | Safety requirements for electrical equipment for measurement, Control and laboratory use - Part 1: General requirements |
| UL61010-1, 3 rd Edition | Safety requirements for electrical equipment for measurement, Control and laboratory use - Part 1: General requirements |

and fulfils all the relevant provisions of

- | | |
|------------|--|
| 2006/42/EC | Machinery Directive |
| 2014/35/EU | Low Voltage Directive |
| 2014/30/EU | Electromagnetic Compatibility (EMC) Directive |
| 2011/65/EU | Restriction of Certain Hazardous Substances (RoHS) Directive |

Note: This declaration covers all product serial numbers from the date this Declaration was signed onwards.

 Mr Peter Meares
 Senior Technical Support Manager, General Vacuum

26.01.2017, Burgess Hill

 Date and Place

This product has been manufactured under a quality management system certified to ISO 9001:2008

Material Declaration

In accordance with the requirements of the Chinese regulatory requirement on the Management Methods for the Restriction of the Use of Hazardous Substances in Electrical and Electronic Products Order No. 32 (also known as 'China RoHS2') and SJ/T 11364 Marking for the Restricted Use of Hazardous Substances in Electronic and Electrical Products:

Product Labels

Product	Product Label	Meaning
All pumps in the list below		This product contains hazardous substances in at least one of the homogeneous materials used which are above the limit requirement in GB/T 26572 as detailed in the declaration table below. These parts can safely be used for the environmental protection use period as indicated.

Pump Type	Pump Size
RV Pumps	RV3,5,8,12, E Lab, nRvi
EM Small Pumps	E2M0.7, 1.5, E1M18, E2M18, 28, 30, nE2M40i
nEXT Pumps	nEXT 85, 240, 300, 400, Splitflow
nXDS pumps	nXDS 6, 10, 15, 20
EXT pumps	EXT75DX
XDS pumps	XDS35, 46, 100
Diaphragm	XDD 1, D lab
Turbo Pump Carts	T station, nEXPT, nEXT station

材料成分声明

Materials Content Declaration





部件名称 Part name	危险物质					
	铅 Lead (Pb)	汞 Mercury (Hg)	镉 Cadmium (Cd)	六价铬 Hexavalent Chromium (Cr VI)	多溴联苯 Polybrominated biphenyls (PBB)	多溴二苯醚 Polybrominated diphenyl ethers (PBDE)
铸铝 Cast Aluminium	X	O	O	O	O	O
铜管管件 Brass pipe Fittings	X	O	O	O	O	O
铜接头 Brass Connectors	X	O	O	O	O	O

O : 表示该有害物质在该部件的所有均质材料中的含量低于 GB/T 26572 标准规定的限量要求。
O: Indicates that the hazardous substance contained in all of the homogeneous materials for this part is below the limit requirement in GB/T 26572.

X : 表示该有害物质在该部件的至少一种均质材料中的含量超出 GB/T26572 标准规定的限量要求。
X: Indicates that the hazardous substance contained in at least one of the homogeneous materials used for this part is above the limit requirement of GB/T26572.

NOTES: These products are EU RoHS compliant, the following Exemptions apply:
6(b) Lead as an alloying element in aluminium containing up to 0.4% by weight.
6(c) Copper alloy containing up to 4% lead by weight

Packaging Information

Pallet	Over-shipper	Protection Pieces	Support Braces
			
Recyclable Natural Wood	Recyclable Cardboard	Recyclable Polypropylene	Recyclable Mild Steel

Contents

Copyright notice.....	2
Trademark credits.....	2
Associated publications.....	2
List of Figures.....	9
List of Tables.....	10
Safety and compliance	12
Definition of Warnings and Cautions.....	12
Safety symbols.....	12
Overview of the nEXT85	13
Motor controller.....	14
Operational features.....	15
Power limit setting.....	15
Standby speed.....	15
Timer.....	15
Analogue output.....	16
Automatic vent options.....	16
Normal speed setting.....	16
Electronic braking.....	17
Logic interface.....	17
USB interface.....	18
Parallel control and monitoring.....	18
Serial control and monitoring.....	18
Serial control with parallel monitoring.....	19
Parallel control with serial monitoring or serial configuration.....	19
Motor controller configuration (serial configuration).....	19
Install the nEXT85	20
Unpack and inspect.....	20
Connect to the vacuum system.....	21
Remove and replace the inlet screen.....	22
Mount the pump.....	23
Backing port connection.....	25
Interstage connection.....	26
Purge gas connection.....	26
Recommended purge gas flow.....	26
Connect the purge gas.....	26
Electrical installation of the nEXT85	26
Earth (ground) connections.....	27
TIC or TAG logic interface connections.....	27
Connect the logic interface to control equipment.....	27
Connect the parallel control and monitoring.....	28
Connection for serial control and monitoring.....	29
Connect the serial interface to the customer control equipment.....	30
Serial enable.....	32
Connection for mixed parallel and serial operation.....	32

Cooling.....	33
Cooling requirements.....	33
Forced air cooling.....	34
Water cooling.....	34
Configuration	36
Configure the pump using serial commands.....	36
Message structure.....	37
Command and reply table definitions.....	37
Power limit setting.....	38
Powering a fan from the motor controller.....	38
Controlled venting options.....	39
Standby speed setting.....	40
Normal speed setting.....	40
Timer setting and options.....	41
Analogue signal options.....	42
Electronic braking options.....	42
Factory settings.....	43
Assigning a multi-drop address.....	43
Configure the pump using a TIC.....	44
Operation of the nEXT85	46
Before starting the pump.....	46
Close the vent valve.....	46
Pre-start sequence.....	46
Vent options, vent valve connection and control.....	47
Manual vent valve.....	47
TAV5 solenoid vent valve.....	47
Vent valve control.....	48
Alternative valve connected to the vacuum system.....	50
Operation with parallel control and monitoring.....	50
Start the pump with parallel control.....	50
Run the pump at standby speed with parallel control.....	51
Stop the pump with parallel monitoring.....	51
Parallel monitoring.....	51
Operation with serial control and monitoring.....	52
Delayed start with serial control.....	52
Start the pump with serial control.....	52
Run the pump at standby speed with serial control.....	53
Stop the pump with serial control.....	53
Monitor temperature readings with serial control.....	53
Monitor link parameter readings with serial control.....	53
Monitor measured motor speed with serial control.....	54
Mixed parallel and serial operation.....	54
Operation with a TIC or TAG.....	55
Decelerating and venting.....	56
Operation at extreme conditions.....	56
Operation with high inlet pressure.....	56
Operation at high temperatures.....	56
Protection against over-speed.....	57
Electrical supply failure.....	57
Bakeout.....	58
Shut down the pump manually.....	59

Maintain the nEXT85	60
Bearing and oil cartridge maintenance.....	61
Rotor life.....	61
Cleaning the pump.....	61
Decoding service status words.....	61
Controller run time.....	62
Pump run time.....	63
Pump cycles.....	63
Bearing run time.....	63
Oil cartridge run time.....	63
Storage	65
Disposal	66
Troubleshooting	67
The controller LEDs do not flash for 0.5 seconds when system switched on.....	67
The pump does not rotate after a parallel start command is supplied.....	67
The pump does not rotate after a serial start command is sent.....	67
The pump does not respond in multi- drop mode.....	68
The green Normal LED does not light or the pump is not rotating at full speed or the pump fails whilst running.....	68
Ultimate pressure cannot be reached.....	68
The pump is very noisy or there is excessive vibration or both.....	69
No serial comms.....	69
Fail signal or standby signal not working.....	69
Yellow service LED is flashing a repeated sequence.....	69
The red alarm LED is on.....	70
The red alarm LED is flashing.....	70
Any other problems.....	70
Command set error codes.....	70
Flashing service codes.....	71
Flashing error codes.....	71
Decoding system status words.....	72
Service information.....	75
Service	76
Returning a pump for service.....	76
Bearing and oil cartridge on-site maintenance.....	76
Spares	78
Inlet screen.....	78
Inlet strainer.....	78
Inlet flange seals and integrated inlet screens.....	78
NW16 and NW25 ports.....	79
Accessories for the nEXT85	80
Air cooler.....	81

Water cooler.....	81
Flange heater.....	82
TAV5 vent valve.....	82
VRX vent restrictor.....	83
Vent port adaptor.....	83
PRX purge restrictor.....	83
Interface cable.....	83
nST PC program.....	84
Auxiliary connector.....	84
Auxiliary extension cable.....	84
Auxiliary 'Y' cable adaptor.....	85
Base mounting adaptor.....	85
Technical Reference	86
Operating and storage conditions.....	86
General technical data.....	86
Pump performance data.....	88
Pumped media.....	92
Venting gas specification and vent control data.....	93
Materials exposed to gases pumped.....	94
Purge gas specification.....	94
Water cooling.....	95
Electrical data.....	95
Logic interface connector.....	96
Serial protocol.....	98
Command set.....	99
Multi-drop operation.....	103
Motor controller auxiliary connector socket.....	105
Indicator LEDs.....	106
Definitions.....	107

List of Figures

Figure 1: Typical pumping system with a nEXT pump.....	21
Figure 2: Allowable pump orientation.....	25
Figure 3: Logic interface connections - parallel control.....	29
Figure 4: Motor controller status information.....	31
Figure 5: Logic interface connections - RS232 serial control.....	31
Figure 6: Logic interface connections - RS485 serial control.....	32
Figure 7: Logic interface connection - mixed parallel and serial operation.....	33
Figure 8: Auxiliary interface connection.....	50
Figure 9: Serial and parallel control flowchart.....	55
Figure 10: Accessories.....	81
Figure 11: Dimensions - nEXT85 ISO63.....	86
Figure 12: Dimensions - nEXT85 CF63.....	87
Figure 13: Dimensions - nEXT85 ISO100.....	87
Figure 14: Dimensions - nEXT85 DN40.....	87
Figure 15: Typical base view.....	88
Figure 16: nEXT85 pumping speed versus inlet pressure performance graph.....	89
Figure 17: nEXT85 compression ratio versus backing pressure graph.....	89
Figure 18: Max allowed rate of pressure rise during venting: pressure against time (pump initially at full speed).....	94
Figure 19: Maximum relative humidity to avoid condensation with water cooling.....	95
Figure 20: Interface circuits for nEXT turbo pump controllers.....	98
Figure 21: Conceptual diagram for multi-drop connection using RS232 interface.....	104
Figure 22: RS485 multi-drop connection.....	105
Figure 23: Motor controller connector showing pin numbers.....	106
Figure 24: HS1 Form.....	108
Figure 25: HS2 Form.....	109

List of Tables

Table 1: Checklist of items.....	20
Table 2: Water cooling block supply requirements.....	35
Table 3: Command abbreviations.....	37
Table 4: Power limit setting.....	38
Table 5: Analogue signal options.....	42
Table 6: Vent valve options.....	48
Table 7: Valve types.....	49
Table 8: Vent restrictor orifice diameter if venting the vacuum system chamber.....	50
Table 9: Serial enable matrix.....	54
Table 10: Behaviour of a pump when the power is re-instated after an electrical supply failure.....	58
Table 11: Service flags.....	62
Table 12: Command set error codes.....	70
Table 13: Flashing service codes.....	71
Table 14: Flashing error codes.....	71
Table 15: Hexadecimal conversion table.....	73
Table 16: Status flag.....	73
Table 17: Example decoding of system status words.....	74
Table 18: Service tool kits.....	77
Table 19: Service kits.....	77
Table 20: Inlet screens.....	78
Table 21: Inlet strainers.....	78
Table 22: Inlet flange seals and integrated inlet screens.....	78
Table 23: Inlet strainers.....	79
Table 24: Air cooler.....	81
Table 25: Water cooler.....	82
Table 26: Flange heater.....	82
Table 27: TAV5 vent valve and vent port adaptor.....	82
Table 28: VRX vent restrictor.....	83
Table 29: Vent port adaptor.....	83
Table 30: PRX purge restrictor.....	83
Table 31: Interface cable.....	83
Table 32: Auxiliary connector.....	84
Table 33: Auxiliary extension cable.....	84
Table 34: Auxiliary 'Y' cable adaptor.....	85
Table 35: Base mounting adaptor.....	85
Table 36: Operating and storage conditions.....	86
Table 37: General technical data.....	86
Table 38: Pump performance data.....	88
Table 39: Maximum transient backing pressure at zero inlet flow.....	89
Table 40: Maximum continuous backing pressure nEXT85D at zero inlet flow.....	90
Table 41: Maximum continuous inlet pressure/throughput nEXT85D - Nitrogen.....	90
Table 42: Maximum continuous inlet pressure/throughput nEXT85D - Helium.....	91
Table 43: Maximum continuous inlet pressure/throughput nEXT85D - Argon.....	91
Table 44: General pump performance data.....	92
Table 45: Vent gas specification and vent control.....	93
Table 46: Purge gas specification.....	94
Table 47: Water cooling block supply requirements.....	95
Table 48: Logic interface technical data.....	96
Table 49: Logic interface connector pins.....	97

Table 50: Summary of commands that can be sent to the pump.....	99
Table 51: Summary of commands that can be sent to the pump - Vent options 1.....	102
Table 52: Summary of commands that can be sent to the pump - Vent options 2.....	103
Table 53: Motor controller technical data.....	105
Table 54: Indicator LEDs.....	106

Safety and compliance

Definition of Warnings and Cautions

Important safety information is highlighted as WARNING and CAUTION instructions; these instructions must be obeyed.

The use of WARNINGS and CAUTIONS is defined below.



WARNING:

Warnings are given where failure to observe the instruction could result in injury or death to people. The actual symbol shown varies according to the hazard.









CAUTION:

Cautions are given where failure to observe the instruction could result in damage to the equipment, associated equipment or process.

Safety symbols

The safety symbols on the products denote areas where care and attention is required.

The following safety symbols may be used on the nEXT85 and throughout the product documentation.

	<p>Warning/Caution</p> <p>An appropriate safety instruction should be followed or caution to a potential hazard exists.</p>
	<p>Warning - Dangerous Voltage</p> <p>Indicates hazards arising from dangerous voltages.</p>
	<p>Warning - Hot Surfaces</p> <p>Indicates that the marked item may be hot and should not be touched without taking precautions.</p>
	<p>Protective conductor (ground)</p> <p>To identify any terminal intended for connection to an external conductor for protection against electric shock in case of a fault, or the terminal of a protective earth (ground) electrode.</p>
	<p>Warning - Risk of Explosion</p> <p>Indicates the potential risk of explosion.</p>
	<p>Warning - Use protective equipment</p> <p>Indicates that appropriate protective equipment must be used.</p>

Overview of the nEXT85

A nEXT85 pump consists of a turbomolecular pump with a permanently attached motor controller containing drive electronics.

The motor controller controls the electrical supply to the pump. It allows manual adjustment of standby speed, all other controls can only be operated through the logic interface. To operate the nEXT85 pump, connect it to the customer control equipment and power supply or, alternatively, use the Edwards TIC Turbo Instrument Controller, TIC Turbo Controller or TAG Controller (see [Electrical data](#) on page 95).



WARNING:

Improper use of the equipment could cause damage to it or injury to people. The user is responsible for the safe operation, installation and monitoring of the system.



WARNING:

The pump and motor controller contains electrolytic capacitors and, under certain fault conditions, may emit dangerous fumes. Ensure that the pump and motor controller is operated in a well-ventilated area.



CAUTION:

Do not attempt to separate the motor controller from the pump as this will cause damage to the electrical connections.

The motor controller drives the brush-less motor in the pump. There are two main variants of the nEXT85 pump:

- The 'D' or 'Duplex' variant contains turbomolecular blades and a drag mechanism allowing operation at higher backing pressures than pure turbomolecular pumps.
- The 'H' or 'High Compression' variant employs the same technology as the 'D' variant, but is tuned to deliver higher compression.

Also available is an 'iD' or 'iH' interstage variant, which provides an interstage port between the turbomolecular blades and drag mechanism.

nEXT85 pumps are supplied with an inlet screen fitted into the centering O-ring for ISO and NW40 version pumps and into the envelope for CF version pumps. The inlet screen protects the pump against damage that would be caused by debris entering the pump.

The nEXT85 pumps have a vent port for venting the pump and vacuum system to atmospheric pressure. The pump is supplied with a manual vent valve fitted; this can be replaced with a TAV5 solenoid-operated vent valve (available as accessories - refer to [Accessories for the nEXT85](#) on page 80). The TAV valve can be directly controlled by the on-board motor controller.

The nEXT85 pumps have a purge port: an inert purge gas can be introduced to protect the bearing and motor from corrosion. An optional vent port adapter and purge restrictor can be fitted to the purge port to control the flow rate of the purge gas and to filter the gas supply. Additionally this may be used to optimise the performance of the pump, for example with low molecular mass gases. Refer to [Accessories for the nEXT85](#) on page 80.

A forced air cooling kit and a water-cooling block are available as optional accessories to cool the nEXT85 pumps. Refer to [Accessories for the nEXT85](#) on page 80.

Motor controller

The motor controller contains the drive electronics that control the pump operation, the TAV vent valve and the air cooler.



CAUTION:

Do not disconnect the pump from the electrical supply until the pump has stopped completely.

There is an auxiliary connector socket on the side of the motor controller where the TAV vent valve and the Air cooler can be plugged into. (Refer to [Motor controller auxiliary connector socket](#) on page 105).

There is a USB port (item 9 in [Figure 4](#) on page 31) which is a service port to be used with the Edwards nST PC software, using a standard micro-USB cable. This will enable the pump to be configured, monitored and upgraded without disconnecting from the 24 - 48 V d.c. supply. This software is available for download from the Edwards' Upgrade website: www.upgrades.edwardsvacuum.com

Currently, nST software requires a free license in order to be used. To obtain a free license follow the onscreen instructions, fill out the user data form and then send the automatically generated email to Edwards.

The motor controller has five indicator LEDs that signal the general status, operation, service status of the pump and serial communication. The LEDs can be used for fault finding if a problem should occur. (Refer to [Indicator LEDs](#) on page 106).

The motor controller has a number of built-in safety features to protect the nEXT85 pumps from damage in the event of sustained high pressure or temperature.

- The electronics constantly monitors the temperature inside the motor controller and the temperatures of the rotor and motor within the pump. If either part becomes too hot, the motor controller reduces the power supplied to the pump motor and the pump speed will drop. If the pump rotational speed falls below 50% of full speed, the electronics may trip into a Fail condition, depending on the system configuration. (Refer to [Timer](#) on page 15).
- If the pump inlet pressure increases, the power supplied to the pump motor increases to counteract the gas frictional load. However, when the built-in maximum power limit is reached, the speed of the pump will start to drop. If the pump rotational speed falls below 50% full speed, the electronics may trip into Fail condition, depending on how the system has been configured. (Refer to [Timer](#) on page 15).
- In the event of an electrical supply failure, the motor controller uses the motor within the pump as a generator. This means the nEXT85 pumps have their own regenerative supply and do not require a separate battery for emergency power backup. The regenerated energy is used to maintain the electrical supply to the motor controller and any vent valve or fan attached to the motor controller connector until the pump speed falls to below 50% of full rotational speed: this will ensure that when using a normally open vent valve it will remain shut until below 50% of full rotational speed and will prevent the pump from venting at full speed. It also ensures that the serial link and signals on the parallel interface remain active until the pump speed falls below 50%.

Operational features

In addition to the basic start and stop commands, the nEXT85 pumps have several other features that allow pump operation to be tailored to a particular application.

Power limit setting

Use this feature to select the maximum power that will be drawn by the pump. The more power supplied, the quicker the pump will accelerate to reach full speed.

If the application requires fast cycling or higher gas loads, set the power limit to the maximum value. If ramp time is not important in the application, use a lower power limit, down to a minimum value (refer to [Table 4](#) on page 38). Also ensure there is sufficient cooling for the application.

Ensure that the power supply is capable of delivering sufficient power to the nEXT85 pump. By choosing a lower power limit setting, a smaller power supply may be used. For more information, refer to [Electrical data](#) on page 95.

Standby speed

In standby mode, the pump rotational speed is lower than the full rotational speed. The default setting for standby speed is 70% of full speed.

To run at standby speed, the pump must also be in the start condition.

If the application does not require the pump to be running at maximum speed at all times, use the standby speed feature rather than switching the pump off. This feature can be used for vacuum system tuning or as a system power saving option.

The standby speed is a user-selectable value (refer to [Standby speed setting](#) on page 40).

Timer

When the pump is started, an internal timer is automatically started within the motor controller. The default timer setting is 8 minutes.

If the pump fails to reach 50% of full rotational speed within the timeout period, the motor controller will signal a fail and will decelerate the pump to rest. This feature prevents the motor controller from driving the pump at maximum power for a long time. The pump may fail to reach 50% speed if the gas load is too high (for example if there is a leak in the system), if the backing pump fails or if the pump is too hot.

The timeout period is a user-selectable feature (refer to [Timer setting and options](#) on page 41). If the application requires the pump to ramp up slowly, extend the timeout period. The timer is permanently enabled for ramp-up.

The timer has an additional function; if the pump rotational speed drops below 50% of full speed for any reason, the pump time can be set to recover rather than trigger a fail condition. The timer starts as soon as the speed drops to below 50% full speed. If, during the timeout period, the pump recovers to above 50% full speed then the timer will be reset. If the pump rotational speed fails to recover by the end of the timeout period, the motor controller will trigger a fail condition and will decelerate the pump to rest.

When the pump is shipped, the timer function is enabled, however, it can be disabled. With the timer disabled, the pump will fail and decelerate to rest as soon as pump rotational speed falls below 50%.

Analogue output

The motor controller produces an analogue output for monitoring system parameters.

The five different system parameters are:

- Measured pump rotational speed (default condition)
- Measured link power
- Measured motor temperature
- Measured motor controller temperature
- Measured rotor temperature

The analogue output signal ranges from 0 to 10 V and is directly proportional to the system parameter (refer to [Logic interface](#) on page 17).

Connect the analogue output to a suitable meter or indicator to display the appropriate system parameter or connect it to the customer control equipment (for example, to operate other components in the pumping system at preset values).

Only one system parameter can be monitored at a time using the analogue output. However, it is easy to configure the motor controller to monitor a different system parameter (refer to [Analogue signal options](#) on page 42).

Automatic vent options

An Edwards TAV vent valve can be connected directly to the motor controller. The motor controller can provide a number of different venting options and can be configured for both a normally closed and a normally open vent valve.

The motor controller can control the rate of venting. Using this feature the pump can be vented from full rotational speed in a controlled manner that will not damage the pump bearings. Once the pump rotational speed has dropped to below 50% of maximum speed, it is safe to hard vent (open the vent valve fully).

There are many venting options available, including:

- Hard vent when rotational speed drops below 50%
- Controlled vent when above 50% speed and hard vent below 50% speed
- Hard vent immediately through a suitable restrictor

Controlled venting gives the benefit of a quicker ramp down time by controlling the vent rate through a single large orifice across the pump speed range. A full list of the venting options is given in [Vent options, vent valve connection and control](#) on page 47.

In addition there is a feature that allows a delayed start of the nEXT85 pump. With this feature, the vent valve can be closed before starting the pump. This allows the backing pump to reduce the pressure in the vacuum system before starting the nEXT85 pump.

Both a TAV and a cooling fan can be controlled at the same time using the 'Y' cable adaptor. No configuration is required.

Normal speed setting

The normal speed is a user-selectable parameter that can be set from 50% to 100% of full rotational speed.

When the pump reaches normal speed, a signal is available on the normal pin of the logic interface connector. This signal can be used to control the application since it shows that pump speed, and therefore vacuum performance, has reached a specific minimum level. The default setting is 80% of full rotational speed. Refer to [Normal speed setting](#) on page 40 for instructions on altering the normal speed setting.

Electronic braking

The pump has a user selectable electronic braking option that is disabled by default. With this option disabled, the pump will draw power from the electrical supply when accelerating and running.

Whilst decelerating the pump will coast down and no power will be returned to the electrical supply.

The electronic braking option may be enabled to reduce the pump deceleration time and to recover some energy from the pump. This is achieved by returning power from the pump to the electrical supply. The rate at which electrical energy is returned to the supply is regulated to the voltages shown:

Voltage range	Below 21.6 V d.c. (24 V d.c. -10%)	21.6 V d.c. to 26.4 V d.c.	26.4 V d.c. to 38.4 V d.c.	38.4 V d.c. to 50.4 V d.c.	Above 50.4 V d.c. (48 V d.c. +5%)
Returned electronic braking voltage	Outside working range for pump	24 V d.c. +10%	Electronic braking not functional	48 V d.c. +10%	Outside working range for pump

In order to achieve the fastest electronic braking times there must be somewhere for the returned power to go, such as:

- A supply capable of receiving the returned power
- Other devices sharing the same electrical supply bus with the pump
- A suitable 2 A load when decelerating the pump

Logic interface

The motor controller can only be operated through the logic interface. There are three types signals on the logic interface.

The signal types are:

- Control inputs: these are switch-type signals that are used to control the pump
- Status outputs: these outputs identify the status of the system
- Analogue output: this provides a 0 – 10 V output for a number of pump parameters

The logic interface has been designed to support both serial and parallel control and monitoring, operating through one connector. For serial control either RS232 (default) or RS485 can be selected using the RS485/RS232 slide switch located on the motor controller (refer to [Connection for serial control and monitoring](#) on page 29).

The logic interface can be plugged directly into the Edwards TIC Turbo Controller, TIC Turbo Instrument Controller or TAG Controller and then use the functionality that they provide. Alternatively, the logic interface can be connected to the customer control system.

For more information about the logic interface, refer to [Logic interface connector](#) on page 96.

USB interface

The USB service port is designed to work in conjunction with Edwards nST PC software. The primary purpose of this interface is to allow easy configuration of the nEXT85 pump.

Some operational capabilities are provided, including START/STOP to enable pump operational checks to be made via the USB service port. However it is not intended as an industrial control interface for unattended machine to machine (M2M) control.

The USB service port will support communications concurrently with the serial interface in the logic interface connector. This enables the pump status and logs to be reviewed, and the pump to be configured while the pump is installed and running.

The USB service port should only be used when the 24 - 48 V d.c. power is applied. Use of the USB service port without 24 - 48 V d.c. power risks corruption of the pump controller memory.

Parallel control and monitoring

The simple parallel interface is a quick and easy way to control the pump.

This is the same interface used on existing 24 V Edwards Turbo Pumps. The controls that are available to use are start and standby. The system status can be monitored using the normal, fail and analogue output signals.

Refer to [Connect the parallel control and monitoring](#) on page 28 for more detailed instructions of how to use the parallel interface.

A system operating with only a parallel connection is not capable of adjusting the configuration settings stored in the motor controller (for example, power limit setting or controlled venting options). In this case, all these features would be at their factory default settings. It is possible to manually adjust the standby speed if standby mode is selected, however, the motor controller should be configured separately before fitting the pump to the system. This is covered in more detail in [Parallel control with serial monitoring or serial configuration](#) on page 19 and [Motor controller configuration \(serial configuration\)](#) on page 19.

Serial control and monitoring

The serial communications link provides complete control and monitoring by using just three signal lines.

The serial data lines share the same connector pins as the parallel signals standby and fail. The serial data lines can be configured to provide an RS485 compliant or RS232 compatible interface by setting the position of the RS485/RS232 slide switch (refer to [Connection for serial control and monitoring](#) on page 29).

The serial enable signal MUST be linked to 0 V for the system to accept commands from the serial link. This is a safety feature and acts as an interlock. For pure serial control, the parallel start signal will be left unconnected.

The motor controller will still provide the normal and analogue signals on the logic interface connector even when operating under serial control. The status of the normal signal and the value of the system parameter on the analogue output can also be obtained by interrogating the system status via the serial link.

For more information about the serial interface, refer to [Connection for serial control and monitoring](#) on page 29.

Serial control with parallel monitoring

Normal and analogue signals remain available when using serial control. It is possible to control the pump via the serial link whilst monitoring these signals in the parallel interface.

The serial link uses the same connector pins as the parallel signals standby and fail so these parallel control and monitoring signals are not available. The serial enable signal must be linked to 0 V and the parallel start signal will be left unconnected.

Parallel control with serial monitoring or serial configuration

Use this configuration to operate the pump in parallel control mode, with the option to adjust the configuration settings stored in the motor controller or to monitor operational status of the pump through the serial link or via the USB service port.

If using the USB service port, in conjunction with Edwards nST PC software, the serial enable signal does not need to be linked to 0 V for the serial communications to take place. Whilst operating under parallel control with the USB service port, all of the parallel control and monitoring signals are available (as described in [Parallel control and monitoring](#) on page 18), including the standby control line and fail monitoring line.

If using the serial link, the serial enable signal must be linked to 0 V for serial communications to take place. Whilst operating under parallel control with the serial link active, the parallel start control signal is available (as described in [Parallel control and monitoring](#) on page 18) but the standby control line is not since it is used as a serial data line.

If the serial enable line is deactivated at any time whilst the RS485/RS232 slide switch is in the RS232 position, the serial link should also be disconnected. Edwards suggests making a special cable for serial communications that includes a link between serial enable and 0 V. This way, serial enable is automatically activated when the cable is connected and then deactivated when the cable is removed.

Motor controller configuration (serial configuration)

All the configuration settings stored within the motor controller are retained when power to the pump is removed so that it is possible to use a separate system to configure the motor controller before fitting the pump to the application.

This gives the benefit of tailoring the pump functionality to a customer application and allows the pump to be operated using a simple parallel interface system.

To configure the pump, either use a customer simple serial system, via the serial link, or use the Edwards TIC Turbo Controller, TIC Turbo Instrument Controller or TAG Controller. The TICs have a feature which allows storage of a nEXT85 pump's configuration. The configuration can then be downloaded to another nEXT85 pump. This is useful when configuring a number of nEXT85 pumps with the same settings before they are fitted to a system.

The USB service port can also be used in conjunction with the Edwards nST PC software to configure the nEXT85 pump. The configuration can then be downloaded to another nEXT85 pump, in the same way it can with a TIC, which is useful when configuring a number of nEXT85 pumps.

Install the nEXT85

Unpack and inspect

The pump is supplied in a cardboard box and does not require lifting equipment.



WARNING:

Appropriate care should be taken when lifting and moving the pump to avoid injury. The user must adhere to manual handling guidelines.



WARNING:

The motor controller cable should not be used as a lifting device. Do not attempt to lift or support the pump using the cable.



CAUTION:

Local legislation concerning the impact of the pump on the environment must be followed when installing and removing the pump.

1. Take care when unpacking the pump to avoid excessive shocks which could damage the bearings and reduce the life of the pump. The pump is supplied with the inlets and outlet sealed to prevent entry of dust and vapour. Do not remove these seals until ready to install the pump on the vacuum system.
2. Open the cardboard box from the top. Once the box lid is open, remove the upper pieces of foam and cut open the bag.
3. If the pump is damaged, notify the supplier and the carrier in writing within three days; state the item number of the pump together with the order number and the supplier's invoice number. Retain all packing materials for inspection. Do not use the pump if it is damaged.
4. Check that the package contains the items listed in [Table 1](#) on page 20. If any of these items are missing, notify the supplier in writing within three days.
5. If the pump is not to be used immediately, store in suitable conditions as described in [Storage](#) on page 65.
6. It is advised to retain all packing materials for use, should you return the pump for service.

Table 1 Checklist of items

Quantity	Description	Check
1	nEXT85 Turbomolecular Vacuum Pump	<input type="checkbox"/>
1	Integral mesh centring ring O-ring seal (ISO variants only. Screen will be fitted to CF pumps.)	<input type="checkbox"/>

Figure 1 Typical pumping system with a nEXT pump

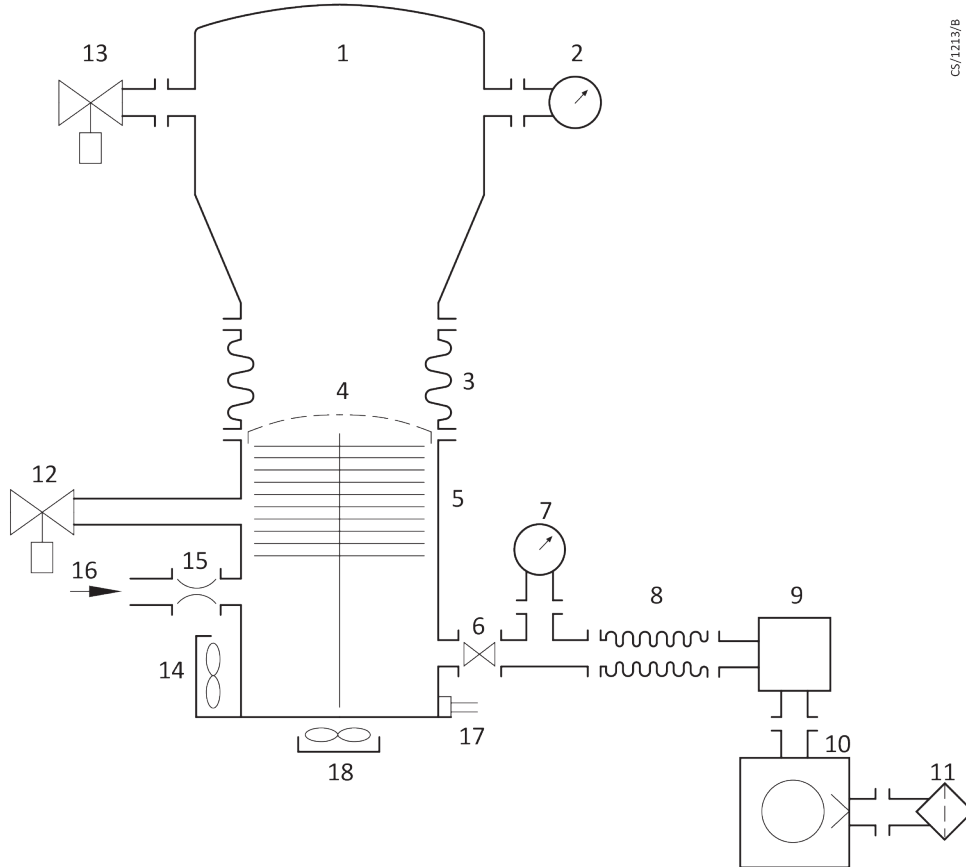

CS/1213/B

- | | |
|------------------------------------|--|
| 1. Vacuum system | 10. Backing pump (Rotary vane or scroll pump) |
| 2. High vacuum gauge | 11. Mist filter (for rotary pump) / silencer (for scroll pump) |
| 3. Vibration damper | 12. Vent valve |
| 4. Inlet screen | 13. Alternative position for vent valve |
| 5. nEXT pump | 14. Radial air cooler |
| 6. Backing valve | 15. PRX purge restrictor |
| 7. Vacuum gauge | 16. Regulated purge gas supply |
| 8. Flexible bellows | 17. WCX water cooler and connections |
| 9. Foreline trap (for rotary pump) | 18. Axial air cooler |

Note:

An interstage port is available on the 'i' variant but is not shown.

Connect to the vacuum system



WARNING:

Install the pump in the vacuum system before connecting the motor controller to the power supply. This will ensure that the pump cannot operate and injure people during installation.

**WARNING:**

Ensure that any cabling and or pipe work attached to the pump are routed carefully to avoid causing a slip/trip hazard and to prevent any damage to the cable.

**WARNING:**

Under no circumstances must any part of the human body be exposed to a vacuum.

<i>Remove and replace the inlet screen</i>	The inlet screen is supplied fitted on CF pumps only. Remove the inlet screen only if there is no possibility that debris can fall into the pump. If the inlet screen is removed, the pumping speed will increase by up to 20%.
<i>Mount the pump</i>	The pump can be base or flange mounted using only the specified fixings. The NW40 inlet variant cannot be flange mounted.
<i>Backing port connection</i>	The pump is suitable for use with Edwards Rotary Vane, Scroll or diaphragm backing pumps. System performance may depend upon which pump is used. Contact Edwards when selecting an appropriate backing pump for the application.
<i>Interstage connection</i>	Interstage connection is only possible using an 'i' nEXT pump to back another pump.

Remove and replace the inlet screen

The inlet screen is supplied fitted on CF pumps only. Remove the inlet screen only if there is no possibility that debris can fall into the pump. If the inlet screen is removed, the pumping speed will increase by up to 20%.

**WARNING:**

The rotor blades on the pump are very sharp. The absence or removal of inlet screens or strainers exposes the risk of injury from sharp edges or moving parts.

**WARNING:**

Care must be taken to avoid foreign objects from entering the pump during installation. The pump is supplied with either an integral mesh centring O-ring seal or a pre-fitted mesh screen. This must be fitted during installation.

**WARNING:**

In the unlikely event of pump fracture, it is possible that the inlet screen may not trap all of the debris within the pump. Ensure that the system can contain any debris that may escape from the pump.

**WARNING:**

The inlet screen is a coarse filter for debris and should not be used as a finger guard.

**CAUTION:**

The screen protects the pump from contamination. Do not remove the inlet screen until the pump is about to be mounted onto the system.

1. To remove the inlet screen from a pump with CF inlet flange, use a bent wire hook or small screwdriver to carefully lever the inlet screen out from the inlet flange.
2. To replace an inlet screen, locate it as centrally as possible over the CF inlet flange and then, with fingers applying equal pressure around the edge of the screen, push it firmly downwards.

If they are not already in place, the tangs must be snapped into the locating groove in the inlet flange using a suitable tool to press them into position.

For ISO flanged pumps, Edwards supplies a combination inlet screen/trapped O-ring.

Mount the pump

The pump can be base or flange mounted using only the specified fixings. The NW40 inlet variant cannot be flange mounted.

**WARNING:**

Ensure the pump is securely fixed to the vacuum system through its inlet flange or base using all available mounting points. If the pump were to seize when not securely mounted or restrained, the stored energy of the rotor could cause rapid movement of the pump, which may cause further damage and injury to personnel.

**WARNING:**

If a pump fails it is likely to eject parts into the vacuum system onto which it is mounted. The customer must ensure that a hazard is not created should this occur.. Edwards accepts no responsibility should injury or damage to persons, equipment or property occur as a result of a failed pump ejecting parts into a customer's system.

1. To base mount the pump, 4 x M5 bolts (Class 12.9) must be used with 8 mm thread engagement.
2. To flange mount the pump, 4 x Edwards Hooded Claw Clamps (C10007090) must be used, tightened to 10 Nm.

Base mounting

The base of the nEXT85 pump can be fixed to a firm support using the tapped fixing holes.

 **Note:**

The four rubber feet must be removed from the four tapped fixing holes before the pump can be base mounted.

The following requirements should be met to ensure the pump remains secure in the event of a total pump seizure:

Fixing screws:	4 off M5 to ISO898-1 strength class 12.9 (nominal tensile strength 1200 MPa)
PCD (Pitch Circle Diameter):	79 mm spaced equally, see Figure 15 on page 88

Screw engagement length:	8 mm
Fastening torque:	6 Nm (0.612 kgf.m)

Inlet connection and pump orientation

The pump can be securely fixed to the vacuum system via the inlet flange. Do not operate the pump in an orientation that is greater than horizontal.



CAUTION:

It is important that the pump be correctly orientated. The pump must only be orientated in a horizontal or vertical position. Incorrect orientation may lead to premature pump failure. Only store the pump such that the pump body is either horizontally in line with or below the main inlet flange of the pump. If the pump is operated or stored at any time with the pump body above the main inlet flange it is possible for oil - used to lubricate the lower bearing - to escape from a reservoir at the base of the pump into the pump mechanism or vacuum system. This may reduce performance and bearing life.

See [Figure 2](#) on page 25 for allowable pump orientation.

Make sure that the pump inlet and all components fitted to the pump inlet are clean and dust-free. If the pump inlet is not kept clean, the pump-down time may be increased.

The inlet connections for the nEXT85 pumps are either ISO flange, CF flange or NW40 flange.

- If the pump has a CF flange, use the copper compression gasket supplied with the pump and use a full complement of bolts to connect the inlet flange of the pump to the vacuum system. A minimum grade screw of ISO898-1 class 5.6 (500 MPa tensile strength) is recommended.
- If the pump has an ISO flange, use the Edwards combination inlet screen/trapped O-ring supplied with the pump and use a minimum of four claw clamps (each torqued to 10 Nm) to connect the inlet flange of the pump to the vacuum system. Alternatively, use a rotatable collar and the combined inlet screen and trapped O-ring supplied with the pump to connect the inlet flange of the pump to the vacuum system; use a full complement of minimum ISO class 5.6 bolts torqued to 10 Nm with the rotatable collar.
- If the pump has an NW flange, use the centring ring supplied with the pump and a metal NW clamp to connect the inlet flange of the pump to the vacuum system. In this case, the base of the pump must also be fixed to a firm support as described in [Base mounting](#) on page 23.

All inlet flange bolts must be re-tightened once the system is under vacuum. Ensure that no torques or other forces are transmitted to the pump from the vacuum system or the associated pipelines.

Figure 2 Allowable pump orientation

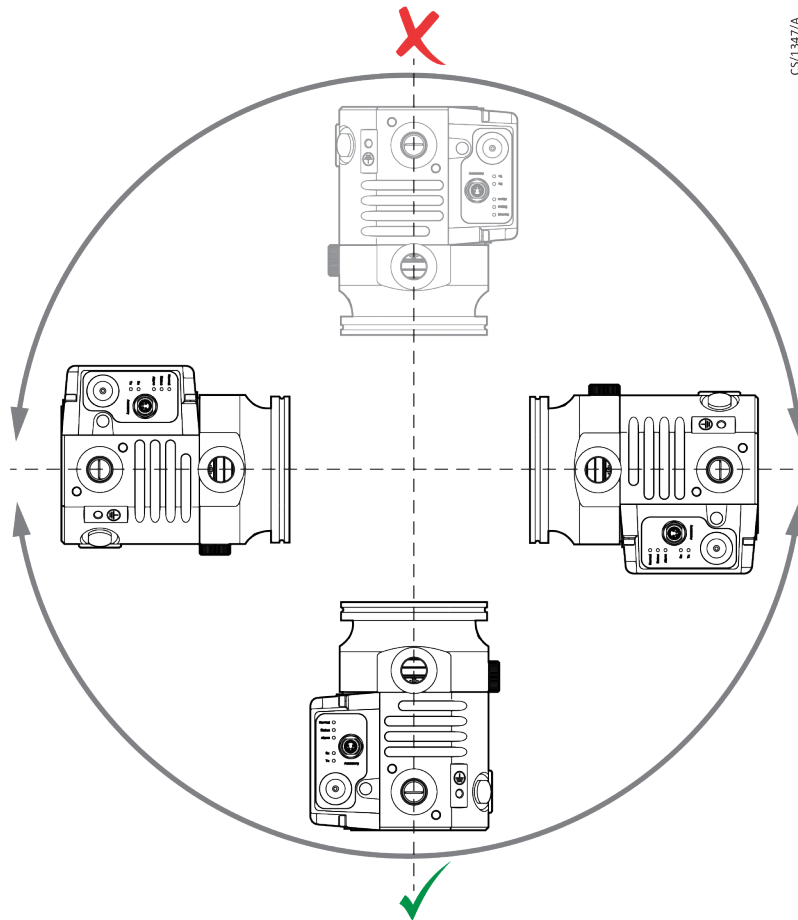

Backing port connection

The pump is suitable for use with Edwards Rotary Vane, Scroll or diaphragm backing pumps. System performance may depend upon which pump is used. Contact Edwards when selecting an appropriate backing pump for the application.



WARNING:

The customer must ensure safe ducting of the backing line if oil mist or hazardous substances are present.



WARNING:

The pump must not be operated or vented from a positive pressure gas supply when the backing line is restricted or blocked.



CAUTION:

Do not use the pump with a backing pressure below 5×10^{-4} mbar (5×10^{-2} Pa). Lower backing pressures will increase the evaporation rate of the lubricating oil reducing the bearing life.

Use suitable vacuum tubing and connectors to connect the NW25 flange of the backing port to the backing pump. If necessary, use flexible pipe or bellows to reduce the transmission of vibration from the backing pump to the pump.

Interstage connection

Interstage connection is only possible using an 'i' nEXT pump to back another pump.

1. Use suitable vacuum tube and connectors to connect the interstage port to the vacuum system or to the outlet flange of another turbo or compound turbomolecular pump.
2. Leave the inlet strainer in the interstage port, unless it is certain that debris cannot be drawn into the interstage port.

Purge gas connection

Recommended purge gas flow

The recommended purge gas flow for typical applications is 25 sccm (0.42 mbar l s⁻¹, 42 Pa l s⁻¹). This flow will protect the pump when pumping oxygen in concentrations above 20% by volume.

The flow rate of the purge gas must be limited to the allowed range, specified in [Purge gas specification](#) on page 94. To limit the flow rate, use a flow controller or a pressure regulator and calibrated flow restrictor. The PRX10 purge restrictor accessory (refer to [Accessories for the nEXT85](#) on page 80) is suitable for this purpose.

Connect the purge gas

Connect a purge gas supply to protect the pump when pumping oxygen in concentrations above 20% by volume.

Note:

The purge gas must comply with the specification given in [Purge gas specification](#) on page 94.

1. To supply a purge gas to the pump, remove the plug fitted in the purge port.
2. To fit a vent port adaptor (refer to [Accessories for the nEXT85](#) on page 80).
3. Connect the purge gas supply to the vent port adaptor.

Electrical installation of the nEXT85

The electrical installation must be carried out by a suitably qualified person. Always make the electrical connections to the pump after the pump has been installed on the vacuum system.

Do not remove the motor controller from the pump. There are no user-serviceable parts.



WARNING:

The pump must be electrically installed in accordance with regional and local codes, conforming to local and national safety requirements. It must be connected to an appropriately pre-approved power supply unit with a suitable earth (ground) point.

The nEXT85 pump can be operated using the Edwards TIC Turbo Instrument Controller, TIC Turbo Controller or TAG Controller. The nEXT85 pump can also be powered by the customer supply and controlled using the customer system. Refer to [Connect the logic interface to control equipment](#) on page 27 for information about control and to [Connect the electrical supply](#) on page 27 for instructions on how to connect the electrical supply.

Earth (ground) connections

Edwards recommend fitting a separate earth (ground) conductor to earth the nEXT85 pump.

Earth the pump using the connection provided. Refer to [Figure 11](#) on page 86, [Figure 12](#) on page 87, [Figure 13](#) on page 87 and [Figure 14](#) on page 87.

Use an uninsulated braid or a separate insulated green/yellow connector and use an M5 x 10 screw and shake-proof washer supplied (fitted to the earth hole on the pump) to secure the earth connector to the pump. The size/rating of this grounding conductor should be large enough to protect against other equipment within the customer system. The impedance between the pump body and the earth connection point must be $< 0.1\Omega$.

TIC or TAG logic interface connections

If an Edwards TIC Turbo Instrument Controller, TIC Turbo Controller or TAG Controller are used to power and control the pump, the nEXT85 pump logic interface cable connects directly into the back of the TIC or TAG. Refer to the TIC or TAG Instruction Manuals for further information.

The RS485/RS232 slide switch must be in the RS232 position if either the TIC or TAG is to be used to control the nEXT85 pump. Refer to [Connect the serial interface to the customer control equipment](#) on page 30. If the switch is in the RS485 position, the TIC will connect to the pump in parallel mode, indicating the pump type as nEXTp; the serial connection will be disabled, but start and stop will be possible. If the switch is in the RS485 position, the TAG will not connect to or control the pump at all.

Connect the logic interface to control equipment

To operate the nEXT85 pump using the customer's own control system, use a suitable connector mating half (not supplied) to connect the control equipment to the connector on the logic interface cable.

Refer to [Table 48](#) on page 96. When making the electrical connections to the nEXT85 pump, refer to [Table 49](#) on page 97 for full details of the logic interface connector pins.

Connect the electrical supply



WARNING:

This product requires a separate power supply (not included). The power supply should be adequately protected against a hazardous live condition (for example, in case of a short circuit).



WARNING:

Incorporate a suitable Emergency Stop Switch in the electrical supply. Locate the switch in an easily accessible position and mark it as the emergency disconnecting device for the pump. Failure to do so will result in not being able to switch off the pump in an emergency.



WARNING:

Incorporate a suitable fuse or current limiting device in the 24 - 48 V d.c. supply line to the pump. If this is not done and a fault develops, the pump may develop a hazardous surface temperature or present a fire hazard.

Refer to [Table 48](#) on page 96 for suitable fuse ratings.



WARNING:

Do not exceed the maximum supply voltage. Excessive supply voltage will cause permanent damage to the control electronics and may result in a mechanical hazard in some failure conditions.



WARNING:

When connecting the pump to the power supply, ensure that all 3 pins for the 24 - 48 V connection and all 3 pins for the 0 V connection on the customer connector mating half are connected to the power supply. Failure to utilise all of the power pins can lead to overheating of the connectors.

The electrical supply provided for the nEXT85 pump must meet the requirements of UL61010-1 and EN61010-1. Ensure that hazardous voltages as defined in UL61010-1 and EN61010-1 cannot be present on the electrical interface to the nEXT85 pump.

The nEXT85 pump 0 V is not referenced to earth (ground). Ensure that there is only one path between 0 V and earth. Multiple connections between 0V and earth must be avoided in order to avoid unexpected offset voltages on control and status signals and possible problems with serial communications. If no other connection is present between 0 V and earth, the connection should be made at the power supply. Be aware that other electrical equipment connected to the system could introduce a connection between 0 V and earth, for example a personal computer or measuring equipment.

Connect the parallel control and monitoring

Connections for parallel control and monitoring must be made using a suitable mating half that is not supplied.



CAUTION:

If using the normal and fail lines to drive the coils of d.c. relays, include a back EMF suppression diode in parallel with each relay coil to protect the pump.

1. Connect the customer control equipment to the control input pins of the customer logic interface mating half. Refer to [Table 49](#) on page 97, which identifies the logic interface connector pins.

The control inputs are Start and Standby speed. To activate either of these control inputs, connect the control input pin to the 0 V control reference. To start the pump, connect pin 3 (Start / Stop) to pin 2 (0 V Reference). To stop the pump, break the connection between pin 3 and pin 2. To put the pump into standby, connect both pin 4 (Standby) and pin 3 (Start/Stop) to pin 2 (0 V reference).

 **Note:**

Serial enable is also a control input but is not required in a system operating purely under parallel control. Make sure that there is no connection to serial enable (pin 5).

Note:

The RS485/RS232 slide switch must be in the (default) RS232 position to use the standby or fail parallel interface signals, refer to [Connect the serial interface to the customer control equipment](#) on page 30.

2. To monitor analogue output, connect the customer control equipment to the pump analogue output (pin 9) and to pin 2 of the customer logic interface mating half. When the pump is shipped, the analogue output is configured to monitor pump rotational speed. To monitor other parameters, re-configure the nEXT85 pump using commands over the Serial Interface. Refer to [Connection for serial control and monitoring](#) on page 29 for further details.
3. To monitor the normal status output, connect the customer control equipment to the normal status output (pin 15) and to pin 2 of the customer logic interface mating half. The output can be used to control other devices in the pumping system. The output can drive a low power relay of up to 24 V d.c. coil rating (up to 20 mA).
4. To monitor the fail status output, connect the customer control equipment to the fail output (pin 7) and to pin 2 of the customer logic interface mating half. The output can be used to control other devices in the pumping system. The output can drive a low power relay of up to 24 V d.c. coil rating (up to 20 mA).

Figure 3 Logic interface connections - parallel control

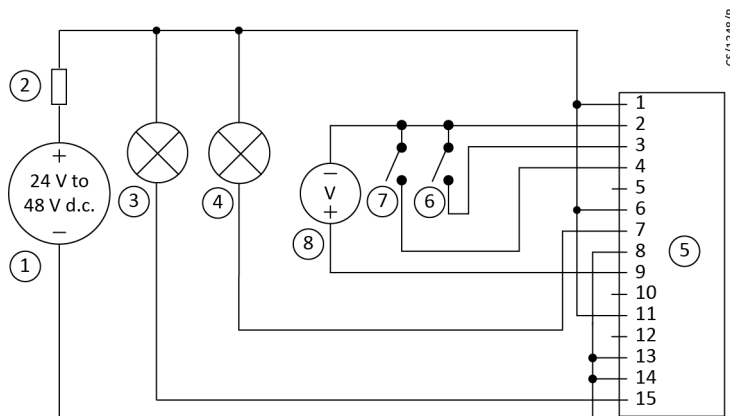

- | | |
|--------------------------------------|--|
| 1. 24 - 48 V d.c. electrical supply | 5. nEXT pump logic interface |
| 2. Fuse | 6. Start switch |
| 3. Optional indicator - normal speed | 7. Optional standby switch |
| 4. Optional indicator - system OK | 8. Optional voltmeter to monitor analogue output |

Connection for serial control and monitoring

The serial interface allows the nEXT85 pump to be controlled and to be interrogated as to its operational status using a number of serial commands or the nST PC software. There is also a multi-drop mode that allows for the connection of more than one nEXT85 pump to a single serial port on the control system.

Connect the serial interface to the customer control equipment

The serial interface is available in RS485 or RS232 options which can be selected using the slide switch located adjacent to the main power lead.

Refer to [Figure 4](#) on page 31. To adjust the slide switch, toggle the slide switch using a small tool. The motor controller default setting is RS232 serial interface. Be sure to replace the round seal in order to ensure the IP rating of the pump is still achieved.



CAUTION:

When connecting the pump to a PC, note that the 0 V pin on the RS232 connector may be connected to earth through the PC. If this is the case, ensure that the 0 V rail of the 24 - 48 V d.c. supply is not also connected to earth at some other point such as at the power supply. If the 0 V rail of the 24 - 48 V d.c. supply will not be connected to earth at the PC, an opto-isolated interface to the PC should be used.

The nEXT85 pump can connect directly to the RS485 or RS232 serial input on the control equipment or a PC as shown in [Figure 5](#) on page 31 and [Figure 6](#) on page 32. In this configuration the PC is the serial link master and the nEXT85 pump is the slave. The distance over which the serial link will work is dependent on any difference in voltage between the 0 V at the sending and receiving end. If the 0 V reference at the receiving end is within 0.3 V of the 0 V Control Reference pin on the nEXT85 pump control connector then the serial link should be capable of operating at distances up to 6 m. An interface circuit external to the nEXT85 pump may be required for longer distances.

The software in the nEXT85 pump is capable of operating with several pumps connected to a single serial link master. This is referred to as multi-drop mode. The RS485 option is recommended for multi-drop mode. With the RS232 option selected, some additional hardware will be required to link several nEXT85 pump units to a single serial link master. A concept drawing of one possible arrangement is shown in [Figure 21](#) on page 104. Conversely when the RS485 option is selected, connecting several nEXT85 pumps to a single master becomes a simple wiring exercise as shown in [Figure 22](#) on page 105.

Figure 4 Motor controller status information

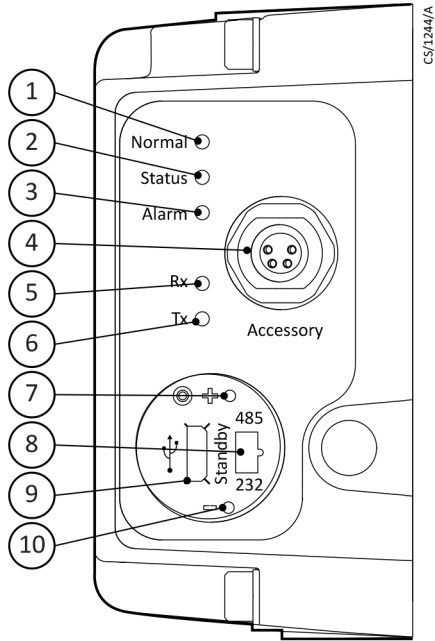

- | | |
|------------------------|-----------------------------------|
| 1. Normal LED | 6. Serial transmit LED |
| 2. Status LED | 7. Standby speed increase button |
| 3. Alarm LED | 8. RS232/RS485 slide switch |
| 4. Accessory connector | 9. USB connector |
| 5. Serial receive LED | 10. Standby speed decrease button |

Figure 5 Logic interface connections - RS232 serial control

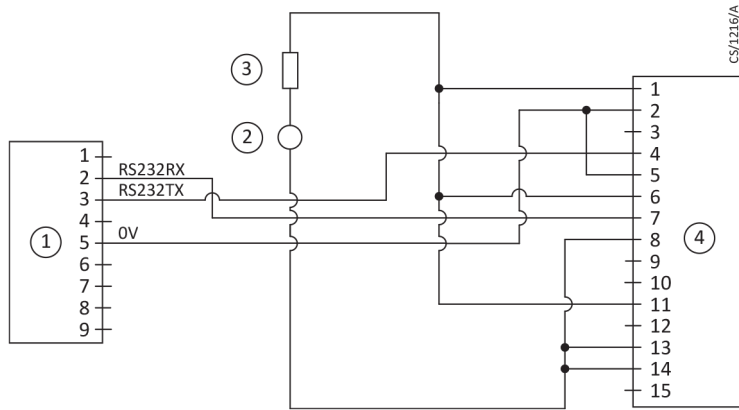

- | | |
|---|------------------------------|
| 1. RS232 interface on control equipment | 3. Fuse |
| 2. 24-48 V d.c. electrical supply | 4. nEXT pump logic interface |

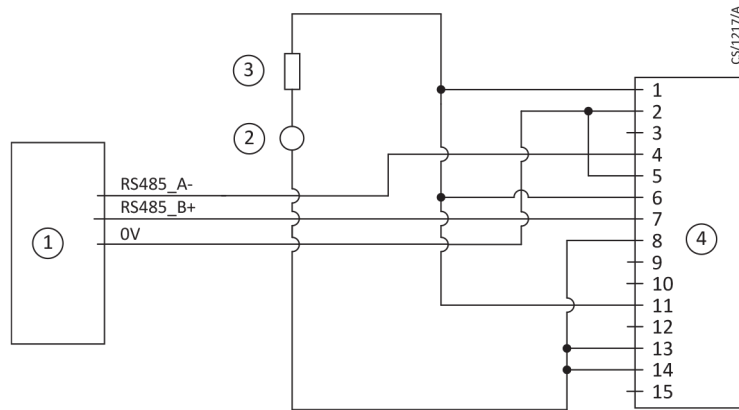
Figure 6 Logic interface connections - RS485 serial control

- | | |
|---|------------------------------|
| 1. RS485 interface on control equipment | 3. Fuse |
| 2. 24-48 V d.c. electrical supply | 4. nEXT pump logic interface |

Serial enable

To send a serial message over the serial link, serial enable must first be activated.

Link the serial enable input signal (pin 5) to pin 2 of the customer logic interface mating half.

Edwards recommends incorporating this link into the serial communications cable so that the serial enable is only activated when the serial cable is connected. When the cable is removed, serial enable will become inactive.

Serial enable acts as an interlock for start commands sent over the serial interface. If the pump is running in serial control mode (having been sent a serial start command) and the serial enable subsequently becomes inactive, the pump will trigger a fail condition and will decelerate to rest. To clear this fail condition, re-activate the serial enable and send a serial stop command.

Connection for mixed parallel and serial operation

The pump can be controlled using parallel interface control inputs and at the same time monitor various pump parameters using the serial interface or the USB service port using the Edwards nST PC software. Alternatively, the pump can be controlled using commands sent over the serial interface while at the same time monitor the normal signal and analogue output over the parallel interface.

[Figure 7](#) on page 33 shows a schematic diagram of a system that demonstrates how to do this. This connection is a hybrid of the parallel and serial connection which are described in detail in [Connect the parallel control and monitoring](#) on page 28 and [Connection for serial control and monitoring](#) on page 29 respectively. Many of the options described in those sections are available in mixed parallel and serial operation but note that whilst serial enable is active to enable the serial link, the parallel standby and fail signals are not available. The multi-drop connection shown in [Figure 7](#) on page 33 can also be used with mixed parallel and serial operation.

The pump cannot be controlled using both the parallel and serial interfaces simultaneously. For example, if the pump is started by sending a start command over the serial interface, the pump cannot then be stopped by using the start /stop switch on the parallel interface. The pump will ignore the state of the start / stop switch on the parallel interface. To stop the pump, send a serial stop command. Only when the serial stop command has been received by the pump can any commands sent via the parallel interface be acted on.

Similarly, if the pump is started by using the start switch on the parallel interface, the pump cannot then be stopped by sending a stop command over the serial interface. The pump will ignore any start or stop commands received over the serial interface. To stop the pump, use the parallel stop switch. Only when the pump has been stopped using the parallel interface switch will any start or stop commands be accepted via the serial interface.

Figure 7 Logic interface connection - mixed parallel and serial operation

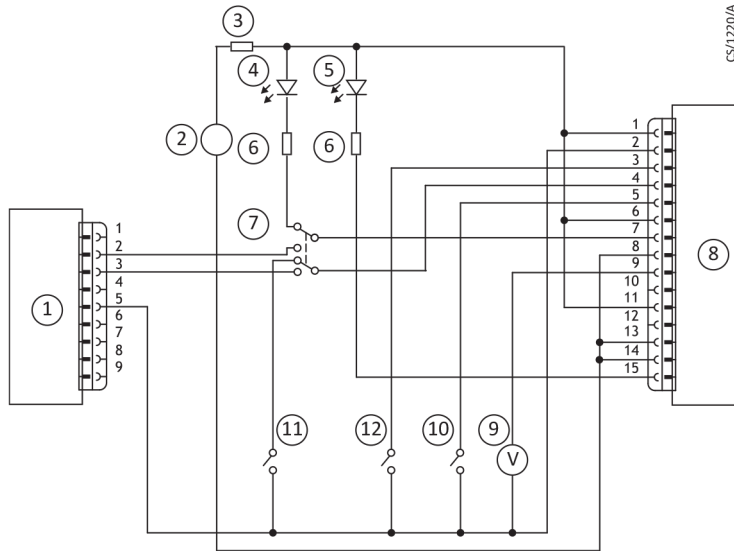

- | | |
|--|-----------------------------------|
| 1. RS232 interface on control equipment | 7. Optional serial link selector |
| 2. 24 V d.c. electrical supply | 8. nEXT pump |
| 3. Fuse | 9. Optional voltmeter |
| 4. Optional LED indicator - system OK | 10. Optional serial enable switch |
| 5. Optional LED indicator - normal speed | 11. Optional standby switch |
| 6. Current limit resistor for LED | 12. Start switch |

Cooling

Cooling requirements



CAUTION:

Ensure that the pump is adequately cooled to prevent damage to the rotor and bearing.



CAUTION:

When using alternative cooling arrangements other than the standard Edwards cooling accessories, ensure cooling is not solely directed or ducted onto the pump controller.



CAUTION:

If the pump will be located inside an enclosure, ensure that there is adequate ventilation so that the ambient temperature around the pump does not exceed 40 °C.

Note:

During operation, if the temperature of any surface of the pump is higher than 60 °C, the cooling is inadequate and should be increased. Pump performance may be affected if you do not cool the pump and nEXT85 motor controller adequately.

Edwards recommends that, wherever possible, the pump is cooled by forced air cooling or water cooling.

Select the cooling type required according to the ambient temperature:

- Natural convection cooling: For some light pumping duties, with an ambient air temperature less than 35 °C, natural convection cooling may be adequate to cool the nEXT85 pump.
- Forced air cooling: The ambient air temperature must be 5 °C to 40 °C when using forced air cooling. Ensure that there is an adequate supply of cooling air to the pump.
- Water cooling: Use water cooling with higher load applications or when using a flange heater (CF variants only). When using water cooling, ambient air temperature must be less than 40 °C and the water temperature must be between 10 °C and 40 °C.

Refer to [Pump performance data](#) on page 88 for further performance information.

Forced air cooling

The customer controller can be configured to drive an air cooler only if commands can be sent via the serial interface or an Edwards TIC Turbo and Instrument Controller or Turbo Controller.

Air cooling accessories are available for nEXT85 pumps (refer to [Accessories for the nEXT85](#) on page 80). Fit the air cooler as described in the instruction manual supplied with it. If an alternative fan is used for air cooling, ensure that the flow rate is above 100 m³h⁻¹ (60 cfm).

The air cooler can be powered by a customer external power supply, the Edwards TIC Turbo and Instrument Controller, the TIC Turbo Controller or the nEXT85 Controller. Plug the connector into the socket at the side of the controller (refer to [Figure 8](#) on page 50).

Water cooling

An accessory is available to enable the pump to be water cooled. Fit the water cooler as described in the instructions supplied with it.

Ensure that the water supply is constant and within the quality, temperature and flow rate limits specified in [Table 2](#) on page 35.



CAUTION:

In the event of coolant failure, the pump must be allowed to cool down to ambient temperature before restarting.



CAUTION:

Condensation may occur if a water cooling block is used in high humidity environments. Protect the pump and other equipment by considering the design of the installation.

Pipes in the water cooling circuit may become blocked if the cooling water contains too much calcium carbonate or if it contains particles that are too large. Corrosion of the water cooling circuit may occur if there is too little calcium carbonate and oxygen in the water. Good quality drinking water is usually suitable. If in doubt, check the quality of the cooling water supply and, if necessary, provide treatment and filtration.

1. Connect the cooling water supply to the water cooler on the pump as described below. Either of the two push fit connectors on the water cooler can be used for the water supply or return connections.
2. Push nylon hose (approximately 10 mm outer diameter) into the ends of the hose connectors on the water cooler on the pump. Alternatively, remove the hose connectors from the water cooler and make direct connections to the 1/8 inch BSP female threaded fittings on the water cooler.
3. To avoid breaking the cooling water circuit when removing the pump for maintenance, unscrew the two M6 fixing screws and remove the water cooler from the pump.

Table 2 Water cooling block supply requirements

Parameter	Specification
Quality	Mechanically and optically clean with no deposits or turbidity
pH Value	6.0 to 8.0
Maximum calcium carbonate concentration	75 parts per million
Maximum chloride concentration	100 parts per million
Minimum oxygen concentration	4 parts per million
Minimum water-cooling flow rate (at 15 °C)	15 l h ⁻¹
Water temperature range	10 °C to 40 °C
Maximum water pressure	5 bar (gauge), 72.5 psig, 5 x 10 ⁵ Pa gauge
Materials exposed to cooling water	Nickel plated brass

Configuration

Before operating the pump configure the motor controller settings so that they are suitable for the application.

If the system is designed to operate with parallel control and monitoring, there is no facility to change the majority of the motor controller settings once the pump is installed on the system. The pump is supplied with all settings at factory default values, as shown in [Table 50](#) on page 99. If any of the motor controller settings are to be changed, change them before installing the pump on the system.

The pump can be configured using the customer serial comms over the serial interface. [Configure the pump using serial commands](#) on page 36 details the commands that will be needed to configure the motor controller. Alternatively, use the Edwards TIC Turbo and Instrument Controller, TIC Turbo Controller or TAG Controller. Further information regarding this is detailed in [Configure the pump using a TIC](#) on page 44. The Edwards nST PC software can also be used to configure the pump, either via the serial interface or via the USB service port.

 **Note:**

The standby speed may be adjusted using the button on the motor controller as described in [Standby speed setting](#) on page 40.

If the pump is operated with parallel control and monitoring and the controller settings will not be reconfigured, go straight to [Before starting the pump](#) on page 46.

Configure the pump using serial commands

Refer to [Table 50](#) on page 99 for a summary of the full set of serial commands, parameter ranges and factory defaults for each setting.

Message structure	The message structure and command set are the same for RS485 and RS232 options. To communicate a message to the nEXT85 pump, the characters must be sent in a specific order. If the message does not conform to the correct structure it will be ignored and no reply will be sent.
Command and reply table definitions	Explanation of the command and reply characters.
Power limit setting	The pump is supplied with a default power limit. If this limit is not suitable for the application, change it to any value between the maximum and minimum setting.
Powering a fan from the motor controller	A fan can be powered from the nEXT85 motor controller on auxiliary output 2.
Controlled venting options	If the motor controller is used to automatically control a vent valve, there are a number of venting options available.
Standby speed setting	The pump can be run at standby speed rather than full rotational speed. The standby speed is a user-configurable option and can be set to any value between 55% and 100% full rotational speed.
Normal speed setting	The normal speed is a user-configurable setting and can be set to any value between 50% and 100% full rotational speed.

Timer setting and options	The timeout period is a user-configurable option and can be set to any value from 1 to 30 minutes.
Analogue signal options	The analogue output can be used to monitor one of five different parameters.
Electronic braking options	The pump is supplied with the electronic braking disabled by default.
Factory settings	The nEXT85 pump can be re-configured to its original factory settings with one serial command.
Assigning a multi-drop address	Each individual pump must be programmed with its own multi-drop address via a point-to-point connection before introduction into a multi-drop network.

Message structure

The message structure and command set are the same for RS485 and RS232 options. To communicate a message to the nEXT85 pump, the characters must be sent in a specific order. If the message does not conform to the correct structure it will be ignored and no reply will be sent.

The correct structure to use is as follows:

- a valid start character, either a '!' character for a store operation or a '?' character for a query operation, followed by
- a command, which will be an upper case alphabetical character, followed by
- an object number, comprising three decimal digits, followed by
- for some commands only, a data field, comprising a sequence of characters separated from the object number by a space, followed by
- a terminating carriage return

The message protocol in multi-drop mode is marginally different, refer to [Multi-drop operation](#) on page 103.

Command and reply table definitions

Explanation of the command and reply characters.

Table 3 Command abbreviations

Abbreviation	Meaning
cr	Carriage return character
chars	Characters
d	Decimal ASCII character *
h	Hexadecimal ASCII character
r	Returned error code - refer to Command set error codes on page 70
sp	Space character
string	May have several ASCII characters
X	Multi-drop decimal ASCII character §

* Fields showing multiple d characters are to indicate typical length. All data fields have a maximum of 5 decimal characters (prefixed by a minus number for negative numbers).

§ Fields showing multiple X characters are to indicate maximum length and not fixed length.

Typical setting command:

Command	!	S	8	5	5	sp	d	d	d	cr												
---------	---	---	---	---	---	----	---	---	---	----	--	--	--	--	--	--	--	--	--	--	--	--

Typical setting reply:

Reply	*	S	8	5	5	sp	r	cr														
-------	---	---	---	---	---	----	---	----	--	--	--	--	--	--	--	--	--	--	--	--	--	--

Typical query command:

Command	?	S	8	5	5	cr																
---------	---	---	---	---	---	----	--	--	--	--	--	--	--	--	--	--	--	--	--	--	--	--

Typical query reply:

Reply	=	S	8	5	5	sp	d	d	d	cr												
-------	---	---	---	---	---	----	---	---	---	----	--	--	--	--	--	--	--	--	--	--	--	--

Power limit setting

The pump is supplied with a default power limit. If this limit is not suitable for the application, change it to any value between the maximum and minimum setting.

Table 4 Power limit setting

Maximum value setting	Minimum value setting	Default power setting
120 W	50 W	80 W

Send the command as follows (where the 'd' characters represent the value in Watts that will be set. For example, to set the limit to 90 W, type 90).

Command	!	S	8	5	5	sp	d	d	d	cr												
---------	---	---	---	---	---	----	---	---	---	----	--	--	--	--	--	--	--	--	--	--	--	--

The reply will be in the following format:

Reply	*	S	8	5	5	sp	r	cr														
-------	---	---	---	---	---	----	---	----	--	--	--	--	--	--	--	--	--	--	--	--	--	--

The power limit setting is now stored in memory within the nEXT85 pump. To check what power limit is set, send a query as follows:

Command	?	S	8	5	5	cr																
---------	---	---	---	---	---	----	--	--	--	--	--	--	--	--	--	--	--	--	--	--	--	--

The reply will be in the following format:

Reply	=	S	8	5	5	sp	d	d	d	cr												
-------	---	---	---	---	---	----	---	---	---	----	--	--	--	--	--	--	--	--	--	--	--	--

Powering a fan from the motor controller

A fan can be powered from the nEXT85 motor controller on auxiliary output 2.

Send the following command:

Command	!	S	8	6	4	sp	8	cr														
---------	---	---	---	---	---	----	---	----	--	--	--	--	--	--	--	--	--	--	--	--	--	--

The reply will be in the following format:

Reply	*	S	8	6	4	sp	r	cr											
-------	---	---	---	---	---	----	---	----	--	--	--	--	--	--	--	--	--	--	--

The permanently enabled fan setting is now stored in memory within the nEXT85 pump.

When the pump is shipped, it is set up to run a vent valve. Send a query to find out what the setting is as follows:

Command	?	S	8	6	4	cr													
---------	---	---	---	---	---	----	--	--	--	--	--	--	--	--	--	--	--	--	--

The reply will be in the following format:

Reply	*	S	8	6	4	sp	d	cr											
-------	---	---	---	---	---	----	---	----	--	--	--	--	--	--	--	--	--	--	--

If the character 'd' is 8, then the fan is enabled. If it is anything else, configure the motor controller to run the fan.

Controlled venting options

If the motor controller is used to automatically control a vent valve, there are a number of venting options available.

Refer to [Table 6](#) on page 48 for available venting options and refer to [Table 7](#) on page 49 for available valve types.

To set a vent option on auxiliary output 1, send the following command, (where the character 'd' refers to the option number shown in [Table 6](#) on page 48):

Command	!	S	8	5	3	sp	d	cr											
---------	---	---	---	---	---	----	---	----	--	--	--	--	--	--	--	--	--	--	--

The reply will be in the following format:

Reply	*	S	8	5	3	sp	r	cr											
-------	---	---	---	---	---	----	---	----	--	--	--	--	--	--	--	--	--	--	--

The venting option is now stored in memory within the nEXT85 pump.

To check the venting option that is set, send a query as follows:

Command	?	S	8	5	3	cr													
---------	---	---	---	---	---	----	--	--	--	--	--	--	--	--	--	--	--	--	--

The reply will be in the following format:

Reply	=	S	8	5	3	sp	d	cr											
-------	---	---	---	---	---	----	---	----	--	--	--	--	--	--	--	--	--	--	--

To set the valve type on auxiliary output 1, send the following command, (where the character 'd' refers to the option number shown in [Table 7](#) on page 49):

Command	!	S	8	7	7	sp	d	cr											
---------	---	---	---	---	---	----	---	----	--	--	--	--	--	--	--	--	--	--	--

The reply will be in the following format:

Reply	*	S	8	7	7	sp	r	cr											
-------	---	---	---	---	---	----	---	----	--	--	--	--	--	--	--	--	--	--	--

The valve type is now stored in memory within the nEXT85 pump, but a power cycle is required before the auxiliary 1 output circuitry adjusts to the stored request.

To check the venting option that is set, send a query as follows:

Command	?	S	8	7	7	cr													
---------	---	---	---	---	---	----	--	--	--	--	--	--	--	--	--	--	--	--	--

The reply will be in the following format:

Reply	=	S	8	7	7	sp	d	cr											
-------	---	---	---	---	---	----	---	----	--	--	--	--	--	--	--	--	--	--	--

Standby speed setting

The pump can be run at standby speed rather than full rotational speed. The standby speed is a user-configurable option and can be set to any value between 55% and 100% full rotational speed.

When the pump is shipped, it is configured with a standby speed of 70% full rotational speed.

The standby speed setting can be changed using the STDBY+ and STDBY- push buttons located on the motor controller (shown in [Figure 4](#) on page 31) or by using a serial command. If using the buttons, each button press will adjust the speed by 15 Hz (1%).

To change the standby speed setting using a serial command, send the following command (where the characters 'd' represent the value as a percentage of full rotational speed):

Command	!	S	8	5	7	sp	d	d	d	cr									
---------	---	---	---	---	---	----	---	---	---	----	--	--	--	--	--	--	--	--	--

The reply will be in the following format:

Reply	*	S	8	5	7	sp	r	cr											
-------	---	---	---	---	---	----	---	----	--	--	--	--	--	--	--	--	--	--	--

The standby speed is now stored in memory within the nEXT85 pump.

To check what standby speed is set, send a query as follows:

Command	?	S	8	5	7	cr													
---------	---	---	---	---	---	----	--	--	--	--	--	--	--	--	--	--	--	--	--

The reply will be as follows:

Reply	=	S	8	5	7	sp	d	d	d	cr									
-------	---	---	---	---	---	----	---	---	---	----	--	--	--	--	--	--	--	--	--

Normal speed setting

The normal speed is a user-configurable setting and can be set to any value between 50% and 100% full rotational speed.

When the pump is shipped, it is configured with a normal speed of 80% full rotational speed.

To change the normal speed setting, send the following command (where the characters 'd' represent the value as a percentage of full rotational speed):

Command	!	S	8	5	6	sp	d	d	d	cr									
---------	---	---	---	---	---	----	---	---	---	----	--	--	--	--	--	--	--	--	--

The reply will be in the following format:

Reply	*	S	8	5	6	sp	r	cr											
-------	---	---	---	---	---	----	---	----	--	--	--	--	--	--	--	--	--	--	--

The normal speed is now stored in memory within the nEXT85 pump.

To check what normal speed is set, send a query as follows:

Command	?	S	8	5	6	cr													
---------	---	---	---	---	---	----	--	--	--	--	--	--	--	--	--	--	--	--	--

The reply will be as follows:

Reply	=	S	8	5	6	sp	d	d	d	cr									
-------	---	---	---	---	---	----	---	---	---	----	--	--	--	--	--	--	--	--	--

Timer setting and options

The timeout period is a user-configurable option and can be set to any value from 1 to 30 minutes.

When the pump is shipped, it is configured with a default timeout period of 8 minutes.

Refer to [Timer](#) on page 15 for a full description of timer functionality.

To change the timer setting, send the following command (where the characters 'd' represent the timeout period in minutes):

Command	!	S	8	5	4	sp	d	d	cr										
---------	---	---	---	---	---	----	---	---	----	--	--	--	--	--	--	--	--	--	--

The reply will be in the following format:

Reply	*	S	8	5	4	sp	r	cr											
-------	---	---	---	---	---	----	---	----	--	--	--	--	--	--	--	--	--	--	--

The timer setting is now stored in memory within the nEXT85 pump.

To check what timeout period is set, send a query as follows:

Command	?	S	8	5	4	cr													
---------	---	---	---	---	---	----	--	--	--	--	--	--	--	--	--	--	--	--	--

The reply will be as follows:

Reply	=	S	8	5	4	sp	d	d	cr										
-------	---	---	---	---	---	----	---	---	----	--	--	--	--	--	--	--	--	--	--

The timer is permanently enabled during ramp-up, however it is optional to have it enabled at other times. When the pump is shipped, the timer is enabled by default.

To disable the timer, send the following serial command:

Command	!	S	8	7	0	sp	0	cr											
---------	---	---	---	---	---	----	---	----	--	--	--	--	--	--	--	--	--	--	--

The reply will be in the following format:

Reply	*	S	8	7	0	sp	r	cr											
-------	---	---	---	---	---	----	---	----	--	--	--	--	--	--	--	--	--	--	--

The state of the timer option is stored in memory within the nEXT85 pump.

To enable the timer again, send the following serial command:

Command	!	S	8	7	0	sp	1	cr											
---------	---	---	---	---	---	----	---	----	--	--	--	--	--	--	--	--	--	--	--

The reply will be as follows:

Reply	*	S	8	7	0	sp	r	cr											
-------	---	---	---	---	---	----	---	----	--	--	--	--	--	--	--	--	--	--	--

To check whether the timer is enabled or disabled, send the following query:

Command	?	S	8	7	0	cr															
---------	---	---	---	---	---	----	--	--	--	--	--	--	--	--	--	--	--	--	--	--	--

The reply will be as follows (where d=0 means disabled and d=1 means enabled):

Reply	=	S	8	7	0	sp	d	cr													
-------	---	---	---	---	---	----	---	----	--	--	--	--	--	--	--	--	--	--	--	--	--

Analogue signal options

The analogue output can be used to monitor one of five different parameters.

Table 5 Analogue signal options

Option number	Description of analogue output number
0	Measured pump rotational speed *
1	Measured link power
2	Measured motor temperature
3	Measured motor controller temperature
4	Measured rotor temperature

* This is the factory default setting.

To configure the analogue output, send the following command (where the character 'd' denotes the option number detailed in [Table 5](#) on page 42).

Command	!	S	8	7	1	sp	d	cr													
---------	---	---	---	---	---	----	---	----	--	--	--	--	--	--	--	--	--	--	--	--	--

The reply will be in the following format:

Reply	*	S	8	7	1	sp	d	cr													
-------	---	---	---	---	---	----	---	----	--	--	--	--	--	--	--	--	--	--	--	--	--

The analogue output signal setting is now stored in memory within the nEXT85 pump.

To check which analogue output signal and setting is enabled, send a query as follows:

Command	?	S	8	7	1	cr															
---------	---	---	---	---	---	----	--	--	--	--	--	--	--	--	--	--	--	--	--	--	--

The reply will be as follows:

Reply	=	S	8	7	1	sp	d	cr													
-------	---	---	---	---	---	----	---	----	--	--	--	--	--	--	--	--	--	--	--	--	--

Electronic braking options

The pump is supplied with the electronic braking disabled by default.

Refer to [Electronic braking](#) on page 17 for a full description of the electronic braking feature. To enable electronic braking, send the following serial command:

Command	!	S	8	7	2	sp	1	cr													
---------	---	---	---	---	---	----	---	----	--	--	--	--	--	--	--	--	--	--	--	--	--

The reply will be in the following format:

Reply	*	S	8	7	2	sp	r	cr													
-------	---	---	---	---	---	----	---	----	--	--	--	--	--	--	--	--	--	--	--	--	--

The state of the electronic braking option is stored in memory within the nEXT85 pump.

To disable the electronic braking again, send the following serial command:

Command	!	S	8	7	2	sp	0	cr												
---------	---	---	---	---	---	----	---	----	--	--	--	--	--	--	--	--	--	--	--	--

The reply will be as follows:

Reply	*	S	8	7	2	sp	r	cr												
-------	---	---	---	---	---	----	---	----	--	--	--	--	--	--	--	--	--	--	--	--

To check whether electronic braking is enable or disable, send the following query:

Command	?	S	8	7	2	cr														
---------	---	---	---	---	---	----	--	--	--	--	--	--	--	--	--	--	--	--	--	--

The reply will be as follows (where d=0 means disabled and d=1 means enabled):

Reply	=	S	8	7	2	sp	d	cr												
-------	---	---	---	---	---	----	---	----	--	--	--	--	--	--	--	--	--	--	--	--

Factory settings

The nEXT85 pump can be re-configured to its original factory settings with one serial command.

To reset the motor controller to factory settings, send the following command:

Command	!	S	8	6	7	sp	1	cr												
---------	---	---	---	---	---	----	---	----	--	--	--	--	--	--	--	--	--	--	--	--

The reply will be in the following format:

Reply	*	S	8	6	7	sp	r	cr												
-------	---	---	---	---	---	----	---	----	--	--	--	--	--	--	--	--	--	--	--	--

The factory settings are restored in the memory within the nEXT85 pump. A Power cycle may be required if either valve type setting was previously configured to a non-default setting.

Assigning a multi-drop address

Each individual pump must be programmed with its own multi-drop address via a point-to-point connection before introduction into a multi-drop network.

When the nEXT85 pump is shipped, multi-drop mode is disabled by default.

Send the following command to assign a multi-drop address (where the 'd' characters represent the address):

Command	!	S	8	5	0	sp	d	d	cr											
---------	---	---	---	---	---	----	---	---	----	--	--	--	--	--	--	--	--	--	--	--

Note:

The address can be any decimal number from 1 to 98. The address number 0 is used to disable multi-drop mode. The address number 99 is reserved as a wild card and is used in the query set up detailed later.

The reply will be in the following format:

Reply	*	S	8	5	0	sp	r	cr												
-------	---	---	---	---	---	----	---	----	--	--	--	--	--	--	--	--	--	--	--	--

The multi-drop address is stored within the nEXT85 pump.

A query can be sent to the pump to find out if it has a multi-drop address. Send the following command:

Command	?	S	8	5	0	cr														
---------	---	---	---	---	---	----	--	--	--	--	--	--	--	--	--	--	--	--	--	--

If the reply is as shown below, the pump has multi-drop mode disabled:

Reply	=	S	8	5	0	sp	0	cr												
-------	---	---	---	---	---	----	---	----	--	--	--	--	--	--	--	--	--	--	--	--

If the pump already has a multi-drop address, there will be no reply. Communicate with the pump in multi-drop message protocol. Refer to [Multi-drop operation](#) on page 103 for more information about multi-drop mode and multi-drop message protocol.

Use the following query (using wild card address 99 which means 'any' node) to find out the multi-drop address of the nEXT85 pump:

Command	#	9	9	:	9	9	?	5	8	5	0	cr								
---------	---	---	---	---	---	---	---	---	---	---	---	----	--	--	--	--	--	--	--	--

The reply will be as follows, where dd denotes the multi-drop address of the pump:

Reply	#	9	9	:	9	9	=	S	8	5	0	sp	d	d	cr					
-------	---	---	---	---	---	---	---	---	---	---	---	----	---	---	----	--	--	--	--	--

Multi-drop mode can be disabled by assigning the pump an address 0. To do this, send the following command (where dd denotes the multi-drop address of the pump and XX denotes the address of the node that is sending the command):

Command	#	d	d	:	x	x	1	S	8	5	0	sp	0	cr						
---------	---	---	---	---	---	---	---	---	---	---	---	----	---	----	--	--	--	--	--	--

The reply will be in the following format:

Reply	#	x	x	:	d	d	*	S	8	5	0	sp	0	cr						
-------	---	---	---	---	---	---	---	---	---	---	---	----	---	----	--	--	--	--	--	--

Once multi-drop mode is disabled, the pump will no longer respond to multi-drop commands.

Configure the pump using a TIC

The nEXT85 pump can be configured using the Edwards TIC Turbo and Instrument Controller or TIC Turbo Controller.

Refer to [TIC or TAG logic interface connections](#) on page 27.

It is possible to set the following parameters of the nEXT85 pump using the TIC:

- Power limit setting
- Vent options and vent type, including running a fan from the motor controller
- Standby speed setting
- Normal speed setting
- Timer settings - both enabling/disabling the timer AND setting the timeout period
- Electronic braking options
- Factory default settings

For information on how to perform these settings, refer to the TIC Turbo and Instrument controller or TIC Turbo Controller Instruction Manuals.

 **Note:**

It is not possible to configure the analogue output options using the TIC. There is also no facility within the TIC to assign a multi-drop address to the nEXT85 pump.

Operation of the nEXT85

Before starting the pump

Before starting the pump the vent valve must be closed and pre-start sequence completed.

Close the vent valve

The vent valve can be closed manually, by using the customer control system or by TAV5 solenoid valve.

1. If using a manual vent valve, turn it clockwise to close it.
2. If using the customer control system to drive a vent valve, make sure that the vent valve is closed.
3. If driving a TAV solenoid valve from the motor controller, the TAV valve will automatically shut when the pump is started.
4. If using the TIC to operate the vent valve, refer to [Operation with a TIC or TAG](#) on page 55.

Note:

The backing pump and nEXT85 pump can be started at the same time. The nEXT85 pump will not be damaged and can operate as an effective baffle, however, if the vacuum system is large (100 litres or larger) it will be more efficient to allow the backing pump to reduce system pressure to 10 mbar before starting the nEXT85 pump. In this case it will be necessary to close the vent valve in advance of starting the backing pump.

When using the motor controller to control a TAV solenoid valve and operating with parallel control and monitoring, the valve cannot be shut in advance of starting the nEXT85 pump because the facility to send the appropriate serial command is not available. If the facility to send serial commands is available, a delayed start can be performed. Refer to [Delayed start with serial control](#) on page 52 .

Pre-start sequence

Complete the pre-start sequence to check that the pump is ready for operation.

Note:

If the motor controller has been configured to drive a fan, the fan will automatically start when power is supplied to the nEXT85 pump.

1. Turn on the appropriate cooling device (fan or cooling water supply).
2. Start the backing pump.
3. Switch on the power supply to the pump. Check that the three normal, status and alarm LEDs on the motor controller light up for approximately 0.5 seconds and then extinguish.

If the LEDs do not light up as expected, or if the red or yellow LEDs begins to flash a repeated sequence or if the red LED is lit, refer to [Troubleshooting](#) on page 67.

Vent options, vent valve connection and control

Note:

If manually venting the pump when it is at full rotational speed and the subsequent rate of pressure rise is too high, the pump life may be reduced. When using the manual vent valve supplied, it is recommended to either limit the vent or only open the vent valve after the pump speed has fallen to 50% of full rotational speed. Do not vent from the backing line as this may lead to contamination. If venting into the vacuum system and using an oil sealed rotary backing pump, select a point upstream of the pump, to prevent oil back-streaming from the backing line. [Table 8](#) on page 50 gives an indication of the appropriate orifice size to be fitted to the vent-valve for given vacuum system volumes in order that the vent rate is kept within the limits given in [Venting gas specification and vent control data](#) on page 93.

To maintain the cleanliness of the vacuum system, venting the pump (or vacuum system) is recommended whenever switching the pump off.

Manual vent valve

Edwards recommends that the manual vent valve is opened only after the pump speed has fallen to 50% of full rotational speed.

A manual vent valve is supplied with the nEXT85 pump. It is not possible to accurately control the rate of pressure rise using the manual vent valve so take care not to open it too quickly.

TAV5 solenoid vent valve

The TAV5 solenoid valves can be purchased as accessories and come either pre-wired with an auxiliary connector fitted or as a bare-wire option.

Both 'Normally Closed' and 'Normally Open' valves are available, refer to [Accessories for the nEXT85](#) on page 80.

Venting may be accomplished by one of the following means, and by using the procedure below:

- Use the TAV5 solenoid vent valve in the manual vent valve position.
- Use the TAV5 solenoid vent valve connected to a convenient flange on the vacuum system.
- Use an alternative vent valve, with an appropriate restriction, connected to the vacuum system.

When using the TAV5 vent valve, the pump may only be hard vented when it is at full speed if the vacuum system has a volume of 5 litres or more.

If the volume of the vacuum system is less than 5 litres, incorporate a suitable vent restrictor and vent the pump when it is at full speed or else use the controlled venting option. [Table 8](#) on page 50 gives an indication of the appropriate orifice size to be fitted to the vent valve for given vacuum system volumes in order that the rate of pressure rise remains within the limits shown in [Venting gas specification and vent control data](#) on page 93.

Note:

If a vent restrictor is used, the time required to vent the vacuum system may be unacceptably long. The time may be reduced by using a vent valve without a vent restrictor and waiting until the pump speed has fallen to 50% of full rotational speed before opening the vent valve.

Vent valve control

The TAV5 solenoid valve can be controlled by the nEXT85 motor controller or by an Edwards TIC Turbo Instrument Controller.

The nEXT85 controller can control the rate of venting, using the vent valve options in [Table 6](#) on page 48. Using this feature the pump can be vented from full rotational speed in a controlled manner that will not damage the pump bearings. Once the pump rotational speed has dropped to below 50% of maximum speed, it is safe to hard vent (open the vent valve fully) provided the backing pump is left on and the backing valve is open.

To use the nEXT85 controller function, the nEXT85 turbo pump controller has a 4-pin auxiliary connector socket on the side of the pump, as circled in [Figure 8](#) on page 50, to which the vent valve with the auxiliary connector fitted is plugged into.

The controller is capable of controlling a number of different venting options. These are defined in [Table 6](#) on page 48.

The controller is capable of accommodating both normally open and normally closed vent valve types. These are defined in [Table 7](#) on page 49. A power cycle is required after making a change to the valve type, before the auxiliary output circuitry adjusts to accommodate the requested change.

Table 6 Vent valve options

Option number	Description of vent function
0	Vent valve opens fully below 50% full rotational speed for either a stop command or fail condition. *
1	Controlled venting from 100% to 50% full rotational speed and then vent valve opens fully below 50% for either a stop command or fail condition.
2	If a stop command is received, vent valve fully opens immediately. In a fail condition, vent valve opens fully below 50% full rotational speed.
3	If a stop command is received, vent valve fully opens immediately. In a fail condition, controlled venting from 100% to 50% full rotational speed and then vent valve opens fully below 50%.
4	In a fail condition, vent valve fully opens immediately. If a stop command is received, vent valve opens fully below 50% full rotational speed.
5	In a fail condition, vent valve fully opens immediately. If a stop command is received, controlled venting from 100% to 50% full rotational speed and then vent valve opens fully below 50%.
6	Vent valve fully opens immediately for either a stop command or a fail condition.
7	Same as option 6
8	Auxiliary output is permanently energised (Fan). §
9	Do not use
10	Auxiliary output is permanently de-energised (Fan).
11	Do not use
12	Do not use
13	Do not use

Option number	Description of vent function
14	Vent valve opens fully below 50% full rotational speed for a stop command.
15	Controlled venting from 100% to 50% full rotational speed and then vent valve opens fully below 50% for a stop command.

* This is the factory default setting for Vent Option 1.

§ This is the factory default setting for Vent Option 2 to enable cooling fan behaviour.

Table 7 Valve types

Option number	Description of valve type
0	Normally open vent valve *
1	Normally closed vent valve

* This is the factory default setting for Valve 1 type and Valve 2 type.

When the pump is shipped, the controller is configured with the factory default Vent option 1 set to 0 and the Valve 1 type set to 0, as detailed in [Table 6](#) on page 48 and [Table 7](#) on page 49. The controller can be configured to one of the other venting options provided commands can be sent via the serial interface or an Edwards TIC Turbo and Instrument Controller or TIC Turbo Controller or the Edwards nST PC software can be used via the USB serial port.

If the valve type is set to normally open, the controller only energises or shuts the TAV solenoid valve when it receives a start command. Prior to that, the valve will be in the 'open' vent state. If the vacuum system is a large system, allow the backing pump to reduce the pressure in the system to an acceptable level before starting the nEXT85 pump. In this case, send a command via the serial interface to close the vent valve before sending a start command – this is known as a delayed start.

If the valve type is set to normally closed, and either vent options 14 or 15 are used, the controller will ensure that the TAV solenoid valve will only ever 'open' upon receipt of a stop command. Therefore there is no need to send the delayed start command.

If the nEXT85 pump is being controlled with an Edwards TIC Turbo and Instrument Controller or TIC Turbo Controller, the TAV solenoid valve can be driven from the TIC. Refer to the TIC Instruction Manuals for more information.

Figure 8 Auxiliary interface connection

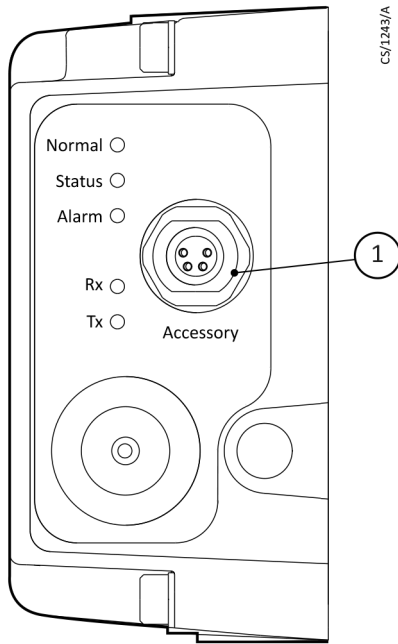

1. Accessory Connector

Alternative valve connected to the vacuum system

When using another vent valve, ensure that a suitable vent restrictor is fitted to the vacuum system to limit the rate of pressure rise.

Refer to [Table 8](#) on page 50 for information about vent restrictor sizes. If a suitable vent restrictor is not fitted, open the vent valve only after the speed of the pump has fallen to 50% of full rotational speed.

Table 8 Vent restrictor orifice diameter if venting the vacuum system chamber

Vacuum system volume (litres)	Orifice diameter (mm)
< 20	< 1.0
< 10	< 0.7
< 5	< 0.5
< 2	< 0.35

Operation with parallel control and monitoring

Start the pump with parallel control



WARNING:

Do not operate the pump with its rotor exposed. Before operating the pump it must first be connected to the vacuum system. If the pump is operated with its rotor exposed, the pump rotor can cause injury as it rotates at very high speeds and the rotating blades might not be visible.

**WARNING:**

Do not move the pump whilst it is running. The gyroscopic forces generated by this movement can cause excessive use of the back-up bearing and may result in catastrophic failure of the pump.

**WARNING:**

When power is restored following a power cut, the pump will restart automatically. The pump must remain connected to the vacuum system to prevent risk of injury.

In parallel control the pump will accelerate to full operating speed when started.

Start the nEXT85 pump by linking the start/stop control input to the 0 V control reference on the logic interface connector.

The green indicator on the motor controller will illuminate when the pump reaches normal speed. This is 80% of full rotational speed by default but a different value may have been selected to suit the application.

Run the pump at standby speed with parallel control

If the pump is running below or above standby speed it will accelerate or decelerate until standby speed is reached.

1. To run the nEXT85 pump at standby speed, link the standby control input to the 0 V control reference on the logic interface connector.
2. To return the pump to full speed, disconnect the standby control input from the 0 V control reference on the logic interface connector.

Stop the pump with parallel monitoring

**WARNING:**

After power to the pump has been switched off, either through emergency or as a requirement, the rotor will continue to spin at very high speeds. The rotor possesses considerable mechanical energy until it slows down/stops.

**WARNING:**

Do not remove the controller from the pump until the pump is completely at rest. The exposed electrical pins may pose a potential hazard. The user could also be exposed to a back e.m.f. from the pump and potentially damage the controller.

With parallel control the pump rotor will decelerate to rest when stopped.

Stop the nEXT85 pump by disconnecting the start/stop control input from the 0 V control reference on the logic interface connector.

Parallel monitoring

Analogue output, normal signal and fail signal parameters can be monitored.

Refer to [Connect the parallel control and monitoring](#) on page 28 for instructions on how to monitor these signals.

Operation with serial control and monitoring

Delayed start with serial control

When using a TAV solenoid valve controlled by the motor controller, it can be closed before starting the nEXT85 pump. This allows the backing pump to reduce the pressure in the vacuum system.

1. To close the vent valve, send the following command:

Command	!	C	8	7	5	sp	1	cr											
---------	---	---	---	---	---	----	---	----	--	--	--	--	--	--	--	--	--	--	--

2. The reply will be in the following format:

Reply	*	C	8	7	5	sp	r	cr											
-------	---	---	---	---	---	----	---	----	--	--	--	--	--	--	--	--	--	--	--

 **Note:**

This command overrides the current vent option and closes the vent valve. There is no open vent valve command but, when a stop command is sent to the pump, the override is cleared.

Start the pump with serial control



WARNING:

Do not operate the pump with its rotor exposed. Before operating the pump it must first be connected to the vacuum system. If the pump is operated with its rotor exposed, the pump rotor can cause injury as it rotates at very high speeds and the rotating blades might not be visible.



WARNING:

Do not move the pump whilst it is running. The gyroscopic forces generated by this movement can cause excessive use of the back-up bearing and may result in catastrophic failure of the pump.



WARNING:

When power is restored following a power cut, the pump will restart automatically. The pump must remain connected to the vacuum system to prevent risk of injury.

In serial control the pump will accelerate to full operating speed when started.

1. To start the pump, send the following command over the serial communications link:

Command	!	C	8	5	2	sp	1	cr											
---------	---	---	---	---	---	----	---	----	--	--	--	--	--	--	--	--	--	--	--

2. The reply will be in the following format:

Reply	*	C	8	5	2	sp	1	cr											
-------	---	---	---	---	---	----	---	----	--	--	--	--	--	--	--	--	--	--	--

The green indicator LED will illuminate when the pump reaches normal speed. This is 80% of full rotational speed by default but a different value may have been selected to suit the application.

Run the pump at standby speed with serial control

If the pump is running below or above standby speed it will accelerate or decelerate until standby speed is reached.

1. To run the nEXT85 pump at standby speed, send the following command over the serial communications link:

Command	!	C	8	6	9	sp	1	cr												
---------	---	---	---	---	---	----	---	----	--	--	--	--	--	--	--	--	--	--	--	--

2. The reply will be in the following format:

Reply	*	C	8	6	9	sp	r	cr												
-------	---	---	---	---	---	----	---	----	--	--	--	--	--	--	--	--	--	--	--	--

3. To return the pump to full speed, send the following command:

Command	!	C	8	6	9	sp	0	cr												
---------	---	---	---	---	---	----	---	----	--	--	--	--	--	--	--	--	--	--	--	--

4. The reply will be in the following format:

Reply	*	C	8	6	9	sp	r	cr												
-------	---	---	---	---	---	----	---	----	--	--	--	--	--	--	--	--	--	--	--	--

Stop the pump with serial control

On successful receipt of the stop command, the pump rotor will decelerate to rest.

1. To stop the nEXT85 pump, send the following command over the serial communications link:

Command	!	C	8	5	2	sp	0	cr												
---------	---	---	---	---	---	----	---	----	--	--	--	--	--	--	--	--	--	--	--	--

2. The reply will be in the following format:

Reply	*	C	8	5	2	sp	r	cr												
-------	---	---	---	---	---	----	---	----	--	--	--	--	--	--	--	--	--	--	--	--

Monitor temperature readings with serial control

The temperatures of the pump motor, rotor and the internal electronics of the nEXT85 pump can be monitored.

1. Send the following query:

Command	?	V	8	6	5	cr														
---------	---	---	---	---	---	----	--	--	--	--	--	--	--	--	--	--	--	--	--	--

2. The reply will be as follows, where the first number is the motor temperature and the second number is the motor controller temperature and the third number is the rotor temperature, all measured in °C:

Reply	=	V	8	6	5	sp	d	d	d	;	d	d	d	;	d	d	d	cr		
-------	---	---	---	---	---	----	---	---	---	---	---	---	---	---	---	---	---	----	--	--

Monitor link parameter readings with serial control

The internal voltage, current and motor power of the nEXT85 pump can be monitored.

1. Send the following query:

Command	?	V	8	6	0	cr														
---------	---	---	---	---	---	----	--	--	--	--	--	--	--	--	--	--	--	--	--	--

2. The reply will be in the following format (where the first number refers to link voltage (measured in 0.1 Volts – i.e. divide the number by 10 to get an answer in Volts), the second number refers to link current (measured in 0.1 Amps) and the third number refers to link power (measured in 0.1 Watts)):

Reply	=	V	8	6	0	sp	d	d	d	;	d	d	d	;	d	d	d	d	d	cr
-------	---	---	---	---	---	----	---	---	---	---	---	---	---	---	---	---	---	---	---	----

Monitor measured motor speed with serial control

The measured rotational speed of the motor inside the nEXT85 pump can be monitored.

1. Send the following query:

Command	?	V	8	5	2	cr														
---------	---	---	---	---	---	----	--	--	--	--	--	--	--	--	--	--	--	--	--	--

2. The reply will be in the following format, where the first returned number refers to motor rotational speed in revolutions per second (Hz):

Reply	=	V	8	5	2	sp	d	d	d	d	;	h	h	h	h	h	h	h	h	h	cr
-------	---	---	---	---	---	----	---	---	---	---	---	---	---	---	---	---	---	---	---	---	----

 **Note:**

The second return number is a 32-bit system status word (set of 8 hexadecimal characters) which is useful for fault finding. Refer to [Troubleshooting](#) on page 67 for advice fault finding.

Mixed parallel and serial operation

In mixed parallel and serial operation the pump may receive commands from both serial and parallel interfaces.

To understand how these commands control the pump, refer to [Figure 7](#) on page 33. The pump will power up with 'None in Control'. From this state a parallel start signal or a serial start command may be received, resulting in the pump moving to parallel control mode or serial control mode respectively. Serial start commands will only be received if the serial enable line is active.

The state of the serial enable line may be switched between active and inactive whilst in mixed parallel and serial operation. The primary function of the serial enable line is to enable the serial link. It has no direct effect on the control mode. The pump will receive and respond to serial commands whenever the serial enable line is active, and conversely will not receive or respond to serial commands when the serial enable line is inactive.

Availability of the parallel standby and fail signals depends on the state of the serial enable line and the position of the RS485/RS232 switch as described in [Table 9](#) on page 54.

Table 9 Serial enable matrix

Switch	Serial enable active	Serial enable inactive
RS232	Standby and fail lines are used for RS232 data.	Standby and fail lines are used for parallel Standby control and fail indication.
	Parallel standby control and fail indication are disabled.	Serial communications are disabled.
RS485	Standby and fail lines are used for RS485 data.	Standby and fail lines are in (RS485) high impedance state. *
	Parallel standby control and fail indication are disabled.	Serial communications are disabled.

* Pump target speed will switch between run speed and standby speed in response to any data driven onto the RS485 bus by other devices connected to the bus. Activation of the parallel start line not recommended with the RS485/232 switch in RS485 position and serial enable Inactive. Deactivation of the serial enable line is not recommended with the pump running following a start from the parallel start line when the RS485/232 switch is in the RS485 position.

In parallel control mode, the pump will not accept serial stop commands but will accept all other serial commands. When serial enable is active, the pump will run at standby speed if it has been commanded to do so by a serial standby command. When Serial enable is inactive and the RS485/RS232 switch is in RS232 position, the pump will run at standby speed when the parallel standby line is active.

In serial control mode, the state of the parallel Start line will be ignored but the serial enable line provides an interlock function as shown in [Figure 9](#) on page 55. This interlock function only operates with serial start commands and therefore only in serial control mode. In serial control mode, the pump cannot be commanded to standby speed by the standby line, instead a serial standby command must be used.

The parallel normal and analogue output signals provide valid pump status information at all times under mixed parallel and serial operation. The analogue output voltages are described in [Table 48](#) on page 96.

Figure 9 Serial and parallel control flowchart

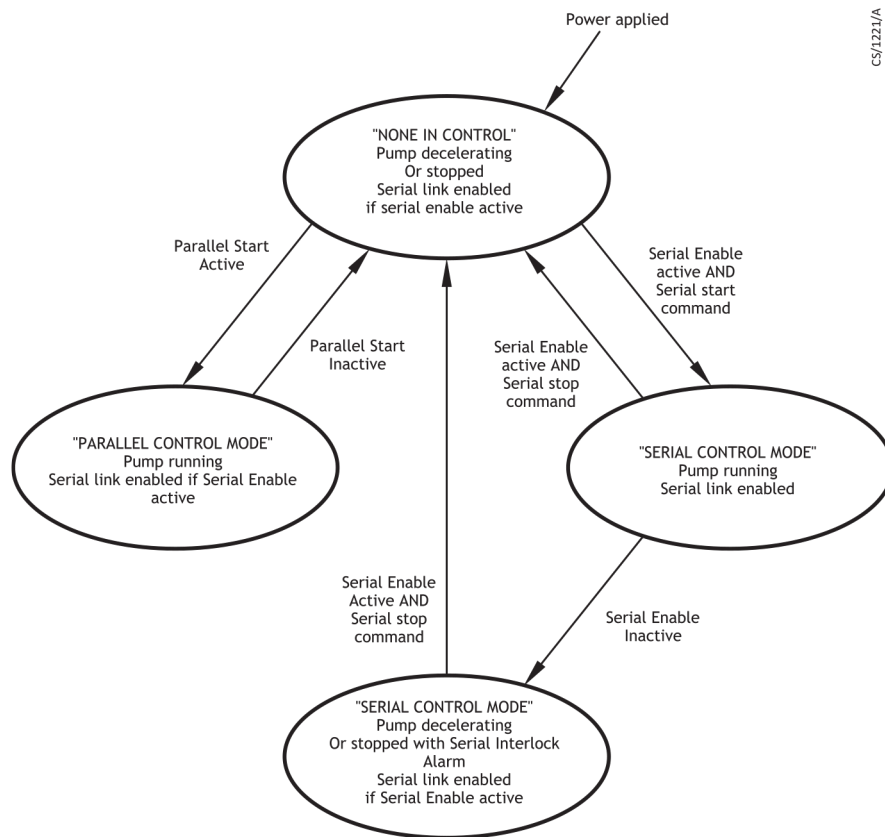

CS/1221/A

Operation with a TIC or TAG

The nEXT85 pump can be connected directly to an Edwards TIC Turbo Instrument Controller, TIC Turbo Controller or TAG Controller. The TIC will provide the power necessary to drive the nEXT85 pump, but the TAG requires a separate PSU to be connected.

Instructions on the setup and operation with the TIC Turbo Instrument Controller, TIC Turbo Controller or TAG Controller can be found on CD ROM part number P450-00-000, which is supplied with the TIC or TAG.

Decelerating and venting

Allow the pump to decelerate before venting.

The system may be vented in accordance with the advice given in [Vent options, vent valve connection and control](#) on page 47.



CAUTION:

Do not open a manual vent valve until the pump rotational speed has fallen below 50%, otherwise the rate of pressure rise may be too high, which could damage the pump. In an emergency only, open the vent valve quickly to decelerate the pump rotor in the shortest possible time.

If using the motor controller to control a TAV solenoid valve, there is a 2-second delay between either a stop command being received or a fault condition being detected and the vent valve opening. This delay allows time for gauges, valves and other equipment to be switched off before venting occurs.

The green indicator LED on the motor controller will extinguish as rotational speed drops below normal speed. At very low speeds, the yellow indicator LED will flash and will extinguish when the pump has stopped.

The deceleration time can be improved by using the electronic braking feature, refer to [Electronic braking options](#) on page 42.

Operation at extreme conditions

Operation with high inlet pressure

If the nEXT85 pump inlet pressure rises, the power supplied to the pump motor will increase to counteract the gas frictional load.

The pump rotational speed will remain constant until the peak power level is reached; beyond this level, the speed of the pump will start to reduce.

If the pump speed falls to below 50% of full rotational speed, the timer will start if it is enabled. If the speed does not recover to above 50% speed before the timeout period expires, the pump will shut down and display a fail signal. If the timer is disabled, the pump will immediately shut down and display a fail signal if the speed drops below 50% of full rotational speed. Refer to [Electrical data](#) on page 95 for the maximum power delivered to the pump and to [Table 38](#) on page 88, for maximum allowable inlet pressure.

Operation at high temperatures

Temperature sensors within the pump mechanism and electronics are monitored by an internal system.

If the system detects that any internal temperatures are too high, the power supplied to the pump motor is reduced; the pump may not therefore be able to maintain full rotational speed if it is too hot.

If the pump speed falls to below 50% of full rotational speed, the timer will start if it is enabled. If the speed does not recover to above 50% speed before the timeout period expires, the pump will shut down and display a fail signal. If the timer is disabled, the pump will immediately shut down and display a fail signal if the speed drops below 50% of full rotational speed. Refer to [Table 36](#) on page 86 for pump operating ranges and [Cooling](#) on page 33 for advice on pump cooling.

Protection against over-speed

Control software within the motor controller regulates the pump rotational speed and prevents the pump operating above its normal full rotational speed.

In the unlikely event of a failure of this control software, the motor controller has a built-in safety circuit that checks whether the pump is running at over-speed. If an over-speed condition is detected, the motor controller automatically shuts down power to the pump motor and slows it down to rest. The motor controller will signal a fail condition if over-speed has been detected.

If the pump appears to be running at over-speed, switch it off and consult Edwards or the supplier.

Electrical supply failure

If the electrical supply to the nEXT85 pump fails when the pump is rotating, the motor of the pump is used as a generator.



WARNING:

If the power supply fails when the pump is running, the rotor could continue to spin for approximately 30 minutes. The control circuit may not give any indication that the rotor is still running.



WARNING:

If the parallel start control signal on the logic interface connector is set to start, the pump may automatically restart when the electrical supply is restored after an electrical supply failure. Ensure that people cannot be injured by the rotating blades of the pump.

The regenerated power is used to maintain the output signals on the logic interface (such as the normal signal and serial communications), to power the indicator LEDs on the motor controller and to maintain power at the motor controller auxiliary outputs (to control the vent valve and / or fan, if fitted). The regenerated power is also available at the power supply pins of the logic interface connector, but only when electronic braking is enabled (refer to [Electronic braking](#) on page 17). This could be used to power other instruments through short power interruptions. The minimum voltage of this supply will be 24 V -20% (19.2 V) provided that the external load is not excessive and it can be sustained at that minimum voltage when operating from supply voltages above 48 V d.c. -20% and below 48 V d.c. +5%.

As the pump rotational speed decreases, the motor's ability to generate power also decreases until it is no longer able to maintain power to the logic interface or LEDs. This will occur at speeds below 50% full rotational speed. In this case, there will be no indication of pump rotational speed, yet the rotor may still be turning.

When the power is reinstated after a power failure, the behavior of the pump will depend on the control mode at the time of failure (parallel or serial) and the length of time the pump was without power. [Table 10](#) on page 58 shows a number of scenarios.

Table 10 Behaviour of a pump when the power is re-instated after an electrical supply failure

Length of power failure	Control mode	Behaviour of pump
Power is reinstated before pump rotational speed falls below 50%	Either parallel or serial control mode	Regenerative power maintains all output signals during the power failure. The pump will ramp to its designated speed as quickly as possible after the power has been restored.
Power is reinstated after pump rotational speed falls below 50% but before regenerative power ceases	Either parallel or serial control mode, timer disabled	Regenerative power maintains all output signals during the power failure. As the timer is disabled, the motor controller will go into fail condition as soon as speed falls below 50% and will display flashing error code 0. When the power is reinstated, the pump will not ramp up until the error is cleared. To clear the error, send a stop command (either parallel or serial, depending on the control mode), then send a start command to ramp the pump up to the designated speed.
	Either parallel or serial control mode, timer enabled	Regenerative power maintains all output signals during the power failure. If power is reinstated before the timer period expires, the pump will ramp up to its designated speed as quickly as possible. If the timer period expires, the motor controller will go into fail condition and will display flashing error code 3. As above, when the power is reinstated, the pump will not ramp up until the error is cleared. To clear the error, send a stop command (either parallel or serial, depending on the control mode), then send a start command to ramp the pump up to the designated speed.
Power is reinstated after pump rotational speed falls below 50% and the regenerative power ceases	Either parallel or serial control mode	Regenerative power ceases and fails to maintain output signals. When power is reinstated, the pump with parallel control will automatically restart if the start control on the logic interface is set to start. The pump with serial control will require a new start command to ramp the pump up to the designated speed. Any fail signals that were triggered during the regenerative power period are lost when the power is reinstated.

Bakeout

If the pump (and the vacuum system) are heated, the degassing process will speed up and the pump will reach ultimate vacuum in the shortest possible time. Heating the pump will also prevent condensation of vapours inside the pump.



WARNING:

Do not touch the flange heater or surrounding surfaces during the bakeout process as they will be hot.

**CAUTION:**

Pumps with ISO flanges are not suitable for bakeout, only pumps with CF flanges must be used. When baking the pump to above 70 °C at the inlet flange, the pump must be water cooled to prevent damage to the bearing lubricant.

The Edwards flange heater may be used to heat the pump (refer to [Accessories for the nEXT85](#) on page 80). Fit the appropriate band around the pump CF inlet flange. When baking the pump or the system, make sure that the temperature of the inlet flange does not exceed the values specified in [Table 37](#) on page 86.

When baking the vacuum system, if the temperature of the system exceeds 200 °C, put a radiation shield between the system and the pump. This radiation shield will reduce the heat radiated onto the pump rotor.

Typically, a bakeout of four hours is long enough to remove water condensation from the pump. However, the bakeout time will depend on the amount of condensation in the pump and the vacuum system, and the ultimate pressure desired.

Shut down the pump manually

**CAUTION:**

To prevent condensation inside the pump and motor controller, turn off the cooling water when the pump is switched off.

 **Note:**

In an emergency only, open the vent valve quickly to decelerate the pump rotor in the shortest possible time.

Use this procedure to shut down a basic, manually-controlled pumping system with a manual vent valve.

1. Turn off the pump, but keep the backing-pump on and backing valve open.
2. When speed has fallen to 50%, open the vent valve.
3. When the pump reaches standstill, the vent valve and backing valve may be closed and backing pump switched off.

Maintain the nEXT85



WARNING:

When removing the pump, ensure personal protective equipment is used to safeguard against damage from failed components and possible accumulation of hazardous material that may have been pumped. Check that the pump is vented to atmosphere and at a safe temperature. Be wary of possible spillages, sharp edges and debris. Removal of the pump inlet screen will always expose the risk of injury from sharp edges.



WARNING:

Allow the pump rotor to stop and then disconnect the motor controller before you remove the pump from your vacuum system for maintenance or fault finding procedures.

<i>Bearing and oil cartridge maintenance</i>	The oil cartridge and oil-lubricated bearing must be replaced when it reaches the end of its service life. This is typically after 35,000 hours.
<i>Rotor life</i>	The fatigue life of nEXT85 Turbomolecular pump rotors is typically 40,000 to 50,000 cycles. As a precautionary measure, Edwards recommends that pumps are returned for a major service (rotor replacement) after 20,000 cycles of acceleration to full speed and back to a stop, or after ten years of use, whichever occurs first.
<i>Cleaning the pump</i>	If the inside of the pump is contaminated, it may not be possible to achieve the specified ultimate vacuum performance, or pump-down times may increase.
<i>Decoding service status words</i>	The service status may be accessed directly via the serial link. This method of accessing service status will give the most complete picture of current and future service requirements and will allow preventative maintenance activities to be scheduled.
<i>Controller run time</i>	The run hours and recommended service time of the controller on the nEXT85 pump can be monitored.
<i>Pump run time</i>	The run hours and recommended service time of the rotor in the nEXT85 pump can be monitored.
<i>Pump cycles</i>	The number of start-stop cycles completed and the number remaining until the next service is due can be monitored.
<i>Bearing run time</i>	The run hours and recommended service time of the bearing in the nEXT85 pump can be monitored.
<i>Oil cartridge run time</i>	The run hours and recommended service time of the oil cartridge in the nEXT85 pump can be monitored.

Bearing and oil cartridge maintenance

The oil cartridge and oil-lubricated bearing must be replaced when it reaches the end of its service life. This is typically after 35,000 hours.

When the oil cartridge and/or bearing need replacing, Edwards recommends:

- Send the pump to an Edwards Service Centre for a bearing and/or oil cartridge replacement.
- Purchase an oil cartridge or bearing service kit and replace the bearing and/or oil cartridge on-site (refer to [Service](#) on page 76) .

Rotor life

The fatigue life of nEXT85 Turbomolecular pump rotors is typically 40,000 to 50,000 cycles. As a precautionary measure, Edwards recommends that pumps are returned for a major service (rotor replacement) after 20,000 cycles of acceleration to full speed and back to a stop, or after ten years of use, whichever occurs first.

Cleaning the pump



WARNING:

Clean the external surfaces of the pump in a well ventilated location. When using cleaning solutions and solvents to clean the pump, observe all precautions specified by the manufacturer. Avoid inhalation of any particulates which may be present in the pump.



CAUTION:

Do not attempt to clean any parts of the pump other than external surfaces. Organic solvents may damage internal pump components. Do not use abrasive materials to clean any part of the pump.

If the inside of the pump is contaminated, it may not be possible to achieve the specified ultimate vacuum performance, or pump-down times may increase.

In these circumstances the pump must be returned to an Edwards Service Centre where the pump will be dismantled and cleaned. Use the procedures in [Figure 24](#) on page 108 and [Figure 25](#) on page 109 to return the pump.

Any organic solvent can be used to clean the external surfaces of the pump. Edwards recommend the use of non-CFC solvents such as isopropanol or ethanol. Only a minimal amount of a cleaning solution is required which is suitable for the contaminants on the pump surfaces.

For environmental reasons, keep wastage of cleaning solutions and solvents to a minimum.

Decoding service status words

The service status may be accessed directly via the serial link. This method of accessing service status will give the most complete picture of current and future service requirements and will allow preventative maintenance activities to be scheduled.

A summary of the current pending service status is provided in response to the service status command:

Command	?	V	8	8	1	cr													
---------	---	---	---	---	---	----	--	--	--	--	--	--	--	--	--	--	--	--	--

The reply will be as follows:

Reply	=	V	8	8	1	sp	h	h	h	h	h	h	h	h	h	cr			
-------	---	---	---	---	---	----	---	---	---	---	---	---	---	---	---	----	--	--	--

The service status word is made up of 8 hexadecimal digits. To decode this word, convert each digit into a 4-digit binary number in the same manner as the system status word, which is described in [Decoding system status words](#) on page 72.

Each binary digit (bit) represents a flag that is either active (state 1) or not active (state 0). To help decode the service status word, each bit is numbered (starting with 0 for the least significant to 31 for the most significant) as shown in [Decoding system status words](#) on page 72. The meaning of each bit in the service status word is given in [Flashing service codes](#) on page 71.

Table 11 Service flags

Bit number	Status flag	Active flag means
0	Oil cartridge service due	Set when hours until oil cartridge service due = 0
1	Bearing service due	Set when hours until bearing service due = 0
2	Pump service due	Set when hours until pump service due = 0 or cycles until pump service due = 0
3	Controller service due	Set when hours until controller service due = 0
4	Reserved	-
5	Reserved	-
6	Reserved	-
7	Service due	Service is due. Specific operation required should be determined by checking the bits above
8 - 31	Reserved	-

Controller run time

The run hours and recommended service time of the controller on the nEXT85 pump can be monitored.

Send the following query:

Command	?	V	8	8	2	cr													
---------	---	---	---	---	---	----	--	--	--	--	--	--	--	--	--	--	--	--	--

The reply will be as follows, where the first number is the hours run by the controller and the second is the number of hours until service is recommended:

Reply	=	V	8	8	2	sp	d	d	d	d	d	d	;	d	d	d	d	d	d	cr
-------	---	---	---	---	---	----	---	---	---	---	---	---	---	---	---	---	---	---	---	----

Note that the number of hours until the next service is due is estimated by the controller based on the operating conditions of the pump and therefore may reduce at more or less than 1 hour per hour. The dominant factor in extending controller life is reduced pump temperature.

Pump run time

The run hours and recommended service time of the rotor in the nEXT85 pump can be monitored.

Send the following query:

Command	?	V	8	8	3	cr													
---------	---	---	---	---	---	----	--	--	--	--	--	--	--	--	--	--	--	--	--

The reply will be as follows, where the first number is the hours run by the rotor and the second is the number of hours until service is recommended:

Reply	=	V	8	8	3	sp	d	d	d	d	d	d	;	d	d	d	d	d	d	cr
-------	---	---	---	---	---	----	---	---	---	---	---	---	---	---	---	---	---	---	---	----

Pump cycles

The number of start-stop cycles completed and the number remaining until the next service is due can be monitored.

Send the following query:

Command	?	V	8	8	4	cr													
---------	---	---	---	---	---	----	--	--	--	--	--	--	--	--	--	--	--	--	--

The reply will be as follows, where the first number is the start-stop cycles completed by the pump and the second is the number of start-stop cycles until service is recommended:

Reply	=	V	8	8	4	sp	d	d	d	d	d	d	;	d	d	d	d	d	d	cr
-------	---	---	---	---	---	----	---	---	---	---	---	---	---	---	---	---	---	---	---	----

Bearing run time

The run hours and recommended service time of the bearing in the nEXT85 pump can be monitored.

Send the following query:

Command	?	V	8	8	5	cr													
---------	---	---	---	---	---	----	--	--	--	--	--	--	--	--	--	--	--	--	--

The reply will be as follows, where the first number is the hours run by the bearing and the second is the number of hours until service is recommended:

Reply	=	V	8	8	5	sp	d	d	d	d	d	d	;	d	d	d	d	d	d	cr
-------	---	---	---	---	---	----	---	---	---	---	---	---	---	---	---	---	---	---	---	----

Oil cartridge run time

The run hours and recommended service time of the oil cartridge in the nEXT85 pump can be monitored.

Send the following query:

Command	?	V	8	8	6	cr													
---------	---	---	---	---	---	----	--	--	--	--	--	--	--	--	--	--	--	--	--

The reply will be as follows, where the first number is the hours run by the oil cartridge and the second is the number of hours until service is recommended:

Reply	=	V	8	8	6	sp	d	d	d	d	d	d	;	d	d	d	d	d	d	cr
-------	---	---	---	---	---	----	---	---	---	---	---	---	---	---	---	---	---	---	---	----

Storage

Avoid long-term storage if possible. When long-term storage is necessary, the pump should be set up and run for at least eight hours every six months.

Use the following procedure to store the pump.

1. Place protective covers over all ports, the main inlet, inter-stage exhaust, purge and vent ports.
2. Place the pump in its packing materials. For fastest pump-down when the pump is put back into service, seal the pump inside a plastic bag together with a suitable desiccant.
3. Store the pump in cool, dry conditions, preferably not exposed to atmospheric air until required for use. When required, prepare and install the pump as described in [Install the nEXT85](#) on page 20.
4. Keep the pump upright at all times to prevent the drainage of oil from the bearing reservoir.

Disposal



WARNING:

In the unlikely event of a failure of the pump rotor, there may be some dust created from the rotary components inside the pump touching each other. In this event use appropriate personal protective equipment when handling and disposing of the pump and ensure that all pump inlets and outlets are capped off before disposal.

Take appropriate action to avoid inhalation of any particulates which may be present in the pump. Do not incinerate the pump.

A HS2 form must be completed if returning the pump to Edwards.

Dispose of the pump and any components and accessories safely and in accordance with all local and national safety and environmental requirements.

Particular care must be taken with any components that have been contaminated with dangerous process substances.

Take appropriate action to avoid inhalation of any particles that may be present in the pump.

Do not incinerate the pump. The pump contains phenolic and fluorosilicone materials that can decompose to very dangerous substances when heated to high temperatures.

Troubleshooting

A list of fault conditions and their possible causes is provided here to assist in basic troubleshooting. If unable to rectify a fault when using this guide, call your supplier or your nearest Edwards Service Centre for advice.

Symptom
The controller LEDs do not flash for 0.5 seconds when system switched on on page 67
The pump does not rotate after a parallel start command is supplied on page 67
The pump does not rotate after a serial start command is sent on page 67
The pump does not respond in multi-drop mode on page 68
The green Normal LED does not light or the pump is not rotating at full speed or the pump fails whilst running on page 68
Ultimate pressure cannot be reached on page 68
The pump is very noisy or there is excessive vibration or both on page 69
No serial comms on page 69
Fail signal or standby signal not working on page 69
Yellow service LED is flashing a repeated sequence on page 69
The red alarm LED is on on page 70
The red alarm LED is flashing on page 70
Any other problems on page 70

The controller LEDs do not flash for 0.5 seconds when system switched on

Cause The electrical supply has failed.

Remedy Ensure that the electrical supply is switched on and the fuses (and current limiting devices) have not been tripped.

Cause The pump rotor is spinning.

Remedy The LEDs may not flash if the pump is rotating.

The pump does not rotate after a parallel start command is supplied

Cause Check that the electricity supply is on and whether the fail output is active.

Remedy If there is a fail signal, check whether the red alarm LED is flashing. If it is, refer to [Flashing error codes](#) on page 71. If power is supplied, there is no fail signal and the rotor still does not rotate then there is a fault with the pump.

The pump does not rotate after a serial start command is sent

Cause Check whether the pump returns a reply to the start command.

Remedy If there is no reply then perform the checks given under [No serial comms](#) on page 69 otherwise perform the checks under [The pump does not rotate after a parallel start command is supplied](#) on page 67.

The pump does not respond in multi-drop mode

Cause The multi-drop is disabled.

Remedy Make sure the pump has a multi-drop address and that commands are sent using the multi-drop protocol.

The green Normal LED does not light or the pump is not rotating at full speed or the pump fails whilst running

Cause The inlet pressure is too high.

Remedy Reduce the pumping load or check for a gross leak into the system.

Cause The pump is running too hot.

Remedy Increase the cooling to the pump. Change from air cooling to water cooling (refer to [Table 38](#) on page 88 for maximum inlet pressure and cooling requirements).

Increase cooling water flow or decrease the water temperature or do both.

Check that external heat sources (such as system bakeout heaters) are not excessive.

Cause The rotor does not rotate freely.

Remedy The pump bearings may be damaged. Contact the supplier or Edwards.

Ultimate pressure cannot be reached

Cause Pressure is limited by water vapour.

Remedy Bake the system and pump.

Cause The vacuum gauges are contaminated.

Remedy Clean or replace the vacuum gauges.

Cause Pumping speed is insufficient due to poor conductance between the pump and the gauge or the chamber is too large.

Remedy Increase the conductance or reduce the volume.

Cause Inlet pressure is > 0.5 mbar (50 Pa).

Remedy If the interstage inlet pressure is too high, inlet pressure at the turbomolecular inlet is increased; ensure that the interstage inlet pressure is < 0.5 mbar (50 Pa).

Cause The backing pressure is > 10 mbar (1×10^3 Pa).

Remedy The backing pressure may be too high. Check for backing pipeline leaks. If the throughput is high, a larger backing pump may be required.

Cause The high vacuum area of the system is contaminated.

Remedy Clean the high vacuum system.

Cause Check the rest of the system for leaks and contamination.

Remedy If found, repair the leaks and clean the contamination.

Cause The inlet pressure is poor.

Remedy Remove the pump from the system and test the ultimate pressure of the pump alone (refer to [Table 38](#) on page 88).

If inlet pressure is poor, check the pump for contamination and refer to [Table 38](#) on page 88.

Leak test the pump. If the leak rate $> 1 \times 10^{-7}$ mbar l s⁻¹ (1×10^{-5} Pa l s⁻¹), contact the supplier or Edwards.

The pump is very noisy or there is excessive vibration or both

Cause The pump rotational speed is the same as the resonant frequency of the attached system.

Remedy Change the natural frequency of the system or isolate the pump using flexible bellows.

Cause The vibration is being transmitted from the rotary backing pump.

Remedy Fit flexible bellows or a vibration isolator in the backing line.

Cause The noise is irregular and getting progressively worse.

Remedy There is a defective bearing. Contact the supplier or Edwards.

Cause The pump is making a constant high pitched noise.

Remedy The rotor is out of balance. Contact the supplier or Edwards.

No serial comms

Cause No electrical supply, loss of serial link.

Remedy Check that the electrical supply is on, that the serial link is connected and that the serial enable line is active.

Cause Slide switch is not in the correct position for RS232 or RS485.

Remedy Check that the electrical supply is on, that the serial link is connected and that the serial enable line is active.

Left for RS485, right for RS232.

Right for parallel control and monitoring.

Cause Incorrect baud rate and node address.

Remedy Check baud rate and, if operating in multi-drop mode, the node address matches those of the pump.

Cause Check that the red light is not on or flashing.

Remedy If LED is on, perform the checks against the red alarm LED symptoms

Fail signal or standby signal not working

Cause The serial enable line is inactive.

Remedy Must be disconnected or driven high for use of standby and fail lines.

Cause Slide switch is not in the correct position for RS232 or RS485.

Remedy Left for RS485, right for RS232.

Right for parallel control and monitoring.

Yellow service LED is flashing a repeated sequence

Cause A service is required.

Remedy See [Flashing service codes](#) on page 71.

The red alarm LED is on

Cause Normal during the software upgrade process. At other times indicates a problem has been detected in the FLASH memory.

Remedy If during software upgrade then complete the upgrade process. Otherwise cycle power and if this does not help then perform a software upgrade.

The red alarm LED is flashing

Cause A fail condition has become active.

Remedy Note the position of the long flashes within the series of 6 flashes to work out the error code. Look up the flashing error code in [Flashing error codes](#) on page 71 and follow the advice given.

Any other problems

Cause Fault conditions other than the ones previously mentioned.

Remedy Contact the supplier or Edwards.

Command set error codes

Error codes that may be returned for serial control and monitoring.

Table 12 Command set error codes

Returned error code	Meaning
0	No error
1	Invalid command for object ID
2	Invalid Query/Command
3	Missing parameter
4	Parameter out of range
5	Invalid command in current state - e.g. serial command to start/stop when in parallel control mode

Flashing service codes

Whenever a service is required the standard once per revolution flash on the yellow status LED is replaced with a service flash code.

Table 13 Flashing service codes

Service flash code	Comments	Actions
LED on 1 sec LED off 1 sec	Oil cartridge service recommended	It is recommended that the oil cartridge is replaced. Refer to Bearing and oil cartridge on-site maintenance .
LED on 3 sec LED off 1 sec	Bearing and oil cartridge service recommended	It is recommended that the bearing and oil cartridge are replaced. Refer to Bearing and oil cartridge on-site maintenance .
LED on 3 sec LED off 3 sec	Pump service required	The turbo rotor or controller has reached its expected life. It is recommended that the pump is returned to an Edwards service centre for service. Refer to Service .

Flashing error codes

Whenever a fail condition becomes active, the red alarm lights continuously or shows a flashing sequence.

If the error light is on continuously, this indicates a problem with the embedded software. In this case, try cycling the power. If cycling the power does not clear the indication, a software download will be required. Contact the supplier or Edwards. If the alarm LED is flashing, identify the error flash code and consult the table in [Decoding system status words](#) on page 72.

There is a sufficient off period between each subsequent cycle repetition to clearly mark the start of a new flash sequence. The duration of a long flash (L) is equal to 3 times the duration of a short flash (0.5 s).

Table 14 Flashing error codes

Error flash position	Error flash code	Comments	Actions
0	ssssss	The speed fell below 50% of full rotational speed with the timer disabled.	Check whether the pump is too hot or whether the inlet pressure is too high.
1	Lsssss	Controller internal software mismatch.	Cycle the power to the pump and see whether the error code appears again. If it does, contact the supplier or Edwards.

Error flash position	Error flash code	Comments	Actions
2	sLssss	Controller failed internal configuration and calibration operation.	Cycle the power to the pump and see whether the error code appears again. If it does, contact the supplier or Edwards.
3	ssLsss	Failure to reach or maintain half full speed within the timer setting value.	Check whether the pump is too hot or whether the inlet pressure is too high.
4	sssLss	Overspeed or overcurrent trip activated, or other hardware fault.	Cycle the power to the pump and see whether the error code appears again. If it does, contact the supplier or Edwards.
5	ssssLs	Pump internal measurement system disconnected or damaged.	Cycle the power to the pump and see whether the error code appears again. If it does, contact the supplier or Edwards.
6	ssssL	Serial enable becomes inactive following a serial start command.	Re-activate serial enable and send a serial stop command to clear the error code.

 **Note:**

The alarm LED error flash sequence is capable of signaling multiple fail conditions. For example, error flash code sLsLs signifies both error 2 (controller failed internal configuration and calibration operation) and error 5 (pump internal measurement system disconnected or damaged).

Decoding system status words

If using the serial communications link, additional information, that may be useful for fault finding, can be accessed.

When sending a query to monitor measured motor speed, the pump also returns a system status word.

The send command is as follows:

Command	?	V	8	5	2	cr													
---------	---	---	---	---	---	----	--	--	--	--	--	--	--	--	--	--	--	--	--

The reply will be as follows, where the first part returned is a number refers to motor rotational speed in revolutions per second (Hz) and the second part is the system status word:

Reply	=	V	8	5	2	sp	d	d	d	d	;	h	h	h	h	h	h	h	cr
-------	---	---	---	---	---	----	---	---	---	---	---	---	---	---	---	---	---	---	----

The system status word returned is made up of 8 hexadecimal digits. To decode this word, convert each digit into a 4-digit binary number. Follow the example below:

2	2	8	3	0	0	2	2
---	---	---	---	---	---	---	---

0010	0010	1000	0011	0000	0000	0010	0010
------	------	------	------	------	------	------	------

The following table is provided as an aid.

Table 15 Hexadecimal conversion table

Hexadecimal	Binary	Decimal
0	0000	0
1	0001	1
2	0010	2
3	0011	3
4	0100	4
5	0101	5
6	0110	6
7	0111	7
8	1000	8
9	1001	9
A	1010	10
B	1011	11
C	1100	12
D	1101	13
E	1110	14
F	1111	15

Each binary digit (bit) represents a flag that is either active (state 1) or not active (state 0). To help decode the system status word, each bit is numbered (starting with 0 for the least significant to 31 for the most significant) as shown below.

Binary digits																																					
0	0	1	0	0	0	1	0	1	0	0	0	0	0	0	1	1	0	0	0	0	0	0	0	0	0	0	0	0	0	0	1	0	0	0	1	0	
▼	▼	▼	▼	▼	▼	▼	▼	▼	▼	▼	▼	▼	▼	▼	▼	▼	▼	▼	▼	▼	▼	▼	▼	▼	▼	▼	▼	▼	▼	▼	▼	▼	▼	▼	▼	▼	▼
3	3	2	2	2	2	2	2	2	2	2	2	1	1	1	1	1	1	1	1	1	1	1	1	1	1	1	1	1	1	1	1	1	1	1	1	1	
1	0	9	8	7	6	5	4	3	2	1	0	9	8	7	6	5	4	3	2	1	0	9	8	7	6	5	4	3	2	1	0	9	8	7	6		
Bit numbers																																					

[Table 16](#) on page 73 contains a list of the lower 16 status flags that will be useful for fault finding. The upper 16 status flags are reserved by Edwards.

Table 16 Status flag

Bit number	Status flag	Active flags mean
0	Fail	Fail status condition active
1	Stopped speed	Below stopped speed
2	Normal speed	Above normal speed

Bit number	Status flag	Active flags mean
3	Vent valve closed	Vent valve energised / de-energised according to the valve type option
4	Start	Start command active
5	Serial enable	Serial command active
6	Standby	Standby active
7	Half full speed	Above 50% full rotational speed
8	Parallel control mode	Exclusive control mode selection
9	Serial control mode	Exclusive control mode selection
10	Invalid Controller software	Controller internal software mismatch
11	Controller upload incomplete	Controller failed internal configuration and calibration operation
12	Timer expired	Failure to reach or maintain half full speed within the timer setting value
13	Hardware trip	Overspeed or overcurrent trip activated
14	Thermistor error	Pump internal temperature measurement system disconnected or damaged
15	Serial control mode interlock	Serial enable has become inactive following a serial Start command

The system status word used in the example above was obtained with the pump at rest. By decoding the word, we can learn more about the state of the pump.

Table 17 Example decoding of system status words

Bit number	Status of bit (in example)	We can deduce
0	0	The pump has not failed
1	1	The pump is at rest
2	0	Speed is below normal speed
3	0	The vent valve is open
4	0	There is no active start command
5	1	Serial enable is active
6	0	Standby is not active
7	0	Speed is below 50% of full rotational speed
8	0	The pump is not in parallel control mode
9	0	The pump is not in serial control mode
10	0	There is no controller internal software mismatch
11	0	Controller passed internal configuration and calibration operation
12	0	The timer has not timed out

Bit number	Status of bit (in example)	We can deduce
13	0	Overspeed and overcurrent trip not activated
14	0	Pump internal temperature measurement system is fine
15	0	Serial enable has not become inactive during serial control

Service information

When using the serial communications link, additional information about the pump, such as pump type and internal controller software versions, can be accessed. This information is particularly useful for service personnel to determine the model of the pump.

Send the following query to find out pump type:

Command	?	S	8	5	1	cr													
---------	---	---	---	---	---	----	--	--	--	--	--	--	--	--	--	--	--	--	--

The reply will be as follows, where string 1 is the pump type, string 2 is the DSP software version number and string 3 is the designated full speed of the pump (in revolutions per second):

Reply	=	S	8	5	1	sp	String 1	;	String 2	;	String 3	cr							
-------	---	---	---	---	---	----	-------------	---	-------------	---	-------------	----	--	--	--	--	--	--	--

Send the following query to find out the boot loader software version:

Command	?	S	8	6	8	cr													
---------	---	---	---	---	---	----	--	--	--	--	--	--	--	--	--	--	--	--	--

The reply will be as follows, where string1 is the boot loader software version number:

Reply	=	S	8	6	8	sp	String 1	cr											
-------	---	---	---	---	---	----	-------------	----	--	--	--	--	--	--	--	--	--	--	--

Service

Note:

Our policy is to provide support for product after obsolescence through various options including maintenance, repair, enhancement and replacement. Support will be available for several years after product obsolescence and in compliance with any applicable legislation. We will always undertake appropriate actions to ensure support is maintained and, where support is no longer possible, will ensure this is communicated to all affected customers with a suitable notice period.

Our products, spares and accessories are available from Edwards companies in Belgium, Brazil, China, France, Germany, Israel, Italy, Japan, Korea, Singapore, United Kingdom, U.S.A and a world-wide network of distributors. The majority of these centres employ Service Engineers who have undergone comprehensive Edwards training courses.

Order spare parts and accessories from the our nearest company or distributor. When ordering, state for each part required:

- Model and Item Number of the equipment
- Serial number
- Item Number and description of part.

Our products are supported by a world-wide network of Edwards Service Centres. Each Service Centre offers a wide range of options including: equipment decontamination; service exchange; repair; rebuild and testing to factory specifications. Equipment which has been serviced, repaired or rebuilt is returned with a full warranty.

Local Service Centres can also provide qualified engineers to support on-site maintenance, service or repair of equipment. For more information about service options, contact us or the nearest Service Centre.

Returning a pump for service

When returning a pump to a Service Centre, use the returns procedures in the HS1 form.

Follow the procedure in [Figure 24](#) on page 108 and ensure that a completed [Figure 25](#) on page 109 form is returned with the pump.

The instruction in the returns procedure to drain all fluids does not apply to the lubricant in the pump oil reservoirs. Do not return the pump with the accessories fitted. Remove all accessories and retain them for future use.

If the pump is configured to suit the application, make a record of the configuration before returning the pump. All replacement pumps will be supplied with default factory settings. The TIC/nEXT PC monitor program (available as an accessory) allows for automatic downloading and saving the configuration.

Bearing and oil cartridge on-site maintenance

The oil cartridge and bearing of the pump can be serviced on-site by any service engineer trained by Edwards.

Service tool kits and service parts are available:

Table 18 Service tool kits

Service tool kit	Item Number
Bearing exchange tooling kit	B8G200845

Table 19 Service kits

Service kit	Item number
Oil cartridge	B8G200828
Bearing and oil cartridge	B8G200811

 **Note:**

Both the oil cartridge and bearing kits are required when changing a pump bearing. Please refer to the Bearing Service Tool Kit instruction manual B8G200840 for details on how to service the oil cartridge and bearing.

Spares



CAUTION:

Use of spares, not supplied by us, may result in reduced reliability and performance and will invalidate product warranty.

<i>Inlet screen</i>	Inlet screens are fitted to the pumps as supplied to prevent damage from the entry of debris into the pump.
<i>Inlet strainer</i>	The interstage pumps are supplied with an inlet strainer for the interstage port.
<i>Inlet flange seals and integrated inlet screens</i>	The pumps are supplied with an inlet seal.
<i>NW16 and NW25 ports</i>	The pumps are supplied with a NW16 backing port and either a NW16 or NW25 interstage port.

Inlet screen

Inlet screens are fitted to the pumps as supplied to prevent damage from the entry of debris into the pump.

Table 20 Inlet screens

Flange size	Item number
DN63CF (10 off kit)	B72240807
DN63CF (1 off kit)	B72240860

Inlet strainer

The interstage pumps are supplied with an inlet strainer for the interstage port.

Table 21 Inlet strainers

Flange size	Item number
DN25ISO-K	A22305067

Inlet flange seals and integrated inlet screens

The pumps are supplied with an inlet seal.

Table 22 Inlet flange seals and integrated inlet screens

Flange size	Inlet flange seal	Item number
DN100ISO-K	ISO100 trapped O-ring with integrated coarse inlet screen	B81000808
DN100ISO-K	ISO100 trapped O-ring with integrated fine inlet screen	B81000809
DN63ISO-K	ISO63 trapped O-ring with integrated coarse inlet screen	B8G200808

Flange size	Inlet flange seal	Item number
DN63ISO-K	ISO63 trapped O-ring with integrated fine inlet screen	B8G200809
NW40	NW40 centring o-ring with integrated coarse inlet screen	C10516085

NW16 and NW25 ports

The pumps are supplied with a NW16 backing port and either a NW16 or NW25 interstage port.

Table 23 Inlet strainers

Port	Item number
NW16	B80000806
NW25	B80000809

Accessories for the nEXT85

<i>Air cooler</i>	The air coolers are available with a pre-wired connector which connects directly to an auxiliary port on the controller or with a bare wire.
<i>Water cooler</i>	A water cooler can be fitted to the pump if the water supply is suitable..
<i>Flange heater</i>	A nEXT85 flange heater accelerates the degassing of the pump to enable it to achieve lower pressures. It may also be used to protect the pump from condensation of contaminants.
<i>TAV5 vent valve</i>	24 V d.c. TAV5 solenoid-operated vent valve options available for system venting; these are either normally open (N/O) or normally closed (N/C).
<i>VRX vent restrictor</i>	Use a VRX fixed orifice vent restrictor to restrict the flow of vent gas into the pump.
<i>Vent port adaptor</i>	The vent port adaptor has a 1/8 inch BSP male thread that can be screwed into both the vent port and purge port, making them suitable for NW10 fittings.
<i>PRX purge restrictor</i>	The PRX10 is a modified DN10NW centring ring that filters the purge gas and restricts its flow rate to the recommended flow of 25 sccm. A vent port adaptor must be fitted to the purge port in order to connect a purge restrictor to the pump.
<i>Interface cable</i>	An interface cable connects the nEXT85 pump to a PC. Serial commands are then used to control and monitor the nEXT85 pump.
<i>nST PC program</i>	The nST PC program is PC-based software that can be used with the nEXT85 pump either via the serial interface or via the USB service port.
<i>Auxiliary connector</i>	Enables the use of accessories that do not come prewired with a mating plug. Cable length is 1.5 m.
<i>Auxiliary extension cable</i>	The cable extends the distance of the accessory to the pump and benefits from a right angled plug to accommodate installation where space is limited. Cable length is 0.2 m.
<i>Auxiliary 'Y' cable adaptor</i>	Enables either a TAV5 vent valve and a cooling fan or two cooling fans or 2 TAV5 vent valves to be operated at the same time. The two sockets of the Y-cable are wired in parallel so either connector can be used in exactly the same way as the auxiliary connector on the pump itself.
<i>Base mounting adaptor</i>	A base mounted adaptor is available to enable the nEXT85 pump to be mounted in the same position as an EXT75DX pump.

Figure 10 Accessories

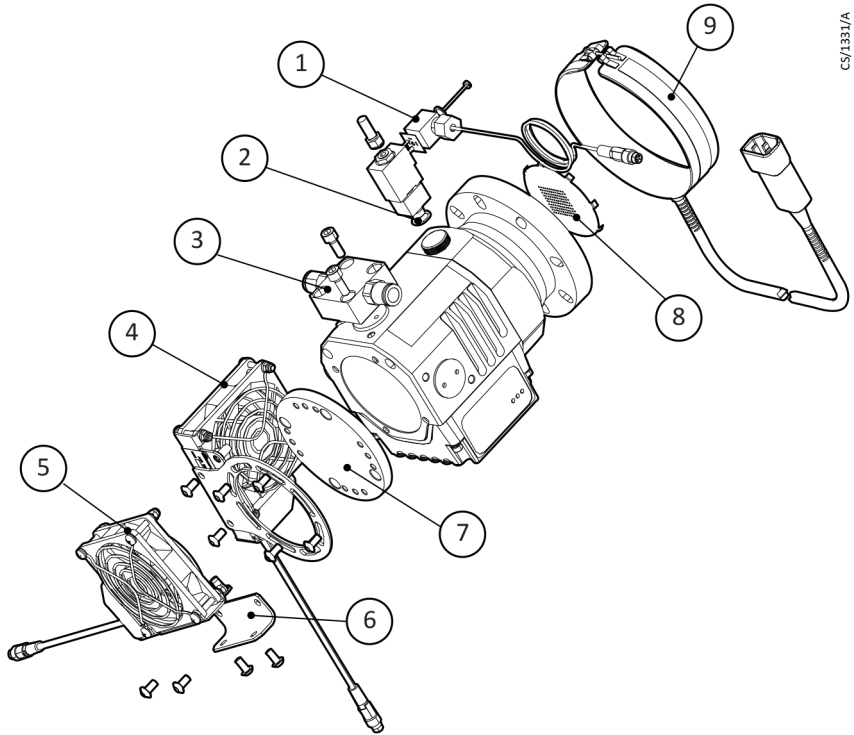

- | | |
|-------------------------------|--|
| 1. TAV Solenoid vent-valve | 6. ACX85 Axial air cooler mounting bracket |
| 2. Manual vent-valve (fitted) | 7. Base mounting adaptor |
| 3. nEXT85 water cooler | 8. Inlet screen (CF63 shown) |
| 4. ACX85 Radial air cooler | 9. Flange heater |
| 5. ACX85 Axial air cooler | |

Air cooler

The air coolers are available with a pre-wired connector which connects directly to an auxiliary port on the controller or with a bare wire.

A choice of air coolers can be fitted to the pump - refer to [Forced air cooling](#) on page 34 to check the suitability of air cooling in a particular application. The air coolers are pre-wired to Vent Option 2 and the default is set to Always On (option 8).

Table 24 Air cooler

Item	Current draw	Item number
nEXT85 Air cooler kit - wired	150 mA	B8G200820
nEXT85 Air cooler kit - bare wire	150 mA	B8G200821

Water cooler

A water cooler can be fitted to the pump if the water supply is suitable..

Refer to [Forced air cooling](#) on page 34 to check the suitability of the water cooling supply.

Table 25 Water cooler

Item	Item number
nEXT85 water cooler	B8G200833

Flange heater

A nEXT85 flange heater accelerates the degassing of the pump to enable it to achieve lower pressures. It may also be used to protect the pump from condensation of contaminants. The flange heaters are available in 110 V and 240 V versions.

 **Note:**

The flange heater is only for use with CF variants.

Table 26 Flange heater

Item	Item number
nEXT85 (110 V) flange heater	B8G200823
nEXT85 (240 V) flange heater	B8G200824

TAV5 vent valve

24 V d.c. TAV5 solenoid-operated vent valve options available for system venting; these are either normally open (N/O) or normally closed (N/C).

Both valves are available with either a wired connector which connects directly to the auxiliary port on the controller or as a bare wire option.

All vent valves have an 0.5 mm diameter orifice and are suitable for venting small vacuum systems of <5 litres.

The vent valves are pre-wired to Vent Option 1 and that the default is set to fully vent at 50% (option 0). The solenoid valve is fitted in place of the manual valve, or alternatively can be fitted with an adaptor (supplied with the valve) and be used with any suitable NW10 flanged port on the vacuum system. The vent port adaptor allows the vent port or the purge port to be used with any suitable NW10 fitting.

Table 27 TAV5 vent valve and vent port adaptor

Item	Item number
nEXT85 TAV5 kit N/C connector fitted (0.3 m)	B8G200835
nEXT85 TAV5 kit N/C bare wire (3 m)	B58066040
nEXT85 TAV5 kit N/O connector fitted (0.3 m)	B8G200834
nEXT85 TAV5 kit N/O bare wire(3 m)	B58066010

VRX vent restrictor

Use a VRX fixed orifice vent restrictor to restrict the flow of vent gas into the pump.

Table 28 VRX vent restrictor

Vent restrictor	Orifice diameter	Item number
VRX10	0.1 mm	B58066021
VRX20	0.2 mm	B58066022
VRX30	0.3 mm	B58066023
VRX50	0.5 mm	B58066024
VRX70	0.7 mm	B58066025

Vent port adaptor

The vent port adaptor has a 1/8 inch BSP male thread that can be screwed into both the vent port and purge port, making them suitable for NW10 fittings.

Table 29 Vent port adaptor

Item	Item number
Vent port adaptor NW10 - 1/8 inch BSP male	B58066011

PRX purge restrictor

The PRX10 is a modified DN10NW centring ring that filters the purge gas and restricts its flow rate to the recommended flow of 25 sccm. A vent port adaptor must be fitted to the purge port in order to connect a purge restrictor to the pump.

Table 30 PRX purge restrictor

Item	Item number
PRX10 purge restrictor	B58065001

Interface cable

An interface cable connects the nEXT85 pump to a PC. Serial commands are then used to control and monitor the nEXT85 pump.

Table 31 Interface cable

Item	Item number
nEXT interface cable	B80000808

nST PC program

The nST PC program is PC-based software that can be used with the nEXT85 pump either via the serial interface or via the USB service port.

It can be used to control, monitor, configure and data log the nEXT85 pump, and also to view service status, reset service intervals and upgrade the software embedded in the motor controller.

This software is available for download from the Edwards upgrades website:
www.upgrades.edwardsvacuum.com

Currently, nST software requires a free license in order to be used. To obtain a free license please follow the onscreen instructions, fill out the user data form and then send the automatically generated email to Edwards.

Auxiliary connector

Enables the use of accessories that do not come prewired with a mating plug. Cable length is 1.5 m.



Table 32 Auxiliary connector

Item	Item number
nEXT85 auxiliary connector	B8G200839

Auxiliary extension cable

The cable extends the distance of the accessory to the pump and benefits from a right angled plug to accommodate installation where space is limited. Cable length is 0.2 m.



Table 33 Auxiliary extension cable

Item	Item number
nEXT85 auxiliary extension cable	B8G200836

Auxiliary 'Y' cable adaptor

Enables either a TAV5 vent valve and a cooling fan or two cooling fans or 2 TAV5 vent valves to be operated at the same time. The two sockets of the Y-cable are wired in parallel so either connector can be used in exactly the same way as the auxiliary connector on the pump itself.



Table 34 Auxiliary 'Y' cable adaptor

Item	Item number
nEXT85 auxiliary 'Y' cable adaptor	B8G200837

Base mounting adaptor

A base mounted adaptor is available to enable the nEXT85 pump to be mounted in the same position as an EXT75DX pump.

Table 35 Base mounting adaptor

Item	Item number
nEXT85 base mounting adaptor	B8G200838

Technical Reference

Operating and storage conditions

Table 36 Operating and storage conditions

Range	Data
Ambient operating temperature range	5 °C to 40 °C
Ambient operating humidity range	10 to 90% RH (non-condensing)
Maximum operating altitude	2000 m
Ambient storage temperature range	-30 °C to 70 °C

General technical data

Table 37 General technical data

General items	Reference data
Dimensions	Refer to Figure 11 on page 86, Figure 12 on page 87, Figure 13 on page 87 and Figure 14 on page 87
Maximum inlet flange temperature	120 °C
Pollution degree	61010-1 Pollution degree 2
Maximum external magnetic field	5 mT Radial (for standard aluminium envelope pump)
Equipment type	Fixed equipment, for indoor use only
Enclosure protection (installed)	IP64
Power supply	24 - 48 V d.c. (Refer to Electrical data on page 95 for additional information)

Figure 11 Dimensions - nEXT85 ISO63

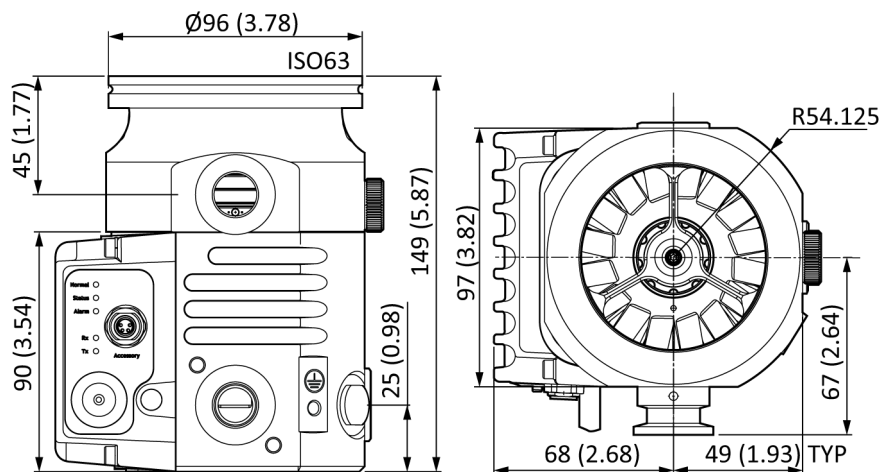

All measurements indicated are shown in mm (inches)

Figure 12 Dimensions - nEXT85 CF63

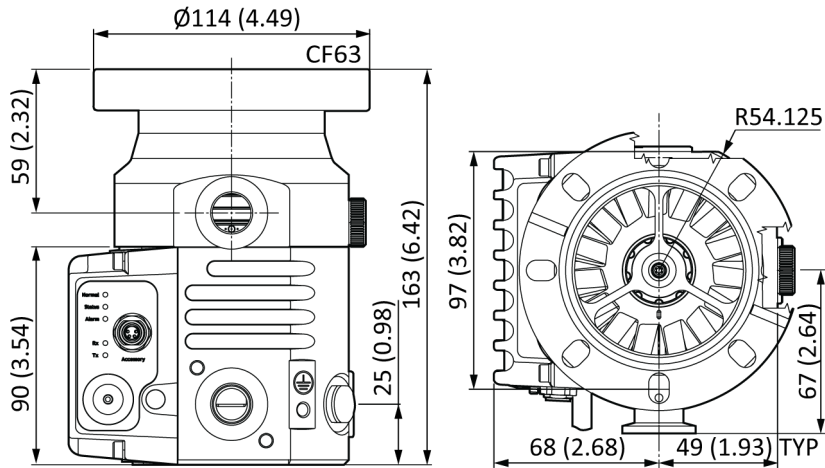

All measurements indicated are shown in mm (inches)

Figure 13 Dimensions - nEXT85 ISO100

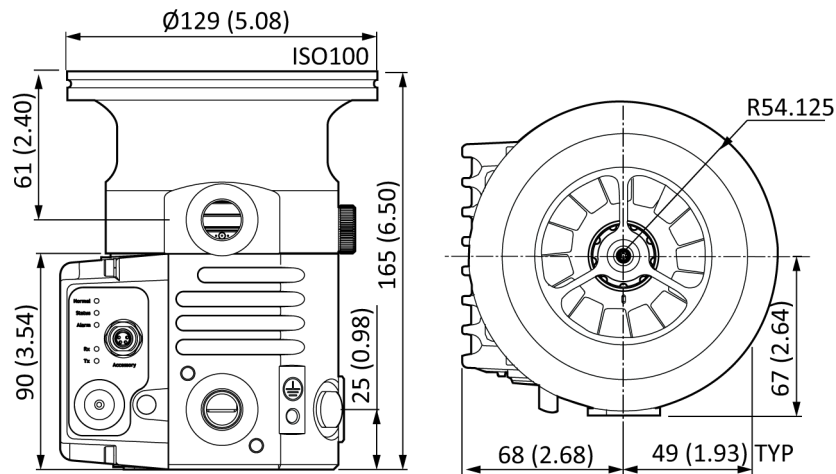

All measurements indicated are shown in mm (inches)

Figure 14 Dimensions - nEXT85 DN40

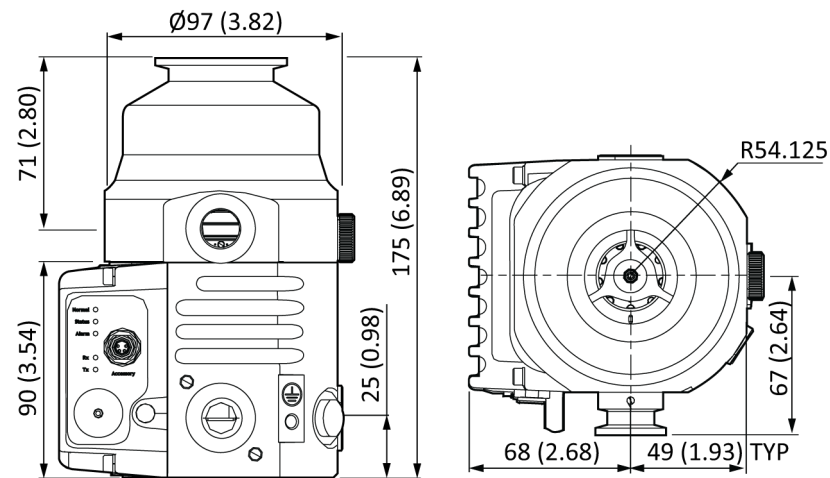

All measurements indicated are shown in mm (inches)

Figure 15 Typical base view

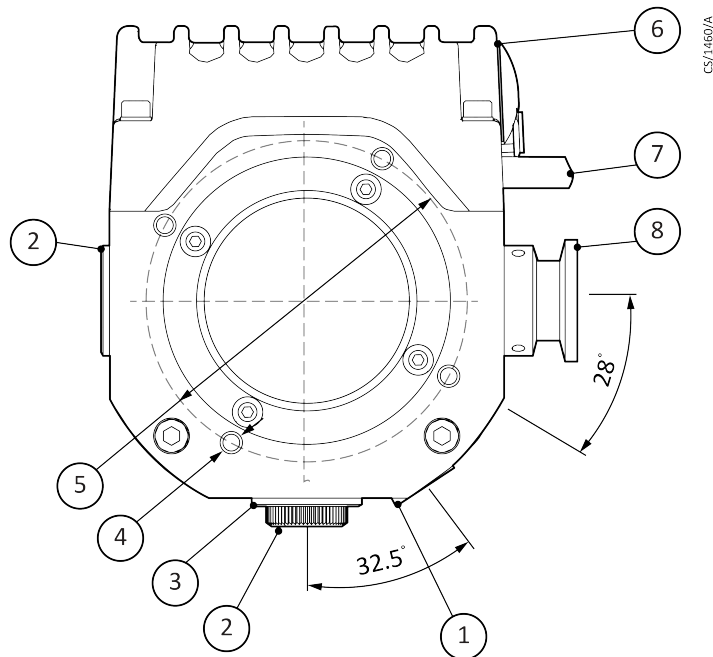

- | | |
|---|--------------------------------------|
| 1. Body purge port 1/8" BSP | 5. 79 PCD mounting port |
| 2. Envelope vent port 1/8" BSP | 6. Electric drive |
| 3. Alternative backing port position | 7. 24V supply cable |
| 4. 4 x holes (M5 x 12 deep) Base mounting holes and fan mountings | 8. Backing port NW16 (Optional NW25) |

Pump performance data

Table 38 Pump performance data

Parameter	nEXT85D	nEXT85H	nEXT85D	nEXT85H	nEXT85D	nEXT85H	nEXT85D	nEXT85H
Mass	3.0 Kg	3.0 Kg	4.4 Kg	4.4 Kg	3.2 Kg	3.2 Kg	2.9 Kg	2.9 Kg
Main inlet port	ISO63	ISO63	CF63	CF63	ISO100	ISO100	NW40	NW40
Exhaust port	NW16	NW16	NW16	NW16	NW16	NW16	NW16	NW16
Vent port	1/8 inch BSP	1/8 inch BSP	1/8 inch BSP	1/8 inch BSP	1/8 inch BSP	1/8 inch BSP	1/8 inch BSP	1/8 inch BSP
Main inlet pumping speed:								
N ₂ (l s ⁻¹)	84	84	84	84	86	86	47	47
He (l s ⁻¹)	78	78	78	78	80	78	61	61
H ₂ (l s ⁻¹)	60	54	60	54	60	54	49	49
Ar (l s ⁻¹)	80	80	80	80	84	84	44	44
Peak compression ratio from the backing port to the main inlet port:								
N ₂	> 10 ¹¹	> 10 ¹¹	> 10 ¹¹	> 10 ¹¹	> 10 ¹¹	> 10 ¹¹	> 10 ¹¹	> 10 ¹¹
He	8x10 ⁶	2x10 ⁷	8x10 ⁶	2x10 ⁷	8x10 ⁶	2x10 ⁷	8x10 ⁶	2x10 ⁷

Parameter	nEXT85D	nEXT85H	nEXT85D	nEXT85H	nEXT85D	nEXT85H	nEXT85D	nEXT85H
H ₂	2x10 ⁵	5x10 ⁵	2x10 ⁵	5x10 ⁵	2x10 ⁵	5x10 ⁵	2x10 ⁵	5x10 ⁵
Ar	> 10 ¹¹	> 10 ¹¹	> 10 ¹¹	> 10 ¹¹	> 10 ¹¹	> 10 ¹¹	> 10 ¹¹	> 10 ¹¹
Ultimate pressure (mbar)	< 5x10 ⁻⁹	< 5x10 ⁻⁹	< 5x10 ⁻¹⁰	< 5x10 ⁻¹⁰	< 5x10 ⁻⁹	< 5x10 ⁻⁹	< 5x10 ⁻⁹	< 5x10 ⁻⁹

Note:

Pumping speeds quoted are without inlet screens. Inlet screens may reduce the pumping speed by up to 20%. Pumping speeds are measured in accordance with ISO 5302:2003.

Figure 16 nEXT85 pumping speed versus inlet pressure performance graph

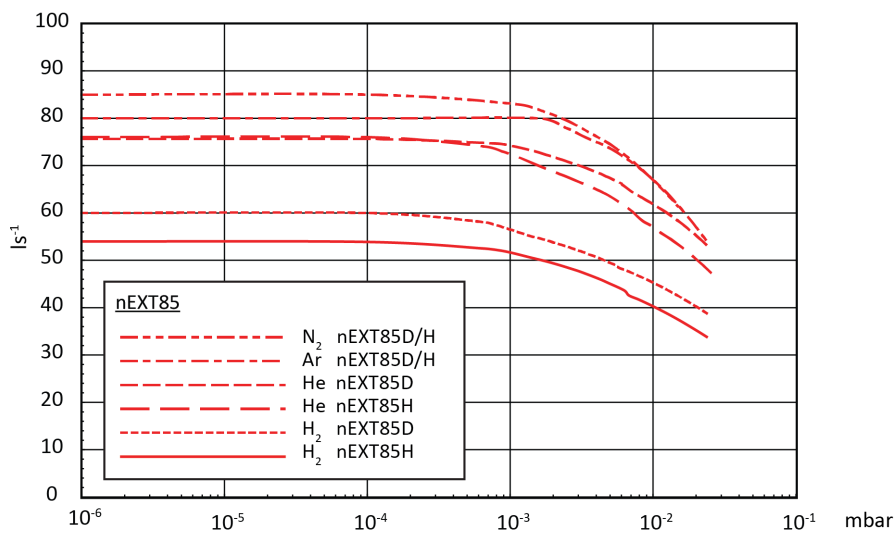

Figure 17 nEXT85 compression ratio versus backing pressure graph

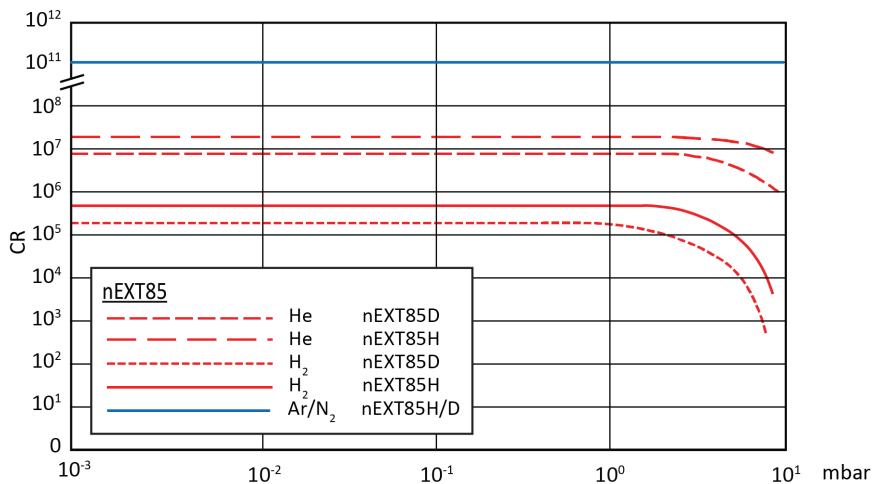

Table 39 Maximum transient backing pressure at zero inlet flow

Parameter	nEXT85D	nEXT85H
N ₂	19 mbar	21 mbar
He	19 mbar	21 mbar

Parameter	nEXT85D	nEXT85H
H ₂	30 mbar	30 mbar
Ar	22 mbar	21 mbar

Maximum transient backing pressure is that which can be sustained for a short time period at 120 W.

Table 40 Maximum continuous backing pressure nEXT85D at zero inlet flow

Gas Type: N ₂			
Cooling method	Ambient Temperature		
	20 °C	30 °C	40 °C
	Backing Pressure (mbar)	Backing Pressure (mbar)	Backing Pressure (mbar)
Natural convection	6	3.2	0.6
Force air cooling	18	14	11
Water cooling *	13	11.5	10

* Cooling water temperature of 15 °C at a flow rate of 15 l hr⁻¹

Values for maximum continuous backing pressure are obtained under no inlet gas flow conditions, at sea level, negligible magnetic field, with 120 W power limit setting.

Refer to [Cooling](#) on page 33 for cooling conditions. Above these pressures, rotational speed drops below nominal.

Table 41 Maximum continuous inlet pressure/throughput nEXT85D - Nitrogen

Gas Type: N ₂						
Cooling method	Ambient Temperature					
			30 °C		40 °C	
	Throughput (sccm)	Inlet Pressure (mbar)	Throughput (sccm)	Inlet Pressure (mbar)	Throughput (sccm)	Inlet Pressure (mbar)
Natural convection	15	3.6e-03	12	2.9e-03	7	1.6e-03
Force air cooling	95/80 *	3.8e-02/ 2.9e-02 *	72	2.5e-02	37	1.0e-02
Water cooling §	50	1.5e-02	45	1.3e-02	40	1.1e-02

* Based on 80 W power limit setting

§ Cooling water temperature of 15 °C at a flow rate of 15 l hr⁻¹

Values for maximum continuous inlet pressure/throughput are obtained using an nXDS20i backing pump, at sea level, in negligible magnetic field, with 120 W power limit setting.

Refer to [Cooling](#) on page 33 for cooling conditions. Above these pressures, rotational speed drops below nominal. Values are quoted without inlet screen.

Table 42 Maximum continuous inlet pressure/throughput nEXT85D - Helium

Gas Type: He						
Cooling method	Ambient Temperature					
	20 °C		30 °C		40 °C	
	Throughput (sccm)	Inlet Pressure (mbar)	Throughput (sccm)	Inlet Pressure (mbar)	Throughput (sccm)	Inlet Pressure (mbar)
Natural convection	90	3.5e-02	60	2.0e-02	20	5.6e-03
Force air cooling	510/240 *	5.3e-01/ 1.5e-01*	475/240*	4.6e-01/ 1.5e-01*	235	1.5e-01
Water cooling §	270/240*	1.9e-01/ 1.5e-01*	200	1.1e-01	130	6.0e-02

* Based on 80 W power limit setting

§ Cooling water temperature of 15 °C at a flow rate of 15 l hr⁻¹

Values for maximum continuous inlet pressure/throughput are obtained using an nXDS20i backing pump, at sea level, in negligible magnetic field, with 120 W power limit setting.

Refer to [Cooling](#) on page 33 for cooling conditions. Above these pressures, rotational speed drops below nominal. Values are quoted without inlet screen.

Table 43 Maximum continuous inlet pressure/throughput nEXT85D - Argon

Gas Type: Ar						
Cooling method	Ambient Temperature					
	20 °C		30 °C		40 °C	
	Throughput (sccm)	Inlet Pressure (mbar)	Throughput (sccm)	Inlet Pressure (mbar)	Throughput (sccm)	Inlet Pressure (mbar)
Natural convection	6.5	1.6e-03	5	1.2e-03	3	7.2e-04
Force air cooling	35	9.4e-03	25	6.4e-03	13	3.2e-03
Water cooling *	20	5.0e-03	18	4.5e-03	15	3.7e-03

* Cooling water temperature of 15 °C at a flow rate of 15 l hr⁻¹

Values for maximum continuous inlet pressure/throughput are obtained using an nXDS20i backing pump, at sea level, in negligible magnetic field, with 120 W power limit setting.

Refer to [Cooling](#) on page 33 for cooling conditions. Above these pressures, rotational speed drops below nominal. Values are quoted without inlet screen.

Table 44 General pump performance data

Parameter	Value
Recommended backing pump	nXDS15i
Operation attitude	Vertical and upright to horizontal $\pm 2^\circ$
Normal rotational speed	90,000 revolutions per minute
Starting Time to 90% Speed (80 W)	130 seconds
Starting Time to 90% Speed (120 W)	90 seconds
Sound pressure level, at ultimate vacuum measured at 1 m from the pump to ISO3744	34 dB(A) + 2.5 declared dual number noise emission values in accordance with ISO4871

Pumped media



WARNING:

Vent dangerous gases and gas mixtures safely. Do not expose people to these gases. If pumping hazardous gases or vapours, observe the safety recommendations of the supplier of the gas/vapour.



WARNING:

Do not use the pump to pump pyrophoric or explosive gas mixtures as it is not suitable for this purpose. The pump and its connections are not designed to contain an explosion.



WARNING:

In the interstage version of the pumps, gas pumped through the interstage port will mix with gas pumped through the pump inlet. Ensure that the gases will not react or combine to form dangerous gases and substances.



WARNING:

Do not expose any part of the human body to the vacuum as this could result in injury to or death of people.



WARNING:

Do not use the pump to pump mercury vapour and do not allow mercury (for example, from a McLeod gauge) to come into contact with the pump. This may result in corrosion and failure of the pump rotor.



CAUTION:

Do not use the pump to pump particulates or condensable media. Deposition may occur within the pump which will degrade pump performance and reduce the pump life.

**CAUTION:**

Do not use the pump to pump gases containing more than 20% oxygen. This will cause the lubricant to polymerise and the pump to fail prematurely.

 **Note:**

Concentrations of gases may be modified by the compression of the pump.

The pump is designed to pump the gases listed below. To pump a gas not listed, contact the supplier for advice. Failure to contact the supplier may invalidate the warranty of the pump. The pump is not suitable for pumping aggressive or corrosive gases.

Refer to the Edwards Vacuum Pump and Vacuum Safety manual P400-40-100 for safety information associated with the specification, design and operation of vacuum pumps and vacuum systems.

- Air
- Carbon monoxide
- Neon
- Nitrogen
- Krypton
- Argon
- Carbon dioxide
- Helium
- Hydrogen

The pump can be used to pump oxygen and water vapour, subject to the following conditions:

- Oxygen - The oxygen concentration must be less than 25% by volume.
- Water vapour - Ensure that vapour does not condense inside the pump.

Venting gas specification and vent control data

Although the pump may be vented to atmosphere, high relative humidity of the air may greatly increase the subsequent pump-down time. To reduce pump-down times the pump should be vented with dry, clean gases. Refer to [Vent options, vent valve connection and control](#) on page 47 for a description of the vent options and the vent valve connection. Refer to Section [Controlled venting options](#) on page 39 for configuring the venting options.

Table 45 Vent gas specification and vent control

Vent gas specification and control	Reference data
Vent gas	Dry air, nitrogen, argon or other inert gases
Maximum dew point at atmospheric pressure	-22 °C
Maximum size of particulates	1 µm
Maximum concentration of oil	0.1 parts per million
Recommended time for rotational speed to reach 50%	> 15 seconds
Maximum allowed rate of pressure rise	Refer to Figure 18 on page 94
Maximum allowable vent gas supply pressure	1 bar (gauge); 14.5 psig, 2 x 10 ⁵ Pa

Figure 18 Max allowed rate of pressure rise during venting: pressure against time (pump initially at full speed)

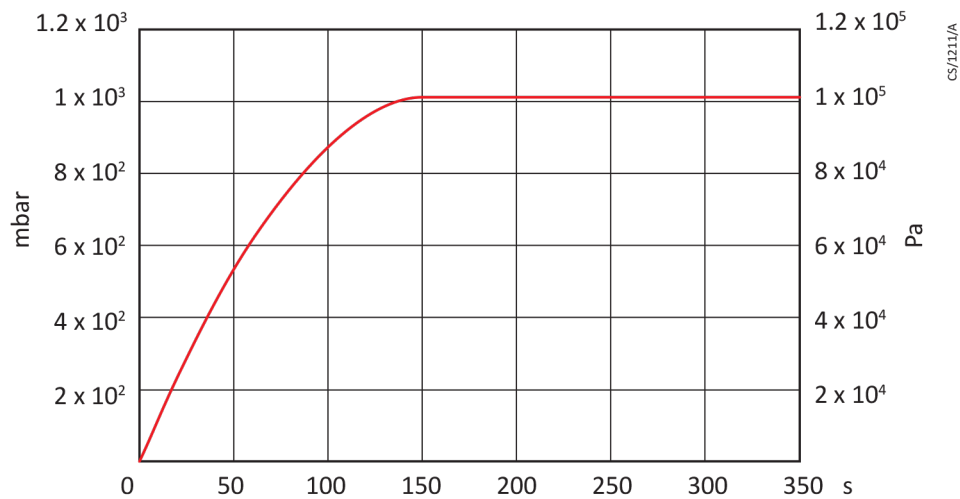

Materials exposed to gases pumped

The following materials and component types are exposed to the gases pumped:

- aluminium alloys
- steels
- stainless steels
- fluoroelastomer and O-rings
- hydrocarbon lubricant
- felt
- rare earth magnets
- silicon nitride
- titanium
- PTFE

Purge gas specification

Table 46 Purge gas specification

Purge gas specification	Reference data
Purge gas	Dry air, nitrogen, argon or other inert gases
Maximum dew point at atmospheric pressure	-22 °C
Maximum size of particulates	1 µm
Maximum concentration of oil allowable	0.1 parts per million
Purge gas flow (when required)	20 to 50 sccm (0.33 to 0.84 mbar l s ⁻¹ or 33 to 84 Pa l s ⁻¹)
Recommended purge gas flow	25 sccm (0.42 mbar l s ⁻¹ , 42 Pa l s ⁻¹)
Maximum allowable purge gas supply pressure	1 bar (gauge); 14.5 psig, 2 x 10 ⁵ Pa

Water cooling

Table 47 Water cooling block supply requirements

Parameter	Specification
Quality	Mechanically and optically clean with no deposits or turbidity
pH Value	6.0 to 8.0
Maximum calcium carbonate concentration	75 parts per million
Maximum chloride concentration	100 parts per million
Minimum oxygen concentration	4 parts per million
Minimum water-cooling flow rate (at 15 °C)	15 l h ⁻¹
Water temperature range	10 °C to 40 °C
Maximum water pressure	5 bar (gauge), 72.5 psig, 5 x 10 ⁵ Pa gauge
Materials exposed to cooling water	Nickel plated brass

Figure 19 Maximum relative humidity to avoid condensation with water cooling

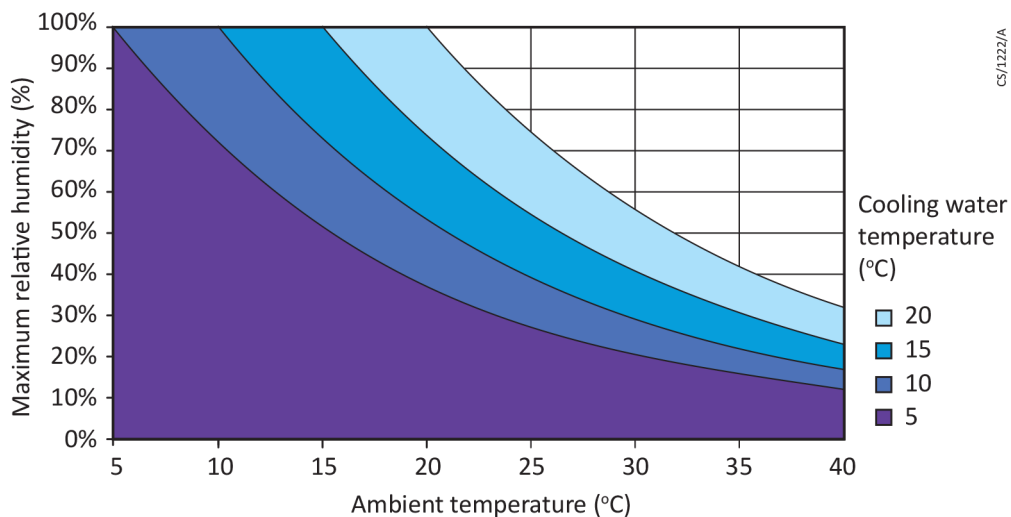

Electrical data

The nEXT85 pumps can be driven by either the customers system or by the Edwards TIC Turbo Instrument Controller, TIC Turbo Controller or TAG Controller.

If using the customer system, an appropriate, pre-approved, UL/CSA rated 24 - 48 V d.c. power supply should be used. The size of the power supply required depends on the application and the power limit configured in the nEXT85 pump. The power limit setting determines how quickly the pump ramps up and dictates the size of the power supply required. If serial communications is available, the power limit setting of the nEXT85 pump can be selected. Refer to [Table 48](#) on page 96 for the maximum power limit settings for nEXT85 pumps. If the application requires rapid cycling of the pump, faster ramp times can be achieved if the power supply delivers higher current, up to a maximum in accordance with [Table 48](#) on page 96.

If the facility to adjust the power limit setting is not available, use a power supply capable of delivering enough current to meet the Edwards factory default power limit setting, shown in [Table 48](#) on page 96.

Logic interface connector

nEXT85 pumps have a 15-way logic interface connector on the end of the logic interface cable. Use a suitable connector mating half (not supplied) to connect the nEXT85 pump to the customer equipment. Refer to the following table for the connector mating half type.

Table 48 Logic interface technical data

Logic interface items	
Connector *	15-way D-type male
nEXT85 pumps electrical supply:	
Allowable voltage range (including any ripple)	24 V d.c. to 48 V d.c. +5%, -10% (21.6 V d.c. to 50.4 V d.c.)
Maximum voltage ripple	0.5 V rms
Fuse rating	T6ALxxxV to T10ALxxxV for 24 V d.c. supply T4ALxxxV to T10ALxxxV for 48 V d.c. supply Use an IEC/UL/CSA pre-approved fuse rated ≥ 60 V d.c.
Limit of power drawn from supply:	
Factory default setting	Refer to pump model on product label
Maximum setting	120 W
Minimum setting	50 W
Accuracy of power regulation	± 10 W
Start and serial enable control inputs:	
Enabled control voltage: low (close)	0 to 0.8 V d.c. ($I_{out} = 0.55$ mA nominal)
Disabled control voltage: high (open)	4 to 26.4 V d.c. (internal pull up to 6.4 V nominal)
Standby control input:	
Enabled control voltage: low (close)	0 to 0.8 V d.c. ($I_{out} = 0.29$ mA nominal)
Disabled control voltage: high (open)	4 to 26.4 V d.c. (internal pull up to 3.2 V nominal)
Analogue output:	
Output voltage	0 to 10 V d.c. (directly proportional to measured parameter) Motor speed: 0 - 1500 Hz (0-100%) Input power: 0 - 120 W Motor temperature: 0 - 100 °C Controller temperature: 0 - 100 °C Rotor temperature: 0 - 100 °C
Voltage accuracy	± 0.2 V
Output current	≤ 5 mA for specified accuracy
NORMAL status output:	

Logic interface items	
Type	Open collector transistor plus pull up resistor. Refer to Figure 20 on page 98
< Normal speed (default 80%)	Off (2.2 kΩ internal pull up to 12 V d.c.)
≥ Normal speed	On (< 0.8 V d.c. sinking 20 mA)
Current rating	20 mA to 0 V
Voltage rating	28.8 V d.c. maximum external pull up voltage
FAIL status output:	
Type	Open collector transistor plus pull up resistor. Refer to Figure 20 on page 98
Fail	Off (3.3 kΩ internal pull up to 12 V d.c.)
OK	On (< 0.1 V d.c. sinking 1.7 mA, < 0.8 V d.c. sinking 20 mA)
Current rating	20 mA to 0 V
Voltage rating	28.8 V d.c. maximum external pull up voltage

* Mating half of connector not supplied.

Refer to the following table for Logic Interface connector pins for the electrical connections.

Table 49 Logic interface connector pins

Pin number	Signal	Polarity	Use
2	0 V Control reference	-	0 V reference for all control and status signals below.
3	START/STOP control input	-	Connect to Pin 2 to start pump.
4	STANDBY control input / Serial RX/ RS485 A-	-	Connect to Pin 2 to enable standby speed when serial enable is inactive and RS485/RS232 switch is in the RS232 position.
5	Serial enable	-	Connect to Pin 2 to enable the serial link.
7	FAIL / Serial TX/RS485 B+	-	Logic high when fail condition exists and serial enable is inactive and RS485/RS232 switch is in the RS232 position.
9	Analogue output	Positive	0 - 10 V output proportional to measured output.
10	Chassis / Screen	-	Screen
12	Chassis / Screen	-	-
15	NORMAL status output	-	Logic low when pump rotational speed is at normal speed or above
8, 13, 14	Electrical supply: 0 V	-	-
1, 6, 11	Electrical supply: 24 - 48 V d.c.	Positive	-

Figure 20 Interface circuits for nEXT turbo pump controllers

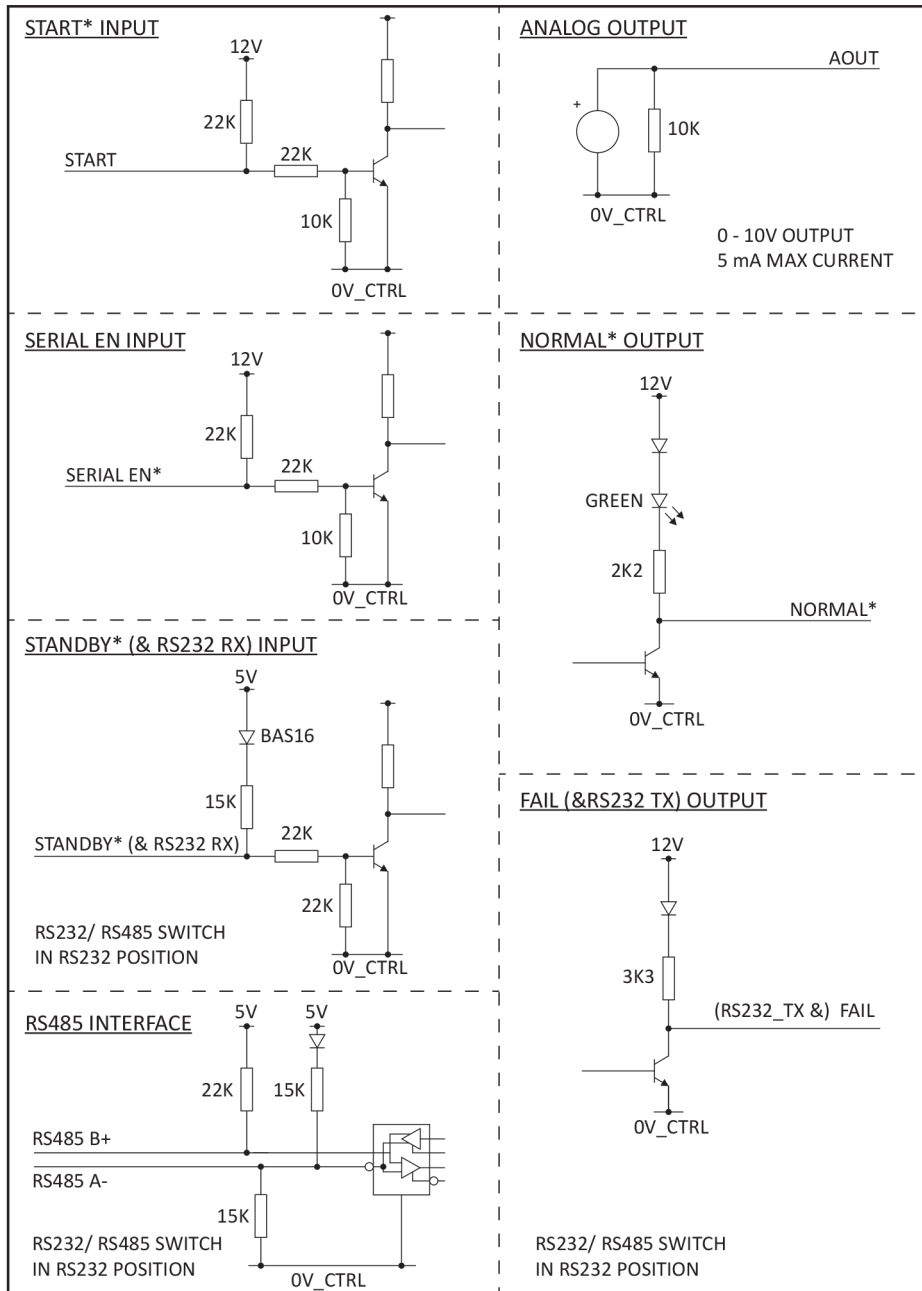

CS/1165/A

Serial protocol

The serial interface link is set to 9600 Baud, 8 bits, 1 stop, no parity with no handshaking. The commands are made up from printable ASCII characters. The maximum message size that can be sent is 80 characters, including start and end characters.

 **Note:**

All alphabetical characters must be sent in upper case format. The response may contain lower case characters.

Every complete command message sent will receive a response - either a status code or a data return. The nEXT85 pump can only process with one message at a time. It will only accept a new message once the response to the previous message has been returned.

If the nEXT85 pump receives characters that are not framed inside start and stop characters, it will ignore them. Messages with the stop character missing will be discarded with no response when a new start character is received. If the nEXT85 pump receives an unrecognisable message between the start and stop characters, it will return an appropriate error message.

Refer to [Multi-drop operation](#) on page 103 for more information about operating the nEXT85 pumps in multi-drop mode.

Command set

Table 50 Summary of commands that can be sent to the pump

Object name	Command	Parameter range	Factory setting	Data type	Units	Comments
Node	!S850	0..99	-	decimal	address	Multi-drop address
	?S850					0 = disable multi-drop address
						99 = wild card
Pump type	?S851	8;	-	string	chars	Pump type
		10;		string	chars	DSP software version number
		4		string	chars	(D39659610) Full speed RPS (1500 for nEXT85)
Pump control	!C852	0	-	decimal	-	Stop the pump
		1				Start the pump
	?V852	0..1800;	-	decimal	RPS	Measured motor speed
		32-bits		hex	flags	System status word
Time setting	!S854	1..30	8	decimal	minutes	Timeout period for both initial ramp
	?S854					up and if speed drops below 50%
Power limit setting	!S855	50..120	80	decimal	Watts	Link power maximum
	?S855					
Normal speed setting	!S856	50..100	80	decimal	%	Normal speed as a percentage of full speed
	?S856					
Standby speed setting	!S857	55..100	70	decimal	%	Standby speed as a percentage of full speed
	?S857					
Temperature readings	?V859	0..100;	-	decimal	°C	Measured motor temperature
		0..100		decimal	°C	Measured motor controller temperature

Object name	Command	Parameter range	Factory setting	Data type	Units	Comments
Link parameter readings	?V860	0..500;	-	decimal	0.1 Volts	Measured link voltage
		0..300;		decimal	0.1 Amps	Measured link current
		0..15000		decimal	0.1 Watts	Measured link power
Pump run hours	?V862	0..65535	-	decimal	hours	Hours run by pump
Temperature readings 2	?V865	-200..200;	-	decimal	°C	Measured motor temperature
		-200..200;		decimal	°C	Measured motor controller temperature
		-200..200		decimal	°C	Measured rotor temperature
Factory settings	!S867	1	-	-	-	Reset all configuration options and parameters to the factory settings
PIC software version	?S868	10	-	string	chars	Boot loader software version number (D396596XXX)
Speed control	!C869	0	-	decimal	-	Set target speed to full speed
		1				Set target speed to standby speed
Timer options	!S870	0	1	decimal	-	Timer = disabled
	?S870	1				Timer = enabled Note that the timer is permanently enabled on ramp-up.
Analogue signal options	!S871	0	0	decimal	-	Analogue output = measured speed
	?S871	1				Analogue output = measured power
		2				Analogue output = measured motor temp.
		3				Analogue output = measured control temp.
		4				Analogue output = measured rotor temp.

Object name	Command	Parameter range	Factory setting	Data type	Units	Comments
Electronic braking options	!S872	0	0	decimal		Electronic braking = disabled
	?S872	1				Electronic braking = enabled Refer to Electronic braking on page 17
Close vent valve	!C875	1	-	decimal	-	Closes the vent valve for delayed start and overrides the current vent option. There is no open vent valve command but the stop command (!C852 0) will clear the override.
Valve 1 type	!S877	0	0	decimal	-	Normally Open Valve
	?S877	1				Normally Closed Valve (power cycle is required)
Valve 2 type	!S878	0	0	decimal	-	Normally Open Valve
	?S878	1				Normally Closed Valve (power cycle is required)
Service status	?V881	32 bits	-	hex	flags	Service status word
Controller run time	?V882	0..999999;	-	decimal	hours	Hours run by controller
		0..999999		decimal	hours	Hours until controller service due
Pump run time	?V883	0..999999;	-	decimal	hours	Hours run by pump
		0..999999		decimal	hours	Hours until pump service due
Pump cycles	?V884	0..65535;	-	decimal	cycles	Cycles run by pump
		0..65535		decimal	cycles	Cycles until pump service due
Bearing run time	?V885	0..999999;	-	decimal	hours	Hours run by bearing
		0..999999		decimal	hours	Hours until bearing service due
Oil cartridge run time	?V886	0..999999;	-	decimal	hours	Hours run by oil cartridge
		0..999999				
		0..999999		decimal	hours	Hours until oil cartridge service due

Table 51 Summary of commands that can be sent to the pump - Vent options 1

Object name	Command	Parameter range	Factory setting	Data type	Units	Comments
Vent options 1	!S853	0	0	decimal		Hard vent when < 50% speed if stop or fail
	?S853	1				Controlled vent if > 50% speed then hard vent if < 50% speed if stop or fail
		2				If stop, hard vent
						If fail, hard vent when < 50% speed
		3				If stop, hard vent
						If fail, controlled vent > 50% speed then hard vent < 50% speed
		4				If fail, hard vent
						If stop, hard vent when < 50% speed
		5				If fail, hard vent
						If stop, controlled vent > 50% speed then hard vent < 50% speed
		6				Hard vent if stop or fail
		7				Same as option 6
		8				Output is permanently energised (Fan ON)
		9				Do not use
		10				Output is permanently de-energised (Fan OFF)
11				Do not use		
12				Do not use		
13				Do not use		
14				Hard vent when < 50% speed if stop		
15				Controlled vent if > 50% speed then hard vent if < 50% speed if stop		

Table 52 Summary of commands that can be sent to the pump - Vent options 2

Object name	Command	Parameter range	Factory setting	Data type	Units	Comments
Vent options 2	!864	0	8	decimal		Hard vent when < 50% speed if stop or fail
	?864	1				Controlled vent if > 50% speed then hard vent if < 50% speed if stop or fail
		2				If stop, hard vent
						If fail, hard vent when < 50% speed
		3				If stop, hard vent
						If fail, controlled vent > 50% speed then hard vent < 50% speed
		4				If fail, hard vent
						If stop, hard vent when < 50% speed
		5				If fail, hard vent
						If stop, controlled vent > 50% speed then hard vent < 50% speed
		6				Hard vent if stop or fail
		7				Same as option 6
		8				Output is permanently energised (Fan ON)
		9				Do not use
		10				Output is permanently de-energised (Fan OFF)
11				Do not use		
12				Do not use		
13				Do not use		
14				Hard vent when < 50% speed if stop		
15				Controlled vent if > 50% speed then hard vent if < 50% speed if stop		

Multi-drop operation

Using multi-drop mode, a single computer system can communicate with more than one nEXT85 pump. Each nEXT85 pump must be assigned its own individual address before it can be

fitted into a multi-drop system. The command to assign the multi-drop address is sent in standard nEXT85 message format (as detailed in [Assigning a multi-drop address](#) on page 43). The message protocol in multi-drop mode is marginally different to that described for serial messages in single pump systems. The main differences in multi-drop message protocol are detailed below:

- All multi-drop commands, queries or replies have the first character #.
- All commands, queries and replies contain a header containing the address of the node that the message is to, followed by the address of the node that the message is from.
- There is a delimiter character: (colon) which separates the two multi-drop addresses in the header.
- The remainder of the message (command, query or reply) follows the same protocol as already described for single pump systems.
- The wild card address 99 is very useful and means 'any' node.

After a nEXT85 pump has been assigned a multi-drop address, it will ignore any messages in the format for single pumps. An individual nEXT85 pump will remain silent and ignore all command messages unless the multi-drop address matches its own address.

Figure 21 Conceptual diagram for multi-drop connection using RS232 interface

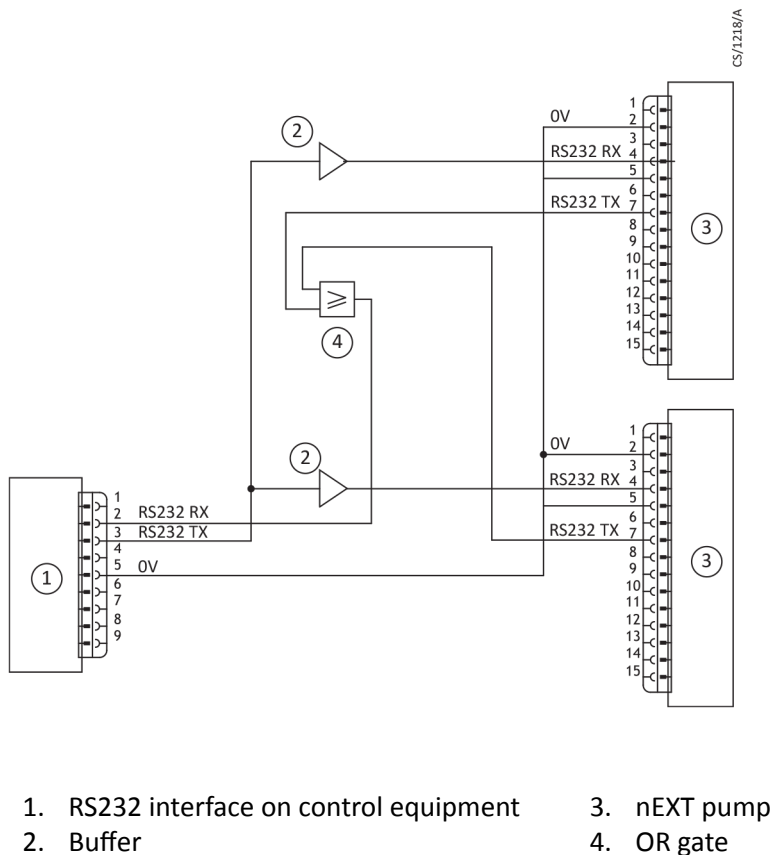

- | | |
|---|--------------|
| 1. RS232 interface on control equipment | 3. nEXT pump |
| 2. Buffer | 4. OR gate |

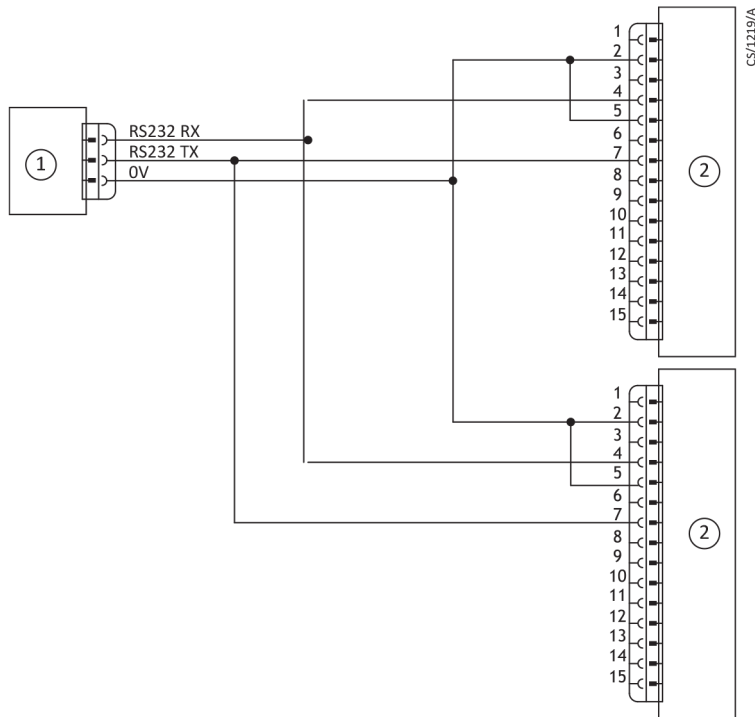
Figure 22 RS485 multi-drop connection

1. RS485 interface on control equipment
2. nEXT pump logic interface

Motor controller auxiliary connector socket

The nEXT85 pump has a 4-way auxiliary connector socket on the side of the motor controller.

The mating plug for this connector is available pre-fitted to a number of accessories or as an accessory on its own (refer to [Accessories for the nEXT85](#) on page 80).

The connector is intended to power a vent valve and/or fan. The connector is shown in [Figure 23](#) on page 106, with the polarity of the pins marked when the vent valve or fan are energised.

The auxiliary connector output is regulated to 24 V d.c. to control the accessories, even when the pump is operating from a 48 V d.c. supply and is protected against overload and short circuits. If the auxiliary load current exceeds the value in [Table 53](#) on page 105, the output will shut down to protect the motor controller.

Table 53 Motor controller technical data

Description	Data
Connector plug	Phoenix part number SACC-DSI-M 8FS-4CON-M12/0.5
Voltage output	24 V d.c. -25%, +10% (18 V d.c. to 26.4 V d.c.)
Current output	500 mA

The motor controller connector provides two independently configured and controlled outputs, Aux output 1 and Aux output 2. This enables any combination of fan or vent valve accessory to be connected, configured and controlled appropriately. Aux output 1 is configured via Vent option 1 and Valve 1 type and Aux output 2 is configured via Vent option 2 and Valve 2 type (refer to [Vent valve control](#) on page 48). Aux output 1 has default settings for a normally open vent valve and Aux output 2 has default settings for a fan.

Edwards nEXT85 air coolers and vent valve accessories (refer to [Accessories for the nEXT85](#) on page 80), which have the corresponding connector fitted, are pre-configured to Aux output 1 and Aux output 2 for convenience and to provide plug and play ability. nEXT85 vent valves are pre-configured to Aux output 1 and the default setting for vent options 1 are appropriate for this type of accessory. nEXT85 air coolers are pre-configured to Aux output 2 and the default setting for vent options 2 are appropriate for this type of accessory.

Bare wire versions of the nEXT85 air coolers and vent valve accessories are available, which are not pre-configured. This enables any combination of accessory to be used and independently configured and controlled on Aux output 1 and Aux output 2.

Figure 23 Motor controller connector showing pin numbers

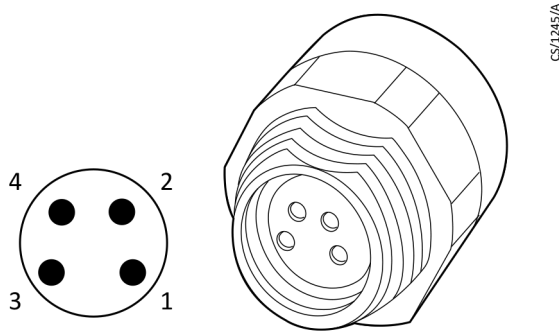

Pin number	Signal	Polarity
1	0V return	Negative
2	Aux output 1	Positive
3	Aux output 2	Positive
4	Chassis	Chassis

Indicator LEDs

The nEXT85 pump has five indicator LEDs. Refer to [Figure 4](#) on page 31.

Table 54 Indicator LEDs

LED	Description
Normal LED	This green LED illuminates when the pump rotational speed is above the normal speed setting, irrespective of whether the pump is accelerating or decelerating. This LED is duplicated on both sides of the pump.
Status LED	This yellow LED flashes with a 50% duty cycle at the rotational frequency of the pump motor. At high speeds it appears continuously illuminated. The LED switches off when the rotational speed is very low or stopped. If a service is due, this LED flashes in a sequence to indicate which service operation is required. Refer to Troubleshooting on page 67. This LED is duplicated on both sides of the pump.

LED	Description
Alarm LED	This red LED flashes in a sequence to indicate an error code if a FAIL condition is preventing pump operation. The error codes can be used for fault finding as described in Troubleshooting on page 67. This LED is duplicated on both sides of the pump.
Serial Communications Receive (Rx) LED	This yellow LED flashes briefly whenever activity is detected on the serial link receive line and can be used for fault finding the serial link.
Serial Communications Transmit (Tx) LED	This yellow LED flashes briefly whenever the motor controller is transmitting data on the serial link transmit line and can be used for fault finding the serial link.

 **Note:**

If an external electrical load is connected to the Normal output line, the normal LED may illuminate.

Definitions

The units used throughout this manual conform to the SI international system of units of measurement. Also throughout this manual, wherever flow rates are specified, the abbreviation 'sccm' is used to mean standard $\text{cm}^3\text{min}^{-1}$: this is a flow of $1 \text{ cm}^3\text{min}^{-1}$ at an ambient temperature of 0°C and a pressure of 1013 mbar ($1.013 \times 10^5 \text{ Pa}$).

Figure 24 HS1 Form

Form HS1

Return of Edwards Equipment - Procedure

INTRODUCTION

Before returning your equipment, you must warn Edwards if substances you used (and produced) in the equipment can be hazardous. This information is fundamental to the safety of our Service Centre employees and will determine the procedures employed to service your equipment.

Complete the Declaration (HS2) and send it to Edwards before you dispatch the equipment. It is important to note that this declaration is for Edwards internal use only, and has no relationship to local, national or international transportation safety or environmental requirements. As the person offering the equipment for shipment, it is your responsibility to ensure compliance with applicable laws.

GUIDELINES

- Equipment is 'uncontaminated' if it has not been used, or if it has only been used with substances that are not hazardous. Your equipment is 'contaminated' if it has been used with any substances classified as hazardous under the UN Globally Harmonised System on the classification and labelling of chemicals (GHS), EU Regulation No 1272/2008 on classification, labelling and packaging (CLP) or US Occupational Safety and Health regulations (29CFR1910.1200, Hazard Communication).
- If your equipment has been used with radioactive substances, biological or infectious agents, mercury, polychlorinated biphenyls (PCB's), dioxins or sodium azide, you must decontaminate it before you return it to Edwards. You must send independent proof of decontamination (for example a certificate of analysis) to Edwards with the Declaration (HS2). Phone Edwards for advice.
- If your equipment is contaminated, you must either:
 - Remove all traces of contamination (to the satisfaction of laws governing the transportation of dangerous/hazardous substances).
 - Or, properly classify the hazard, mark, manifest and ship the equipment in accordance with applicable laws governing the shipment of hazardous materials.

Note: Some contaminated equipment may not be suitable for airfreight.

PROCEDURE

1. Contact Edwards and obtain a Return Authorisation Number* for your equipment.
2. Complete the Return of Edwards Equipment - Declaration (HS2).
3. If the equipment is contaminated, you must contact your transporter to ensure that you properly classify the hazard, mark, manifest and ship the equipment, in accordance with applicable laws governing the shipment of contaminated/hazardous materials. As the person offering the equipment for shipment, it is your responsibility to ensure compliance with applicable law. **Note: Equipment contaminated with some hazardous materials, such as semiconductor by-products, may not be suitable for airfreight - contact your transporter for advice.**
4. Remove all traces of hazardous gases: pass an inert gas through the equipment and any accessories that will be returned to Edwards. Where possible, drain all fluids and lubricants from the equipment and its accessories.
5. Seal up all of the equipment's inlets and outlets (including those where accessories were attached) with blanking flanges or, for uncontaminated product, with heavy gauge tape.
6. Seal equipment in a thick polythene/polyethylene bag or sheet.
7. If the equipment is large, strap the equipment and its accessories to a wooden pallet. If the equipment is too small to be strapped to a pallet, pack it in a suitable strong box.
8. E-mail via scan, fax or post a copy of the original with signature of the Declaration (HS2) to Edwards. The Declaration must arrive before the equipment.
9. Give a copy of the Declaration (HS2) to the transporter. You must tell your transporter if the equipment is contaminated.
10. Seal the original Declaration in a suitable envelope: attach the envelope securely to the outside of the equipment package, in a clear weatherproof bag.
WRITE YOUR RETURN AUTHORISATION NUMBER* CLEARLY ON THE OUTSIDE OF THE ENVELOPE OR ON THE OUTSIDE OF THE EQUIPMENT PACKAGE.

* not applicable in Japan

Figure 25 HS2 Form

Form HS2

Return of Edwards Equipment - Declaration

Return Authorisation Number: _____

- You must:
- Know about **all** of the substances which have been used and produced in the equipment before you complete this Declaration
 - Read the Return of Edwards Equipment - Procedure (HS1) before you complete this Declaration
 - Contact Edwards to obtain a Return Authorisation Number and to obtain advice if you have any questions
 - Send this form to Edwards before you return your equipment as per the procedure in HS1

SECTION 1: EQUIPMENT

Manufacturer's Product Name _____ Manufacturer's Part Number _____ Manufacturer's Serial Number _____ Has the equipment been used, tested or operated? YES, Used or operated <input type="checkbox"/> Go to Section 2 YES, Tested, but not connected to any process or production equipment, and only exposed to Nitrogen, Helium or Air <input type="checkbox"/> Go to Section 4 NO <input type="checkbox"/> Go to Section 4	IF APPLICABLE: Tool Identification Number _____ Tool Manufacturer/OEM _____ Tool Model _____ Process _____ Installed Date _____ De-installed Date _____ Part Number of Replacement Equipment _____ Serial Number of Replacement Equipment _____ Pump datalog attached? YES <input type="checkbox"/> NO <input type="checkbox"/> (Edwards Internal Use Only)
---	---

SECTION 2: SUBSTANCES IN CONTACT WITH THE EQUIPMENT

Are any substances used or produced in the equipment: <ul style="list-style-type: none"> • Radioactive, biological or infectious agents, mercury, poly chlorinated biphenyls (PCBs), dioxins or sodium azide? (if YES, see Note 1) YES <input type="checkbox"/> NO <input type="checkbox"/> • Hazardous to human health and safety? YES <input type="checkbox"/> NO <input type="checkbox"/> 	Note 1: Edwards will not accept delivery of any equipment that is contaminated with radioactive substances, biological/infectious agents, mercury, PCB's, dioxins or sodium azide, unless you: <ul style="list-style-type: none"> • Decontaminate the equipment • Provide proof of decontamination YOU MUST CONTACT EDWARDS FOR ADVICE BEFORE YOU RETURN SUCH EQUIPMENT
--	---

SECTION 3: LIST OF SUBSTANCES IN CONTACT WITH THE EQUIPMENT

Substance name	Chemical Symbol	Precautions required (for example, use protective gloves, etc.)	Action required after a spill, leak or exposure

SECTION 4: RETURN INFORMATION

Reason for return and symptoms of malfunction: _____

For how many hours has the product run? _____ Do you wish to purchase a full Failure Analysis report? YES NO

If you have a warranty claim:

- who did you buy the equipment from? _____
- give the supplier's invoice number _____

SECTION 5: DECLARATION

Print your name: _____ Print your job title: _____

Print your organisation: _____

Print your address: _____

Telephone number: _____ Date of equipment delivery: _____

I have made reasonable enquiry and I have supplied accurate information in this Declaration. I have not withheld any information, and I have followed the Return of Edwards Equipment - Procedure (HS1).

Signed: _____ Date: _____

Note: Please print out this form, sign it and return the signed form as hard copy.

P900-71-000 Issue N