

Instruction Manual

GV Gate Valves

Chemtech Scientific provides access to this content as a courtesy.
We do not own the content contained in this document.
All rights and credit go directly to its rightful owners.

www.chemtechsci.com
Call us at: 484-424-9415



Contents

Section	Page
1	Introduction 1
1.1	Scope and definitions 1
1.2	Description 1
2	Technical data 3
2.1	Performance 3
2.2	Mechanical data 3
2.3	Pneumatically operated GV Valves 10
2.4	Maximum baking temperatures 10
2.5	Construction materials 10
2.6	Item numbers 10
2.6.1	ISO GV Valves 10
2.6.2	ANSI GV Valves 11
2.6.3	CF GV Valves 11
3	Installation 13
3.1	Unpack and inspect 13
3.2	Installation requirements 13
3.3	Fit the GV Valve 14
3.4	Pneumatic connections (pneumatic GV Valves only) 14
3.5	Position indicator connections (pneumatic valves only) 17
3.5.1	Valves with microswitches 17
3.5.2	GV Valves with reed switches 17
4	Operation 19
4.1	Manual GV Valves 19
4.2	Pneumatic GV Valves 19
5	Maintenance 21
6	Storage and disposal 23
6.1	Storage 23
6.2	Disposal 23
7	Service, spares and accessories 25
7.1	Introduction 25
7.2	Service 25
7.3	Spares 25
7.4	Accessories 28

For return of equipment, complete the HS Forms at the end of this manual.

Illustrations

Figure		Page
1	Dimensions of manual GV Valves (see Table 2)	4
2	Dimensions of pneumatic GV Valves with microswitches (see Table 2)	5
3	Dimensions of pneumatic GV Valves with reed switches (see Table 2)	8
4	Flange dimensions (see Table 3)	9
5	Typical pneumatic circuit	16
6	Wiring diagram for pneumatic GV Valves with reed switches	20

Tables

Table		Page
1	Technical data	3
2	GV Valve body and flange dimensions (mm)	6
3	GV Valve body and flange dimensions (mm)	6
4	Spares for GV Valves manufactured in 1996 and later	25
5	Spares for GV Valves manufactured in 1993 to 1995	27

Trademark credits

ConFlat® is a trademark of the Varian Corporation

1 Introduction

1.1 Scope and definitions

This manual provides installation, operation and maintenance instructions for the Edwards GV Gate Valves (referred to as GV Valves throughout the remainder of this manual). The GV valves must be used as specified in this manual. Read this manual before installing and operating the GV valve.

Important safety information is highlighted as WARNING and CAUTION instructions; these instructions must be obeyed. The use of WARNINGS and CAUTIONS is defined below.



WARNING

Warnings are given where failure to observe the instruction could result in injury or death to people.

CAUTION

Cautions are given where failure to observe the instruction could result in damage to the equipment, associated equipment and process.

The units used throughout this manual conform to the SI international system of units of measurement.

1.2 Description

The GV Valves are bellows-sealed gate valves for use in applications which require high leak tightness and a minimum of hydrocarbons in the vacuum system.

The GV Valves have stainless steel bodies of vacuum-brazed construction. The valve bodies have been electropolished both inside and out and have been baked to 1100 °C during manufacture. This eliminates the possibility of virtual leaks in the GV Valve and ensures that the GV Valve has low outgassing characteristics.

GV Valves are available with ISO flanges, ANSI flanges and CF (ConFlat®) metal sealed flanges. Use CF flanged GV Valves for applications which require ultra-high vacuum and very high baking temperatures. ISO and ANSI valves are supplied with fluoroelastomer bonnet seals. CF GV Valves have metal bonnet seals. All GV Valves have fluoroelastomer valve plate seals.

Manual and pneumatically actuated GV Valves are available. The pneumatically actuated GV Valves have position indicators that can be used by the customer control equipment to determine when the valve is open or closed.

- GVI*P pneumatically actuated ISO valves have reed switch position indicators (see [Section 3.5.2](#)).
- Other pneumatically actuated ISO GV Valves and all pneumatically actuated CF GV Valves have microswitch position indicators (see [Section 3.5.1](#)).

2 Technical data

2.1 Performance

Operating pressure range	< 1 x 10 ⁻⁹ mbar to 1 bar (absolute) (1 x 10 ⁻⁷ to 1 x 10 ⁵ Pa)
Leak tightness	< 1 x 10 ⁻⁹ mbar l s ⁻¹ (1 x 10 ⁻⁷ Pa l s ⁻¹)
Maximum pressure differential across the valve plate (opening)	30 mbar (3 x 10 ³ Pa)
Molecular conductance	See Table 1
Average life before first service	100,000 open/close cycles (dependent on the application)

2.2 Mechanical data

Dimensions	See Figure 1 to 3 and Table 2
Flange sizes	See Table 2
Mass	See Table 1
Mounting position	Any orientation

Table 1 - Technical data

GV Valve	Molecular conductance (l s ⁻¹)	Approximate mass (kg)	Manual GV Valves	Pneumatic GV Valves	
			No of turns of handle to open/ close the valve	Pneumatic cylinder capacity (l)	Minimum closing and opening time (s) at 80 psi (5.5 x 10 ⁵ Pa)
GVI040, GVC015	130	5	5	0.033	1.5
GVI050, GVA/GVC020	250	6	5	0.033	1.5
GVI063, GVI063P, GVA/GVC025	520	8	6	0.112	1.5
GVI100, GVI100P, GVA/GVC040	2000	15	10	0.233	2.5
GVI160, GVI160P, GVA/GVC060	6300	23	10	0.233	2.5
GVI200, GVA/GVC080	15000	34	10	0.416	2.5
GVI250, GVA/GVC100	23000	73	14	0.520	4.5
GVI320, GVA/GVC120	39000	77	15	0.520	4.5

Figure 1 - Dimensions of manual GV Valves (see Table 2)

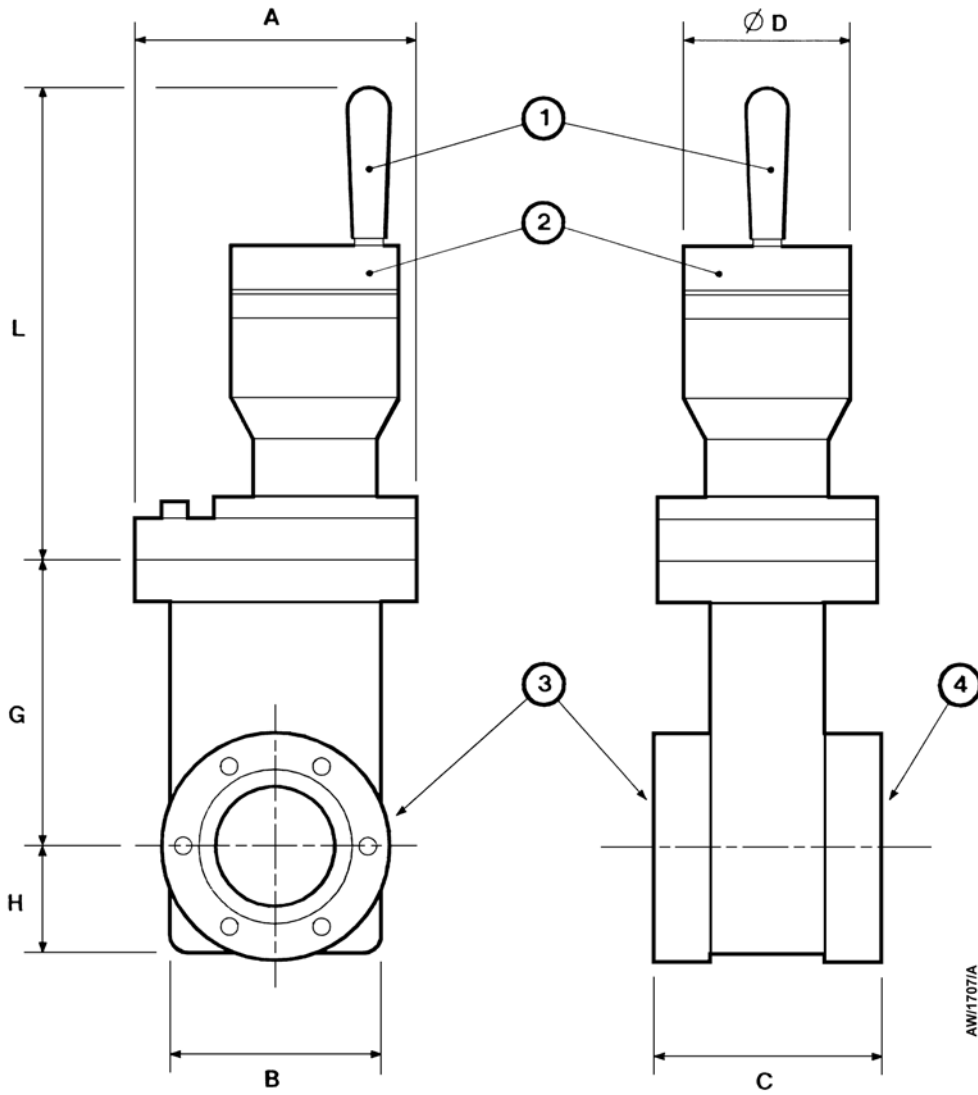

AW1707/A

1. Grasp type valve handle: GV Valves with flanges 100 mm (4 inches) and larger
2. Knurled valve handle: GV Valves with flanges up to 75 mm (3 inches)
3. Carriage side
4. Seal side

Figure 2 - Dimensions of pneumatic GV Valves with microswitches (see Table 2)

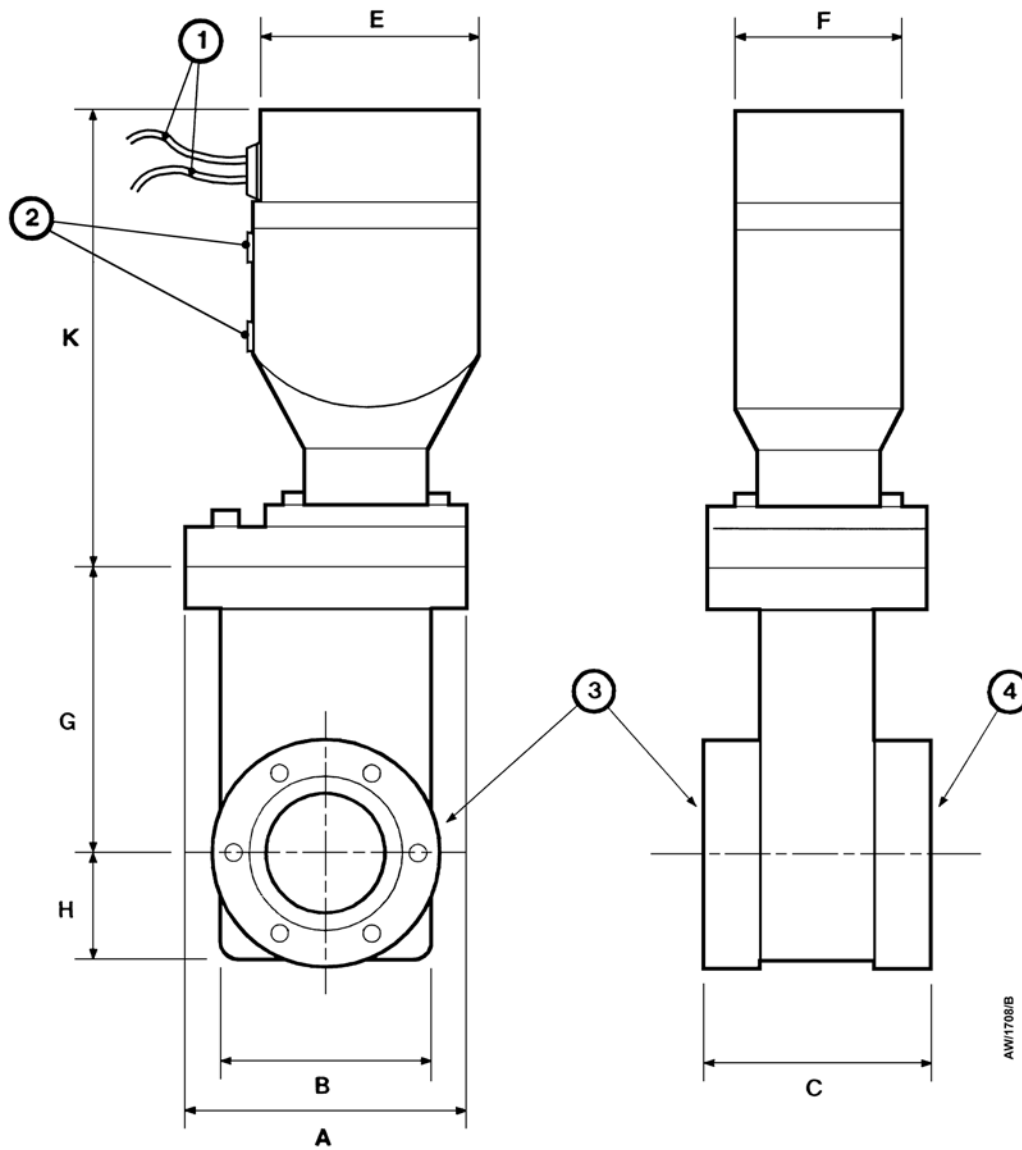

1. Position indicator wires
2. 1/8 inch NPT ports
3. Carriage side
4. Seal side

Table 2 - GV Valve body and flange dimensions (mm)

Valve	Nominal bore size	A	B	C	D	E	F	G	H	K
GVI040	40 mm	84.1	26.2	51.6	50.8	69.3	50.7	86.1	33.0	134.9
GVI050	50 mm	96.8	75.2	57.9	50.8	69.3	50.7	104.5	37.6	134.9
GVI063/P	63 mm	111.0	89.4	51.6	50.8	69.3	50.7	122.1	43.1	134.9
GVI100/P	100 mm	177.8	143.5	61.2	75.5	93.5	76.2	206.4	66.9	175.6
GVI160/P	160 mm	222.3	191.8	67.0	75.5	93.5	76.2	270.5	87.6	175.6
GVI200	200 mm	285.8	254.5	67.6	75.5	93.5	76.2	353.4	114.6	175.6
GVI250	250 mm	341.1	303.5	80.0	88.9	120.4	120.4	460.6	146.6	240.7
GVI320	320 mm	408.2	362.7	80.0	88.9	120.4	120.4	560.5	174.9	240.7
GVA020	2 inches	96.8	75.2	51.6	50.8	69.3	50.7	104.5	37.6	134.9
GVA025	2.5 inches	111.0	89.4	51.6	50.8	69.3	50.7	122.1	43.1	134.9
GVA040	4 inches	177.8	143.5	61.2	75.9	93.5	76.2	206.4	66.9	175.6
GVA060	6 inches	222.3	191.8	61.2	75.9	93.5	76.2	270.5	87.6	175.6
GVA080	8 inches	285.8	254.5	70.3	75.9	93.5	76.2	353.4	114.6	175.6
GVA100	10 inches	341.4	303.5	80.0	88.9	120.4	101.6	460.6	146.6	240.7
GVA120	12 inches	403.2	362.7	80.0	88.9	120.4	101.6	560.5	174.9	240.7
GVC015	1.5 inches	84.1	62.5	51.6	50.8	69.3	50.7	86.1	33.0	134.9
GVC020	2 inches	96.8	75.2	57.9	50.8	69.3	50.7	104.5	37.6	134.9
GVC025	2.5 inches	111.0	89.4	61.2	50.8	69.3	50.7	122.1	43.1	134.9
GVC040	4 inches	177.8	143.5	75.4	75.9	93.5	76.2	206.4	66.9	175.6
GVC060	6 inches	222.3	191.8	80.5	75.9	93.5	76.2	270.5	87.6	175.6
GVC080	8 inches	285.8	254.5	85.1	75.9	93.5	76.2	353.4	114.6	175.6
GVC100	10 inches	341.4	303.5	98.8	88.9	120.4	101.6	460.6	146.6	240.7
GVC120	12 inches	403.2	362.7	98.8	88.9	120.4	101.6	560.5	174.9	240.7

Table 3 - GV Valve body and flange dimensions (mm)

Valve	L	M	N	P	S	T	V
GVI040	91.7	69.9	38.1	-	41.2	-	12.7
GVI050	91.7	74.9	50.8	-	52.2	-	12.7
GVI063/P	91.7	130.1	63.5	4	110.0	M8	12.7
GVI100/P	201.3	165.1	101.6	8	145.0	M8	12.7
GVI160/P	201.3	225.0	152.4	8	200.0	M10	12.1
GVI200	201.3	258.8	203.2	12	260.0	M10	15.9
GVI250	231.7	335.0	254.0	12	310.0	M10	19.0
GVI320	231.7	425.0	304.8	12	395.0	M12	19.0
GVA020	91.7	151.6	50.8	4	120.7	3/8-16	12.7
GVA025	91.7	151.6	63.5	4	120.7	3/8-16	12.7
GVA040	190.6	228.4	101.9	8	192.8	3/8-16	12.7
GVA060	200.2	279.4	152.4	8	241.3	3/4-10	12.7
GVA080	200.2	279.4	203.3	8	241.3	3/4-10	17.2
GVA100	231.7	406.4	254.0	12	362.0	3/4-10	19.1

Table 3 - GV Valve body and flange dimensions (mm) (continued)

Valve	L	M	N	P	S	T	V
GVA120	231.7	406.4	304.8	12	362.0	3/4-10	19.1
GVC015	91.7	69.3	38.1	6	58.7	M6	12.7
GVC020	91.7	85.7	50.8	8	72.4	M8	15.9
GVC025	91.7	113.5	63.5	8	92.2	M8	17.5
GVC040	190.6	151.6	101.9	16	130.3	M8	19.8
GVC060	200.2	202.4	152.4	20	181.1	M8	22.4
GVC080	200.2	253.2	203.2	24	231.9	M8	24.6
GVC100	231.7	304.8	254.0	32	284.0	M8	28.5
GVC120	231.7	354.6	304.8	30	325.4	M10	28.5

Figure 3 - Dimensions of pneumatic GV Valves with reed switches (see Table 2)

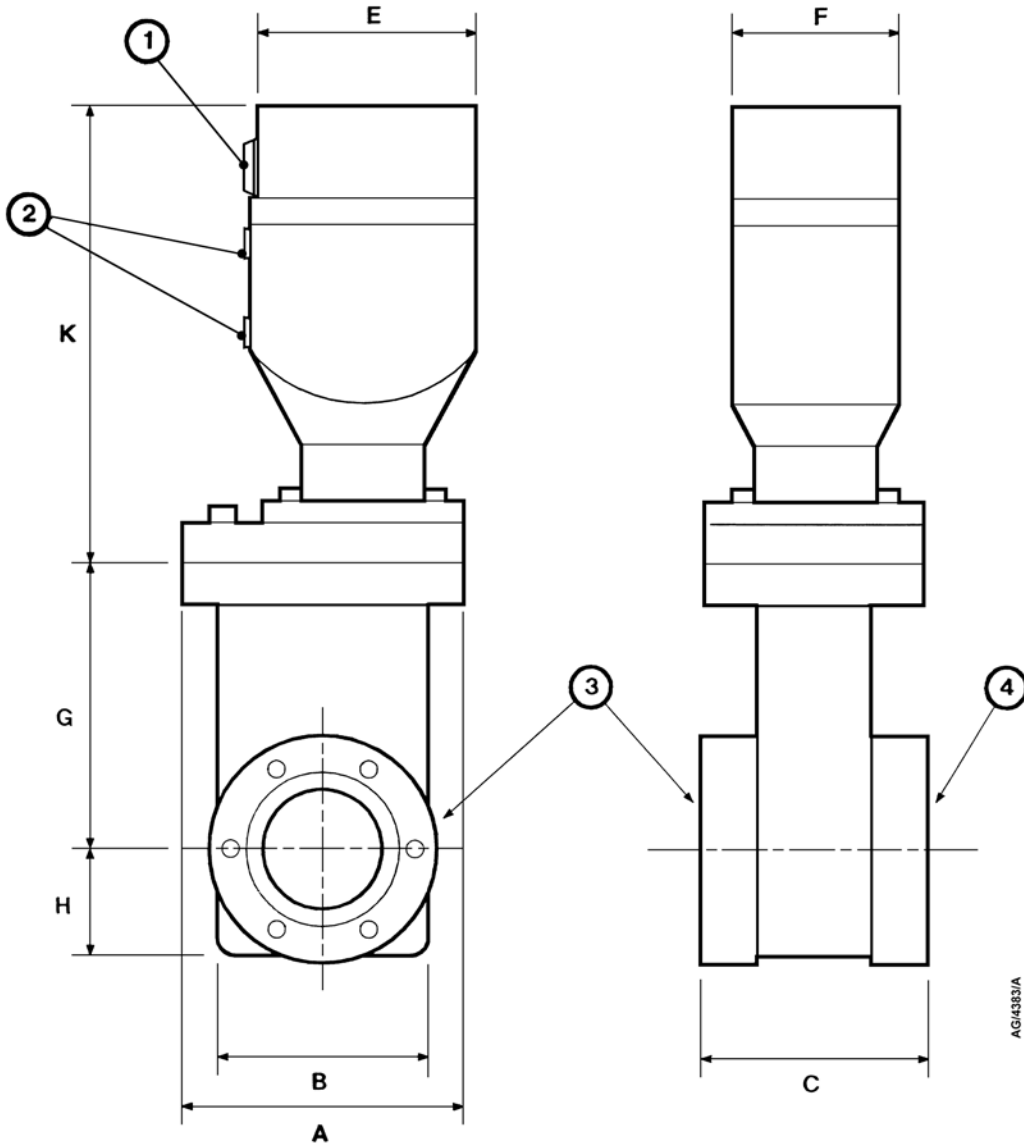

- 1. Electrical connector (refer to Section 3.5.2)
- 2. 1/8-inch NPT ports
- 3. Carriage side
- 4. Seal side

Figure 4 - Flange dimensions (see Table 3)

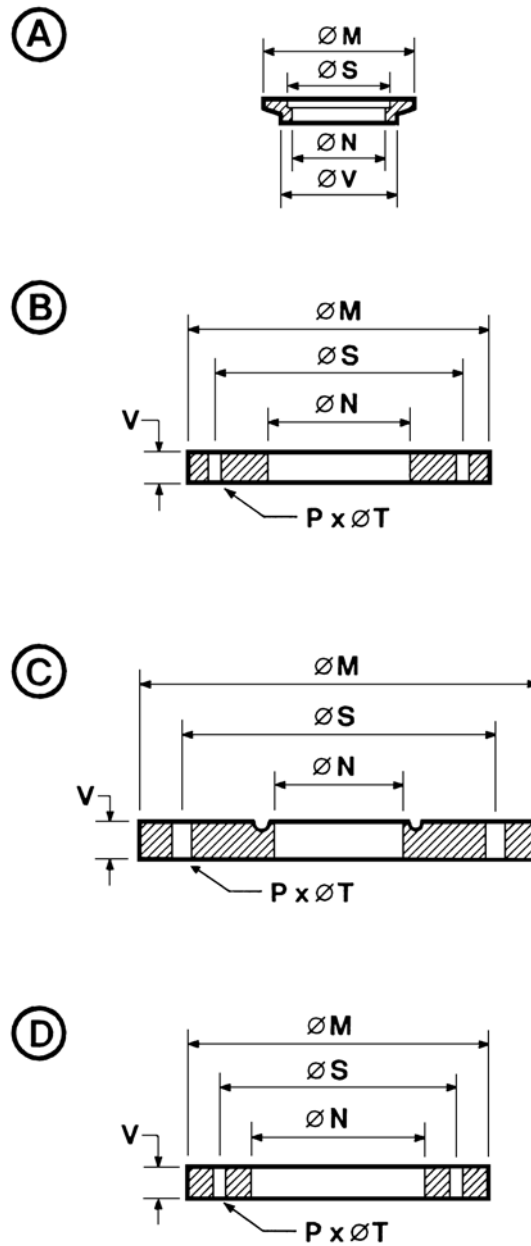

AW1709/A

- A. NW flange
- B. ISO flange
- C. ANSI flange
- D. CF flange

P = number of holes of diameter T

2.3 Pneumatically operated GV Valves

The pneumatic supply should be dry and filtered. Lubricated or non-lubricated air may be used.

Pneumatic supply pressure	80 psig (5.5 bar gauge, 6.5 bar absolute, 6.5×10^5 Pa)
Pneumatic connections	1/8 inch NPT
Position indicator switch contact rating	28 V, 20 mA a.c. and d.c.

2.4 Maximum baking temperatures

Valve body	
Fluoroelastomer sealed bonnet	150 °C
Metal sealed bonnet	
Valve open	250 °C
Valve closed	150 °C
Manual actuator	100 °C
Pneumatic actuator	100 °C

2.5 Construction materials

The GV Valves are manufactured from the following materials:

Valve body	AISI 304 stainless steel
Valve plate	AISI 304 stainless steel
Mechanism	AISI 304 stainless steel
Bearings	Hardened high carbon chrome steel
Circlips	SS PH 15-7 Mo
Bellows	AM 350
Seals, valve plate	Fluoroelastomer

2.6 Item numbers

2.6.1 ISO GV Valves

Valve	Flange	Item Number	
		Manual valve	Pneumatic valve
GVI040	NW40	B650-01-000	B650-51-000
GVI050	NW50	B651-01-000	B651-51-000
GVI063	ISO63	B652-01-000	B652-51-000
GVI100	ISO100	B653-01-000	B653-51-000
GVI160	ISO160	B654-01-000	B654-51-000
GVI200	ISO200	B655-01-000	B655-51-000
GVI250	ISO250	B656-01-000	B656-51-000
GVI320	ISO320	B657-01-000	B657-51-000

Valve	Flange	Item Number	
		Manual valve	Pneumatic valve
GVI063P	ISO63	-	B652-54-000
GVI100P	ISO100	-	B653-54-000
GVI160P	ISO160	-	B654-54-000

2.6.2 ANSI GV Valves

Valve	Flange	Item Number	
		Manual valve	Pneumatic valve
GVA020	ANSI2	B651-02-000	B651-52-000
GVA025	ANSI2	B652-02-000	B652-52-000
GVA040	ANSI4	B653-02-000	B653-52-000
GVA060	ANSI6	B654-02-000	B654-52-000
GVA080	ANSI6	B655-02-000	B655-52-000
GVA100	ANSI10	B656-02-000	B656-52-000
GVA120	ANSI10	B657-02-000	B657-52-000

2.6.3 CF GV Valves

Valve	Flange	Item Number	
		Manual valve	Pneumatic valve
GVC015	2.73 inch o.d. CF	B650-03-000	B650-53-000
GVC020	3.37 inch o.d. CF	B651-03-000	B651-53-000
GVC025	4.47 inch o.d. CF	B652-03-000	B652-53-000
GVC040	6.00 inch o.d. CF	B653-03-000	B653-53-000
GVC063	8.00 inch o.d. CF	B654-03-000	B654-53-000
GVC080	10.00 inch o.d. CF	B655-03-000	B655-53-000
GVC100	12.00 inch o.d. CF	B656-03-000	B656-53-000
GVC120	14.00 inch o.d. CF	B657-03-000	B657-53-000

3 Installation



WARNING

Where necessary, use suitable lifting equipment to move the valve. Refer to [Table 1](#) for the mass of the valves.

3.1 Unpack and inspect

Remove all the packing materials and check the GV Valve; do not remove the protective covers from the valve flanges yet.

If the GV Valve is damaged, notify the supplier and the carrier in writing within three days; state the Item Number of the GV Valve together with the order number and the supplier's invoice number. Retain the packing materials for inspection. Do not use the GV Valve if it is damaged.

If the GV Valve is not to be used immediately, store the GV Valve in suitable conditions as described in [Section 6](#).

3.2 Installation requirements



WARNING

Take appropriate precautions when installing the GV Valve in a system in which dangerous process substances have been pumped.

The GV Valve can be fitted in any orientation. However, Edwards recommends installing the GV Valve with the carriage side of the valve plate on the high-vacuum side of the vacuum system. This ensures that the valve body is under vacuum at all times and prevents the need to pump down the valve body.

The GV Valve is supported by the pipeline it is fitted to. Ensure that:

- The GV Valve and the adjacent pipelines are adequately supported.
- The pipeline flanges are in line, parallel and the correct distance apart, to prevent stress on the valve body.
- The installation design and configuration is suitable for the GV Valve. If it is not, the GV Valve may leak.
- Flexible bellows are installed in the pipeline to prevent the transmission of stress to the valve body during baking or from the mass of the other components in the vacuum system.

For CF GV Valves, use copper gaskets to seal the valve.

For ISO and ANSI GV Valves, Edwards recommends using trapped O-rings to seal a GV Valve with a flange size greater than 50 mm (2 inches), unless the GV Valve is used in an application where there must be no trapped volumes. In these applications, Co-Seals can be used as long as:

- The valve body and the pipelines are supported so that there is even loading of the Co-Seal faces.
- The securing bolts are evenly tightened to a maximum torque of 5 Nm.

When installing a manual GV Valve, ensure that there is access to the valve handle.

3.3 Fit the GV Valve



WARNING

Install the GV Valve so that fingers or other parts of the body cannot get trapped by exposed parts of the valve mechanism.

Install the GV Valve in clean conditions and wear clean, lint-free gloves to touch the GV Valve. If not, the GV Valve may be contaminated and may outgas when it is installed.

Use suitable clamps to fit GVI040 and GVI050 Valves, which have NW flanges.

All other GV Valves have two flanges, each of which has tapped holes. Use bolts of the correct length to fit the GV Valve. Edwards recommends using bolts that are at least 6 mm (1/4 inch) shorter than the thickness of both mating flanges and seal. If longer bolts are used, the body panels and the sealing surface of the gate O-ring and the GV Valve may be damaged and may leak. Use the following procedure:

1. Remove the flange covers from the GV Valve and wipe the flanges and the gaskets with a clean, dry, lint-free cloth.
2. If the pipeline has O-ring seal flanges, apply a light wipe of high vacuum grease (such as Fomblin RT15) to the O-ring, then fit the O-ring in the groove in the flange.
3. Place the GV Valve between the pipeline flanges and in the required orientation (refer to [Section 3.2](#)).
4. If the GV Valve will be baked, lightly grease the securing bolts with a suitable high temperature, anti-seize compound.
5. Fit the securing bolts, then tighten them progressively and alternately (that is, tighten one bolt by a few turns, then tighten the bolt on the opposite side of the valve, then tighten the bolt adjacent to the first bolt, and so on) to the following maximum torques:
 - Co-Seals: 5 Nm
 - O-ring seals: 7 to 14 Nm
 - CF flanges up to 63 mm (2 1/2 inch) outside diameter: 22 Nm.

If the bolts are not tightened correctly, the GV Valve may leak.

3.4 Pneumatic connections (pneumatic GV Valves only)



WARNING

Control the release of compressed air when connecting or disconnecting the pneumatic supply to unscrew and remove the check valve. If not, the sudden release of high-pressure air may cause injury.

The GV Valve is supplied with the pneumatic cylinder pressurised to secure the valve plate during transit.

- GV Valves with nominal flange size less than 200 mm (8 inches) are supplied with the GV Valve secured in the open position; a check valve is fitted to the pneumatic connection closest to the valve body to maintain the pressure in the pneumatic cylinder.
- GV Valves with nominal flange size greater than or equal to 200 mm (8 inches) are supplied with the GV Valve secured in the closed position; a check valve is fitted to the pneumatic connection furthest from the valve body to maintain the pressure in the pneumatic cylinder.

1. Slowly unscrew the check valve to release the pressure in the pneumatic cylinder. Do not fully unscrew the check valve.
2. When the pneumatic cylinder is at atmospheric pressure, remove the check valve.
3. Use suitable components (refer to [Section 2](#)) to connect the pneumatic supply to the two pneumatic connections on the double-acting actuating cylinder on the GV Valve. Ensure that the connections comply with all local pneumatic regulations, and that the pneumatic supply complies with the requirements of [Section 2.3](#). If it does not, the GV Valve can be damaged. A typical pneumatic circuit is shown in [Figure 5](#).
4. Edwards recommends fitting an electropneumatic control valve accessory (refer to [Section 7](#)), to allow the adjustment of opening and closing times of the GV Valve. Fit the electropneumatic control valve as described in the instruction manual supplied with the control valve. If a control valve is fitted, the check valve (removed in [Step 1 and 2](#)) can be fitted to the inlet of the control valve, to maintain the GV Valve position if the pneumatic supply fails (see [Figure 5](#)).
5. When the pneumatic supply is connected to the GV Valve, set the opening and closing times to those shown in [Table 1](#). If not, when the GV Valve is operated, it may be damaged and may leak. Refer to the instruction manual supplied with the electropneumatic control valve to adjust the opening and closing times.

Figure 5 - Typical pneumatic circuit

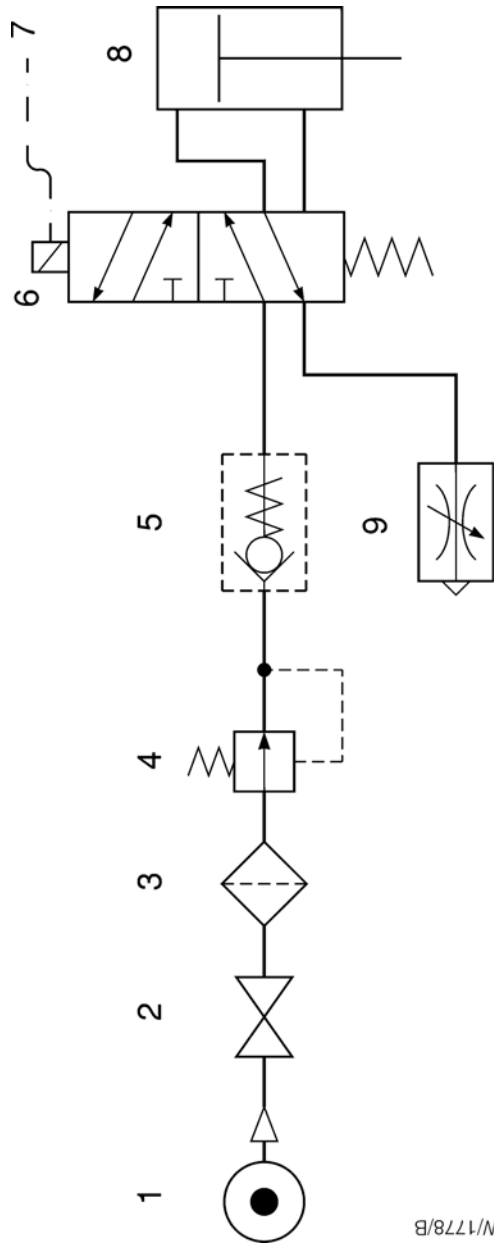

- 1. Compressed air supply
- 2. Shut-off valve
- 3. Filter
- 4. Pressure regulator
- 5. Check valve (optional)
- 6. Control valve
- 7. Electrical connections
- 8. GV Valve
- 9. Flow controller

3.5 Position indicator connections (pneumatic valves only)

Note: GVI**P pneumatic GV Valves have reed switches (see [Section 3.5.2](#)); all other pneumatic GV Valves have microswitches (see [Section 3.5.1](#)).

3.5.1 Valves with microswitches

The pneumatic GV Valve has two microswitches: a fully open microswitch which operates when the GV Valve is fully open, and a fully closed microswitch which operates when the GV Valve is fully closed. Two black wires are connected to the outputs of the fully open microswitch and two white wires are connected to the outputs of the fully closed microswitch. Connect these wires ([Figure 2](#), item 1) to the control equipment. The signals on the wires are used as follows:

- The signal on the white wires is normally open and closes when the GV Valve is fully closed.
- The signal on the black wires is normally open and closes when the GV Valve is fully open.

3.5.2 GV Valves with reed switches

The pneumatic GV Valve has two reed switches: a fully open reed switch which operates when the GV Valve is fully open, and a fully closed reed switch which operates when the GV Valve is fully closed. A red and a black wire are connected to each of these switches and to the electrical connector on the GV Valve ([Figure 3](#), item 1). Use the connector mating half supplied to connect the outputs of the reed switches to the control equipment: refer to the wiring diagram shown in [Figure 6](#).

4 Operation

4.1 Manual GV Valves

Note: There are two types of valve handle: a grasp type handle (Figure 1, item 1) fitted to 100 mm (4 inch) and larger GV Valves, and a knurled handle (Figure 1, item 2) fitted to 75 mm (3 inch) and smaller GV Valves.

To open the GV Valve, turn the valve handle anticlockwise until it cannot be turned any more.

To close the GV Valve, turn the valve handle clockwise until the GV Valve is heard to lock 'over centre' in the fully closed position. If a leak across the valve plate seal is suspected, do not over-tighten the valve handle to stop the leak. When the gate mechanism has gone 'over centre' to seal the GV Valve, any further tightening will increase the leak rate across the plate seal and will damage the valve mechanism.

4.2 Pneumatic GV Valves

To close the GV Valve, slowly increase the pneumatic supply pressure to the valve from 0 psig (1 bar absolute, 1×10^5 Pa) until the GV Valve is heard to lock 'over centre' in the fully closed position.

To open the GV Valve, slowly decrease the pneumatic supply pressure to the GV Valve to 0 psig (1 bar absolute, 1×10^5 Pa).

If a check valve is not fitted as described in Step 4 of Section 3.4, when the pneumatic supply fails or is vented to atmosphere:

- A closed GV Valve will remain fully closed
- An open GV Valve will start to close but will not lock 'over centre' and fully close.

The outputs of the GV Valve position indicator microswitches can be used at all times to identify if the GV Valve is fully open, fully closed or partly open (see Section 3.5).

Figure 6 - Wiring diagram for pneumatic GV Valves with reed switches

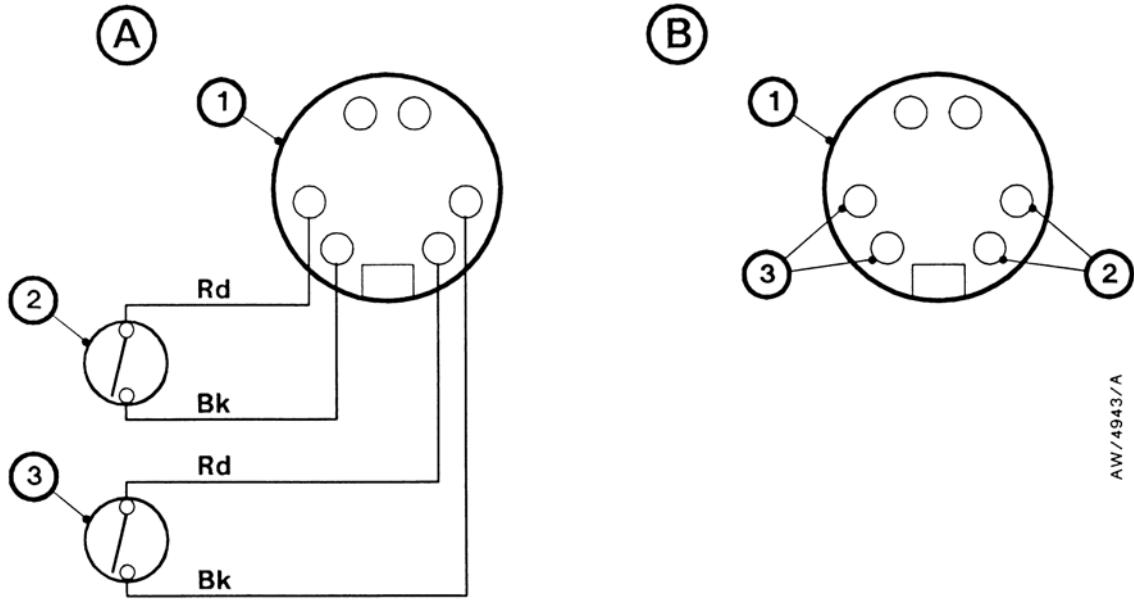

A. Connector viewed from wiring end Rd Red
B. Connector viewed from exterior Bk Black

- 1. Electrical connector
- 2. Valve open switch
- 3. Valve closed switch

5 Maintenance

Check the following items as appropriate when maintaining the vacuum system:

- Inspect the GV Valve vacuum connections and check that they are tight. Tighten any loose connections.
- Inspect all pneumatic connections and check that they are tight. Tighten any loose connections.
- Inspect all pneumatic pipes and check that they are not damaged. Replace any damaged pipes.
- Inspect the valve position indicator electrical connections and check that they are tight. Tighten any loose connections.
- Check that the valve plate opens and closes smoothly when the valve is operated.
- Check that the valve plate and other seals are leak tight.

6 Storage and disposal

6.1 Storage

Place protective covers over the valve flanges (and pneumatic ports, if applicable) and store the GV Valve in cool, dry conditions until required for use.

When required, prepare and install the GV Valve as described in [Section 3](#).

6.2 Disposal

Dispose of the GV Valve and any components removed from it safely in accordance with all local and national safety and environmental requirements.

7 Service, spares and accessories

7.1 Introduction

Edwards products, spares and accessories are available from Edwards companies in Belgium, Brazil, China, France, Germany, Israel, Italy, Japan, Korea, Singapore, United Kingdom, U.S.A. and a world-wide network of distributors. The majority of these centres employ Service Engineers who have undergone comprehensive Edwards training courses.

Order spare parts and accessories from the nearest Edwards company or distributor. When ordering, state for each part required:

- Model and Item Number of the equipment
- Serial number
- Item Number and description of the part

7.2 Service

Edwards products are supported by a world-wide network of Edwards Service Centres. Each Service Centre offers a wide range of options including: equipment decontamination; service exchange; repair; rebuild and testing to factory specifications. Equipment which has been serviced, repaired or rebuilt is returned with a full warranty.

Local Service Centres can also provide Edwards engineers to support on-site maintenance, service or repair of equipment.

For more information about service options, contact the nearest Service Centre or other Edwards company.

7.3 Spares

Refer to [Table 4](#) and [5](#) for the spares kits available for the GV Valves:

- Seals Kits contain gate O-ring, bonnet seal and pneumatic actuator O-rings.
- Bellows Kits contain bonnet/bellows/actuator link welded assembly, and circlip (as required).
- Pins and Bearings Kits contain pins, washers, bearings, springs and wheels (as required).

Table 4 - Spares for GV Valves manufactured in 1996 and later

Flange size	Nominal bore: mm (inches)	Valve model	Seals Kits	Bellows Kits	Pins and bearings Kits
NW40	40 (1 1/2)	GVI040	B650-01-020	B650-01-030	B650-01-040
NW50	50 (2)	GVI050	B651-01-020	B650-01-030	B651-01-040
ISO63	63 (2 1/2)	GVI063	B652-01-020	B650-01-030	B652-01-040
ISO100	100 (4)	GVI100	B653-01-020	B653-01-030	B653-01-040
ISO160	160 (6)	GVI160	B654-01-020	B653-01-030	B654-01-040
ISO200	200 (8)	GVI200	B655-01-020	B653-01-030	B655-01-040
ISO250	250 (10)	GVI250	B656-01-020	B656-01-030	B656-01-040
ISO320	320 (12)	GVI320	B657-01-020	B656-01-030	B657-01-040
NW40	40 (1 1/2)	GVI040P	B650-01-020	B650-01-030	B650-01-040
NW50	50 (2)	GVI050P	B651-01-020	B650-01-030	B651-01-040

Table 4 - Spares for GV Valves manufactured in 1996 and later (continued)

Flange size	Nominal bore: mm (inches)	Valve model	Seals Kits	Bellows Kits	Pins and bearings Kits
ISO63	63 (2 1/2)	GVI063P	B652-01-020	B650-01-030	B652-01-040
ISO100	100 (4)	GVI100P	B653-01-020	B653-01-030	B653-01-040
ISO160	160 (6)	GVI160P	B654-01-020	B653-01-030	B654-01-040
ISO200	200 (8)	GVI200P	B655-01-020	B653-01-030	B655-01-040
ISO250	250 (10)	GVI250P	B656-01-020	B656-01-030	B656-01-040
ISO320	320 (12)	GVI320P	B657-01-020	B656-01-030	B657-01-040
2 inch ANSI	50 (2)	GVA020	B651-01-020	B650-01-030	B651-01-040
2 inch ANSI	63 (2 1/2)	GVA025	B652-01-020	B650-01-030	B652-01-040
4 inch ANSI	100 (4)	GVA040	B653-01-020	B653-01-030	B653-01-040
6 inch ANSI	160 (6)	GVA060	B654-01-020	B653-01-030	B654-01-040
6 inch ANSI	200 (8)	GVA080	B655-01-020	B653-01-030	B655-01-040
10 inch ANSI	250 (10)	GVA100	B656-01-020	B656-01-030	B656-01-040
10 inch ANSI	320 (12)	GVA120	B657-01-020	B656-01-030	B657-01-040
2 inch ANSI	50 (2)	GVA020P	B651-01-020	B650-01-030	B651-01-040
2 inch ANSI	63 (2 1/2)	GVA025P	B652-01-020	B650-01-030	B652-01-040
4 inch ANSI	100 (4)	GVA040P	B653-01-020	B653-01-030	B653-01-040
6 inch ANSI	160 (6)	GVA060P	B654-01-020	B653-01-030	B654-01-040
6 inch ANSI	200 (8)	GVA080P	B655-01-020	B653-01-030	B655-01-040
10 inch ANSI	250 (10)	GVA100P	B656-01-020	B656-01-030	B656-01-040
10 inch ANSI	320 (12)	GVA120P	B657-01-020	B656-01-030	B657-01-040
2.37 inch o.d. CF	40 (1 1/2)	GVC015	B650-03-020	B650-03-030	B650-01-040
3.37 inch o.d. CF	50 (2)	GVC020	B651-03-020	B651-03-030	B651-01-040
4.47 inch o.d. CF	63 (2 1/2)	GVC025	B652-03-020	B652-03-030	B652-01-040
6.00 inch o.d. CF	100 (4)	GVC040	B653-03-020	B653-03-030	B653-03-040
8.00 inch o.d. CF	160 (6)	GVC060	B654-03-020	B654-03-030	B654-03-040
10.00 inch o.d. CF	200 (8)	GVC080	B655-03-020	B655-03-030	B655-03-040
12.00 inch o.d. CF	250 (10)	GVC100	B656-03-020	B656-03-030	B656-03-040
14.00 inch o.d. CF	320 (12)	GVC120	B657-03-020	B657-03-030	B657-03-040
2.37 inch o.d. CF	40 (1 1/2)	GVC015P	B650-03-020	B650-03-030	B650-01-040
3.37 inch o.d. CF	50 (2)	GVC020P	B651-03-020	B651-03-030	B651-01-040
4.47 inch o.d. CF	63 (2 1/2)	GVC025P	B652-03-020	B652-03-030	B652-01-040
6.00 inch o.d. CF	100 (4)	GVC040P	B653-03-020	B653-03-030	B653-03-040
8.00 inch o.d. CF	160 (6)	GVC060P	B654-03-020	B654-03-030	B654-03-040
10.00 inch o.d. CF	200 (8)	GVC080P	B655-03-020	B655-03-030	B655-03-040
12.00 inch o.d. CF	250 (10)	GVC100P	B656-03-020	B656-03-030	B656-03-040
14.00 inch o.d. CF	320 (12)	GVC120P	B657-03-020	B657-03-030	B657-03-040

Table 5 - Spares for GV Valves manufactured in 1993 to 1995

Flange size	Nominal bore: mm (inches)	Valve model	Seals Kits	Bellows Kits	Pins and bearings Kits
NW40	40 (1 1/2)	GVI040	B650-01-050	B650-01-060	B650-01-070
NW50	50 (2)	GVI050	B651-01-050	B650-01-060	B651-01-070
ISO63	63 (2 1/2)	GVI063	B652-01-050	B650-01-060	B652-01-070
ISO100	100 (4)	GVI100	B653-01-050	B653-03-060	B653-01-070
ISO160	160 (6)	GVI160	B654-01-050	B653-01-060	B654-01-070
ISO200	200 (8)	GVI200	B655-01-050	B653-01-060	B655-01-070
ISO250	250 (10)	GVI250	B656-01-050	B656-01-060	B656-01-070
ISO320	320 (12)	GVI320	B657-01-050	B656-01-060	B657-01-070
NW40	40 (1 1/2)	GVI040P	B650-01-050	B650-01-060	B650-01-070
NW50	50 (2)	GVI050P	B651-01-050	B650-01-060	B651-01-070
ISO63	63 (2 1/2)	GVI063P	B652-01-050	B650-01-060	B652-01-070
ISO100	100 (4)	GVI100P	B653-01-050	B653-01-060	B653-01-070
ISO160	160 (6)	GVI160P	B654-01-050	B653-01-060	B654-01-070
ISO200	200 (8)	GVI200P	B655-01-050	B653-01-060	B655-01-070
ISO250	250 (10)	GVI250P	B656-01-050	B656-01-060	B656-01-070
ISO320	320 (12)	GVI320P	B657-01-050	B656-01-060	B657-01-070
2 inch ANSI	50 (2)	GVA020	B651-01-050	B650-01-060	B651-01-070
2 inch ANSI	63 (2 1/2)	GVA025	B652-01-050	B650-01-060	B652-01-070
4 inch ANSI	100 (4)	GVA040	B653-01-050	B653-01-060	B653-01-070
6 inch ANSI	160 (6)	GVA060	B654-01-050	B653-01-060	B654-01-070
6 inch ANSI	200 (8)	GVA080	B655-01-050	B653-01-060	B655-01-070
10 inch ANSI	250 (10)	GVA100	B656-01-050	B656-01-060	B656-01-070
10 inch ANSI	320 (12)	GVA120	B657-01-050	B656-01-060	B657-01-070
2 inch ANSI	50 (2)	GVA020P	B651-01-050	B650-01-060	B651-01-070
2 inch ANSI	63 (2 1/2)	GVA025P	B652-01-050	B650-01-060	B652-01-070
4 inch ANSI	100 (4)	GVA040P	B653-01-050	B653-01-060	B653-01-070
6 inch ANSI	160 (6)	GVA060P	B654-01-050	B653-01-060	B654-01-070
6 inch ANSI	200 (8)	GVA080P	B655-01-050	B653-01-060	B655-01-070
10 inch ANSI	250 (10)	GVA100P	B656-01-050	B656-01-060	B656-01-070
10 inch ANSI	320 (12)	GVA120P	B657-01-050	B656-01-060	B657-01-070
2.37 inch o.d. CF	40 (1 1/2)	GVC015	B650-03-050	B650-03-060	B650-01-070
3.37 inch o.d. CF	50 (2)	GVC020	B651-03-050	B651-03-060	B651-01-070
4.47 inch o.d. CF	63 (2 1/2)	GVC025	B652-03-050	B652-03-060	B652-01-070
6.00 inch o.d. CF	100 (4)	GVC040	B653-03-050	B653-03-060	B653-03-070
8.00 inch o.d. CF	160 (6)	GVC060	B654-03-050	B654-03-060	B654-03-070
10.00 inch o.d. CF	200 (8)	GVC080	B655-03-050	B655-03-060	B655-03-070
12.00 inch o.d. CF	250 (10)	GVC100	B656-03-050	B656-03-060	B656-03-070
14.00 inch o.d. CF	320 (12)	GVC120	B657-03-050	B657-03-060	B657-03-070
2.37 inch o.d. CF	40 (1 1/2)	GVC015P	B650-03-050	B650-03-060	B650-01-070

Table 5 - Spares for GV Valves manufactured in 1993 to 1995 (continued)

Flange size	Nominal bore: mm (inches)	Valve model	Seals Kits	Bellows Kits	Pins and bearings Kits
3.37 inch o.d. CF	50 (2)	GVC020P	B651-03-050	B651-03-060	B651-01-070
4.47 inch o.d. CF	63 (2 1/2)	GVC025P	B652-03-050	B652-03-060	B652-01-070
6.00 inch o.d. CF	100 (4)	GVC040P	B653-03-050	B653-03-060	B653-03-070
8.00 inch o.d. CF	160 (6)	GVC060P	B654-03-050	B654-03-060	B654-03-070
10.00 inch o.d. CF	200 (8)	GVC080P	B655-03-050	B655-03-060	B655-03-070
12.00 inch o.d. CF	250 (10)	GVC100P	B656-03-050	B656-03-060	B656-03-070
14.00 inch o.d. CF	320 (12)	GVC120P	B657-03-050	B657-03-060	B657-03-070

7.4 Accessories

Note: The fittings on the following accessories are suitable for 6 mm diameter tube.

Accessory	Item Number
Lightweight 5-port electropneumatic control valve kits	
24 V a.c., 1-phase, 50/60 Hz	B287-03-030
110 V a.c., 1-phase, 50/60 Hz	B287-03-031
230 V a.c., 1-phase, 50/60 Hz	B287-03-032
24 V d.c.	B287-03-055