

Vacuum Solutions

Application Support

Service

GA 01.417/3.02

Chemtech Scientific provides access to this content as a courtesy.
We do not own the content contained in this document.
All rights and credit go directly to its rightful owners.
www.chemtechsci.com
Call us at: 484-424-9415

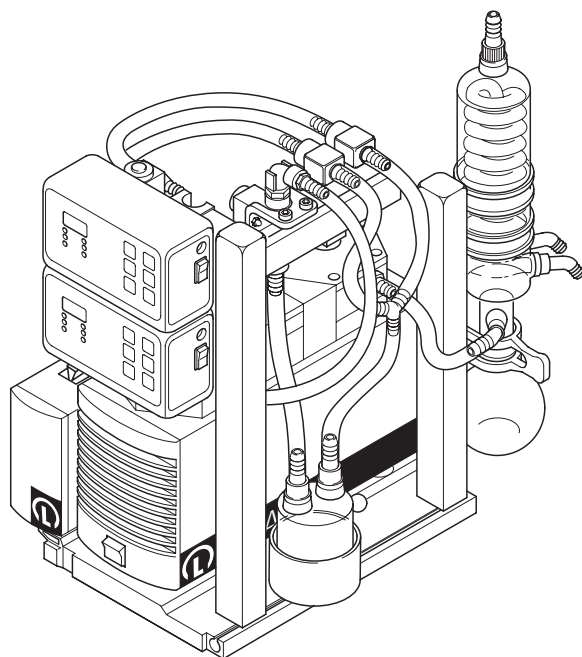

DIVAC 0.6 L; 1.2 L; 2.2 L

Laboratory Pump with Modular Accessories

Cat. Nos.:

135 00	135 61
135 01	135 62
135 02	135 63
135 03	135 70
135 04	135 71
135 06	135 72
135 07	135 73
135 08	135 80
135 09	135 81
135 10	135 82
135 12	135 83
135 13	135 85
134 14	135 87
135 15	135 90
135 16	135 91
135 40	135 92
135 50	135 93
135 60	

These Operating Instructions apply to all models of the DIVAC pump series and to all DIVAC pump systems SR..., SH..., SC... and SCC... as well as upgrade modules DIVATRONIC DT 1 and following.

Operating Instructions

Contents

	Page
1 Description	3
1.1 System versions	5
1.1.1 Vacuum pump with two separators (SR systems)	5
1.1.2 Vacuum pump with separator and high performance condenser (SH systems) ..	5
1.1.3 Vacuum pump with separator, high performance condenser and a vacuum controller DIVATRONIC DT 1 (SC systems) ..	6
1.1.4 Vacuum pump with separator, high performance condenser and two DIVATRONIC DT 1 controllers (SCC system) ..	6
2 Safety information	7
3 Operation	8
3.1 Operating conditions for the vacuum pumps of the DIVAC system	8
3.2 Operation of the pump system	8
3.2.1 Operation with baseplate and two separators ..	8
3.2.2 Operation with baseplate, separator and high performance condenser	10
3.2.3 Operation with baseplate, separator, high performance condenser, control unit and one DIVATRONIC DT 1 controller	11
3.3 Start up	14
3.3.1 Adjustment of the vacuum setpoint	14
3.3.2 Hysteresis adjustment	14
3.3.3 Automatic setpoint correction	14
3.3.4 Starting the evacuation process	14
3.3.5 Stopping the evacuation process	15
3.3.6 Restart after stopping a running evacuation process	15
3.3.7 Evacuation without control for maximum vacuum (drying mode)	15
3.3.8 Venting of the system	15
3.4 Operation with baseplate, separator, high performance condenser, control unit and two DIVATRONIC DT 1 (SCC)	16
3.4.1 Upgrading of existing DIVAC systems (SH/SC to SC/SCC) with DIVATRONIC modules	17
3.4.1.1 System with already present baseplate, separator and condenser (SH system)	17
3.4.1.2 System with already present baseplate, separator, condenser, control unit, support post and one DIVATRONIC DT 1 controller	17
3.5 Gas ballast option	19
3.6 Shut down	20
3.7 Troubleshooting	20
3.7.1 System without DIVATRONIC DT 1 controller (SH/SR systems)	20
3.7.2 System with one DIVATRONIC DT 1 controller	20
3.7.3 System with two DIVATRONIC DT 1 controllers (SCC systems)	21
3.8 Exchanging diaphragms and valves plates ..	21
4 Technical data	23
5 Ordering information	23
5.1 DIVAC pump system	23
5.2 Accessories for the modular DIVAC system ..	24
5.3 DIVATRONIC modules	25
6 Spare parts	26
EC Declaration of Conformity	29



Before putting the unit into operation you must read these Operating Instructions first. Observe the Operating Instructions while operating the unit in the sense of avoiding hazards and damage.

Warning



Indicates procedures that must be strictly observed to prevent hazards to persons.

Caution

Indicates procedures that must strictly be observed to prevent damage to, or destruction of the equipment.

Leybold Service

If a pump is returned to Leybold, indicate whether the pump free of substances damaging to health or whether it is contaminated.

If it is contaminated also indicate the nature of the hazard. Leybold must return any pumps without a "Declaration of Contamination" to the sender's address.

Figures

The references to figures, e.g. (1/2) consist of the Fig. No. and the item No. in that order.

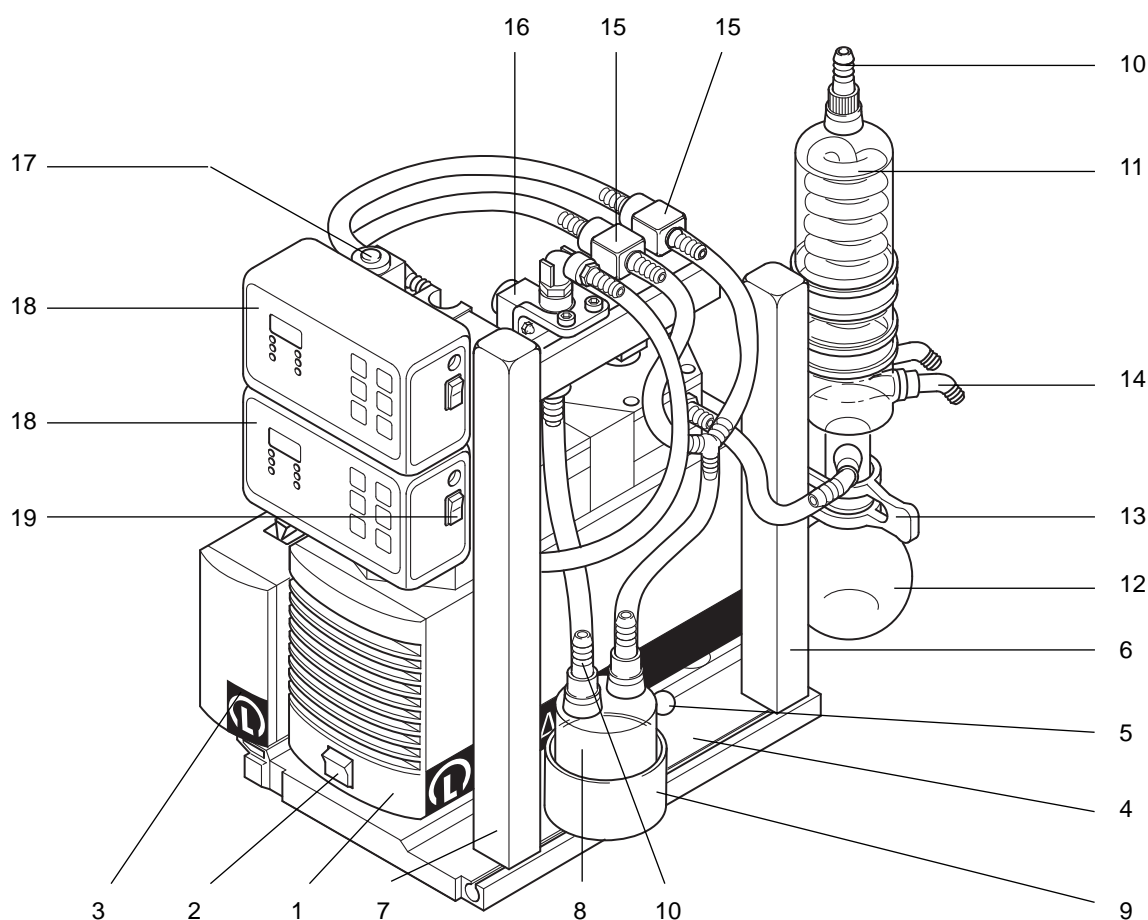
**Key to Fig. 1**

- | | |
|--|--|
| 1 Vacuum pump | 11 High performance condenser |
| 2 Mains switch | 12 Glass flask for condensate |
| 3 Control unit | 13 Attachment clamp |
| 4 Baseplate | 14 Angled hose nozzle for the cooling water connection |
| 5 Attachment rod for the pump | 15 Vacuum valve |
| 6 Support post for the condenser | 16 Pump relief valve |
| 7 Support post for the controller unit | 17 Venting valve at the DIVATRONIC DT 1 controller |
| 8 Separator | 18 Vacuum controller DIVATRONIC DT 1 |
| 9 Cup for the separator | 19 Mains switch of the vacuum controller DIVATRONIC DT 1 |
| 10 Hose nozzle | |

Fig. 1 Modular, fully equipped DIVAC system SCC 0.6 L - 1.2 L - 2.2 L

1 Description

This range of vacuum pumps has been specifically developed for use in the laboratory. Laboratory applications are particularly demanding with regard to precision, reliability and ease of operation.

The DIVAC range of vacuum pumps has been developed on the basis of the well proven technology of diaphragm pumps.

With three different pumping speeds and the same attainable ultimate pressure for each of these vacuum pumps and the modular accessories, the DIVAC pump system can be optimally adapted to meet individual requirements.

Examples of applications:

- Vacuum filtration
- Vacuum distillation
- Vacuum drying
- Vacuum impregnation
- on rotary evaporators
- for sucking and pumping of gases
- drying of gels

Features of the DIVAC Vacuum Pumps and the DIVAC System

- All system components are combined in one single assembly, which can easily be exchanged or upgraded up to the fully equipped SCC... version (with two DIVATRONIC DT 1 controllers).
- Simple to move to an other location, since the entire assembly is arranged on a rugged baseplate so that it can be moved safely.
- Because connectors are used throughout, individual components can be easily disassembled.
- Compact design – small footprint.
- Starting with version SC... with separator, high performance condenser and DIVATRONIC DT 1 controller, all electrical connections are combined via connectors at the control unit.
- The installation of further laboratory components in slots, on support posts and cross bars of the assembly is possible without problems.
- The diaphragms and valves on the vacuum pump can be easily exchanged.
- All parts of the pump's head which come into contact with the gas are capable of resisting aggressive media (material: PTFE, FFKM and PVDF).
- The vacuum pumps operate in a gas-tight manner, 100% free of oil, maintenance-free and silently.
- A new valve system provides a high level of compatibility with vapours and condensate.
- Low ultimate vacuum pressures are attained quickly.
- Illuminated mains switch on the pump.
- Overtemperature protection for the vacuum pump through a thermal overload protector.
- Pump systems can be arranged conveniently from DIVAC modules and DIVAC diaphragm pumps; four modules are available (see Section 5.2).

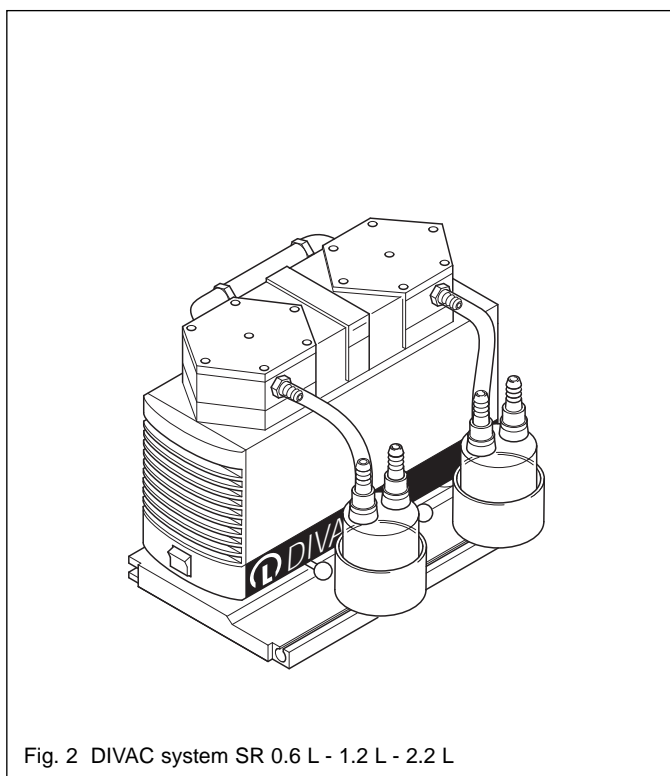

Fig. 2 DIVAC system SR 0.6 L - 1.2 L - 2.2 L

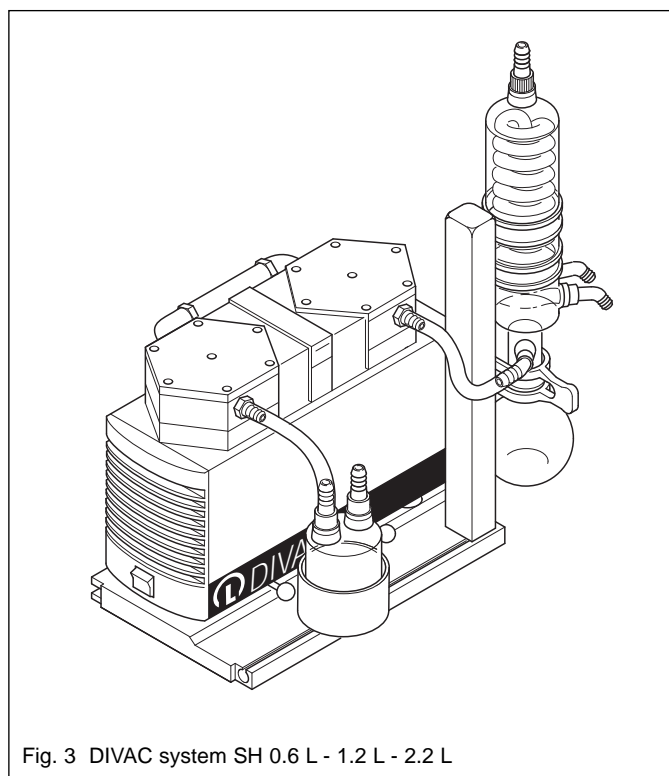

Fig. 3 DIVAC system SH 0.6 L - 1.2 L - 2.2 L

1.1 System Versions

Each of the three pump systems SR..., SH... and SC... which are supplied ready for operation can be upgraded in a modular way right up to the fully equipped SCC... system for two vacuum chambers. Also beginning with one pump you may upgrade to each of the systems. The DIVAC modules or the DIVATRONIC upgrades detailed in Section 5.2 are used for this.

For this refer to Section 3.

Ordering information is provided in Section 5.

1.1.1 Vacuum Pump with two Separators (SR Systems)

SR 0.6 L (pumping speed $0.6 \text{ m}^3 \cdot \text{h}^{-1}$)

SR 1.2 L (pumping speed $1.2 \text{ m}^3 \cdot \text{h}^{-1}$)

SR 2.2 L (pumping speed $2.2 \text{ m}^3 \cdot \text{h}^{-1}$)
consisting of DIVAC module SR and DIVAC diaphragm pump(s) (see Section 5.1 and subsequent sections)

Any solvent residues are separated on the pressure side so as to prevent them from entering into the ambient air. On the suction side, a separator collects any particles and droplets which might be present in the system. This prevents the pump from being contaminated and ensures peak pump performance.

The separating vessel is made of a special kind of glass and it is protected against implosion.

1.1.2 Vacuum Pump with Separator and High Performance Condenser (SH Systems)

SH 0.6 L (pumping speed $0.6 \text{ m}^3 \cdot \text{h}^{-1}$)

SH 1.2 L (pumping speed $1.2 \text{ m}^3 \cdot \text{h}^{-1}$)

SH 2.2 L (pumping speed $2.2 \text{ m}^3 \cdot \text{h}^{-1}$)
consisting of DIVAC module SH and DIVAC diaphragm pump(s) (see Section 5.1 and subsequent sections)

The high performance condenser is employed to recover solvents from the pumped gas in order to conserve resources and to protect the environment.

The condensed solvents are collected in a glass flask. The flask itself is attached by means of a clamp to the flange of the condenser.

Through the use of a recirculation cooler the efficiency of condensation may be increased considerably.

Refrigerant temperatures of $5 \text{ }^\circ\text{C}$ are optimum for efficient condensation and the resulting reduction of emissions.

Recirculation thermostats free of HCFCs are available from us upon request.

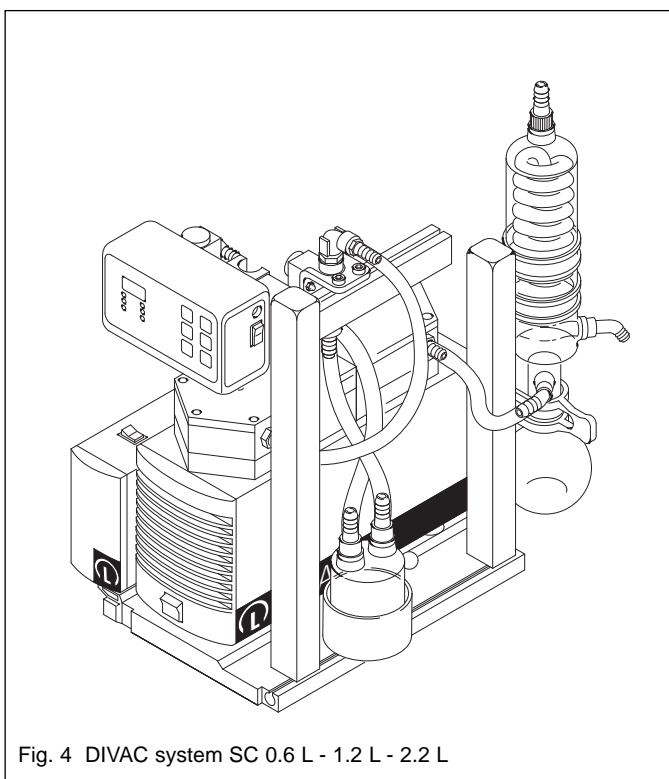

Fig. 4 DIVAC system SC 0.6 L - 1.2 L - 2.2 L

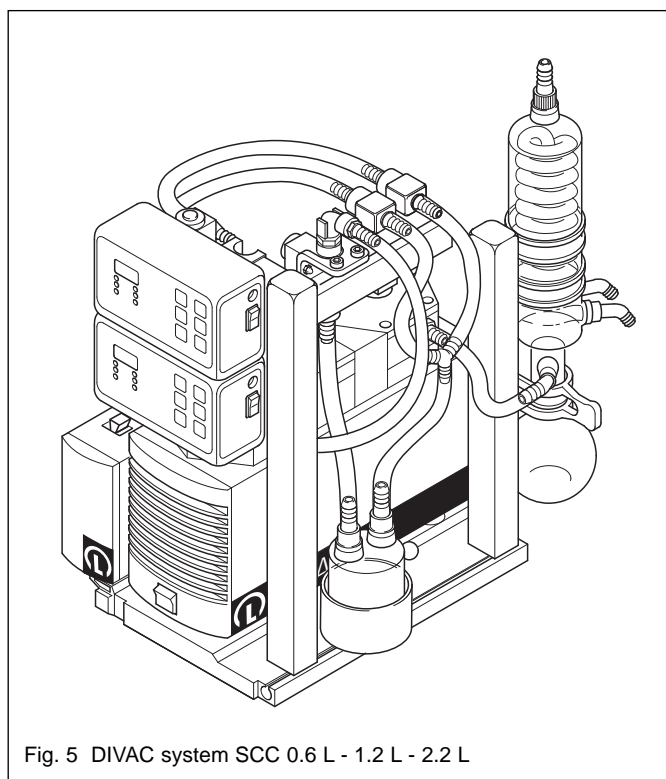

Fig. 5 DIVAC system SCC 0.6 L - 1.2 L - 2.2 L

1.1.3 Vacuum Pump with Separator, High Performance Condenser and a DIVATRONIC DT 1 Controller (SC Systems)

SC 0.6 L (pumping speed $0.6 \text{ m}^3 \cdot \text{h}^{-1}$)

SC 1.2 L (pumping speed $1.2 \text{ m}^3 \cdot \text{h}^{-1}$)

SC 2.2 L (pumping speed $2.2 \text{ m}^3 \cdot \text{h}^{-1}$)
consisting of DIVAC module SC and DIVAC diaphragm pump(s) (see Section 5.1 and subsequent sections)

In conventional laboratory systems the vacuum pump is running all the time at its ultimate pressure.

However, in systems with a DIVATRONIC DT 1 controller the vacuum pump is always switched off as soon as the set pressure level has been attained. The data and commands are entered via push-buttons.

Features of the vacuum controller DIVATRONIC DT 1:

- Simple entry through keying in the process parameters setpoint and hysteresis for the vacuum.
- Exact reproducibility of the entered parameters.
- Interruption of the evacuation process is possible at any time.
- In the DIVAC system with one DIVATRONIC DT 1 controller, the strain is automatically taken away from the pump by venting it to atmospheric pressure. This increases the service life of the pump and reduces the noise level.

- Simple venting of the connected vacuum chamber via the key pad.
- Switchover from regulated evacuation to maximum vacuum through a single key stroke.
- In case of a power failure the currently active values are retained.
- **DIVATRONIC DT 1**
230 V, 50 Hz Cat. No. 161 17
115 V, 60 Hz/100 V, 50/60 Hz Cat. No. 896 17

1.1.4 Vacuum Pump with Separator, High Performance Condenser and two DIVATRONIC DT 1 Controllers (SCC Systems)

SCC 0.6 L (pumping speed $0.6 \text{ m}^3 \cdot \text{h}^{-1}$)

SCC 1.2 L (pumping speed $1.2 \text{ m}^3 \cdot \text{h}^{-1}$)

SCC 2.2 L (pumping speed $2.2 \text{ m}^3 \cdot \text{h}^{-1}$)
consisting of DIVAC module SCC and DIVAC diaphragm pump(s) (see Section 5.1)

Through a second DIVATRONIC DT 1 controller it is possible to only use one vacuum pump to run two different processes at the same time and independently.

Warning When running two processes at the same time, you must ensure that the corresponding media are compatible with each other.
Please observe the applicable accident



2 Safety Information

Warning prevention regulations as well as all other generally accepted safety and health protection regulations.

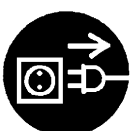

Housing parts which are marked with this symbol must only be opened after having pulled the mains plug (interruption of the electrical power supply connection).

Housing parts which contain voltage carrying components inside must only be opened by trained personnel.

- Always keep the Operating Instructions close at hand near to the unit.
- Note that the pump system and all system parts must only be used for the purpose they are intended for.
- Only connect the unit to properly installed mains outlets with a ground conductor.
- During all cleaning work make sure that no liquids enter inside the housing.
- All three types of pump are protected against overheating by a thermal overload protector. If this protector has responded or if the power has failed, pull the mains plug so that the pump can not start up again in an uncontrolled manner.
- Only use original spare parts from Leybold.
- Never expose any part of your body to the vacuum.

When installing the vacuum pump or the DIVAC system, please observe the following:

- Select a secure place for the unit (flat surface).
- Make sure that the vacuum pump is securely attached to the baseplate (for installation information see Section 3.2, Fig. 7 and subsequent figures). The two ball pins (8/2) under the pump must be firmly engaged.
- Laboratory devices or additional components which are connected to a DIVAC pump or a DIVAC system must have the same pneumatic rating as the pumps.
- Operation of the high performance condenser requires a cold water connection or a recirculating cooler.
- The condenser must only be fitted at the discharge side of the pump; if fitted on the intake side there exists the risk of implosion.

- In case of simultaneous operation involving two different gases, only such gases must be pumped which can be mixed without danger.
- Do not operate the pump in explosion-hazard environments.
- Processes involving radioactive exposure should be avoided.

Before starting up

- Observe the safety regulations for the use of:
 - acid,
 - explosive,
 - microbiological,
 - radioactive,
 - toxic media and other dangerous substances.
- Lead the external connection hoses on the suction side to the vacuum chamber and on the pressure side to the waste disposal unit or the discharge unit.
- Ensure that the upper gas discharge outlet on the condenser is not blocked (danger of an overpressure as a result of a bent hose, for example).
- Make sure that the outlet of the pump is not sealed or narrowed.
- Lay the connecting hoses for cooling the condenser between condenser and water supply and drain.
- Before switching on check the seating of all hose connections first.
- Compare the locally available mains voltage to the data provided on the name plate.
- Never operate the pump with the sealing stopper (red plastic cap) in place at the pump's outlet while the inlet is open at the same time.
- Already before commissioning the pump remove the plastic caps. Otherwise there exists the danger that someone may be injured by caps ejected off from the pump.

3 Operation

3.1 Operating Conditions for the Vacuum Pumps of the DIVAC System

- Permissible ambient temperatures: +5 °C to + 40 °C.
- Pumping of liquids is not permissible.
- Permissible temperatures for the gases which are to be pumped: +5 °C to + 40 °C.
- The pump must never be started up against an overpressure (on the pressure side).
- During standstill (power failure, for example) the pump must be pneumatically relieved. In the case of pump systems (SC/SCC) with a DIVATRONIC DT 1 controller, the pump is relieved automatically through the relief valve.
- Any throttling or control of quantity of the air or gas should only be done in the line on the suction side. If throttling or control is only possible on the pressure side, you must not exceed the max. overpressure specification of the pump in each case.
- In order to ensure adequate cooling of the pump, the ventilation slits on the vacuum pump must not be obstructed.
- The vacuum pumps may also be operated continuously at their ultimate pressure.

3.2 Operation of the Pump System

- The pump is switched on or off through the mains switch (see Fig. 1, item 2).
- In case of operation with one or more DIVATRONIC DT 1 controllers:

The DIVATRONIC DT 1 controller(s) is/are switched on and off through the mains switch (1/19).

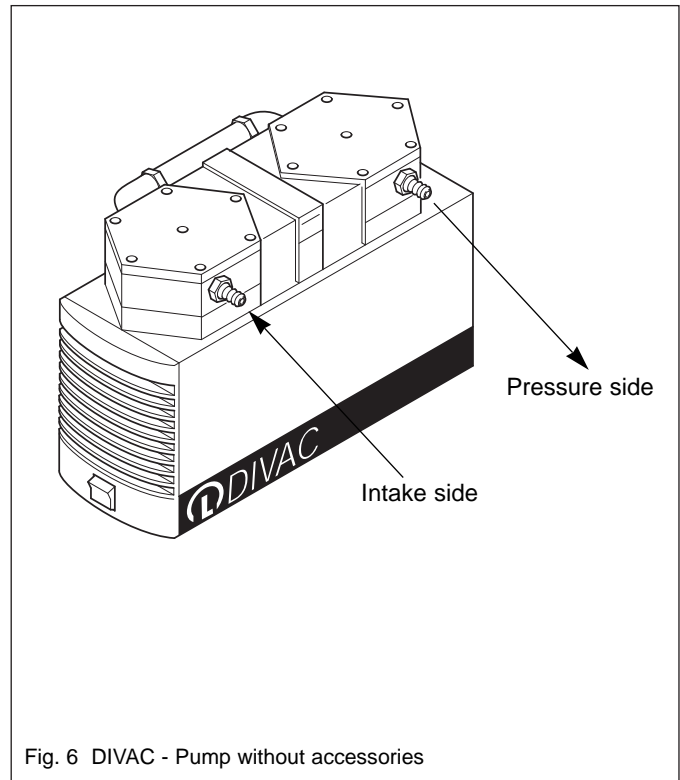

Fig. 6 DIVAC - Pump without accessories

3.2.1 Operation with Baseplate and two Separators

Corresponds to the DIVAC system SR... (see Section 2).

The Baseplate

- The basis for the DIVAC assembly is a pump in connection with a baseplate.
- The mounting system ensures that the individual pump models seated on the baseplate can be exchanged without problems (see Fig. 5).
- Fixing the pump to the baseplate:

Place the pump with its fixing components on the baseplate and align the pump.

Insert the two fixing rods through the fixing components of the pump and the baseplate.

Make sure that the ball pins (8/2) engage positively.

Warning Before exchanging the pumps, the pump which has been attached to the baseplate must be disconnected from the mains by pulling the mains plug.



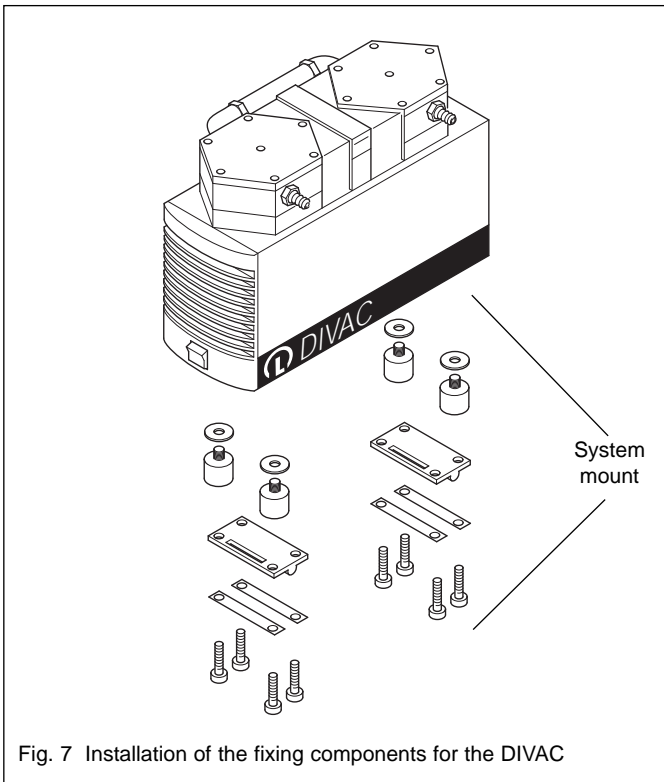

Fig. 7 Installation of the fixing components for the DIVAC

Installation / Upgrading

In order to be able to attach a pump on the baseplate, a system mount must be attached to the pump first.

In the case of the DIVAC system modules (SR/SH/SC/SCC) this system mount has already been attached in the factory. When ordering baseplates separately (see Section 5.3 – Accessories for the modular DIVAC system), the system mounts are included. They are installed according to Fig. 7.

- Unscrew the rubber feet under the pump by turning these in the anti-clockwise direction.
- Attach the system mount to the pump according to Fig. 7.

The Separator

- The cups for the separator vessels may be shifted as required after loosening the fixing screw.

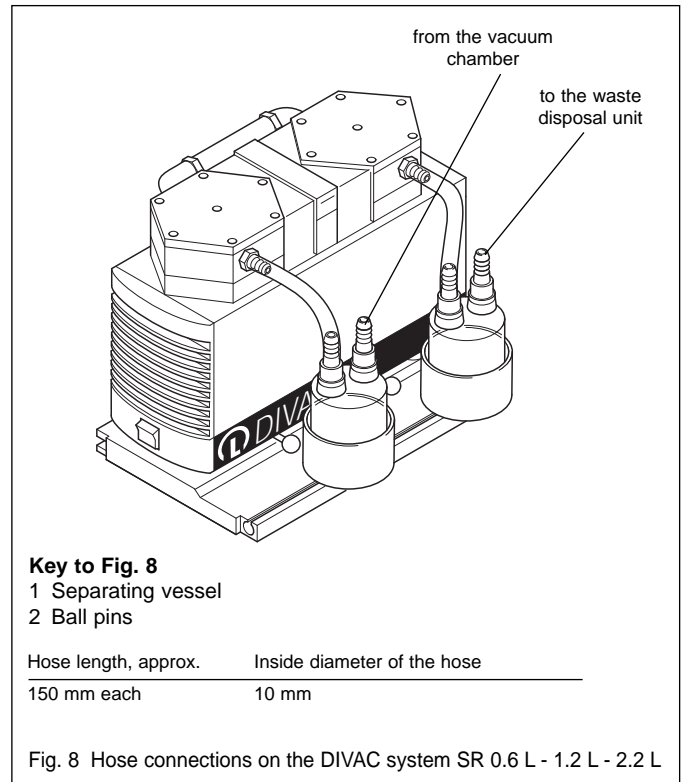

Key to Fig. 8

- 1 Separating vessel
- 2 Ball pins

Hose length, approx.	Inside diameter of the hose
150 mm each	10 mm

Fig. 8 Hose connections on the DIVAC system SR 0.6 L - 1.2 L - 2.2 L

Installation

- Insert the cups for the separator vessels into the slot pointing upwards on the baseplate.
- Affix the vessels by clamping:
Tighten the fixing screw in the bottom of the cup.
- Provide the hose connections according to Fig. 8 (for hose materials see Section 6 - Spare Parts).

Caution Use only such a hose material which is able to resist the kind of media used.

Emptying / Cleaning of the Separator

- Unscrew the two connection nozzles.
- Take the separator vessel out of its cup, properly dispose of the contents and rinse the vessel.
- Place the vessel back in its cup.
- Screw the connection nozzles back on.

The gas hoses connected to the connection nozzles on the separator vessels may be interchanged.



Ensure that the upper gas discharge of the condenser is not blocked (danger of an overpressure as a result of a bent hose, for example).

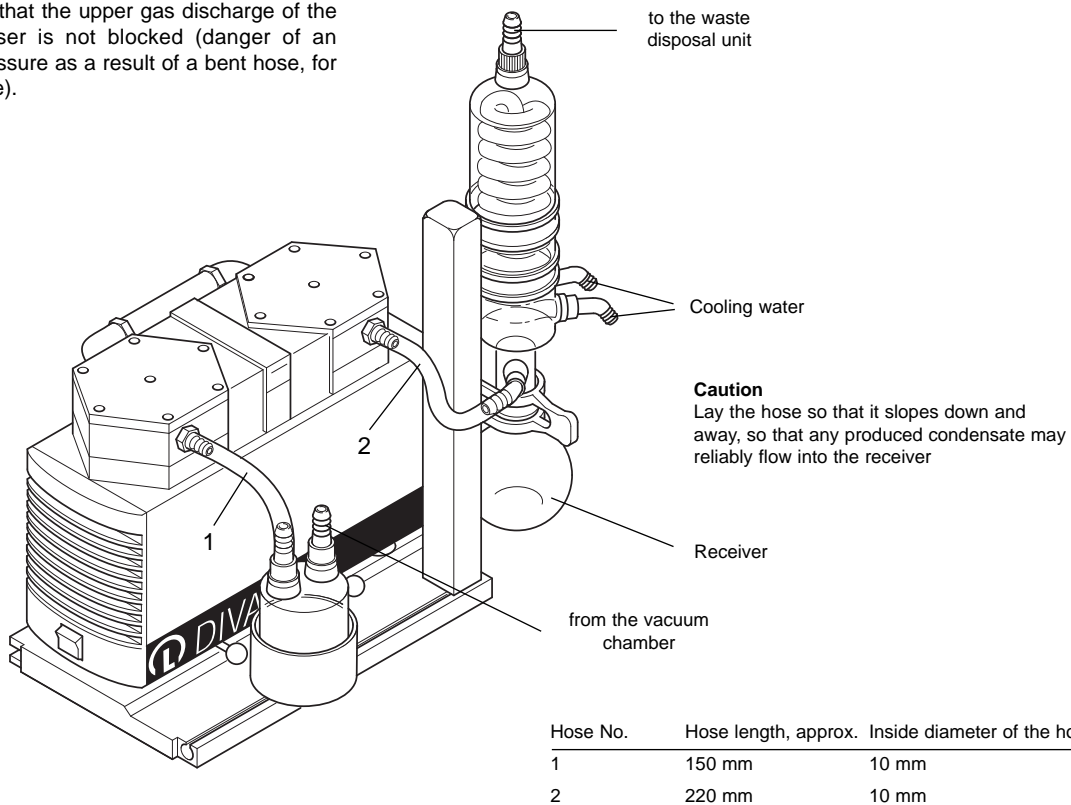

Fig. 9 Hose connections on the DIVAC SH system

3.2.2 Operation with Baseplate, Separator and High Performance Condenser

- Corresponds to DIVAC system SH... (see also Fig. 3), consisting of DIVAC module SH and DIVAC diaphragm pump(s), see Section 5.1 and subsequent sections.

The baseplate (see Section 3.2.1)

The separator (see Section 3.2.1).

The high performance condenser (see Section 3.2.2).

- In case of operation with the high performance condenser, a cold water connection or a recirculating cooler is required.

Installation of the condenser:

- Required tools:
 - 1 hex. socket wrench 5 mm.
- The high performance condenser is supplied attached to the support post.
- The support post (its fixing section) is pushed into a slot pointing up on the baseplate so that the screws for attaching the condenser point in the direction of the pump.

- Fix the support post to the baseplate (by tightening the hex. socket screw of the support post).
- Provide the hose connections as shown in Fig. 9 (for hose materials see Section 6 - Spare parts).
- For installing the DIVAC pump, see Section 3.2, Fig. 7.

Caution Use only such a hose material which is able to resist the kind of media used.

- The angled hose nozzles for the cooling water connection have been designed to accept hoses having an inside diameter of 8 mm.
- In the case of the condenser you must make sure that the hose connections for gas and cooling water (Fig. 9) are assigned correctly. The inlet and the outlet for the (gas) connections must not be interchanged.
- When providing the hose connections, take care that the hose connection for the condensate inlet (gas) is placed lower than that for the pump outlet. Thus possibly produced condensate can not enter the pump head.
- The cooling water supply and discharge lines may be connected as convenient to the two hose nozzles.

Key to Fig. 10

- 1 Pump relief valve
- 2 Connection "SOL.2" on the DIVATRONIC DT 1 controller
- 3 Connection "PRV" on the control unit
- 4 Connection "V.IN. 1" on the control unit
- 5 Mains socket with protective ground for DIVATRONIC DT 1 "Controller A"
- 6 Mains connection

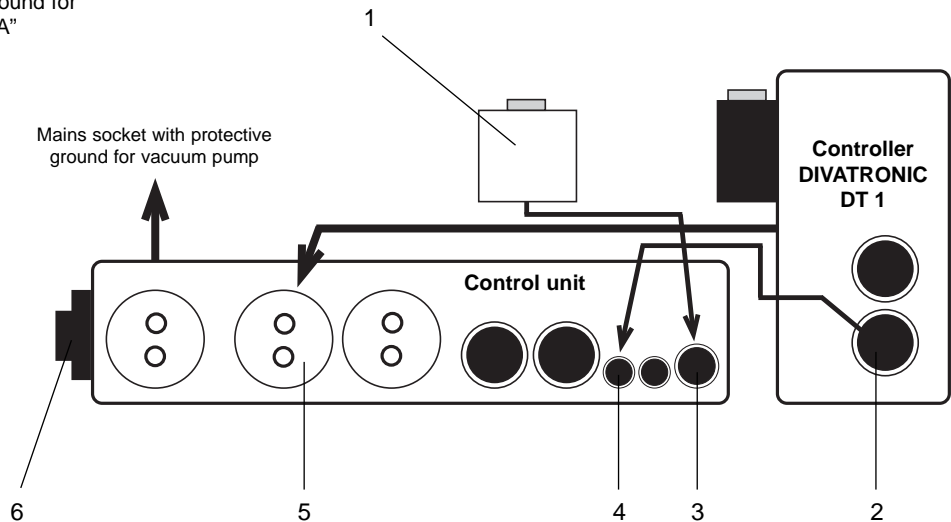

Fig. 10 Connections between DIVATRONIC DT 1 controller and control unit DIVAC system SC 06 L - 1.2 L - 2.2 L (Euro version)

Emptying / cleaning the condenser

- Carefully pull off the coloured holding clip while at the same time taking hold of the flask.
- Empty the glass flask and clean it. Observe the applicable safety regulations.
- Fit the glass flask back in place and push the coloured clip back on.

Height adjustment of the condenser

- Loosen the two hex. socket screws on the support post for the condenser.
- Move the condenser mount along the slot in the support post to the desired position.
- Tighten the hex. socket screws.

3.2.3 Operation with Baseplate, Separator, High Performance Condenser, Control Unit and one DIVATRONIC DT 1 Controller

- Corresponds to DIVAC system SC... (see Fig. 4).

The baseplate (see Section 3.2.1)

The separator (see Section 3.2.1).

The high performance condenser (see Section 3.2.2).

The vacuum controller DIVATRONIC DT 1

Through the DIVATRONIC DT 1 vacuum controller it is possible to control vacuum processes which require a well defined vacuum. Data and commands which are entered via the key pad precisely control the vacuum in a reproducible manner and in such a way that the vacuum can be influenced at any time.

The following can be entered and constantly controlled:

- Setpoint vacuum pressure.
- Setpoint hysteresis in "mbar" or "%".

The control unit

The control unit is run in connection with the DIVATRONIC DT 1 vacuum controller (or with two DIVATRONIC DT 1 vacuum controllers in the case of model SCC, see Section 3.4) to switch the pump off as soon as the entered setpoint has been attained and to switch the pump on. A pump relief valve is provided ahead of the pump so that the pump can be pneumatically relieved. This valve separates the pump from the vacuum chamber so that the pump may run up without a load by venting of hose line (11/3).

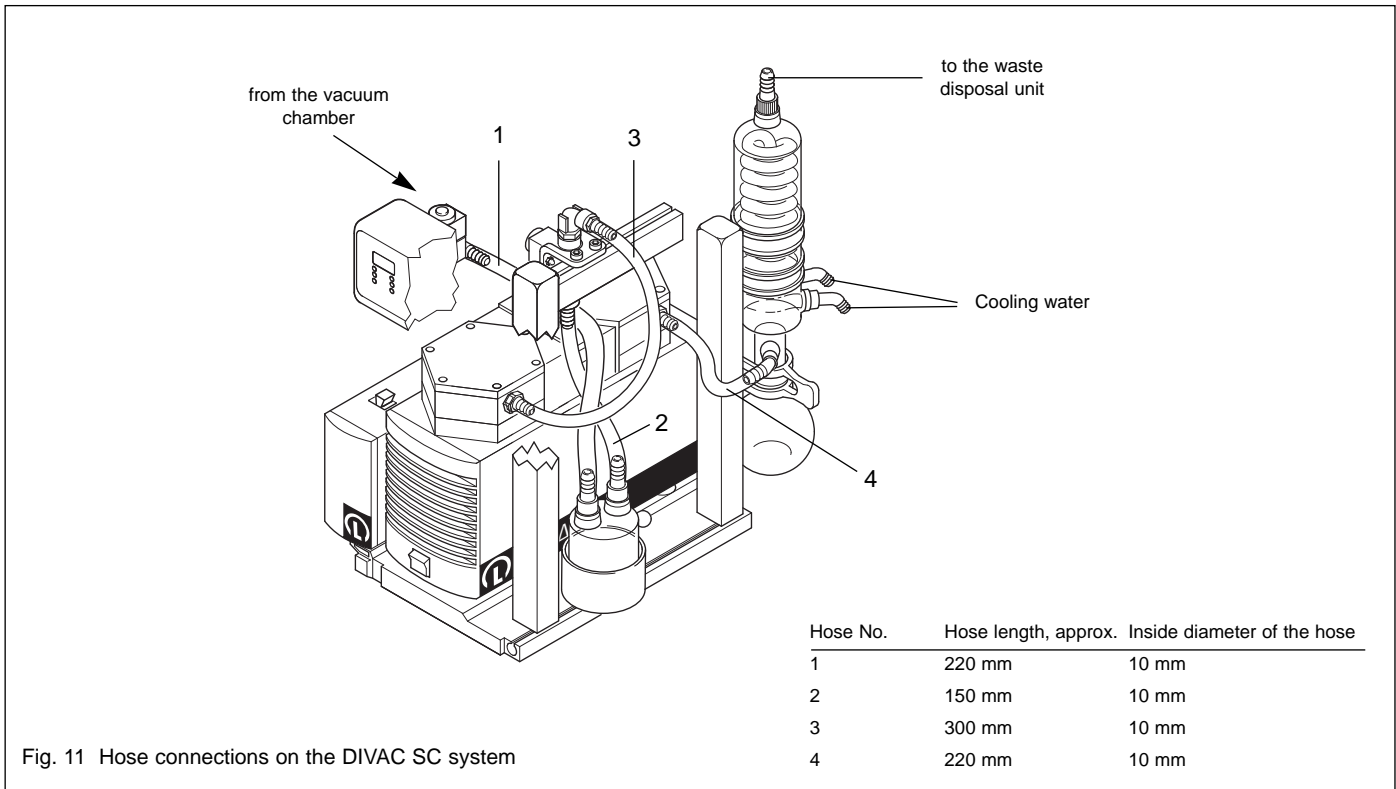

Fig. 11 Hose connections on the DIVAC SC system

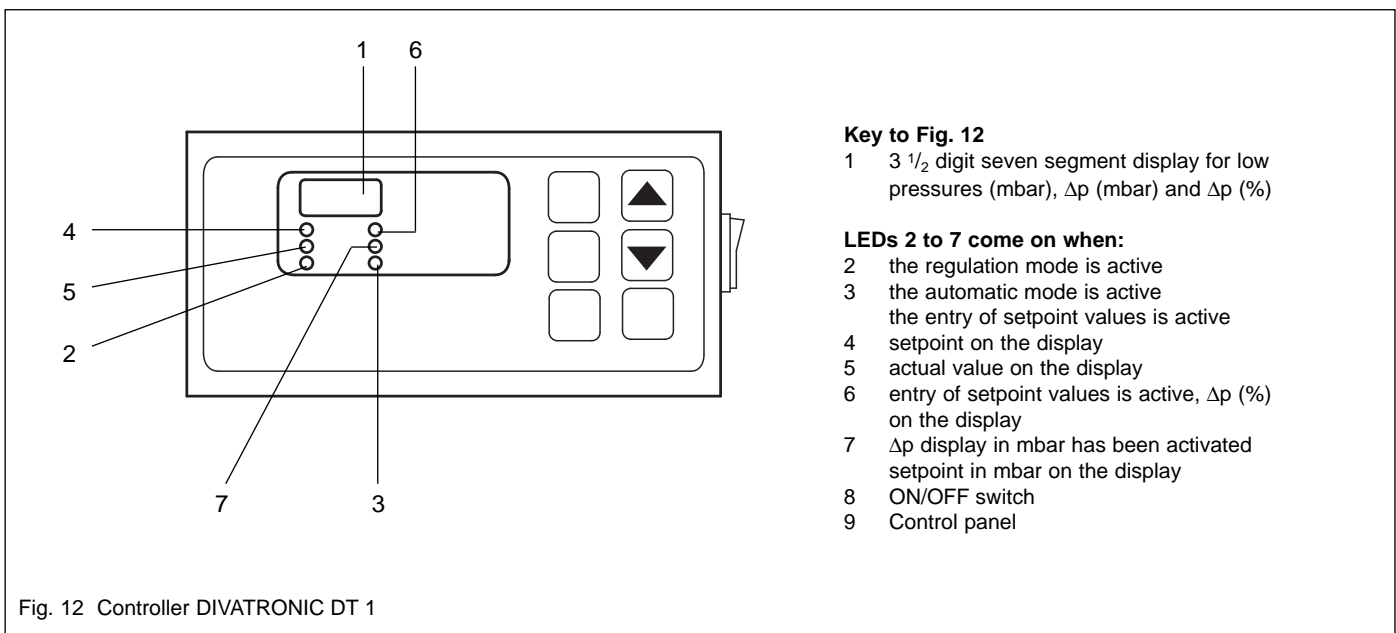

Fig. 12 Controller DIVATRONIC DT 1

Installation of DIVATRONIC DT 1 controller and control unit

For this refer to Fig. 1.

- Required tools:
1 hex. socket screw key 4 mm and 5 mm
- Controller DIVATRONIC DT 1 including venting valve and pump relief valve are supplied already fitted to the support post.

- Attach the control unit to the slot at the side on the baseplate.
 - Insert the two tightening nuts which have been fitted to the control unit by shifting the control unit.
 - Tighten by tightening the two hex. socket screws at the base of the control unit.

Installation of the support post together with DIVATRONIC DT 1 controllers and valves

- Insert the support post (attachment section) into the slot at the side pointing up on the baseplate (for alignment see Fig. 4).
- Tighten the support post by tightening the hex. socket screw located in the slot at the support post.
- For hose connections refer to Fig. 11 (for hose materials see Section 6 - Spare Parts).

Caution Use only such a hose material which is able to resist the kind of media used.

Electrical wiring and connections.

- Controller DIVATRONIC DT 1 with control unit:
Connect DIVATRONIC DT 1 controller connection SOL.2 to the connection “V.IN. 1” on the control unit using the supplied cable (see Fig. 10).
Plug the mains plug of the DIVATRONIC DT 1 controller into the corresponding mains socket on the control unit (see Fig. 10).
- Pump relief valve with control unit:
Insert the plug on the cable for the pump relief valve into socket “PRV” on the control unit (see Fig. 10).
- Pump with control unit:
Insert the mains connector of the pump into the marked mains socket on the control unit (see also Fig. 10).
For proper operation of the entire system it is absolutely necessary that the mains connection of the pump be provided through this socket with protective ground conductor.
- Control unit to the mains:
Insert the mains plug with protective ground conductor on the mains cable of the control unit into a properly installed mains socket with connected protective ground conductor.

Before starting the pump system check the following:

- all clamped connections for tightness,
- all hose connections as to whether they are connected at the right places,
- all wiring as to whether it is connected at the right places.

Key pad on the DIVATRONIC DT 1 controller

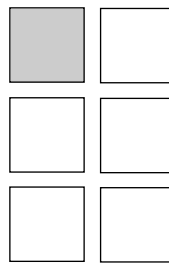

“Display” push-button

Changes the read out in the regulation mode between “actual value in mbar” and “setpoint in mbar”. Switches automatically to “Act. Value” after 10 s.

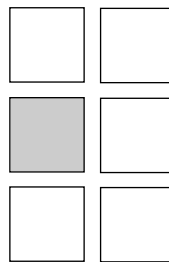

“Auto” push-button

Automatic setpoint correction (see Section 3.3.3).

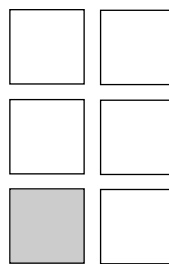

“Δp” push-button

Adjustment of hysteresis (see Section 3.3.2).

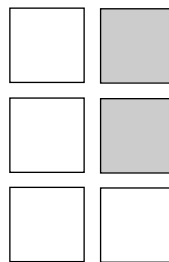

“Up” push-button

Setpoint or Δp

“Δown” push-button

Setpoint or Δp

- toggle: single steps
- keep depressed: running numbers

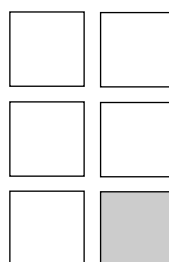

“Start/Stop” push-button

– toggle: activate

(Regulation mode)

– keep depressed:

for venting and evacuation without regulation.

3.3 Start Up

Setting the limit value for venting.

Irrespectively of the height above sea level at which the unit is operated, this setting will ensure that the unit switches off reliably also in the event of an overpressure at the inlet of the venting valve.

- Set the mains switch on the DIVATRONIC DT 1 controller to "I".
 - The display flashes for 5 seconds and will then indicate the value which was entered last (factory default: 1020 mbar).
- During the 5 second period the "Up/Down" push-button may be operated to enter the limit value (this value should be about 5 to 8 mbar above the prevailing atmospheric pressure).
- 5 seconds after the "Up/Down" push-button has been operated for the last time the unit will store the newly entered limit value.

3.3.1 Adjustment of the Vacuum Setpoint

- Set the mains switch on the pump to "EIN" ("ON").
- Set the mains switch on the DIVATRONIC DT 1 controller to "I".
 - The "Setpoint" indicator will come on or flash.
- Enter the required setpoint by operating the "Up" and "Down" push-buttons.
- Press the "Start/Stop" push-button briefly.
 - The setpoint has now been stored – the process is running.

or

when the pump has already evacuated and if a momentary actual value for the vacuum pressure is to be retained:

- operate the "Down" push-button as soon as the desired actual value is displayed - the setpoint is then stored.

The current setpoint remains stored in the memory even after switching the system off.

3.3.2 Hysteresis Adjustment

In the case of the hysteresis function that pressure above the setpoint is programmed in addition to the setpoint itself, at which the pump must cut in again. This can be done through the entry of a percentage or directly through the entry of a pressure difference (in mbar).

- Set the mains switch on the pump to "EIN" ("ON").
- Set the mains switch on the DIVATRONIC DT 1 controller to "I".

- The "Setpoint" indicator will come on or flash.
- Select the required mode (% or mbar) by operating the Δp push-button one or three times respectively.
 - The corresponding display will come on.
- Enter the desired Δp value by operating the "Up/Down" push-buttons.
- Press the "Start/Stop" push-button briefly.
 - The Δp value has now been stored.

The current Δp value remains stored in the memory even after switching the system off.

3.3.3 Automatic Setpoint Correction

(Automatic stepping)

The automatic setpoint correction facility will only function when the value which is entered for Δp (see Section 3.3.2) is equal to, or greater than 3 %.

If, after having entered the setpoint (see Section 3.3.1) the vacuum pump switches too often, operation of the "Auto" push-button will automatically correct the setpoint.

The setpoint is readjusted in max. 10 steps of 5 mbar each, whereby a step will occur as soon as the pump switches on at least twice after a time interval of 8 seconds has elapsed.

If the switching frequency is still too high after stepping through the 10 steps (+ 50 mbar), this will be indicated by a slowly flashing display. Pressing the "Auto" push-button once more will start the automatic stepping process again.

With the "Auto" push-button, the automatic stepper is switched on and off in the regulation mode. The automatic stepper remains activated also after venting the system (see Section 3.3.8) and can be switched off as required through the "Auto" push-button.

3.3.4 Starting the Evacuation Process

(For stopping the evacuation process refer to Section 3.3.5).

- Set the mains switch on the pump to "EIN" ("ON").
- Set the mains switch on the DIVATRONIC DT 1 controller to "I".
 - The "Setpoint" indicator will flash or come on.
 - The display will indicate the setpoint which was entered last.
- Briefly operate the "Start/Stop" push-button.
 - The display will indicate the actual value for the vacuum.
 - Indicator "Act. Value" is on.

- Indicator “Regulation Mode” is on.
- Pump starts up and keeps running until the entered setpoint has been reached.

3.3.5 Stopping the Evacuation Process

An evacuation process which is currently in progress trying to attain the entered setpoint can be terminated at any time:

- Briefly operate the “Start/Stop” push-button.
 - The display will indicate the setpoint.
 - The “setpoint” indicator flashes.

3.3.6 Restart after Stopping a Running Evacuation Process

- Briefly operate the “Start/Stop” push-button.
 - The display will indicate the actual value for the vacuum.
 - Indicator “Act. Value” is on.
 - Indicator “Regulation Mode” is on.

3.3.7 Evacuation without Control for Maximum Vacuum (Drying Mode)

Running of the drying mode is recommended after completion of the process in order to remove any condensate which possibly may have collected in the diaphragm heads.

If a higher vacuum pressure is required than the vacuum pressure currently selected or when wanting to run the drying mode:

- Briefly operate the “Start/Stop” push-button.
 - The “setpoint” indicator flashes.
- Press the “Start/Stop” push-button until the “Regulation Mode” indicator is erased.
 - Indicator “Act. Value” is on.
- Stop the evacuation process by operating the “Start/Stop” push-button briefly.

3.3.8 Venting of the System

If the vacuum system is to be vented or when wanting to apply inert gas:

- Press the “Start/Stop” push-button until the venting valve responds.
 - Pump is not running.
 - The display will continuously display the actual value of the vacuum.
 - Indicator “Act. Value” is on.
 - After pressure equalisation this display will

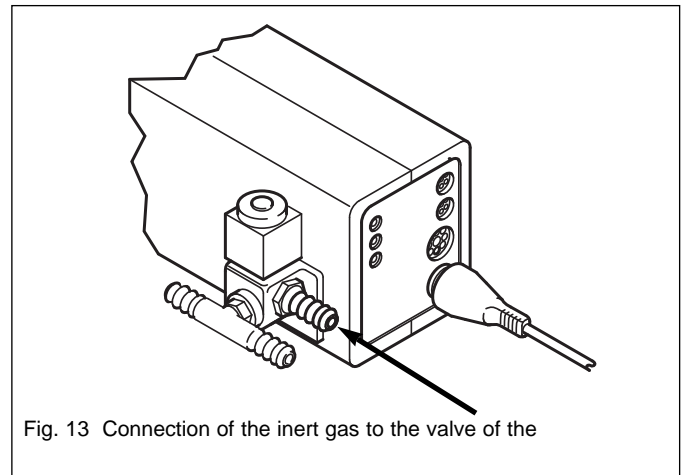

Fig. 13 Connection of the inert gas to the valve of the

change to indicate the setpoint.

- The “Setpoint” indicator is on.

The pressure for the inert gas supply must not exceed an overpressure of 0.3 bar.

Caution

Option: Cooling water valve for the high performance condenser

When interrupting the regulation mode of the DIVAC system by operating the “Start/Stop” push-button on the DIVATRONIC DT 1 controller or when terminating this mode, the cooling water will normally continue to run through the high performance condenser. The flow of the cooling water may be stopped with the aid of a cooling water valve.

When using a recirculating thermostat please observe the information provided in the Operating Instructions for the particular recirculation thermostat.

Installation:

- Connect the cooling water valve to the water supply.
- Connect the signal cable from the cooling water valve to the socket “SOL. 1” on the DIVATRONIC DT 1 controller.
- Cooling water valves are available from us upon request.

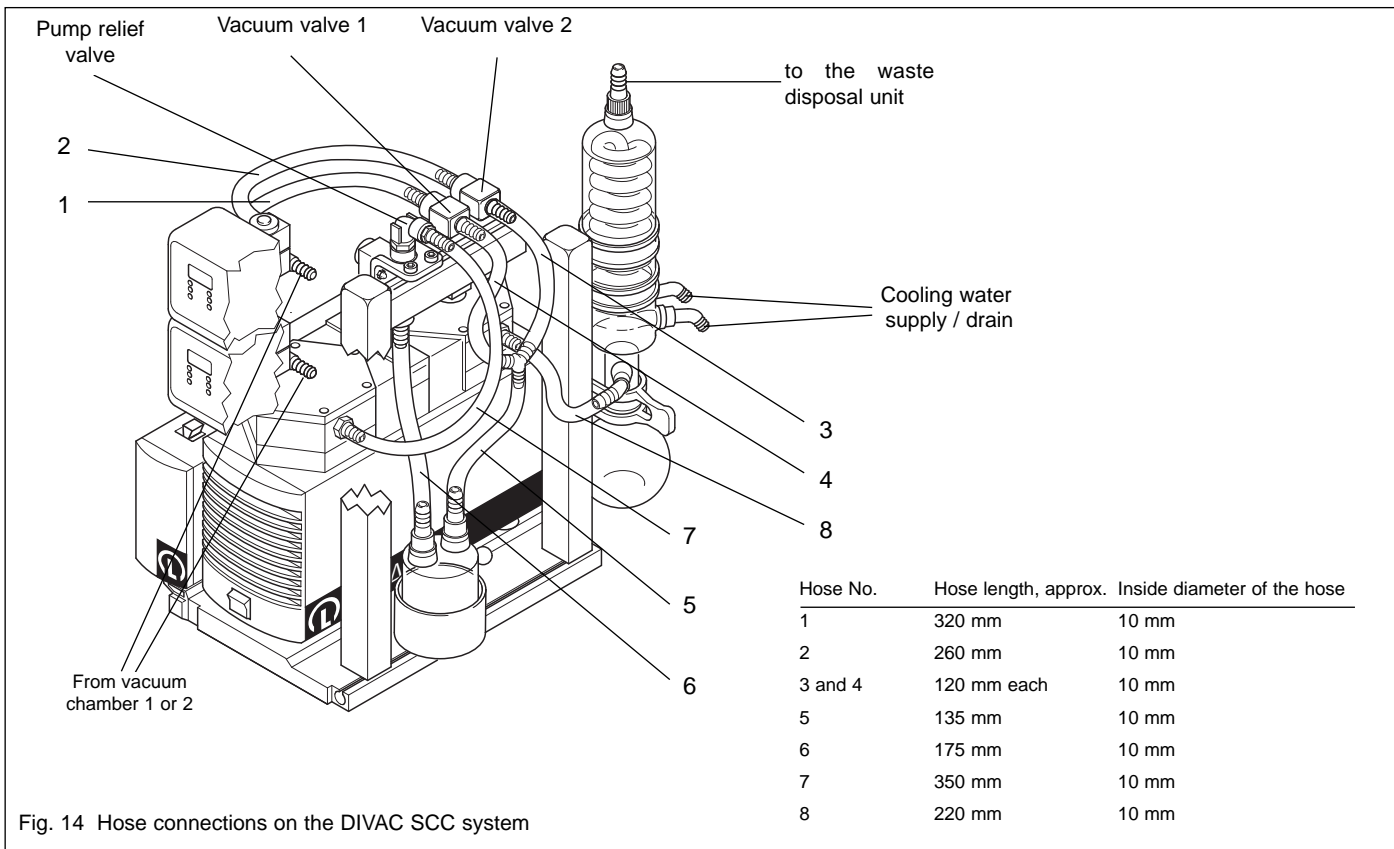

Fig. 14 Hose connections on the DIVAC SCC system

3.4 Operation with Baseplate, Separator, High Performance Condenser, Control Unit and two DIVATRONIC DT 1 (SCC)

Warning Within the system only such gases may be pumped together which can be mixed without problems.



The baseplate (see Section 3.2.1).

The separator (see Section 3.2.2).

The high performance condenser (see Section 3.2.2).

The control unit (see Section 3.2.3).

The DIVATRONIC DT 1 controller (see Section 3.2.3).

In the case of the pump system with two DIVATRONIC DT 1 vacuum controllers, two different processes can be controlled and monitored simultaneously and independently of each other. This is possible through two vacuum valves which are each controlled by a DIVATRONIC DT 1 vacuum controller.

Operation of each DIVATRONIC DT 1 controller does not differ from the operation of a single DIVATRONIC DT 1 controller (see Section 3.2.3). Each DIVATRONIC DT 1 controller operates independently of the other controller and all settings are separate.

As soon as the setpoint on one DIVATRONIC DT 1 controller has been attained, the valve which is controlled by that controller closes, whereby the pump continues the evacuation process until the setpoint which has been entered on the second DIVATRONIC DT 1 controller is attained. The second vacuum valve closes, the pump is switched off and the pump relief valve opens.

After the two vacuum pressures have decreased, the pump will cut in as soon as one of the hysteresis ranges has been exceeded.

Otherwise operation is the same as for the systems which are equipped with only one DIVATRONIC DT 1 controller (SC systems) see Section 3.2.3 and subsequent sections.

3.4.1 Upgrading of existing DIVAC systems (SH/SC to SC/SCC) with DIVATRONIC modules (see Section 5.3)

Described in the following are the necessary steps for retrofitting or upgrading a DIVAC system to the fully featured version beginning with the following initial situations:

- System with baseplate, separator and condenser already present: upgrading with installation accessories.
Corresponds to the DIVAC SH system, see Section 3.4.1.
- System with baseplate, separator, condenser, control unit, support post and DIVATRONIC DT 1 controller already present: upgrading with installation accessories.
Corresponds to the DIVAC SC system, see Section 3.4.2.

3.4.1.1 System with already present Baseplate, Separator and Condenser (SH System)

For this please also refer to Fig. 1.

- Required tools:
 - 1 hex. socket screw key 4 mm and 5 mm
- Shut down the pump and disconnect from the mains (see Section 3.6).

Warning You must pull the mains plug.



- Both DIVATRONIC DT 1 controllers, including venting valves, the pump relief valve as well as the two vacuum valves are supplied already installed on the support post.
- Attach the control unit to the left hand side of the baseplate.
 - Insert the two tightening nuts which have been fitted to the control unit into the slot pointing to the side by pushing the control unit.
 - Tighten by tightening the two hex. socket screws at the base of the control unit.
- Installation of the support post together with DIVATRONIC DT 1 controllers and valves
 - Insert the support post (attachment section) into the slot pointing up on the baseplate (for alignment see Fig. 5).

- Tighten the support post by tightening the hex. socket screw located in the slot at the support post.

- For hose connections refer to Fig. 14.

Caution Use only such a hose material which is able to resist the kind of media used.

- Electrical wiring and connections.
 - Controller DIVATRONIC DT 1 with control unit:
Connect DIVATRONIC DT 1 controller connection “SOL.2” to the connection “V.IN. 1” or “V.IN. 2” on the control unit using the supplied cables (see Fig. 15).
 - Plug the mains plug of the DIVATRONIC DT 1 controller into the corresponding socket on the control unit (see Fig. 10 or 15).
 - Vacuum valves with control unit:
Insert the two plugs of the vacuum valves into the sockets “SOL. 1” and “SOL. 2” on the control unit (see Fig. 15).
 - Pump relief valve with control unit:
Insert the plug on the cable for the pump relief valve into socket “PRV” on the control unit (see Fig. 15).
 - Pump with control unit:
Insert the mains connector of the pump into the marked mains socket with protective ground conductor on the control unit (see also Fig. 10).

Caution For proper operation of the entire system it is necessary that the mains connection of the pump be provided through this socket with protective ground conductor.

- Connection of the control unit to the mains:
Insert the mains plug with protective ground conductor on the mains cable of the control unit into a properly installed mains socket with connected protective ground conductor.

3.4.1.2 System with already present Baseplate, Separator, Condenser, Control Unit, Support Post and one DIVATRONIC DT 1 controller (SC Systems)

For this refer to Fig. 1.

- Required tools:
 - 1 hex. socket wrench 4 mm

Key to Fig. 15

- 1 Pump relief valve
- 2 Connection "SOL. 2" on DIVATRONIC DT 1 controller 1
- 3 Connection "SOL. 2" on DIVATRONIC DT 1 controller 2
- 4 Connection "PRV" on the control unit
- 5 Connection "V.IN. 2" on the control unit
- 6 Connection "V.IN. 1" on the control unit
- 7 Connection "SOL. 2" on the control unit
- 8 Connection "SOL. 1" on the control unit
- 9 Mains socket with protective ground for controller 2
- 10 Mains socket with protective ground for controller 1
- 11 Mains connection

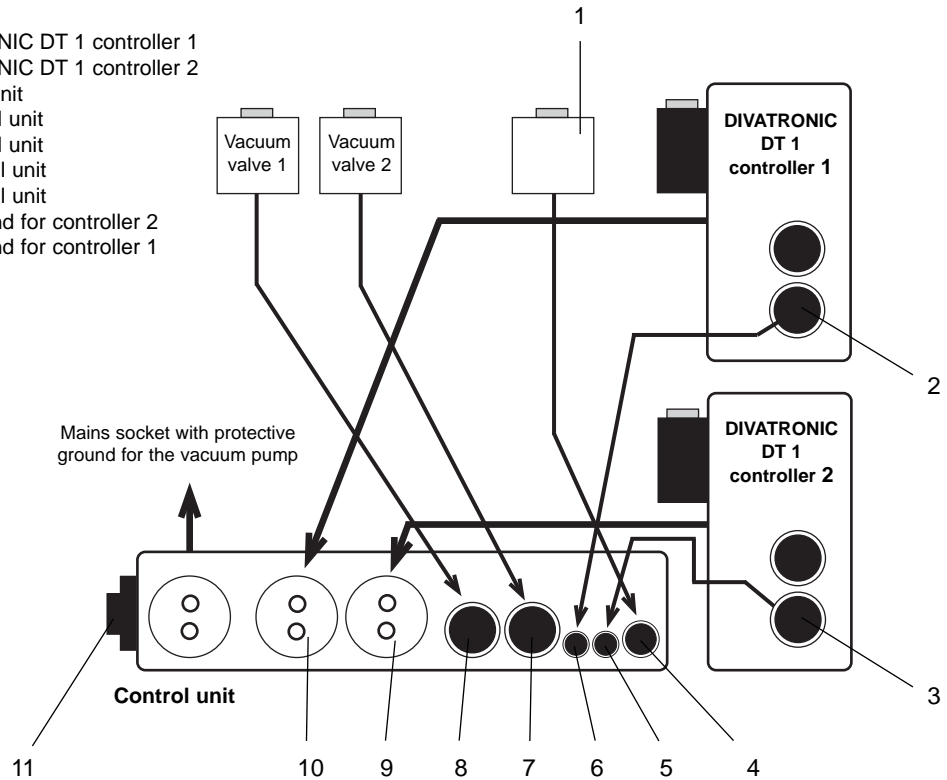

Fig. 15 Electrical connection on the DIVAC system SCC 0.6 L - 1.2 L - 2.2 L (EURO Version)

Disassembly steps

- Shut down the pump and disconnect the control unit from the mains (see Section 3.6).

Warning You must pull the mains plug.



- Disconnect all plugs from their sockets or mains sockets on the control unit.
- Disconnect all hose connections at the pump relief valve as well as on the venting valve of the DIVATRONIC DT 1 controller.
- Remove the DIVATRONIC DT 1 controller from the support post after loosening the clamped connection.
- Remove the cross bar from the support post after loosening the clamped connection.
- Remove the support post from the baseplate:
 - Release the clamped connection by loosening the hex. socket screw at the support post.

– Pull the support post out of the slot in the baseplate.

- The second DIVATRONIC DT 1 controller with venting valve is supplied already fitted to the new support post (410 mm long).
- Attach the controller which has previously been used to the support post too: insert into the slot provided for this purpose on the DIVATRONIC DT 1 controller (its tightening nut) and fix in place by tightening the hex. socket screw.
- Insert the support post (its attachment section) into the slot on the baseplate at the side which faces up.
- Fix the support post in place by tightening the hex. socket screw at the support post in the slot.
- Attach the cross bar to the support post again.
- Insert the holder for the solenoid valve (including the solenoid valve itself) into the cross slot on the support post and fix it in place through the clamped connection.
- Provide the hose connections according to Fig. 14.

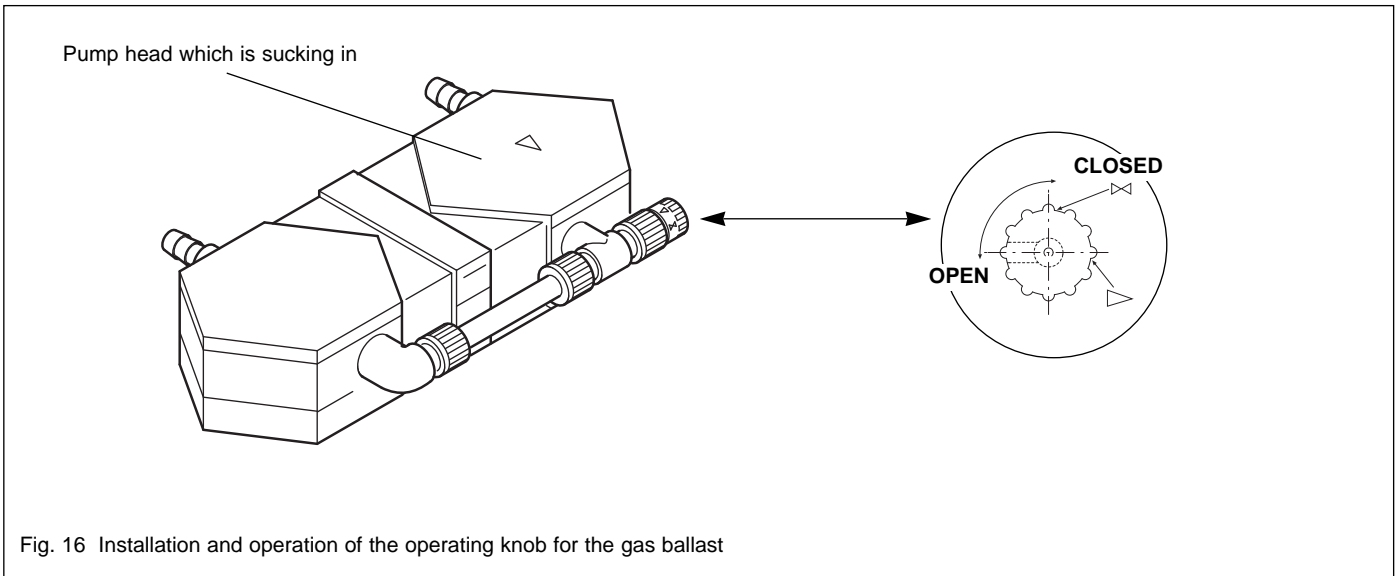

Fig. 16 Installation and operation of the operating knob for the gas ballast

Caution Use only such a hose material which is able to resist the kind of media used.

- Provide the electrical connections (as described in Section 3.4.1).

The following applies equally to Sections 3.4.1 and 3.4.2:

Before starting the pump system check the following:

- all clamped connections for tightness,
- all hose connections as to whether they are connected at the right places,
- all wiring as to whether it is connected at the right places.

3.5 Gas Ballast Option

The gas which flows in through the gas ballast valve reduces the vapour partial pressure within the compression chamber of the DIVAC, thereby preventing any condensation of vapours during the compression process.

Caution When the gas ballast valve is open, the attainable ultimate pressure will be somewhat worse.

Installation

Warning Pull the mains plug.



- Disconnect the hoses at the pneumatic pump inlets and outlets.
- Remove the pump from the baseplate.
- Open the circuit between the pump heads (see Fig. 16).
- Unscrew the connection piece at the intaking pumping head (see Fig. 16).
- Screw the gas ballast device into the pump head.
(The gas ballast connection piece has been taped with Teflon tape, since only Teflon will seal on Teflon).
- Attach the circuit between the two pump heads again.

3.6 Shut Down

- Clean the vessels.
- Purge the fully installed hose system on the pump with air for about 5 minutes at full throughput.
- Pull the mains plug.

3.7 Troubleshooting

3.7.1 System without DIVATRONIC DT 1 Controller (SH/SR Systems)

- A sufficient vacuum is not attained.

Possible causes:

- Leaky hoses connections.
- Condensate in the pump head (separate the source of the condensate from the pump, run the drying mode according to Section 3.3.7).
- Diaphragm and /or valve disk are worn out. The valve disk or the diaphragm will have to be exchanged (see Section 3.8).
- After having exchanged diaphragms, valve discs and or gaskets: see description of Section 3.8.
- Pump has been switched on, but it is not running, mains switch does also not come on.

Possible causes:

- The pump has not been connected to the mains.
- No mains voltage is present.
- Fuse for the pump has blown.

Warning Leave troubleshooting to suitably trained personnel.



Disconnect the pump from the mains by pulling the mains plug.



- After loosening the marked lid under the pump, the fuse will be accessible.
- Pump has been switched on, but it is not running, mains switch is on.

Possible cause:

- The overtemperature switch on the pump has responded because of overheating (pull the mains plug, let the pump cool down, determine the cause for overheating and remove the cause).

3.7.2 System with one DIVATRONIC DT 1 Controller (SC Systems)

- A sufficient vacuum is not attained.

Possible causes: same as for systems without DIVATRONIC DT 1 controller (see Section 3.7.1).

Possible additional causes:

Solid objects in the relief valve of the pump.

- DIVATRONIC DT 1 controller has been switched on and set to the “Regulation mode”, setpoint is not attained, pump is not running, light in the mains switch of the pump is not on.

Possible causes:

- Pump has not been switched on,
- Incorrect wiring,
- Fuse of the pump has blown (see Section 3.7.1, system without DIVATRONIC DT 1 controller).
- DIVATRONIC DT 1 controller has been switched on and set to the “Regulation mode”, setpoint is not attained, pump is not running. Light in the mains switch is on.

Possible cause:

- The overtemperature switch on the pump has responded because of overheating.
(Pull the mains plug of the pump, let the pump cool down, determine the cause for overheating and remove the cause).
- DIVATRONIC DT 1 controller has been switched on, nothing is displayed on the LCD display.

Possible causes:

- Mains switch of the DIVATRONIC DT 1 controller has been plugged into the mains socket on the pump’s control unit.
- Fuse in the DIVATRONIC DT 1 controller has blown.
(This fuse is located above the On/Off switch of the DIVATRONIC DT 1 controller)
- Fuse in the control unit has blown.
(These fuses are located on the face side of the control unit directly under the mains connection).
- DIVATRONIC DT 1 controller indicates unrealistic values.

Possible causes:

- Factory alignment for the pressure as changed (contact Leybold).
- Sensor is faulty (contact Leybold).

3.7.3 System with two DIVATRONIC DT 1 Controllers (SCC Systems)

- See system with one DIVATRONIC DT 1 controller (Section 3.7.2)
- System is not working although one DIVATRONIC DT 1 controller (or both DIVATRONIC DT 1 controllers) has (have) been set to the "Regulation mode".

Possible cause:

- The signal cables of the two DIVATRONIC DT 1 controllers or the vacuum valves have not been connected properly (the connectors between controller 1 and 2 or those for the vacuum valves 1 and 2 have been interchanged).

3.8 Exchanging Diaphragms and Valves Plates

The diaphragms should always be exchanged on both pump heads together. When exchanging the diaphragms, the valve plates of the pump should also be exchanged. If both pump heads are not maintained in the same way, it can not be guaranteed that the pump will meet its nominal specifications also after having completed the maintenance work.

Required tools / materials:

- Spare parts kit (see Section 6).
- Phillips screwdriver No. 2.

Preparations

- Shut the pump down, (see Section 3.6), and separate the pump from the mains (pull the mains plug).
- Disconnect the hoses at the pneumatic pump inlets and outlets.
- Remove the pump from the baseplate, if required.

Disassemble the pump head

- Open the circuit between the pump heads.
- Loosen the 6 outer screws at each of the two pump heads.
- Carefully remove the pump heads.

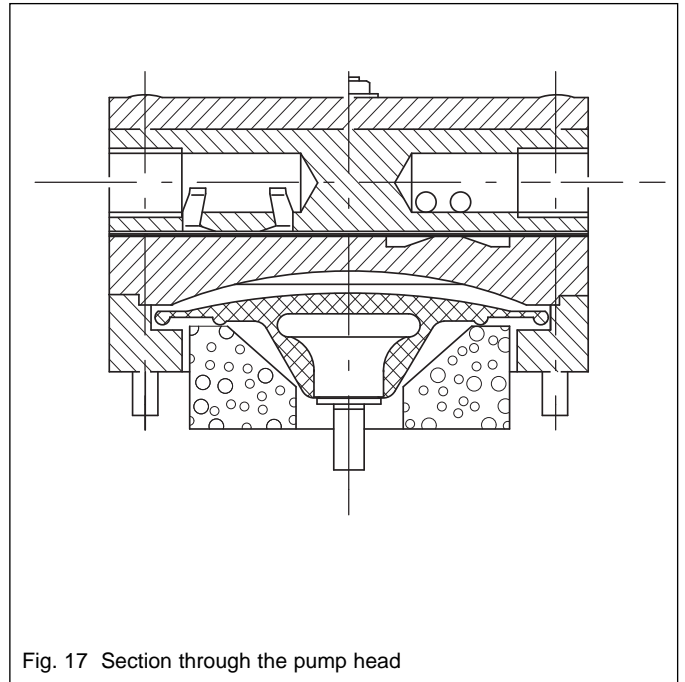

Fig. 17 Section through the pump head

Exchanging the diaphragm

- Because access to the diaphragms is easier, take hold of the diaphragm and carefully turn it out in the anti-clockwise direction (thread).
- Place the same number of washers found on the diaphragm thread onto the thread of the new diaphragm.
- If required, bring the second diaphragm to its upper return point by pressing on to the connecting rod which is now accessible.
- Unscrew the second diaphragm as described above.
- Screw the new diaphragm in.
- Press the lip of the diaphragm down around the circumference.

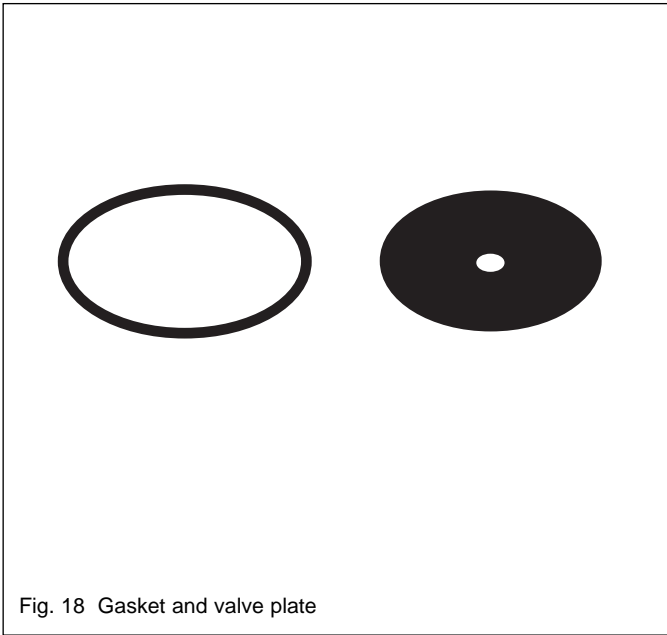

Fig. 18 Gasket and valve plate

Exchanging the valve plate

- Loosen the single screw at the center of the lid for the pump head.
- Carefully remove this lid; gasket and valve plate are now accessible.
- Remove the old gasket and the old valve plate.
- Carefully fit the new gasket and the new valve plate.
- Properly fit the lid for the pump head.
- Tighten the screw at the center of the lid until the head of the screw is flush with the lid. Then tighten the screw further by half a turn.

Installing the pump head

- Fit the pump heads to the pump housing (observe the guide pin) and tighten crosswise using moderate force.
- Install the circuit between the pump heads.
- Place the pump on the baseplate (if present).
- Provide the hose connections again.

If, after having exchanged the diaphragm, the desired vacuum is not attained:

- Check whether or not the necessary number of washers have been fitted on to the thread of the diaphragm.
- Check the connection between the pump heads and the hose connections for the existence of any leaks.
- Possibly the screws of one or both pump heads have not been sufficiently tightened (tighten further crosswise).

Caution Tighten the bolts for lids of the heads (19/3) until encountering some resistance and then tighten by a further 1/2 turn. Do not bolt down tightly!

4 Technical Data

		DIVAC 0.6 L	DIVAC 1.2 L	DIVAC 2.2 L
Pumping speed, max.	m ³ · h ⁻¹	0.6	1.2	2.2
Ultimate pressure	mbar	8	8	8
Max. exhaust overpressure	bar	1	1	1
Permissible ambient temperature	°C	+5 to +40	+5 to +40	+5 to +40
Permissible temperature for the pumped gas	°C	+5 to +40	+5 to +40	+5 to +40
Motor power	VA	90	120	200
Protection	IP	44	44	44
Weight	kg	6.9	9.3	12.6
Dimensions (L x W x H)	mm	275 x 141 x 183	310 x 157 x 202	334 x 170 x 221

5 Ordering Information

5.1 DIVAC Pump System

	DIVAC 0.6 L	DIVAC 1.2 L	DIVAC 2.2 L
Diaphragm vacuum pump 230 V, 50 Hz with 2.3 m long mains cord and plug	Cat. No. 135 00	Cat. No. 135 06	Cat.-No.. 135 12
Diaphragm vacuum pump 230 V, 50 Hz Version for Switzerland	Cat. No. 135 04	Cat. No. 135 10	Cat.-No.. 135 16
Diaphragm vacuum pump 240 V, 50 Hz Version for Great Britain	Cat. No. 135 01	Cat. No. 135 07	Cat.-No.. 135 13
Diaphragm vacuum pump 100 V, 50/60 Hz with 2.3 m long mains cord and NEMA plug	Cat. No. 135 02	Cat. No. 135 08	Cat.-No.. 135 14
Diaphragm vacuum pump 115 V, 60 Hz with 2.3 m long mains cord and NEMA plug	Cat. No. 135 03	Cat. No. 135 09	Cat.-No.. 135 15
Spare parts kit consisting of: 2 diaphragms, 4 gaskets, 4 valve plates	Cat. No. 135 23	Cat. No. 135 24	Cat.-No.. 135 25
Components for the modular DIVAC-System:			
Basepanel for system mount	Cat. No. 135 18	Cat. No. 135 18	Cat.-No.. 135 19
Separator	Cat. No. 135 20	Cat. No. 135 20	Cat.-No.. 135 20
High performance condenser	Cat. No. 135 21	Cat. No. 135 21	Cat.-No.. 135 21
Gas ballast valve	Cat. No. 135 26	Cat. No. 135 27	Cat.-No.. 135 27
Vacuum controller DIVATRONIC DT 1 230 V, 50 Hz	Cat. No. 161 17	Cat. No. 161 17	Cat.-No.. 161 17
Vacuum controller DIVATRONIC DT 1 100 - 115 V, 50/60 Hz	Cat. No. 89 617	Cat. No. 89 617	Cat.-No.. 89 617

5.2 Accessories for the Modular DIVAC - System

	Contents	Cat. No.			
		Euro Version 230 V, 50 Hz	GB Version 240 V, 50 Hz	USA/Japan Version 115 V, 60 Hz 100 V, 50/60 Hz	Swiss Version 230 V, 50 Hz
Module SR	Baseplate + system mount Separator, suction side Separator, pressure side Hose connections	135 40	135 40	135 40	135 40
Module SH	Baseplate + system mount Separator, suction side Hose connections High performance condenser	135 50	135 50	135 50	135 50
Module SC	Baseplate + system mount Separator, suction side High performance condenser Vacuum controller DIVATRONIC DT 1 Pump relief valve Control unit (incl. hose)	135 60	135 61	135 62	135 63
Module SCC	Baseplate + system mount Separator, suction side High performance condenser Vacuum controller DIVATRONIC DT 1 Pump relief valve Control unit (incl. hose) Double valve block Second vacuum controller DIVATRONIC DT 1 (Incl. hose)	135 70	135 71	135 72	135 73

When ordering the module please also state the Cat. No. of the required pump (see page 23).

Example: The DIVAC system SH 0.6 L consists of the DIVAC module SH (Cat. No. 135 50) and DIVAC pump 0.6 L (Cat. No. 135 00)

5.3 DIVATRONIC Modules

	Contents	Cat. No.			
		Euro Version 230 V, 50 Hz	GB Version 240 V, 50 Hz	USA/Japan Version 115 V, 60 Hz 100 V, 50/60 Hz	Swiss Version 230 V, 50 Hz
DIVATRONIC DT1	Vacuum controller DIVATRONIC DT1 Connecting piece (Tee) with hose nozzle Spare fuse	161 17	–	869 17	–
Module DIVATRONIC A	Vacuum controller DIVATRONIC DT1 Support post Pump valve (24 V) Control unit incl. all cables	135 80	135 81	135 82	135 83
Module DIVATRONIC B	Second vacuum controller DIVATRONIC DT1 Support post Double valve (24 V) incl. all cables	135 85	135 85	135 87	135 85
Module DIVATRONIC A/B	2 vacuum controllers DIVATRONIC DT1 Support post Pump and double valve (24 V) Control unit incl. all cables	135 90	135 91	135 92	135 93

6 Spare Parts

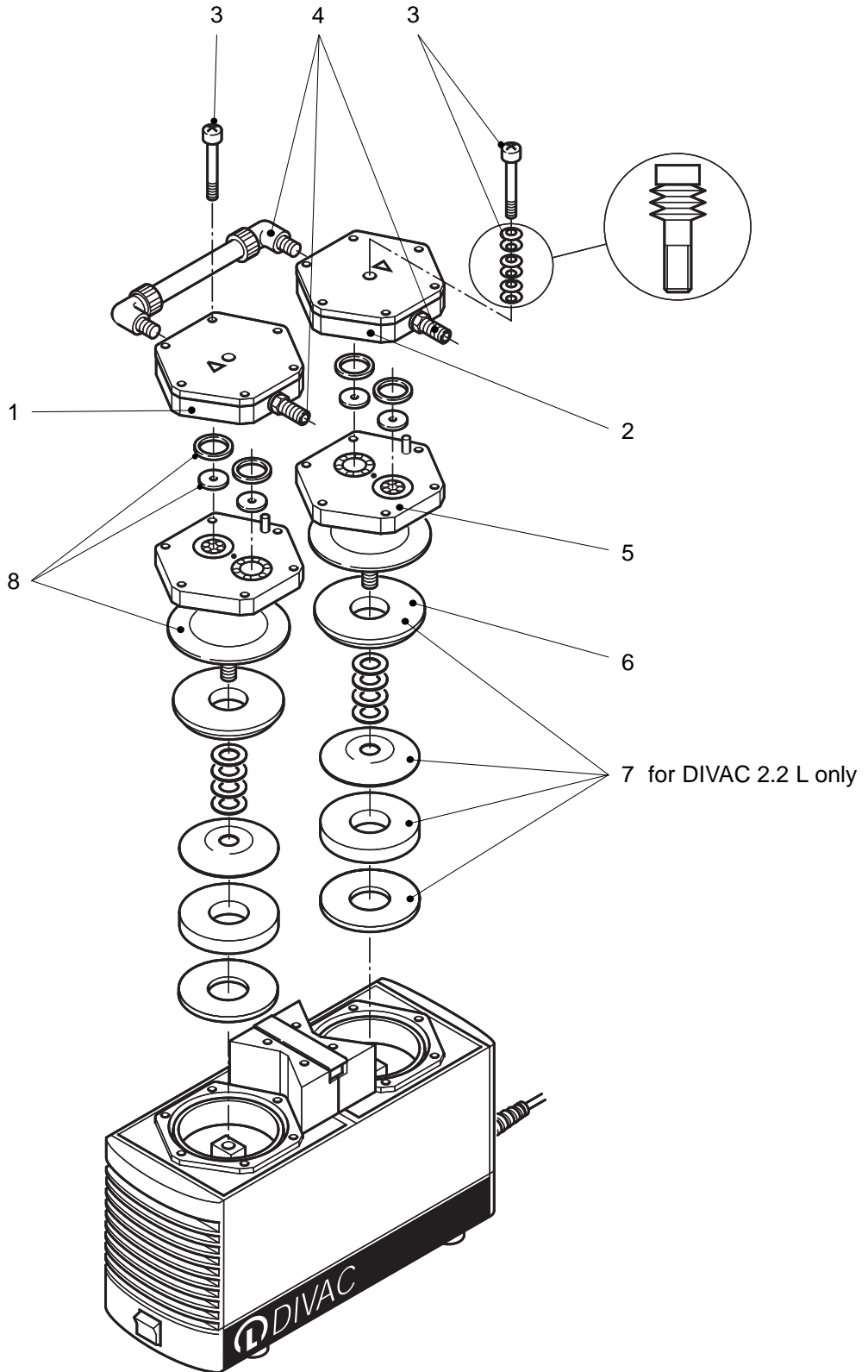

Fig. 19 Spare parts

Item	Quantity			Designation	Remarks/ material	Ref. No.
	DIVAC 0.6 L	DIVAC 1.2 L	DIVAC 2.2 L			
1	1			Lid A - DIVAC 0.6 L	PTFE	200 65 009
1		1		Lid A - DIVAC 1.2 L	PTFE	200 65 011
1			1	Lid A - DIVAC 2.2 L	PTFE	200 65 013
2	1			Lid B - DIVAC 0.6 L	PTFE	200 65 010
2		1		Lid B - DIVAC 1.2 L	PTFE	200 65 012
2			1	Lid B - DIVAC 2.2 L	PTFE	200 65 014
3	1			Set of bolts for one head	includes spring washers	200 65 018
3		1		Set of bolts for one head	includes spring washers	200 65 019
3			1	Set of bolts for one head	includes spring washers	200 65 020
4	1			Set of hose nozzles DIVAC 0.6 L		200 65 005
4		1		Set of hose nozzles DIVAC 1.2 L		200 65 006
4			1	Set of hose nozzles DIVAC 2.2 L		200 65 007
4a	1			Hose nipple	NPT 1/8"	200 65 025
4a		1	1	Hose nipple	NPT 1/4"	200 65 026
5	1			Intermediate panel	PTFE	200 65 015
5		1		Intermediate panel	PTFE	200 65 016
5			1	Intermediate panel	PTFE	200 65 017
6	1	1		Silencing kit DIVAC 0.6 L + 1.2 L	included with item 8	---
7			1	Silencing kit DIVAC 2.2 L		200 65 001
8	1			Maintenance kit - DIVAC 0.6 L *)		135 23*)
8		1		Maintenance kit - DIVAC 1.2 L *)		135 24*)
8			1	Maintenance kit - DIVAC 2.2 L *)		135 25*)
				*) contains all parts required for maintenance of the pump head. (2 diaphragms, 4 gaskets, 4 valve plates and the silencing parts for the DIVAC 0.6 L and DIVAC 1.2 L)		
---	1	1	1	Norprene hose	1 m	200 65 002
---	1	1	1	Vacuum valve, single	see Fig. 1, item 16	200 65 003
---	1	1	1	Vacuum valve, double	see Fig. 1, item 15	200 65 004

Declaration of Contamination of Vacuum Equipment and Components

The repair and/or service of vacuum equipment and components will only be carried out if a correctly completed declaration has been submitted. Non-completion will result in delay. The manufacturer could refuse to accept any equipment without a declaration.

This declaration can only be completed and signed by authorized and qualified staff.

<p>1. Description of Vacuum Equipment and Components</p> <ul style="list-style-type: none"> - Equipment type/model: _____ - Code No.: _____ - Serial No.: _____ - Invoice No.: _____ - Delivery date: _____ 	<p>2. Reason for Return</p> <p>_____</p> <p>_____</p> <p>_____</p> <p>_____</p>
<p>3. Condition of the Vacuum Equipment and Components</p> <ul style="list-style-type: none"> - Has the equipment been used? yes <input type="checkbox"/> no <input type="checkbox"/> - What type of pump oil/liquid was used? _____ - Is the equipment free from potentially harmful substances? yes <input type="checkbox"/> (go to Section 5) no <input type="checkbox"/> (go to Section 4) 	<p>4. Process related Contamination of Vacuum Equipment and Components:</p> <ul style="list-style-type: none"> - toxic yes <input type="checkbox"/> no <input type="checkbox"/> - corrosive yes <input type="checkbox"/> no <input type="checkbox"/> - explosive*) yes <input type="checkbox"/> no <input type="checkbox"/> - biological hazard*) yes <input type="checkbox"/> no <input type="checkbox"/> - radioactive*) yes <input type="checkbox"/> no <input type="checkbox"/> - other harmful substances yes <input type="checkbox"/> no <input type="checkbox"/>

*) Vacuum equipment and components which have been contaminated by biological explosive or radioactive substances, will not accepted without written evidence of decontamination!

Please list all substances, gases and by-products which may have come into contact with the equipment:

Trade name Product name Manufacturer	Chemical name (or Symbol)	Dangerous material class	Measures if spillage	First aid in case of human contact
1.				
2.				
3.				
4.				
5.				

5. Legally Binding Declaration

I hereby declare that the information supplied on this form is complete and accurate. The despatch of the contaminated vacuum equipment and components will be in accordance with the appropriate regulations covering Packaging, Transportation and Labelling of Dangerous Substances.

Name of organisation or company: _____

Address: _____ Post code: _____

Tel.: _____

Fax: _____ Telex: _____

Name: _____

Job title: _____

Date: _____ Company stamp: _____

Legally binding signature: _____

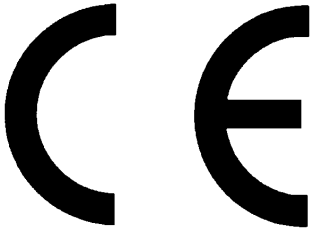

EEC Declaration of Conformity

We - LEYBOLD Vacuum GmbH - herewith declare that the products defined below meet the basic requirements regarding safety and health of the relevant EC directives by design, type and versions which are brought into circulation by us.

In case of any product changes made without our approval, this declaration will be void.

Designation of the products: Diaphragm pump

Types: DIVAC 0.6 L; 1.2 L; 2.2 L

Cat. Nos.:

135 00; 135 01; 135 02; 135 03; 135 04;

135 06; 135 07; 135 08; 135 09; 135 10;

135 12; 135 13; 135 14; 135 15; 135 16;

135 40; 135 50;

135 60; 135 61; 135 62; 135 63;

135 70; 135 71; 135 72; 135 73;

135 80; 135 81; 135 82; 135 83;

135 85; 135 87;

135 90; 135 91; 135 92; 135 93

The products conform to the following directives:

- EEC Directive on EMI (89/336/EWG)
- EEC Directive on Low-Voltages (73/23/EWG)

Applied harmonised standards:

- EN 292 Part 1 and Part 2
- EN 294
- EN 61 010 Part 1
- EN 50 081 Part 1
- EN 50 082 Part 1
- EN 50 014
- EN 60 555 Part 2 and 3

We reserve the right to alter the design or any data given in these Operating Instructions. The illustrations are not binding.