

Vacuum Solutions

Application Support

Service

GA 01.703/5.02

Chemtech Scientific provides access to this content as a courtesy.
We do not own the content contained in this document.
All rights and credit go directly to its rightful owners.
www.chemtechsci.com
Call us at: 484-424-9415



EcoDry - M with FC Motor

Oil-free Vacuum Pumps

EcoDry M 15

130 005

EcoDry M 20

130 015

EcoDry M 30

130 033

Operating Instructions

Contents

	Important Safety Considerations	.4
1	Introduction	.6
1.1	Principles of Operation	.6
1.1.1	Stages of Compression	.6
1.1.2	Sealing	.6
1.1.3	Lubrication	.6
1.1.4	Friction and Cooling	.6
1.1.5	Eliminating Hydrocarbon Contamination	.6
1.2	Specifications	.7
2	Installation and Operation	.11
2.1	Unpacking the Pump	.11
2.1.1	Receiving Conditions	.11
2.1.2	Unpacking the Pump	.11
2.1.3	Inspecting the Pump	.11
2.1.4	Supplied Equipment	.12
2.2	Installation	.12
2.2.1	Suggested Installation Procedure	.12
2.2.2	Connection to the System	.13
2.3	Electrical Connection	.13
2.3.1	Technical Data for the Frequency Converter	.13
2.3.2	Opening the Junction Box	.14
2.3.3	Mains Connection	.14
2.3.4	Connecting the Control Cables	.14
2.4	Switching On	.17
2.4.1	Operating Panel and LC Display	.17
2.4.2	Menu Structure	.17
3	Operating the Pump	.23
3.1	Error Messages during Start-up or Operation	.23
3.2	Error Matrix / Frequency Converter	.23
3.3	RS 485 Parameter List	.24
4	Application Notes	.26
4.1	Areas of Application	.26
4.2	EcoDry M Pumps for Backing of High-Vacuum Pumps	.26
4.2.1	Turbopumps and Wide Range Turbo Pumps	.26
4.3	Condensable Vapours & Liquids	.26
4.4	Use on Wet Processes	.26
5	Repair, Maintenance and Service	.27
5.1	Repair	.27
5.2	Maintenance	.27
5.3	Service	.27
6	Troubleshooting	.28
	EC Declaration of Conformity	.29

We reserve the right to modify the design and the specified data. The illustrations are not binding.



These Operating Instructions contain important information which needs to be observed during placement, installation and operation. For this reason these Operating Instructions must be read under all circumstances by the personnel doing the installation work and the operators responsible before beginning with any work on the EcoDry.

Figures

The references to figures, e.g. (1/2) consist of the Fig. No. and the Item No. in that order.

Warning This indicates procedures and operations which must be strictly observed to prevent hazard to persons.



Caution This indicates procedures and operations which must be strictly observed to prevent damage to, or destruction of the pump.

Hazards which may arise when not observing the safety information provided

When not observing the safety information provided, persons may suffer injury and property may be damaged, and this is not covered by our warranty in any way.

Leybold-Service

When returning a pump back to Leybold, please state whether the pump is free of substances presenting a health hazard or if it is contaminated.

If the pump is contaminated please also state the type of hazard. Pumps received without a Declaration of Contamination must be returned by Leybold back to the sender.

IMPORTANT SAFETY CONSIDERATIONS

The Leybold EcoDry M, oil-free vacuum pump is designed for safe and efficient operation when used properly and in accordance with this manual. It is the responsibility of the user to carefully read and strictly observe all safety precautions described in this section and throughout the manual. This product must be operated and maintained by trained personnel only. Consult local, state, and national agencies regarding specific requirements and regulations. Address any further safety, operation and/or maintenance questions to your nearest Leybold Vacuum office.

Warning Failure to observe the following precautions could result in serious personal injury:



- Before beginning with any maintenance or service work on the EcoDry M, disconnect the pump from all power supplies.



- Do not operate the pump with any of the covers removed. Serious injury may result.
- If exhaust gases must be collected or contained, do not allow the exhaust line to become pressurised.
- Make sure that the gas flow from the exhaust port is not blocked or restricted in any way.



- The standard version of the EcoDry M is not suited for operation in explosion hazard areas. Contact us before planning to use the pump under such circumstances.

- The EcoDry M is not suited for pumping of:
 - combustible and explosive gases or vapours
 - radioactive and toxic substances
 - pyrophorous substances.

- Avoid exposing any part of the human body to the vacuum.
- Never operate the EcoDry without having connected an intake line or a blank flange first.
- The location at which the EcoDry M (including its accessories) is operated should be such that angles over 10° from the vertical are avoided.
- The location of the EcoDry M should be such that all controls are easily accessible.



- Under certain ambient conditions the EcoDry M may attain a temperature of over 80 °C (176 °F). There then exists the danger of receiving burns. Note the symbols on the pump pointing to the hazards, and in the case of a hot pump wear the required protective clothing.

- The noise level produced by the EcoDry M running at 750 rpm without gas ballast is ≤ 59 dB(A) with silencer or connected exhaust line. Make sure that suitable protection measures are taken to protect the hearing.

Warning



- Before operating the EcoDry M with atmospheric gas ballast check first compatibility with the pumped media so as to avoid hazardous conditions during operation right from the start.

- Before commissioning the EcoDry M, make sure that the media which are to be pumped are compatible with each other so as to avoid hazardous situations. All relevant safety standards and regulations must be observed.

- It is recommended to always operate the EcoDry M with a suitable exhaust line which is properly connected. It must slope down and away from the pump.
- When moving the EcoDry M always use the allowed means.
A lifting eye is provided as standard on the pump.

Caution *Failure to observe the following precautions could result in damage to the pump:*

- Do **not** allow the ingestion of small objects (screws, nuts, washers, pieces of wire, etc.) through the inlet port. Always use the screen which is supplied with every pump.
- Do **not** use the pump for applications that produce abrasive or adhesive powders or condensable vapours that can leave adhesive or high viscosity deposits. Please contact Leybold Sales or Service to select a suitable separator. Also please contact Leybold Sales or Service when planning to pump vapours other than water vapour.
- This pump is suited for pumping water vapour within the specified water vapour tolerance limits.
- Avoid vapours that can condense into liquids upon compression inside the pump, if these substances exceed the vapour tolerance of the pump (> 25 mbar for water vapour).
- Before pumping vapours, the EcoDry M should have attained its operating temperature, and the gas ballast should be set to position I - III (position 0 = closed, position 3 = max. water vapour tolerance, 25 mbar).
The pump will have attained its operating temperature about 30 minutes after starting the pump. During this time the pump should be separated from the process, by a valve in the intake line, for example.
- Be sure that the lines (exhaust and intake lines) and other vacuum connections are clean and free of oil. This applies in particular if oil sealed pumps were used before. The conditions must be checked before commissioning, and in the case of deviations you should contact your nearest Leybold Service office.
- In the case of wet processes we recommend the installation of liquid separators upstream and downstream of the pump as well as the use of the gas ballast.
- The exhaust line should be laid so that it slopes down and away from the pump so as to prevent condensate from backstreaming into the pump.
- In order to prevent the transfer of vibrations from the EcoDry M to other parts of the system we recommend the use of corrugated hoses or compensators on both the intake and the exhaust sides. In case you need any further information please get in touch with Leybold.
- Operate the EcoDry M only in the orientations detailed in the dimensional drawings (see page 8). For the purpose of reducing the transfer of vibrations to the building we also recommend the use of vibration absorbers (see accessories for the EcoDry M).

Note *This information will help the operator to obtain the best performance from the equipment:*

- Normal amounts of humidity within the range of the pump's vapour tolerance will not significantly affect pump performance when the gas ballast is active.
- With the pump switched off, the pressure in the pump will rise very slowly to the level of the **exhaust pressure (normally atmospheric pressure)**. The EcoDry M is not equipped with any vacuum protection means. Thus you must install a valve in the intake line which automatically seals off the intake port of the EcoDry M when at standstill.

1 Introduction

EcoDry M pump provides **a clean, absolutely oil-free** means of evacuation. The gas compression stages achieve pressures as low as $5.5 \cdot 10^{-2}$ mbar (for M 15 / M 30) and $8 \cdot 10^{-1}$ mbar (for M 20).

The ECO drive frequency converter integrated in the motor of the pump has been specially developed for Leybold pump applications. By changing the output frequency of the frequency converter, the motor speed of the pump is changed depending on the performance demanded of the pump.

Motor and frequency converter form a single unit which in comparison with drive units not controlled in such a manner does not impose any additional restrictions as to the installation location.

Please note the recommendations as to the applications provided in these Operating Instructions.

1.1 Principles of Operation

1.1.1 Stages of Compression

The EcoDry M is equipped with three (M 15 / M 30) or two (M 20) compression stages which are formed by three or four pistons respectively.

The gas to be pumped reaches the compression space of the cylinder by means of slots formed in the walls of the cylinders. These slots are uncovered by the piston at bottom dead center and then covered again as the piston ascends. The gas is compressed while the piston ascends and exits the compression chamber through large valves.

1.1.2 Sealing

At initially high pressures, gases may leak past the piston from the compression chamber and into the drive-unit housing (called "blow-by"). However, the EcoDry M drive-unit housing is designed such that blow-by gases are drawn back into the last stages and exhausted.

Moreover, the entire sealing system of the EcoDry M is so designed that a low leak rate in the order of $< 1 \cdot 10^{-4}$ mbar · l · s⁻¹ is attained. The static seals made of Viton and the PTFE radial shaft seals which are lubricated with a grease which is free of hydrocarbons and which are highly media compatible, reliably prevent the exchange of gas between the EcoDry M and the surrounding atmosphere.

To avoid internal leakage reducing the pump performance, the cylinder and piston are manufactured to very close tolerances, leaving almost no gap between them. Additional sealing collars are provided towards the drive-unit housing. Towards the outside the chamber of the shaft is sealed off by a radial shaft seal.

1.1.3 Lubrication

The pistons are covered with a low-friction material. The low friction coefficient of the PTFE lets it serve as a bearing and seal without additional liquid lubricants.

Moreover, all rolling bearings are lubricated with a grease which is free of hydrocarbons and they are separated by a dry seal from the vacuum chamber within the pump.

1.1.4 Friction and Cooling

Due to the selection of the pump materials, the friction (and therefore the heat generated) is kept very low. No additional cooling is needed in normal applications.

Caution When installing the pump in an enclosure make sure that there is an adequate flow of cooling air.

1.1.5 Eliminating Hydrocarbon Contamination

The risk of contamination by hydrocarbons is a major concern with mechanical oil-sealed pumps because liquid lubricants can stream back into the chamber to be evacuated. The EcoDry M achieves high compression ratios by using dry multiple-stage compression **instead** of oil sealing, and absolutely no liquid lubricants are used in the compression chambers.

1.2 Specifications

		EcoDry M 15	EcoDry M 20	EcoDry M 30
Number of cylinders		3	3	4
Number of pumping stages		3	2	3
Max. pumping speed				
- at 750 rpm	m ³ · h ⁻¹	11	14	19
- at 1000 rpm	m ³ · h ⁻¹	15	18	25
- at 1200 rpm	m ³ · h ⁻¹	16	22	30
Ultimate pressure (absolute) ²⁾		5.5 · 10 ⁻²	8 · 10 ⁻¹	5.5 · 10 ⁻²
- at 1200 min ⁻¹				
Inlet pressure limit				
- at initial evacuation	mbar		1000	
- in continuous operation	mbar		100	
Water vapour tolerance	g · h ⁻¹	290	400	290
- at 1000 rpm		with gas ballast set to "3"	with gas ballast set to "3"	with gas ballast set to "3"
Leak rate (integral)	mbar·l·s ⁻¹	1 · 10 ⁻⁴	1 · 10 ⁻⁴	1 · 10 ⁻⁴
Motor power requirements at inlet pressures < 10 mbar				
- at 750 rpm	W	280	280	330
- at 1000 rpm	W	320	320	380
- at 1200 rpm	W	330	330	433
Motor speed	min ⁻¹		750 / 1000 / 1200	
Motor protection	IP	44	44	44
Noise level at ultimate pressure ¹⁾	dB(A)			
	at 750 rpm	59	59	63
	at 1000 rpm	63	63	67
	at 1200 rpm	66	66	70
Permissible ambient temperature	°C	0 to 50	0 to 50	0 to 50
Connections / inlet port			DN 25 KF or G 3/4"	
Connections / outlet port			DN 25 KF or G 3/4"	
Total weight with motor	kg	47	47	59

¹⁾ without gas ballast, with silencer (accessory) or connected exhaust line.

²⁾ at extradition

1.2.1 Accessories

Silencer	P/N 130 050
Vibration absorbing feet (set = 4 pcs.)	P/N 130 051
Solenoid gas purge kit	P/N 169 50
Vibration absorber kit	P/N 130 052

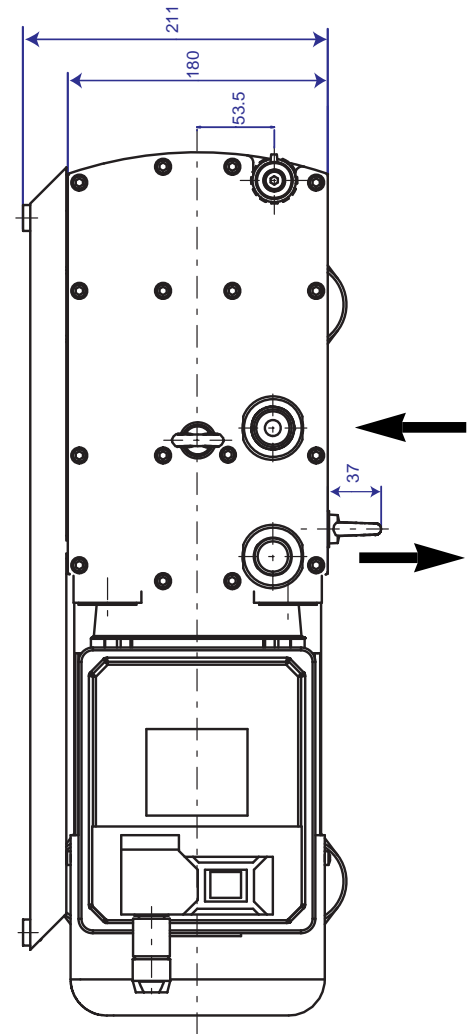
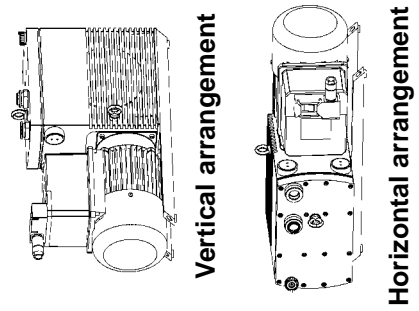
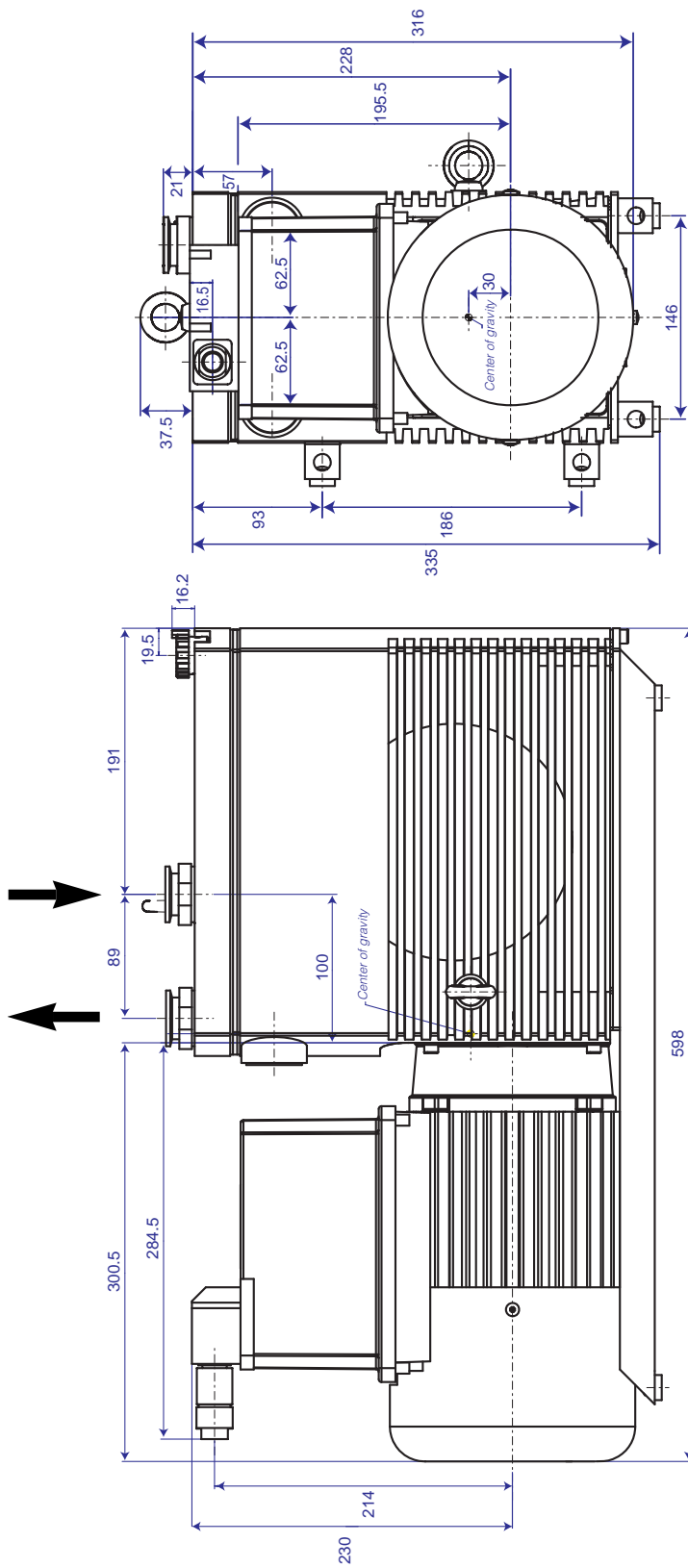

Fig. 1 Dimensional drawing for EcoDry M 15 / 20

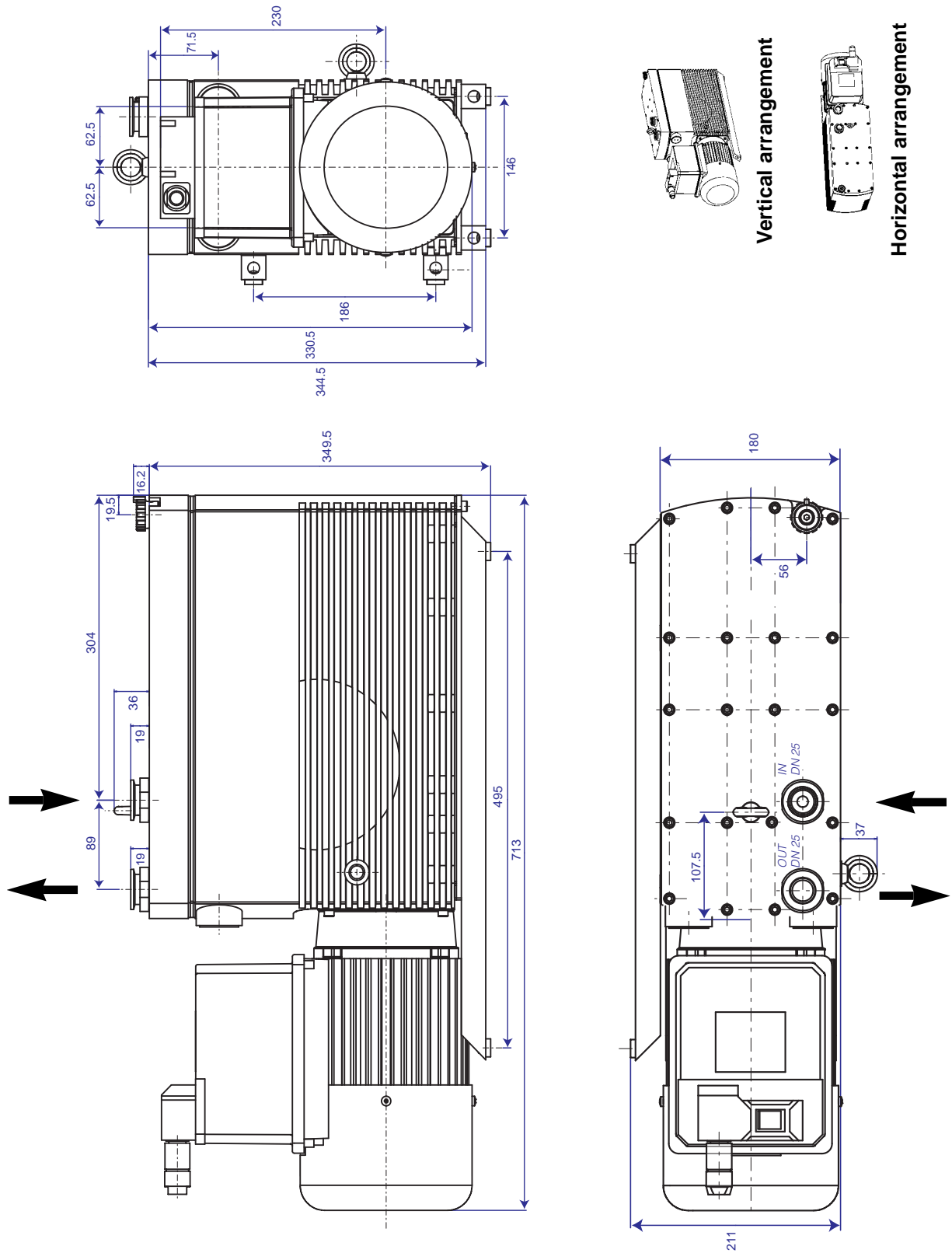
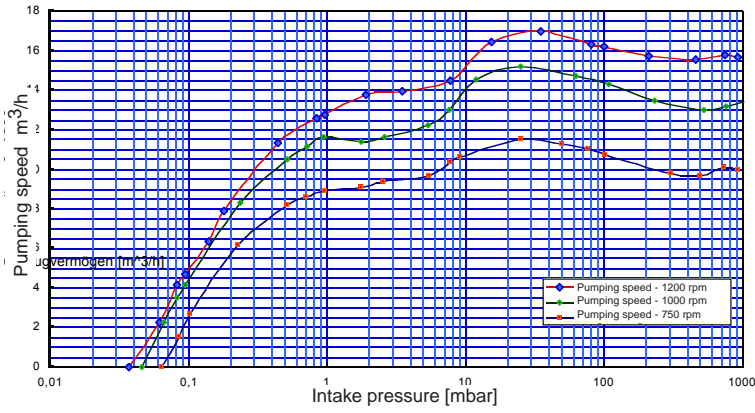
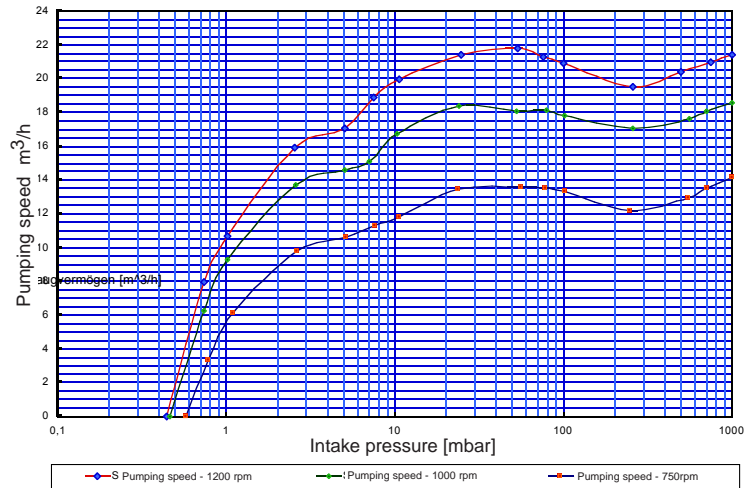

Fig. 1a Dimensional drawing EcoDry M 30

Pumping speed - Ecodyr M15 with world motor
 230 V - 50 Hz - M 15 with silencer, without gas ballast
 Converter pre-set to 750 rpm - 1000 rpm - 1200 rpm



Pumping speed - Ecodyr M20 with world motor
 230 V - 50 Hz - M 20 with silencer, without gas ballast
 Converter pre-set to 750 rpm - 1000 rpm - 1200 rpm



Pumping speed - Ecodyr M30 with world motor
 230 V - 50 Hz - M 30 with silencer, without gas ballast
 Converter pre-set to 750 rpm - 1000 rpm - 1200 rpm

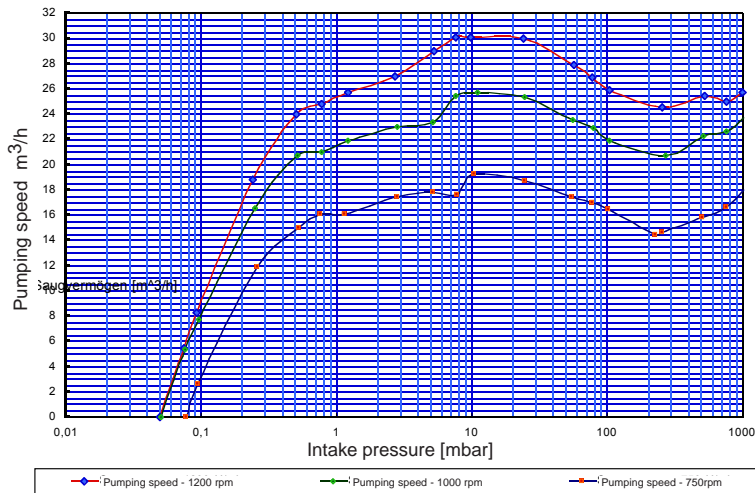

Fig. 2 Pumping speed

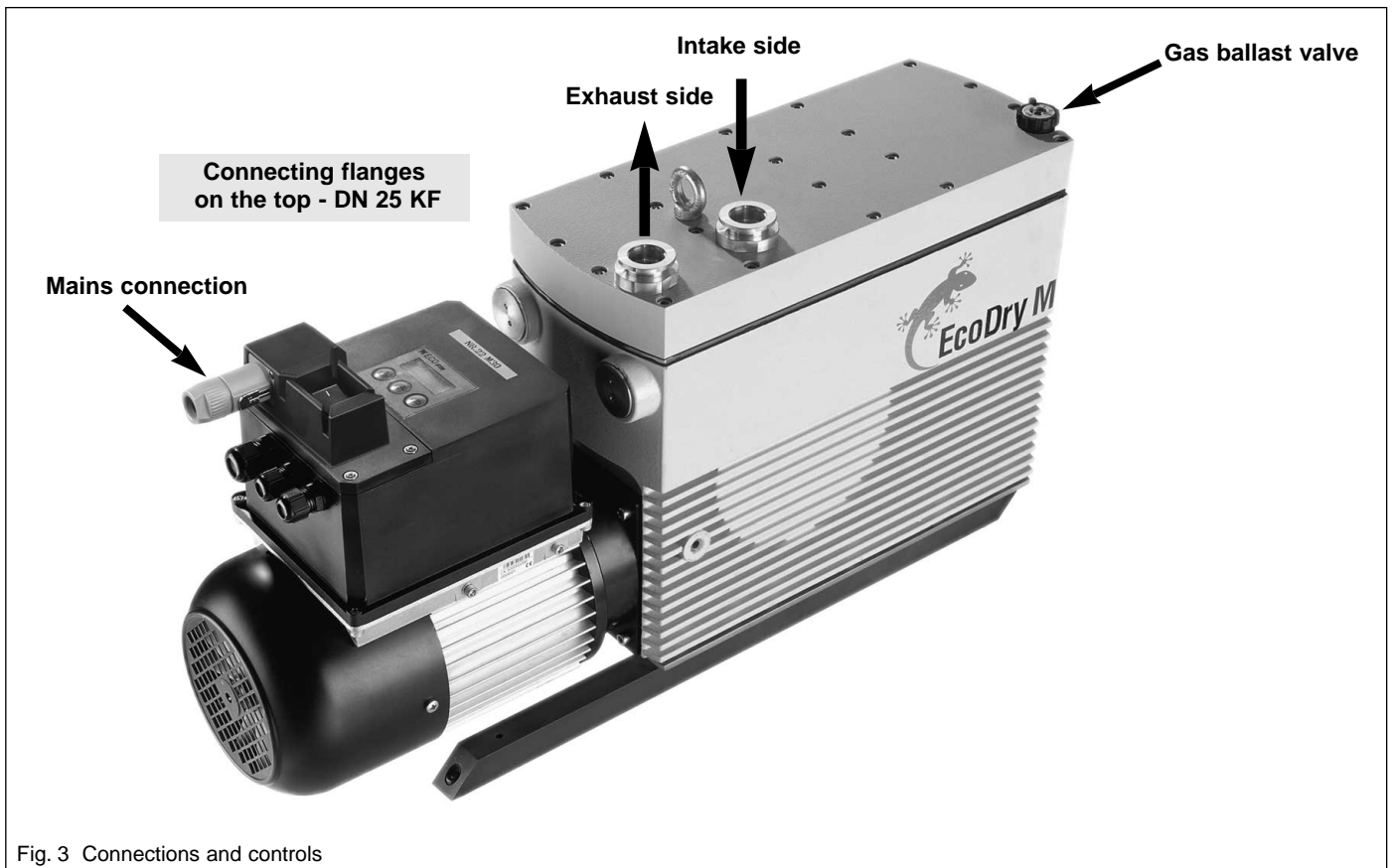

Fig. 3 Connections and controls

2 Installation and Operation

Note The pump complies with NRTL requirements. For this reason the system must not be modified without having consulted LV first. In the case of modifications, the pump will no longer comply with NRTL requirements.

2.1 Unpacking the Pump

Leybold Vacuum inspects each EcoDry M pump before shipping and packs each pump carefully to avoid damage from improper handling.

2.1.1 Receiving Conditions

Inspect shipping crate for external damage.

If damaged:

- Refuse the shipment.
- Notify Leybold Vacuum immediately.

2.1.2 Unpacking the Pump

1. Open the top of the shipping crate.
2. Remove any packing materials.
3. The pump is equipped with a lifting eye, and should **only** be lifted with this device.

2.1.3 Inspecting the Pump

Inspect the pump for damage.

If damaged:

- Notify Leybold Vacuum immediately.
- Retain the original shipping and packing materials.
- Wait for return authorisation from Leybold Vacuum.
- Return the pump in the original package via the original shipper.

2.1.4 Supplied Equipment

The EcoDry M is supplied with the following basic items:

- Pump with motor
- Separate dirt collecting screen (dirt trap)
- Operating Instructions
- “Declaration of Contamination” form

The connection ports are sealed off before shipping with sealing caps.

The EcoDry M is supplied with a frequency controlled motor and may be plugged directly into a suitable mains socket.

Country specific plugs for USA and Euro are included with each pump.

2.2 Installation

The EcoDry M pump is installed upright or horizontally on the anti-vibration mounts provided.

Make sure that there is a clearance of at least 100 mm to other components or pumps at every side to allow an adequate air flow for cooling.

The EcoDry M pump is a complete unit. Listed below are several optional accessories that will lead to more efficient operation and prolong the useful life of the pump.

- Dust filter, liquid separator for the inlet
- Vibration absorbers
- Exhaust silencer
- Inert gas connection

2.2.1 Suggested Installation Procedure

Caution The EcoDry M must only be operated in such orientations where the axis of the pump (crankshaft) runs horizontally.

Warning Please accurately observe the following safety information given in these Operating Instructions.



1. Install in an open area with an ambient temperature below 50°C (122 °F). If the pump must be installed in an enclosed area, air-circulating fans may be necessary to ensure adequate cooling.
2. Before connecting the EcoDry M to the intake and exhaust lines please remove the shipping seals on the pump's intake and exhaust flanges. Connect the chamber to be evacuated to the inlet flange of the EcoDry M pump.
3. Use flexible stainless steel bellows in the piping to reduce transmission of vibrations during operation.
4. Make sure pipe lines are adequately supported to reduce stress on joints.
5. Install a vacuum gauge in the inlet line with a vacuum-quality valve upstream of the gauge. This allows the pump to be isolated from the system to monitor its proper performance.
6. Install the stainless steel screen (dirt trap) provided over the inlet port to prevent the ingestion of small objects that can damage the pump. The flow rate may be somewhat reduced by the screen, but the protection it provides will prolong the life of the pump.
7. Make sure that the exhaust port is clean and unobstructed.

Caution Lines (intake and exhaust lines) and other vacuum connections must be clean, especially if previously evacuated by oil-sealed mechanical pumps.

Warning



Make sure that the gas flow at the exhaust port is not blocked or restricted in any way.

If the exhaust gases must be contained or collected, do not allow the exhaust line to become pressurised.

2.2.2 Connection to the System

Please note the safety information given on page 4 and the subsequent pages.

Warning



The pump must only be started up after having fully assembled it.

The exhaust line should be laid so that it slopes down and away from the pump in order to prevent condensed vapours from flowing back into the pump.

During operation, the exhaust side must always be open. Check any valves which may be present in the exhaust line. The max. exhaust backpressure must never exceed 1200 mbar abs.

2.3 Electrical Connection

2.3.1 Technical Data for the Frequency Converter

Type of pump	Piston pump
Motor power	900 W
Nominal current uptake (1~)	7 A (264 V) to 13 A (90 V)
Recommended mains fuse	EUROPE - Earthed plug 10 A USA - NEMA 5-15, 15 A (100V/120 V, also for Japan) Japan - NEMA 6-16, 15 A (200 V) GB - Brit. standard plug, 10 A
Max. wire cross section	2.5 mm ² (with plugged-in mains plug)
Cooling	by motor fan
Altitude	up to 1000 m above sea level without impairing performance
Protection - frequency converter	IP 44
Electrical protection	short circuit and open circuit proof, protected against mains phase failure
Resistance to interference	acc. to EN 61000-6-2
Interference levels generated	acc. to EN 50081-1
Influence on the mains	acc. to EN 61000-3-2

The product complies with the following European directives:

- **EMC Directive 89/336 EEC**
COUNCIL DIRECTIVE of 3 May 1989 on the approximation of the laws of the Member States relating to electromagnetic compatibility.
- **Low Voltage Directive 73/23/EEC**
COUNCIL DIRECTIVE of 19 February 1973 on the harmonization of the laws of Member States relating to electrical equipment designed for use within certain voltage limits.

Warning



When connected to the mains, the ECO drive converter carries dangerous voltages within. During all work on the converter, the mains power must be switched off and the mains plug must be disconnected first. When not observing this, severe injury or even death or damage to property can result.

The electrical connections must only be provided by a trained electrician in accordance with the regulations of the IEC 64 international series of standards.

Note The pump complies with NRTL requirements. For this reason the system must not be modified without having consulted LV first. In the case of modifications, the pump will **no** longer comply with NRTL requirements.

This equipment is not intended for use in living areas or business and trade areas. The equipment has been designed by the manufacturer for use in an industrial environment. Typical installation locations are machine rooms within a building together with other installations within the building. Running of high frequency receivers, mobile phones and aircraft navigation systems in the frequency range from 40 to 75 MHz in the vicinity of the pump will be possible only conditionally. Possibly arising interferences may be circumvented by increasing the distance between the pump and the receiving facility.

2.3.2 Opening the Junction Box

Warning After switching off the mains voltage the capacitors within the unit may remain charged for some time. For this reason wait for about 5 minutes for the capacitors to discharge before accessing the junction box.



After having removed the 4 hex. socket screws, the cover may be removed from the junction box so that the electrical connections will then be accessible (Fig.4).

2.3.3 Mains Connection

It needs to be ensured that the mains is sufficiently rated to provide the voltage and power as specified on the name plate.

2.3.3.1 Mains Connection via Mains Plug

The enclosed country specific plug (for USA and Europe) is provided for connection to the socket on the junction box (see Fig. 4).

2.3.3.2 Mains Connection via the System

A three conductor, class 1 mains cord rated for 60°C/75°C must be used. For the allowable cross sections see Chapter 2.4.1.

The cable feedthrough for the mains cord is shown in Fig. 4. Use a screwdriver to tighten the terminal screws to a torque of 1.5 Nm max.

The ECO drive converter is suited for operation off mains with 1~ 90 - 264 V, 50 or 60 Hz. Terminals for L, N and PE are available for connecting to the mains (see Fig. 4).

Caution The max cross section for the conductors is 2.5 mm².

- L** - Connection for the live conductor
- N** - Connection for the neutral conductor
- PE** - Connection for the ground conductor

2.3.4 Connecting the Control Cables

Caution Control cables and mains cables must run and be laid separately.

The location of the terminal strip to which the control cables are connected is shown in Fig. 4. Use a screwdriver to tighten the screws of the terminal strips making sure that a torque of 0.4 Nm is not exceeded.

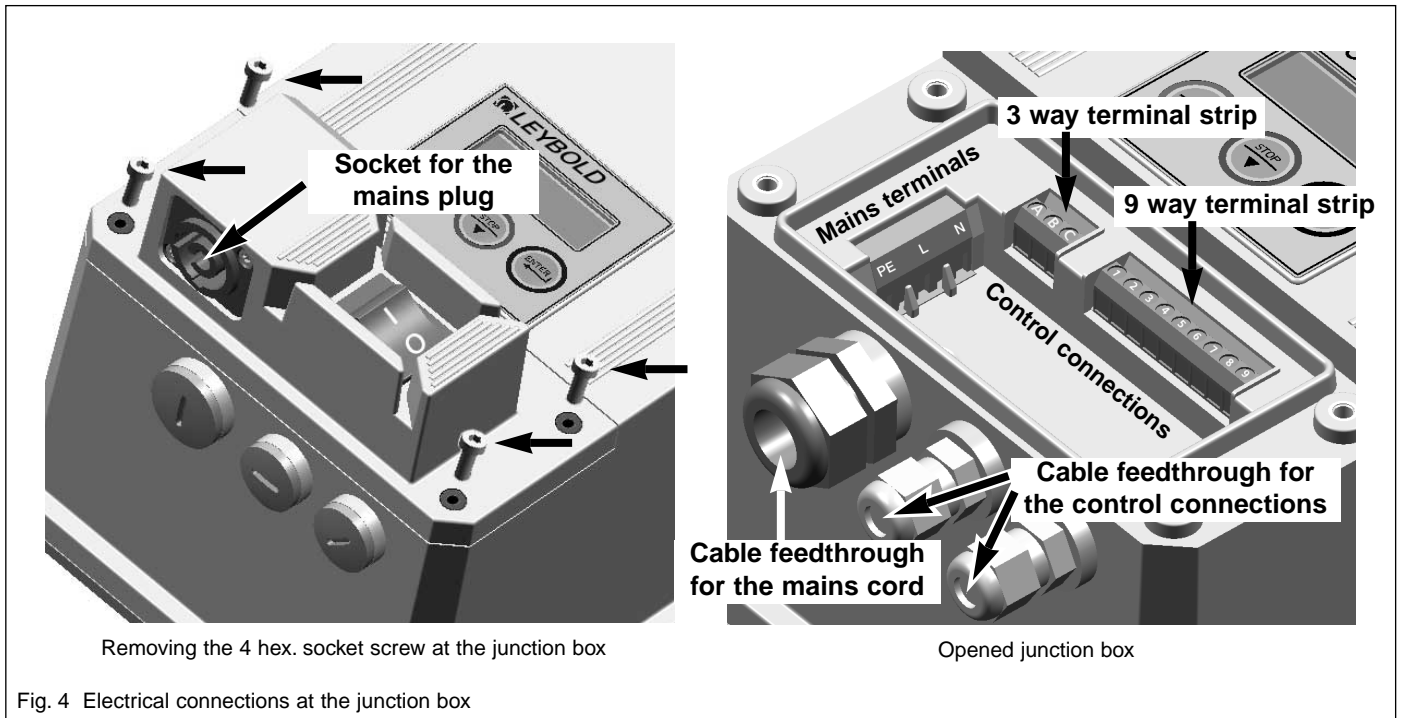

Terminal assignment for 9 way terminal strip (see Fig. 4)

Terminal	Signal	Remark
1	+ 24 V / 50 mA	- Power supply RS 485
2	Digital 1	- Level low: Stop pump - Level high: Enable start
3	Analog out 0...10 V / 10 mA	- Sensing of actual speed
4 / 5 4 = A 5 = B	RS 485 line A/B	- Remote control mode (see also list of parameters)
6	Digital 2	- Currently not used
7	Analog IN 0...10 V; 2...10 V; 0...20 mA or 4...20 mA	- Speed control via controller or sensors
8	+ 10 V / 10 mA	- Power supply for connecting an external potentiometer
9	Ground	

Terminal assignment for 3 way terminal strip (see Fig. 4)

Terminal	Signal	Remark
A / B / C	Relay output 230 V / 1 A (resistive load)	- Changeover relay, indicating the presence of a collective fault in the final shutdown mode. - B = main contact - A = normally closed contact - C = normally open contact

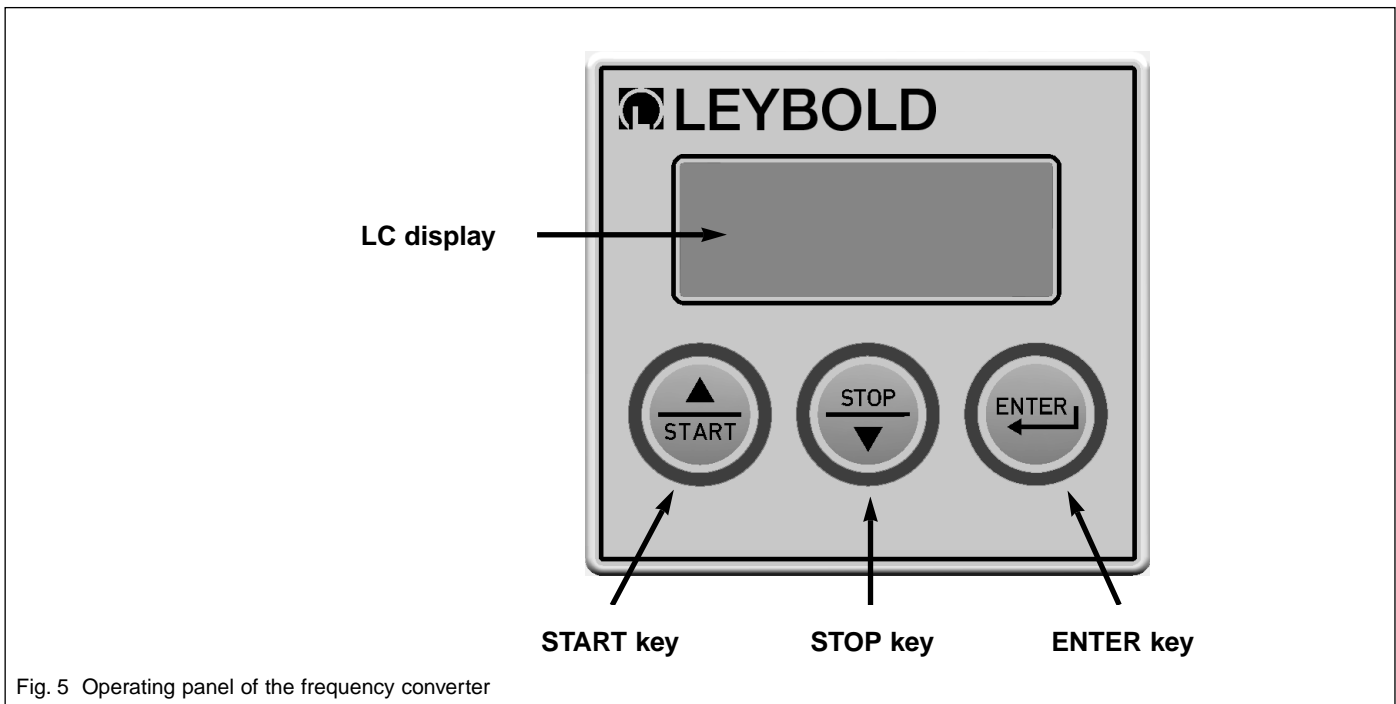
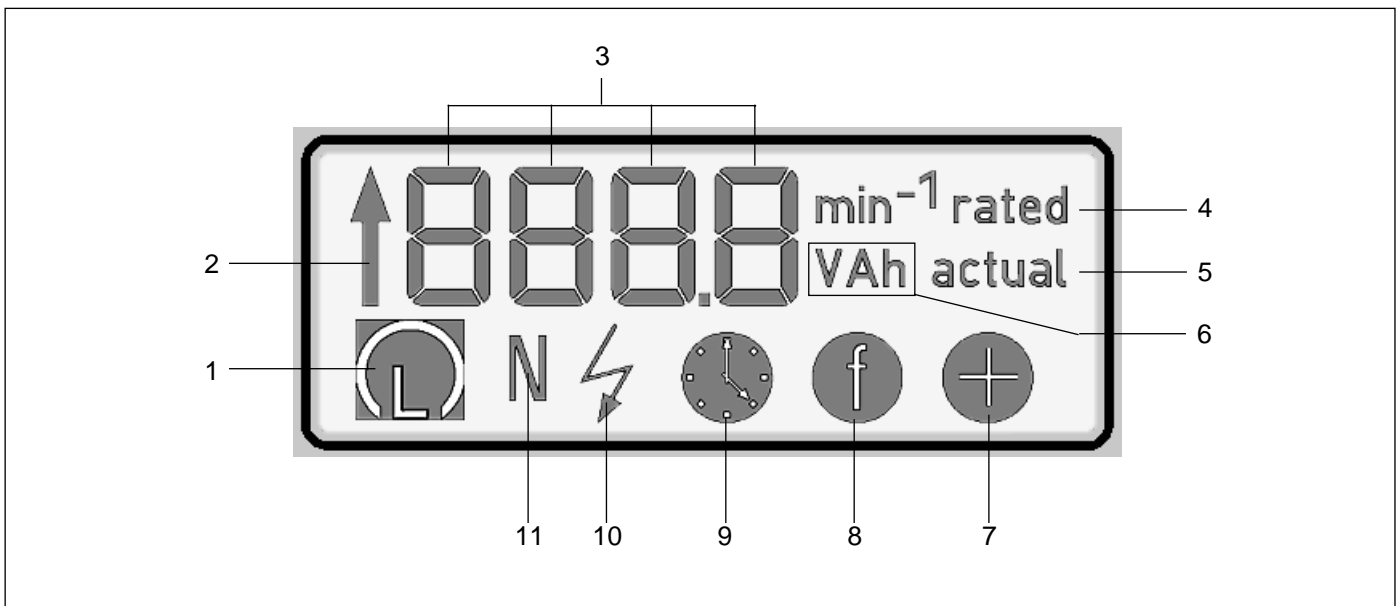

Fig. 5 Operating panel of the frequency converter



Key to Fig. 6

- 1 Ready / control via serial protocol
- 2 Accelerating
- 3 4 x 7 segment display
- 4 Setpoint speed
- 5 Actual speed
- 6 Volt, amps, hours
- 7 Overspeed
- 8 Frequency select
- 9 Operating hours
- 10 Failure
- 11 Normal operation

Fig. 6 Display of the operating panel

2.4 Switching On

2.4.1 Operating Panel and LC Display

Depending on the currently selected menu, different functions are assigned to the keys of the operating panel (Fig. 5).



2.4.2 Menu Structure

Main menu	Start and operating menu
Submenu 1:	Speed setting
Submenu 2:	Voltage and current display
Submenu 3:	Operating hours display
Special menu:	Error code display

2.4.2.1 Start and Operating Menu

As soon as the pump is connected to the mains power, the start and operating menu is invoked automatically.

Function of the keys

Start motor of the pump (internal query) P0204 = Software version P1 = EcoDry M 15; M 20; M 30	
Stop motor of the pump	
No used	

Display



2.4.2.2 Display Setpoint Menu

Keep the "Start" key depressed and use the "Enter" key to scroll through the individual menus.



Function of the keys

Select operating mode "S"

"S" = Switch mode

Fixed speeds:

- "0" U/min
- "750" U/min
- "1000" U/min
- "1200" U/min



Select operating mode "A1"

(select analog voltage operating mode "A1" = analog entry)

Confirm operating mode



Display

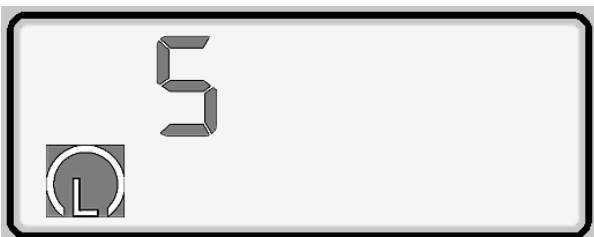

With key



for "A1"

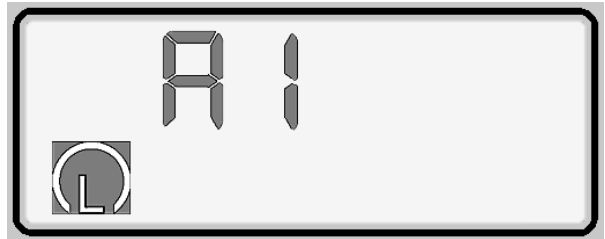

continue with



Select with



or



"0" : 0...10 V

"1" : 2...10 V

"2" : 0...20 mA

"3" : 4...20 mA

then



press



2.4.2.3 Speed Setting (Submenu 1)

The setpoint menu is selected by operating the "Start" key and the "Enter" key **simultaneously**.

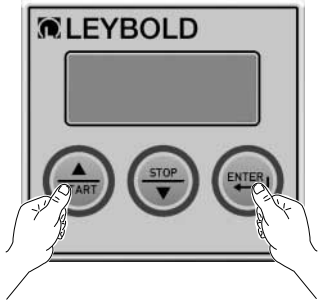

Function of the keys

Increase setpoint speed



Decrease setpoint speed



Accept entry



Display



Changing the setpoint speed

Keep the "Start" key depressed and confirm by pressing the "ENTER" key. **Display S = factory default**

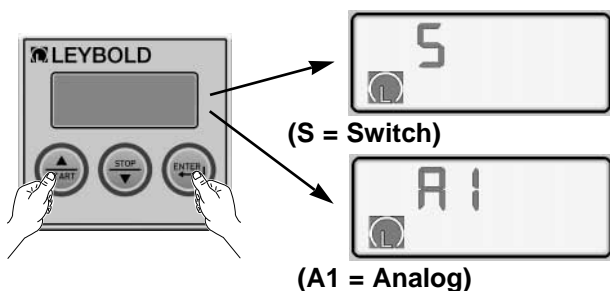

Keep the "START" key depressed again and confirm by pressing "ENTER".

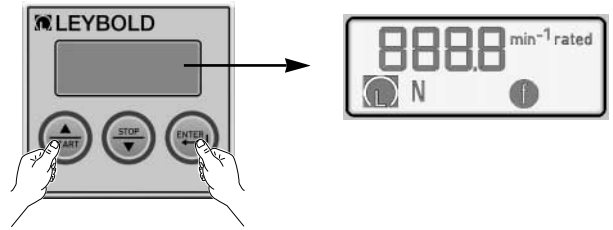

With the "START" key or the "STOP" key change the speed and then confirm by pressing the "ENTER" key.

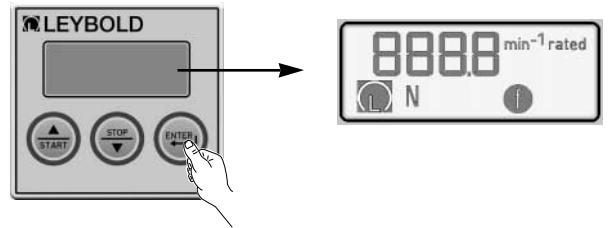
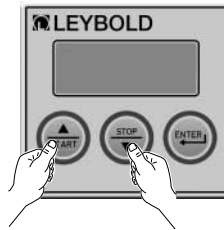

The speed will now change to the entered value.

2.4.2.4 Voltage / Current Display (Submenu 2)

Keep the "START" key depressed and confirm by pressing the "ENTER" key three times.

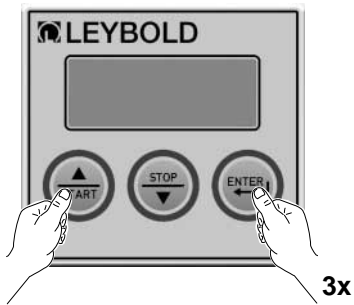

Function of the keys

Toggle between voltage and current readout



Toggle between voltage and current readout



Display

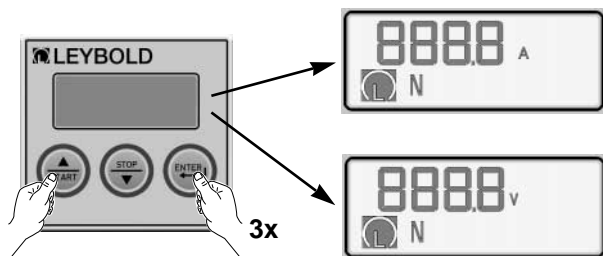

Back to main menu:



2.4.2.5 Operating Hours (Submenu 3)

Keep the "START" key depressed and confirm by pressing the "ENTER" key four times.

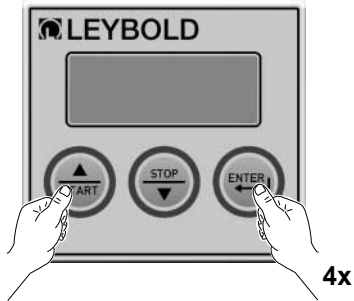

Function of the keys

For adjusting the speed-specific number of operating hours

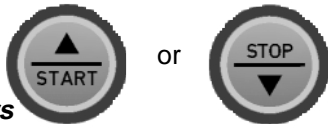

To read the number of operating hours



Back to main menu

Press START and ENTER simultaneously



Display

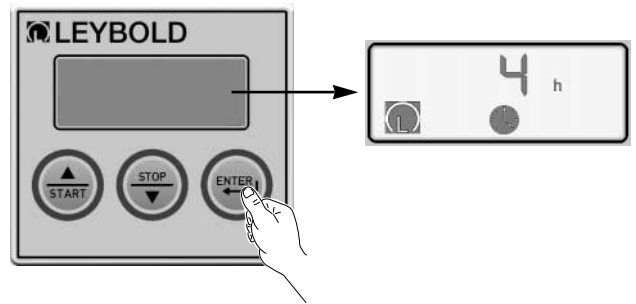

Back to speed select

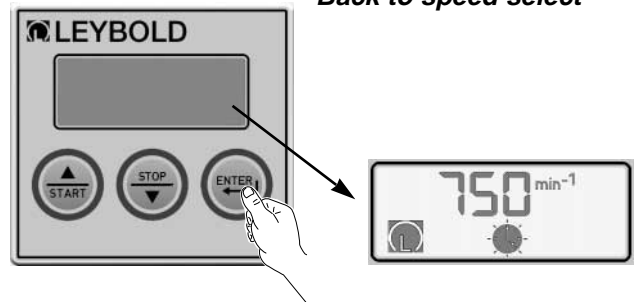

Change speed:

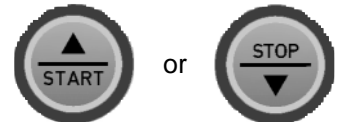

Confirm with:



The desired number of operating hours can be read off (for example:)



Back to main menu

Press START and ENTER simultaneously

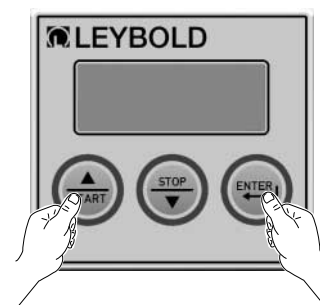

2.4.2.6 Error code Display (Special Menu)

This menu can not (!) be selected manually. This menu will be displayed in the case of a fault.

Not used



Not used



Not used

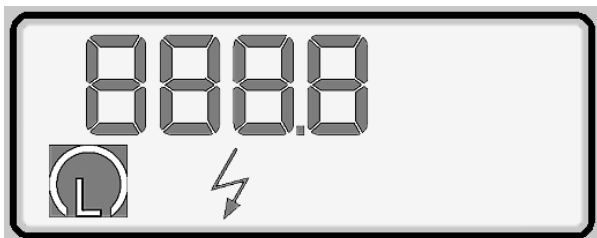

3 Operating the Pump

After having put the cover back on to the junction box, the ECO drive may be started.

3.1 Error Messages during Start-up or Operation

If the ECO drive converter reverts to the failure status because of operating conditions which are not allowed, the drive unit will shut down immediately. The unit starts up automatically in accordance with Chapter 3.2 Error Matrix/Frequency Converter.

The fault cause is indicated on the display through one of the error codes given in the following table.

To restart the pump press all three keys (START, STOP and ENTER) simultaneously. If the error code remains, then the unit must be disconnected from the mains.

Error code	BIT	Description
E001	0	Short circuit affecting current inverter
E002	1	Overvoltage in intermediate circuit
E004	2	Mains voltage is too low
E008	3	Overtemperature current inverter
E010	4	Overtemperature affecting the motor
E020	5	Offset affecting the current sensor Out of range
E040	6	Overtemperature within the converter
E080	7	Overcurrent
E100	8	I ² *t sensing
E200	9	Motor PTC defective
E400	10	Overtemperature
E800	11	Short circuit affecting PFC

The error codes are displayed using hexadecimal notation.

In rare cases also combinations of errors may occur. In such a case the hexadecimal sum will be displayed, for example:

E003 = E001 and E002
 E00A = E002 and E008
 E007 = E001 and E002 and E004
 E0A0 = E020 and E080

3.2 Error Matrix / Frequency Converter

Error	Restart (in 24 h)	Waiting time [s]	Remark
Tripping of current inverter	5	1800	
Overvoltage	∞	2	As soon as the mains voltage regains its normal level for 2 s, the pump will then restart
Undervoltage	∞	2	As soon as the mains voltage regains its normal level for 2 s, the pump will then restart
Overtemperature current inverter	5	300	Long waiting time for cooldown
Overtemperature motor	5	300	Long waiting time for cooldown
Current sensor	0	0	Converter hardware is defective (fatal error)
Overtemperature Inside chamber	5	300	Long waiting time for cooldown
Overcurrent current inverter	5	1800	
I ² *t sensing	5	300	Classic motor protection function
Motor PTC	0	0	Hardware is defective (fatal error)
Overtemperature PFC	5	1800	Long waiting time for cooldown
Tripping of PFC	25	2	

3.3 RS 485 Parameter List

PKE Nos. 0-26 are process data which can be read through the parameter channel of the USS protocol.

PKE Nos. 64-83 are data from the EEPROM.

PKE No.	Designation	EEPROM	R/W address	Resolution	Description / Solution
0	Status/Cmd		R		Read command
1	Converter type		R		10.000=M15; 10001=M30; 10002=TI25B; 10003=Trivac D25B
2	Software version		R		Software version
3	Current speed		R	1 U/min	Actual speed
4	Mains voltage		R	0.1 V	Mains voltage
5	Mains current		R	0.1 V	Mains current
6	Mains power		R	0.1 W	Mains power
7	Motor temperature		R	binary	Only statement OK or not OK
8	Write to EEPROM		W		No function, converter will only confirm the command
10	Switchover BIKOM		W		Switchover to BIKOM mode
11	Converter temperature		R	1° C	Temp. sensor on DSP board
12	Actual speed		R	1 U/min	Actual speed
13	Interm. circuit voltage		R	0.1 V	Interm. circuit voltage
14	Motor current		R	0.1 A	Motor current
15	PFC temperature		R	1° C	PFC temperature
16	Current inverter temp.		R	1° C	Current inverter temp.
17	$I^2 t$ sum		R	100%/32767	$I^2 t$ sum
18	f_min_lcd		R		Min. frequency
19	f_max_lcd		R		Max. frequency
20	Status digital inputs		R	binary	Status digital inputs
21	Analog out		R	10 V/32767	Analog output
22	Read memory		R		Reads RAM memory of the DSP via the BIKOM pointer table
23	Pump type		R		0=Trivac D25B; 1=M15; 2=M30 3=TI16B
24	Setpoint speed		R/W	1 U/min	Setpoint speed
25	Analog 1		R	10 V/32767	Presentation in Q 15, i.e. from 0...32767 = 0...10 V
26	Analog 2		R	10 V/32767	As above, but negative voltages in two's complement
64	ee_ara_set	0x30	R/W		Defines the parameter set
65	ee_hour	0x32	R		Total operating hours
66	ee_power_on	0x33	R		Power on counter
67	ee_kwh	0x34, 0x35	R		Converted electrical work
68	ee_hour_l	0x36	R		Low speed operating hours
69	ee_hour_m	0x37	R		Medium speed operating hours
70	ee_hour_h	0x38	R		High speed operating hours
71	ee_pm_trip	0x40	R		Error counter current inverter trip
72	ee_ueberspg	0x41	R		Error counter overvoltage
73	ee_unterspg	0x42	R		Error counter undervoltage
74	ee_pm_temp	0x43	R		Error counter current inverter overtemperature

PKE No.	Designation	EEPROM	R/W address	Resolution	Description Solution
75	ee_motor_temp	0x44	R		Error counter motor overtemperature
76	ee_offset	0x45	R		Error counter current offset
77	ee_innen_temp	0x46	R		Error counter internal temperature
78	ee_ueberstrom	0x47	R		Error counter motor overcurrent
79	ee_i2t	0x48	R		Error counter $I^2 \cdot t$ sum
80	ee_motor_ptc	0x49	R		Error counter motor PTC
81	ee_pfc_temp	0x4a	R		Error counter PFC temperature
82	ee_pfc_trip	0x4b	R		Error counter PFC trip
83	ee_error_stack	0x50...0x5f	R		Ring memory, index from 0...15
137	USS Adresse	37	R		USS address

4 Application Notes

Warning



Please also note the information provided on potential hazards given on pages 4, 5 and the subsequent pages.

4.1 Areas of Application

The EcoDry M is ideal for applications that require the achievement of pressures as low as $5.5 \cdot 10^{-2}$ mbar (2 Pa, 15 mTorr) (M 15/M 30) without the risk of contamination from liquid lubricants. The pump may be operated intermittently as needed, or continuously. Owing to its freedom from hydrocarbons and no compromise in performance, the EcoDry M replaces single-stage oil-sealed rotary pumps in many applications.

Caution

Do **not** use the pump for applications that produce abrasive or adhesive substances or condensable vapours that can leave adhesive or high viscosity deposits. Also the formation of thicker deposits should be avoided since these too may form adhesive or high viscosity deposits.

4.2 EcoDry M Pumps for Backing of High-Vacuum Pumps

4.2.1 Turbopumps and Wide Range Turbo Pumps

For reliable operation of wide range turbomolecular pumps which require a max permissible backing pressure of > 1 mbar.

The design of the pump permits the EcoDry M to be operated in connection with classic and wide range turbomolecular pumps.

4.3 Condensable Vapours & Liquids

Caution

The EcoDry M pump is **not** suited for prolonged pumping of condensable vapours above the specified water vapour tolerance. Pumping of liquids is to be avoided and will damage the pump.

- Normal amounts of water vapour in atmospheric air will not affect pump performance.

4.4 Use on Wet Processes

Caution

Do not allow direct ingestion of liquids into the pump.

Note the vapour tolerance levels which apply to this pump. In case of any questions in this matter do not hesitate to get in touch with Leybold Vacuum.

Generally the following applies:

- The lines connected to the pump should be so rated that no liquids can suddenly enter the pump.
- The chambers should only contain liquids having a low vapour pressure.
- Note the safety information provided in these Operating Instructions.

5 Repair, Maintenance and Service

5.1 Repair

The user must not repair the equipment himself. In the event of a failure the equipment must be replaced and sent to the service center equipped for repairing this equipment.

Warning



When connected to the mains, the ECO drive converter carries dangerous voltages within.

The converter must only be replaced by qualified technicians.



Before opening the junction box make absolutely sure that the mains power has been switched off.

Before separating any electrical connections check these first to determine that there is no longer a voltage present.

Not observing these instructions can result in severe injury or even death.

5.2 Maintenance

Since no operating means other than electric power are required for operation of the EcoDry M, any maintenance regarding operating agents and consumption is **not** required.

Leybold Vacuum recommends to have the sealing collars replaced once per year (further information upon request).

When returning equipment to our Service please fill in **completely** the "Declaration of Contamination" form.

Caution

If no such declaration is available to the Service, any processing will not be possible and the pump will possibly be returned to the sender.

Warning



The EcoDry M must be packaged in such a way that the pump can not be damaged during shipping and so that no hazardous substances may escape from the package.

5.3 Service

Regular Maintenance

ECO drive converters will normally not require any maintenance. Even so you should regularly check the following:

- if sufficient ventilation for the converter is ensured (the air is discharged radially and axially at the motor's fan),
- if the cables at the PG fittings are guided and held properly.

6 Troubleshooting

Fault	Possible cause	Remedy	Repair
Pump does not start up.	Faulty wiring. Motor defective. Pump has seized.	Check the wiring and repair it. Exchange the motor. Repair the pump.	Electrician Service Service
Pump does not attain its ultimate pressure.	Method of measurement or measuring instrument not suitable. External leak. Degassing through water residues. Process caused strong pollution of the pump. Defective shaft sealing ring. Exhaust pipe dirty. Caution If liners have previously been evacuated by oil-sealed pumps the lines must be cleaned first. Exhaust pressure too high (Pabs =>1200 mbar). Pump's temperature is too low.	Use the right method of measurement or measuring instrument. Measure the pressure directly at the intake port of the pump. Repair the pump. Pump must be run for 30 min in gas ballast position 1, check the process. Disassemble and clean the pump. Change shaft sealing ring. Clean the exhaust pipe and then run the pump in gas ballast position 1. Optimise cross section of the exhaust pipe. Warm up the pump (>1h).	- Service Service Service
Pumping speed of the pump is too low.	Dirt trap in the intake line is clogged. Connection lines too narrow or too long. Exhaust counter-pressure too high. Nom. pumping speed of pump is too low.	Clean the dirt trap. Use sufficiently wide and short intake lines (see application information). Preventive action: Install a dust filter in the intake line Exchange the filter element. Optimise cross section of the exhaust pipe. Check the application.	
After switching the pump off, the pressure in the system increases too fast.	System has a leak. Missing valve for blocking intake (automatic or at pump standstill). Valve at the intake is not closed. Exhaust valve leaky (noisy exhaust system at ult. pressure).	Check the system. Fit a valve that seals off the inlet (see application information). Close the valve for inlet. Repair the pump.	Service
Pump gets hotter than previously observed.	Supply of cooling air is obstructed. Ambient temperature is too high. Process gas is too hot. Exhaust pressure too high.	Install the pump properly (10 cm clearance around the pump). Install the pump properly (<50°C). Change the process, if needed cool down to max. inlet temperature = 50°C. Optimise cross sectional area exhaust pipe.	
The pump is extremely loud.	Faulty bearing. Thick particulate deposits. Silencer defective. High gas throughput with open exhaust port.	Repair the pump. Repair the pump. Repair silencer. Install exhaust line or a silencer.	Service Service

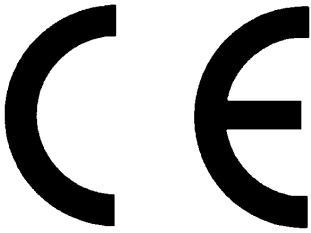

CE Declaration of Conformity

We – LEYBOLD VACUUM GmbH – herewith declare that the products defined below meet the basic requirements regarding safety and health of the relevant EC directives by design, type and the versions which are brought in to circulation by us.

In case of any product changes made without our approval, this declaration will be void.

The products comply with the following guidelines

- EC Directive on Machinery (98/37/EG)
- EC Directive on Low-Voltages (73/23)+(93/68/EWG)
- EC Directive on Electromagnetic Compatibility (89/336/EWG) (91/263/EWG) + (92/31/EWG) + (93/68/EWG)

Product designation: **Oil-free vacuum pump**

Type:	P/N
EcoDry - M 15	130 005
EcoDry - M 20	130 015
EcoDry - M 30	130 033

Applied harmonised standards:

- DIN EN 292 Part 1 11.91
- DIN EN 292 Part 2 06.95
- DIN EN 1012 Part 2 07.96
- DIN EN 60 204 Part 1 11.98
- DIN EN 60 034-1
- DIN EN 60 034-5
- DIN EN 60 034-6
- DIN EN 60 034-9

Applied national and technical specifications:

- DIN 31 001 April 1983

