

Chemtech Scientific provides access to this content as a courtesy.
We do not own the content contained in this document.
All rights and credit go directly to its rightful owners.
www.chemtechsci.com
Call us at: 484-424-9415



Sogevac SV300 B

Single-stage, oil-sealed Rotary Vane Pump

Operating Instructions GA02330_002_02

Part Numbers

960 700 to 960 703

960 706 to 960 708

960 711 to 960 713

960 716 to 960 718



Contents

	Page
Important Safety Information	3
1 Description	4
1.1 Design and function	5
1.2 Standard specification	6
1.3 Technical data	5
1.4 Connection fittings	10
1.5 Accessories	11
1.6 Spare parts	12
1.7 Lubricants	12
1.8 Manipulation and stock	12
2 Operation	12
2.1 Installation	12
2.2 Connection to system	12
2.3 Electrical connections	14
2.4 Start-up	16
2.5 Operation	16
2.6 Shutdown	18
2.7 Ultimate pump pressure	18
3 Maintenance	19
3.1 Maintenance schedule	19
3.2 Checking the oil	20
3.3 Oil change	21
3.4 Cleaning the dirt trap	22
3.5 Checking the anti-suckback valve	22
3.6 Cleaning the gas ballast intake filter	23
3.7 Disassembly of electrical motor	23
3.8 Radiator cleaning	23
4 Troubleshooting Guide	24
EC Declaration of Conformity	
Declaration of contamination	
Spare Parts list	
Sales and Service	

Important Safety Information

It is mandatory that these operating instructions be read and understood prior to the vacuum pump installation and start-up.

The SOGEVAC vacuum pumps have been manufactured according to the newest technical standards and safety regulations. If not installed properly or not used as directed, dangerous situations or damages might occur. Under certain operating conditions, dangerous situations may occur when running the vacuum pump. If this happens, please contact our local office.

Indicate procedures that must be strictly observed to prevent hazards to persons.

Indicate procedures that must be strictly observed to prevent damage to, or destruction of the appliance.

The references to figures, e. g. (2/10) consist of the Fig. No. and the item No. in that order.

We reserve the right to alter the design or any data given in these Operating Instructions.

When working on the pump system, always observe the Operating Instructions. Disconnect the unit from the power supply before starting any work. Take appropriate precautions to ensure that the pump cannot start. If the pump has pumped hazardous gases, it will be absolutely necessary to determine the nature of the hazard involved and take the appropriate safety precautions.

Observe all safety regulations !

Take adequate safety precautions prior to opening the intake or exhaust port.

If you send a pump to Oerlikon Leybold Vacuum, indicate whether the pump is free of substances damaging to health or whether it is contaminated. If it is contaminated also indicate the nature of hazard.

For this you must use the form we have prepared and which will be provided upon request.

A copy of this form, «Declaration of Contamination of Vacuum Instruments and Components» is reproduced at the end of the Operating Instructions.

Please attach this form to the pump, or enclose it with it. This Declaration is required to meet the law and to protect our personnel.

Oerlikon Leybold Vacuum will return any pump received without a "Declaration of Contamination" to the sender's address.

The pump must be packaged in such a way that it will not be damaged during shipping, and so that no harmful substances can escape from the package.

Warning



Notes

Warning



Caution

Figures

Warning



Warning



Description

1 Description

1.1 Design and function

The SOGEVAC SV300 B are single- stage, oil-sealed rotary vane pumps. The anti-suckback valve, gas ballast valve (optional), exhaust filter, oil return circuit and oil cooling oil are integrated functional elements. The pumps are driven by a directly flanged motor.

The rotor mounted eccentrically in the pump cylinder has three vanes which divide the pump chamber into several compartments. The volume of each changes periodically with the rotation of the rotor.

As the rotor rotates, the intake portion of the pumping chamber expands and sucks gas thru the intake port. The gas passes through the dirt trap and the open anti-suckback valve and enters the pump chamber. As the rotor rotates further, the vane separates part of the pump chamber from the intake port. This part of the pump chamber is reduced, and the gas is compressed. At slightly above atmospheric pressure the gas is expelled from the chamber via the exhaust valve.

Oil injected into the pump chamber serves to seal, lubricate and cool the pump. The oil entrained with the compressed gas is coarsely trapped in the oil case by deflection. Then fine filtering occurs in the exhaust filter elements. The proportion of oil in the exhaust gas is thus reduced below the visibility threshold (over 99 % entrapment rate).

Oil trapped in the exhaust filters is returned to the inlet chamber via an oil return transfer. To prevent gas flowing at atmospheric pressure from the oil reservoir into the intake port, the oil return line is controlled by a float valve.

The oil cycle is maintained by the pressure difference existing between the oil case (pressure above or equal to atmospheric pressure) and the intake port (pressure below atmospheric pressure). The ball bearings are greased for 30 000 hours.

A fan running on the pump shaft generates the necessary cooling air. The oil cools down through a radiator.

By opening the gas ballast valve, a controlled amount of air so called «gas ballast» - is admitted into the pump chamber. This gas ballast prevents condensation (up to the limit of water vapor tolerance specified in the Technical Data) when pumping condensable gases or vapors.

There are different types of gas ballast :

- small gas ballast (4 m³/h)
- standard gas ballast (7.5 m³/h)
- large gas ballast (18 m³/h)
- gas ballast with electromagnetical valve (7.5 m³/h) - See § 2.5.2

On pumps supplied without gas ballast valve, the valve can be retrofitted. The gas ballast flows are indicative and valid at ultimate pressure.

Unintentional venting of the vacuum chamber as well as oil suckback when shutting down the pump are prevented by the integrated anti suck-back valve .

In applications where an oil suckback must be avoided by all means, it is recommended to install a dedicated valve.

1.1.1 Range of use

SOGEVAC pumps are designed for pumping of inert gases in the range of rough vacuum, between atmospheric pressure and ultimate pressure of the pump.

SOGEVAC pumps are not designed for pumping of aggressive, corrosive, flammable or explosive gases. By presence of aggressive, flammable, corrosive or explosive gases, contact Oerlikon Leybold Vacuum. These pumps are not designed for working in flammable or explosive environment.

In case of doubt, contact Oerlikon Leybold Vacuum for the ATEX pump range.

The pumps are not suitable for pumping liquids or media which contain dust. Corresponding protective measures must be introduced.

In case of doubt, contact Oerlikon Leybold Vacuum.

Before pumping greater than atmospheric concentrations of oxygen (> 20 %) or other highly reactive gases, the pump must be modified, degreased and a special oil (such as PFPE) must be used

Take adequate safety precautions. Contact Oerlikon Leybold Vacuum for important safety instructions.

1.2 Standard Specification

The pump is supplied with drive motor in ready-to-use condition. It is supplied with GS77 mineral oil, which is filled in.

Specific variants are delivered with different oils. In any case, the oil type is indicated on the pump. No warranty claims could be accepted with use of another oil than specified.

The connection ports are blanked off by plastic protective caps.

Take these caps away before turning on the pump.

Warning



Caution

Description

1.3 Technical Data

		50Hz	60Hz
Nominal speed ¹⁾	m ³ .h ⁻¹	280	340
Pumping speed ¹⁾	m ³ .h ⁻¹	240	290
Ultimate partial pressure without gas ballast	mbar	≤ 8.10 ⁻²	≤ 8.10 ⁻²
Ultimate total pressure with gas ballast	mbar	≤ 0,7	≤ 0,7
Water vapour tolerance with standard gas ballast ¹⁾	mbar	30	40
Water vapour tolerable load with gas ballast	kg.h ⁻¹	5,4	7,4
Water vapour tolerance with big gas ballast ¹⁾	mbar	60	70
Water vapour tolerable load with big gas ballast ¹⁾	kg.h ⁻¹	10	12,5
Noise level ²⁾	dB(A)	70	74
Leak rate	mbar.l.s ⁻¹	≤ 1.10 ⁻³	≤ 1.10 ⁻³
Mains voltage (std) - for other voltages please contact Oerlikon Leybod Vacuum	V	230/400	460 ⁴⁾
Motor power	kW	5,5	6,3
Type of protection		IP55	IP55 ³⁾
Rated rotational speed	min.-1	1450	1750
Weight (with oil filling)	kg	200	200
Oil capacity (min./max.)	l	8,5/11,5	8,5/11,5
Intake connection		G2	G2 NPT2 ³⁾

1) according to DIN28400 and following numbers, with standard gas ballast

2) operated at ultimate pressure without gas ballast, free-field measurements at a distance of 1m

3) please contact Oerlikon Leybold Vacuum

4) CEI : 460V / NEMA : 200-230/460 V

Ordering data Ref. No.	SV300 B
Pump with three-phase motor CEI w/o gas ballast 230 V/400 V, 50Hz 460 V, 60Hz	960 700
Pump with three-phase motor CEI and integrated gas ballast valve 230 V/400 V, 50Hz 460 V, 60Hz	960 702
Pump with three-phase motor NEMA 208V +/-10% and 230/460 +/-10%, 60Hz 400V +/-10% 50Hz	960 707
Pump with three-phase motor JIS and integrated gas ballast valve 200V +10% -15%, 50/60Hz	960 712

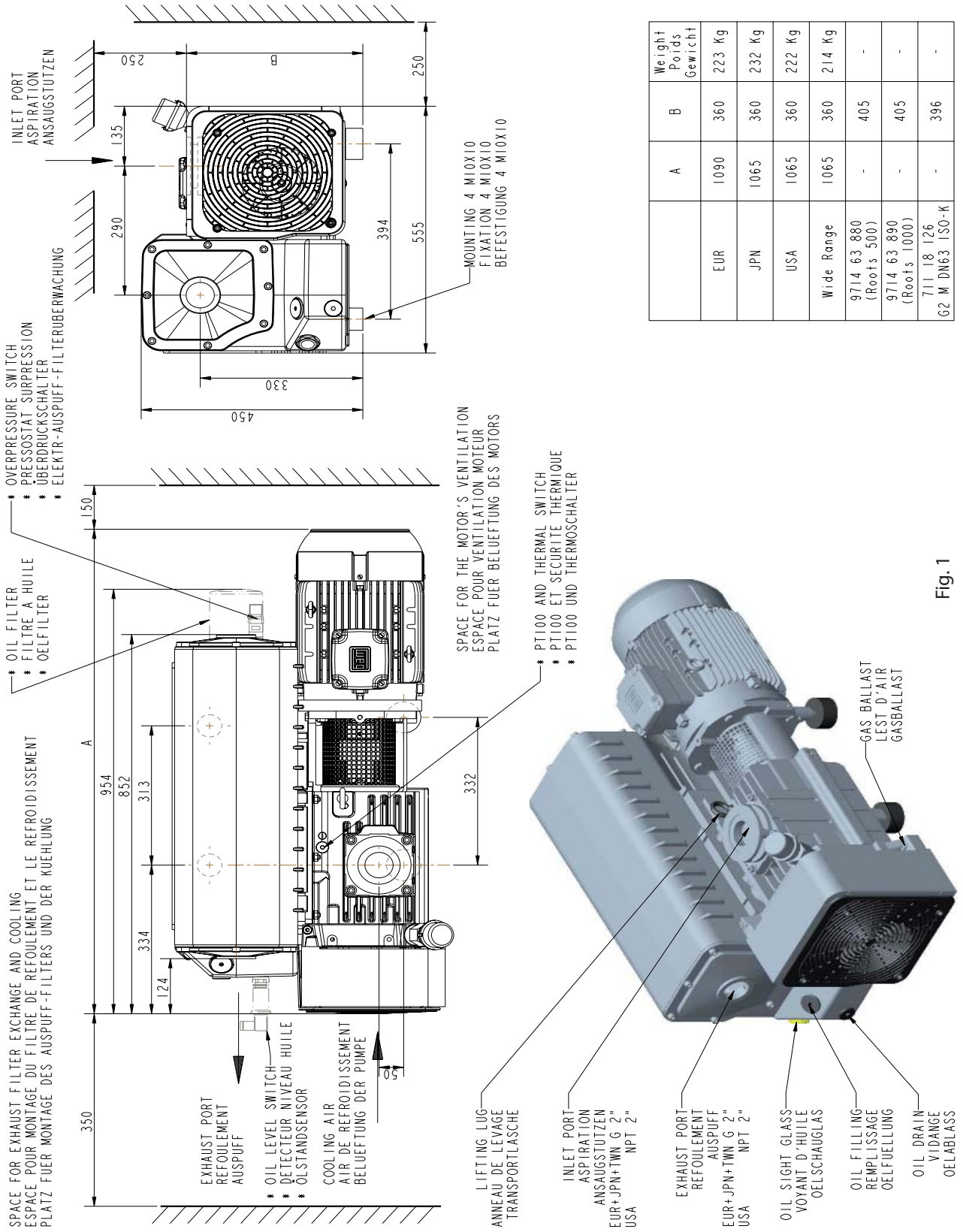

Fig. 1

* OPTION Tolérances : ±5mm

971464209

Description

Conversion factors

Different pressure units

	mbar (millibar)	torr	inches Hg vacuum
1 lb = 0.453 kg	1013	760	0
1 qt = 0.946 l	400	300	18.12
1 hp = 0.735 kW	133	100	25.98
1 inch = 25.4 mm	4	3	29.80
1 r.p.m. = 1 min -	1	0,75	29.89
	0,1	0,75	29.92

1 atm (atmosphere) = 1013 mbar
 1 Pa (pascal) = 0.01 mbar = 10⁻² mbar
 1 bar = 1000 mbar
 1 torr = 1.33 mbar

Different pumping speed units

	m ³ .h ⁻¹	l.s ⁻¹	cfm
m ³ .h ⁻¹ = m ³ /h 1	1	0.278	0.589
l.s ⁻¹ = l/s	3.60	1	2.12
cfm (cubic feet per minute)	1.699	0.472	1

Example : 1 m³.h⁻¹ = 0.589 cfm

Note : the nominal pumping speed of a pump at 60Hz is 20% higher than at 50Hz

		60Hz
Nominal speed ¹⁾	cfm	200
Pumping speed ¹⁾	cfm	171
Ultimate partial pressure without gas ballast	Torr	6.10 ⁻²
Ultimate total pressure with gas ballast	Torr	0.5
Water vapour tolerance with standard gas ballast standard ¹⁾	Torr	≤ 30
Motor power	hp	10.5
Rated rotational speed	rpm	1750
Weight (with oil filling)	lb	430
Oil capacity (min./max.)	qt	9/12.2
Intake connection NPT (F)	inches	NPT2
Exhaust connection NPT (F)	inches	NPT2

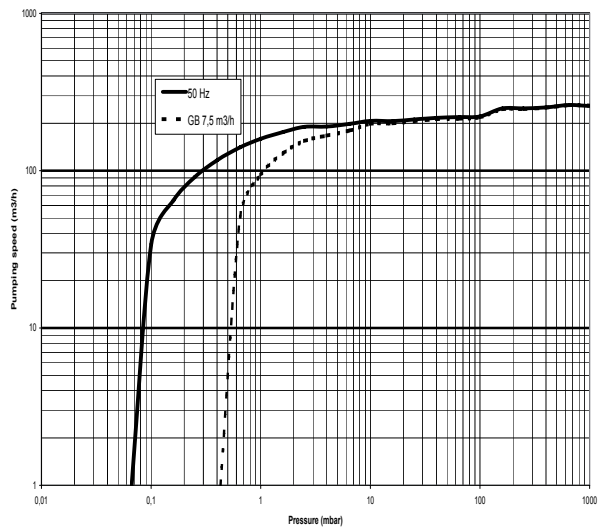

at 50Hz

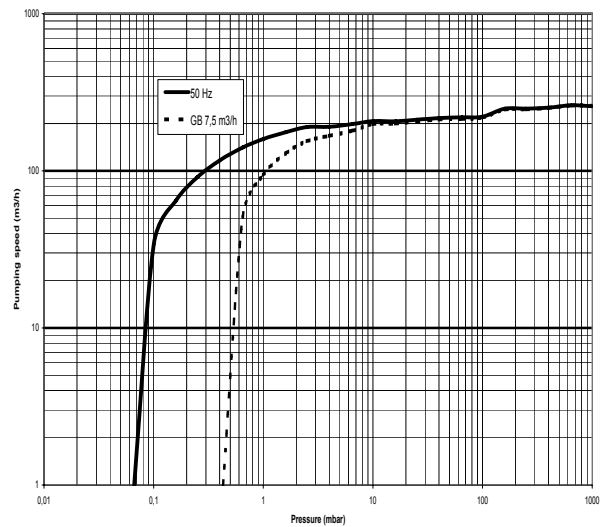

at 60Hz

— without gas ballast

- - - with gas ballast

Fig. 2

1.4 Connection fittings

Item	Description	Size	Cat. Nr.
1	Union coupling + seal	G2 F/M	711 18 025
2	Nipple	G2 M/M - 150 mm long	711 18 035
3	Threaded flange adapter	G2 M - DN 63 ISO-K	711 18 126
4	Centering ring	63 ISO-K AL/NBR	268 07
5	Set of 4 clamps for ISO-K flanges	M10 x 24	267 01
6	Adapter for tubing	G2 DN 50	711 18 015
7	PVC tubing	50 mm, 1 m long	711 18 325
8	Adapter for tubing	G2 DN 60	711 18 016
9	PVC tubing	60 mm, 1 m long	711 18 326
10	Right-angle bend 90°	63 ISO K	887 25
11	Dust filter, paper Dust filter, charcoal Dust filter metal Dust filter polyester	63 ISO K	951 68 711 27 125 711 27 126 711 27 127
12	Ball valve	G2 F/F	711 30 107
13	Tee reducer bush	G2-G2-G1/2 F/F/F	711 18 265
14	Elbow 90°	G2 F/F	711 18 215
15	Dust filter, paper Dust filter, charcoal Dust filter, metal Dust filter polyester	G2 M/F	951 65 711 27 122 711 27 123 711 27 124
16	Vacuum gauge	G1/2 M	951 92
17	Ball valve	G1/2 M/F	711 30 113
18	Threaded flange adapter	G1/2 M - DN 16 KF	711 18 120
19	Regulation valve with isolation valve	G1/2 M	951 87
20	Regulation valve	G1/2 M	951 86
21	Condensate Trap	G2 F -G2 F	951 44

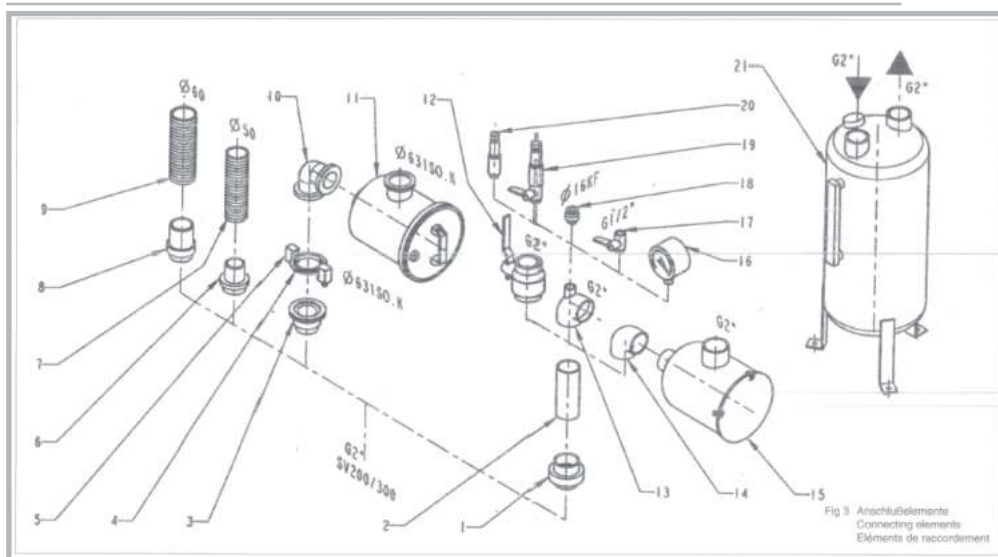

Fig. 3

Description

1.5 Accessories

Description	Size	Cat. Nr.
Oil filter by-pass		712 30 573
Oil drain tap	G" ¾	711 30 114
Gas ballast kit manual ("small", "standard", "big")		9 714 64 130
Gas ballast standard with EM valve 24 V DC (retrofit kit)		Upon request
Exhaust filter gauge		951 94
Exhaust filter overpressure switch		Upon request
Oil level monitor		Upon request
Thermal switch (105°C)		9 714 63 930
PT100		9 714 64 020
Adapter Roots 500		9 714 63 880
Adapter Roots 1000		9 714 63 890
Base frame for pump only		711 19 208
Base frame for Roots direct mounting		9 714 56 590
Water cooling with thermostatic valve		upon request
Separator SEP 63		953 56
Separator SEP 63 stainless steel		953 57
Separator - Condenser SEPC 63		953 66
Separator - Condenser SEPC 63 stainless steel		953 67

* Please consult us for retrofit

Stability of pump is insured with accessories of Oerlikon Leybold Valence; mounting of any other accessory will engage the responsibility of user concerning stability of pump.

1.6 Spare parts

Description	Size	9 714 64 970Cat.Nr.
Oil filter standard		710 18 850
Exhaust filter		9 714 31 120
Set of seals	FKM	9 714 64 950
Repair set		9 714 64 960
Module kit	G2"	9 714 47 390
Module kit	NPT2"	9 714 58 970

1.7 Lubricants

Unless otherwise specified on the pump, we recommend to run the Sogevac pumps with GS77 from Oerlikon Leybold Vacuum or an equivalent oil which meets following requirements and is approved by OLV:

- low vapor pressure, even at high temperatures ;
- flat viscosity curve ;
- minimum water content and absorption ;
- good lubricating properties ;
- resistant to aging under mechanical strain.

If you use a non-approved oil, we cannot guarantee that our pumps will meet their operating specifications (ultimate pressure, pumping speed, operating temperature, etc). However, the warranty is voided only if the nonapproved oil adversely affects the operation or reliability of the pump.

When using other oil brands, employ nondetergent mineral oils of viscosity class ISO VG68 to ISO VG 100.

Use of other special-grade lubricants for specific applications is possible. Please consult us.

Only use lubricants which have been fully qualified by Oerlikon Leybold Vacuum.

Pump oil GS77	Ref. No.
5 liters	711 17 774
25 liters	711 17 776
200 liters	711 17 779

1.8 Manipulation and stock

Pumps which have been filled with operating agent must only be moved in the upright position (horizontally). The angle of slope may not be over 10° max. Otherwise oil may escape. Avoid any other orientations during transportation.

Check the pump for the presence of any oil leaks, because there is the danger that someone may slip on the oil which has leaked from the pump. Only use the lifting lugs which are provided on the pump to lift the pump with the specified lifting devices.

Caution

Warning



Until the pump is put back in to service again, the pump should be stored in a dry place, preferably at room temperature (20 °C). Before taking the pump out of service, it should be properly disconnected from the vacuum system, purged with dry nitrogen and oil should be exchanged too. The inlet and exhaust ports of the pump must be blanked off using the shipping seals which are included upon delivery of the pump. The gas ballast must be closed and if the pump is to be shelved for a longer period of time it should be sealed in a plastic bag together with a desiccant (Silicagel).

If the pump has been shelved for more than one year, standard maintenance must be run and oil must be exchanged too before the pump is put in to service again. We recommend that you contact the service from Oerlikon Leybold Vacuum.

2 Operation

2.1 Installation

It is essential to observe the following instructions step by step to ensure a safe start-up. Start-up may only be conducted by trained specialists.

The SOGEVACs can be set up on any flat, horizontal surface. Under the four feet, there are metric threaded holes for securing the pump.

The oil level cannot be read properly if the pump is tilted. Pump risks to run dry. The ambient temperature should be between 12°C (55°F) and 40°C (104°F) depending on oil type. By modifying the pump or changing the oil type, the pump can be run at a lower ambient temperature. Please consult us about this.

To ensure adequate cooling of the pump, leave enough space at the air intake and exhaust points, so as for access and maintenance. Make sure to keep the air intake of motor clear.

2.2 Connection to system

The standard pump is not suitable for installation in explosion hazard areas. Please contact us, when you are planning such an application. Before installing the pump you must reliably disconnect it from the electrical power supply and prevent the pump from running up inadvertently. The pump must only be installed by suitably qualified and trained personnel.

Observe all safety regulations.

Caution

Caution

Operation

2.2.1 Intake Side

The pump has an internally-threaded intake flange. Using suitable connecting elements (see Fig. 3 and Section 1.4), the pump can be connected to the vacuum system.

The cross-section of the intake line should be at least the same as the intake port. If the intake line is too narrow, it reduces the pumping speed.

We recommend applying either LOCTITE or TEFLON tape to the screwed unions so that they are vacuum-tight (especially if gases are dangerous).

Warning



- Pump should be connected to inlet line without any tension. Use flex lines or pipe unions in your inlet and exhaust lines so that they can be easily removed for pump maintenance.

- The maximum pressure at the inlet may not exceed atmospheric pressure (about 1013 mbar). Never operate the pump in the presence of over pressures at its intake.

- Type of materials used for mounting of canalisations should take care of pumped gases. It is the same for its tightness.

If the process gas contains dust or particles, it is absolutely essential to install a dust filter in addition to the dust trap supplied (see Section 1.4). We recommend to install the dust filter horizontally using the T-piece (3/13) or the elbow (3/14). This ensures that when removing the filter, no particle falls into the intake port.

You have a choice of four cartridges for the optional inlet filters. The metal cartridge prevents solid particles such as paper or plastics from entering the pump ; the paper and polyester cartridges remove small particles such as dust and powder down to one micron ; the activated carbon cartridge absorbs chemical vapors of acids, solvents, etc. If the carbon cartridge was stored in a damp place, bake it for 2 hours at 212°F (100°C) before use.

When pumping vapors, we recommend installing condensate traps or condensers on the intake side (see Section 1.4).

By pumping of dangerous gases, inlet line must be tight.

No particles or liquids may enter in the pump.

2.2.2 Exhaust Side

The SOGEVACs have integrated exhaust filters which, even at a high gas throughput, trap the oil mist and guarantee exhaust gas free of oil mist. If the exhaust filters are clogged, pressure relief valves opens and the filters are bypassed. As a result, the proportion of oil in the exhaust gas as well as the pump's oil consumption rise. Installing new exhaust filters will correct this problem. (See Section 3.9)

Warning



This situation must be resolved by changing the exhaust filters. It is under utiliser's responsibility to assure maintenance on materiel to avoid any trespassement of the limits autorised by regulations.

Check in the individual case whether an exhaust line is necessary and/or prescribed. Volatile substances can pass through the filter. Depending on the processed gas, we recommend connecting an exhaust line ; this is always necessary when the exhaust gases are dangerous.

Operation

Warning



Observe the safety precautions that apply to your application and process gases. The pump's exhaust port also has an internal thread (ET3/18). A hose can be connected via a suitable screw-in nipple (see Fig. 3 and Section 1.4).

The cross-section of the exhaust line should be at least the same as the pump's exhaust port. If the exhaust line is too narrow, overpressure may occur in the pump.

Before installing the exhaust line, remove the exhaust-flange plate and ensure that the exhaust demister(s) are secured tightly in place. They sometimes loosen during shipping and installation. A loose demister results in exhaust smoke during start-up and operation.

Install the exhaust line with a downward slope to prevent condensate from flowing back into the pump. If this is not possible, we strongly recommend installing a condensate trap (see Section 1.5). If several pumps are connected to one exhaust line, ensure an adequate cross-section and a non-return valve at the exhaust of each pump.

Never operate the pump with a blocked or restricted exhaust line. Before start-up ensure, that any blinds or similar shut-off devices in the exhaust line on the pressure side are opened and that the exhaust line is not obstructed. Such restrictions reduce the pumping speed, increase the temperature, and could overload the motor or cause a dangerous overpressure in the pump. Excessive pressure in the pump could damage the seals, blow out the sight glass, or destroy the pump housing. In addition to this explosion hazard, excessive backpressure can result in hazardous process gases leaking out of the pump. If you are purging the oil casing with inert gas, limit the inert-gas flow. Contact Oerlikon Leybold Vacuum for recommendations.

When pumping dangerous gases, exhaust line must be tight.

The maximum exhaust pressure must not exceed 1,15 bar (absolute). Also reliably prevent the occurrence of any blockage in the exhaust line. Exhaust filter, accessories and the tubing must be rated according to the maximum throughput. The maximum throughput is equivalent to the pumping speed of the pump.

Warning



2.3 Electrical Connections (See fig. 4)

Ensure that incoming power to the pump is off before wiring the motor or altering the wiring. Electrical connections must be done by a qualified electrician in accordance with the applicable safety regulations.

Wire the motor for the correct supply voltage via connections in the junction box. See the wiring diagram on the motor or in the junction box. For proper connection, a suitable motor protection switch must be used. Set the switch in accordance with the rating on the motor nameplate. The switch should be of class 10 at least.

After connecting the motor and every time you alter the wiring, check the direction of rotation. Observe the direction arrow on the motor hood. During the check, the intake port should be open. If the direction of rotation is wrong, oil may be ejected out the intake port. The vacuum system may be pressurised.

Don't use the motor fan for checking the rotation direction. The motor fan rotates too fast to clearly check during operation ; when it slows during shutdown, it reserves its direction.

Turn off the power supply, and interchange two phases of the connection, if you need to correct the direction of rotation.

We recommend checking the direction of rotation with a phase-sequence indicator.

Prolonged running of the motor in the wrong direction of rotation will damage the pump !

A thermal overload switch is available as an accessory. It cuts out the pump if a specific temperature is exceeded and/or triggers a warning signal.

If any security switch or electrical defect cuts out the pump, re-start-up of the pump is only possible by hand-action.

Warning

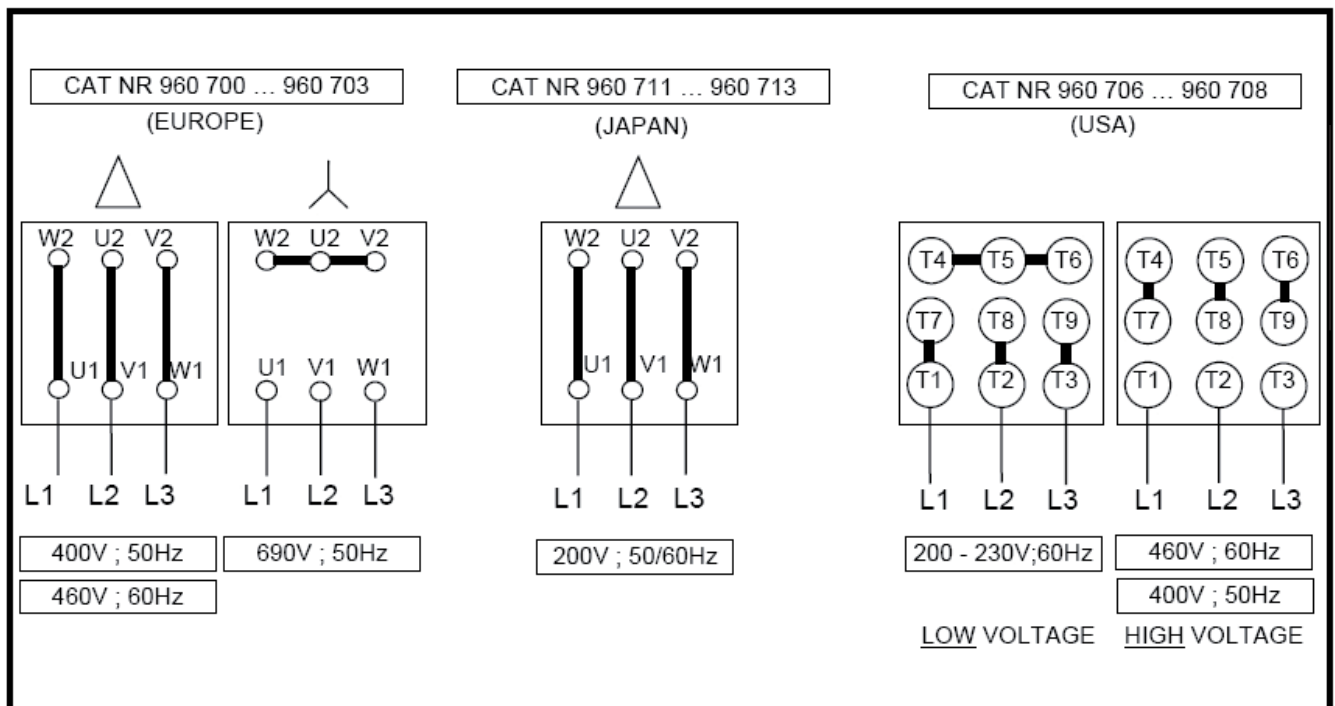
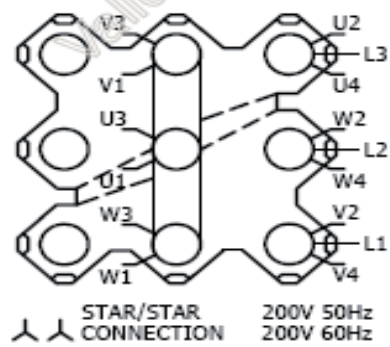
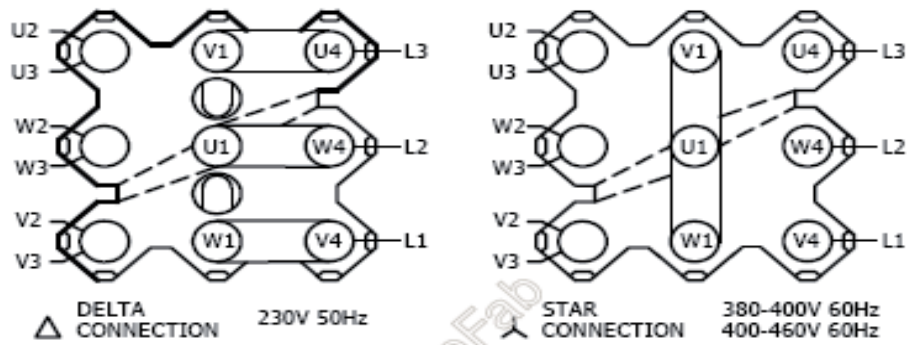

Fig. 4

Operation

CAT NR 960 716 ... 960 718

WIDE-RANGE



Operation

2.4 Start-up

Oil for the first filling is supplied with the pump.

Caution

Before switching on, always make sure that the pump contains enough oil. The normal oil level is in the middle of sight glass.

If oil has to be added, unscrew the oil-fill plug, add oil and screw the plug firmly back in.

The SOGEVAC is designed for normal startup at temperatures over 0°C (32°F) (as per PNEUROPE), depending on used oils.

To avoid overloading the motor, do not start the pump more than six times within one hour. If frequent starts are needed, the pump should run continuously and be linked to the vacuum vessel by means of a valve. In that case, regulation will be made by the valve and not by start/stop of the pump. With the valve closed, the pump consumes little energy.

Warning



-Before starting the pump ensure that the attached accessories meet the requirements of your application and that safe operation is ensured.

-Never expose part of the body to the vacuum. There is a danger of injury. Never operate the pump with an open and thus accessible inlet. Vacuum connections as well as oil filling and oil draining openings must not be opened during operation of the pump.

-The safety regulations which apply to the specific application in each case must be observed. This applies in particular to installation, operation and maintenance (servicing) as well as waste disposal and transportation.

Do not lay the hand on the intake to check vacuum.

Exposure of a part of the body to the vacuum result in a rush of blood in the exposed part.

2.5 Operation

The SOGEVAC can pump gases and vapors, provided that the gas ballast valve is installed and open and the pump has reached its operating temperature.

Contact Oerlikon Leybold Vacuum for important safety instructions before pumping greater than atmospheric concentrations of oxygen or other highly reactive gases. The pump must be degreased, modified, and special inert oil must be used for pumping oxygen. Also ATEX variants are available for pumping explosive gases.

The motor manufacturer guarantees a maximum of 6 starts per hour. To avoid exceeding 6 starts per hour, run the pump continuously and regulate the vacuum in your system with a pilot valve.

Warning



Pump in operation is hot and some surfaces could reach a temperature higher than 80°C (176°F). There is a risk of burn by touching. Take note of warning labels on the pump.

2.5.1 Pumping of Non-condensable Gases

If the process contains mainly permanent gases, the SOGEVACs can be operated without gas ballast, provided that the saturation vapor pressure at operating temperature is not exceeded during compression.

If you do not know the composition of the gases to be pumped, and if you can't rule out the possibility of condensation, run the pump with gas ballast valve open in accordance with Section 2.5.2.

2.5.2 Pumping of Condensable Gases and Vapors. Using gas ballast.

The pumps with gas ballast valves are delivered with the gas ballast valve open.

The SOGEVAC SV300 B can be equipped with following types of gas ballasts :

- Standard gas ballast . This gas ballast corresponds to the most important part of applications .
- Gas ballast «big flow» as a variant or accessory is intended for the applications where more vapours of condensable gases could come into the pump.
- Gas ballast "small flow" for pumping on applications where only few vapours are to be pumped and where the ultimate pressure with open gas ballast is important.
- Gasballast with E.M. valve (Cat. No. upon request) This kit is intended for being mounted on pumps on which the gasballast can be driven by an electromagnetic valve applied at 24 VDC.

A gas ballast kit Including all material required for changing the manual gas ballast flow to "small", "standard" or "big" is available: P/N 9 714 64 130

With the gas ballast valve open and at operating temperature, the SOGEVAC's can pump pure water vapor up to the water vapor tolerance indicated in the Technical Data. The pump's water vapor tolerance can be increased by raising the operating temperature.

Use a screwdriver to open the gas ballast valve. The running noise of the pump is slightly louder when the gas ballast valve is open. Before opening the pump to vapors, ensure that the gas ballast valve is open and that the pump has been warmed up for about 30 minutes with closed intake line.

Important

Do not open the pump to condensable vapors until it has warmed to operating temperature ; pumping process gas with a cold pump results in vapors condensing in the oil.

For processes with a high proportion of condensable vapors, slowly open the intake line, after reaching the operating temperature to prevent excessive quantities of vapor entering the pump.

One sign of condensation of vapors in the pump is a rise in the oil level during operation of the pump.

During pumping, vapors may dissolve in the oil. This changes the oil properties and causes a risk of corrosion in the pump. Therefore, do not switch off the pump immediately after completion of the process. Instead, allow the pump to continue operating with the gas ballast valve open and the intake line closed until the oil is free of condensed vapors. We strongly recommend operating the pump in this mode for about 30 minutes after completion of the process.

Operation

Note

In cyclic process operation, the pump should not be switched off during the intervals between the individual working phases, but should continue to run with gas ballast valve open and intake port closed (if possible via a valve). Power consumption is minimal when the pump is operating at ultimate pressure. Once all vapors have been pumped off from a process (e.g. during drying), the gas ballast valve can be closed to improve the ultimate pressure.

2.5.3 Working in cycles in / out

We recommend strongly to limit starting of the pump to 5 or 6 per hour. If the process need it, we recommend utilisation of a pneumatic or electromagnetic piloted valve and to let the pump run continuously.

2.6 Shutdown

Under normal circumstances, all that you need to do is to switch off the pump. The intake port of the SOGEVAC contains an anti-suckback valve, which closes the intake port when the pump is shut down, thus maintaining the vacuum in the connected system and preventing oil from being sucked back into the system. The valve's functioning is not impaired by gas ballasting, but its cleanliness must be taken care of.

When pumping condensable media, let the pump continue to operate with the gas ballast valve open and the intake line closed before switching off (see Section 2.5.2).

Warning



If the pump is to be shut down for an extended period or if the pump has to be stored, proceed as follows: When pumping harmful substances, take adequate safety precautions.

Drain the oil (see Section 3.3). Pour in clean oil up to the bottom edge of the oil-level glass (see Section 3.3) and let the pump run for a few minutes.

Then drain the oil and pour in clean oil up to the top edge of the oil-level glass (see Section 3.3). Seal the connection ports. Special preservation or slushing oils are not necessary.

When the pump has been switched off due to over-heating, initiated by the motor or its protection, the pump must be cooled down to the ambient temperature, and must only be switched on again manually after having eliminated the cause. In order to prevent the pump from running up unexpectedly after a main power failure, the pump must be integrated into the control system in such a way that the pump can only be started by a manually operated switch. This applies equally to emergency cut-off switches.

In case of switching processes in connection with a pump which has warmed up under operating conditions, the pump must then not be directly switched on again.

2.7 Pump Ultimate Pressure

If the system cannot reach the pressures specified in the technical data, measure the ultimate pressure directly at the pump's intake port after disconnecting the pump from the system.

The ultimate pressure of non-condensable gases (partial pressure of air) can only be measured with a compression vacuum gauge or a partial pressure gauge. Precise measurements can only be obtained with calibrated instruments. Upon initial start-up, after prolonged idle periods or after an oil change, it takes a while until the pump reaches the specified ultimate pressure. The pump has to attain its operating temperature, and the pump oil has to be degassed. We

The ultimate pressure depends on the pump temperature and the pump oil used. The best ultimate pressure can be obtained at a low pump temperature and by using the recommended oil types.

3 Maintenance

Disconnect the power before disassembling the pump. Make absolutely sure that the pump cannot be accidentally started.

If the pump has pumped harmful substances, ascertain the nature of the hazard and take adequate safety measures.

Observe all safety regulations.

Service at Oerlikon Leybold Vacuum's

If you send a pump to Oerlikon Leybold Vacuum indicate whether the pump is free of substances damaging to health or whether it is contaminated. If it is contaminated also indicate the nature of hazard. For this you must use the form «Declaration of Contamination of Vacuum Instruments and Components», which is reproduced at the end of the Operating Instructions.

Please attach this form to the pump, or enclose it with it. This Declaration is required to meet the law and to protect our personnel.

Oerlikon Leybold Vacuum will return any pump received without a «Declaration of Contamination» to the sender's address.

The pump must be packaged in such a way that it will not be damaged during shipping, and so that no harmful substances can escape from the package.

If you open a pump at your own works also observe a potential contamination. When disposing of used oil, please observe the relevant environmental regulations. Due to the design concept, SOGEVAC pumps require very little maintenance under normal operating conditions. The work required is described in the sections below.

All work must be done by suitably trained personnel. Maintenance or repairs carried out incorrectly will affect the life and performance of the pump and may cause problems when filing warranty claims.

3.1 Maintenance Schedule

The frequencies stated in the maintenance schedule are approximate values for normal pump operation.

Unfavourable ambient conditions and/or aggressive media may necessitate more frequent maintenance.

Warning



Warning



Maintenance

Maintenance job	Frequency	Section
Check the oil level	daily	3.2.1
Check the oil condition	Depends on process	3.2.2
1st oil change	After 150 h of operation	3.3
Subsequent oil changes	Every 1000 h of operation or 3 months	3.3
Replace the oil filter	At each oil change	3.3
Clean the dirt trap	monthly	3.4
Check the anti-suckback valve	annually	3.5
Radiator cleaning	depends on ambient conditions	3.8
Exhaust filter change	if oil mist at exhaust or annually	3.9
Ball bearing greasing	Every 30 000 h	

To simplify the maintenance work we recommend combining several jobs.

Caution



Never mount used seals. Always mount new seals.

3.2 Checking the Oil

3.2.1 Oil Level

The pump oil level during operation must always be in the middle of the oil-level glass (ET3/24). When necessary, switch off the pump and add the correct quantity of oil.

High oil consumption often indicates that exhaust filters are clogged (See 3.9). Stop the pump for filling oil. The oil level should be checked at least once a day

3.2.2 Oil Condition GS77

Normally the oil is clear and transparent. If gases or liquids dissolved in the oil result in deterioration of the ultimate pressure, the oil can be degassed by allowing the pump to run for about 30 min. with the intake port closed and the gas ballast valve open.

The amount of oil required for an oil check should be drained via the oil-drain plug (ET3/19) into a beaker or similar container with the pump switched off but still at operating temperature.

Depending on the process involved, dangerous substances may escape from the pump and oil. Take the appropriate precautions.

Observe the safety regulations.

Warning



3.3 Oil Change, Replacing the Oil Filter

Tool required: oil filter key (710 73 532)

Always change the oil when the pump is switched off but still at working temperature.

If there is a risk of the oil being polymerized by the connected process, change the oil immediately after operation of the pump.

Pump in function is hot and some surfaces could reach a temperature higher than 80 °C (176 °F).

There is a risk of burn by touching.

Unscrew the oil-drain plug and let the used oil drain into a suitable container.

Depending on the process involved, dangerous substances may escape from the pump and oil. Take the appropriate precautions.

Observe the safety regulations.

When disposing of used oil please observe the relevant environmental regulations!

When the flow of oil slows down screw the oil-drain plug back in, briefly switch on the pump (max. 10s) and switch it off. Remove the oil-drain plug again and drain the remaining oil.

Unscrew the oil filter. Take a new oil filter, moisten its gasket with oil and screw it in manually.

Reinsert the oil-drain plug (check the O-Ring and replace it with a new one if necessary).

Unscrew the oil-fill plug and fill the pump should be flushed by filling it with fresh oil up to the bottom edge of the oil-level glass, run it for a short time and then change the oil again.

Use suitable oil only (see Section 1.8).

Warning



Important

Maintenance

3.4 Cleaning the Dirt Trap

Required tools: Allen key male 8 mm. A dirt trap for coarse particles is located in the intake flange of the pump. It should be kept clean to avoid reduction of the pumping speed.

Remove four screws and take off the intake flange and gasket. Remove the retaining ring and support piece from inside. Take out the wire-mesh screen and clean it with a suitable solvent.

Reassemble in the reverse sequence. We recommend replacing the gasket by a new one.

Depending on the process involved, dangerous substances may escape from the pump and oil. Take the appropriate precautions.

Observe the safety regulations.

When disposing of used oil, please observe the relevant environmental regulations!

Never mount used seals ; always mount new seals.

3.5 Checking the Anti-Suckback Valve

Required tools : Allen key male 8 mm - Adjusting ring: 710 72 333

Keep the anti-suckback valve clean to ensure proper operation of the pump. If the pump is exposed to large amounts of dust or dirt, we strongly recommend installing a dust filter upstream (see Section 1.4).

First disconnect the intake line. Remove four screws and take off the intake flange and gasket. Remove the spring and anti-suckback valve. If the anti-suckback valve closes too soon, carefully compress the spring slightly. The top edge of the valve should be about 1-2 mm away from the bottom side of the intake port.

Warning



Caution

Important

Depending on the process involved, dangerous substances may escape from the pump and oil. Take the appropriate precautions.

Observe the safety regulations.

Never mount used seals ; always mount new seals.

When disposing of used oil, please observe the relevant environmental regulations !

3.6 Cleaning the Gas Ballast Intake Filter

Required tools: none

On the big flow gas ballast, the inlet filter must be changed when the GB flow decreases. Filter P/N 710 20 852

3.7 Disassembly of electrical motor

Disconnect the power before disassembling the pump. Make absolutely sure that the pump cannot be accidentally started.

1. To disassemble motor from coupling housing, unscrew the 4 hexagonal head screws.
2. With the help of an extractor puller, remove the coupling of the motor shaft after having untightened the locking screw by a male Allen key 4 mm.
3. The reassembly is carried out in the reverse sequence.
4. Check direction of rotation.

General Remarks

We reserve the right to alter the design or any data given in these Operating Instructions. The illustrations are not binding.

3.8 Radiator cleaning

Please keep the oil cooler clean to have an efficient cooling. For that, remove the turbine cover and clean it with compressed air from the turbine inside. Then reassemble the cover.

3.9 Exhaust filter exchange

- Remove the screws of the exhaust plate (ET3/18) using a 8 mm Allen key
- Lift the 3 exhaust filters (ET3/25) from the W shaped metal sheet holder and remove them from the oil casing (ET1/1)
- make sure that the new exhaust filters (ET3/25) have the O-ring (opposite side of overpressure valve) and grease them using vacuum grease P/N 711 17 700
- Replace the O-ring (ET3/26p) of the exhaust plate (ET3/18)
- Insert new exhaust filters (ET3/25). They are guided in the oil casing (ET1/1) correct position. Make sure the compression springs (ET3/27) are behind the W shaped metal sheet holder.
- Plug the exhaust plate (ET3/18) on the W shaped metal sheet holder with the 2 location pins and screw the exhaust plate (ET3/18) on the oil casing (ET1/1) using a 8 mm Allen key.

Warning



Troubleshooting guide

4 Troubleshooting

Fault	Possible cause	Remedy	Reference
Pump does not start	Pump is connected incorrectly	Connect the pump correctly	2.3
	Motor protection switch incorrectly set.	Set motor protection switch properly	2.3
	Operating voltage does not match motor	Replace the motor	
	Motor is malfunctioning	Replace the motor	
	Oil temperature is below 12°C (54°F)	Heat the pump and pump oil or use different oil	1.8
	Oil is too viscous	Use appropriate oil grade	3.3
	Exhaust filter / exhaust line is clogged	Replace the filter or clean the exhaust line	3.4
	Pump is seized up (sign : pump is jammed)	Repair the pump	3.11 / 3.12
Pump does not reach ultimate pressure	Measuring technique or gauge is unsuitable	Use correct measuring technique and gauge	2.7
	External leak 1) - Piping fittings loose	Repair the pump - Retighten	
	Float valve does not close	Repair the valve	3.9
	Anti-suckback valve is malfunctioning	Repair the valve	3.6
	Exhaust valve is malfunctioning	Repair the valve	3.10
	Inadequate lubrication due to : - unsuitable or contaminated oil - clogged oil filter - clogged oil lines	Change the oil Replace the oil filter Clean the oil lines and oil case	3.3 3.3
	Vacuum lines are dirty	Clean vacuum lines	
	Pump is too small	Check the process date ; replace the pump, if necessary	
Pumping speed is too low	Dirt trap in the intake port is clogged	Clean the dirt trap. Precaution : install a dust filter in intake line	3.5 1.4/2.2.1
	Exhaust filter is clogged	Install new filter elements	3.4
	Connecting lines are too narrow or too long	Use adequately wide and short connecting lines	2.2
	Anti-suckback valve is hard to open	Check spring free length	
After switching off pump under vacuum, pressure in system rises too fast	System has a leak	Check the system	
	Anti-suckback is malfunctioning	Repair the valve	3.6
Pump gets too hot	Cooling air supply is obstructed	Set pump up correctly	2.1
	Cooler is dirty	Clean the cooler	3.8
	Ambient temperature is too high	Set pump up correctly	2.1
	Process gas is too hot	Change the process	
	Oil level is too low	Add oil to reach the correct oil level	3.3
	Oil is unsuitable	Change the oil	3.3
	Oil cycle is obstructed	Clean or repair the oil lines	
	Exhaust filter / exhaust line is obstructed	Replace the exhaust filter, clean the exhaust line	3.4
	Exhaust valve is malfunctioning	Repair the valve	3.10
Pump module is no longer usable	Replace the pump module	3.11	
Oil in intake line or in vacuum vessel	Oil comes from the vacuum system	Check the vacuum system	
	Anti-suckback valve is obstructed	Clean or repair the valve	3.6
	Sealing surfaces or anti-suckback valve are damaged or dirty	Clean or repair the intake port and valve	3.6
	Oil level is too high	Drain the excess oil	3.3
Oil is turbid	Condensation	Degas the oil or change the oil and clean the pump. Precaution : open the gas ballast valve or insert a condensate trap. Clean the gas ballast intake filter	2.5.2/3.2.2. 3.7
Pump is excessively noisy	Oil level is very low (oil is no longer visible)	Add oil	3.3
	Oil filter is clogged	Change the oil and filter	3.3
	Coupling element is worn	Install new coupling element	3.11
	Large vacuum leak in system	Repair vacuum leak	3.11/3.12

* Reference section : This column refers to the section in the Operating Instructions that contains the applicable repair information. 1) Bubble test : Let the pump run at operating temperature with degassed oil, without gas ballast and with closed intake port. Immerse the exhaust line in a bucket of water. If a steady stream of bubbles appear, the pump has an external leak. NB: For any other operation as described before, return the pump to a Oerlikon Leybold Vacuum service center.

EC Conformance Declaration



We, the Oerlikon Leybold Vacuum France, declare herewith that the products listed below, in the embodiment which we have placed on the market, comply with the applicable EC guidelines.

This declaration becomes invalid if modifications are made to the product without prior consultation with use.

Maintaining the EMC guideline assumes an EMC compliant installation of the component within the plant or machine.

Product type: SOGEVAC

Model designation: SV16, SV25, SV40, SV65, SV10B, SV16B, SV16BI, SV28BI, SV40BI, SV25B, SV40B, SV65B, SV100B, SV100, SV200, SV300, SV300B, SV500, SV630, SV750, SV1200, SV630B, SV750B
and their variants, excepted the pumps delivered without motor and the pumps delivered with EEx... motors

The products comply to the following guidelines :

- EC Directive on machines (98/37/EC)
- EC Low-Voltage Equipment Guidelines (73/23/EEC)+(93/68/EEC)
- EC Directive on Electromagnetic Compatibility (89/336/EEC) / (92/31/EEC) / (93/68/EEC)

Related, harmonized standards:

- EN 1012, 1996
Compressors and vacuum pumps, safety requirements
Part 2: Vacuum pumps
- EN 60204-1, 1997
Safety of machinery - Electrical equipment of machines
Part 1: General requirements

Limits of use:

- The pump and its accessories are not designed for pumping aggressive, flammable, explosive gases or vapors or substances, phyrophoric gases or oxidizing agents.
- The pump and its accessories are not designed for working in aggressive, flammable, or explosive ambience.
- For pumping oxygen in concentrations greater than atmospheric concentration (>20%) or other highly reactive gases, a special pump must be used. This pump must be modified and an inert oil (such as PFPE) must be used.

Contact Oerlikon Leybold Vacuum France for important safety precautions relative to these applications.

Other safety precautions and restrictions:

Refer to the manual delivered with the pumps. In any case, take adequate safety precautions.

Declaration of contamination

Declaration of Contamination of Compressors, Vacuum Pumps and Components

The repair and / or servicing of compressors, vacuum pumps and components will be carried out only if a correctly completed declaration has been submitted. Non-completion will result in delay. The manufacturer can refuse to accept any equipment without a declaration.

A separate declaration has to be completed for each single component.

This declaration may be completed and signed only by authorized and qualified staff.

Customer/Dep./Institute : _____ Address : _____ _____ Person to contact: _____ Phone : _____ Fax: _____ End user: _____	Reason for return: <input checked="" type="checkbox"/> applicable please mark Repair: <input type="checkbox"/> chargeable <input type="checkbox"/> warranty Exchange: <input type="checkbox"/> chargeable <input type="checkbox"/> warranty <input type="checkbox"/> Exchange already arranged / received Return only: <input type="checkbox"/> rent <input type="checkbox"/> loan <input type="checkbox"/> for credit Calibration: <input type="checkbox"/> DKD <input type="checkbox"/> Factory-calibr. <input type="checkbox"/> Quality test certificate DIN 55350-18-4.2.1																																																								
A. Description of the Leybold product: _____ Failure description: _____ Material description : _____ Catalog number: _____ Additional parts: _____ Serial number: _____ Application-Tool: _____ Type of oil (ForeVacuum-Pumps) : _____ Application- Process: _____																																																									
B. Condition of the equipment <table style="width:100%; border-collapse: collapse;"> <thead> <tr> <th style="width:40%;"></th> <th style="width:10%; text-align: center;">No¹⁾</th> <th style="width:10%; text-align: center;">Yes</th> <th style="width:10%; text-align: center;">No</th> <th style="width:10%;"></th> <th style="width:10%;"></th> <th style="width:10%;"></th> </tr> </thead> <tbody> <tr> <td>1. Has the equipment been used</td> <td style="text-align: center;"><input type="checkbox"/></td> <td style="text-align: center;"><input type="checkbox"/></td> <td style="text-align: center;"><input type="checkbox"/></td> <td style="text-align: center;">→</td> <td style="text-align: center;"><input type="checkbox"/></td> <td style="text-align: center;"><input type="checkbox"/></td> </tr> <tr> <td>2. Drained (Product/service fluid)</td> <td style="text-align: center;">↓</td> <td style="text-align: center;"><input type="checkbox"/></td> <td style="text-align: center;"><input type="checkbox"/></td> <td></td> <td style="text-align: center;"><input type="checkbox"/></td> <td style="text-align: center;"><input type="checkbox"/></td> </tr> <tr> <td>3. All openings sealed airtight</td> <td style="text-align: center;">↓</td> <td style="text-align: center;"><input type="checkbox"/></td> <td style="text-align: center;"><input type="checkbox"/></td> <td></td> <td style="text-align: center;"><input type="checkbox"/></td> <td style="text-align: center;"><input type="checkbox"/></td> </tr> <tr> <td>4. Purged</td> <td style="text-align: center;">↓</td> <td style="text-align: center;"><input type="checkbox"/></td> <td style="text-align: center;"><input type="checkbox"/></td> <td></td> <td style="text-align: center;"><input type="checkbox"/></td> <td style="text-align: center;"><input type="checkbox"/></td> </tr> <tr> <td colspan="4">If yes, which cleaning agent _____</td> <td></td> <td style="text-align: center;"><input type="checkbox"/></td> <td style="text-align: center;"><input type="checkbox"/></td> </tr> <tr> <td colspan="4">and which method of cleaning _____</td> <td></td> <td style="text-align: center;"><input type="checkbox"/></td> <td style="text-align: center;"><input type="checkbox"/></td> </tr> <tr> <td colspan="4"> ¹⁾ If answered with "No", go to D. ← </td> <td></td> <td style="text-align: center;"><input type="checkbox"/></td> <td style="text-align: center;"><input type="checkbox"/></td> </tr> </tbody> </table>			No ¹⁾	Yes	No				1. Has the equipment been used	<input type="checkbox"/>	<input type="checkbox"/>	<input type="checkbox"/>	→	<input type="checkbox"/>	<input type="checkbox"/>	2. Drained (Product/service fluid)	↓	<input type="checkbox"/>	<input type="checkbox"/>		<input type="checkbox"/>	<input type="checkbox"/>	3. All openings sealed airtight	↓	<input type="checkbox"/>	<input type="checkbox"/>		<input type="checkbox"/>	<input type="checkbox"/>	4. Purged	↓	<input type="checkbox"/>	<input type="checkbox"/>		<input type="checkbox"/>	<input type="checkbox"/>	If yes, which cleaning agent _____					<input type="checkbox"/>	<input type="checkbox"/>	and which method of cleaning _____					<input type="checkbox"/>	<input type="checkbox"/>	¹⁾ If answered with "No", go to D. ←					<input type="checkbox"/>	<input type="checkbox"/>
	No ¹⁾	Yes	No																																																						
1. Has the equipment been used	<input type="checkbox"/>	<input type="checkbox"/>	<input type="checkbox"/>	→	<input type="checkbox"/>	<input type="checkbox"/>																																																			
2. Drained (Product/service fluid)	↓	<input type="checkbox"/>	<input type="checkbox"/>		<input type="checkbox"/>	<input type="checkbox"/>																																																			
3. All openings sealed airtight	↓	<input type="checkbox"/>	<input type="checkbox"/>		<input type="checkbox"/>	<input type="checkbox"/>																																																			
4. Purged	↓	<input type="checkbox"/>	<input type="checkbox"/>		<input type="checkbox"/>	<input type="checkbox"/>																																																			
If yes, which cleaning agent _____					<input type="checkbox"/>	<input type="checkbox"/>																																																			
and which method of cleaning _____					<input type="checkbox"/>	<input type="checkbox"/>																																																			
¹⁾ If answered with "No", go to D. ←					<input type="checkbox"/>	<input type="checkbox"/>																																																			
C. Description of processed substances (Please fill in absolutely) <table style="width:100%; border-collapse: collapse;"> <tr> <td colspan="2"> 1. What substances have come into contact with the equipment ? Trade name and / or chemical term of service fluids and substances processed, properties of the substances According to safety data sheet (e.g. toxic, inflammable, corrosive, radioactive) </td> </tr> <tr> <td style="width:5%; text-align: center;">X</td> <td style="width:40%;">Tradename: _____</td> <td style="width:55%;">Chemical name: _____</td> </tr> <tr> <td></td> <td>a) _____</td> <td>_____</td> </tr> <tr> <td></td> <td>b) _____</td> <td>_____</td> </tr> <tr> <td></td> <td>c) _____</td> <td>_____</td> </tr> <tr> <td></td> <td>d) _____</td> <td>_____</td> </tr> <tr> <td colspan="2"> 2. Are these substances harmful ? </td> <td style="text-align: center;"> <table style="width:100%; border-collapse: collapse;"> <tr> <td style="width:50%; text-align: center;">No</td> <td style="width:50%; text-align: center;">Yes</td> </tr> <tr> <td style="text-align: center;"><input type="checkbox"/></td> <td style="text-align: center;"><input type="checkbox"/></td> </tr> </table> </td> </tr> <tr> <td colspan="2"> 3. Dangerous decomposition products when heated ? </td> <td style="text-align: center;"> <table style="width:100%; border-collapse: collapse;"> <tr> <td style="width:50%; text-align: center;">No</td> <td style="width:50%; text-align: center;">Yes</td> </tr> <tr> <td style="text-align: center;"><input type="checkbox"/></td> <td style="text-align: center;"><input type="checkbox"/></td> </tr> </table> </td> </tr> <tr> <td colspan="2">If yes, which ? _____</td> <td style="text-align: center;">←</td> </tr> </table>		1. What substances have come into contact with the equipment ? Trade name and / or chemical term of service fluids and substances processed, properties of the substances According to safety data sheet (e.g. toxic, inflammable, corrosive, radioactive)		X	Tradename: _____	Chemical name: _____		a) _____	_____		b) _____	_____		c) _____	_____		d) _____	_____	2. Are these substances harmful ?		<table style="width:100%; border-collapse: collapse;"> <tr> <td style="width:50%; text-align: center;">No</td> <td style="width:50%; text-align: center;">Yes</td> </tr> <tr> <td style="text-align: center;"><input type="checkbox"/></td> <td style="text-align: center;"><input type="checkbox"/></td> </tr> </table>	No	Yes	<input type="checkbox"/>	<input type="checkbox"/>	3. Dangerous decomposition products when heated ?		<table style="width:100%; border-collapse: collapse;"> <tr> <td style="width:50%; text-align: center;">No</td> <td style="width:50%; text-align: center;">Yes</td> </tr> <tr> <td style="text-align: center;"><input type="checkbox"/></td> <td style="text-align: center;"><input type="checkbox"/></td> </tr> </table>	No	Yes	<input type="checkbox"/>	<input type="checkbox"/>	If yes, which ? _____		←																						
1. What substances have come into contact with the equipment ? Trade name and / or chemical term of service fluids and substances processed, properties of the substances According to safety data sheet (e.g. toxic, inflammable, corrosive, radioactive)																																																									
X	Tradename: _____	Chemical name: _____																																																							
	a) _____	_____																																																							
	b) _____	_____																																																							
	c) _____	_____																																																							
	d) _____	_____																																																							
2. Are these substances harmful ?		<table style="width:100%; border-collapse: collapse;"> <tr> <td style="width:50%; text-align: center;">No</td> <td style="width:50%; text-align: center;">Yes</td> </tr> <tr> <td style="text-align: center;"><input type="checkbox"/></td> <td style="text-align: center;"><input type="checkbox"/></td> </tr> </table>	No	Yes	<input type="checkbox"/>	<input type="checkbox"/>																																																			
No	Yes																																																								
<input type="checkbox"/>	<input type="checkbox"/>																																																								
3. Dangerous decomposition products when heated ?		<table style="width:100%; border-collapse: collapse;"> <tr> <td style="width:50%; text-align: center;">No</td> <td style="width:50%; text-align: center;">Yes</td> </tr> <tr> <td style="text-align: center;"><input type="checkbox"/></td> <td style="text-align: center;"><input type="checkbox"/></td> </tr> </table>	No	Yes	<input type="checkbox"/>	<input type="checkbox"/>																																																			
No	Yes																																																								
<input type="checkbox"/>	<input type="checkbox"/>																																																								
If yes, which ? _____		←																																																							
²⁾ Components contaminated by microbiological, explosive or radioactive products/substances will not be accepted without written evidence of decontamination.																																																									

D. Legally binding declaration

I / we hereby declare that the information supplied on this form is accurate and sufficient to judge any contamination level.

Name of authorized person (block letters) : _____

Date

signature of authorized person

firm stamp

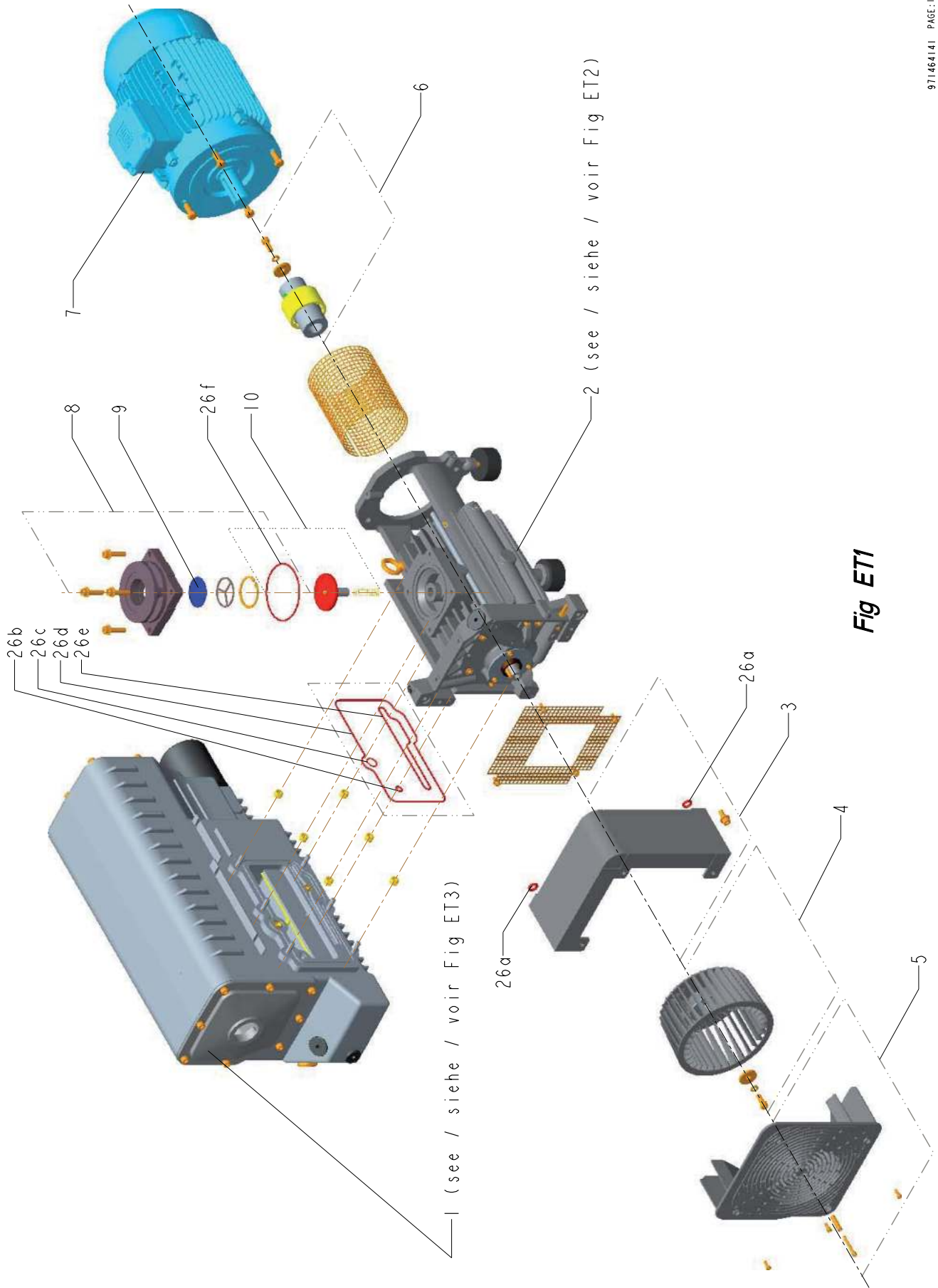

Fig ET1

Spare parts list

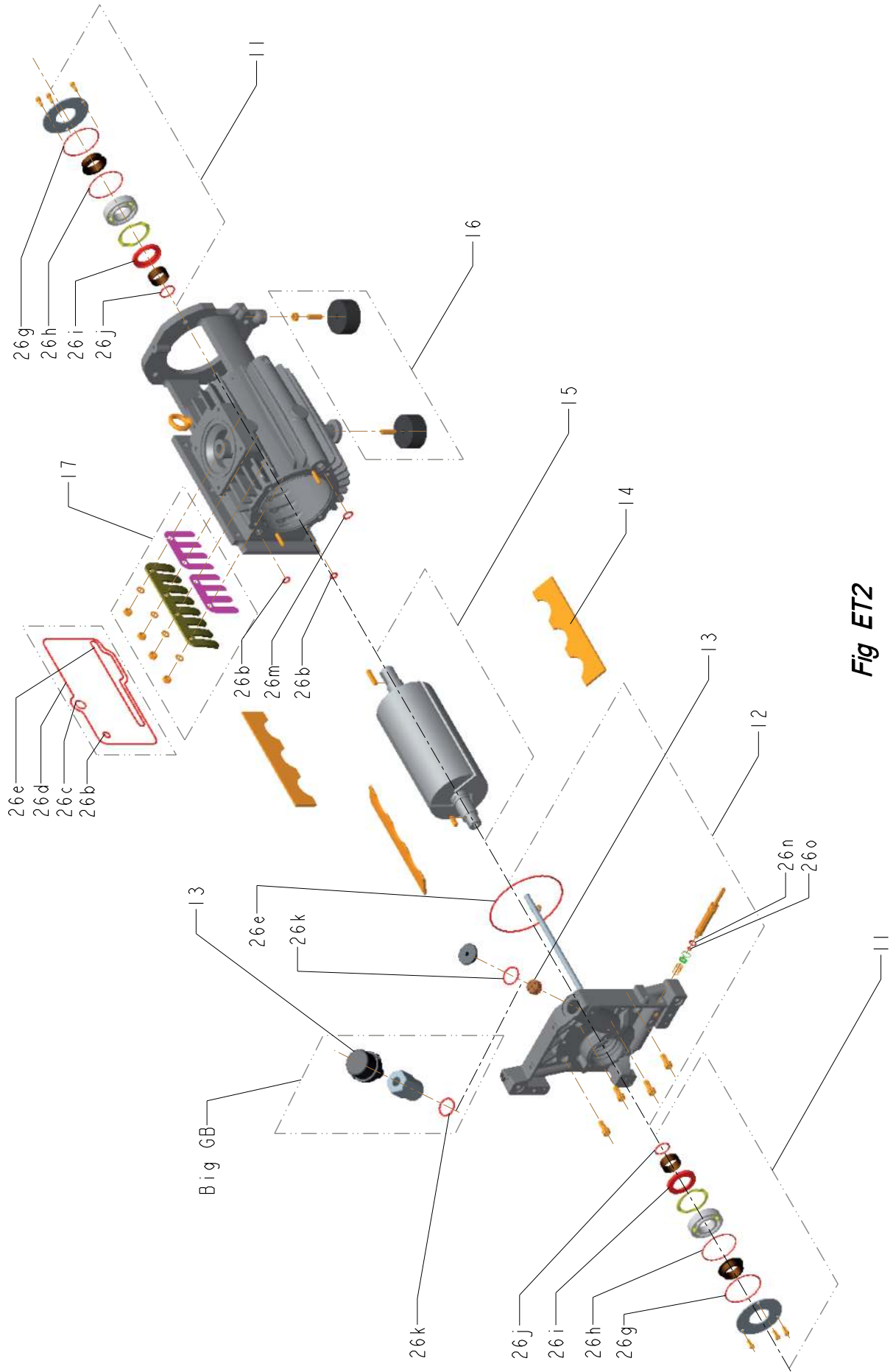

Fig ET2

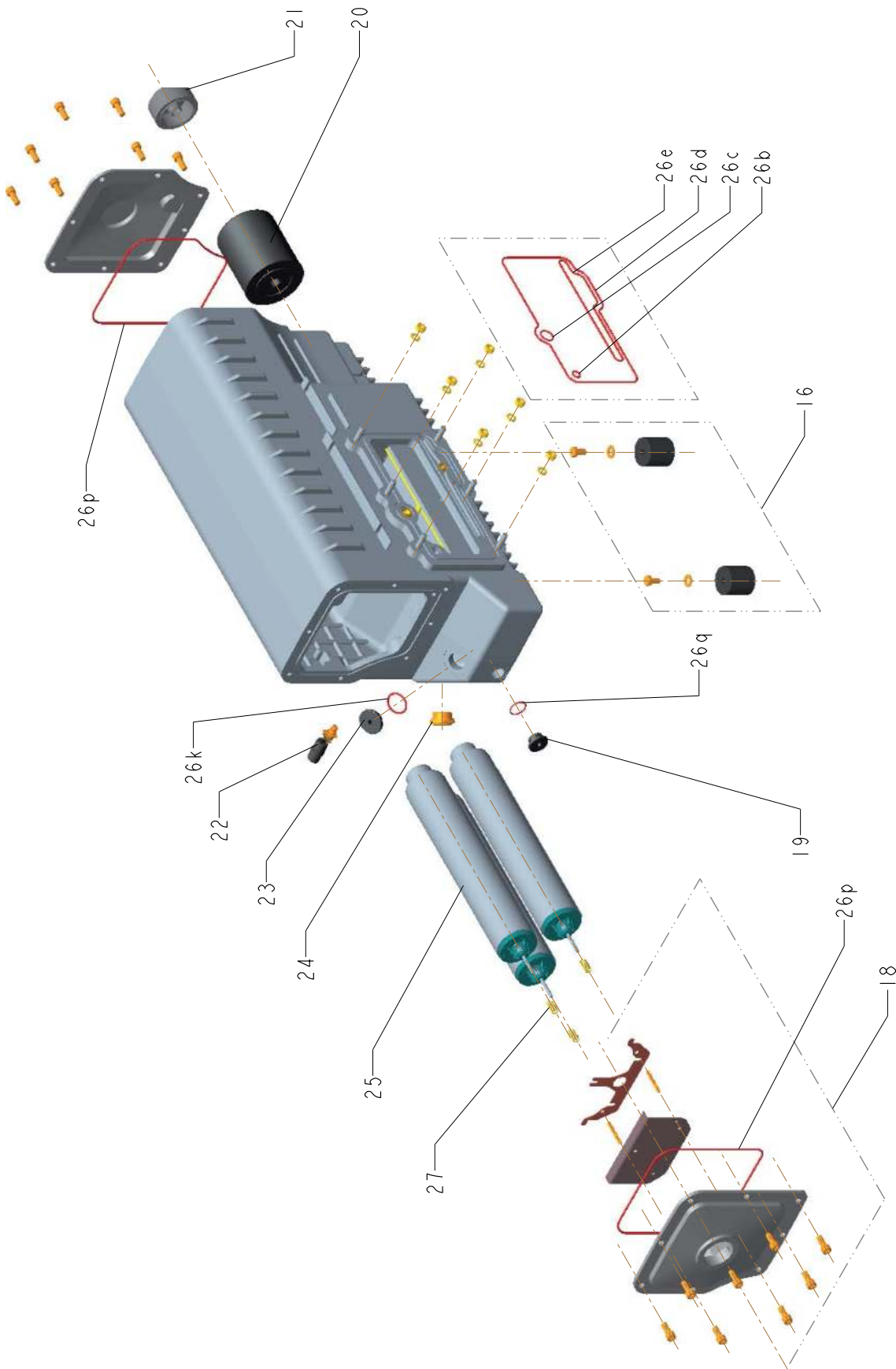

Fig ET3

Spare parts list

ERSATZTEILLISTE SV300 B / SPARE PARTS LIST SV300 B / LISTE DE PIECES DE RECHANGE SV 300 B

Pos. Item	Stück. Qty Qté	BENENNUNG	DESCRIPTION	DESIGNATION	Bestell-Nr. Part-Nr. N° de réf.	Bemerkungen Notes Remarques
1	1	ÖLKASTEN MIT ÖLFILTER G2"	OIL CASING WITH OIL FILTER G2"	CARTER AVEC FILTRE A HUILE EQ. G2"	971447620	Incl. 18, 19, 20, 22, 23, 24, 25, 26b, c, d, e, k, p, q, 27
2	1	VAKUUMGENERATOR EUR G2"	VACUUM GENERATOR EUR G2"	GENERATEUR ENS. EUR G2"	971447390	Incl. 11, 12, 13, 14, 15, 17, 26b, c, d, e, g, h, i, j, k, m, n, o
2	1	VAKUUMGENERATOR US NPT 2"	VACUUM GENERATOR US NPT 2"	GENERATEUR ENS. US NPT 2"	971458970	Incl. 11, 12, 13, 14, 15, 17, 26b, c, d, e, g, h, i, j, k, m, n, o
3	1	KÜHLER	RADIATOR	REFROIDISSEUR ENS.	971460700	Incl. 26a
4	1	TURBINE	TURBINE	TURBINE ENS.	971445920	
5	1	HAUBE	COVER	CAPOT ENS.	971460710	
6a	1	KUPPLUNG EUR IEC MOTOREN	COUPLING EUR IEC MOTORS	ACCOUPLLEMENT EUR MOTEURS CEI	971445970	
6b	1	KUPPLUNG US NEMA MOTOREN	COUPLING US NEMA MOTORS	ACCOUPLLEMENT US MOTEURS NEMA	971446030	
7a	1	MOTOR EUR IEC 230 / 400 V ± 10 %, 50 Hz 460 V ± 10 %, 60 Hz	MOTOR EUR IEC 230 / 400 V ± 10 %, 50 Hz 460 V ± 10 %, 60 Hz	MOTEUR EUR IEC 230 / 400 V ± 10 %, 50 Hz 460 V ± 10 %, 60 Hz	971457700	
7b	1	MOTOR JAPAN JIS 200 V ± 10 %, - 15 %, 50 & 60 Hz	MOTOR JAPAN JIS 200 V ± 10 %, - 15 %, 50 & 60 Hz	MOTEUR JAPON JIS 200 V ± 10 %, - 15 %, 50 & 60 Hz	971457710	
7c	1	MOTOR US NEMA 208 V ± 10 %, 230 / 460 V ± 10 %, 60 Hz 400 V ± 10 %, 50 Hz	MOTOR US NEMA 208 V ± 10 %, 230 / 460 V ± 10 %, 60 Hz 400 V ± 10 %, 50 Hz	MOTEUR US NEMA 208 V ± 10 %, 230 / 460 V ± 10 %, 60 Hz 400 V ± 10 %, 50 Hz	971458960	
7d	1	WELT-MOTOR 200V +10% -15%, 220-230-380-400-460V±10% 60HZ 200V +10% -15%, 220-230-380-400V±10% 50HZ	WIDE RANGE MOTOR 200V +10% -15%, 220-230-380-400-460V±10% 60HZ 200V +10% -15%, 220-230-380-400V±10% 50HZ	MOTEUR MULTI-TENSION 200V +10% -15%, 220-230-380-400-460V±10% 60HZ 200V +10% -15%, 220-230-380-400V±10% 50HZ	971466740	
8a	1	SAUGSTUTZEN EUR G2"	INTAKE FLANGE EUR G2"	BRIDE ASPI EUR ENS. G2"	971458900	Incl. 9, 26f
8b	1	SAUGSTUTZEN US NPT2"	INTAKE FLANGE US NPT2"	BRIDE ASPI US ENS. NPT2"	971460750	Incl. 9, 26f
9	1	SAUGSTUTZENFILTER	INTAKE FLANGE FILTER	FILTRE ASPIRATION	71213390	
10	1	SAUGSTUTZENVENTIL	ANTI-SUCKBACK VALVE	CLAPET ASPIRATION	971457690	Incl. 26f
11	1	LAGERKIT BEIDE SEITEN	BEARING KIT BOTH SIDES	PALIER ENS. 2 COTES	971464910	Incl. 26g, h, i, j
12	1	ENDPLATTENKIT	END PLATE KIT	FLASQUE ENS.	971446060	Incl. 13, 26a, b, e, k, m, n, o
13	1	GASBALLAST 3 DURCHFLÜSSE	GAS BALLAST 3 FLOWS	LEST AIR 3 DEBITS	971464130	Incl. 26k
14	1	SATZ VON 3 SCHIEBERN	SET OF 3 VANES	JEU DE 3 PALETTES	971446880	
15	1	ROTORKIT	ROTOR KIT	ROTOR ENS.	971445930	
16	1	GUMMIFUSSKIT	RUBBER FEET KIT	AMORTISSEUR ENS.	971464930	
17	1	VENTILPLATTE UND ANSCHLAG KIT	VALVE AND VALVE STOP KIT	LAME ET CONTRE LAME	971464940	
18	1	AUSLASSKIT	EXHAUST PLATE KIT	KIT BRIDE REFOULEMENT	971458930	Incl. 26p
19	1	ÖLABLASSKIT	OIL DRAIN PLUG G3/4"	BOUCHON VIDANGE G3/4"	71256380	Incl. 26q
20	1	ÖLFILTER	OIL FILTER	FILTRE A HUILE	71018850	
21	1	ÖLFILTER BYPASS	OIL FILTER BYPASS	BY PASS FILTRE A HUILE	71230570	
22	1	SCHWIMMERTVENTIL KIT	FLOAT VALVE KIT	FLOTTEUR ENS.	71417210	
23	1	ÖLFULLSTOPFEN G1"	OIL FILL PLUG G1"	BOUCHON REMPLISSAGE G1"	71073040	Incl. 26k
24	1	GLASS ÖLSCHAUGLASS	GLASS OIL SIGHT GLASS	VOYANT HUILE VERRE	971460230	
25	3	AUSLASSFILTER MIT BYPASS	EXHAUST FILTER WITH BYPASS	CARTOUCHE REFOUL. AVEC BY-PASS	971431120	
27	3	DRUCKFEDER	COMPRESSION SPRING	RESSORT DE COMPRESSION	71436210	
28	1	DICHTUNGS-KIT FPM	SEAL KIT FKM	JEU DE JOINTS FKM	971464950	All items 26
	1	REPARATUR-KIT	REPAIR KIT	KIT DE REPARATION	971464960	Incl. 6, 11, 14, 17, 20, 24, 25, 26, 27
	1	WARTUNGS-KIT	MAINTENANCE KIT	KIT DE MAINTENANCE	971464970	Incl. 19, 23, 25, 26k, p, q, 27