

Vacuum Solutions

Application Support

Service

GA02411_0502

Chemtech Scientific provides access to this content as a courtesy.
We do not own the content contained in this document.
All rights and credit go directly to its rightful owners.
www.chemtechsci.com
Call us at: 484-424-9415



ScrewLine ***SP 630 / SP 630 F***

Dry Compressing
Vacuum Pump

P/N

117 001
117 002
117 105
117 106

Operating Instructions

Contents

Important Safety Information4

1 Description6

1.1 Area of Application6

1.2 Principle6

1.2.1 Design6

1.2.2 Principle of Operation8

1.3 Technical Data9

1.3.1 Available Documentation10

1.4 Supplied Equipment11

1.5 Pump Versions11

1.6 Accessories12

1.7 Spare Parts12

1.8 Storing12

2 Operation13

2.1 Placement13

2.1.1 Transportation13

2.1.2 Floor13

2.1.3 Air Cooling and Pump Covers14

2.1.4 Ambient Conditions14

2.1.5 Installation Location14

2.2 Connection to the System15

2.2.1 Connections at the Intake Side15

2.2.2 Connections at the Delivery Side (Exhaust)16

2.3 Electrical Connection16

2.3.1 Motor Protection17

2.3.2 Soft Start19

2.3.3 Mains Connection20

2.3.4 Power Failure20

2.3.5 Frequency Converter20

2.4 Start-Up22

2.4.1 Oil Filling for the Gear22

2.4.2 Switching the Pump On24

2.4.3 Oil Temperature25

2.4.4 Regular Checks25

2.5 Operating Conditions26

2.6 Switching Off / Shutting Down26

2.7 Emergency Shutdown26

2.8 Pump Monitoring27

2.8.1 Oil Temperature Sensor PT 10027

3 Maintenance28

3.1 Checking the Oil Level28

3.1.1 Oil Change and Oil Filter Change28

3.2 Cleaning the Oil Cooler29

3.3 Draining Out Condensate (optional)30

3.4 Cleaning the Dust Filter (optional)30

3.5 Leybold Service30

3.6 Table/Maintenance and Service Work31

4 ScrewLine SP 630 F - Water Cooled32

4.1 Technical Data32

4.2 Water Quality32

4.3 Connecting the Cooling Water33

4.4 Oil Temperature34

4.5 Maintenance on the Water Filter34

4.6 Maintenance on the Heat Exchanger35

4.7 Transportation and Maintaining in Stock35

4.8 Table/Maintenance and Servicing Work36

5 Troubleshooting37

EC Declaration of Conformity38

Declaration of Contamination of Compressors, Vacuum Pumps and Components40

Warning  These Operating Instructions apply to standard products only. If the pumps which have been delivered are of a custom design, then the delivery will include additional instructions which are part of the Operating Instructions.

We reserve the right to modify the design and the specified data. The illustrations are not binding.



We strongly recommend that you read these Operating Instructions with care before installing and starting up the vacuum pump so as to ensure optimum operation of the vacuum pump right from the start.

Note

The ScrewLine vacuum pumps have been manufactured to the latest engineering standards and approved safety regulations. Even so when not properly installed or when not used and operated as intended the pump may be a source of danger and can cause damage.

Warning



Indicates procedures that must be strictly observed to prevent hazards to persons.

Caution

Indicates procedures that must strictly be observed to prevent damage to, or destruction of the vacuum pump.

Figures

The references to diagrams, e.g. (1/2) consist of the Fig. No. and the Item No. in that order.

Disposal of Waste Oil

Owners of waste oil are entirely self-responsible for proper disposal of this waste.

Waste oil from vacuum pumps must not be mixed with other substances or materials.

Waste oil from vacuum pumps which is subject to normal wear and which is contaminated due to the influence of oxygen in the air, high temperatures or mechanical wear must be disposed of through the locally available waste oil disposal system.

Waste oil from vacuum pumps which is contaminated with other substances must be marked and stored in such a way that the type of contamination is apparent. This waste must be disposed of as special waste.

European, national and regional regulations concerning waste disposal need to be observed. Waste must only be transported and disposed of by an approved waste disposal vendor.

Leybold Service

Before opening the pump chamber during maintenance work (for cleaning, for example) by LV staff, the Declaration of Contamination must be filled-in by the customer first. This is needed to protect our staff.

If a vacuum pump is returned for repair to Leybold indicate whether the pump is free of substances damaging to health or whether it is contaminated.

If the vacuum pump is contaminated also indicate the nature of the hazard. Leybold must return any vacuum pumps received without accompanying "Declaration of Contamination" to the sender.

A sample of this Declaration of Contamination has been enclosed at the end of these Operating Instructions.

This Declaration of Contamination is required to comply with legal rulings and to protect our staff (see also Chapter 3.5 "Leybold Service").

IMPORTANT SAFETY INFORMATION

The ScrewLine must only be operated in the proper state and in the state described in the Operating Instructions. The dry compressing ScrewLine vacuum pump from Leybold will ensure, when used properly and in line with the information provided in these Operating Instructions, a safe and proper service. Please take some time to read all safety notes given in this chapter and the other chapters of these Operating Instructions, and make sure that these are complied with. The vacuum pump must only be operated, and any maintenance must be done only by trained staff. Please also note any special requirements and regulations which may apply at your location or which are demanded by law. In case you have any questions relating to safety, operation and/or maintenance of the vacuum pump please contact your nearest Leybold Vacuum sales office.

Warning

Non-compliance with the safety information given in the following can result in severe injury:



- Never operate the ScrewLine pump with an opened pump chamber or fan housing. There is the risk of suffering injury.



- The standard ScrewLine pump is **not** suited for pumping of:
 - combustible or explosive gases and vapours
 - radioactive and toxic substances
 - Gas mixtures with an oxygen share of > 21%
 - pyrophorous substancesWhen planning such an application please contact us first.



- The ScrewLine has **not** been designed for operation in explosion hazard areas. When planning such an application please contact us first.
- Before operating the ScrewLine with gas ballast (optional), compatibility of the gas ballast with the media being pumped must be checked first, so as to avoid dangerous conditions.
- Before starting the ScrewLine up, check the substances which are to be pumped for compatibility so as to avoid dangerous conditions. All relevant safety standards and regulations must be observed.
- In the exhaust line the pressure must not be allowed to increase over 1,200 mbar abs. This applies also when the pumped out gases need to be contained.
- Make sure that the gas flow at the exhaust is not blocked or restricted in any way.
- The electric motor must be protected by suitable means against being overloaded. For this note the information given in these Operating Instructions.
- The ScrewLine must be integrated with the system controller such that the pump can not run up automatically when the pump has been shut down before due to an overloaded motor. This equally applies to any emergency shutdowns. After having removed the fault cause, the pump must be switched on manually again.
- The location for the ScrewLine (including accessories) should, as a rule, be such that angles exceeding 10 degrees from the vertical are avoided. When tilting the ScrewLine by more than 10 degrees from the vertical, there is the risk that the pump may topple over.
- Avoid exposing any part of the human body to the vacuum.
- Never operate the ScrewLine without having connected the intake line or fitted a blank flange first.
- The noise level produced by the ScrewLine is given in the Chapter "Technical Data". Suitable hearing protection measures must be introduced.
- Before starting with any maintenance or servicing work reliably disconnect the ScrewLine from all sources of power.

- Before starting with any maintenance or servicing work make sure that no gas can flow backwards through the ScrewLine, since this might cause the rotors to turn. For this reason always vent the vacuum chamber to exhaust pressure or ensure, by installing suitable valves, that the vacuum chamber and the lines will be separated reliably from the pump.
- Select the location where the ScrewLine is installed so that all controls can be easily accessed.
- It is recommended always to operate the ScrewLine with a connected and suitable exhaust line.
- For transporting the ScrewLine use only approved means of transport. One crane eye is provided on the pump as standard.

Caution **Non-compliance with the following precautions can result in damage to the pump:**

- Make sure that no small parts (bolts, nuts, washers, pieces of wire etc.) enter into the pump. For this reason always fit the inlet screen provided with each pump.
- When connecting the pump to a vacuum chamber, a suitable valve (electric blocking valve, for example) needs to be provided for interrupting the intake line so as to prevent the pump from running backwards in the event of a power failure. Otherwise the pump may suffer damage.
- The pump must always only be operated with a closed fan housing (swivelling oil cooler) and with all covers in place so as to ensure sufficient cooling of the pump.
- The pump must only be operated at the specified frequency.
- Before pumping condensable vapours the ScrewLine should have attained its operating temperature. If an optional gas ballast is present, it should be used. The pump will attain its operating temperature about 30 minutes after switching on. During this time, the pump should be separated from the process, by a valve in the intake line, for example.
- If condensable gases are pumped by the ScrewLine, the pump should be purged for about 15 minutes with an inert gas or air (depending on the application in each case) before switching the pump off. This should also be done before cleaning the pump chamber.
- Do not clean a pump which is still warm with water, since the cooling shock can severely damage the pump.
- In the case of such applications which involve larger amounts of condensate, the use of a condensate separator in the exhaust line is strongly recommended.
- The exhaust line should be laid so that it slopes down and away from the pump so as to avoid a back flow of condensed vapours into the pump.
- In order to avoid the transfer of vibrations from the ScrewLine pump to other connected pieces of equipment, we recommend fitting of corrugated hoses or compensators at the intake and the exhaust sides.
- Before transporting the ScrewLine SP 630, the gear oil must be drained out.

Notes **The following notes serve the purpose of utilising the pump to the best effect:**

- Lines and other vacuum connections should be clean and free of oil. This must be observed especially when having used oil-sealed pumps before. The state must be checked before commissioning; in the case of deviations any oil which may still be present can contaminate the pump with oil residues.
- The pressure in a pump which has been switched off will rise to the ambient pressure within a few seconds. In such a case the pump is vented backwards through the exhaust.

1 Description

1.1 Area of Application

The ScrewLine has been developed specifically for the special requirements of industrial applications.

Typical areas of application are: industrial furnaces, metallurgical systems etc.

The standard ScrewLine vacuum pumps have been designed to pump air or inert gases in the pressure range between atmospheric pressure and the ultimate pressure of the pump. If other gases are to be pumped with this pump, please consult Leybold first.

Note If variants are operated with the SP-Guard also the information given in Operating Instructions GA 02.495 must be observed.

Warning  The standard versions of the ScrewLine pump are not suited for pumping any toxic, caustic, combustible and/or explosive gas mixtures.

If such gas mixtures should be present in your application please consult Leybold first.

If gases are to be pumped which in contact with air will form explosive mixtures please consult Leybold for advice about suitable protection means.

The ScrewLine pumps must not be operated in explosion hazard and/or areas in which combustible materials are present.

If in doubt contact Leybold for advice.

Gas mixtures with an oxygen share of > 21 percent by volume must not be pumped. If such gas mixtures are to be pumped, please contact LV first.

Caution The pumps have not been designed to pump liquids. Suitable protection means must be introduced. If in doubt contact Leybold for more information.

Each application has its special requirements. Your contact at Leybold will be pleased to inform you about the specific uses of the ScrewLine pump in each case.

1.2 Principle

1.2.1 Design

The ScrewLine SP 630 is a dry compressing screw-type vacuum pump capable of a maximum pumping speed of $630 \text{ m}^3 \cdot \text{h}^{-1}$.

It has been developed specifically for the special requirements of industrial applications. For this reason the ruggedness of the pump was a main design criterion.

The screw shaped rotors are fitted to two horizontally arranged shafts and revolve without making contact within the pump chamber. The shafts are synchronised by a toothed gear. The shafts are driven via a further gear stage by an electric motor.

In vacuum pumps, the seals and the bearings on the vacuum side are always a potential source for a breakdown.

On the one hand lubricants may enter from the bearing into the vacuum process and on the other hand aggressive process media can endanger the bearings.

These disadvantages are avoided by the "cantilevered" arrangement of the rotors. The ScrewLine is equipped with two cantilevered screw type rotors which are guided by oversized shafts and bearings. The bearings are located both in the gear chamber of the pump.

A further advantage of the cantilevered arrangement is that the pump chamber is easily accessible without having to disassemble any bearings. Thus any possibly required cleaning operations necessary due to the influence of the process can be run easily.

The cantilevered rotors minimise the risk of bearing damage and also reduce on-site maintenance to a minimum.

Shaft seals are in the case of the ScrewLine pump only required on the delivery side of the rotors. Owing to the small pressure difference between exhaust and gear, simple and reliable seals can be provided. The two shaft seals consist of a combination of a piston ring and a labyrinth seal thus making almost no contact so that the seals will be almost free of wear.

In standard applications no barrier gas will be required at the seals. However, if demanded by the process conditions, a barrier gas may be supplied to the seals.

The ScrewLine is air-cooled. A radial fan supports the cooling effect for the casing which is equipped liberally with cooling fins.

Depending on requirements, the ScrewLine pumps may be combined with Roots pumps so as to attain higher pumping speeds at lower pressures.

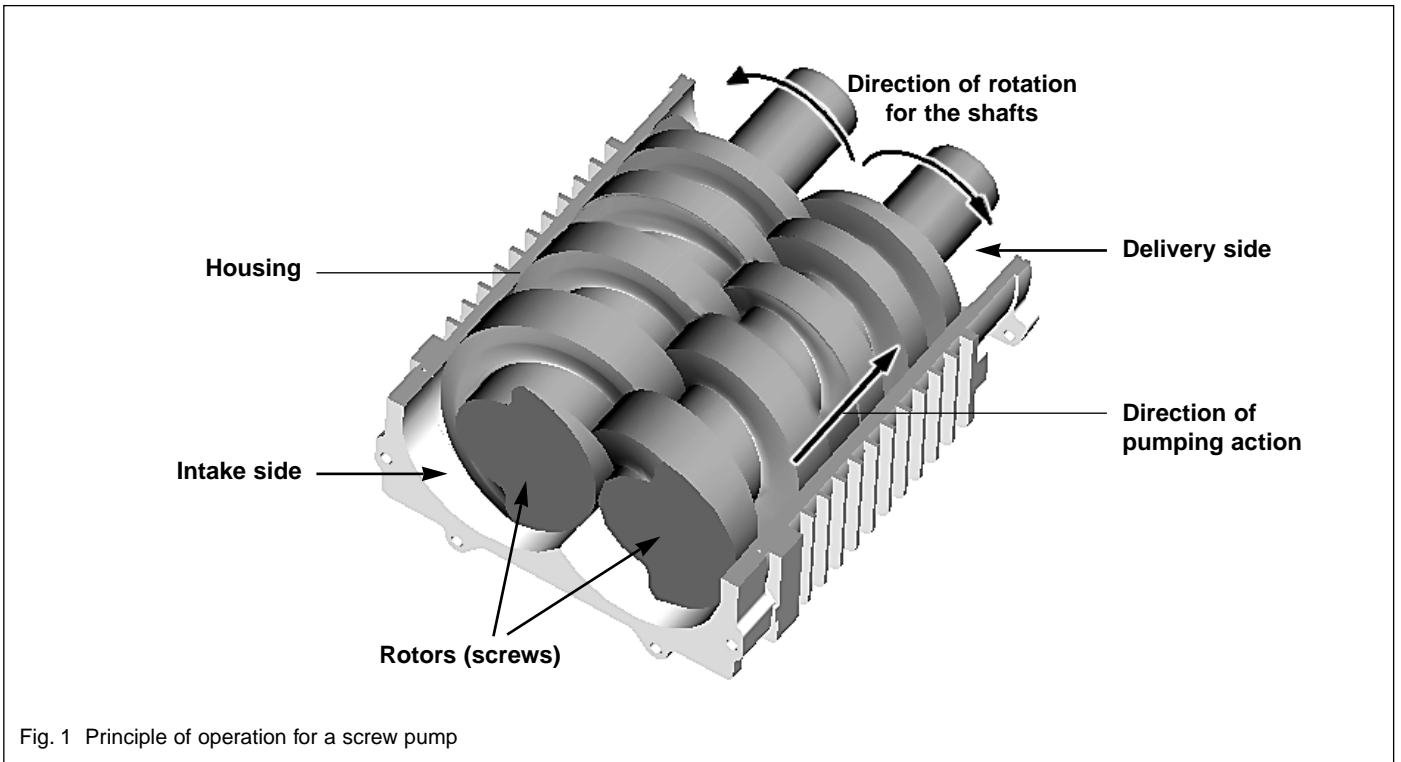

Fig. 1 Principle of operation for a screw pump

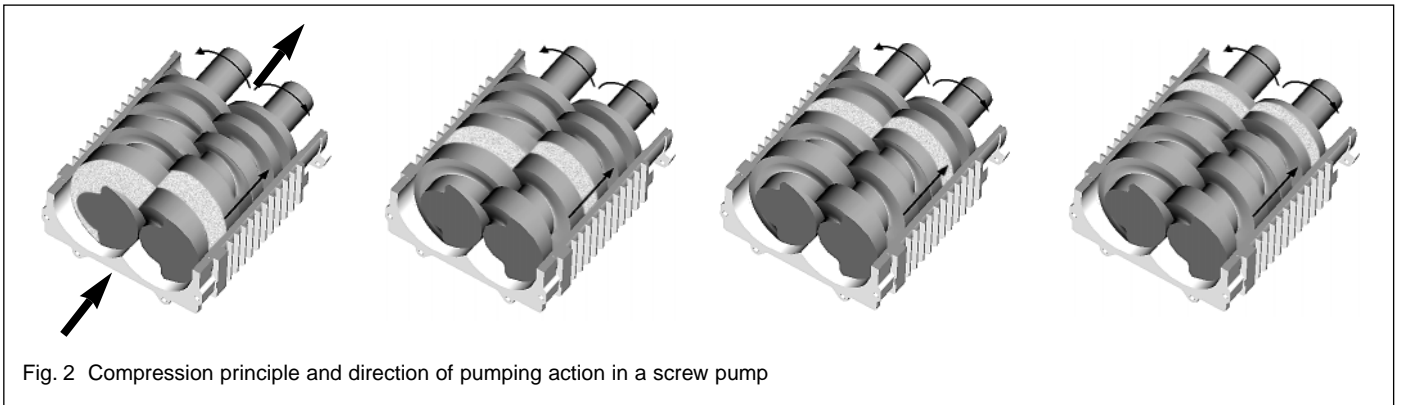

Fig. 2 Compression principle and direction of pumping action in a screw pump

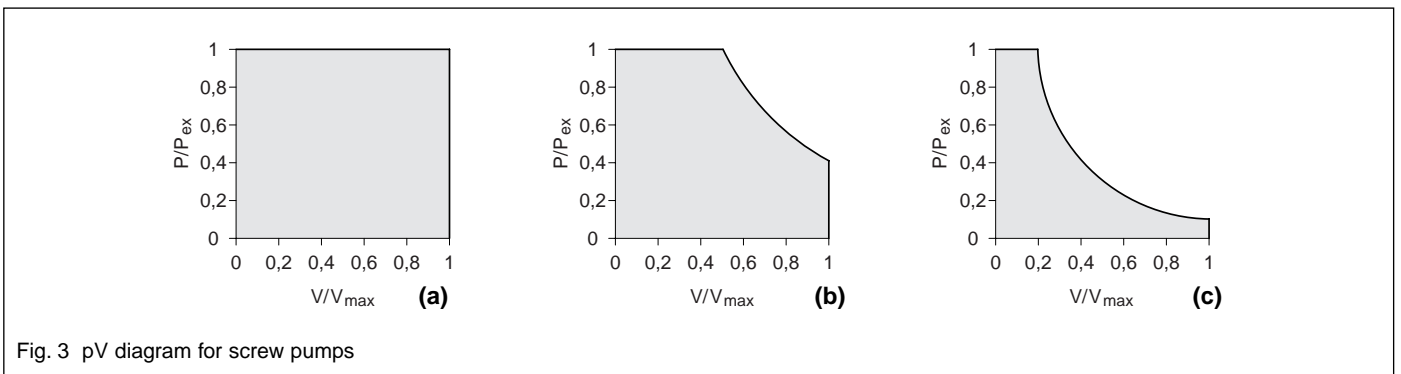

Fig. 3 pV diagram for screw pumps

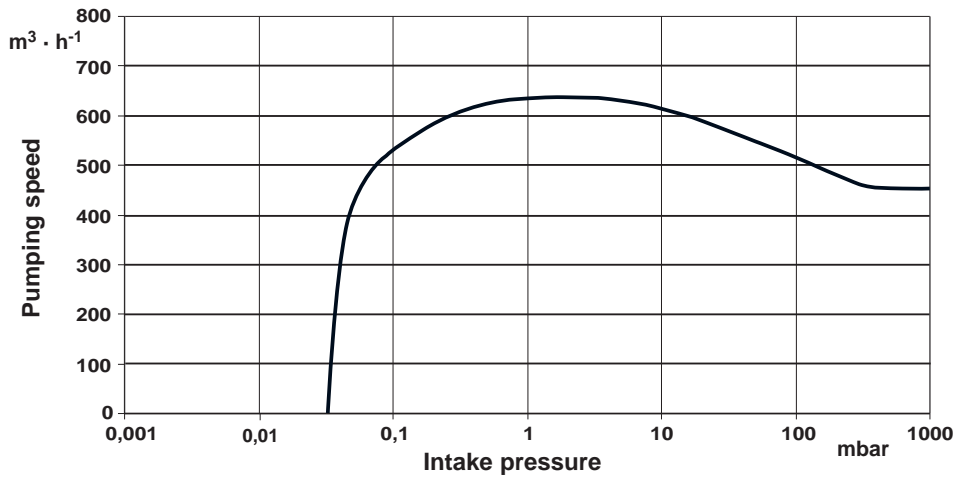

Fig. 4 Pumping speed curve for the ScrewLine SP 630/SP 630 F at 50 and 60 Hz

1.2.2 Principle of Operation

In the ScrewLine vacuum pumps the pump chamber is formed by two synchronised displacing rotors and the housing.

A pair of tightly intermeshing right-handed and left-handed threads is used to implement with only very few components a large number of stages and thus very low ultimate pressures.

Figures 1 and 2 show how by the two rotors and the housing several chambers are created which allow the gas to be compressed. Since the rotors turn in opposing directions, the chambers “move” steadily from the intake to the delivery side of the pump (Fig. 2) so that the gas is conveyed in a low-pulsation manner.

The continuous pumping action for the gas without the need of having to deflect the gas will also allow pumping of particles entrained in the gas and also vapours to a limited extent.

As in the case of other dry compressing (slot sealed) vacuum pumps, also in the case of screw pumps very tight slots need to be maintained between the components. Otherwise the leaks caused by the pressure drop would have a negative effect on both pumping speed and attainable ultimate pressure. Moreover, the pump might heat itself up too much due to unfavourable thermodynamic processes.

During operation the design of the ScrewLine ensures that the slots are maintained within the operational limits of the pump. In order to limit the temperatures attained by the components, the housing of the pump chamber is air-cooled. Also the rotors themselves are cooled: by oil which is pumped through bores in the rotor shafts and which also lubricates the bearings and the toothed wheels of the pump’s synchronising gear.

Thus an even temperature spread is attained within the pump. The amount of “inner compression” has a significant influence on the temperature level within a vacuum pump. In the case of a foreline pump, most of the work on compression is done while the gas is being ejected against the delivery pressure, i.e. in the last stages of the pump. For this reason in the case of the ScrewLine the volume of the gas is already significantly reduced at pressures which are as low as possible so as to minimise this work done on compression. In this way the power requirement of the pump is reduced and less heat needs to be dissipated.

Fig. 3 shows the pV diagram of screw pumps: (a) without inner compression, (b) with inner compression against the face side of the pump chamber and (c) by reducing the chamber volume along the rotor. The surface areas enclosed in the pV diagram are in each case proportional to the power uptake of the pump. It is apparent that the most efficient method is to compress the gas which is to be pumped by reducing the axial pitch of the rotor from the inlet to the delivery side (Fig. 2) so that the chamber volume is already reduced at low pressures (Fig. 3c). In this way a power consumption can be attained which is comparable to that of rotary vane pumps.

1.3 Technical Data

(As to deviating technical data for the water cooled version, see Chapter 4.1)

(For supplied versions, see Chapter. 1.5)

| ScrewLine | SP 630 (50 Hz) | SP 630 (60 Hz) | |
|--|---|-----------------------|---|
| Type | dry compressing screw vacuum pump | | |
| Max. pumping speed ($\pm 10\%$) | $\text{m}^3 \cdot \text{h}^{-1}$ | 630 | |
| Ultimate pressure, total | mbar | ≤ 0.03 | |
| Permissible exhaust back pressure | mbar | 800 - 1200 | |
| Max. permissible intake pressure | mbar | 1030 | |
| Noise level ¹⁾ | dB (A) | ≤ 75 | |
| Total weight, approx. | kg | 530 | |
| Dimensions (L x W x H) | mm | 1630 x 660 x 880 | |
| Permissible ambient temperatures | $^{\circ}\text{C}$ | 10 to 40 | |
| Contamination grade ²⁾ | | 3 | |
| Water vapour tolerance (with gas ballast) | mbar | 40 | |
| Relative humidity of the air ³⁾ | % | max. 95 | |
| Installation location | 0 - 3000 m (above sea level) | | |
| Maximum exhaust pressure relative to ambient pressure | $p_{\text{ex}} = p_{\text{amb}} \pm 200 \text{ mbar}$ | | |
| Motor | | | |
| Speed (50 / 60 Hz) | rpm | 2930 | 3530 |
| Nominal power rating (50 / 60 Hz) | kW | 15 | |
| Nominal current at operating voltage and 50 Hz, $\Delta\Delta$ | 56 A / 200 V (190 - 210 V $\pm 5\%$) | | |
| Nominal current at operating voltage and 50 Hz, Δ | 28 A / 400 V (380 - 420 V $\pm 5\%$) | | |
| Nominal current at operating voltage and 60 Hz, $\Delta\Delta$ | 52 A / 210 V (190 - 240 V $\pm 5\%$) | | |
| Nominal current at operating voltage and 60 Hz, Δ | 24 A / 460 V (380 - 480 V $\pm 5\%$) | | |
| $\cos \varphi$ | 0.89 | | 0.90 |
| Type of motor protection | IP 55 | | |
| Heat protection class | F | | |
| Flanges | | | |
| Intake and exhaust flange compatible with | DN 100 / PN 6 (EN 1092-2) DN 100 / PN 10 (EN 1092-2) NPS 4" Class 150 (acc. to ASME B 16.5-1996) "DN 100 ISO-K"(in accordance with ISO 1609-1986 (E)) -this collar flange is required, when ISO-K flanges are to be connected (P/N 267 50) | | |
| Operating agents | | | |
| Cooling | Air Water, see Chapter 4 | | |
| Cooling water temperature | 5 - 35 $^{\circ}\text{C}$ | | |
| Approved type of oil: Anderol 555 | I | 15 | |
| Materials (components in contact with the gas) | | | aluminium, aluminium anodic coating, C steel, CrNi steel, grey cast iron, FPM |

¹⁾ with blanked off lines at ultimate pressure, in accordance with ISO 4871

²⁾ in accordance with EN 50178

³⁾ in accordance with EN 60721-3-3

Description

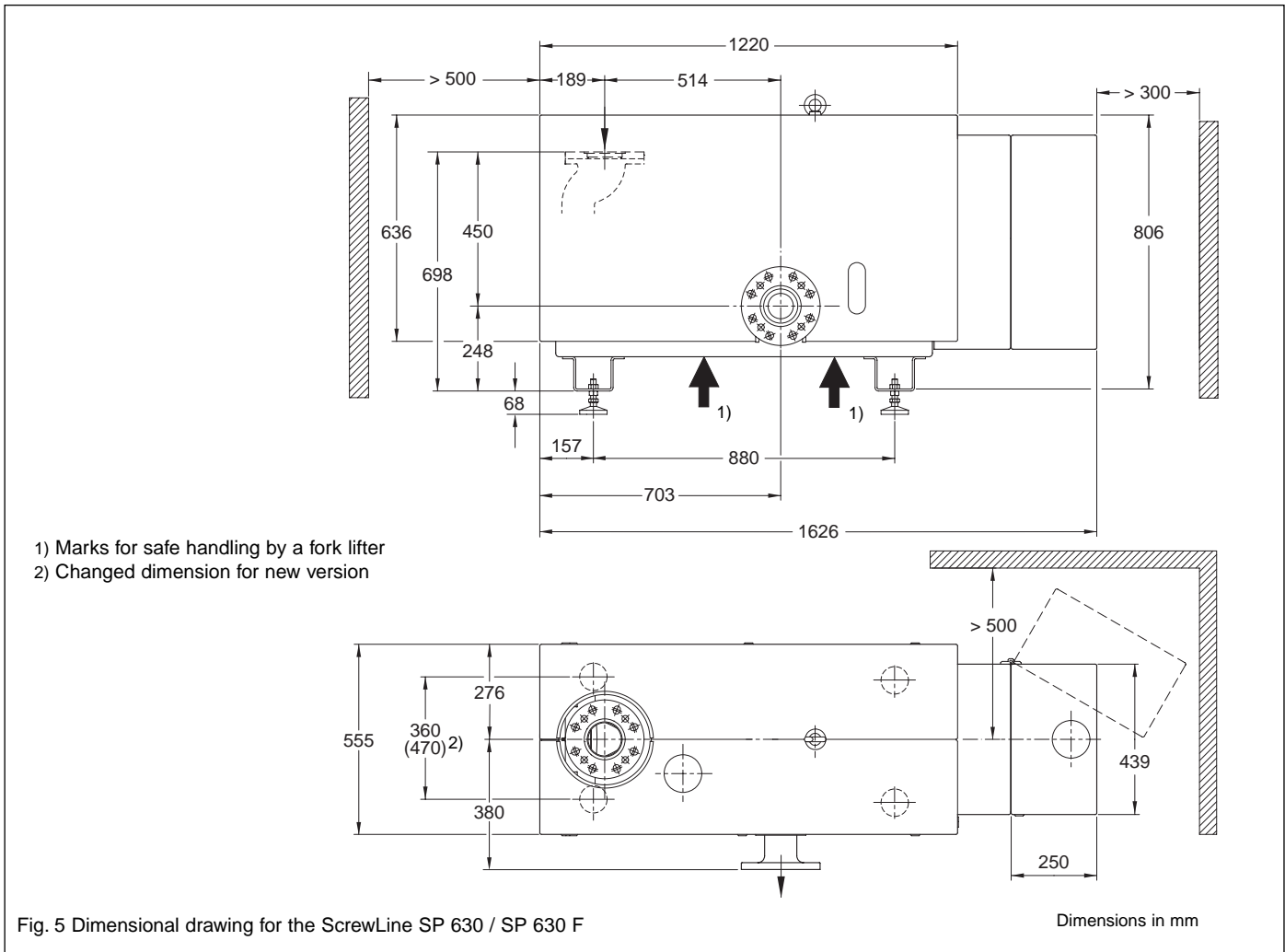

1.3.1 Available Documentation

| | GA02411 | KA02493 | KA02491 | GA02495 | KA02492 | KA02494 | KA02490 |
|---------|---|------------------------|---------------------------------|----------|-----------------------|----------|---------------------|
| | ScrewLine SP 630 / 630 F 50/60 Hz | Gas ballast, manual | Gas ballast, electromagnetic | SP-Guard | Adapter RUVAC 2001 | Silencer | Non-return Valve |
| P/N | | | | | | | |
| 117 001 | x | | | | | | |
| 117 002 | x | | | | | | |
| 117 003 | x | | | x | | | |
| 117 004 | x | | | x | | | |
| 117 005 | x | | x | x | x | | |
| 117 006 | x | | x | x | x | | |
| 117 007 | x | x | | x | | | |
| 117 008 | x | x | | x | | | |
| 117 009 | x | | x | x | | | |
| 117 010 | x | | x | x | | | |
| 117 011 | x | x | | x | x | | |
| 117 012 | x | x | | x | x | | |
| 117 105 | x | | x | x | x | | |
| 117 106 | x | | x | x | x | | |
| 119 001 | | | | | | x | |
| 119 010 | | | | | | | x |

1.4 Supplied Equipment

The ScrewLine is supplied ready for installation and connection.

The ScrewLine pump is delivered with:

- An integrated 15 kW motor.
- The required amount of gear oil (is supplied separately).
- A Pt 100 sensor for monitoring the oil's temperature. This sensor needs to be connected by the customer.
- An inlet screen preventing the ingress of small objects into the inlet of the pump.
- 1 crane eye for transporting the pump.
- 2 cable fittings for the junction box.
- Square key for disassembly/assembly of the cover and for opening the fan housing.
- Operating Instructions

Intake and exhaust ports are sealed with foil. Remove this foil and also the dessicant inside before switching on the pump.

Note For the purpose of shipping the pump, the pump has been affixed to a special pallet. Retain this pallet in case the pump needs to be returned.

The electrical connections to the pump must be provided by suitably trained staff of the customer (see Chapter 2.3 Electrical Connection).

1.5 Pump Versions

The following pump versions are available:

- Pump for 50 Hz operation - **P/N 117 001**
- Pump for 60 Hz operation - **P/N 117 002**
- Version for 50 Hz operation with SP-Guard - **P/N 117 003**
- Version for 60 Hz operation with SP-Guard - **P/N 117 004**
- Version for 50 Hz operation with adapter for RUVAC 2001 with SP-Guard and electromagnetic gas ballast - **P/N 117 005**
- Version for 60 Hz operation with adapter for RUVAC 2001 and SP-Guard and electromagnetic gas ballast - **P/N 117 006**
- Version for 50 Hz operation with SP-Guard and manual gas ballast - **P/N 117 007**
- Version for 60 Hz operation with SP-Guard and manual gas ballast - **P/N 117 008**
- Version for 50 Hz operation with SP-Guard and electromagnetic gas ballast - **P/N 117 009**
- Version for 60 Hz operation with SP-Guard and electromagnetic gas ballast - **P/N 117 010**
- Version for 50 Hz operation with SP-Guard, manual gas ballast and RUVAC 2001 adapter - **P/N 117 011**
- Version for 60 Hz operation with SP-Guard, manual gas ballast and RUVAC 2001 adapter - **P/N 117 012**
- Version for 50 Hz operation water cooled, with adapter for RUVAC 2001, with SP-Guard and electromagnetic gas ballast - **P/N 117 105**
- Version for 60 Hz operation water cooled, with adapter for RUVAC 2001, with SP-Guard and electromagnetic gas ballast - **P/N 117 106**

1.6 Accessories

- | | P/N |
|---|---------|
| • Exhaust silencer with condensate drain | 119 001 |
| For this please note the Brief Instructions - KA 02.494 | |
| • Non-return valve | 119 010 |
| For this, please note of the Brief Instructions - KA02490 | |
| • Roots pump adapter for RUVAC 2001 | 119 021 |
| For this please note the Brief Instructions - KA 02.492 | |
| • Gas ballast valve, manually operated | 119 051 |
| For this please note the Brief Instructions - KA02493 | |
| • Solenoid gas ballast valve | 119 052 |
| For this please note the Brief Instructions - KA02491 | |
| • Dust filter | .951 72 |
| • Adapter (universal flange DN 100 ISO-K) . . . | 119 020 |
| (may be used to connect a dust filter, a valve or universally) | |

Stability of the pump when using LEYBOLD accessories is ensured. If other accessories are fitted then the user himself will be responsible for maintaining stability of the pump.

1.7 Spare Parts

- Maintenance kit level 1, SP 630 for gear oil change, 15 l ANDEROL 555, oil filter cartridge and 2 gasketsEK110000792
- Maintenance kit level 2, SP 630
2 O-rings, inlet screen, including O ringsEK110000793
- Maintenance kit level 3, SP 630
2 O-rings, 6 gaskets (Cu), 2 angular ball bearingsEK110000794

Additional spare parts are available from the Leybold service offices.

1.8 Storing

When shelving the pump for a longer period of time, the oil should be drained out. Before sealing off the flanges of the pump with foil, a bag with desiccant should be placed in the exhaust flange and the intake flange.

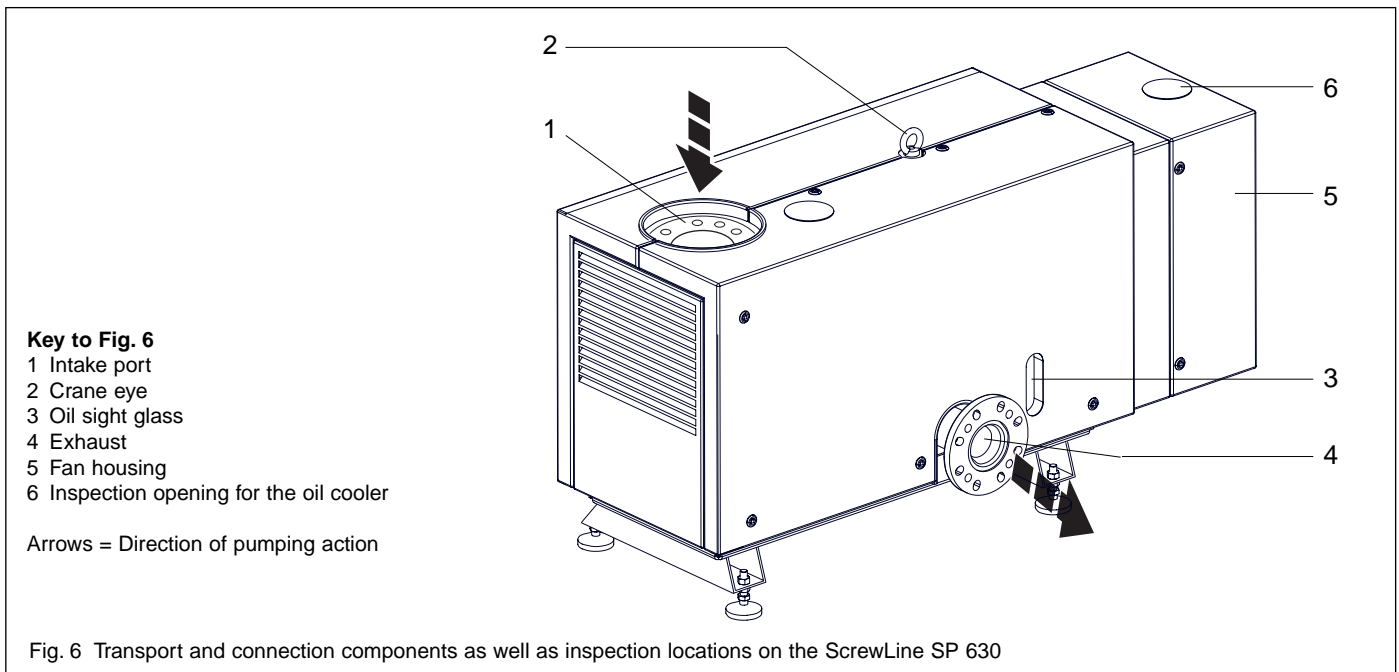

2 Operation

2.1 Placement

Warning The standard pump is not suited for being installed in explosion hazard areas. Please contact us first when planning such an application. Before installing the pump it must be disconnected from all sources of electrical power and protected against being switched on inadvertently. Only trained staff may install the pump. Please observe the safety regulations.



Caution The pump's frame has been designed for handling with a fork lifter. The points under which the forks must engage are indicated in Fig. 5.

Warning The pump can only be transported safely at these points, otherwise there is the risk that the pump may topple.



For transporting, the silencer must be disassembled as otherwise there is the risk of toppling.

2.1.1 Transportation

Warning When transporting the ScrewLine pump please note its total weight first (see Chapter 1.3 Technical Data). Use only approved means to transport the pump. The transport means must be so rated that they can adequately handle the weight of the pump. Located on the top side is as standard a crane eye (Fig. 6 item 2,) in accordance with DIN 580 C15VZ M 16. The crane hook must only be attached to this crane eye.



Caution Before transporting the pump always drain out the oil from the pump first.

2.1.2 Floor

Warning The foundations carrying the pump must be rated as a minimum requirement at 1,000 kg/m².



An inclination of over 10 degrees from the vertical axis is not permissible because of the risk of toppling.

When operating the pump, an angle exceeding 2 degrees from the vertical axis is not permissible.

The ScrewLine should be placed on a flat and level surface.

2.1.3 Air Cooling and Pump Covers

The SP 630 is mostly cooled via its housing with cooling fins on most of its area and with the aid of a radial fan.

Caution The location where the pump is installed must be selected so that an adequate supply and discharge of cooling air is ensured. The minimum clearances are given in the dimensional drawing for the pump.

As standard the ScrewLine is equipped with covers. These ensure even cooling of the ScrewLine and have besides the protective function, also a silencing effect.

Warning The noise level of the ScrewLine corresponds at ultimate pressure with fitted silencers or connected exhaust line to the values given in Chapter 1.3 Technical Data. In all other operating modes and with other equipment, higher values may be attained. Suitable hearing protection measures must be introduced.



Surfaces under the covers of the SP 630 may attain temperatures over 70 °C.

If during maintenance work the covers are removed, there is the risk of suffering burns. Therefore always wear the required protective clothing.



With all covers in place there only the remains the risk of suffering burns at the exhaust port.

Caution Do not operate the ScrewLine with the covers only partly in place (when disassembling one side, for example) since this will impair the steadiness of the air flow cooling the pump.

Make sure that the air cooling arrangement is not impaired. When operating the pump do not leave any items (pieces of cleaning cloth, for example) on the cooling fins of the pump chamber. Clean the cooling fins when they are found to be very dirty.

The pump may be damaged if the cooling air flow is restricted.

2.1.4 Ambient Conditions

The pump may be operated under the ambient temperatures specified by the Technical Data.

At higher ambient temperatures or in the case of a dirty oil cooler, the temperature of the oil can increase to unacceptably high levels. In the case of high ambient temperatures or in the case of dusty ambient conditions the oil cooler should be checked more often (see Maintenance).

Caution The maximum permissible ambient temperature must not be exceeded.

The ScrewLine must be installed such that the side of the exhaust flange remains easily accessible. From this side all maintenance and installation work can be done (see Fig. 5).

2.1.5 Installation Location

At installation locations between 1000 and 3000 m above sea level the following applies to the exhaust pressure p_{ex} at the exhaust:

Max. exhaust pressure relative to the ambient pressure (p_{amb}) $p_{max} = p_{amb} + 200 \text{ mbar}$

Min. exhaust pressure relative to the ambient pressure (p_{amb}) $p_{min} = p_{amb} - 200 \text{ mbar}$

$$p_{min} = p_{amb} - 200 \text{ mbar}$$

Caution The SP-Guard must be used for monitoring.

2.2 Connection to the System

Warning Before installing the pump it must be disconnected from all voltage sources and protected from being switched on inadvertently. Only trained staff may install the pump.
Observe all safety regulations.



Avoid exposing any part of the human body to the vacuum. For this reason never operate the ScrewLine without having fitted an intake line or a blank flange first.

The ScrewLine must not be operated with an open intake port (risk of suffering injury by rotating parts which are within reach).

Before draining condensate from the pump, separate the pump from the process first by a valve as required. Note that process gases and condensate can pose a hazard.

Caution The intake line should be fitted to the pump using a flexible pipe connection so that no mechanical strains will be present.

Always make sure that no small items (bolts, nuts, washers, pieces of wire etc.) enter into the pump through its inlet. For this reason always fit the inlet screen which is supplied as standard with each pump.

Ensure that the pipe is supported if required, in particular in those cases when other components like valves, separators etc. are installed upstream of the pump. The maximum permissible weight on the intake port of the SP 630 is 50 kg.

2.2.1 Connections at the Intake Side

Remove protection foil and desiccant from the intake port (6/1).

Caution When fitting the intake line be sure to select the right materials. These must be capable of resisting the pumped medium. The connecting flanges must be clean and undamaged so as to ensure a leaktight vacuum system.

At the intake side of the pump (6/1) lines which are as short as possible having a minimum nominal width of DN 100 should be used. The same applies also to components like valves fitted in the lines.

The intake line should be clean and free of oil. Dirt, like welding beads or cinder must be removed with care from the intake line.

2.2.2 Connections at the Delivery Side (Exhaust)

It is strongly recommended to always operate the ScrewLine with a connected and suitable exhaust line. The exhaust line should be laid so that it slopes down and away from the pump so as to prevent condensate in the exhaust line from backstreaming into the pump.

Alternatively a condensate separator can be provided directly downstream of the exhaust flange. The filling level of the condensate separator needs to be monitored regularly so that the gas may flow out of the exhaust without being obstructed.

In the case of the optionally available silencer, the condensate separator has already been integrated.

Warning It must be made absolutely sure that any blocking devices installed in the exhaust line, valves or alike, are opened before starting the pump.



SP 630 may generate at the exhaust and with a blocked exhaust line, pressures significantly over 1.5 bar (abs). Thus components can be damaged which do not comply with the EU regulations for pressurised vessels.

Remove the protection foil and desiccant from the exhaust flange (6/4).

Caution The diameter of the exhaust line (6/4) should at least match the diameter of the connection at the pump. The piping should consist of materials capable of resisting the discharged medium. The pipe should be connected to the pump without straining.

Warning The maximum permissible backpressure must not exceed 1200 mbar.



The temperature of the discharged gases and the exhaust port itself may exceed 70 °C.

When connecting the exhaust side to an exhaust gas collecting line, the installation of a non-return valve (P/N 119 010) downstream of the exhaust is recommended. This will reliably prevent any gases from flowing back through the exhaust into the pump.

2.3 Electrical Connection

Warning The electrical connections must be provided by authorised staff of the customer himself.



During all work on the ScrewLine, the mains voltage must be switched off and protected against being switched on inadvertently.

The pump itself is not equipped with any switches. Protection arrangements need to be implemented by the customer.

In order to prevent the pump from running up unexpectedly after a mains power failure, the ScrewLine needs to be integrated in to the system such that the pump can only be restarted manually again. The same applies also to emergency shutdown arrangements.

The electrical connections must only be provided by a trained electrician in accordance with VDE 0105 (DIN EN 50110-1) and in accordance with VDE 0100 (IEC 60364) guidelines.

Note all safety regulations. Before providing the electrical connections note the ratings required for the switches.

The ScrewLine SP 630 must only be operated at its specified frequency.

When operating a 50 Hz pump at 60 Hz, or a 60 Hz pump at 50 Hz, the ScrewLine can suffer damage.

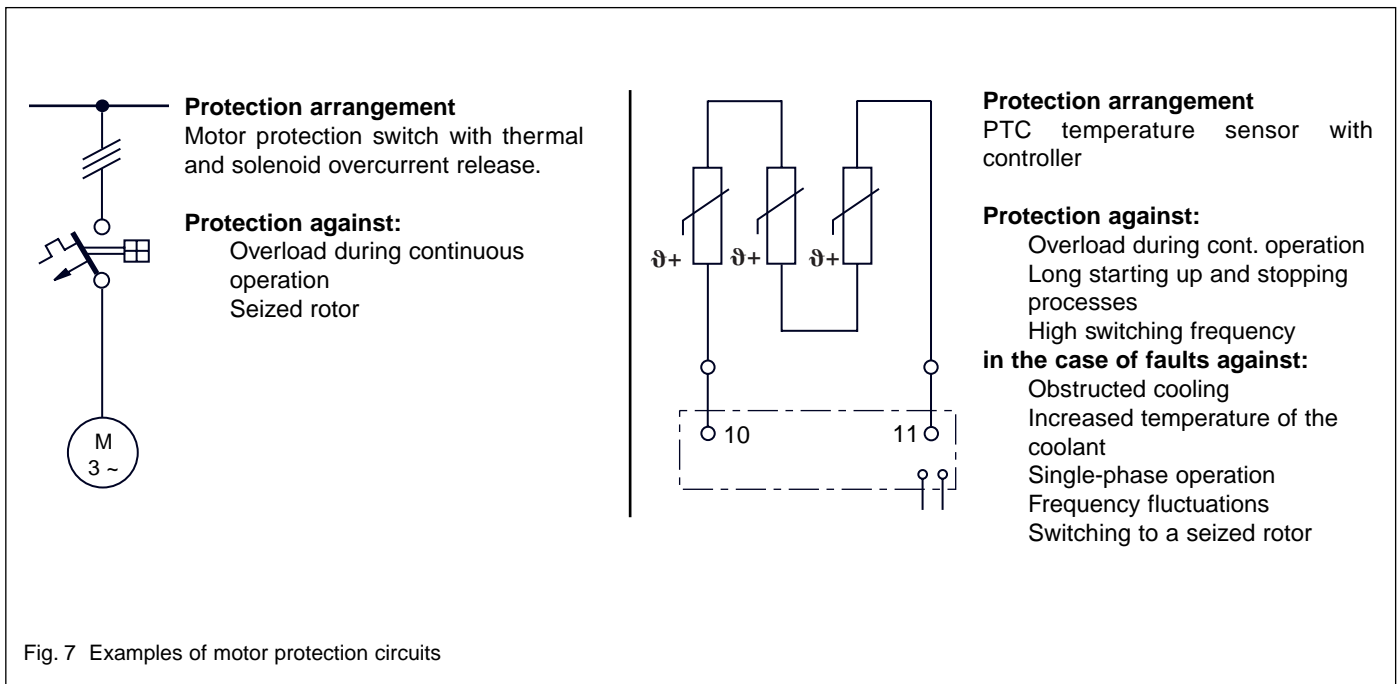

Fig. 7 Examples of motor protection circuits

2.3.1 Motor Protection

Caution The electric motor (junction box Fig. 10/1) is equipped with a class 20 thermal overload protector (in accordance with IEC 60947-4). Motor protection switches of class 20 will respond with a delay of 20 seconds at the most.

In line with local requirements, the setting for the motor protection switch can be taken from the following U/I diagrams given on page 18 in the case of a Δ connection. When connecting the pump in a $\Delta\Delta$ circuit the values read off from the diagram (Δ circuit) need to be doubled.

Note The number of operating hours of the SP 630 should be acquired on the side of the system by an operating hours counter.

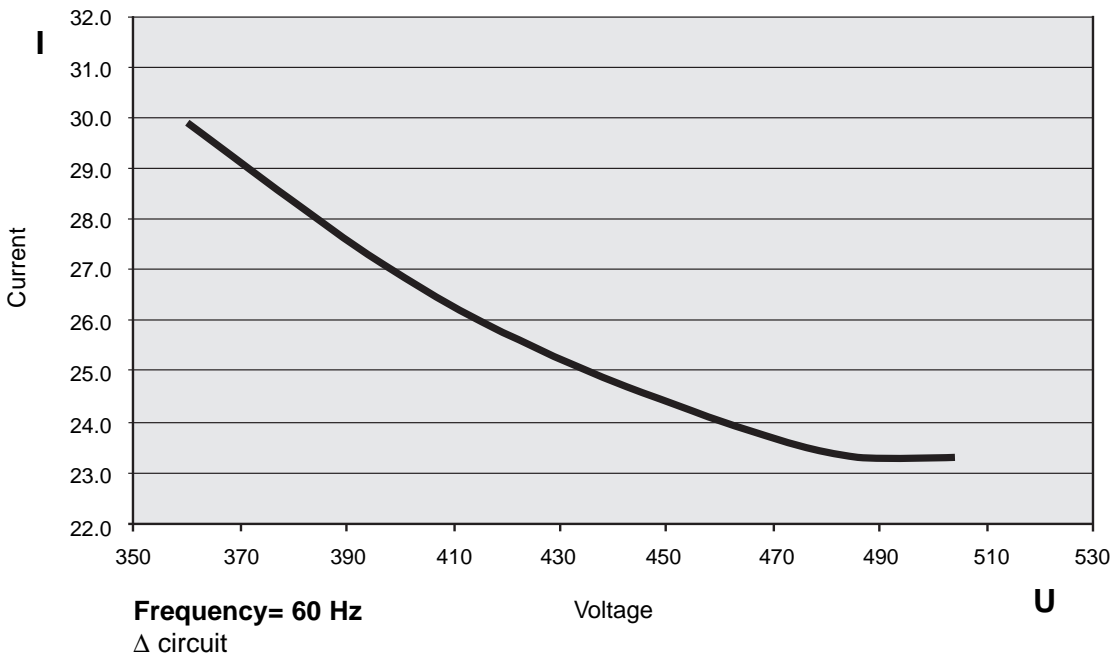
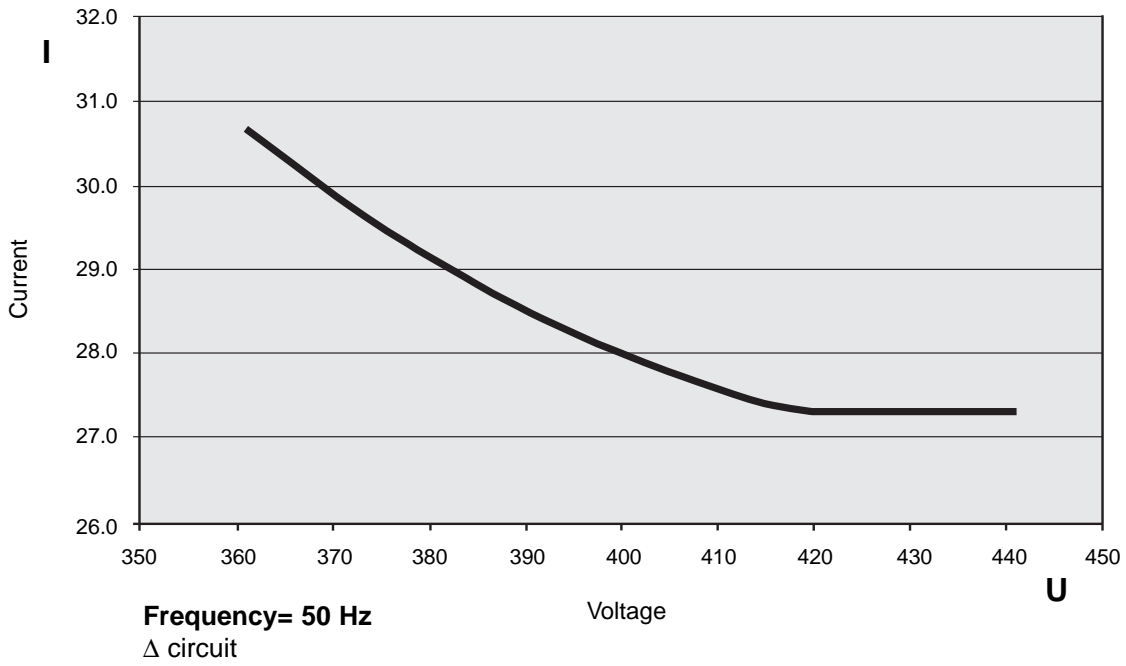

Diagram 1 Voltage/current diagram

2.3.2 Soft Start

To reduce the current surges when switching on and to increase the service life of the various components, a soft start arrangement can be implemented.

Set-up recommendation

Ramp up time: 5 seconds
 Starting voltage: 95 %

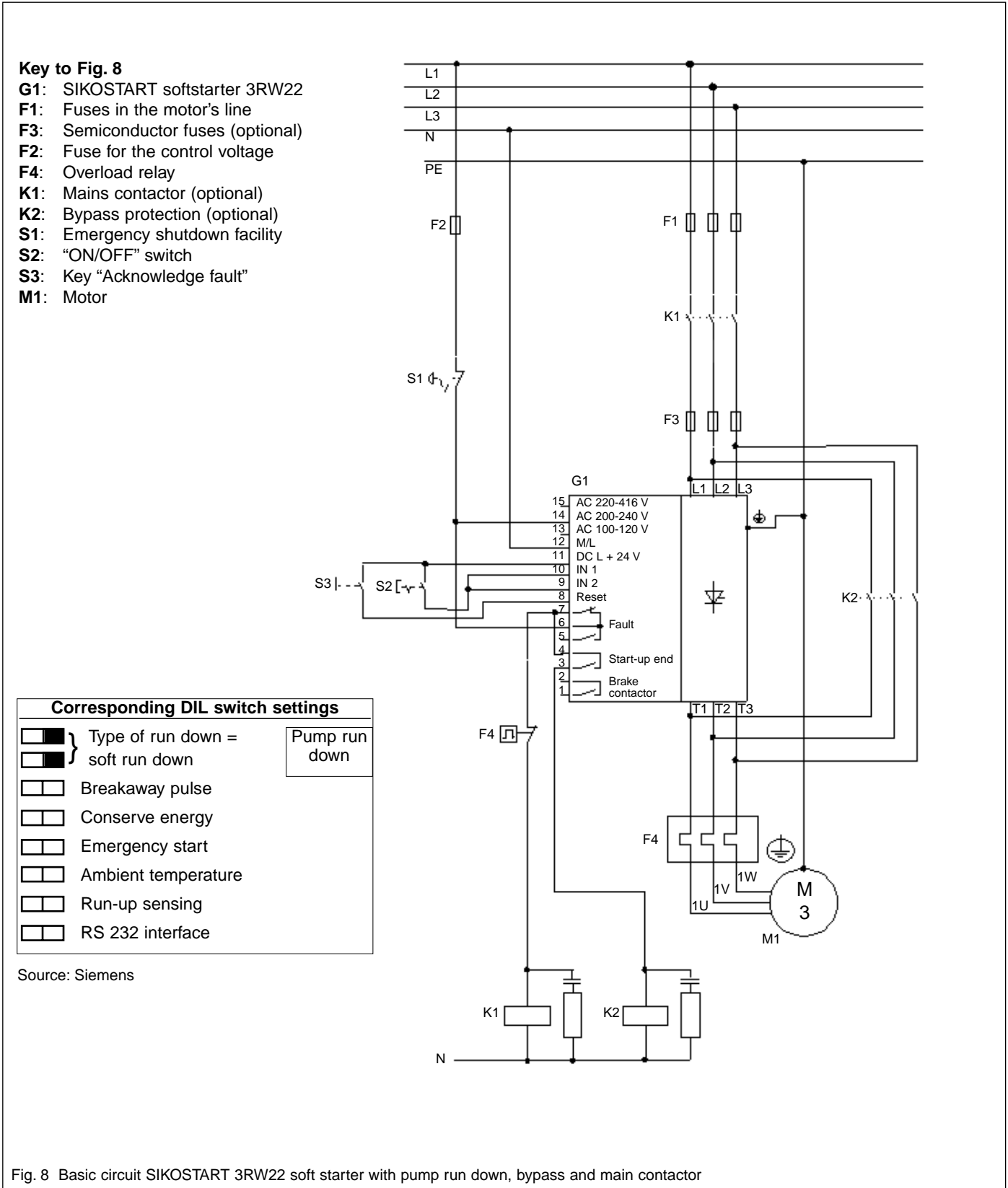

2.3.3 Mains Connection

Caution The pump is not equipped with any switches. Protection schemes must be provided externally by the customer.

The mains power needs to be supplied via an external mains switch with ON/OFF key by the customer.

The mains connection needs to be provided in accordance with the type of motor protection. The mains supply must match the mains power rating of the motor.

Warning After a mains power failure the pump will run up automatically as soon as the mains power returns.



The motor rating is given in Chapter 1.3 “Technical Data”.

Caution As a rule, the pumps are supplied by Leybold turning in the clockwise direction on the load side, with the direction of rotation being anticlockwise for the ventilation side (see Fig.13).

For the power connecting lines from the side of the customer a clockwise rotating field needs to be ensured. Please check this with a direction of rotation measuring instrument.

After having connected the pump check the **direction of rotation** of the motor. This should be done at atmospheric pressure in the intake line (switch the valves accordingly). Thereafter open the fan's housing (13/2). Let the pump run up briefly (about 1 s). During this time observe the fan's direction of rotation (Fig. 13). The correct direction of rotation is indicated by arrows on the fan's housing. Then close the housing again.

When incorrectly connecting the motor of the pump, it may only be operated running in the reverse direction for a maximum of three seconds. Longer operation in the reverse direction will cause damage to the pump.

It is best to check the direction of rotation involving two persons. If possible check the direction of rotation of the SP 630 with the intake line open but with the inlet screen secured in place.

Warning Except when checking the direction of rotation the pump must never be operated with its housing open.



There is the risk of suffering injury due to hot surfaces. Moreover, sufficient cooling of the pump is not ensured when the housing is open.



2.3.4 Power Failure

Caution When connecting the pump to a vacuum chamber, a suitable valve (electric blocking valve, for example) needs to be connected on the intake side for interrupting the intake line so as to prevent the pump from running backwards in the event of a power failure. Otherwise the pump may suffer damage. This valve needs to be controlled from the side of the system controller such that the intake line is interrupted in the event of a power failure.

2.3.5 Frequency Converter

Caution If for a SP 630 pump specified for operation with a nominal mains frequency of 60 Hz only a 50 Hz mains supply is available, a frequency converter may be used so as to produce the nominal frequency of 60 Hz. Here it needs to be noted that the residual ripple from the frequency converter must not exceed 15%.

Shielded cable types must be used for supplying power to the motor. The pump must be linked to ground potential using an additional ground strap.

The frequency converter must supply power to the motor through a motor filter. The frequency converter must not be used to control the speed of the pump.

Three phase motor
Selectable voltage 1:2

1 Speed
1 Coil

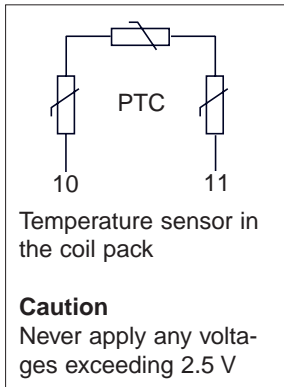

Δ - Delta circuit

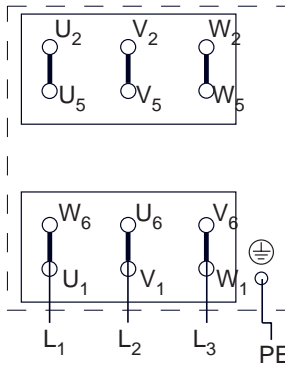

ΔΔ - Delta circuit U/2

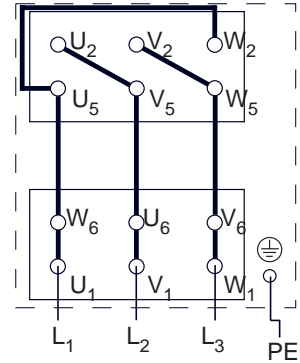

Y - Star circuit

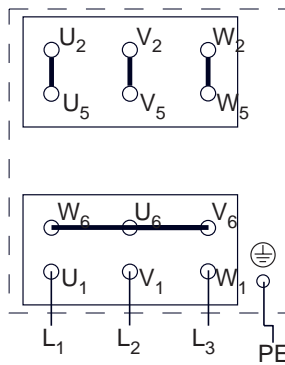

YY - Star circuit U/2

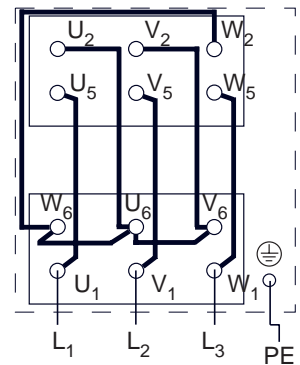

Fig. 9 Mains connection (diagrams in the junction box)

2.4 Start-Up

Warning The pump must only be commissioned by trained staff.



2.4.1 Oil Filling for the Gear

Caution The ScrewLine is supplied without oil in its gear.
Before commissioning, the separately supplied gear oil must be filled into the gear. When doing so make sure that all aids used are clean so as to avoid contaminating the oil.
Use only lubricating oil which has been approved by Leybold.

The gear oil should be filled in at room temperature. At lower temperatures, the oil is thicker so that there then is the risk of over-filling gear chamber with oil.

For filling in oil, the cover section (11/1) on the exhaust side must be disassembled. For this unlock the closure screws (Fig.11/item X) at the cover of the ScrewLine (7 pieces) and remove the cover section.

Caution For the closure screws you will require a special square key. This key is included with the ScrewLine SP 630.

Remove the oil fill plug (10/3) and fill in the lubricant. When doing so, make sure that the oil level, after filling, will be at the level of the maximum mark (see Fig. 10.1).

Note The filling quantity of 15 litres of oil may be too much, if there is still some residual oil in the pump.

In the case of pumps which are being operated with the SP-Guard, it needs to be ensured that the oil level is filled up to the "maximum mark".

Clean the oil fill port and screw the oil fill plug in again using a gasket which is in perfect condition.

The oil fill port must be sealed air-tight.

For checking the oil level and for changing the oil see Chapter 3.1.1.

When switching the pump on and off the oil level may fluctuate visibly. During operation of the pump the oil level will be between the maximum and the minimum mark (see Fig. 10.2). As soon as the oil level during operation of the pump drops to the minimum mark, oil must be topped up (see Fig. 10.3).

The type of gear oil is specified in Chapter 1.3 "Technical Data"

After having filled in the oil, the cover must be fitted once more.

The two cover sections are fitted in the reverse order as described.

Caution While fitting, the pegs at the cover sections must engage into the corresponding bores. This will ensure that the cover sections are properly seated and, moreover, otherwise the covers cannot be properly fitted.

Before commissioning, ensure that the pump and the fitted accessories match the requirements of your application and that safe operation can be ensured.

Warning

Avoid exposing any part of the human body to the vacuum. There is the risk of suffering injury. Never operate the pump with the intake port open.



Caution

Vacuum connections as well as the oil fill and oil drain ports must never be opened while the pump is running.

The safety measures relevant to the application in each case need to be observed. This applies to installation, operation and maintenance (servicing) as well as waste disposal and transport.

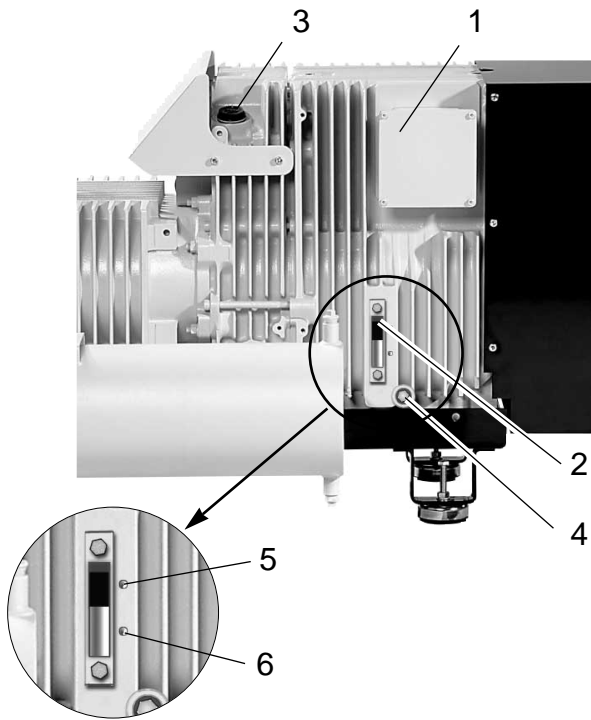

Note

A float in the oil level glass is present only in the case of those pumps which are equipped with an SP-Guard.

Key to Fig. 10

- 1 Junction box
- 2 Oil sight glass
- 3 Oil fill plug
- 4 Oil drain plug
- 5 Oil level mark "Maximum"
- 6 Oil level mark "Minimum"

Fig. 10 Oil level, oil sight glass and junction box (ScrewLine with covers removed)

Pump not in operation Oil level maximum (for initial filling)

Fig. 10.1

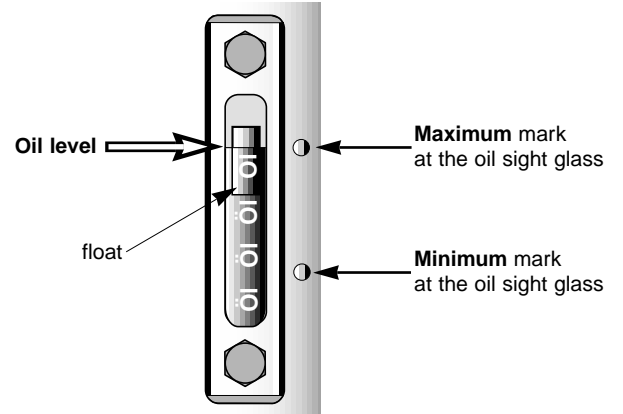

Pump operating Oil level between maximum and minimum

Fig. 10.2

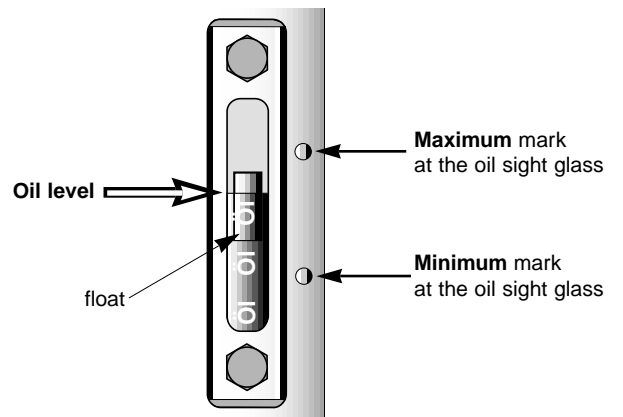

Pump operating Oil level at minimum (top up oil!)

Fig. 10.3

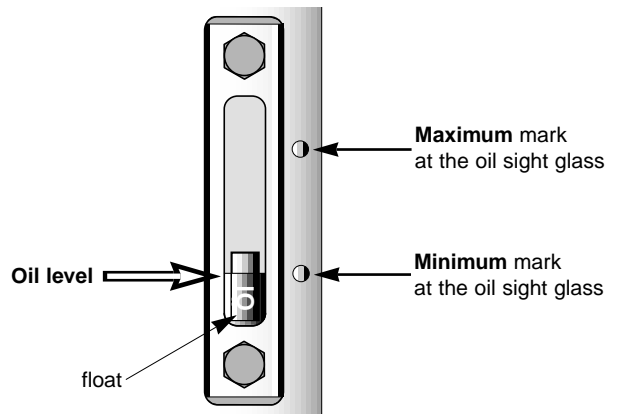

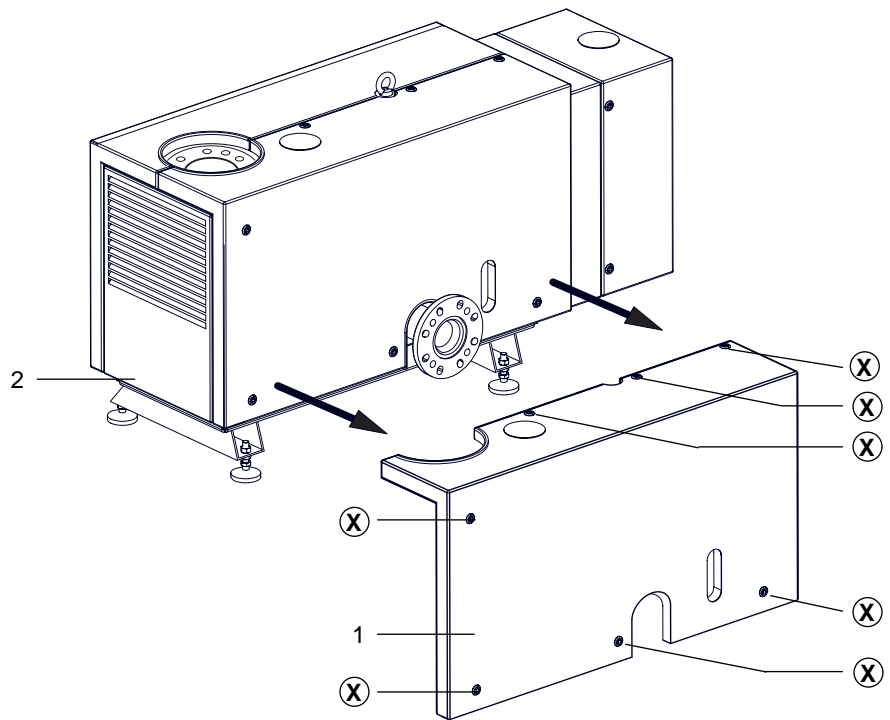

Key to Fig. 11

- 1 Cover section / exhaust side
- 2 Panel for guiding the discharged air

(X) Closure screws (7x)

Fig. 11 Unlocking the closure screws and removing the cover section from the ScrewLine SP 630

2.4.2 Switching the Pump On

Note the safety information given on pages 4 and 5.



Warning The pump may only be switched on after it has been completely assembled and with the fan's housing closed. Operation without intake and exhaust lines, or the silence are not in place is not allowed. In the exhaust line no pressure (>1,200 mbar abs) must be allowed to build up even if the discharged gases need to be collected or contained. Make sure that the gas flow at the exhaust is not blocked or restricted in any way.

Caution

Start the pump only six times per hour at the most so as to avoid overloading the motor.

The ScrewLine is equipped between its pump chamber and gear with non-contact seals. These seals are equipped with a vent underneath the pump. By design, small amounts of gear oil may escape through this vent. This will not adversely affect operation of the pump. The motor housing is vented via a channel which opens out beside the motor's junction box. By design, small amounts of gear oil may escape through this vent. This will not adversely affect operation of the pump.

Preferably start the ScrewLine with the intake line open, i.e. at atmospheric pressure at its inlet. Under these conditions the run-up current surge will be minimal.

The pump will attain its operating temperature about 30 minutes after starting.

2.4.3 Oil Temperature

The temperature of the oil is influenced by the load on the pump, the ambient temperature and the cleanness of the oil cooler.

The temperature of the oil may be measured by the system controller using a standard temperature sensor (Pt 100) or via the SP-Guard (which is optionally available). It measures the temperature of the oil ahead of the oil cooler.

Caution If during normal loads and ambient temperatures the temperature of the oil deviates from the process dependent standard levels, the oil cooler should be checked to see if it has accumulated any dirt (see Chapter "Maintenance"). The temperature of the oil should not exceed 80 °C.

The way in which the Pt 100 sensor is connected is described in Chapter 2.8 "Pump Monitoring".

2.4.4 Regular Checks

(Note also Chapter 3 "Maintenance")

Reliable and safe operation is ensured when running the following checks regularly:

- Oil level check
- Check on the oil cooler for accumulated dirt (refer to Chapter 3.2 "Cleaning the Oil Cooler")
- Emptying the condensate separator (optional)
- Check the readings on the SP-Guard (optional) (temperatures and vibration levels)
- Cleaning the dirt trap

A wire-mesh filter is located in the pump's intake port to act as a dirt trap for impurities. It should be kept clean at all times in order to avoid reduction of the pumping capacity.

For this purpose, disconnect the intake line, remove the dirt trap from the intake port and clean it in a suitable way. If the dirt trap is defective, replace it.

The cleaning intervals depend on requirements. If large amounts of abrasive materials occur, a suitable dust filter should be fitted into the intake line.

The interval between the regular checks will depend on the ambient conditions and the process in each case and needs to be defined based on experience gained during operation. The temperature of the oil and the dirt accumulated on the oil cooler will have to be checked more frequently when the pump is being operated in a dusty environment. If much condensate is collected, the condensate separator will have to be checked regularly.

2.5 Operating Conditions

The ScrewLine should normally be operated continuously. If possible do not switch the pump off for less than one hour. In the case of process interruptions preferably operate the pump with the inlet blocked off, since during operation at ultimate pressure power consumption will be minimal.

Caution The pump will have attained its operating temperature about 30 minutes after starting.

Before pumping condensable vapours the ScrewLine should have attained its operating temperature first.

Caution Pumping of vapours which will condense when compressed in the pump should be avoided.
If vapours need to be pumped regularly, condensate separators should be fitted in the intake and the exhaust lines. Fitting of an optionally available gas ballast valve is also recommended.
If the process is dusty, suitable dust filters must be fitted upstream of the pump.

Warning The ScrewLine pump is **not** suited for pumping of:

- combustible and explosive gas mixtures
- radioactive and toxic substances
- pyrophorous substances
- Gas mixtures with an oxygen share of >21 percent by volume.



Moreover, the ScrewLine is not suited for installation and operation in explosion hazard areas.

In order to avoid dangerous conditions it needs to be checked before commissioning the pump whether the media which are to be pumped are compatible with the pump.

The highest permissible intake pressure is 1030 mbar.

The ScrewLine may be operated at a pressure at its exhaust flange ranging between 800 mbar (abs.) and 1200 mbar (abs.)

Make sure that the gas flow at the exhaust is in no way blocked or restricted and that the pressure can not increase over 1200 mbar (abs.)

All relevant safety standards and safety regulations must be observed.

Note

After having commissioned the pump and after the pump has been at standstill for a longer period of time, the SP 630 may generate more noise than usual. This noise is caused by the higher viscosity of the oil at low oil temperatures. As the oil temperature increases the noise level will drop. The increased noise level will not adversely affect the operational reliability of the pump.

2.6 Switching Off / Shutting Down

Close the intake line.

Switch the pump off.

The pressure in a pump which has been switched off will increase within a few seconds to the level of the exhaust pressure (normally = ambient pressure). The ScrewLine is not equipped with any means to protect the vacuum. For this reason use, if needed, a valve (anti-suckback valve) fitted in the intake line which will automatically close the intake port of the ScrewLine upon standstill of the pump (for example, SECUVAC valve P/N.: 105 70).

Caution In order to prevent damage due to standstill of the pump, a post operation phase of at least 30 minutes with the gas ballast open is recommended after termination of the process, if the process gas contains corrosive, condensable substances or substances which tend to form deposits.
In the case of prolonged standstill times (over three weeks) further measures besides letting the pump run dry need to be introduced for the purpose of avoiding corrosion due to standstill.
For this please contact Leybold for advice.

2.7 Emergency Shutdown

The customer himself must ensure that the mains wiring is rated corresponding to the mains voltages and nominal currents. A mains circuit breaker resp. an emergency switch must be so arranged that the supply of mains power is completely interrupted so as to prevent the pump from running up unexpectedly.

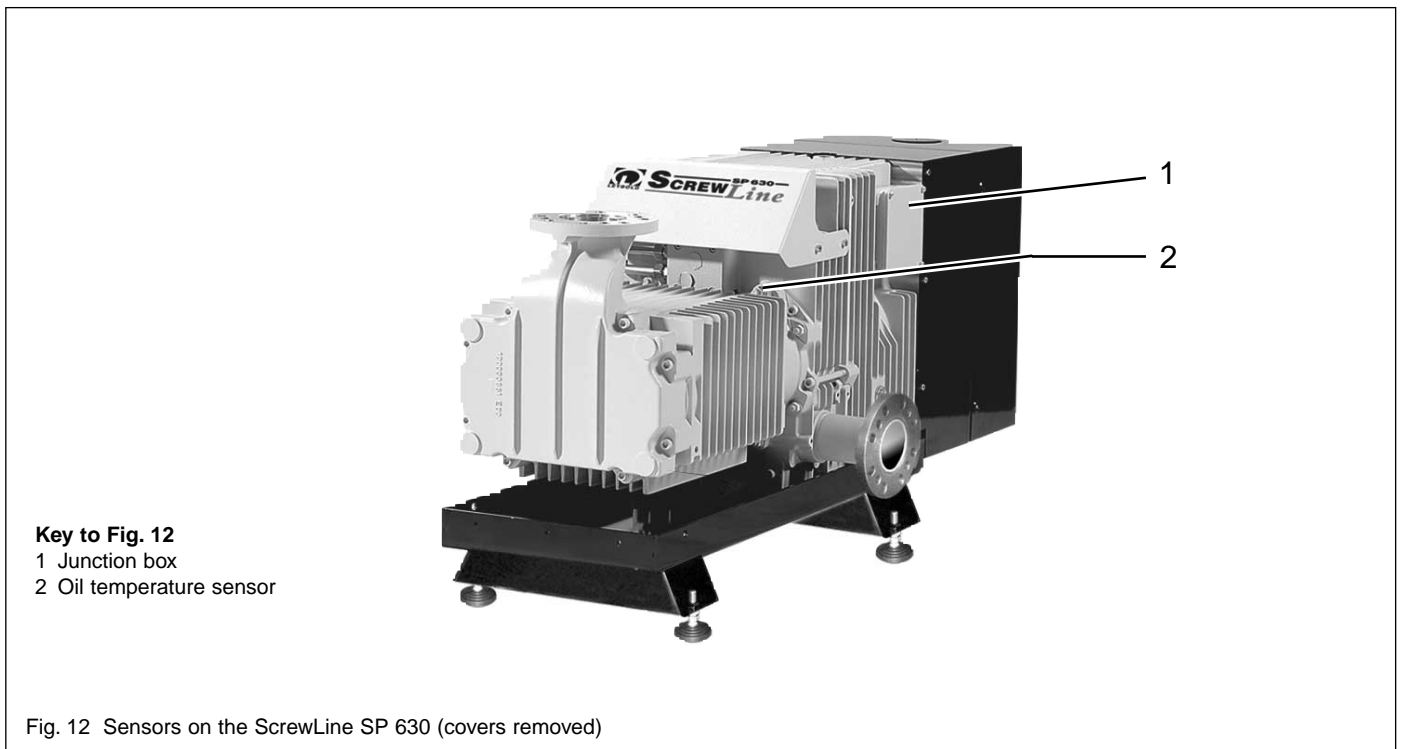

2.8 Pump Monitoring

2.8.1 Oil Temperature Sensor PT 100

For the purpose of monitoring the oil temperature, a temperature sensor (JUMO 902004/10) (12/2) has been installed on the pump.

This oil temperature sensor is of the Pt 100 type in accordance with DIN 60751 Class B and used in a two-wire circuit.

The Pt 100 should be integrated with the plant controller by an electrician so that the ScrewLine pump will automatically be shut down as soon as the max. permissible temperature of 80 °C is exceeded.

Caution If the temperature of the oil deviates during normal loads and ambient conditions from the process dependent standard values, the oil cooler should be checked to see if it has accumulated any dirt (see Chapter "Maintenance").

If an optionally available SP-Guard (monitoring system) has been installed on the ScrewLine, then the PT 100 has also been connected and its output is automatically monitored. The PT 100 needs **not** to be connected separately.

3 Maintenance

Warning During all maintenance and servicing work on the ScrewLine, the pump must be disconnected from all sources of electrical power.



The pump must be reliably prevented from running up inadvertently.

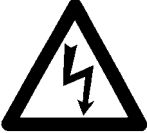

All work within the pump should be left to suitably trained staff. Improper maintenance and repair work will significantly impair the durability or operation of the pump and can result in difficulties when filing warranty claims.



Moreover, it needs to be ensured that no gas can flow backwards through the pump since this might cause the rotors to turn. For this reason vent the vacuum chamber to the level of the exhaust pressure or ensure through suitable valves that vacuum chamber and the lines are reliably separated from the pump.



If the pump has been pumping hazardous substances, determine the kind of hazard first and introduce suitable safety measures.



Never operate the pump with its pump chamber open or with the fan's housing removed. There is the risk of suffering injury.



Note that the surface of the pump can get hot. Leave the pump to cool down or wear suitable protective clothing.

Observe all safety regulations.

Caution When disposing of waste oil and used oil filters observe the applicable environment protection regulations.

Use only original spare parts from Leybold.

Ensure that the following maintenance work is done: (for this also refer to the table in Section 3.6)

- Regularly check the oil cooler to see if it has collected any dirt and clean as required (see Chapter 3.2).
- If a condensate separator is present, empty it regularly.
- If a dust filter is present check it regularly and clean it as required.
- Regularly check the oil level and top up oil as required.
- Oil change and oil filter change (once per year).
- Replace the axial bearings after 18,000 operating hours.

3.1 Checking the Oil Level

Warning Note that the oil, while it is still warm, can cause burns and use the necessary protection equipment.



The intervals between the regular checks should be based on the ambient conditions and your experience.

Upon switching the pump on and off, the oil level may fluctuate visibly.

With the pump at standstill the oil level must be between the maximum and the minimum mark (see Fig. 10). As soon as the oil level during operation of the pump drops to the minimum mark, oil must be topped up (see Fig. 10.3).

3.1.1 Oil Change and Oil Filter Change

Caution Change the oil while it is still warm and only while the pump is a standstill. Place a sufficiently large collecting vessel (about 20 litres) under the ScrewLine. When disposing of the waste oil observe the applicable environment protection regulations. Use only lubricants approved by Leybold.

To change the oil, the cover section on the exhaust side needs to be disassembled (see Chapter 2.4.1).

Unscrew the oil drain plug (10/4) and the oil fill plug (10/3) and drain out the oil.

Clean the sealing surface and firmly screw in the oil drain plug (10/4) using a gasket which is in perfect condition. Wipe off any oil residues on the housing.

3.1.1.1 Replacing the Oil Filter

Open the fan's housing (13/2) and screw the oil filter housing (13/4) open (place a collecting vessel for the small amount of oil underneath).

Remove the filter and replace it by a new one. Thereafter close the filter housing and the fan's housing once more.

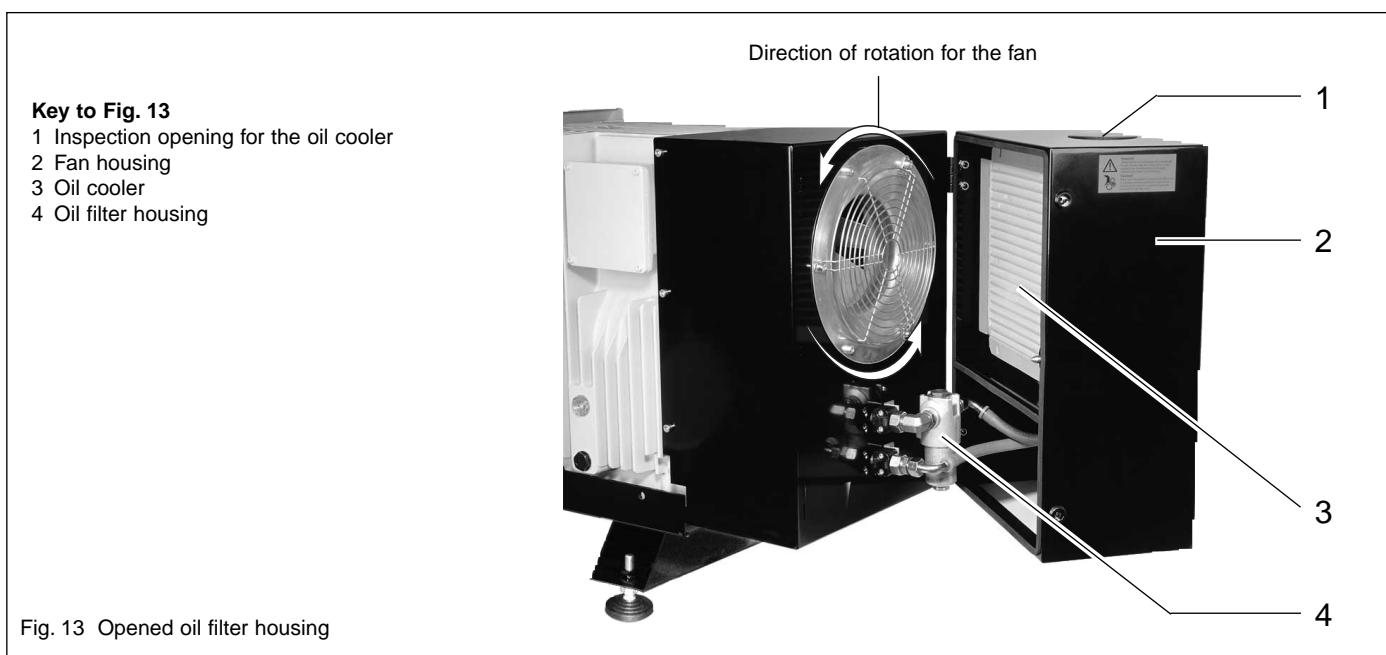

3.1.1.2 Exchanging the Oil

Fill in the fresh gear oil.

Caution When doing so, make sure that the aids used are clean so as to avoid contaminating the oil.

For oil quantity and ordering data for the oil see Chapter 2.4.1 and Fig. 10.

Clean the oil fill opening and screw on the oil fill plug (10/3) using a gasket which is in perfect condition. Wipe off any oil residues from the housing.

Caution The oil fill opening must be sealed off air-tight. With the pump at standstill the oil level must be between the maximum and the minimum mark (see Fig. 10).

After having exchanged the oil, the cover section on the exhaust side must be fitted once more (see Chapter 2.4.1).

3.1.1.3 What to do when too much Oil has been filled in

If too much oil has been filled in, then you should proceed as follows:

1. With the pump at standstill, drain out so much oil that the oil level drops below the maximum mark.
2. Operate the pump for at least one hour.
3. Then visually inspect the rotors and the rotor housing to see if any unwanted oil leaks are present.
4. If required, repeat steps 2 and 4.

3.2 Cleaning the Oil Cooler

Caution Regularly check the oil cooler to see if it has accumulated dirt. The interval between the regular checks will depend on the ambient conditions and the process in each case and needs to be defined based on experience gained during operation.

For this run a visual inspection through the inspection opening on top of the cooling unit (13/1).

A dirty cooler may cause increased oil and pump temperatures and impair operation and reduce the service life of the ScrewLine.

With the pump at standstill, the fan's housing may be opened so as to clean the oil cooler.

Warning Switch the pump off and ensure that it can not be started up inadvertently.



Do not operate the pump with the fan housing open (only exception: direction of rotation check, Fig. 13). The ScrewLine may be damaged severely due to inadequate cooling.

Open the fan's housing and clean the cooler with compressed air from the accessible side.

Warning Clean the cooler only while the pump is at standstill.



If it is not possible to stop the pump, then in such a case the cooler may, if required, be cleaned from the top through the inspection opening (13/1) using a vacuum cleaner.

Warning While blowing out the pump with compressed air you must wear protective goggles so as to protect your eyes.



3.3 Draining Out Condensate (optional)

The condensate separator must be checked regularly especially if much condensate is collected.

The interval between the regular checks will depend on the ambient conditions and the process in each case and needs to be defined based on experience gained during operation.

Empty the condensate separator.

Warning To drain the condensate out, the pump will possibly have to be separated from the process by a valve. Please note that process gases and condensate may present a hazard to health.



3.4 Cleaning the Dust Filter (optional)

The dust filters which are installed upstream of the ScrewLine need to be checked regularly for contamination and cleaned as required.

3.5 Leybold Service

If a pump is returned to Leybold, indicate whether the pump is free of substances damaging to health or whether it is contaminated.

If it is contaminated also indicate the nature of the hazard. For this you must use a form prepared by us which we will make available upon request.

A copy of this form is reproduced at the end of these Operating Instructions: "Declaration of Contamination of Compressors, Vacuum Pumps and Components."

Affix this form to the pump or enclose it with the pump.

This Declaration of Contamination is required to meet the requirements of our laws and to protect our staff.

Leybold must return any pumps received without the declaration back to the sender.

Before packaging the pump (or shipping it) the pump should be purged with inert gas, but as a minimum requirement it should be completely emptied from substances it has been pumping out before.

This may also apply to all parts belonging to the pump system, like coolers, vessels, etc.

Warning Package the pump so that it will not be damaged during shipping and so that no hazardous substances can escape from the packaging.



3.6 Table / Maintenance and Service Work ScrewLine SP 630

| Maintenance and Service ScrewLine SP 630 | Periodical / If required | | Annual | | 18,000 h | | 43,000 h | | Carried out by | Where to do | Materials | Note |
|--|--------------------------|---|--------|---|----------|--|----------|---|--|----------------------------------|--|---|
| | x | | x | | x | | x | | | | | |
| Checking and draining the exhaust silencer (optional accessory) | x | | | | | | | | Operator | On site | | Refer to operating Instruction exhaust silencer |
| Cleaning the dust filter (optional accessory) | x | | | | | | | | Operator | On site | | Refer to operating Instruction dust filter |
| Checking and cleaning the gas ballast valve (optional accessory) | x | | | | | | | | Operator | On site | | Refer to operating Instruction gas ballast valve |
| Checking the oil level | x | | | | | | | | Operator | On site | | Refer to operating Instruction ScrewLine - Chapter 3 Maintenance |
| Checking and cleaning the oil cooler | x | | | | | | | | Operator | On site | | Refer to operating Instruction ScrewLine - Chapter 3 Maintenance |
| Oil change and oil filter change | | x | x | x | | | | | Operator or Leybold Field-Service | On site | EK 110000792 | Refer to operating Instruction ScrewLine - Chapter 3 Maintenance |
| Inspection and cleaning the screw rotors | x | | x | x | | | | | Operator or Leybold Field-Service | On site | EK 110000793 | Required training offered by Leybold Vacuum ¹⁾ |
| Change of axial bearings | | | x | x | | | | | Operator or Leybold Field-Service | On site | EK 110000792 EK 110000793 EK 110000794 | Required training offered by Leybold Vacuum ¹⁾ |
| Full-Service | | | | | | | | x | Leybold Service Service Center¹⁾ | Authorised Service Center | | Full-Service carried out by authorised Leybold Service Center only |

¹⁾ refer to service-addresses

4 ScrewLine SP 630 F - Water Cooled

The areas of application of the ScrewLine SP 630 F are in small and air-conditioned rooms so as to prevent unnecessary heating of the ambient air.

The water cooled pump is also used under much contaminated ambient conditions since under such conditions otherwise rapid accumulation of contamination on the air heat exchanger is to be expected.

The ScrewLine SP 630 F is equipped with a water cooled heat exchanger to cool the oil.

The water connections are depicted in Fig. 15 and before operating the pump these need to be connected by the customer.

Warning For this switch off the pump first and ensure that it cannot be started up unintentionally.



Caution Operation without cooling water will cause damage to the pump. The pump is supplied without cooling water in the heat exchanger.

Warning Never operate the pump with the fan cover open.



Only open the fan cover while the pump is at standstill. In the case of limited or inadequate cooling, the ScrewLine SP 630 F can suffer severe damage.

4.1 Technical Data

(Supplementary to Chapter 1.3)

| | |
|---|---|
| Water connection (2x) | G 1/2" |
| Water supply temperature | 5 °C - 35 °C |
| Maximum supply pressure (p _{max}) | 16 bar |
| Minimum supply pressure (p _{min}) | 2 bar |
| Nominal flow at a water supply temperature of 25 °C | 12 l / min |
| Cooling air/water | (50% / 50% approx.) ¹⁾ (at a supply temperature of 5 to 25 °C) |
| | (70% / 30% approx.) ¹⁾ (at a supply temperature of 25 to 35 °C) |

¹⁾ applies to room temperatures of 20 - 25 °C

4.2 Water Quality

Contamination:

The content of suspended solids should remain below 10 mg/l.

Particle size < 0.6 mm (globular).

String shaped solids will rapidly increase the pressure losses.

Corrosion:

The following limit values refer to a pH value of 7.

- free chlorine, CL₂ < 0.5 ppm

- chlorine ions

CL < 700 ppm at 20 °C

CL < 200 ppm at 50 °C

Other limit values:

- ph 7 - 10

- sulphate SO₄²⁻ < 100 ppm

- [H CO₃⁻] / [SO₄²⁻] > 1

- ammonium NH₃ < 10 ppm

- free CO < 10 ppm

Under normal conditions the following ions are not corrosive:

Phosphate, iron, nitrate, nitrite, manganese, sodium, potassium.

Caution The cooling water from the return does not have the quality of drinking water and should in no way be used for this purpose.

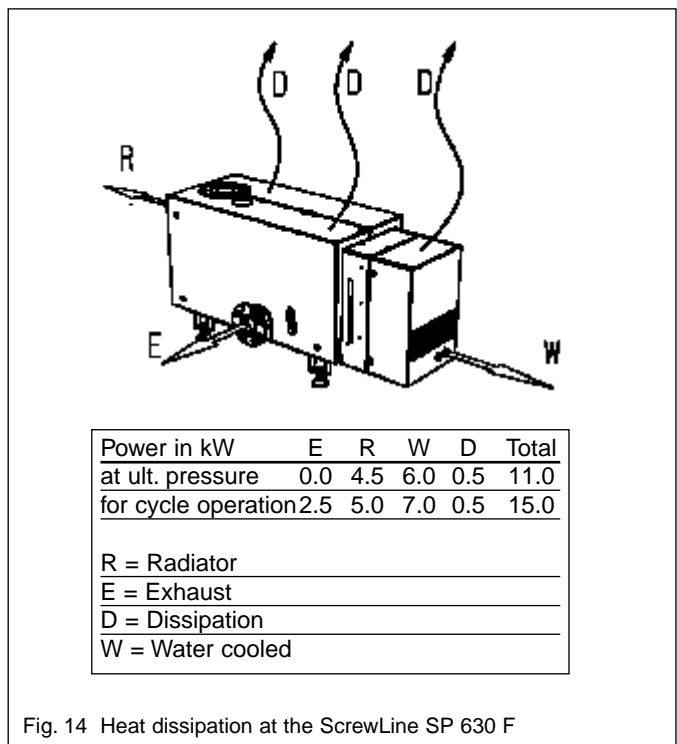
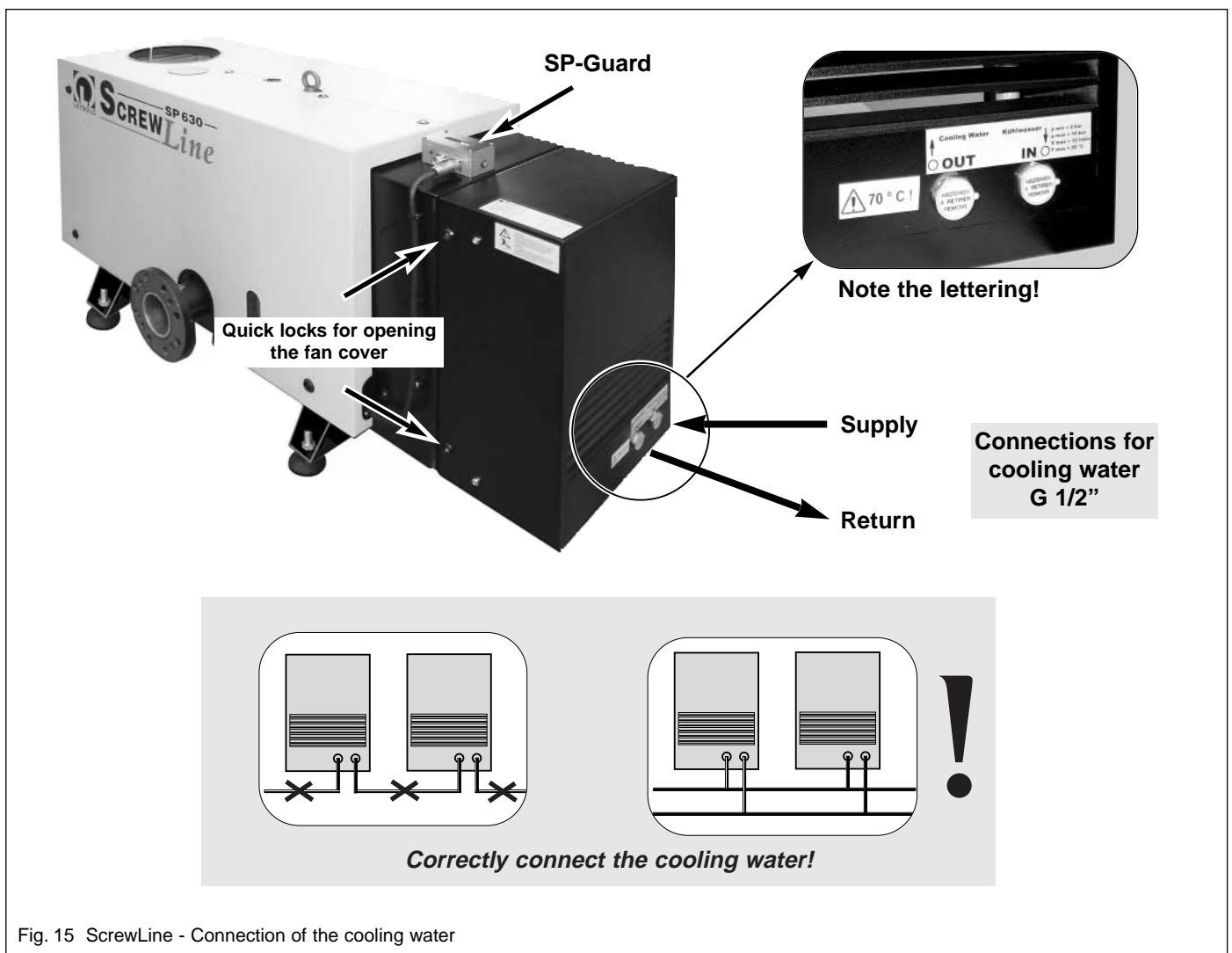

Fig. 14 Heat dissipation at the ScrewLine SP 630 F



4.3 Connecting the Cooling Water

- Unlock the quick locks at the fan cover and open the fan cover (Fig. 15).
- The thermostatic valve (Fig. 16) should be set to 2.5 (factory default) and then close the fan cowl.

Caution Do not confuse water supply and return; see Fig. 15.

For the cooling water connections use only flexible hoses of sufficient pressure and temperature resistance.

- Connect cooling water line (supply).
- Connect cooling water return.

Note Only at an oil temperature of approximately 40° C will the thermostat open and the cooling water flow. At 20° C this takes approximately 10 minutes.

Caution In the case of several pumps, each pump must be connected **separately** to the cooling water. A “series connection” of several pumps is not permissible as otherwise due to the control action of the thermostat valve this may cause an interruption to the cooling water flow.

Note Cooling water throughput may vary between 0 and 12 litres per minute depending on the temperature of the cooling water.

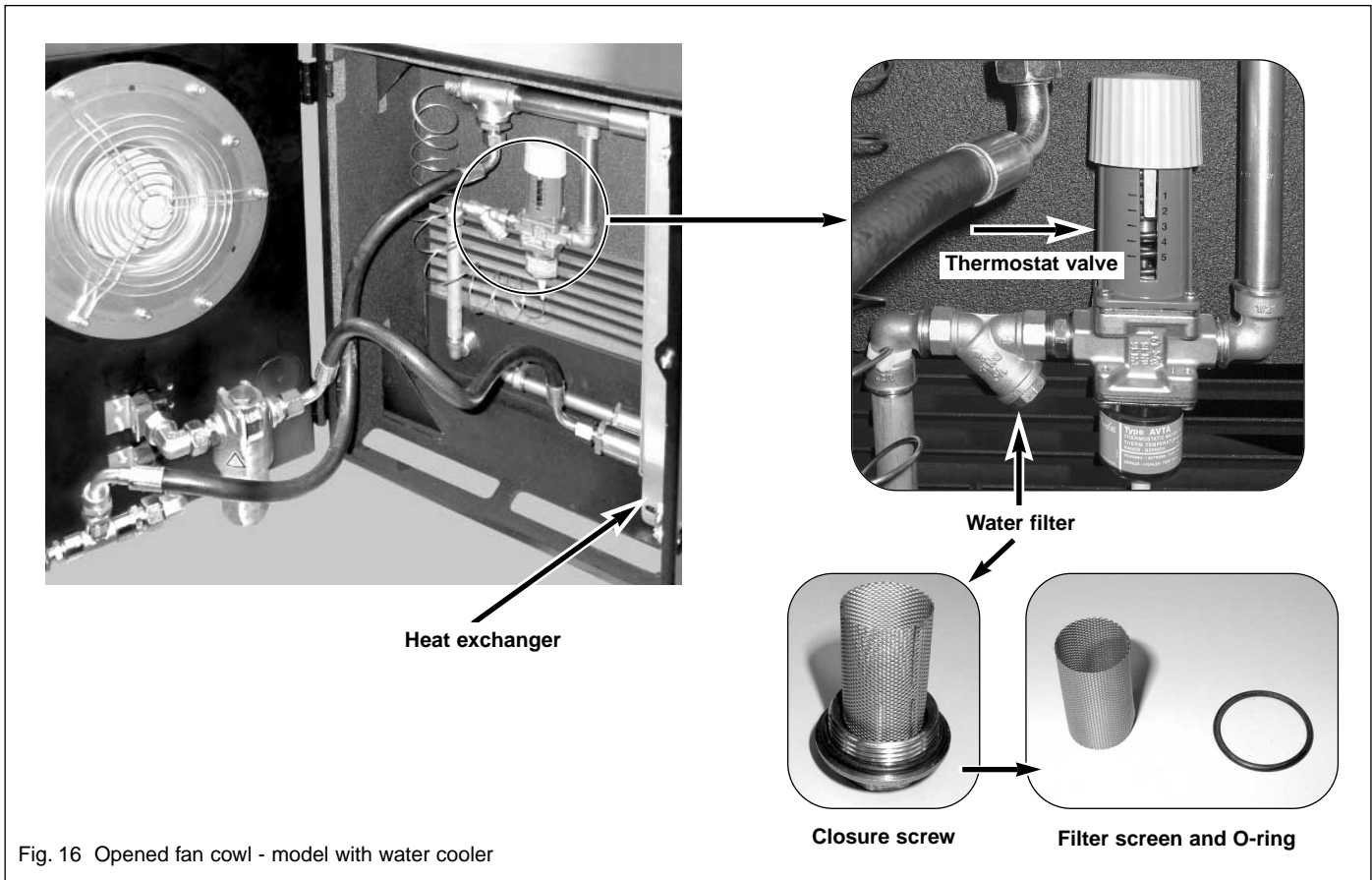

Fig. 16 Opened fan cowl - model with water cooler

4.4 Oil Temperature

During normal operation the oil temperature will be $40\text{ }^{\circ}\text{C} \pm 3\text{ }^{\circ}\text{C}$, provided a setting of 2.5 is used on the thermostat valve (Fig. 16).

The oil temperature can be read off from the display of the SP-Guard.

The maximum permissible oil temperature during normal operation is $60\text{ }^{\circ}\text{C}$. As soon as this temperature is attained, the SP-Guard will output a warning message. At an oil temperature of $70\text{ }^{\circ}\text{C}$ an error message is output.

Caution Thermostat settings of 4 and 5 must not be used since then damage may be caused by insufficient cooling.

The signals from the SP-Guard need to be processed through a system controller (PLC).

Note At water temperatures over $25\text{ }^{\circ}\text{C}$ the thermostat will no longer be able to maintain a constant oil temperature. Under such circumstances the air cooling share will increase.

4.5 Maintenance on the Water Filter

Caution The fan cover can, with the pump at standstill, be opened for running maintenance on the water filter (see Fig. 15).

The water filter (Fig. 16) should be subjected to maintenance in **regular** intervals. The cleaning intervals will depend on the quality of the cooling water. However, the filter screen (Fig. 16) should be replaced at least once a year.

For this it is necessary to unscrew the closure screw and replace the filter screen and the O-ring.

Caution When installing, ensure corresponding leak tightness.

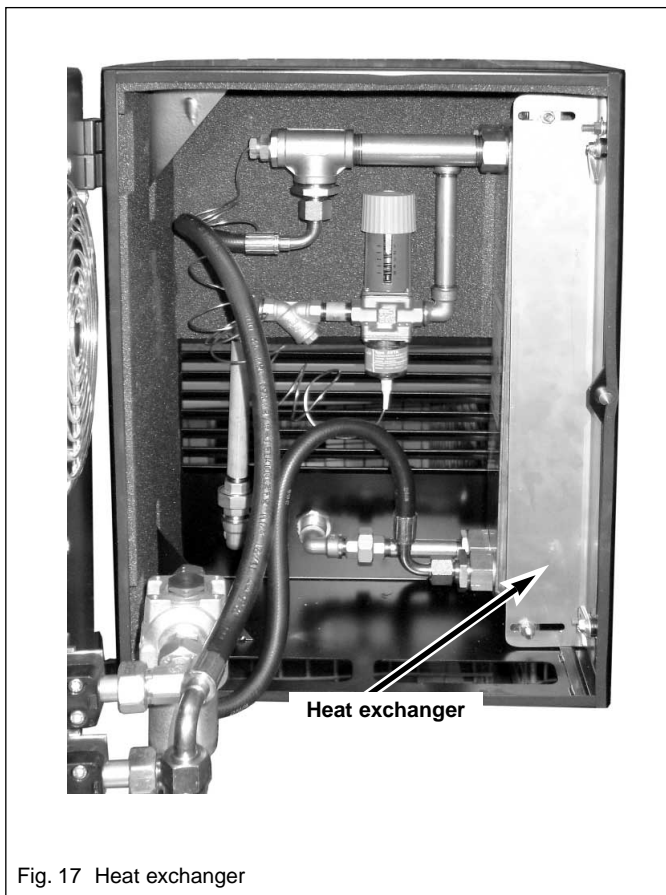

Fig. 17 Heat exchanger

4.6 Maintenance on the Heat Exchanger

When experiencing a cooling performance, either the cooling water throughput is too low or the water supply temperature is too high. In these cases the oil temperature will increase. The oil temperature can be read off at the display of the SP-Guard.

Calcination of the heat exchanger will also result in a reduced cooling performance. In such a case the heat exchanger will have to be replaced.

Caution The heat exchanger must not be treated with a decalcifying agent.

Note The heat exchanger must be replaced after 43,000 operating hours.

4.7 Transportation and Maintaining in Stock

When transporting the ScrewLine SP 630 F the following must be observed:

- Open the fan cover (Fig. 15).
- Fully open the thermostat valve (Fig. 16); position below 1.
- Disassemble the water connections on the side of the customer and blowout the heat exchanger with compressed air.
- Again lock the fan cover in place.

If the Screwline SP 630 F is stored in an environment which is not free of frost, the heat exchanger must also be emptied.

3.8 Table / Maintenance and Servicing Work ScrewLine SP 630 F

| Maintenance and Service ScrewLine SP 630 F | Periodical / If required | | Carried out by | | Where to do | | Materials | | Note |
|--|--------------------------|----------|----------------|---|---|---------|-----------|--|---|
| | Annual | 18,000 h | 43,000 h | Operator | Operator | On site | On site | On site | |
| Checking and draining the exhaust silencer (optional accessory) | x | | | Operator | On site | | | | Refer to operating Instruction exhaust silencer |
| Cleaning the dust filter (optional accessory) | x | | | Operator | On site | | | | Refer to operating Instruction dust filter |
| Checking and cleaning the gas ballast valve (optional accessory) | x | | | Operator | On site | | | | Refer to operating Instruction gas ballast valve |
| Checking the oil level | x | | | Operator | On site | | | | Refer to operating Instruction ScrewLine - Chapter 3 Maintenance |
| Checking, replacing the filter for water cooling system | x | x | x | Operator | On site | | | EK 110000813 | Refer to operating Instruction ScrewLine - Chapter 3 Maintenance |
| Oil change and oil filter change | x | x | x | Operator or Leybold Field-Service | On site | | | EK 110000792 EK 110000813 | Refer to operating Instruction ScrewLine - Chapter 3 Maintenance |
| Inspection and cleaning the screw rotors | x | x | x | Trained Operator or Leybold Field-Service | On site | | | EK 110000793 | Required training offered by Leybold Vacuum ¹⁾ |
| Change of axial bearings | | x | x | Trained Operator or Leybold Field-Service | On site | | | EK 110000792 EK 110000793 EK 110000794 EK 110000813 | Required training offered by Leybold Vacuum ¹⁾ |
| Full-Service | | | x | Leybold Service | Authorised Service Center¹⁾ | | | | Full-Service carried out by authorised Leybold Service Center only |

¹⁾ refer to service-addresses

5 Troubleshooting

| Fault | Possible cause | Remedy | Repair |
|---|---|--|--|
| Pump does not start up. | Defective wiring. Motor protection switch not set up properly (applies only to three-phase motors) Supply voltage does not match the motor's rating. Motor defective. Pump seized. Links in the motor's junction box. | Check the wiring and have it repaired. Properly set up the motor protection switch. Have the pump repaired. Set the links as detailed in the wiring diagram. | Electrician Electrician Service Service Service Electrician |
| Pump does not attain its ultimate pressure. | Method of measurement or measuring equipment is unsuitable. External leak. Degassing due to water residues. Pump much contaminated by the process. Dirt in the exhaust line. Caution If oil-sealed pumps were used before, please only use cleaned and oil-free pipes. Exhaust pressure too high (Pabs. => 1,200 mbar). Pump's temperature is too low. | Use the correct method of measurement and measuring instrument. Measure the pressure direct at the pump's intake flange. Have the pump repaired. Operate the pump for at least 30 minutes with gas ballast on. Check the process. Disassemble and clean the pump. Clean the exhaust line and then operate the pump with gas ballast on. Optimise the cross section of the exhaust line - If required clean the exhaust line. Let the pump run warm (> 1 h). | - Service Service Service |
| Pumping speed of the pump is too low. | Inlet screen in the intake port is clogged. Connecting lines too narrow or too long. Exhaust back pressure too high. Nominal pumping speed too low. | Clean the inlet screen. Install sufficiently wide lines which are as short as possible. Precaution: install a dust filter in the intake line. Replace the filter element. Optimise the cross section of the exhaust line. Check the application. | |
| After switching the pump off under vacuum, the pressure in the system increases too fast. | Leak in the system. No valve for blocking the inlet port (anti-suckback valve) has been fitted which automatically closes upon standstill of the pump. Valve at the intake not closed. | Check the system. Fit a valve to block the intake line. Close the valve at the intake port. | |
| Pumps gets hotter than previously observed. | Flow of cooling air is obstructed. Ambient temperature is too high. Process gas is too hot. Deviating nominal supply voltage. Exhaust pressure is too high. Oil cooler has accumulated dirt. | Correctly install the pump. Correctly install the pump (< 40 °C). Change the process, cool as required, max. inlet temp. 50 °C. Check motor rating and mains voltage. Optimise the cross section of the exhaust line. Clean the oil cooler with compressed air. | Electrician |
| The pump is extremely loud. | Bearing damaged. Thick particle deposits. Silencer defective. High gas throughput with the exhaust line open, no silencer. | Have the pump repaired. Clean the pump resp. run maintenance. Have the silencer repaired. Install an exhaust line or a silencer. | Service Service |
| Oil film in the junction box | Oil ingress after longer periods of utilisation. | No action is required. | |



The products described fulfil the requirements of
- Machinery Directive 98/37/EEC
- Low Voltage Directive 73/23/EEC
- Electromagnetic Compatibility Directive 89/336/EEC

EG-Konformitätserklärung

Hiermit erklären wir, die Leybold Vakuum GmbH, dass die nachfolgend bezeichneten Produkte in der von uns in Verkehr gebrachten Ausführung den einschlägigen EG-Richtlinien entsprechen.

Bei einer nicht mit uns abgestimmten Änderung eines Produktes verliert diese Erklärung ihre Gültigkeit.

Die Produkte entsprechen folgenden Richtlinien:

- EG-Maschinenrichtlinie (98/37/EG)
- EG-Niederspannungsrichtlinie (73/23/EWG)
- EG-Richtlinie Elektromagnetische Verträglichkeit (89/336/EWG), (91/263/EWG), (92/31/EWG) und (93/68/EWG)

Bezeichnung der Produkte:

Trockenverdichtende Schraubenpumpe

Typ: Screw Line SP 630

Katalog-Nr
117 001, 117 002
117 003, 117 004
117 005, 117 006
117 007, 117 008
117 009, 117 010
117 011, 117 012

Angewandte harmonisierte Normen:

- EN 1012 - 2, 1996; Sicherheitsanforderungen an Kompressoren und Vakuumpumpen Teil 2: Vakuumpumpen
- EN 292, 1991; Sicherheit von Maschinen; Grundbegriffe, allgem. Gestaltungsgrundsätze; Teil 1: Grundsätzliche Terminologie, Methodik;
- EN 292, 1995; Sicherheit von Maschinen; Grundbegriffe, allgemeine Gestaltungsgrundsätze; Teil 2: Technische Leitsätze und Spezifikationen
- EN 61000-6-2 und -6-4 (Industriebereich), alle 2001, Elektromagnetische Verträglichkeit (EMV)
- EN 61010-1: 2001; Sicherheitsbestimmungen für MSR und Laborgeräte. Allgemeine Anforderungen.
- EN 61326: 1997; Elektrische Betriebsmittel für Leittechnik und Laboreinsatz – EMV Anforderungen

Chemtech Scientific provides access to this content as a courtesy.
We do not own the content contained in this document.
All rights and credit go directly to its rightful owners.
www.chemtechsci.com
Call us at: 484-424-9415

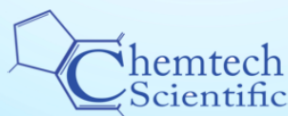



The products described fulfil the requirements of
- Machinery Directive 98/37/EEC
- Low Voltage Directive 73/23/EEC
- Electromagnetic Compatibility Directive 89/336/EEC

EG-Konformitätserklärung

Hiermit erklären wir, die Leybold Vakuum GmbH, dass die nachfolgend bezeichneten Produkte in der von uns in Verkehr gebrachten Ausführung den einschlägigen EG-Richtlinien entsprechen.

Bei einer nicht mit uns abgestimmten Änderung eines Produktes verliert diese Erklärung ihre Gültigkeit.

Die Produkte entsprechen folgenden Richtlinien:

- EG-Maschinenrichtlinie (98/37/EG)
- EG-Niederspannungsrichtlinie (73/23/EWG)
- EG-Richtlinie Elektromagnetische Verträglichkeit (89/336/EWG), (91/263/EWG), (92/31/EWG) und (93/68/EWG)

Bezeichnung der Produkte:

Trockenverdichtende Schraubenpumpe

Typ: **Screw Line SP 630 F**

Katalog-Nr **117 105, 117 106**

Angewandte harmonisierte Normen:

- EN 1012 - 2, 1996; Sicherheitsanforderungen an Kompressoren und Vakuumpumpen Teil 2: Vakuumpumpen
- EN 61010-1: 2001; Sicherheitsbestimmungen für MSR und Laborgeräte. Allgemeine Anforderungen.
- EN 61326: 1997; Elektrische Betriebsmittel für Leittechnik und Laboreinsatz – EMV Anforderungen

Chemtech Scientific provides access to this content as a courtesy.
We do not own the content contained in this document.
All rights and credit go directly to its rightful owners.
www.chemtechsci.com
Call us at: 484-424-9415





Declaration of Contamination of Compressors, Vacuum Pumps and Components

The repair and / or servicing of compressors, vacuum pumps and components will be carried out only if a correctly completed declaration has been submitted. Non-completion will result in delay. The manufacturer can refuse to accept any equipment without a declaration. A separate declaration has to be completed for every single component.

This declaration may be completed and signed only by authorised and qualified staff.

Customer/Dep./Institute: _____
Address: _____

Person to contact: _____
Phone: _____ **Fax:** _____
Order number of customer: _____

Reason for returning the item/s

A. Description of the equipment (machine or component)

Type: _____
Catalogue number: _____
Serial number: _____
Type of oil used: _____

Ancillary equipment

B. Condition of the equipment (machine or component)

| | Yes | No | Not known |
|------------------------------------|--------------------------|--------------------------|--------------------------|
| 1. Has the equipment been used | <input type="checkbox"/> | <input type="checkbox"/> | <input type="checkbox"/> |
| 2. Drained (product/service fluid) | <input type="checkbox"/> | <input type="checkbox"/> | <input type="checkbox"/> |
| 3. All openings sealed airtight | <input type="checkbox"/> | <input type="checkbox"/> | <input type="checkbox"/> |
| 4. Purged: | <input type="checkbox"/> | <input type="checkbox"/> | <input type="checkbox"/> |
| Cleaning agent: _____ | | | |
| Method of cleaning: _____ | | | |

C. Description of processes / substances (Please fill in absolutely)

1. What substances have come into contact with the equipment:
Trade name, chemical name of service fluids and substances processed, properties of the substances according to safety data sheet (toxic, inflammable, corrosive, radioactive)

| | Trade name: | Chemical name: | Properties: |
|----|-------------|----------------|-------------|
| a) | | | |
| b) | | | |
| c) | | | |
| d) | | | |

2. Are these substances harmful? Yes No Not known

3. Dangerous decomposition products when thermally loaded Yes No Not known

Which: _____

Components contaminated by micro biological, explosive or radioactive products will not be accepted without written evidence of decontamination.

D. Legally binding declaration

I/we hereby declare that the information supplied on this form is accurate and sufficient to judge any contamination level.

Name of authorised person (block letters): _____

date

signature of authorised person

firm stamp