

Chemtech Scientific provides access to this content as a courtesy.  
We do not own the content contained in this document.  
All rights and credit go directly to its rightful owners.  
[www.chemtechsci.com](http://www.chemtechsci.com)  
Call us at: 484-424-9415



# Oil-free Vacuum Pump

SCROLLVAC SC 5 D

SC 15 D

SC 30 D

SC 60 D

Operating Instructions GA01423\_002\_A2

Part Nos.

133 000

133 001

133 002

133 003

133 004

133 008

133 100

133 101

133 102



# Table of contents

	Page
<b>General Safety Information</b>	<b>3</b>
<b>1 Description</b>	<b>7</b>
1.1 Design and Operation	7
1.2 Component Designations of the Individual Pump Types	9
1.2.1 Ordering Information	9
1.3 Technical Data	10
1.3.1 Motor Data	11
1.3.2 Dimensions	14
<b>2 Transport and Storage</b>	<b>17</b>
<b>3 Installation</b>	<b>18</b>
3.1 Checking the Product	18
3.2 Ambient Conditions	20
3.3 Setting up the Pump	21
3.4 Electrical Connections	22
3.4.1 Single-phase Motors	22
3.4.2 Three-phase Motors	25
3.5 Connection to the Vacuum System	28
<b>4 Operation</b>	<b>29</b>
4.1 Start-up	30
4.2 Pumping	31
4.3 Purge Gas Operation (pumping of vapours)	31
4.4 Shutdown	33
<b>5 Maintenance</b>	<b>34</b>
5.1 Table - Maintenance	36
5.2 Oerlikon Leybold Vacuum Service	37
5.3 Waste Disposal	37
<b>6 Troubleshooting</b>	<b>38</b>
<b>7 Spare Parts</b>	<b>39</b>
<b>EC Conformance Declaration</b>	<b>40</b>
<b>Declaration of Contamination</b>	<b>42</b>

---

## Figures

The references to diagrams, e.g. (4/1/2) consist of Chapter No., consecutive Fig. No. within the chapter and the Item No. in the figure in that order.

We reserve the right to modify the design and the specified data. The illustrations are not binding

# Safety information

## General Safety Information

Indicates procedures that must be strictly observed to prevent hazards to persons.

Indicates procedures that must be strictly observed to prevent damage to, or destruction of the appliance.

The Oerlikon Leybold Vacuum oil-free scroll vacuum pumps are designed for safe and efficient operation when used properly and in accordance with this manual. It is the responsibility of the user to carefully read and strictly observe all safety precautions described in this section and throughout the manual. **This product must be operated and maintained by trained personnel only.** Consult local, state, and national agencies regarding specific requirements and regulations. Address any further safety, operation and/or maintenance questions to your nearest Oerlikon Leybold Vacuum office.

### Failure to observe the following precautions could result in serious personal injury.

Never pump toxic, explosive, flammable, corrosive gases, chemicals, solvents or powders. Flowing substances, explosion or fire can cause bodily injury.

Install the pump in an area without explosive or flammable substances. Otherwise, it can cause explosion or fire.

Wiring must be done by a qualified electrician. Otherwise there is the risk of suffering an electric shock.

Prevent short-circuits with a ground fault circuit interruptor (GFCI) of proper capacity.

Failure to do so can result in electric shock or fire.

Ask a specialist to perform repairs. Otherwise there exists the risk that the pump may fail, is damaged or its service life is severely reduced. Trained customers may perform maintenance themselves.

Be sure to install a main disconnect switch. Failure to do so can result in damage, fire, or injury.

Be sure to disconnect the electric source before changing the wiring or before an inspection. Failure to do so can result in electric shock or damage by the rotating fan.

---

### Warning



---

### Caution

---

---

### Warning



---

### Disconnect from mains power



# Safety information

## Ensure grounding



Ensure proper grounding of the pump. Otherwise there exists the risk of suffering an electric shock or igniting a fire.

## Do not touch



Never put fingers or foreign matter into the pump's inlet or the clearance of fan blades. If done, it can cause injury.

## Avoid moisture



Install in an area which is not exposed to moisture such as rain or steam. Exposure to moisture can cause electric shock.

## Do not alter



Never alter the equipment. Modifications can damage the equipment or shorten its service life.

Be sure to check wiring diagram before connecting a power supply. Failure to do so can result in damage.

## With a thermal protector



Pumps with single-phase motors have an internal thermal protector. These motors restart without warning after the protector trips back. Be sure to switch off the electric power before maintenance or inspection. Failure to do so can result in electric shock or bodily injury by rotating objects.

## Use at designated temperature

Use at ambient temperatures of 5 - 40 °C (during operation). Operating outside of this range can cause damage or shorten service life.

**Always** operate the pump with the fan and terminal covers in place.

**Always** operate the single-phase pumps with the capacitor cover in place.

## Conduct periodic maintenance

Conduct periodic maintenance and inspections. Failure to do so can cause damage or reduced service life.



Do the maintenance after the pump has fully cooled down. Performing maintenance on a hot pump can cause burns.

## Start or stop after closing isolation valve

Be sure to close the isolation valve between pump and vacuum system (chamber) during startup and shutdown. If this valve is open, debris attached to the inside of pump can be drawn back into the vacuum chamber.

# Safety information

**SC 5 D**  
**Single-phase**

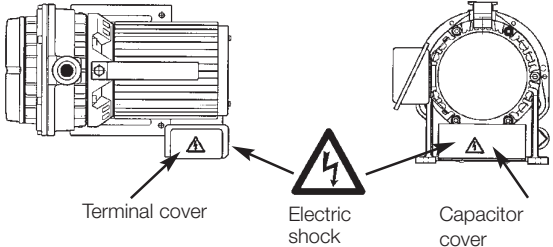

**SC 15 D**  
**Single-phase**

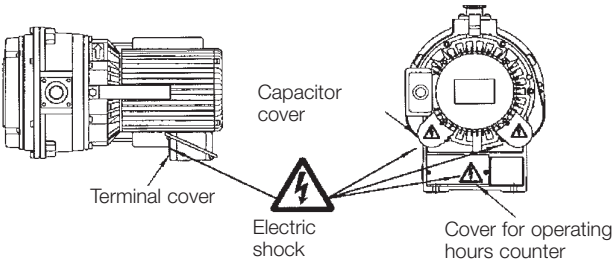

**SC 15 D**  
**Three-phase**

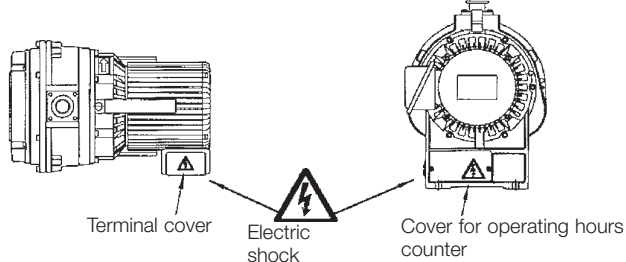

Always keep warning stickers clean. If they become dirty or lost, replace them with new ones.  
If you need stickers, contact Oerlikon Leybold Vacuum.

Fig. 0.1 Placement of the warning stickers

# Safety information

SC 30 D  
Single-phase

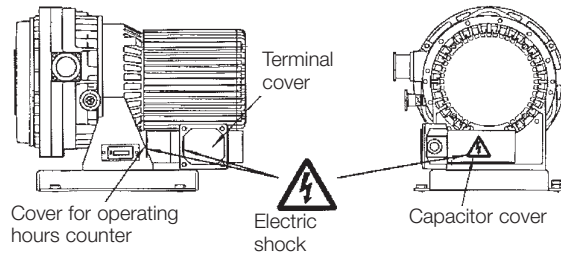

SC 30 D  
Three-phase

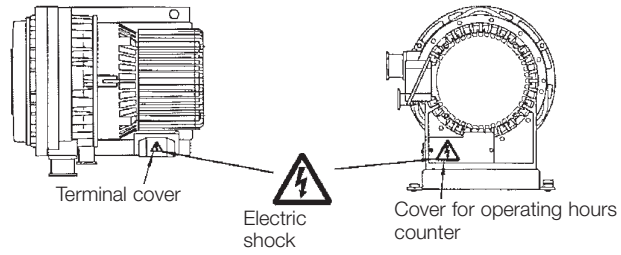

SC 60 D  
Three-phase

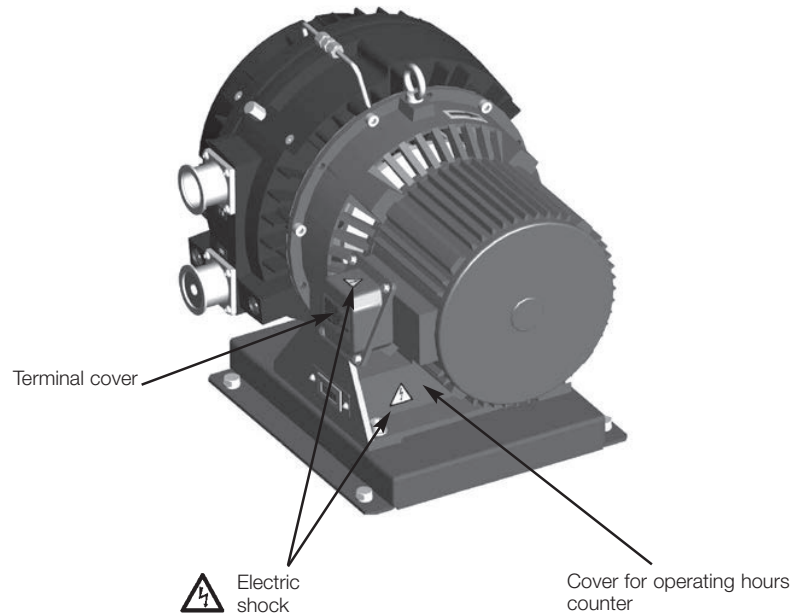

Always keep warning stickers clean. If they become dirty or lost, replace them with new ones.  
If you need stickers, contact Oerlikon Leybold Vacuum.

Fig. 0.2 Placement of the warning stickers

## 1 Description

### 1.1 Design and Operation

The SCROLLVAC vacuum pumps are oil-free vacuum pumps. Each SCROLLVAC consists of two Archimedes spirals offset within each other by 180°. Thus several crescent-shaped pockets of different sizes are created. With the aid of an eccentric drive, the second spiral orbits about the fixed spiral thereby reducing, respectively increasing the volume of the pockets whereby the gases are conveyed from outside to inside thereby being compressed.

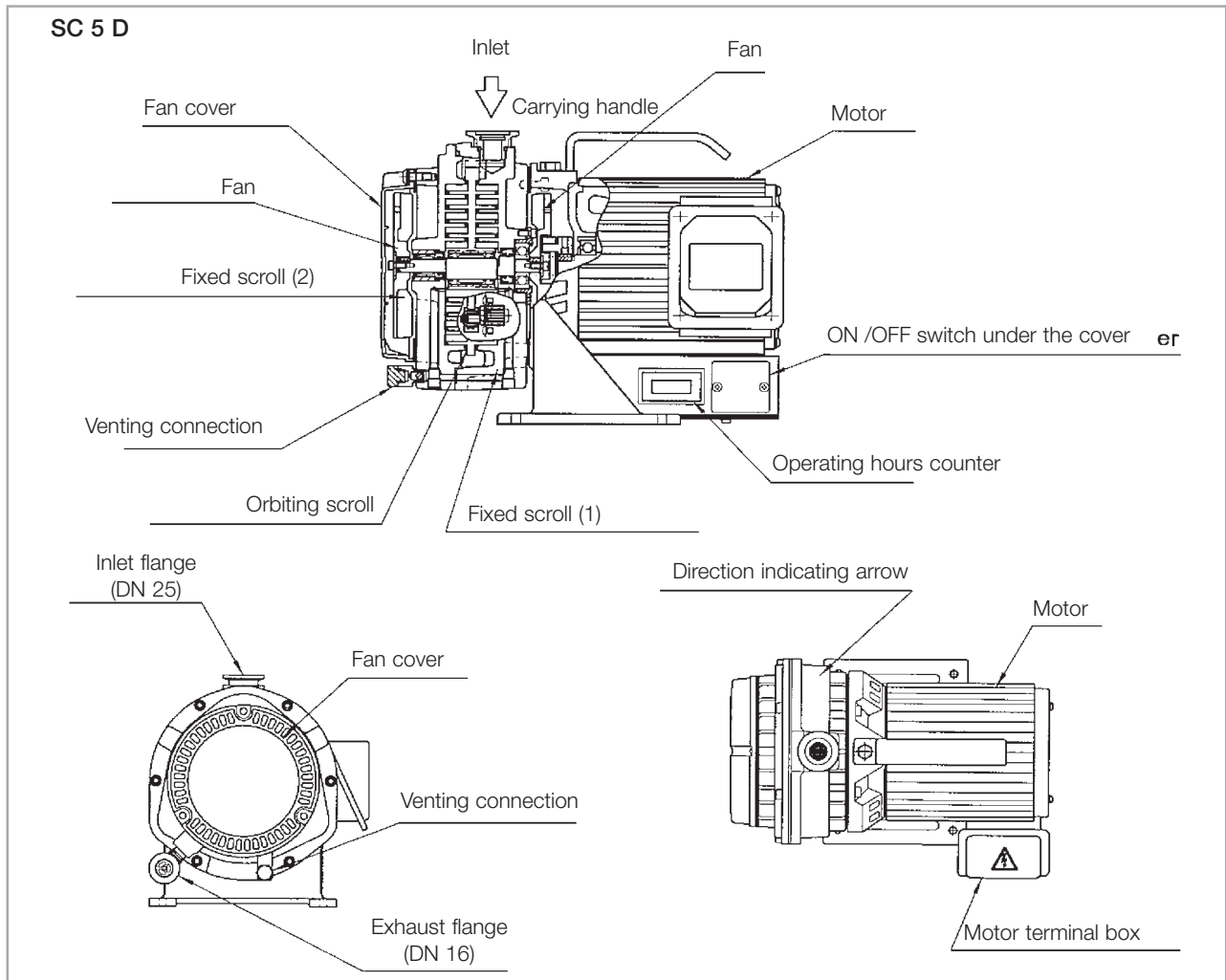

Fig. 1.1 Component designations (SC 5 D)

# Description

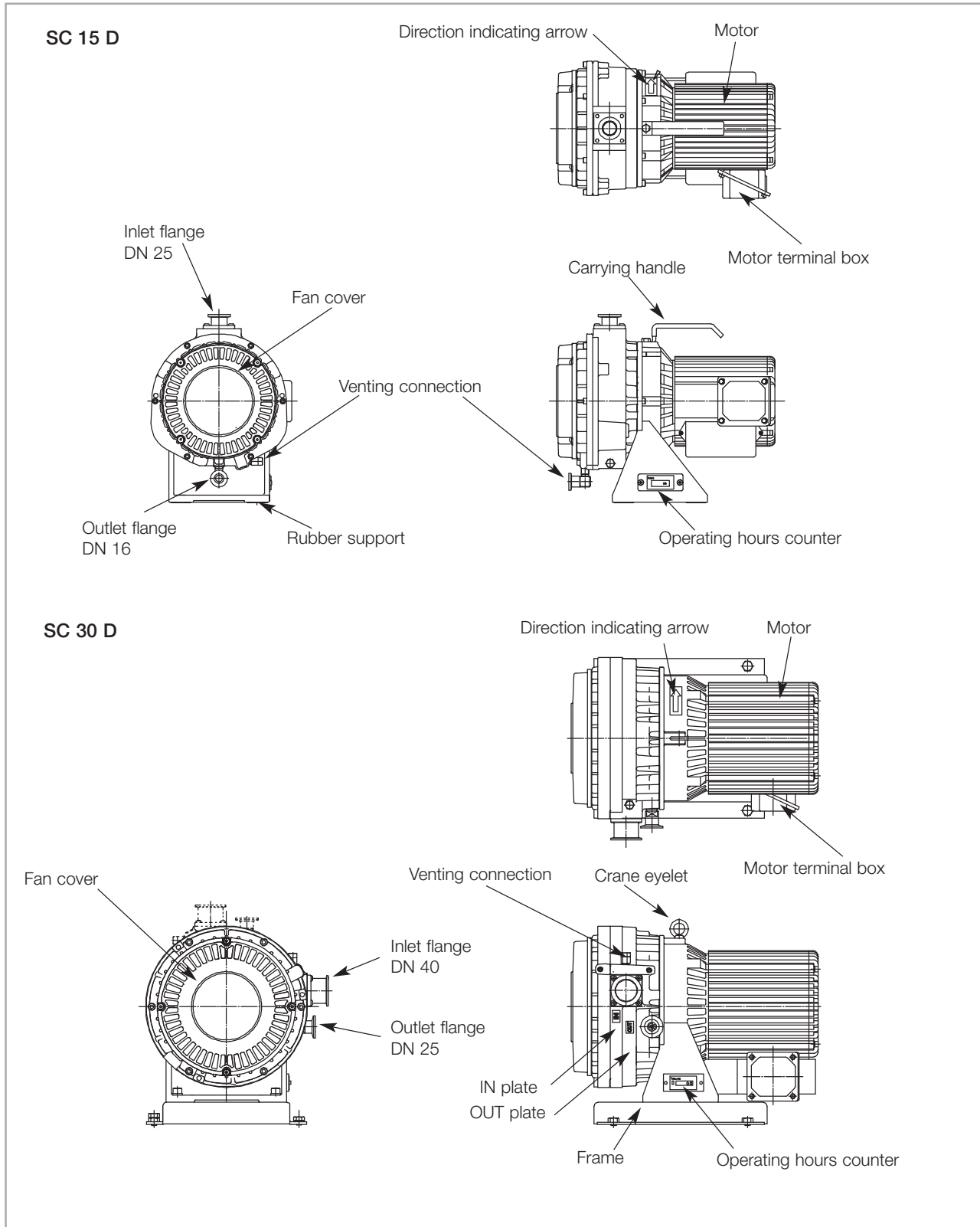

Fig. 1.2 Component designations (SC 15 D/30 D)



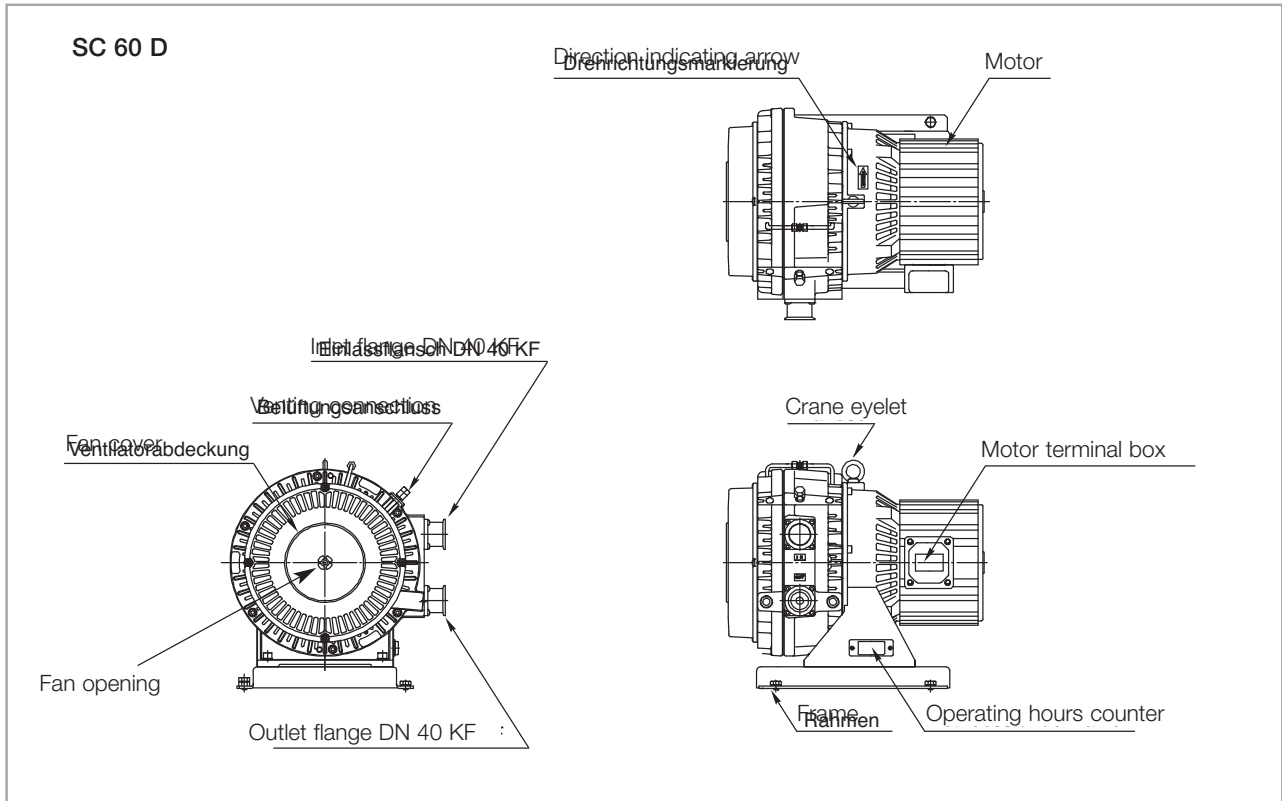

Fig. 1.3 Component designations (SC 60 D)

## 1.2 Component Designations of the Individual Pump Types

### 1.2.1 Ordering Information

SC 5 D, single-phase motor, cable with Schuko plug  
 SC 15 D, single-phase motor, cable with Schuko plug  
 SC 30 D, single-phase motor, cable with Schuko plug

#### Part No.

133 000  
 133 001  
 133 002

SC 15 D, three-phase motor  
 SC 30 D, three-phase motor  
 SC 60 D, three-phase motor

133 003  
 133 004  
 133 008

SC 5 D, single-phase motor, cable with NEMA plug  
 SC 15 D, single-phase motor, cable with NEMA plug  
 SC 30 D, single-phase motor, cable with NEMA plug

133 100  
 133 101  
 133 102

# Description

## 1.3 Technical Data

Model		SC 5 D		SC 15 D		SC 30 D		SC 60 D	
		50 Hz	60 Hz	50 Hz	60 Hz	50 Hz	60 Hz	50 Hz	60 Hz
Displacement (swept volume)	l · min <sup>-1</sup>	90	108	250	300	500	600	1000	1200
	m <sup>3</sup> · h <sup>-1</sup>	5	6,48	15	18	30	36	60	72
	cfm	3.1	3.8	8.8	10.6	17.6	21.2	35.3	42.3
Pumping speed <sup>1</sup>	l · min <sup>-1</sup>	80	93	210	230	420	500	880	1020
	m <sup>3</sup> · h <sup>-1</sup>	4,8	6,2	13,6	16,4	26,3	31,5	52	62
	cfm	2.8	3.6	8	9.6	15.4	18.5	31.0	36.0
Ultimate pressure	Pa	≤ 5		≤ 1.6		≤ 1.0		≤ 1.0	
	mbar	≤ 0.05		≤ 0.016		≤ 0.01		≤ 0.01	
	Torr	≤ 0.037		≤ 0.012		≤ 0.0075		≤ 0.0075	
Leak rate <sup>3</sup>	mbar · l · s <sup>-1</sup>	1.0 · 10 <sup>-6</sup>		1.0 · 10 <sup>-6</sup>		1.0 · 10 <sup>-6</sup>		1.0 · 10 <sup>-4</sup>	
Max. inlet pressure		Atmospheric pressure							
Ambient operating temperature range	°C	5 - 40		5 - 40		5 - 40		5 - 40	
Gas temperature at inlet	°C	max. 50		max. 50		max. 50		max. 50	
Inlet connection	DN	25		25		40		40	
Exhaust connection	DN	16		16		25		40	
Cooling		Air cooling							
Protection class	IP	20		20		20		20	
Class of equipment		Class 1							
Miscellaneous		With operating hours counter und purge gas connection							
Water vapour tolerance at 25 °C, humidity 60 %, with opened purge gas <sup>4</sup>	g/day	5		25		25		25	
	l · min <sup>-1</sup>	9		10		10		10	

## 1.3.1 Motor Data

### Motor data

### SC 5 D

Type	Single-phase induction motor / Motor 4P / totally enclosed insulation class B IP 44 thermal protector TP 212 - automatic reset type					
Power consumption	W	150				
Voltage	V	100	115	200	230	
Rated current	50 Hz	A	2.6	-	1.3	1.6
	60 Hz	A	2.1	2.2	1.1	1.1
Speed at	50 Hz	min <sup>-1</sup>	1430	-	1430	1440
	60 Hz	min <sup>-1</sup>	1730	1740	1730	1740
Noise level <sup>2</sup> at 1m dB(A) with purge gas open (ON)	≤ 52 dB(A)	≤ 57				
Direction of inlet	Vertical					
Dimensions (L x W x H)	mm	308 x 214 x 225				
Weight	kg	14				
Part numbers	133 100		133 000			

### Motor Data

### SC 15 D

Type	<b>Single ph.</b> induction motor 4P totally enclosed insulation class B / IP 44 thermal protector TP 212 automatic reset type				<b>Three-phase</b> induction motor <sup>5</sup> 4P totally enclosed insulation class B / IP 44								
Power consumption	kW	0.4				0.4							
Voltage	V	100	115	200	230	200	208	230	380	400	415	460	
Rated current	50 Hz	A	4.8	-	2.6	2.4	1.6	-	-	0.9	0.9	1.0	-
	60 Hz	A	4.8	4.3	2.8	2.4	1.9	1.9	1.8	-	-	-	1.0
Speed at	50 Hz	min <sup>-1</sup>	1440	-	1430	1450	1420	-	-	1440	1440	1440	-
	60 Hz	min <sup>-1</sup>	1710	1740	1700	1730	1660	1660	1690	-	-	-	1720
Noise level <sup>2</sup> at 1m dB(A) with purge gas open (ON)	≤ 58 dB(A)	≤ 66											
Direction of inlet	Vertical												
Dimensions (L x W x H)	mm	400 x 252 x 336				370 x 252 x 336							
Weight	kg	25				23							
Part numbers	133 101		133 001		133 003								

# Description

## Motor Data

### SC 30 D

Type			<b>Single-phase</b> induction motor 4P totally enclosed insulation class B / IP 44 thermal protector TP 212 automatic reset type				<b>Three-phase</b> induction motor <sup>5</sup> 4P totally enclosed insulation class B / IP 44						
Power consumption		kW	0.6				0.6						
Voltage		V	100	115	200	230	200	208	230	380	400	415	460
Rated current	50 Hz	A	8.5	-	4.3	3.9	2.7	-	-	1.57	1.57	1.63	-
	60 Hz	A	10	8.6	4.8	4.0	2.8	2.6	2.5	-	-	-	1.47
Speed at	50 Hz	min <sup>-1</sup>	1430	-	1430	1450	1460	-	-	1470	1470	1470	-
	60 Hz	min <sup>-1</sup>	1660	1720	1690	1730	1740	1740	1760	-	-	-	1770
Noise level <sup>2</sup> at 1m with purge gas open (ON)		dB(A)	≤ 62				≤ 60						
		dB(A)	≤ 70				≤ 68						
Direction of inlet			Horizontal (arranged at the side)										
Dimensions (L x W x H)		mm	443 x 328 x 372 (443 x 298 x 397)				372 x 328 x 372 (372 x 298 x 397)						
Weight		kg	44				38						
Part numbers			133 102	133 002	133 004								

## Motor Data

### SC 60 D

Type			<b>Three-phase</b> induction motor <sup>5</sup> 4P totally enclosed insulation class B / IP44									
Power consumption		kW	1.4									
Voltages		V	200	208	230	380	400	415	460			
Rated current	50 Hz	A	5.5	--	--	3.3	3.6	3.8	--			
	60 Hz	A	5.8	5.8	5.7	--	--	--	3.5			
Speed at	50 Hz	min <sup>-1</sup>	1460	--	--	1470	1470	1470	--			
	60 Hz	min <sup>-1</sup>	1730	1740	1750	--	--	--	1760			
Noise level <sup>2</sup> at 1m with purge gas open (ON)		dB(A)	67									
		dB(A)	74									
Direction of inlet			Horizontal (arranged at the side)									
Dimensions (L x W x H)		mm	467 x 390 x 421									
Weight		kg	60									
Part numbers			133 008									

\*Cannot operate at 115V/50 Hz, 208V/50Hz, 230V/50Hz, 460V/50 Hz, 380V/60 Hz or 415V/60 Hz

Note 1: Pumping speed remains unchanged independently of whether the purge gas inlet is open or closed

Note 2: Noise level is measured at ultimate pressure in an anechoic room

Note 3: The leak rate is measured when the pump is stopped and the purge gas supply is closed (condition as delivered)

Note 4: When the pump is delivered, the purge gas inlet is closed

Note 5: The three-phase motors do not have internal thermal protection. Be sure to install the protection from the side of the remaining system.

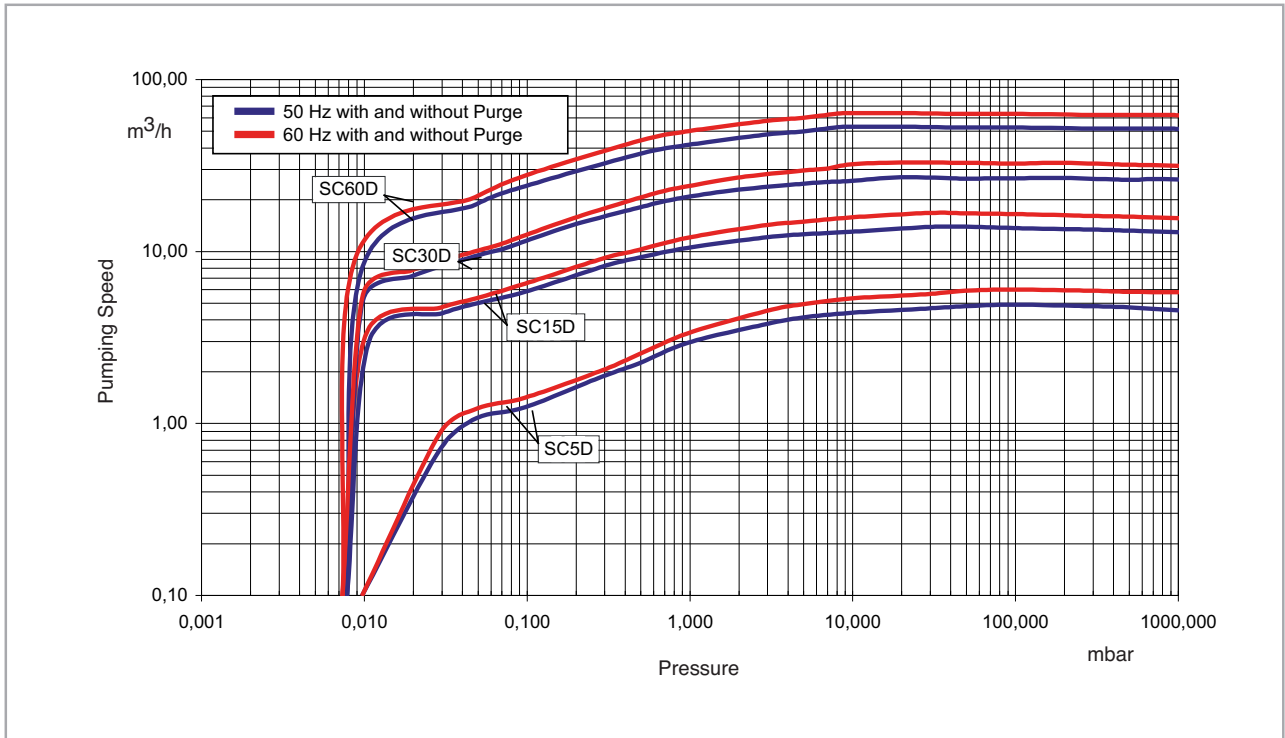

Fig. 1.4 Pumping speed curves of the SCROLLVAC SC 5 D to SC 60 D

# Description

## 1.3.2 Dimensions

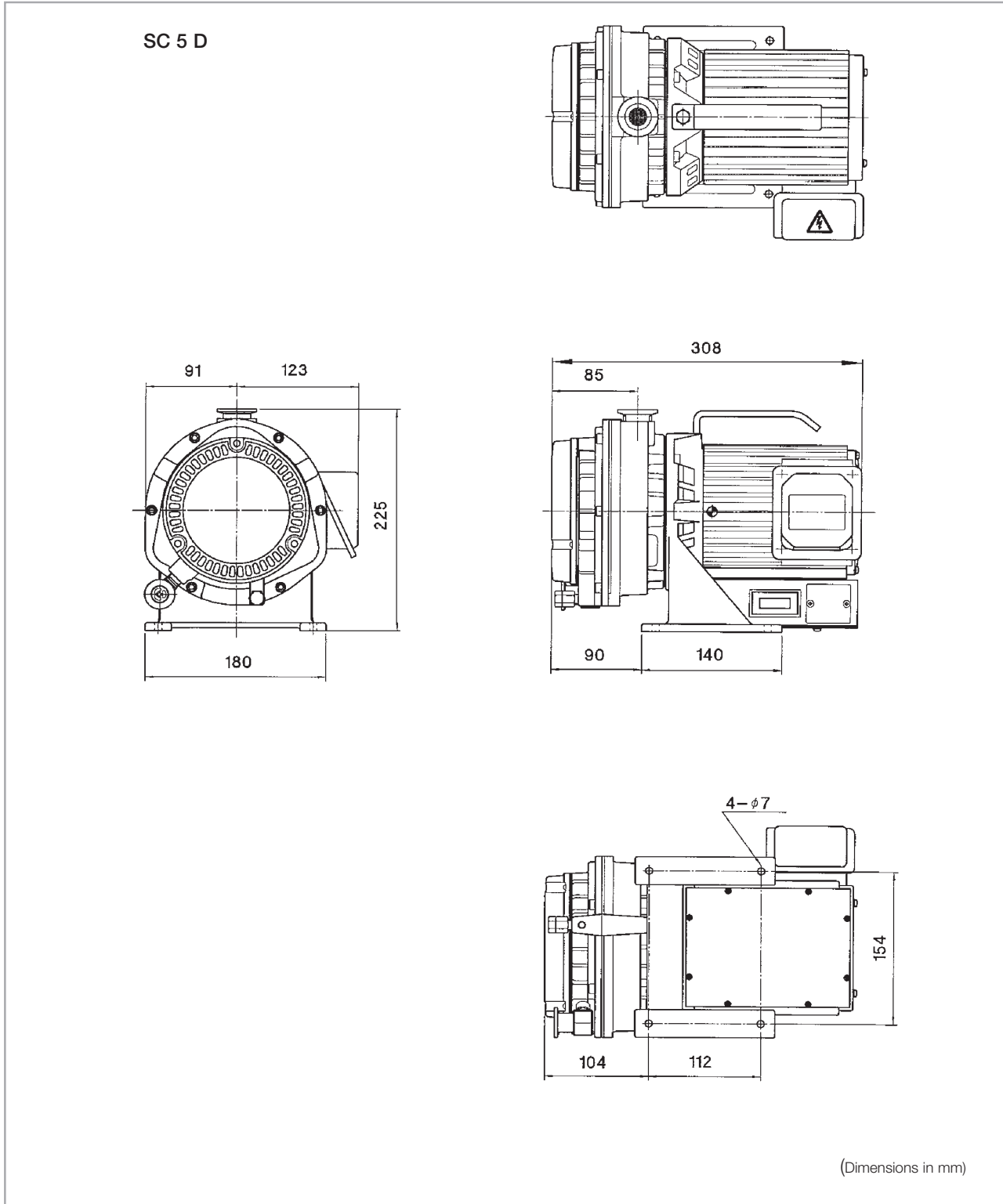
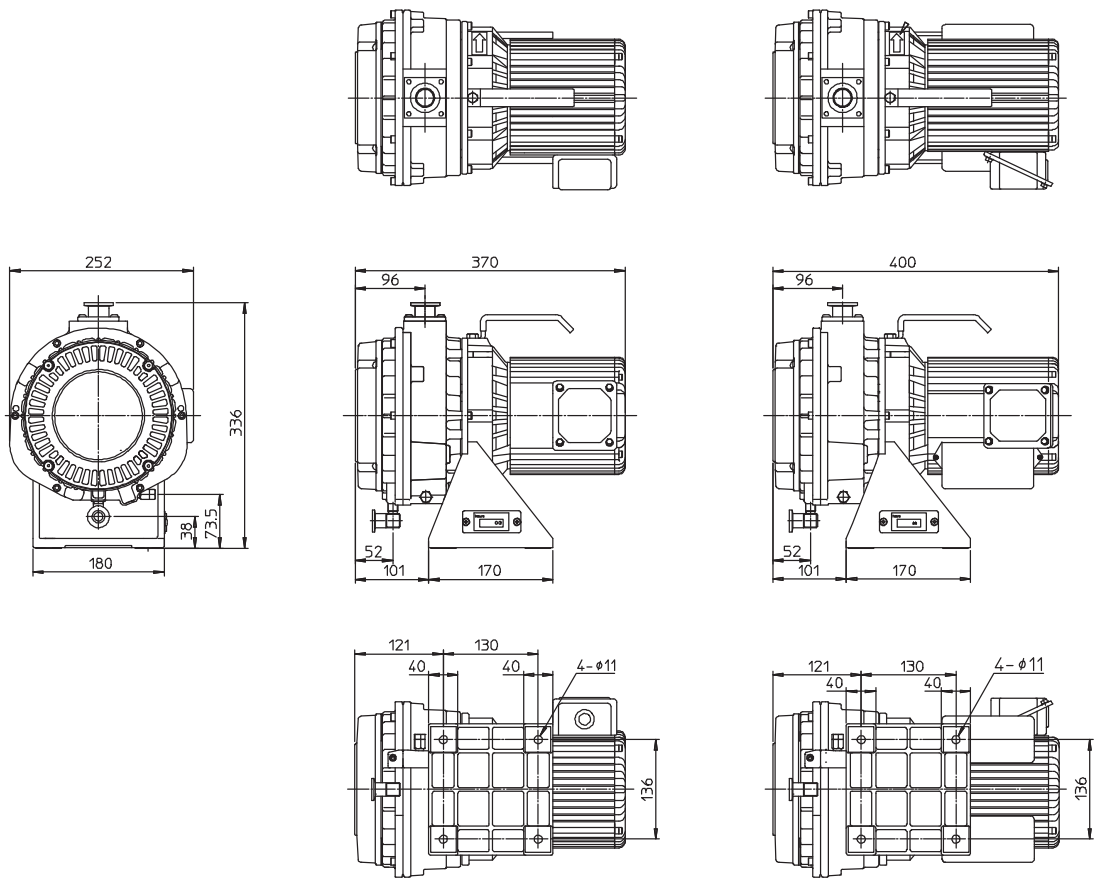

Fig. 1.5 Dimensional drawing of the SC 5 D

SC 15 D

Three-phase

Single-phase



(Dimensions in mm)

Fig. 1.6 Dimensional drawing of the SC 15 D

# Description

SC 30 D

Three-phase

Single-phase

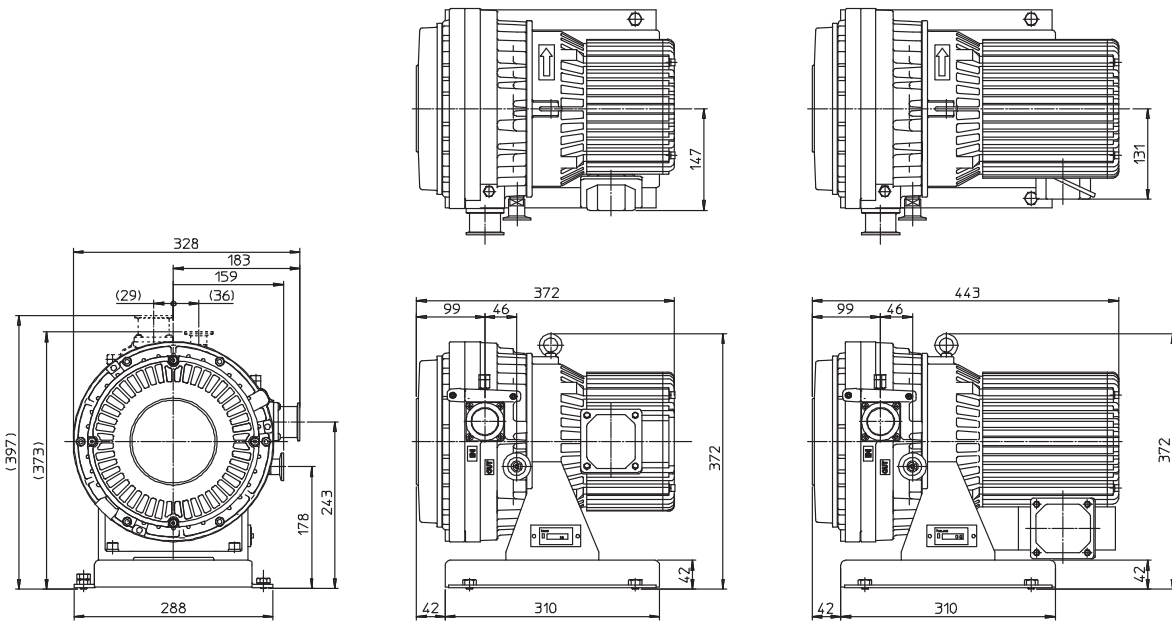

(Dimensions in mm)

Fig. 1.7 Dimensional drawing of the SC 30 D



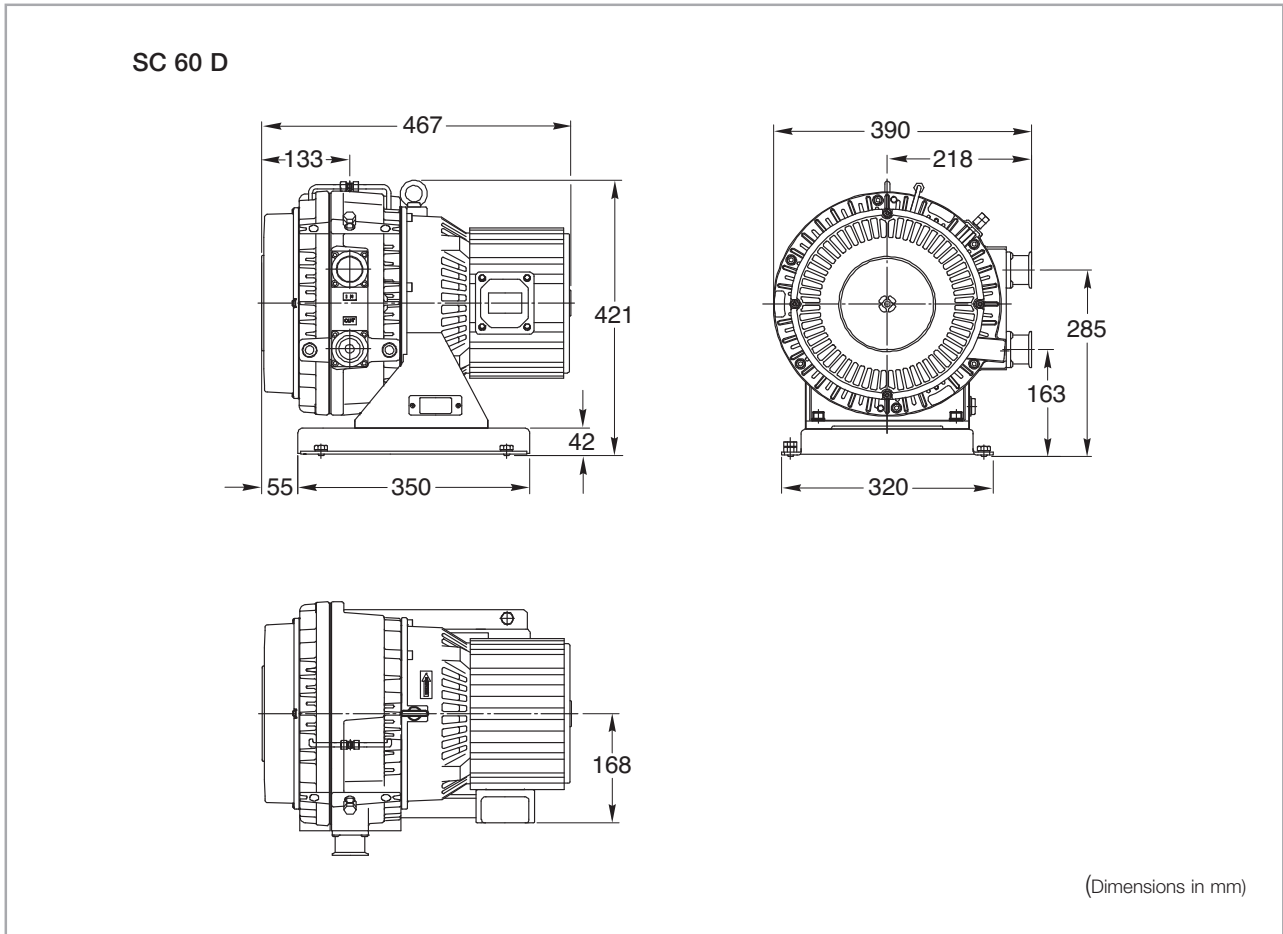

Fig. 1.8 Dimensional drawing of the SC 60 D

## 2 Transport and Storage

Lift the pump only at the provided handles, respectively crane eyelets.

Exclusively use lifting facilities with sufficient lifting capability. Never stand under the hanging pump when it is being moved.

Avoid any other orientations during transportation.

### Warning



# Installation

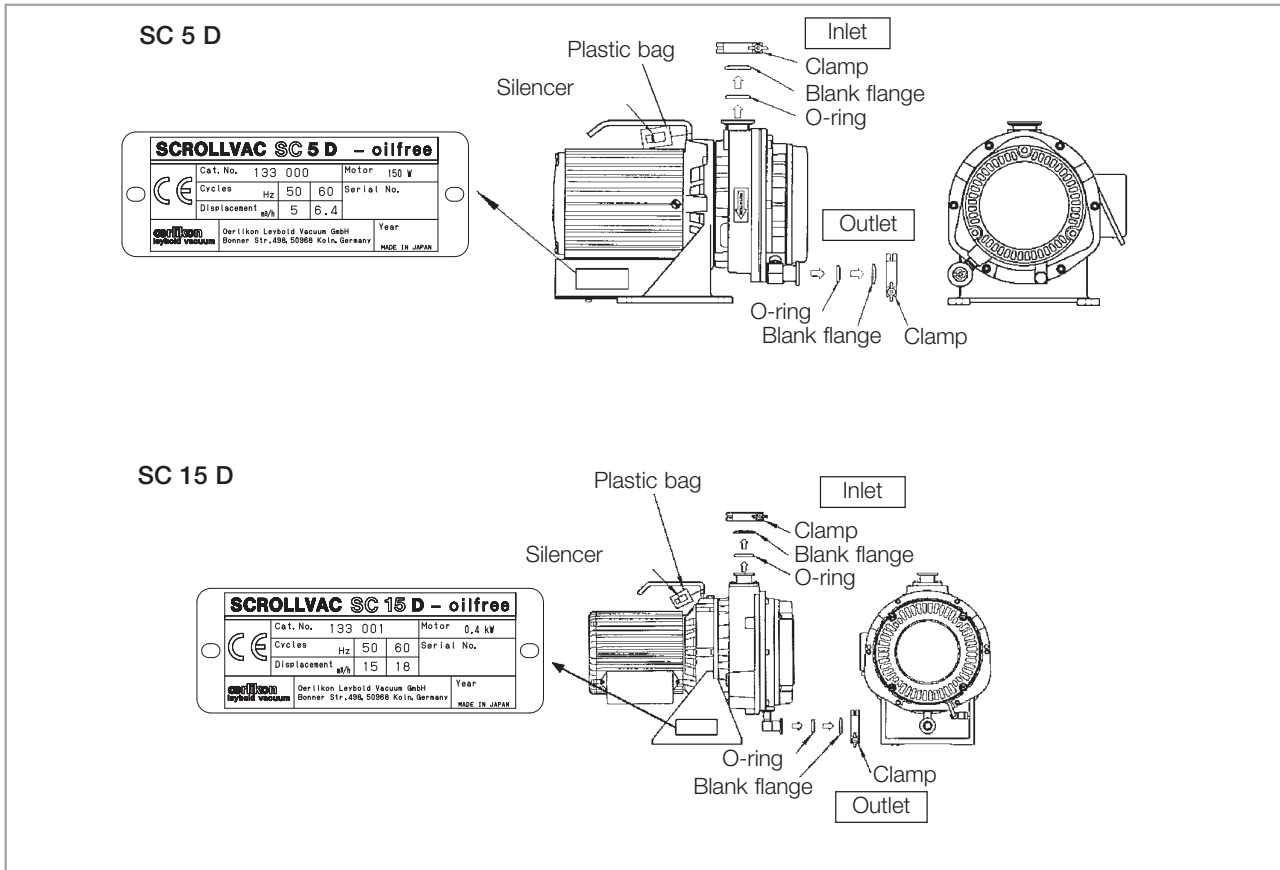

Fig. 3.1 Product check (SC 5 D / SC 15 D)

## 3 Installation

### 3.1 Checking the Product

#### Caution

Check that the package is right-side-up and then open it.

Check that model of the product is one that you ordered.

Check that there is no damage. If there is any damage, file a damage claim with the carrier.

**Remove inlet blank flange and outlet blank flange. If you operate the pump with blank flanges in place, it can cause damage.**

Check that the silencer for the purge gas inlet is present in the plastic bag.

# Installation

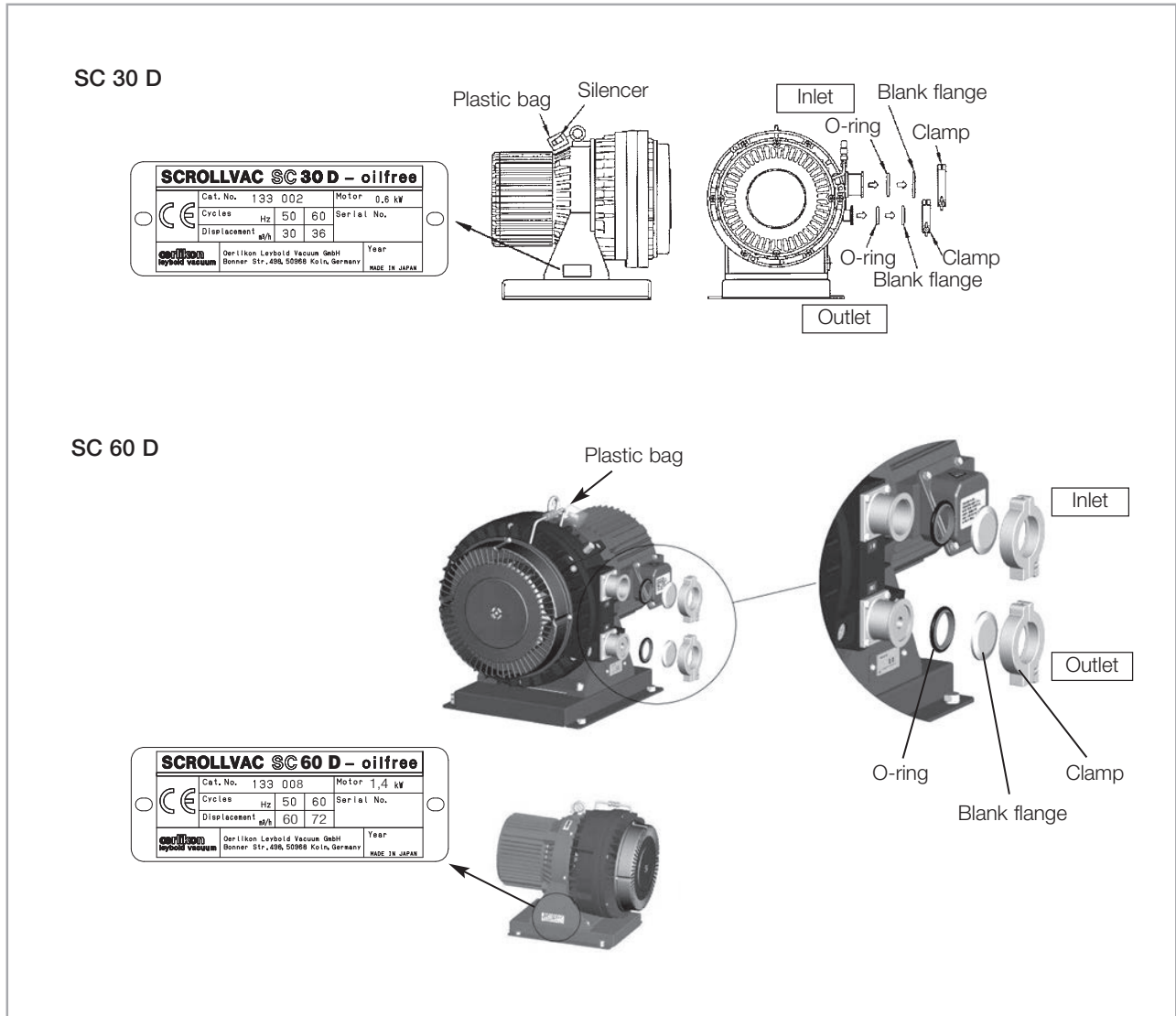

Fig. 3.2 Product check (SC 30 D / SC 60 D)

# Installation

---

**Be careful about moisture**



---

**Warning**



## 3.2 Ambient Conditions

Danger of electric shock.

Install in an area which is not exposed to moisture such as rain or steam. Moisture on electric power connections can cause bodily injury by short circuit or electric shock.

Danger of explosion and fire.

Install in an area which is not exposed to explosives, flammable gas, or other related hazards. Otherwise, the pump can cause an explosion or fire.

### Temperature

Operate at an ambient temperature of 5 °C - 40 °C. Operating outside of this ambient temperature range can cause damage, fire or failure.

Ensure proper ventilation.

Install in a well-ventilated area. Poor ventilation can cause abnormal overheating, fire or failure since the scroll pump is air-cooled.

#### Necessary ventilation air:

SC 5 D	over 2 m <sup>3</sup> · min <sup>-1</sup>
SC 15 D	over 4 m <sup>3</sup> · min <sup>-1</sup>
SC 30 D	over 8 m <sup>3</sup> · min <sup>-1</sup>
SC 60 D	over 12 m <sup>3</sup> · min <sup>-1</sup>

### Avoid dust

Install in a proper location. Install in an area which is not exposed to dust or corrosive gas. Failure to install in a proper location can result in damage or failure.

Debris can clog silencers reducing the effectiveness of the purge gas.

### Avoid direct sunlight

Install in an area which is not exposed to sunshine. Direct sunshine can cause high temperatures and failure.

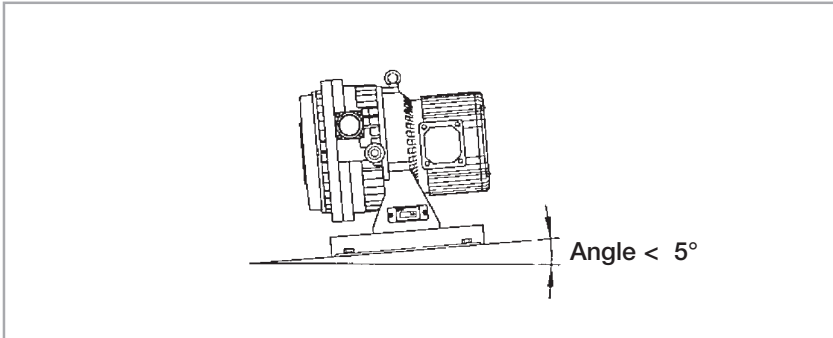

Fig. 3.3 Install on a firm, level floor

### 3.3 Setting up the Pump

The SC 5 D and SC 15 D are equipped with a carrying handle for transporting. The SC 30 D and SC 60 D are provided with a crane eyelet for transporting and placement.

Use lifting devices with sufficient carrying capacity. Never stand beneath the suspended pump while it is being moved.

The place where the pump is installed should be free of dust or steel, stone and wood dust. Moreover, the location should be free of corrosive gases.

Install the pump on a stable horizontal floor surface (sloping by no more than 5 °, see Fig. 3.3). Installing the pump on a sloping surface can cause the pump to fail.

If the floor is unstable, secure the pump by using

- 4 x dia. 7 mm holes in the pump base (SC 5 D) or
- 4 x dia. 11 mm holes in the pump base (SC 15 D) or
- 4 x holes in the pump base for M10 screws and (SC 30 D)
- 4 x holes in the pump base for M10 screws and (SC 60 D).

When not observing these installation conditions, damage may occur, or performance or service life may be impaired.

---

#### Warning



---

#### Caution

---

# Installation

## 3.4 Electrical Connections

---

Warning



Wiring must be done by a qualified electrician. Otherwise, electric shock or fire may occur.

---

Turn off power



Turn off the incoming main electrical power before wiring the pump. Failure to do so can cause injury from electric shock.

Check voltage



Check electric power and voltage before doing the wiring.

**The three-phase motor can be operated off two different mains voltages:** either 200/380V 50 Hz or 208/460 V 60 Hz.

**The single-phase motor can be operated off two different mains voltages:** either 100/200V 50 Hz or 115/208-230V 60 Hz.

Check mains voltage and wiring.

### 3.4.1 Single-phase Motors

---

Warning



Be sure to install a reliable main disconnect switch (or breaker) for emergency stop. In addition, shut off the SC 5 D by turning off the switch on the motor. Failure to do so can cause damage or fire.



The single-phase motor has an internal thermal protector. The motor restarts without warning after the protector trips back.

### CE Requirements

Min. circuit current capacity of conductor is 10 A. Max. branch circuit breaker is 15 A (industrial rated).

---

Warning



---

Protect the motor by installing the recommended breaker (refer to Table 1). Failure to do so can cause electrical shock or fire.

---

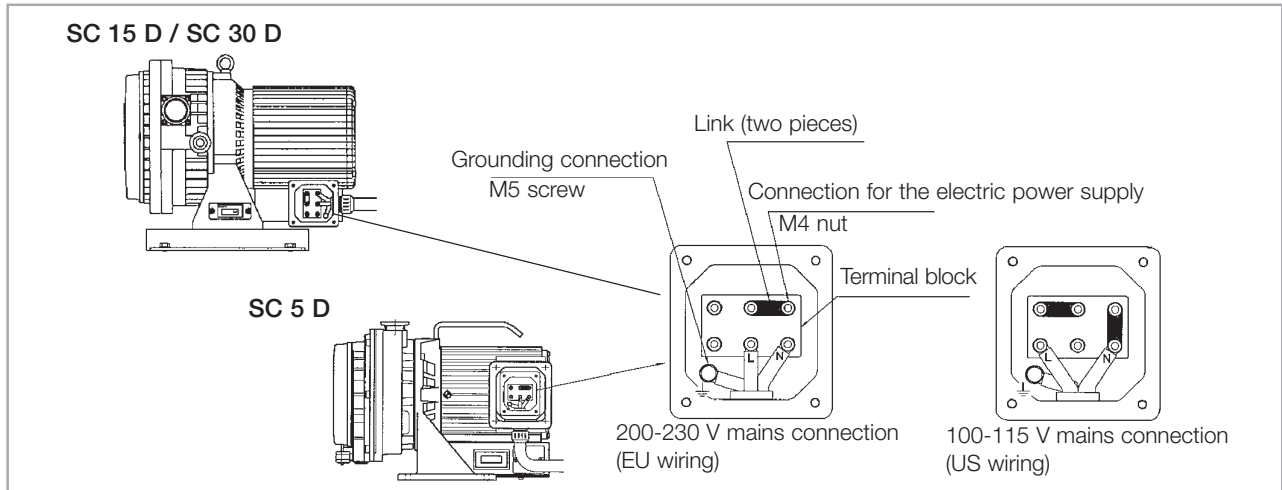

Fig. 3.4 Single-phase connection

**Table 1: Single-phase connection**

V	Hz	Rated current for the mains circuit breaker - A		
		SC 5 D	SC 15 D	SC 30 D
100	50	3.0	6.0	10.7
100	60	2.5	6.0	12.5
115	60	2.5	5.4	10.8
200	50	1.5	3.0	5.4
200	60	1.3	3.2	6.0
230	50	1.9	2.7	4.9
230	60	1.3	2.7	5.0

### Installation Involving Different Mains Voltages

This vacuum pump must be equipped with a mains circuit breaker in accordance with requirements of EN 60204-1. It is recommended to use a circuit breaker as main breaker which is suitable for isolation according to EN 60947-2 and is equipped with an operating handle which is lockable in the OFF position and complies with the other requirements of EN 60947-3.

Remove the terminal cover of the motor and check the terminal block inside. The wiring diagram is shown inside the terminal cover. You can change between 100-115 V and 200-230 V connection by changing the links. If you want to change the connection, remove the four nuts for the power terminal and change the links as illustrated in Figure 3.4. Two links are used at the 200-230 V connection. Connect the power cord through the cable-gland on the bottom side of terminal blocks.

# Installation

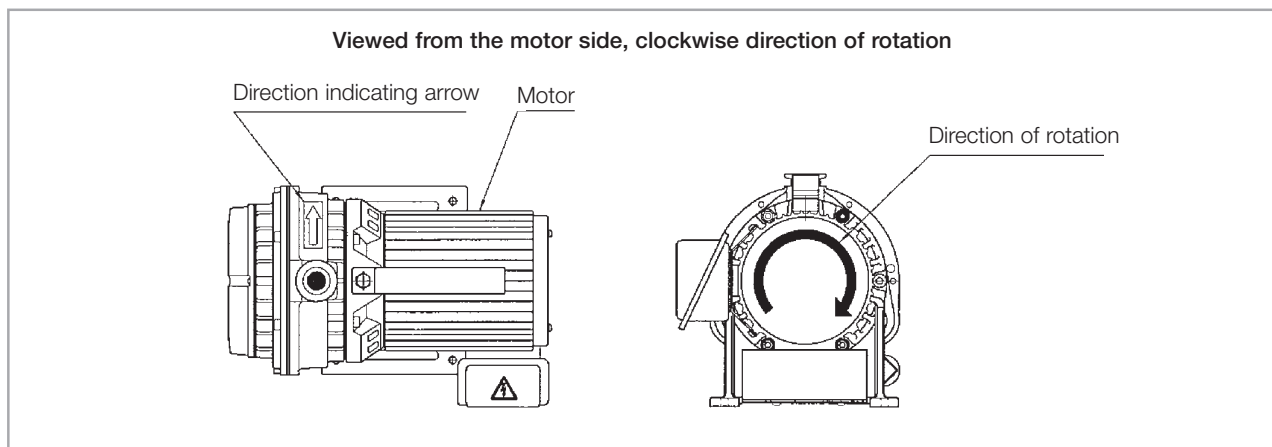

Fig. 3.5 Checking the direction of rotation after having provided the wiring

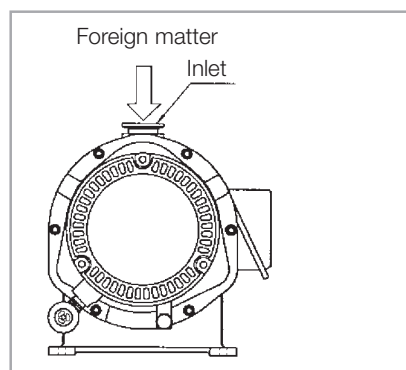

Fig. 3.6 Prevent foreign matter from entering into the pump

- Activate the emergency stop by the main disconnect switch or breaker.
- Protect the motor with a breaker.
- Use power cord and ground wire rated at greater than 10 A.
- Use round type terminal.
- Fit cable-gland.
- Connect ground wire to ground terminal.

## Warning



After each modification of power supply cable wiring a new electrical safety test has to be done according to the national rules.

Operate pump with inlet open, and check that air comes out from outlet.  
If you plan to switch the pump ON-OFF with remote control, check the pump's rotation direction before connecting it to the vacuum system.

## Caution

When checking rotation direction, avoid dropping foreign matter into inlet.  
Dropping foreign matter into the pump can cause failure.



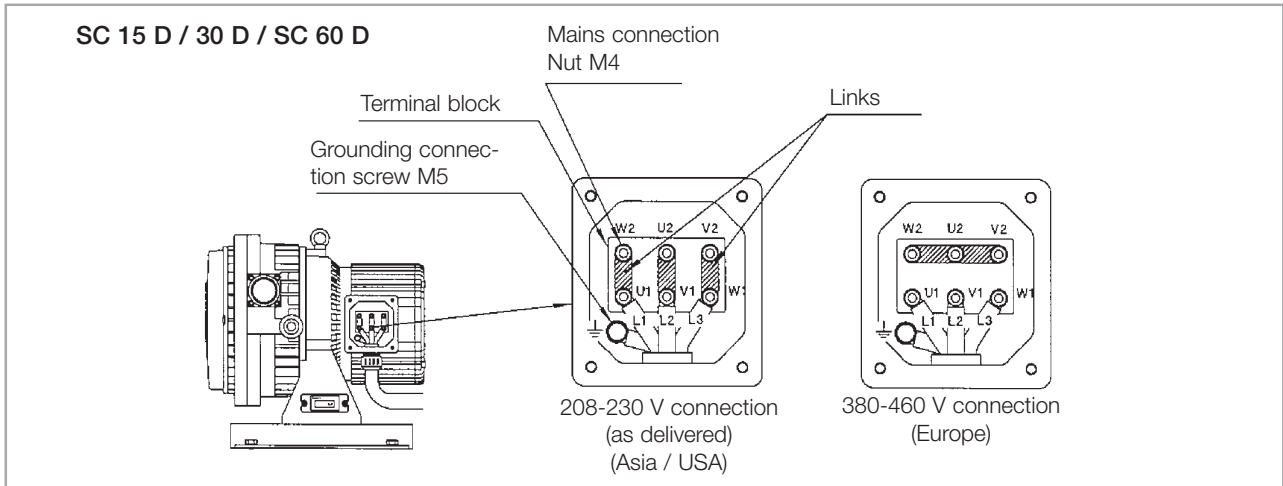

Fig. 3.7 Three-phase connection

### 3.4.2 Three-phase Motors

For SC 15 D / 30 D / 60 D only

Be sure to install a reliable main disconnect switch (or breaker) which meets the IEC standard for emergency stop. Failure to do so can cause damage or fire.

#### CE Requirements

The 3-phase motor is not protected. External protection must be provided.

- Min. circuit current capacity of the conductors is:
  - SC 15 D - 3-phase 7 A
  - SC 30 D - 3-phase 15 A
  - SC 60 D - 3-phase 15 A
- The main circuit breaker must be rated for the following maximum currents:
  - SC 15 D - 15 A
  - SC 30 D - 15 A
  - SC 60 D - 15 A

Protect the motor by installing the recommended breaker. Failure to do so can result in injury from electrical shock or fire.

Use a power cord and ground wire of over 2 mm<sup>2</sup> (rated at 7 A, 3-phase for SC 15 D) / (rated at 15 A, 3-phase for SC 30 D) / (rated at 15 A, 3-phase for SC 60 D).

When using power cords which are only rated for lower currents, there then exists the risk of excessively heating the wires (risk of starting a fire).

Firmly fit proper round crimp style terminals to electric cord using the appropriate tool and connect to motor terminal. If the connection is loose, it can cause bodily injury or electrical fire.

#### Warning



#### Warning



# Installation

**Table 2: Three-phase connection**

V	Hz	Rated current for mains power circuit breaker - A		
		SC 15 D	SC 30 D	SC 60 D
200	50	1.8	3.1	5.9
200	60	2.2	3,2	6.2
208	60	2.2	3.0	6.2
230	60	2.2	2.9	6.1
380	50	1.1	1.8	3.7
415	50	1.2	1.9	4.0
460	60	1.2	1.7	3.9

---

**Warning**



Be sure to connect the electric cord to the terminals by using cable-gland the 20 mm dia. hole at motor terminal box. If the connection is loose, it can cause bodily injury or electrical fire.

Firmly connected the ground cable of the power cord within the motor terminal box. If this connection is loose, this may then cause injury or electric shock.

You can change to 208-230 V or 380-460 V connection by changing the links. It is wired to 208-230 V connection when delivered to you. If you want to change to 380-460 V connection, remove the electric source terminal M4 nuts and change the links as illustrated in Figure 3.8. Connect the power cord through the cable-gland on the bottom side of terminal box. Connect L1-L2-L3 to U1-V1-W 1 terminals of the motor, respectively.

Activate the emergency stop by the main disconnect switch or breaker.

Protect the motor with a breaker.

Use a power cord and ground wire rated for currents over 10A.

Use round type terminal.

Fit cable-gland.

Connect ground wire to ground terminal.

---

**Warning**



After each modification of power supply cable wiring, a new electrical safety test has to be done according to the national rules.

---

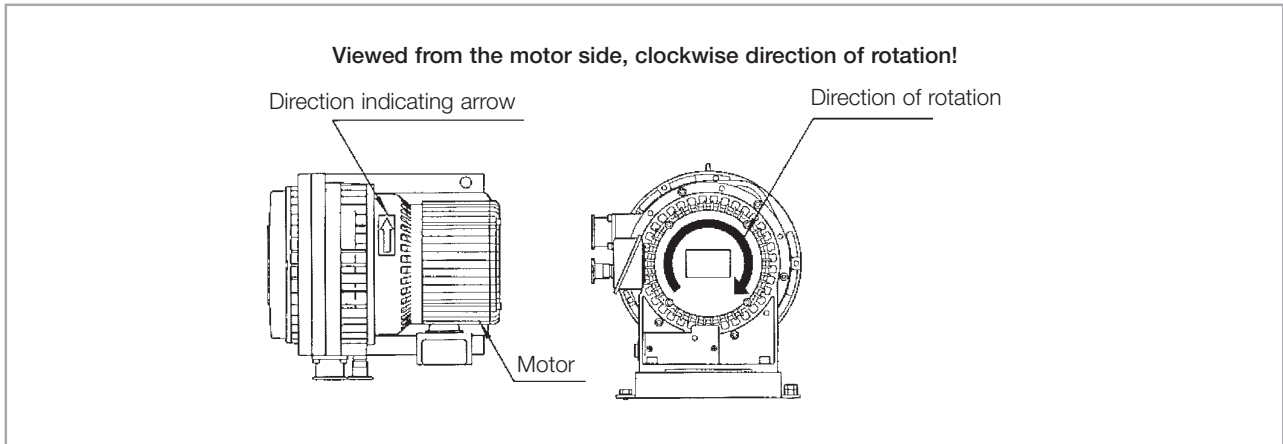

Fig. 3.8 Checking the direction of rotation after having provided the wiring

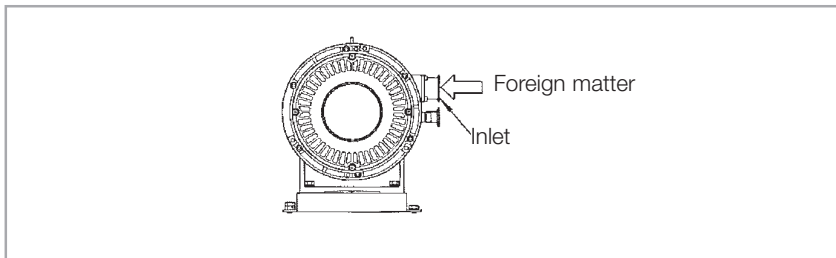

Fig. 3.9 Prevent foreign matter from entering into the pump

Operate the pump with inlet open, and check that air comes out from outlet.

If you plan to switch the pump ON-OFF with remote control, check the pump's rotation direction before connecting it to the vacuum system.

When checking rotation, avoid dropping foreign matter into the inlet.  
Dropping foreign matter into the pump can cause failure.

---

**Caution**

---

If the direction of rotation is wrong, ensure that the incoming power is OFF and then interchange two of the input leads.

# Installation

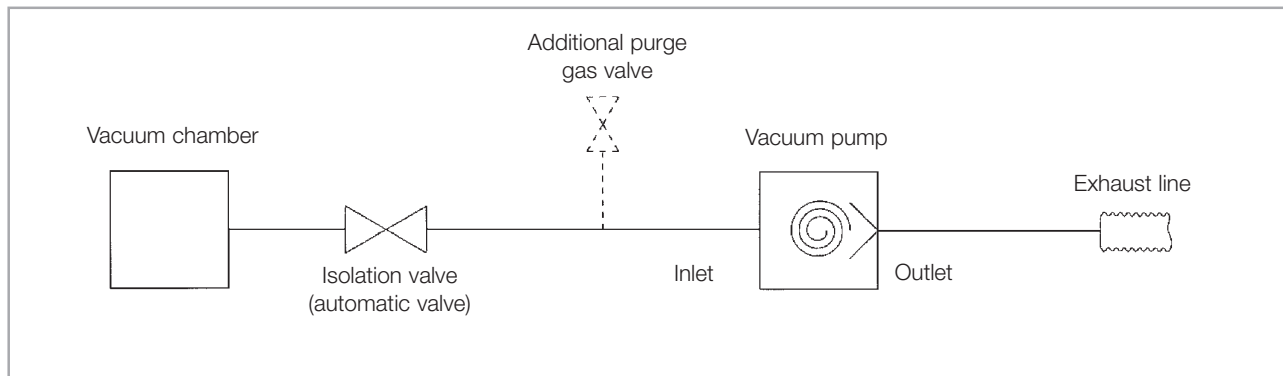

Fig. 3.10 Block diagram of the connection to the vacuum system

## 3.5 Connection to the Vacuum System

- Inlet of the SC 5 D is DN 25 and the exhaust is DN 16.
- Inlet of the SC 15 D is DN 25 and the exhaust is DN 16.
- Inlet of the SC 30 D is DN 40 and the exhaust is DN 25.
- Inlet of the SC 60 D is DN 40 and the exhaust is DN 40.
- Install an isolation valve between the vacuum chamber and the pump's inlet to prevent the drawback of debris from the vacuum pump into the vacuum chamber during start-up or shutdown.
- We recommend the use of an automatic valve as isolation valve which closes during power failure to prevent the drawback of debris from inside the pump into the vacuum chamber.
- Install a purge gas valve between the isolation valve and the pump's inlet. Opening this purge gas valve during operation removes dirt and water vapour from the pump.
- Use the clean connecting tubing between vacuum chamber and vacuum pump. We recommend the use of flexible tubing between the inlet of pump and the vacuum chamber so that the pump's vibration is not transmitted to the vacuum chamber.
- When connecting an exhaust line to the outlet of the vacuum pump, we recommend the following **maximum straight** length:
  - SC 5 D: 30 m DN 16 line
  - SC 15 D: 5 m DN 16 line
  - SC 30 D: 15 m DN 25 line
  - SC 60 D: 40 m DN 40 line
- Make sure that the exhaust line is not clogged during operation.
- Ensure that the pressure at the pump's exhaust is at atmospheric pressure.

## 4 Operation

Do not pump hazardous gases to humans, or explosive, flammable, toxic or corrosive gases or substances which contain chemicals, solvents or powders. Pumping such gases can cause bodily injury from exposure to harmful substances, explosion or fire.

Never put your fingers or foreign matter into ventilation holes of the fan cover, motor set or clearance between cooling fans of stage 1 and stage 2. If done, you can injure your fingers or foreign matter can blow into your eyes.

In order to ensure an adequate air supply, the front side of SCOLLVAC SC 60 D must not be obstructed.

### Warning



### Caution

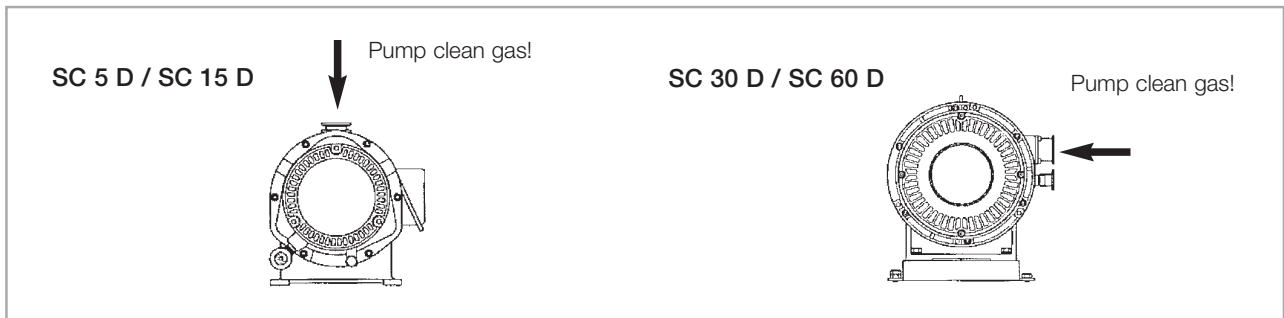

Fig. 4.1 Never pump hazardous gases

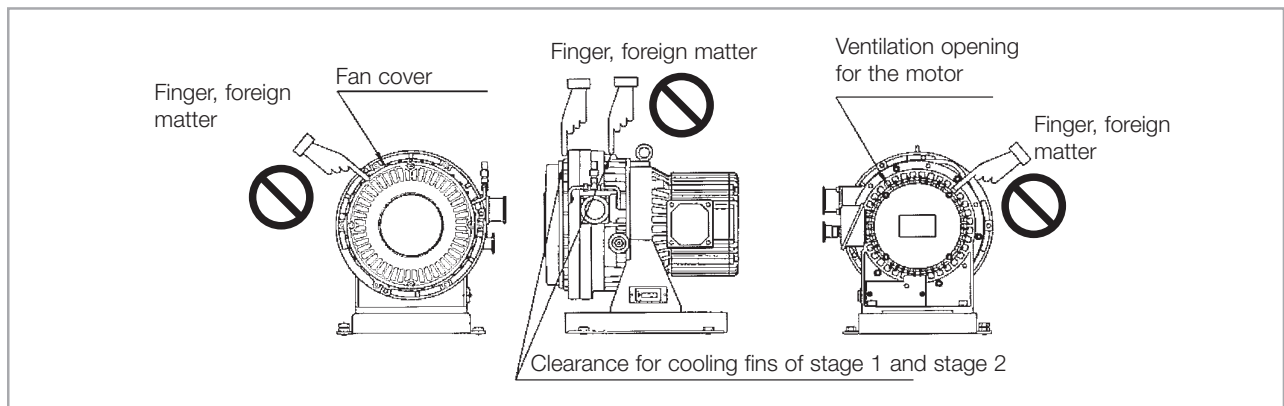

Fig. 4.2 Hazardous points on the pump

# Operation

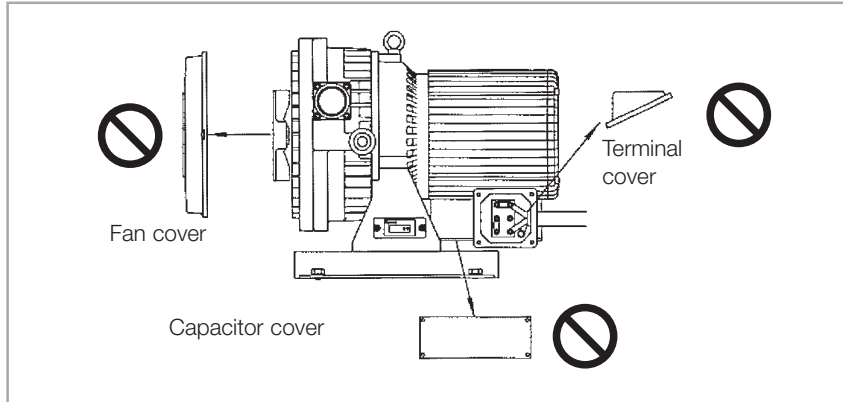

Fig. 4.3 Never alter equipment

---

**Warning**



Never remove or alter safety equipment or covers. Removing or altering this equipment can cause electric shock or bodily injury by rotating objects.

Operate at the pump only **with** the fan cover and the terminal cover in place.

Operate in the single-phase pump only **with** the capacitor cover in place.

#### 4.1 Start-up

---

**Warning**



Remove blank flanges from the inlet and outlet before starting the pump. Operation with blank flanges can cause damage.

If you will be pumping humid air or condensable vapors, open the purge gas valve (refer to Sec. 4.3) before starting the pump as described below.

The pump takes 6-8 hours to reach its ultimate pressure during its initial start-up or after a long idle period.

Close the inlet isolation valve and continue operation for further 6-8 hours. Open the purge gas valve for 3-5 seconds to atmosphere 2-3 times per hour. While the pump was off, moisture may have entered the pump extending the time needed to reach ultimate pressure.

Close the isolation valve between the vacuum pump and vacuum chamber during start-up and shutdown of pump. Otherwise, debris from the pump can be drawn back into the vacuum chamber.

When restarting a pump that is already at operating temperature, open the purge gas valve for 3-5 seconds to atmosphere before restarting the pump. Otherwise, the pump's temperature can become unbalanced causing it to fail.

## Proceed as follows to start the pump:

1. Close the isolation valve to prevent drawback of debris from the vacuum pump into vacuum chamber (open the purge gas valve if one is installed).
2. Switch the vacuum pump ON.
3. Open the isolation valve (close purge gas valve if one is installed) and pump the vacuum chamber.

## 4.2 Pumping

Operating the pump continuously near its ultimate pressure (for example, backing a turbomolecular pump) can cause deposits of foreign matter or moisture in the pump resulting in failure.

Operate the pump with the purge gas valve open (see Sec. 4.3 "Purge Gas Operation"), or close the isolation valve and open the purge gas valve for 3-5 seconds to atmosphere several times once a day to remove foreign matter from inside the pump.

## Operate at specified temperature

When pumping vapour, the inlet gas temperature must be less than 50 °C. When vapour temperature is more than 50 °C, install a chiller or trap in the piping between the vacuum chamber and the pump to reduce the inlet vapour temperature to less than 50 °C. Pumping vapour of over 50 °C can cause failure.

## 4.3 Purge Gas Operation (pumping of vapours)

When pumping vapour, open the purge gas port of the SCROLLVAC. If you pump vapour with the purge gas valve port closed, condensed moisture remains in the pump, resulting in failure.

Use care to avoid damaging the purge gas valve port (especially the silencer).

When the purge gas valve is open, noise level increases and ultimate pressure deteriorates slightly.

---

### Caution

---

## Purpose of the Purge Gas

The moisture volume drawn into pump varies depending on the temperature and pressure in the vacuum chamber. Pumping humid gas can result in moisture condensing in the pump. This remaining moisture can cause a deterioration of the ultimate pressure or pump failure. When the vacuum chamber contains gas with humidity of over 60 % RH, the pump must be operated with the purge gas valve open. Operating the pump with the purge gas valve open removes the moisture which allows the pump to reach its ultimate pressure.

# Operation

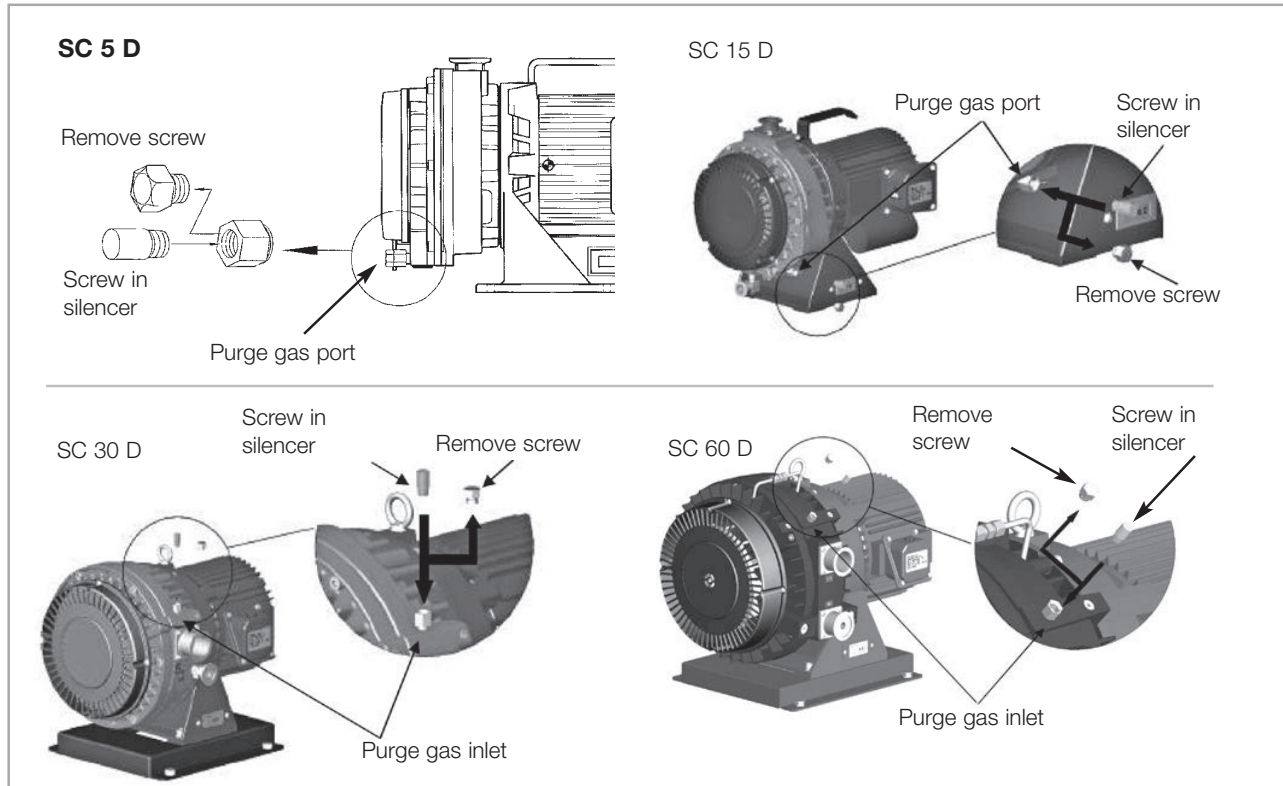

Fig. 4.4 Setting up the pump for purge gas operation

## Warning



### Never change the purge gas conditions during operation (ON/OFF)

Open or close the purge gas valve port only after shutting down the pump. Opening or closing the purge gas valve during operation can cause the pump to fail and cause bodily injury.

To open the purge gas supply, shutdown the pump, remove the plug from the purge gas port and screw the silencer into the purge gas port. (Fig. 4.4).

To close the purge gas valve, shutdown the pump. Remove the silencer from the purge gas valve port and replace it with the plug. Lightly tighten the plug with a wrench.

When supplying nitrogen gas or dry air to the purge gas valve port, set the pressure equivalent to atmospheric pressure while keeping the flow below:

- $9 \text{ l} \cdot \text{min}^{-1}$  for the SC 5 D or
- $10 \text{ l} \cdot \text{min}^{-1}$  for the SC 15 D, SC 30 D and SC 60 D.

## Caution

Exceeding a purge gas flow of 9 or 10 l/min cause pump failure.



## 4.4 Shutdown

After vapour has been pumped, continue to operate the pump with the purge gas valve open for over one hour. If you close the purge gas valve port or stop the pump soon after vapour has been pumped, condensed moisture remains in the pump, resulting in failure.

- To prevent the drawback of debris from the vacuum pump into vacuum chamber during shutdown, close the isolation valve (open the purge gas valve if one is installed).
- Switch the vacuum pump off.

When the pump stops, atmospheric air is drawn back from the purge gas valve port to the inside of pump, and pressure inside pump rises to about atmospheric pressure. To maintain vacuum in the vacuum chamber and prevent the drawback of debris from vacuum pump into vacuum chamber, close the isolation valve to the vacuum chamber before shutting off the pump.

---

### Warning



# Maintenance

## 5 Maintenance

---

### Caution

Neglecting maintenance and inspection can cause poor performance and pump failure.

To remove debris accumulated in the vacuum pump, operate the pump several times for 3-5 seconds (once a day) with its inlet open to atmospheric air (or open the purge gas valve if one is installed).

---

### Warning



Allow the pump to cool down before doing maintenance. Performing maintenance immediately after shutdown can cause bodily injury such as burns.

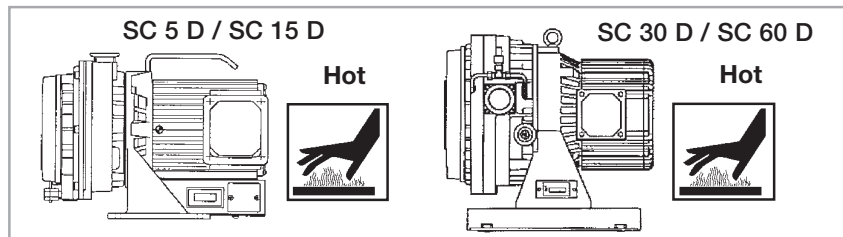

Fig. 5.1

---

### Warning



#### Be careful of automatic restart

The thermal protection on the single-phase motor automatically resets. This motor restarts without warning after the protector trips back. Be sure to switch off the electric power before maintenance or inspection.

---

### Warning



#### Switch off electric source

Be sure to switch off the electrical power before maintenance or inspection. Failure to do so can cause bodily injury from electric shock or rotating objects.

---

### Caution

More frequent maintenance is required if the ambient temperature is too high. The maintenance interval is based on 5 - 40 °C ambient temperature and 25 °C average yearly temperature.

Shorten the maintenance interval if the ambient temperature is higher. Otherwise, the pump may fail prematurely.

The maintenance schedule assumes that the pump is exposed to clean gas only.

You must shorten the maintenance interval when pumping vapour since vapour temperature, disposal volume, disposal frequency and substances in the vapour influence the pump's operation.

---

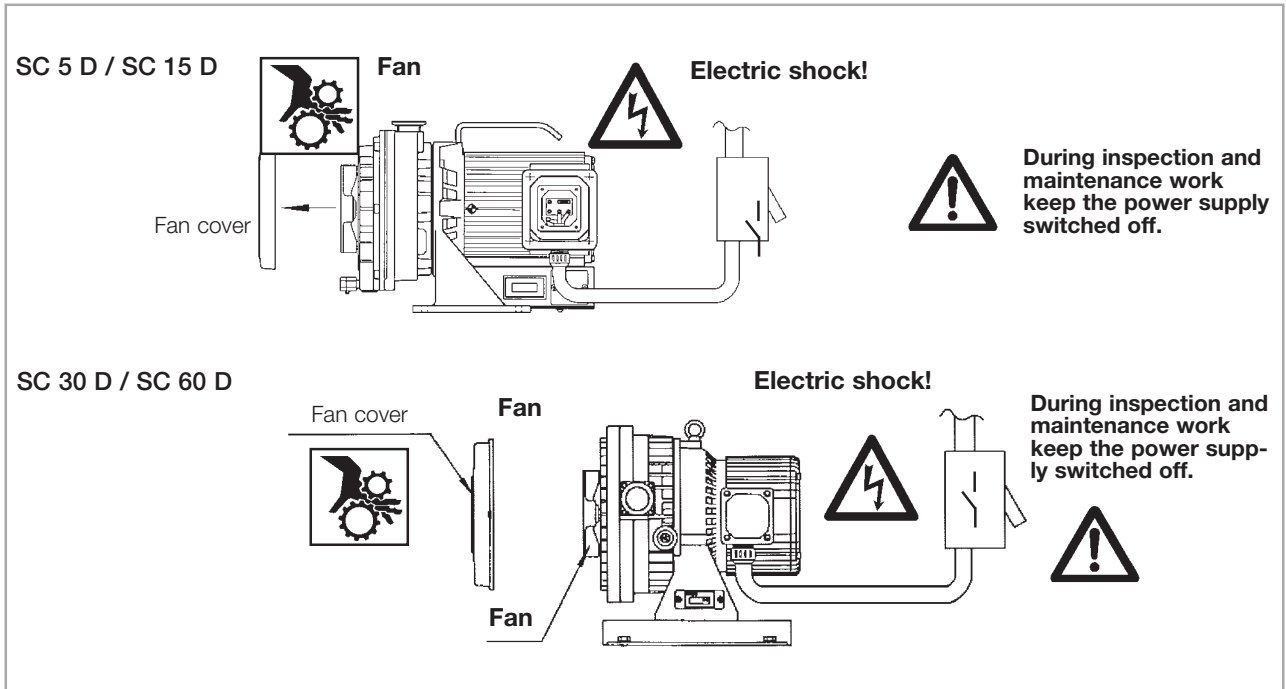

Fig. 5.2

# Maintenance

## 5.1 Table - Maintenance

When the maintenance interval has been reached, contact Oerlikon Leybold Vacuum to arrange the required maintenance. Never disassemble, reassemble or alter the pump yourself. We are not responsible for any accidents caused by disassembly, assembly or alteration which was done by the user or non-specialist.

Where to inspect	Maintenance interval			Remarks
	Yearly or every 8,000 hours	Every two years or every 16,000 hours	After having pumped vapours 400x	
Ball bearing	grease / ▲	○	▲	
Tip seal	*	○	▲	
Seal	*	○	▲	
O-ring	*	○	▲	
Exhaust valve	*	○	▲	
Purge	*	○	▲	
Pin crank	▲	▲	▲	
Stopper	▲	▲	▲	
Vacuum pump itself	inside cleaning / ▲	inside cleaning / ▲	inside cleaning / ▲	

\* Small maintenance kit

○ Large maintenance kit

▲ Replace in case of malfunction

Note 1: Exclusively use the specified DIS grease.

Note 2 : The maintenance interval is the time interval or running hours whichever is reached first.

## 5.2 Oerlikon Leybold Vacuum Service

Whenever you send us equipment, indicate whether the equipment is contaminated or is free of substances which could pose a health hazard. If it is contaminated, specify exactly which substances are involved. You must use the form we have prepared for this purpose.

A copy of the form has been reproduced at the end of these Operating Instructions: "Declaration of Contamination for Compressors, Vacuum Pumps and Components". Another suitable form is available from [www.oerlikon.com](http://www.oerlikon.com) Æ Oerlikon Leybold Vacuum Systems Æ Documentation Æ Download Documents.

Attach the form to the equipment or enclose it with the equipment.

This statement detailing the type of contamination is required to satisfy legal requirements and for the protection of our employees.

We must return to the sender any equipment which is not accompanied by a contamination statement.

The pump must be packed in such a way, that it will not be damaged during shipping and so that any contaminants are not released from the package.

## 5.3 Waste Disposal

The pump may be contaminated by the process or by environmental influences. In this case it must be decontaminated in accordance with the relevant regulations. We offer this service at fixed prices. Further details are available upon request.

Contaminated parts can be detrimental to health and environment. Before beginning to work, find out whether any parts are contaminated. Adhere to the relevant regulations and take the necessary precautions when handling contaminated parts.

Separate clean components according to their materials, and dispose of accordingly.

If you send equipment to Oerlikon Leybold Vacuum mind the regulations given in Section 5.2. "Oerlikon Leybold Vacuum Service".

### Contamination

### Form

---

#### Warning



### Contamination

---

#### Warning



# Troubleshooting

## 6 Troubleshooting

If the pump malfunctions, please refer to the following chart for help in solving the problems. If you cannot solve the problem, please contact Oerlikon Leybold Vacuum.

<b>Fault</b>	<b>Possible cause</b>	<b>Remedy</b>
Pump does not rotate.	Breaker malfunction.	Inspect and repair.
	Wiring becomes loose or cut.	Repair or replace.
	Voltage drops.	Check length and size of cable.
	Motor malfunctions.	Inspect and repair.
	Pump malfunctions.	Inspect and repair.
	SC 5 D only Switch is turned OFF.	Turn switch ON.
	SC 5 D only ON-OFF switch is damaged.	Replace.
Ultimate pressure is insufficient.	Thermal protector trips.	Inspect connection Inspect connection. Inspect voltage. Inspect and repair.
	Air leaks for pumping.	Check tightness of piping.
	Moisture or solvent has condensed in pump.	Open inlet to atmosphere and operate for a few minutes and then operate for about 24 hours with the inlet closed. Install a trap or a filter to prevent water and solvent from entering the pump.
	O-ring is damaged.	Replace.
Abnormal sound, vibration.	Purge gas valve port is clogged.	Clean silencer. - Replace
	Connections loose.	Tighten connections.
	The pump is not level.	Level the pump.
	Foreign matter enters inside of Pump.	Inspect and clean.
	Failure of exhaust valve.	Inspect and replace.
	Failure of motor.	Inspect and replace.
Failure of pump.	Inspect and change resp. replace.	

## 7 Spare Parts

		<b>SCROLLVAC</b>			
		<b>SC 5 D</b>	<b>SC 15 D</b>	<b>SC 30 D</b>	<b>SC 60 D</b>
Maintenance kits					
Small maintenance kit (after 8,000 h)	Minor Kit	P/N EK 870000496	P/N EK 870000497	P/N EK 870000498	P/N EK 870000519
Large maintenance kit (after 16,000 h)	Major Kit	P/N EK 870000499	P/N EK 870000500	P/N EK 870000501	P/N EK 870000520
Toolkit		P/N EK 870000502	P/N EK 870000503	P/N EK 870000503	P/N EK 870000521
Scroll profiled seal (Tip Seal)		P/N E 870000510	P/N E 870000511	P/N E 870000512	P/N E 870000522
Shaft installation kit (Pin Crank Kit)		P/N EK 870000507	P/N EK 870000508	P/N EK 870000509	P/N EK 870000523
Eccentric shaft		P/N EK 870000504	P/N EK 870000505	P/N EK 870000506	P/N EK 870000534
Airflush inlet filter		P/N EK 870000515	P/N EK 870000515	P/N EK 870000515	P/N EK 870000515
Lubricant		P/N EK 870000524	P/N EK 870000524	P/N EK 870000524	P/N EK 870000524



## EG- Konformitätserklärung

Hiermit erklären wir, die Oerlikon Leybold Vakuum GmbH, dass die nachfolgend bezeichneten Produkte in der von uns in Verkehr gebrachten Ausführung den einschlägigen EG-Richtlinien entsprechen.

Bei einer nicht mit uns abgestimmten Änderung eines Produktes verliert diese Erklärung ihre Gültigkeit.

Die Einhaltung der EMV -Richtlinien setzt einen EMV -angepassten Einbau der Komponenten in der Anlage oder Maschine voraus.

**Bezeichnung der Produkte:** Scroll-Vakuumpumpen

<b>Typen:</b>	SC 5 D	<b>Kat.-Nrn.</b>	133 000, 133 100
	SC 15 D		133 001, 133 003, 133 101
	SC 30 D		133 002, 133 004, 133 102
	SC 60 D		133 008

### Die Produkte entsprechen folgenden Richtlinien:

- EG-Maschinenrichtlinie (98/37/EG)
- EG-Niederspannungsrichtlinie (2006/95/EG)
- EG-Richtlinie Elektromagnetische Verträglichkeit, (2004/108/EG)

### Angewandte harmonisierte Normen:

- EN 1012 -2, 1996, Sicherheitsanforderungen an Kompressoren und Vakuumpumpen, Teil 2: Vakuumpumpen
- EN 60204 - 1, 2006, Sicherheit von Maschinen - Elektrische Ausrüstung von Maschinen, Teil 1: Allgemeine Anforderungen
- EN 60034 - 1, 2004 Drehende elektrische Maschinen, Teil 1: Bemessungen und Betriebsverhalten





## EC Declaration of Conformity

We, Oerlikon Leybold Vacuum GmbH, hereby declare that the products specified and listed below which we have placed on the market, comply with the applicable EC Council Directives.

This declaration becomes invalid if modifications are made to the product without agreement of Oerlikon Leybold Vacuum GmbH.

Compliance with the EMC Directives requires that the components are installed within a system or machine in a manner adapted to EMC requirements.

**Designation of the products:** Scroll type vacuum pump SCROLLVAC

<b>Model:</b>	SC 5 D	<b>Part-No.:</b>	133 000, 133 100
	SC 15 D		133 001, 133 003, 133 101
	SC 30 D		133 002, 133 004, 133 102
	SC 60 D		133 008

**The product complies to the following European Council Directives:**

- EC-Machinery Directive (98/37/EC)
- EC-Directive related to electrical equipment designed for use within certain voltage limits (2006/95/EC)
- EC-Directive relating to electromagnetic compatibility, (2004/108/EC)

**Related, harmonized standards:**

- EN 1012-2, 1996 Safety requirements for compressors and vacuum pumps – Part 2: Vacuum pumps
- EN 60034-1, 2004 Rotating electrical machines – Part 1: Rating and performance
- EN 60204-1, 2006 Safety of machinery - Electrical equipment of machines – Part 1: General requirements

Cologne

Cologne

---

Dr. Ulrich Jung  
Head of Research & Development  
Vice President

---

Head of Quality Management

# Declaration of Contamination of Compressors, Vacuum Pumps and Components

The repair and / or servicing of compressors, vacuum pumps and components will be carried out only if a correctly completed declaration has been submitted. **Non-completion will result in delay.** The manufacturer can refuse to accept any equipment without a declaration.

**A separate declaration has to be completed for each single component.**

This declaration may be completed and signed only by authorised and qualified staff.

Customer/Dep./Institute: _____	<b>Reason for return</b> <input checked="" type="checkbox"/> applicable please mark
_____	<input type="checkbox"/> <b>Repair</b> <input type="checkbox"/> chargeable <input type="checkbox"/> warranty
Address _____	<input type="checkbox"/> <b>Exchange</b> <input type="checkbox"/> chargeable <input type="checkbox"/> warranty
_____	<input type="checkbox"/> exchange already arranged / received
Person to contact: _____	<b>Return only:</b> <input type="checkbox"/> rent <input type="checkbox"/> loan <input type="checkbox"/> for credit
Phone: _____ Fax: _____	<b>Calibration:</b> <input type="checkbox"/> DKD <input type="checkbox"/> Factory calibration
End user: _____	<input type="checkbox"/> Quality test certificate DIN 55350-18-4.2.1

<b>A. Description of the Oerlikon Leybold Vacuum product</b>	Failure description: _____
Material description: _____	_____
Catalog number: _____	Additional parts: _____
Serial number: _____	Application Tool: _____
Type of oil (Forevacuum pumps): _____	Application Process: _____

<b>B. Condition of the equipment</b>						
	No <sup>1)</sup>	Yes	No	<b>Contamination:</b>	No <sup>1)</sup>	Yes
1. Has the equipment been used <sup>1)</sup>	<input type="checkbox"/>	<input type="checkbox"/>	<input checked="" type="checkbox"/>	toxic	<input type="checkbox"/>	<input type="checkbox"/>
2. Drained (Product/service fluid)	<input type="checkbox"/>	<input type="checkbox"/>	<input type="checkbox"/>	corrosive	<input type="checkbox"/>	<input type="checkbox"/>
3. All openings sealed airtight	<input type="checkbox"/>	<input type="checkbox"/>	<input type="checkbox"/>	flammable	<input type="checkbox"/>	<input type="checkbox"/>
4. Purged	<input type="checkbox"/>	<input type="checkbox"/>	<input type="checkbox"/>	explosive <sup>2)</sup>	<input type="checkbox"/>	<input type="checkbox"/>
If yes which cleaning agent: _____				radioactive <sup>2)</sup>	<input type="checkbox"/>	<input type="checkbox"/>
and which method of cleaning: _____				microbiological <sup>2)</sup>	<input type="checkbox"/>	<input type="checkbox"/>
<sup>1)</sup> if answered with "No" go to <b>D.</b>				other harmful substances	<input type="checkbox"/>	<input type="checkbox"/>

<b>C. Description of processed substances (Please fill in absolutely)</b>	
1. What substances have come into contact with the equipment: Trade name and / or chemical term of service fluids and substances processed, properties of the substances; According to safety data sheet (e.g. toxic, inflammable, corrosive, radioactive)	
Tradename: _____	Chemical name: _____
a) _____	_____
b) _____	_____
c) _____	_____
d) _____	_____
2. Are these substances harmful?	No <input type="checkbox"/> Yes <input type="checkbox"/>
3. Dangerous decomposition products when heated?	No <input type="checkbox"/> Yes <input type="checkbox"/>
If yes, which? _____	_____

**<sup>2)</sup> Components contaminated by microbiological, explosive or radioactive products/substances will not be accepted without written evidence of decontamination.**

<b>D. Legally binding declaration</b>	
I / we hereby declare that the information supplied on this form is accurate and sufficient to judge any contamination level.	
Name of authorised person (block letters): _____	_____
Date _____	
Signatur of authorised person _____	firm stamp