

TRANSLATION OF THE ORIGINAL OPERATING INSTRUCTIONS

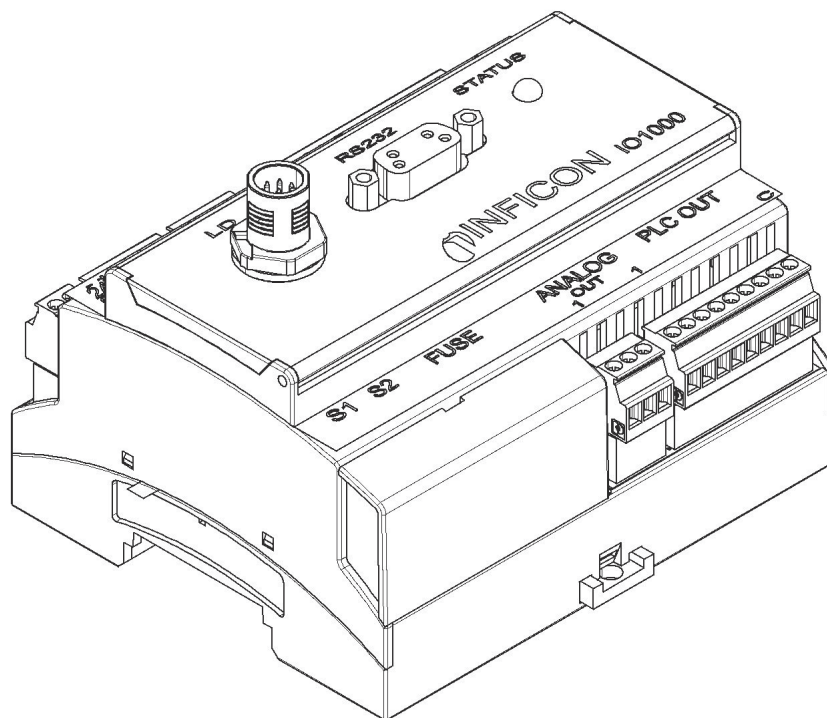

IO1000

I/O module

Catalog no. 560-310
from software version I/O module 1.11
Document no. jiqc10en1-c (1408)

Chemtech Scientific provides access to this content as a courtesy.
We do not own the content contained in this document.
All rights and credit go directly to its rightful owners.
www.chemtechsci.com
Call us at: 484-424-9415



This document applies to the software version stated on the cover page. Documents for other software versions are available from our sales department.

Reprint, translation and duplication need to be approved in writing by INFICON GmbH.

Content

1	About this manual	4
1.1	Target groups	4
1.2	Other applicable documents	4
1.3	Presentation of information	4
1.3.1	Warnings	4
1.3.2	Text markings	5
2	Safety	6
2.1	Intended use	6
2.2	Owner requirements	6
2.3	Operator requirements	6
3	Shipment, transport, storage	7
4	Description	8
4.1	Construction of the I/O module	8
4.2	Function	14
4.3	Technical data	14
4.3.1	Mechanical data	14
4.3.2	Electrical data	14
4.3.3	Ambient conditions	14
5	Installation and removal	15
5.1	Mount I/O module on DIN-TS35 top hat rail	15
5.1.1	Establish connections	15
5.2	Remove the I/O module from the DIN-TS35 top hat rail	16
6	Disposal	17

1 About this manual

1.1 Target groups

This installation manual is intended for the owner and for technically qualified personnel with experience in leak detection technology and integration of leak detection devices in leak detection systems. In addition, the installation and use of the unit require knowledge of electronic interfaces.

1.2 Other applicable documents

- Operating instructions of the connected leak detector
- Interface protocols LDS3000, document no. jira54
- Interface protocols HLD6000, document no. kira43

1.3 Presentation of information

1.3.1 Warnings



1.3.2 Text markings

Marking	Meaning
✓	Requirement for execution of an action
x	Tool or aid for an action
▶	Instruction
1, 2, 3, ...	Several instructions in a fixed order
⇒	Result of an action

2 Safety

2.1 Intended use

The I/O module is a device interface between a leak detector and an external controller.

- ▶ Install, operate and service the unit only in compliance with these instructions.
- ▶ Comply with the limits of application (see [chapter 4.3, page 14](#)).

2.2 Owner requirements

Safety conscious operation

- ▶ Operate and install the unit only if it is in perfect working order and as intended, in a safety-conscious manner and fully aware of dangers, in compliance with these instructions.
- ▶ Fulfill and ensure compliance with the following regulations:
 - Intended use
 - Generally applicable safety and accident prevention regulations
 - International, national and local standards and guidelines
 - Additional provisions and regulations that are specific to the unit
- ▶ Use only original parts or parts approved by the manufacturer.
- ▶ Keep this manual available at the operating site.

Personnel qualifications

- ▶ All work must be performed only by technical specialists who have been trained on the unit.
- ▶ Allow personnel in training to work with the unit only under the supervision of technical specialists.
- ▶ Make sure that the authorized personnel have read and understood these instructions and all other applicable documents (see [chapter 1.2, page 4](#)), especially the information on safety, maintenance and repairs, before starting work.
- ▶ Define responsibilities, authorizations and supervision of personnel.

2.3 Operator requirements

- ▶ Read, observe and follow the information in these instructions and the working instructions created by the owner, especially the safety instructions and warnings.
- ▶ Perform all work based on the complete instructions.

3 Shipment, transport, storage

Scope of delivery

Article	Quantity
I/O module	1
Operating instructions	1

- ▶ Please check the scope of delivery of the product for completeness after receipt.

Transport

NOTICE

Damage due to unsuitable packaging material

Transport in unsuitable packaging material can damage the unit.

- ▶ Transport the unit only in the original packaging material.
- ▶ Keep original packaging material.

Storage

- ▶ Always store the unit in compliance with the technical data, see [chapter 4.3, page 14](#).

4 Description

4.1 Construction of the I/O module

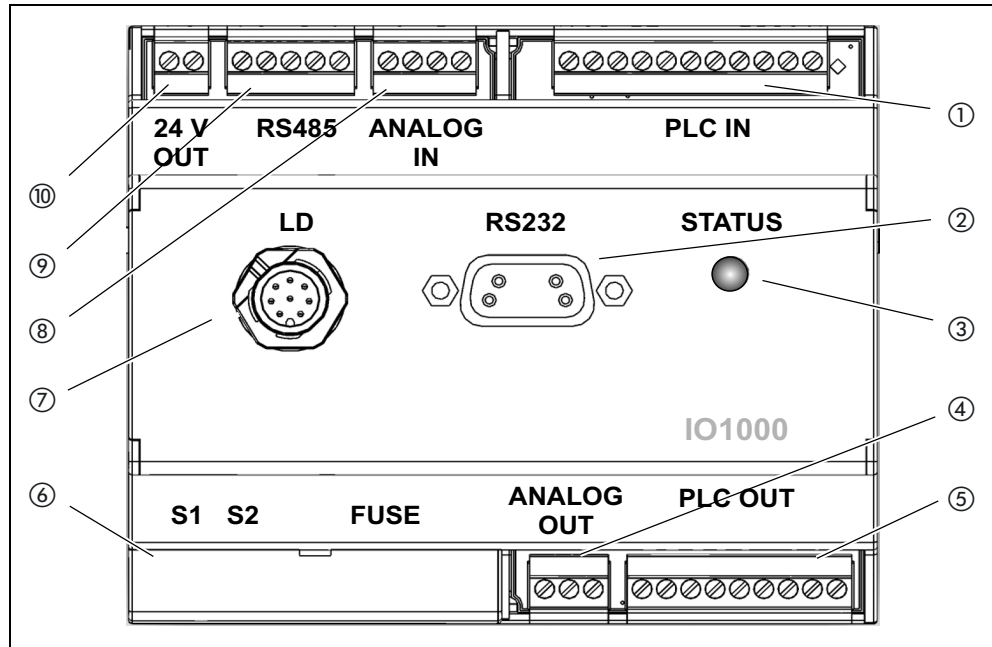

Fig. 1 Front view

- | | |
|------------------------------|-----------------------------------|
| ① PLC IN, digital inputs | ⑥ DIP switch cover and fuse |
| ② RS232 | ⑦ LD, connection of leak detector |
| ③ Status LED | ⑧ ANALOG IN, analog inputs |
| ④ ANALOG OUT, analog outputs | ⑨ RS485 |
| ⑤ PLC OUT, digital outputs | ⑩ 24 V OUT, 24 volt output |

PLC IN ①

Digital inputs

Galvanic isolation (max. 60 V DC, 25 V VAC against GND)

Max. permissible input voltage: $U = 35 \text{ V}$

Active signal: $U = 13 \dots 35 \text{ V}$ (typically 24 V), $I = \text{approx. } 7 \text{ mA}$

Inactive signal: $U < 7 \text{ V}$ (typically 0 V), $I = 0 \text{ mA}$

Pin assignment: The input pins PLC-IN 1 to PLC-IN 10 can be configured freely, see the following example.

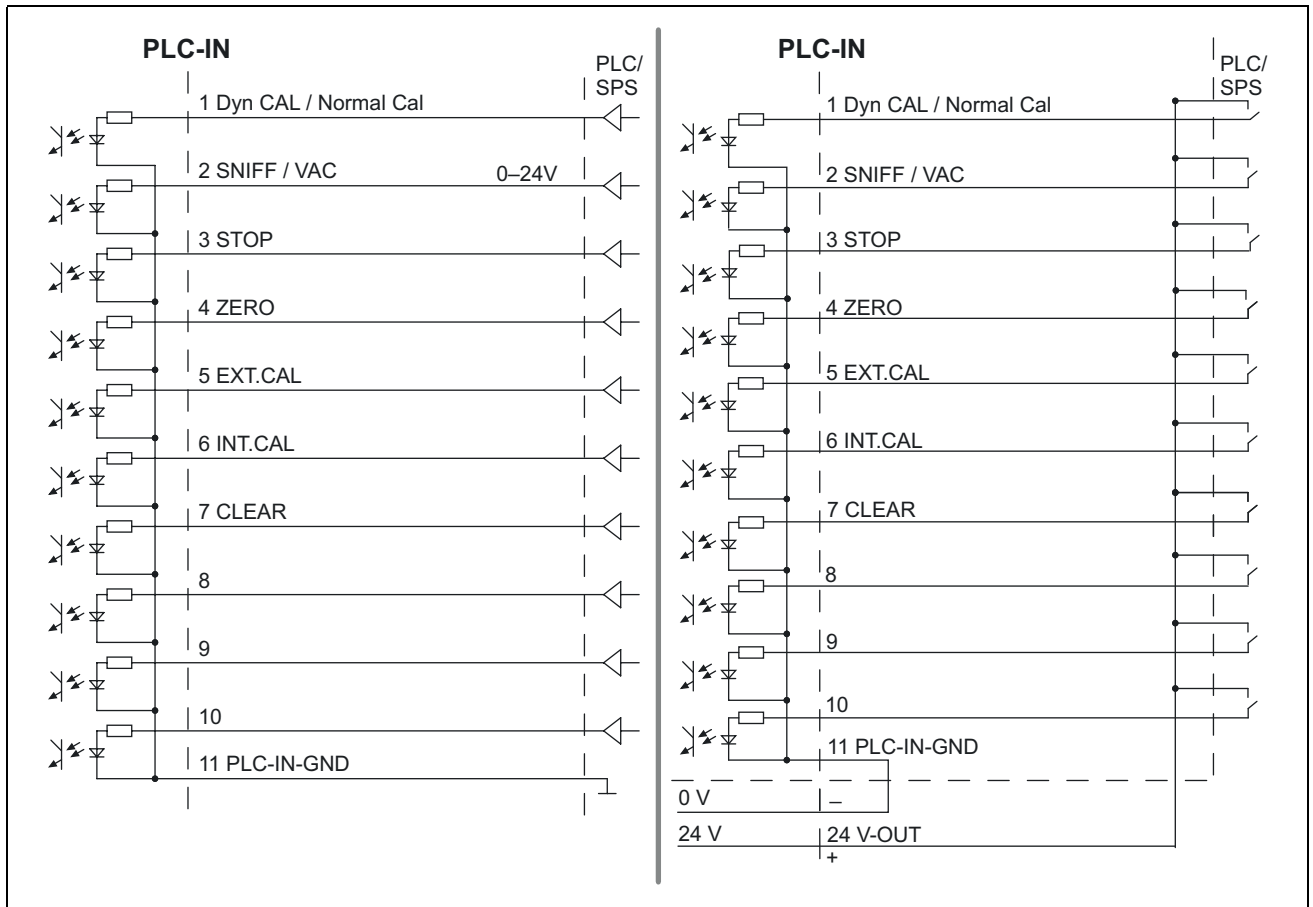

Fig. 2 Sample wiring, digital inputs with PLC. Left: Driver outputs. Right: Potential-free contacts

PLC OUT ⑤

Digital outputs

Galvanic isolation (max. 60 V DC, 25 V VAC against GND)

Max. permissible load per output: $U = 30 \text{ V}$, $I = 0.75 \text{ A}$

Fuses for digital outputs 1 ... 4 and 5 ... 8: $2 \times 0.75 \text{ A}$

Pin assignment: The output pins PLC_OUT_1 to PLC_OUT_8 can be configured freely, see the following example.

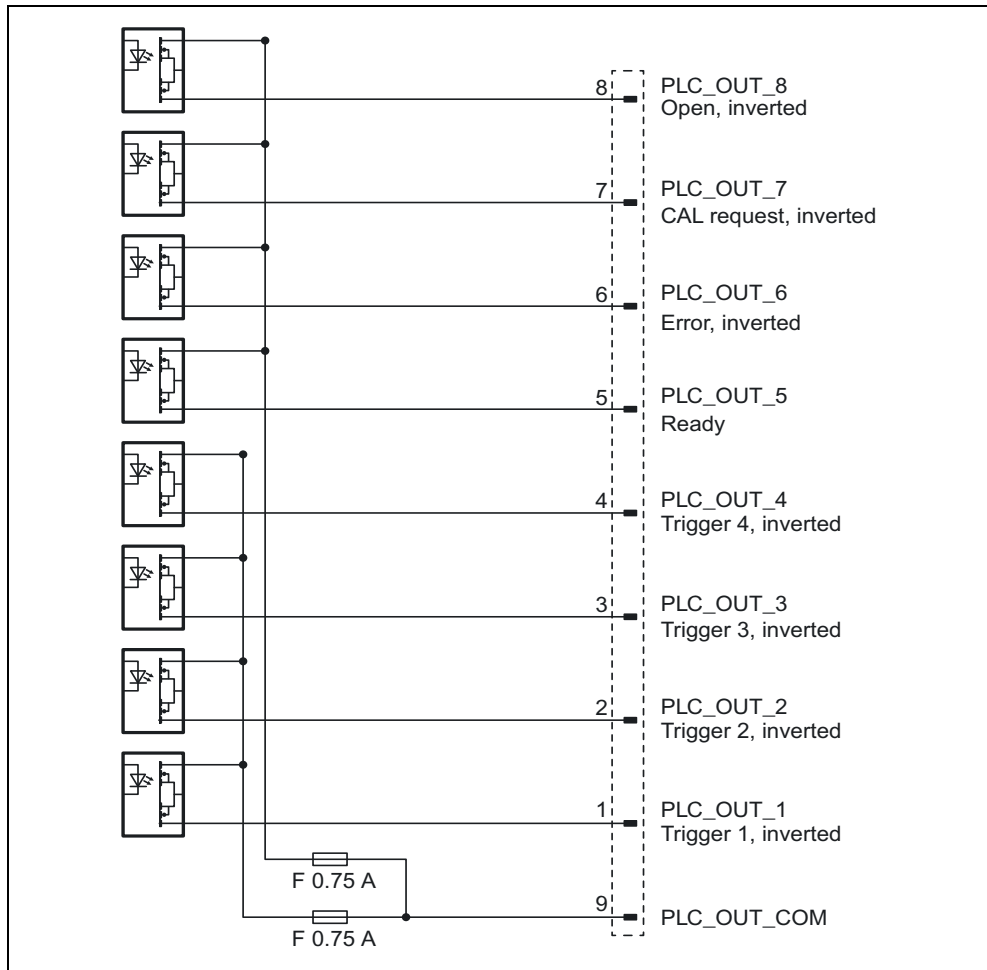

Fig. 3 Sample wiring, digital outputs

ANALOG IN ⑧

Analog input (input voltage range 0 V to 10.8 V)

Pin assignment:

1	24V supply (output)
2	GND to 24V supply
3	Analog input (0 V to 10.8 V)
4	GND to analog input

ANALOG OUT ④

Analog outputs (e.g. for logging leakage rate and backing pressure)

Galvanic isolation (max. 60 V DC, 25 V VAC against GND)

Voltage range	0 ... 10 V
Precision	±15 mV offset, additional ±1% from measurement (current output voltage) as linearity error (at 25 °C)
Resolution	typ. 2.5 mV
Load	> 10 kΩ

Pin assignment:

1	Analog output 1: ANALOG-OUT 1
2	Analog output 2: ANALOG-OUT 2
3	GND to analog output

The output pins can be freely configured.

RS232 ②

Connection for RS-232

Galvanic isolation (max. 60 V DC, 25 V VAC against GND)

Pin assignment:

Pin	Name
2	TxD
3	RxD
5	GND

A normal RS-232 cable must be used for the connection (1:1 connection, RxD and TxD not crossed, no zero-modem cable).

► Deactivate RS-232 hardware handshake in RS-232 control program.

If the hardware handshake cannot be deactivated, the RS-232 can be used as follows:

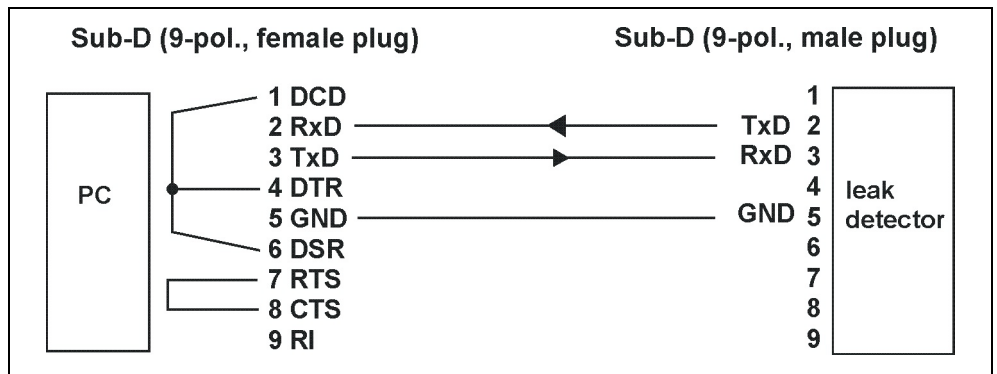

Fig. 4 Connection with RS-232 cable (in case hardware handshake cannot be deactivated)

RS485 ⑨

Connection for RS-485

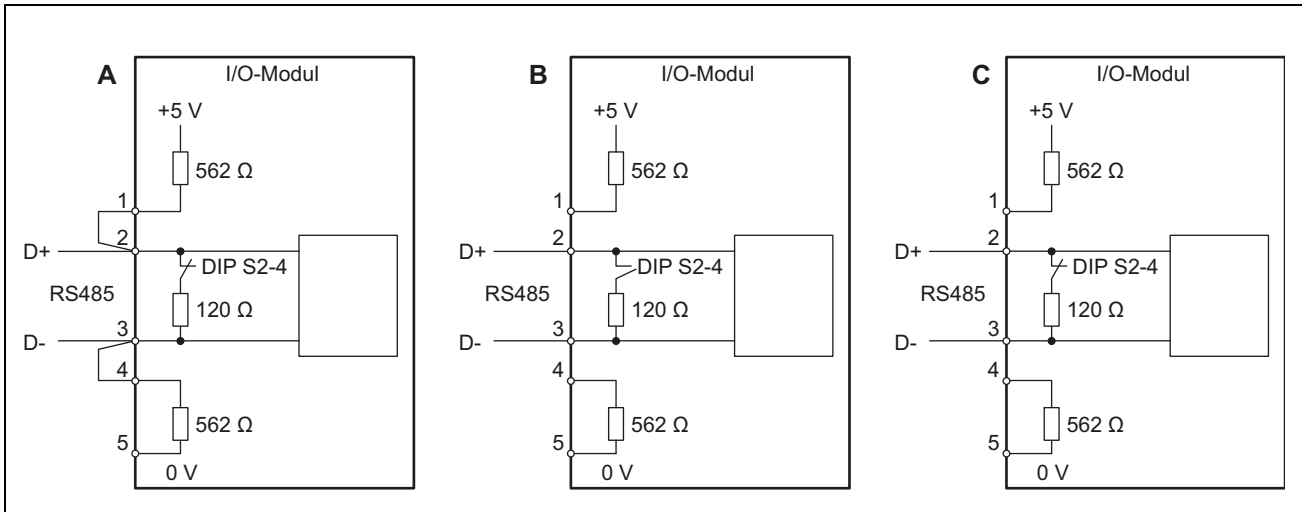

Fig. 5 RS-485 bus terminator

- A: Active bus terminator
- B: Without bus terminator
- C: Passive bus terminator

Galvanic isolation (max. 60 V DC, 25 V VAC against GND)

Pin assignment:

Pin	Name
1	Connect pull-up resistor (562 Ω against +5 V) with D+ if necessary
2	D+
3	D-
4	Connect pull-down (562 Ω against GND) with D- if necessary
5	COM

The bus terminator integrated in the I/O module (120 Ω) between D+ and D- can be disabled via DIP switches S2-4. The BUS address is 1. BUS operation with more than two subscribers is not possible.

STATUS-LED ③

Color	Status	Meaning
Red	illuminates	Unit not functional or defective
Red	flashes	Not ready for operation, communication to leak detector is not available
Cyan	illuminates	Ready for operation; communication to leak detector available
Green	Flashes quickly	Boot loader active, ready for software update
Green	Flashes slowly	Data reception on RS232
Yellow	Flashes slowly	Data reception on RS485
–	off	No operating voltage

FUSE and DIP switch S1, S2 ⑥

Fuses for digital outputs and DIP switches (under the cover)

Fuses for digital outputs 1 ... 4 and 5 ... 8:

2 x 0.75 A (Schurter: 7010.9800.xx)

DIP switch S1	LDS3000	HLD6000	Contact			
			4	3	2	1
Factory setting (default value of the interface protocol by the leak detector or control unit)	•	•	0	0	0	0
ASCII protocol	•	•	0	0	1	0
LD protocol	•	•	0	0	1	1
Binary protocol	•		0	1	0	1
LDS1000 protocol	•		0	1	1	0
Normal protocol		•	0	0	0	1
Simple protocol		•	0	1	0	0

1 = ON, 0 = OFF

DIP switch S2	Contact			
	4	3	2	1
Activate boot mode for software update	X	+	0	0
Disable bus terminator 120 Ω for RS-485	1	X	0	0

1 = ON, 0 = OFF, + = switching from OFF to ON during operation,
X = random

Connection LD ⑦

Connection for the data cable to the leak detector

24V OUT ⑩

24V output

Pin assignment:

Pin	Name
+	+24 V
-	GND

The I/O module is supplied with voltage by the leak detector and requires no separate power supply. The 24V output is not used for voltage supply to the I/O module.

The 24V output of the I/O module can be used as an active signal for the PLC inputs and outputs.

4.2 Function

The I/O module is a device interface between the leak detector and an external controller. The I/O module is equipped with

- one RS-232 connection
- one RS-485 connection
- one analog input
- ten digital inputs
- two analog outputs
- eight digital outputs

The actual function is determined by the software of the connected leak detector.

4.3 Technical data

4.3.1 Mechanical data

Dimensions (W x H x D)	107.6 mm x 89.7 mm x 76.6 mm
Weight	300 g

4.3.2 Electrical data

Supply voltage	24 V DC
----------------	---------

4.3.3 Ambient conditions

Permissible ambient temperature (during operation)	10 °C ... 45 °C
Permissible storage temperature	-20 °C ... 60 °C
Max. relative humidity up to 31 °C	80%
Max. relative humidity from 31 °C to 40 °C	decreasing linearly from 80% to 50%
Max. relative humidity above 40 °C	50%
Protection class	IP 20
Pollution degree	II
Max. altitude above sea level	2000 m

5 Installation and removal

5.1 Mount I/O module on DIN-TS35 top hat rail

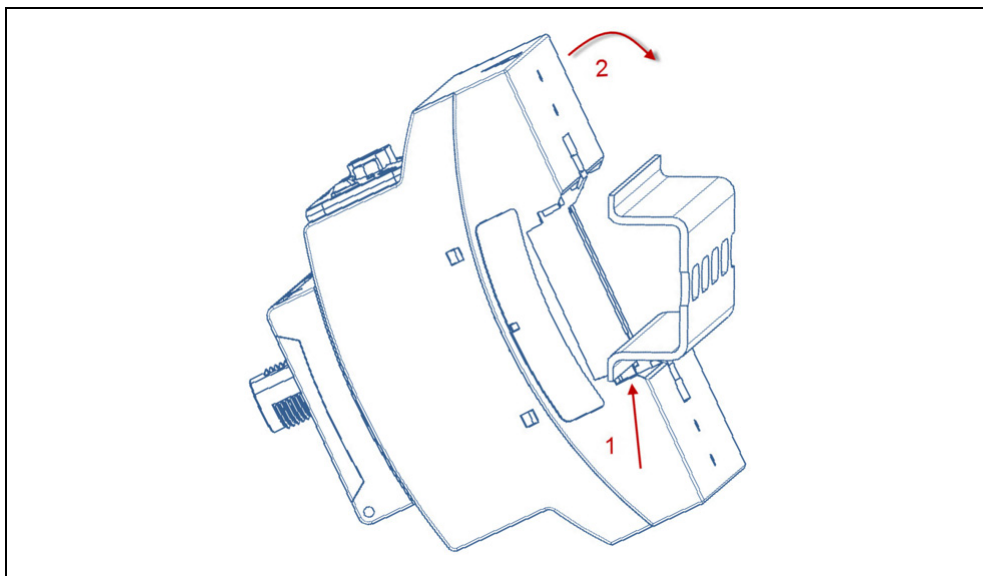

Fig. 6 Mounting of I/O module

- 1 Hook unit on top hat rail at bottom.
- 2 Press unit onto top hat rail at top.

5.1.1 Establish connections

Connecting I/O module with leak detector

The I/O module communicates via data cable with the leak detector and is supplied with voltage by the data cable.

- 1 Connect I/O module (connection "LD") via data cable with leak detector (connection "I/O Anybus").
- 2 Connect I/O module via desired interfaces with external controller:
 - RS232 (RS-232 interface)
 - RS485 (RS-485 interface)
 - Analog in (analog inputs)
 - Analog out (analog outputs)
 - PLC IN, digital inputs
 - PLC OUT, digital outputs

5.2 Remove the I/O module from the DIN-TS35 top hat rail

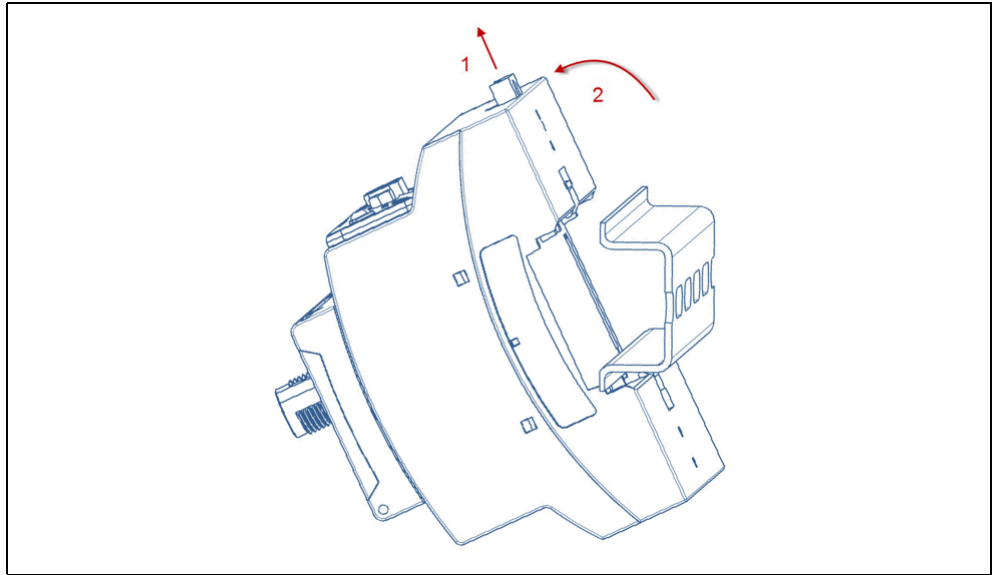

Fig. 7 Removing the I/O module

- 1 Use the flat-tip screwdriver to pull out the locking device.
- 2 Pull the device off of the top hat rail.

6 Disposal

The unit can be disposed of by the owner or sent to INFICON.

The unit is made of materials that can be reused. You should use this option to avoid waste and save the environment.

- ▶ For disposal, always comply with local and regional environmental and safety regulations.