

Chemtech Scientific provides access to this content as a courtesy.  
We do not own the content contained in this document.  
All rights and credit go directly to its rightful owners.  
[www.chemtechsci.com](http://www.chemtechsci.com)  
Call us at: 484-424-9415



# TURBOVAC

Turbomolecular pumps with grease-lubricated bearings

TURBOVAC 35 LS, 35 LS2

TURBOVAC 50

TURBOVAC 151, 151 C

TURBOVAC 361, 361 C

TURBOVAC 600 C

TURBOVAC 1000 C

and pumps modified by Oerlikon Leybold Vacuum

**Operating Instructions GA05118\_1502**



# Contents

	Page
<b>Important Safety Information</b>	<b>3</b>
<b>1 Description</b>	<b>6</b>
1.1 Design and Operation	6
1.2 Supplied Equipment	6
1.3 Technical Data	7
1.4 Ordering Information	12
1.5 Operating environment and cooling	13
<b>2 Transport and Storing</b>	<b>14</b>
<b>3 Installation</b>	<b>15</b>
3.1 Conforming Utilisation	15
3.2 Ambient Conditions	15
3.3 Connecting the pump to the vacuum chamber	16
3.4 Forevacuum connection	20
3.5 Connecting the cooling	20
3.6 Connecting the purge gas and airing device	22
3.7 Connecting the TURBOTRONIK	23
<b>4 Operation</b>	<b>24</b>
4.1 Media Compatibility / Purge Gases	24
4.2 Start-up	25
4.3 Bakeout	26
4.4 Operation	26
4.5 Switching Off	26
4.6 Venting	27
<b>5 Maintenance</b>	<b>29</b>
5.1 Maintenance Intervals	29
5.2 Oerlikon Leybold Vacuum Service	29
5.3 Cleaning	30
5.4 Removing the pump from the system	30
<b>6 Troubleshooting</b>	<b>31</b>
<b>7 Waste Disposal</b>	<b>33</b>
<b>EC Manufacturer's Declaration</b>	<b>34</b>

# Safety Information

## Important Safety Information

Indicates procedures that must be strictly observed to prevent hazards to persons.

Indicates procedures that must be strictly observed to prevent damage to, or destruction of the product.

The Oerlikon Leybold Vacuum **TURBOVAC** have been designed for safe and efficient operation when used properly and in accordance with these Operating Instructions. It is the responsibility of the user to carefully read and strictly observe all safety precautions described in this section and throughout the Operating Instructions. The TURBOVAC **must only be operated in the proper condition and under the conditions described in the Operating Instructions**. It must be operated and maintained by trained personnel only. Consult local, state, and national agencies regarding specific requirements and regulations. Address any further safety, operation and/or maintenance questions to our nearest office.

**Failure to observe the following precautions could result in serious personal injury!**

### Mechanical hazards

Risk of injury!

Avoid exposing any part of the human body to the vacuum. Only handle the pump when it is vented.

Turbopumps as described in the following operation manual contains a high portion of kinetic energy due to their high rotational speed in combination with the specific rotor mass.

In case of a malfunction of the system for example rotor/stator contact or even a rotor crash the rotational energy is released.

To avoid the destruction of the equipment and to prevent injuries of the operating staff the leading European manufacturers of vacuum pumps strictly recommend to follow the installation instructions as given in this manual!

Never operate the pump (in bench tests, for instance) without its being flanged to the vacuum chamber.

The small-flange connector for the high-vacuum flange at the TURBOVAC 50 is not strong enough to keep the pump from rotating if it should suddenly seize. Rotation of the pump can cause leaks in the forevacuum line. Secure the pump additionally to prevent rotation in case it should suddenly seize.

---

**Warning**

---

**Caution**

---

---

**Warning**



# Safety Information

---

## Warning



### Electrical hazards

Risk of injury!

Dangerous voltages are present at the mains connections. Before beginning with any maintenance or service work on the pump, disconnect the pump from all power supplies.

Operate the pump only with the matching frequency converter and connector line.

Voltages of up to 400 V will be present at the connection cable between the frequency converter and the pump; mains voltage will be present at the fan, the flange heater, the valves and their supply leads.

Route the conductors and cables so as to protect them from damage.

When the connector cable to the TURBOVAC is attached, the outputs of the TURBOTRONIK frequency converter are not free of voltage.

---

## Warning



### Thermal hazards

Risk of injury!

The pump can become so hot during operation ( $> 70^{\circ}\text{C}$ ,  $158^{\circ}\text{F}$ ) as to represent a burn hazard. Shield the hot components against contact.

Note the symbols on the pump pointing to the hazards, and in the case of a hot pump wear the required protective clothing.

---

## Warning



### Hazards caused by materials and substances

The forevacuum line must be tight.

Hazardous gases could escape from leaks or the gases being pumped could react with air or humidity.

Take the appropriate precautionary measures prior to opening the intake or discharge connection if the pump has previously handled hazardous gases.

If necessary, use gloves, a respirator and/or protective clothing and work under an exhaust hood.

Risk of explosion!

The standard version of the pump is **not suited** for operation in **explosion hazard areas**. Contact us before planning to use the pump under such circumstances.



Contaminated parts can be detrimental to health and environment. Before beginning with any work, first find out whether any parts are contaminated. Adhere to the relevant regulations and take the necessary precautions when handling contaminated parts.

---

# Safety Information

## Failure to observe the following precautions could result in damage to the pump!

Unauthorized opening of the pump or modifications of the mechanical or electrical components of the pump void the warranty.

The pump must only be opened by such persons who have been authorized by Oerlikon Oerlikon Leybold Vacuum Vacuum to do so.

The rotor is precision balanced; any change whatsoever, such as loosening or bending any rotor component, will make re-balancing necessary.

Unless appropriate accessories and attachments are used, the TURBO-VAC **is not** suitable for aggressive or corrosive media, or those containing dust. When handling corrosive media the C version pump must be operated with purge gas; when handling media containing dust, a fine-mesh filter must be installed.

Observe the information on media compatibility, to be found in Section 4.1.

Take care not to damage the plugs and coolant connections during movement.

Exposure of the pump to accelerating forces must be avoided or reduced to such an extent that the rotor unit will not be excited by vibrations. In the case of critical applications you must consult our Applications Dept. first.

The references to diagrams, e. g. (1/2) consist of the Fig. No. and the Item No. in that order.

We reserve the right to alter the design or any data given in these Operating Instructions. The illustrations are not binding.

Retain the Operating Instructions for further use.

---

## Caution

---

## Figures

# Description

## 1 Description

### 1.1 Design and Operation

The TURBOVAC models 35 LS to 1000 are turbomolecular pumps featuring grease-lubricated bearings. These units are engineered to pump vacuum chambers down to pressures in the high-vacuum range. A TURBOTRONIK frequency converter and a forevacuum pump are required for the operation of the TURBOVAC.

### 1.2 Supplied Equipment

The TURBOVAC is shipped in a sealed PE bag which also contains a desiccant. The maximum effective life of the desiccant is one year.

#### **TURBOVAC 35 LS / 35 LS2**

The pumps are shipped without splinter guard or connection accessories.

#### **TURBOVAC 50 to 1000**

For high-vacuum port with ISO-K flange:

Splinter guard, centering ring with FPM sealing ring; outer ring.

For high-vacuum port with CF flange: Splinter guard.

For high-vacuum port with KF flange: Splinter guard, centering ring with FPM O-ring and clamping ring.

For high-vacuum port with ANSI flange: Splinter guard.

Forevacuum port: Centering ring with O-ring and clamping ring.

Both the purge gas port and the airing port are blanked off for shipping.

In addition the pivoted threaded fittings used to make the coolant connection are included as standard equipment for the TURBOVAC 151, 361 and 600; if needed, they can be used to replace the hose nipples installed at the factory.

The electronic frequency converter and the connector cables required for operation are not included as standard equipment with the pump.

---

PE = Polyethylene

FPM = Fluoroelastomer, resistant to temperatures of up to 150°C (300 °F)

## 1.3 Technical Data

### Special Versions for Leak Detectors

TURBOVAC		35 LS	35 LS2
High-vacuum port	DN	40 KF	40 KF
Pumping speed			
He, high vacuum	$l \cdot s^{-1}$	25	32
He, interstage vacuum	$l \cdot s^{-1}$	4.5	5.5
Max. gas throughput in permanent operation with water cooling at $10^{-2}$ mbar,			
He	$mbar \cdot l \cdot s^{-1}$	0.25	0.25
Max. idle compression			
He, high vacuum		$1.5 \cdot 10^3$	$2 \cdot 10^4$
He, interstage vacuum		70	600
Max. forevacuum pressure for He	mbar	1	6
Forevacuum port	DN	16 KF	16 KF
Recommended forevacuum pump		TRIVAC D 2,5 E	Diaphragm pump
Run-up time to 95% nominal speed	min		2
Weight, approx.	kg		2
Max. power consumption / at ultimate pressure	W		45 / 15
Max. ambient temperature at operation	°C		45

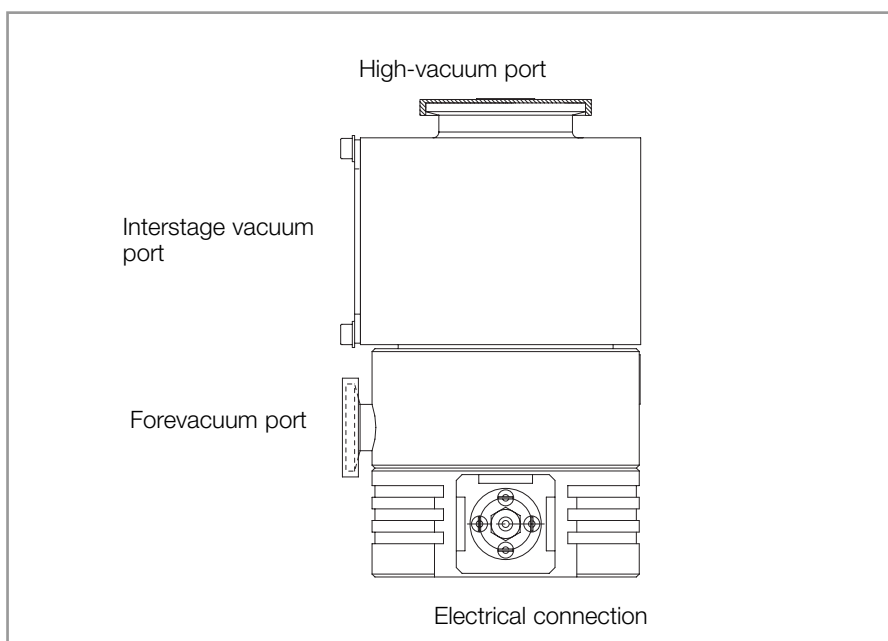

TURBOVAC 35 LS and 35 LS2

# Description

## TURBOVAC 50

High-vacuum port	DN	O-Ring sealed 40 KF	O-Ring sealed 63 ISO-K	Metal sealed 63 CF
Pump housing		Aluminium	Aluminium	Stainless steel
Pumping speed at $10^{-3}$ mbar				
N <sub>2</sub>	l · s <sup>-1</sup>	33	55	55
He	l · s <sup>-1</sup>	36	48	48
H <sub>2</sub>	l · s <sup>-1</sup>	28	30	30
Max. gas throughput in permanent operation with water cooling at $10^{-2}$ mbar				
N <sub>2</sub>	mbar · l · s <sup>-1</sup>	0.30	0.40	0.40
He	mbar · l · s <sup>-1</sup>	0.25	0.35	0.35
H <sub>2</sub>	mbar · l · s <sup>-1</sup>	0.20	0.25	0.25
Max. idle compression N <sub>2</sub>		$2 \cdot 10^6$	$2 \cdot 10^6$	$2 \cdot 10^8$
Ultimate pressure with TRIVAC D 2,5 E	mbar	$< 5 \cdot 10^{-8}$	$< 5 \cdot 10^{-8}$	$< 5 \cdot 10^{-8}$
Max. forevacuum pressure for N <sub>2</sub>			$1 \cdot 10^{-1}$	
Forevacuum port	DN		16 KF	
Recommended forevacuum pump			TRIVAC D 2,5 E	
Run-up time to 95% nominal speed	min		2	
Cooling water connection (hose nozzle) (for Part No. 854 08)	mm		10	
Weight, approx.	kg		2	
Max. power consumption / at ultimate pressure W			45 / 15	
Max. ambient temperature at operation	°C		55	
Max. bakeout temperature at CF flange	°C		80	

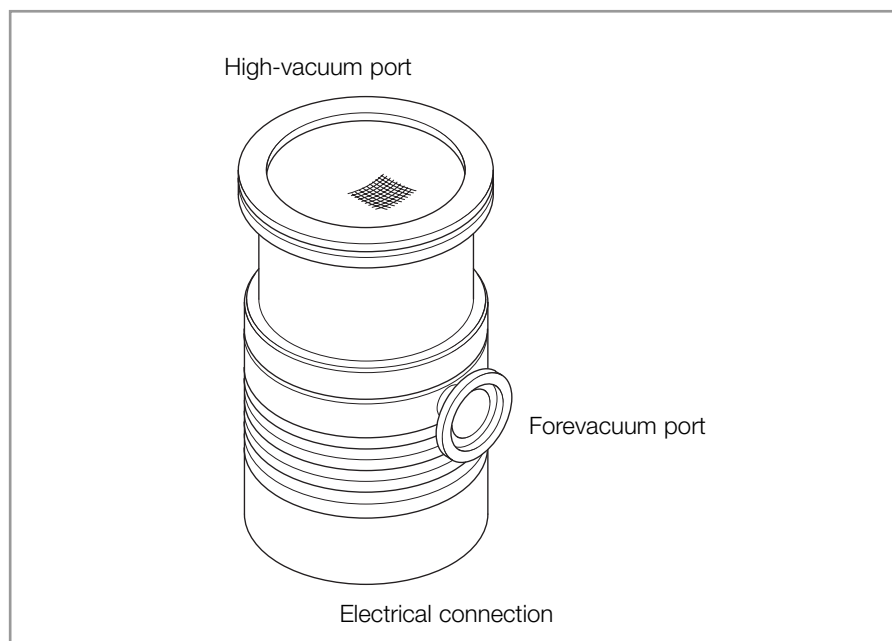

TURBOVAC 50



# Description

		<b>TURBOVAC 151</b>		<b>TURBOVAC 361 / 361 C</b>	
High-vacuum port		DN	100 ISO-K / 100 CF	100 ISO-K • 100 CF	160 ISO-K • 160 CF
Pumping speed	N <sub>2</sub>	l · s <sup>-1</sup>	145	345	400
	Ar	l · s <sup>-1</sup>	150	350	–
	He	l · s <sup>-1</sup>	135	340	380
	H <sub>2</sub>	l · s <sup>-1</sup>	115	340	370
Max. gas throughput	N <sub>2</sub>	mbar · l · s <sup>-1</sup>	3	7.5	–
	Ar	mbar · l · s <sup>-1</sup>	3	7.5	–
	H <sub>2</sub>	mbar · l · s <sup>-1</sup>	1.7		
Compression	N <sub>2</sub>		1 · 10 <sup>9</sup>	1 · 10 <sup>9</sup>	
	He		2 · 10 <sup>4</sup>	6 · 10 <sup>4</sup>	
	H <sub>2</sub>		8 · 10 <sup>2</sup>	3 · 10 <sup>3</sup>	
Ultimate pressure		mbar	< 1 · 10 <sup>-10</sup>	< 1 · 10 <sup>-10</sup>	
Max. Inlet pressure (permanent) with water cooling		mbar	5 · 10 <sup>-2</sup>	5 · 10 <sup>-2</sup>	
Max. forevacuum pressure for N <sub>2</sub>		mbar	5 · 10 <sup>-1</sup>	5 · 10 <sup>-1</sup>	
Recommended forevacuum pump		TRIVAC	D 4 B to D 16 B	D 16 B to D 25 B	
Run-up time to 95% nominal speed		min	≈ 2	≈ 2	
Forevacuum port		DN	25 KF	25 KF	
Purge gas / vent port		DN	10 KF	10 KF	
Cooling water connection (hose nozzle)		mm	10	10	
Weight, approx.		kg	8	12	
Max. power consumption / at ultimate pressure	VA		680 / 480	680 / 480	
Max. ambient temperature at operation		°C	55	55	
Max. bakeout temperature at CF flange		°C	100	100	

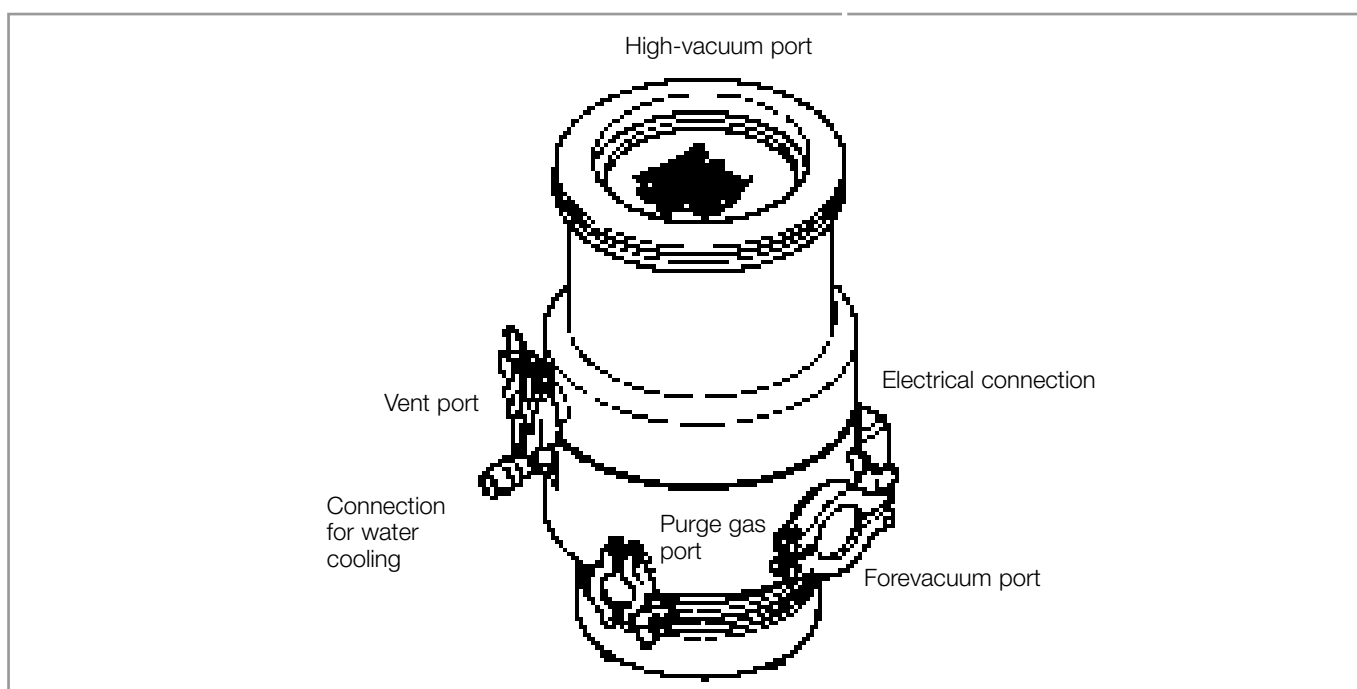

TURBOVAC 151 C; TURBOVAC 361 C similar

# Description

## TURBOVAC 600 C

## TURBOVAC 1000 C

High-vacuum port	DN		160 ISO-K • 160 CF	160 ISO-K/CF	200 CF/6" ANSI	250 ISO-K
Pumping speed	N <sub>2</sub>	l · s <sup>-1</sup>	560	850	1100	1150
	He	l · s <sup>-1</sup>	600	-	-	-
	H <sub>2</sub>	l · s <sup>-1</sup>	570	-	-	-
Max. gas throughput	N <sub>2</sub>	mbar · l · s <sup>-1</sup>	< 4		-	
	Ar	mbar · l · s <sup>-1</sup>	< 4		-	
Compression	N <sub>2</sub>		> 10 <sup>9</sup>		-	
	He		2 · 10 <sup>4</sup>		-	
	H <sub>2</sub>		1.1 · 10 <sup>3</sup>		-	
Ultimate pressure		mbar	< 10 <sup>-10</sup>		< 10 <sup>-10</sup>	
Speed		rpm	36,000		36,000	
Run-up time (freq. converter), approx.		min	4		9	
Max. Inlet pressure (permanent) with water cooling		mbar	1 · 10 <sup>-2</sup>		-	
Max. forevacuum pressure for N <sub>2</sub>		mbar	5 · 10 <sup>-2</sup>		5 · 10 <sup>-2</sup>	
Recommended forevacuum pump at standard operation		TRIVAC	D 25 B / 40 B		TRIVAC D 40 B	
at purge gas operation		TRIVAC	40 B			
Run-up time to 95% nominal speed		min	3		-	
Forevacuum port	DN		40 KF	40 KF/63 ISO-K	40 KF	40 KF/63 ISO-K
Purge gas / vent port	DN		10 KF	10 KF <sup>1)</sup>	10 KF <sup>1)</sup>	10 KF <sup>1)</sup>
Cooling water connection (hose nozzle)	mm		10	11 / 10 <sup>2)</sup>	11	11 / 10 <sup>2)</sup>
Weight, approx.		kg	12		25	
Max. power consumption / at ultimate pressure		VA	680 / 480		-	
Max. ambient temperature at operation		°C	55		55	
Max. bakeout temperature at CF flange		°C	100		100	

1) As of 1995 in some cases 16 mm KF

2) 11 mm with 40 mm type KF forevacuum port  
10 mm with 63 mm type ISO-K forevacuum port

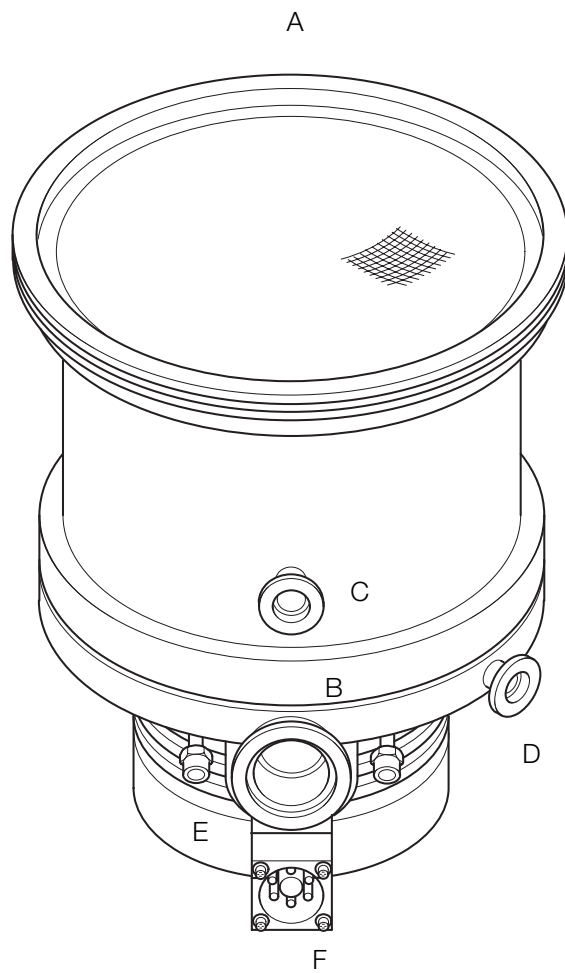

TURBOVAC 600 C

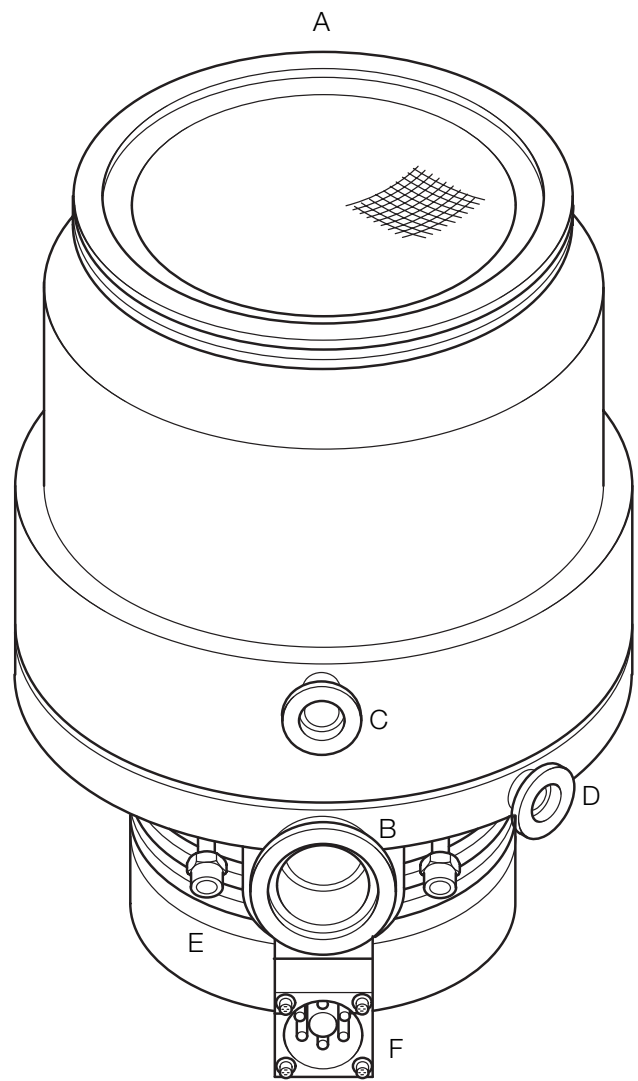

TURBOVAC 1000 C

- A High-vacuum port
- B Forevacuum port
- C Vent port
- D Purge gas port
- E Connection for water cooling
- F Electrical connection

Fig. 2

# Description

## 1.4 Ordering Information

TURBOVAC	35 LS	35 LS 2	50	151	151 C	361	361 C	600 C	1000 C
----------	-------	---------	----	-----	-------	-----	-------	-------	--------

### High-vacuum port

DN 40 KF	856 64	856 66	854 00						
DN 40 CF			853 99						
DN 63 ISO-K			854 01						
			800150V0010						
DN 63 CF			854 02						
DN 100 ISO-K				856 31	856 35	856 70	856 75		
						800150V0005 <sup>3)</sup>	800150V0018 <sup>4)</sup>		
DN 100 CF				856 32	103 41	856 71			
DN 160 ISO-K						856 72	856 77	800150V0015	855 35 <sup>1)</sup> 855 38 <sup>2)</sup>
DN 160 CF						856 73		800150V0017	854 91 <sup>1)</sup>
DN 200 CF									117 64 <sup>1)</sup>
DN 200 ISO-K									153 00 <sup>1)</sup>
6" ANSI									894 89 <sup>1)</sup>
DN 250 ISO-K									855 36 <sup>1)</sup> 855 39 <sup>2)</sup>
Cooling water unit for TURBOVAC 35 LS, 35 LS2, 50			854 08						

- 1) With forevacuum flange DN 40 KF
- 2) With forevacuum flange DN 63 ISO-K
- 3) Venting flange, turned by 180°
- 4) Clean room packaging

## 1.5 Operating environment and cooling

TURBOVAC	No additional cooling required if all these conditions are satisfied	Air or water cooling required	Water cooling required if any one of these conditions prevails
35 LS 35 LS2	Ambient temperature < 30° C No bakeout operations High-vacuum pressure < 10 <sup>-3</sup> mbar Forevacuum pressure < 5·10 <sup>-1</sup> mbar	Ambient temperature 30 - 40 °C Bakeout operations High-vacuum pressure 10 <sup>-3</sup> to 5·10 <sup>-2</sup> mbar Forevacuum pressure 5·10 <sup>-1</sup> to 2 mbar	Ambient temperature 40 - 45 °C Bakeout operations High-vacuum pressure > 5·10 <sup>-2</sup> mbar Forevacuum pressure > 2 mbar
50	Continuous operation at high-vacuum pressure < 10 <sup>-4</sup> mbar Ambient temperature < 45 °C	Bakeout at ambient temperature < 40 °C Continuous operation at high-vacuum pressure > 10 <sup>-4</sup> mbar Rapid-cycling operation	Ambient temperature 45 - 55 °C Bakeout at ambient temperature > 40° C
151, 151 C, 361, 361 C	—	Bakeout at ambient temperature < 35 °C or High-vacuum pressure < 10 <sup>-3</sup> mbar and ambient temperature < 45 °C	Bakeout at ambient temperature > 35 °C High-vacuum pressure > 10 <sup>-3</sup> mbar Ambient temperature 45 - 55 °C
600 C	—	Bakeout at ambient temperature < 35 °C or high-vacuum pressure < 10 <sup>-3</sup> mbar and ambient temperature < 45 °C	Bakeout at ambient temperature > 35 °C High-vacuum pressure > 10 <sup>-3</sup> mbar Ambient temperature 45 - 55 °C
1000 C	—	Bakeout at ambient temperature < 35° C or high-vacuum pressure < 10 <sup>-4</sup> mbar and ambient temperature < 45 °C	Bakeout at ambient temperature > 35 °C High-vacuum pressure > 10 <sup>-4</sup> mbar Ambient temperature 45 - 55 °C

°C	°F	mbar	Torr
30	86	10 <sup>-4</sup>	8·10 <sup>-5</sup>
35	95	10 <sup>-3</sup>	8·10 <sup>-4</sup>
40	104	10 <sup>-2</sup>	8·10 <sup>-3</sup>
45	113	5·10 <sup>-2</sup>	4·10 <sup>-2</sup>
50	122	5·10 <sup>-1</sup>	4·10 <sup>-1</sup>
55	131	2	1.5

# Transport and Storing

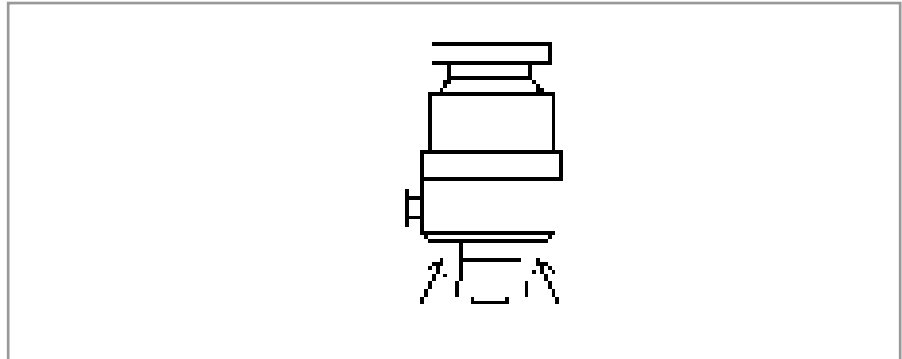

Fig. 3 Transportation

## 2 Transport and Storing

When moving the heavier pumps, the lower surfaces on the base flange are suitable for accepting a lifting fork; see Fig. 3.

---

**Caution**

---

Take care not to damage the plugs and coolant connections during movement.

The TURBOVAC is shipped in a sealed PE bag which also contains a desiccant. The maximum effective life of the desiccant is one year.

Do not open the packaging until immediately prior to installation.

## 3 Installation

### 3.1 Conforming Utilisation

The TURBOVAC models are engineered to pump vacuum chambers down to pressures in the high-vacuum range. A TURBOTRONIK frequency converter and a forevacuum pump are required for the operation of the TURBOVAC.

The TURBOVAC 35 LS and 35 LS2 are only intended for integration into a Helium leak detector.

These units are **not** suitable for operation without a forevacuum pump.

Turbomolecular pumps are **not** suitable for pumping either gases which contain dust particles or liquids.

Turbomolecular pumps without a purge gas feature are suitable only for moving air or inert gases. They are not suitable for pumping aggressive or reactive gases.

TURBOVAC versions identified with a "C" in the model number are equipped with this purge gas feature, it protects only the bearing area and the motor in the TURBOVAC.

### 3.2 Ambient Conditions

When using the TURBOVAC inside a magnetic field, the magnetic induction at the pump housing surface may not exceed the following values:

**TURBOVAC 50:**  $B = 7 \text{ mT}$

**TURBOVAC 151 – 1000:**

$B = 5 \text{ mT}$  in case of radial impingement

$B = 15 \text{ mT}$  in case of axial impingement

Provide suitable shielding measures if these values are exceeded.

The standard version is resistant to radiation at levels up to  $10^3 \text{ Gy}$ .

## Magnetic field

---

1 mT (milliTesla) = 10 G (Gauss)

1 Gy (Gray) = 100 rad

# Installation

### 3.3 Connecting the pump to the vacuum chamber

Remove the covers and the blank flanges at the turbomolecular pump only just before installing, to ensure that the TURBOVAC is installed under the cleanest possible conditions.

Do not stand below the TURBOVAC pump while it is being connected to or detached from the system.

---

#### Warning



Turbopumps as described in the following operation manual contains a high portion of kinetic energy due to their high rotational speed in combination with the specific rotor mass. In case of a malfunction of the system for example rotor/stator contact or even a rotor crash the rotational energy is released.

To avoid the destruction of the equipment and to prevent injuries of the operating staff the leading European manufacturers of vacuum pumps strictly recommend to follow the installation instructions as given in this manual!

The high-vacuum flange must be securely attached to the vacuum chamber. If the pump were to become blocked, insufficient attachment could cause the pump to break away from its mount or allow internal pump parts to be discharged. Never operate the pump (in bench tests, for instance) without its being flanged to the vacuum chamber.

If the pump should suddenly seize, the ensuing deceleration torque will have to be absorbed by the system. To accomplish this, the following are required when securing an ISO-K type high-vacuum flange:

TURBOVAC	Braking torque [Nm]	Clamping bolts
35 LS / LS2	150	4
50	63	4
151/151 C	283	4
361/361 C	580	6
600 C	1486	10
1000 C DN 160	1500	16
DN 250	1500	10

Clamping bolts made of steel must be torqued down to 35 Nm, those of quality 12.9 to 50 Nm.

When installing CF flanges, use only the bolts specified (tightening torque is 15 Nm for DN 40 CF, 30 Nm for DN 63 CF and larger).

You will find the order numbers for the (clamping) bolts in the Oerlikon Oerlikon Leybold Vacuum Catalog.

The clamping bolts are **not** included as standard equipment with the pump.

Nm	15	30	35	50
ft-lb	11	22	26	37



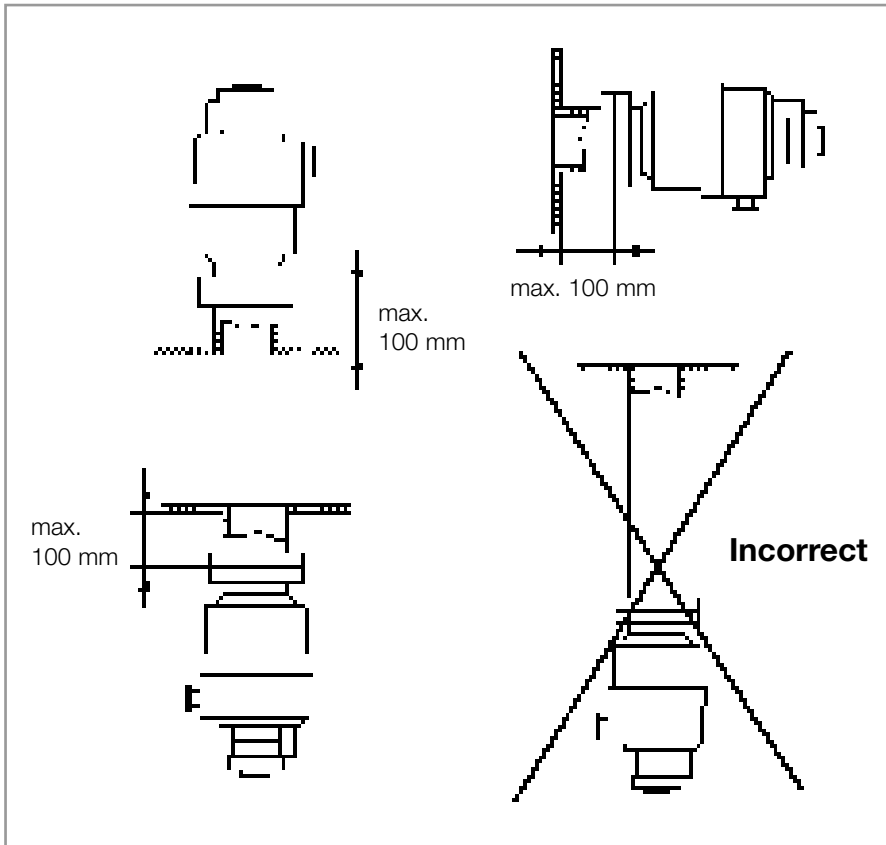

Fig. 4 Fixed flanging of the TURBOVAC to the vacuum chamber

The small-flange connector for the high-vacuum flange at the TURBOVAC 50 is not strong enough to keep the pump from rotating if it should suddenly seize. Rotation of the pump can cause leaks in the forevacuum line. Secure the pump additionally to prevent rotation in case it should suddenly seize.

## Warning



In most applications the TURBOVAC will be flanged direct to the high-vacuum flange for the system. The design of the lubricating system makes it possible to mount and run the TURBOVAC in any desired attitude. It is not necessary to support the pump.

If there is a danger that dust could pass from the vacuum chamber into the TURBOVAC, install a fine-mesh filter between the vacuum chamber and the TURBOVAC.

## Fine-mesh filter

The TURBOVAC is precision balanced and is generally operated without a vibration damper. A special-design vibration damper is available for mounting at the TURBOVAC high-vacuum flange to decouple extremely sensitive equipment and to prevent external vibrations from being transferred to the TURBOVAC. If the TURBOVAC 1000 C are flanged via a vibration damper secure it in addition at the base flange.

## Vibration damper

# Installation

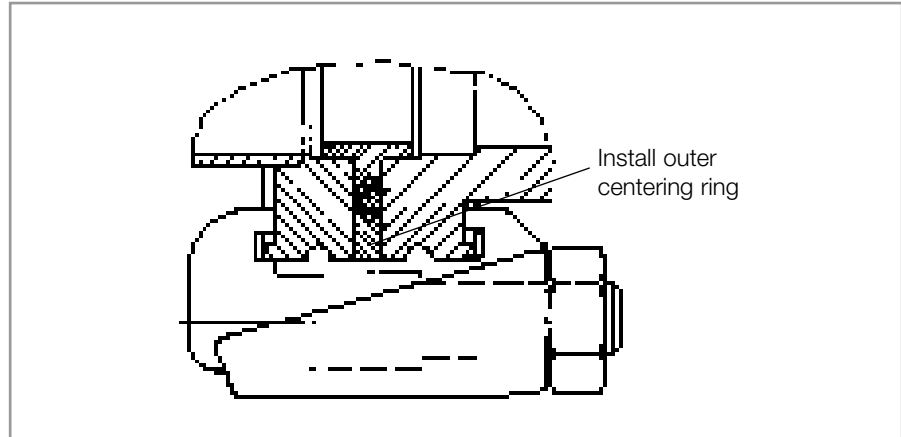

Fig. 5 Using ISO-K flanges

## **Design with ISO-K clamp flange**

Fit the O-ring at the centering ring.

The O-ring should be flat and even; it must not be twisted. Then add the outer ring.

A collar flange with retaining ring and suitable sealing washer can also be used to connect the TURBOVAC.

A collar flange is required when using ultra-high-vacuum sealing washers.

## **Splinter guard**

A splinter guard is installed in the high-vacuum flange to protect the TURBOVAC.

Operate the pump only with this splinter guard in place as foreign objects passing through the intake port and into the pump can cause serious damage to the rotor. Damage caused by foreign objects in the rotor section is excluded from the guarantee.

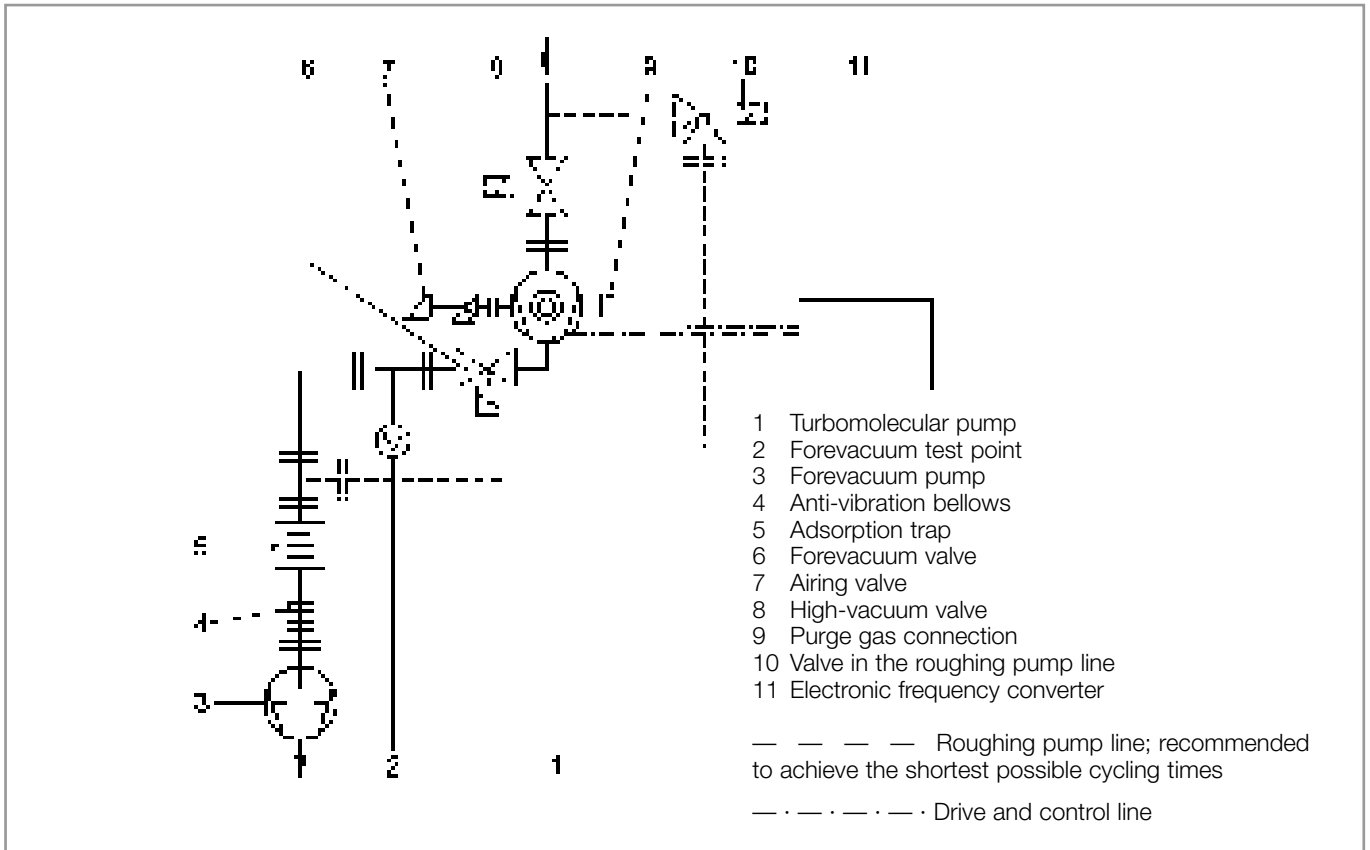

Fig. 6 Schematic of a turbomolecular pump system

## Flange heating

(only for pumps with the CF flange)

The flange heater is used to bake out, under automatic control, the high-vacuum connection port at the TURBOVAC and the mating flange on the vacuum chamber.

The bakeout jacket or flange heater is mounted directly to the TURBOVAC intake flange. This can be done even with the pump flanged to the vacuum chamber.

Risk of injury!

The pump can become so hot during operation ( $> 70^{\circ}\text{C}$ ,  $158^{\circ}\text{F}$ ) as to represent a burn hazard. Shield the hot components against contact.

**Warning**



The pump running noise is below 70 dB(A); no noise-insulating measures are required.

# Installation

## Forevacuum pump

### 3.4 Forevacuum connection

A suitable forevacuum pump is to be connected to the forevacuum connection flange.

Fig. 6 shows schematically the design of a pump system incorporating a TURBOVAC turbomolecular pump and a TRIVAC forevacuum pump with anti-suckback valve.

## Anti-suckback valve

When using a forevacuum pump not having an anti-suckback valve, a separate safety valve should be provided. The safety valve keeps oil from back-streaming from the forevacuum pump and into the TURBOVAC when the system is not running.

## Sorption trap

We recommend installing a sorption trap in the forevacuum line to insure that the forevacuum chamber in the TURBOVAC remains largely free of oil vapors during operation, as well.

Install a roughing pump line to achieve the shortest possible cycling times.

Be sure that there is sufficient vibration decoupling between the TURBOVAC and the forevacuum pump.

---

## Warning



The forevacuum line must be tight.

Hazardous gases could escape from leaks or the gases being pumped could react with air or humidity.

### 3.5 Connecting the cooling

#### Air cooling

The air cooling unit is available as a supplementary kit for retrofitting.

When installing the air-cooled TURBOVAC, ensure that there is an unrestricted flow of air to the fan.

Always maintain a minimum distance of 20 cm (8 inch) to the nearest object.

Ensure that no heated air from neighboring equipment will be drawn in by the fan.

Connect the fan in the air ventilation unit to the AC mains.

Make the electrical connection for the ventilation unit in such a way that it will be started and stopped together with the pump itself.

Observe the information given in the operating instructions for the air ventilation unit (GA 05.199).

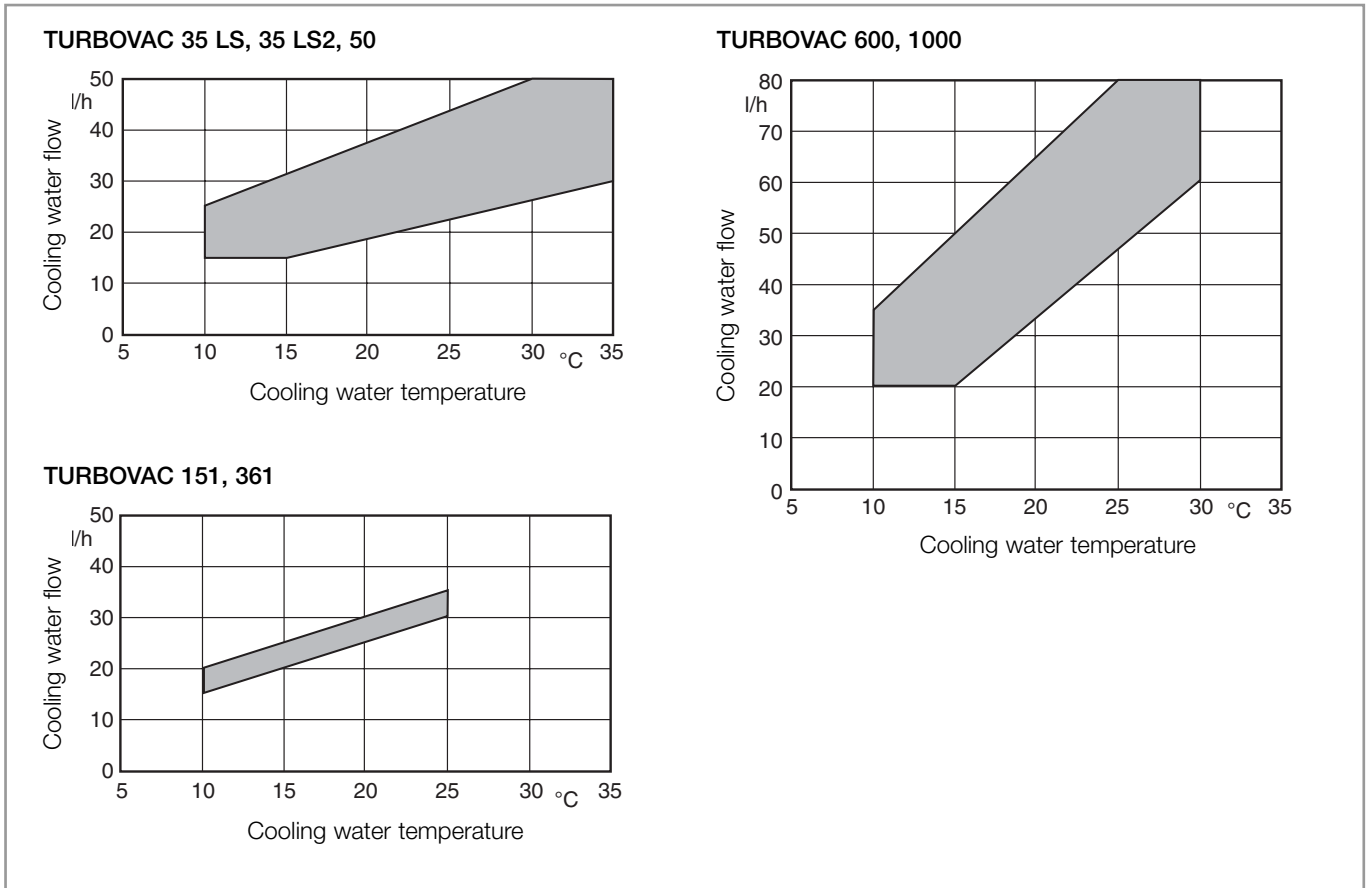

Fig. 7 Cooling water consumption

## Water cooling

When attaching the water cooling unit to the TURBOVAC 35 LS, 35 LS2 and 50, remove the pump foot and then bolt the cooling unit to the bottom of the pump. The mounting bolts are provided with the water cooling unit.

Connect the coolant hoses to the hose nipples and secure with hose clamps.

If the coolant flow is turned on and off by means of a solenoid valve, make the electrical connection in such a way that coolant flow will be started and stopped together with the pump itself.

## Cooling water specifications

Inlet pressure	3 to 7 bar absolute
Cooling water requirement, inlet temperature	See Fig. 7
Appearance	Colorless, clear, free of oils and greases
Sediments	< 250 mg/l
Particle size	< 150 µm
pH value	7 to 8.5
Overall hardness (total alkaline earths)	max. 20 ° German hardness scale (= 3.57 mmol/l)

# Installation

## **3.6 Connecting the purge gas and airing device**

See Section 4.1 for suited gases, see Section 4.6 for different venting methods.

### **TURBOVAC 35 LS, 35 LS2 and 50 with KF or ISO-K connectors**

The TURBOVAC is aired through the system.

### **TURBOVAC 50 with CF connector and 151, 361**

If the pump cannot be aired through the system, then a power failure airing valve shall be attached to the airing connection flange. This power failure airing valve prevents oil vapor from the forevacuum line from diffusing back into the system.

### **TURBOVAC 151 C, 361 C, 600 C and 1000 C**

Either attach a power failure airing valve to the airing connection flange or a purge gas and airing valve at the purge gas connection flange.

Which of the two flanges is used will depend on the process.

When pumping **clean, non-corrosive gases**, a power failure airing valve is to be attached.

When pumping **reactive media**, connect a purge gas and airing valve.

Please contact Oerlikon Leybold Vacuum for assistance in making the decision as to which media can be pumped with or without purge gas.

In processes which require purge gas the pump will have to be aired, when it is switched off, through the purge gas valve.

Observe the operating instructions for the purge gas and airing valve.

## 3.7 Connecting the TURBOTRONIK

Use the connector cable to attach the TURBOVAC and the TURBOTRONIK; see the operating instructions on the TURBOTRONIK for details.

Risk of injury!

Dangerous voltages are present at the mains connections. Before beginning with any maintenance or service work on the pump, disconnect the pump from all power supplies.

Operate the pump only with the matching frequency converter and connector line.

Voltages of up to 400 V will be present at the connection cable between the frequency converter and the pump; mains voltage will be present at the fan, the flange heater, the valves and their supply leads.

Route the conductors and cables so as to protect them from damage.

The connections are of the IP 40 safety classification. Do not expose the pump, frequency converter or connectors to dripping water.

The TURBOVAC **35 LS** and **35 LS2** are special pumps designed specifically for leak detectors. These pumps **must not** be operated in connection with the standard frequency converters NT 10, NT 12 or NT 13 (P/N 859 00 /01 /04 /05 /06 /07) or the standard cables for the TURBOVAC 50. For the TURBOVAC 35 LS and 35 LS2 exclusively the modified frequency converter SO-NT 12 (Ref. No. 200 99 042) and the corresponding cable (Ref. No. 200 61 626) must be used.

---

### Warning



# Operation

## 4 Operation

### 4.1 Media Compatibility / Purge Gases

---

**Caution**

Unless appropriate accessories and attachments are used, the TURBO-VAC **is not** suitable for aggressive or corrosive media, or those containing dust. When handling corrosive media the C version pump must be operated with purge gas; when handling media containing dust, a fine-mesh filter must be installed.

Some media (such as aluminum trichloride) can sublime inside the pump and form deposits. Thick deposits reduce the play between moving parts to the point that the pump could seize. In some processes deposits can be prevented by heating the pump. Please consult with us in case such problems arise.

Corrosive gases (such as chlorine) can destroy the rotors.

**Danger of ignition**

During operation the pressure inside the TURBOVAC is so low that there is no danger of ignition (at pressures below about 100 mbar, 75 Torr). A hazardous condition will be created if flammable mixtures enter the hot pump at pressures above 100 mbar (75 Torr). During operation the pump can reach temperatures as high as 120°C (248 °F). Sparks could occur in case of damage to the pump and these could ignite explosive mixtures.

We would be glad to consult with you as regards the media which can safely be handled with this unit.

**Suited gases****Purge gas**

Suited are all gases,

- which will not cause corrosion or pitting in aluminium and steel and
- which in connection with process deposits in the pump will not cause corrosion or sticking.

For venting and as the purge gas we recommend inert gases like nitrogen or argon. The temperature of these gases should be between 5 °C and 80 °C , max. relative humidity should not exceed 10 ppm.

In individual cases and after consultation also dry, filtered, oil-free air or filtered ambient air may be used (filter mesh < 1µm).

**Filters**

Change the filters after some time, at least annually.



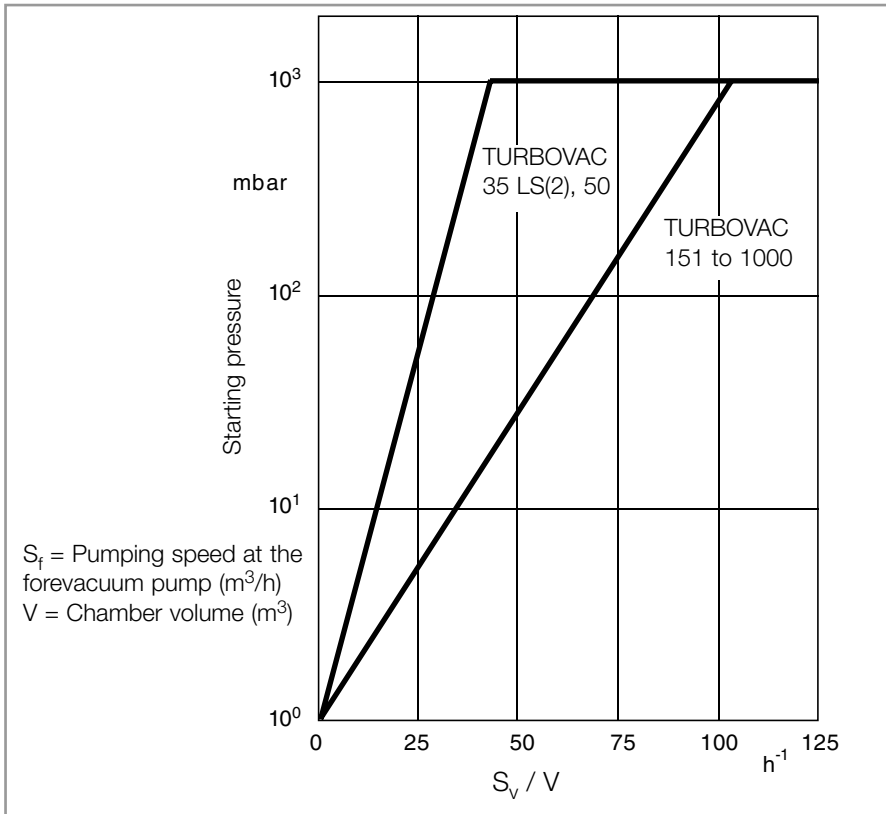

Fig. 8 Determining the starting pressure for a TURBOVAC when evacuating larger volumes

## 4.2 Start-up

The starting pressure for the TURBOVAC can be read from the chart reproduced in Fig. 8.

Where  $S_f / V > 100[\text{h}^{-1}]$ , the forevacuum pump and the TURBOVAC can be switched on simultaneously.

In such a situation the TURBOVAC serves from the very outset as an effective baffle.

When dealing with larger volumes, the vacuum chamber will first have to be pumped down with the forevacuum pump.

Then switch on the cooling and the TURBOVAC (at the TURBOTRONIK).

Kindly refer to the TURBOTRONIK operating instructions for details.

Avoid impact and vibration while the pump is running.

## Starting pressure

## Vibrations

# Operation

## 4.3 Bakeout

If pressures in the range of  $10^{-8}$  mbar are to be developed within a short period of time, the vacuum chamber and the components installed therein will have to be baked out. In addition, the TURBOVAC can be baked out using the flange heater provided for this purpose.

Protect the rotor against intensive, direct heat radiation. When baking out at the forevacuum side – at a sorption trap, for example – ensure that the components attached direct are not heated to more than 80 °C (176 °F).

The forevacuum pump must be in operation so as to eliminate the vapors liberated at the sorption trap.

## 4.4 Operation

---

### Warning



Risk of injury!

The pump can become so hot during operation (> 70°C, 158 °F) as to represent a burn hazard. Note the symbols on the pump pointing to the hazards, and in the case of a hot pump wear the required protective clothing.

---

### Caution

Exposure of the pump to accelerating forces must be avoided or reduced to such an extent that the rotor unit will not be excited by vibrations. In the case of critical applications you must consult our Applications Dept. first.

---

## 4.5 Switching Off

Switch off the TURBOVAC at the TURBOTRONIK.

Refer to the TURBOTRONIK operating instructions for details.

Switch off the forevacuum pump.

### Venting

Vent the TURBOVAC before it has come to a full standstill; refer to Section 4.6.

In TRIVAC pumps the built-in anti-suckback valve will close automatically and shut off the forevacuum line. When using forevacuum pumps without an anti-suckback valve, close the valve in the forevacuum line.

Close off the cooling water supply or switch off the ventilation immediately after switching off the TURBOVAC in order to avoid condensate formation in the pump.

If the pump previously handled corrosive gases, it will be necessary to purge the pump with dry nitrogen for one hour prior to shut-down. When the system is not in operation, ensure that neither ambient air nor cleaning agents can enter the TURBOVAC.

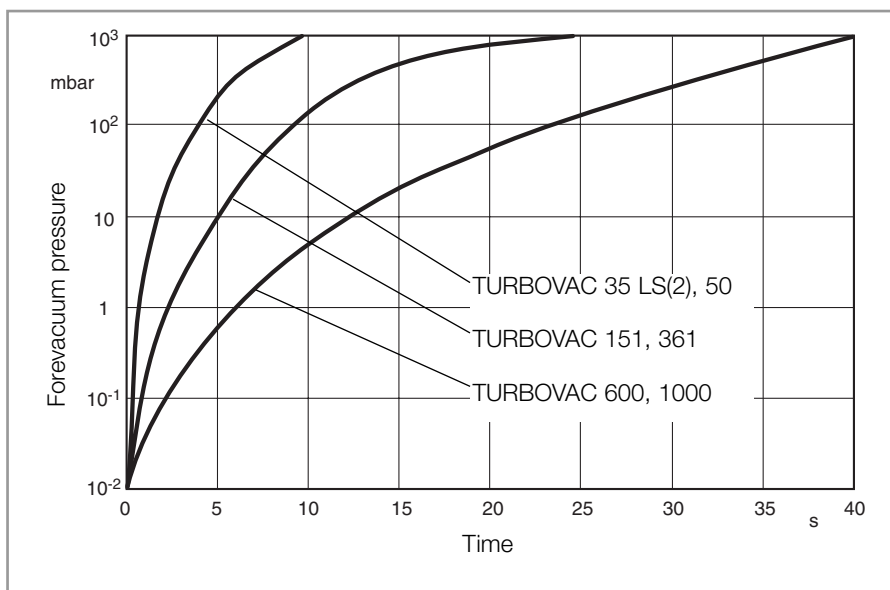

Fig. 9 Curves showing the pressure rise

## 4.6 Venting

As to suitable gases, see Section 4.1.

### Venting Methods

There are three different methods of venting the turbomolecular pump.

In the case processes requiring a purge gas, the pump must be vented via the purge gas and venting valve when shutting the pump down.

When additionally venting the vacuum chamber, the venting function of the purge gas and venting valve must be opened before opening the chamber valve. This will ensure the presence of a higher pressure in the area of the ball bearings compared to the remaining vacuum area. This will prevent particles, dust or aggressive gases from being forced through the bearings into the not yet vented motor chamber of the pump.

Cautious venting of the pump is possible from the high vacuum side, since here the bearing forces will be lowest. When doing so, no free jet of gas must be allowed to form on the rotor so as to avoid exposing the rotor to additional forces.

When venting the pump through its foreline connection, neither oil nor particles may be entrained in the gas flow from the forevacuum side into the pump.

### Purge gas and venting valve

### High vacuum side

### Foreline connection

# Operation

	<b>Speed of the Pressure Rise</b>
<b>Speed</b>	All turbomolecular pumps may be vented at full speed. However, the pressure must not increase faster than specified through the pressure rise curve.
<b>Pressure rise curve</b>	
<b>Particles</b>	The pump must be vented significantly slower when there is the risk of particles entering into the pump from the process. During venting, the flow must be of the laminar type in both the vacuum chamber and the turbomolecular pump.  The speed of the pressure rise during venting of the running pump will greatly influence the load on the rotor/stator pack and the bearings. The slower the pump is vented, the longer the service life of the bearings will be.  The pump must not be vented to pressures above atmospheric pressure.

## 5 Maintenance

The pump must only be opened by such persons who have been authorised by Oerlikon Leybold Vacuum to do so.

### 5.1 Maintenance Intervals

After 15,000 operating hours at the latest a standard bearing exchange will be recommended for the TURBOVAC 35 to 361 C. For the TURBOVAC 600 C and 1000 C a standard bearing exchange will be required after 10,000 operating hours at the latest.

Moreover we recommend to have the rotor assy. exchanged, depending on the thermal stress on the rotor, after 45,000 to 100,000 operating hours. This can only be done by Oerlikon Leybold Vacuum Service. For this ask for a quotation.

#### When using purge gas valves

Depending on the degree of contamination of the purge gas used the filter will clog and will have to be exchanged (our experience indicates that this will become necessary after 1 to 6 months).

#### When using an adsorption trap

Regenerate or renew the adsorption agent regularly; refer to the operating instructions provided with the trap.

### 5.2 Oerlikon Leybold Vacuum Service

Whenever you send us in equipment, indicate whether the equipment is contaminated or is free of substances which could pose a health hazard. If it is contaminated, specify exactly which substances are involved. You must use the form we have prepared for this purpose.

A copy of the form has been reproduced at the end of these Operating Instructions: "Declaration of Contamination for Compressors, Vacuum Pumps and Components". Another suitable form is available from [www.oerlikon.com](http://www.oerlikon.com) → Oerlikon Leybold Vacuum Systems → Documentation → Download Documents.

Attach the form to the equipment or enclose it with the equipment.

This statement detailing the type of contamination is required to satisfy legal requirements and for the protection of our employees.

We must return to the sender any equipment which is not accompanied by a contamination statement.

---

## Caution

---

### Standard bearing exchange

## Contamination

### Form

# Maintenance

## 5.3 Cleaning

Contamination inside the TURBOVAC is indicated by a deterioration in performance, i.e. an increasing decline in working pressure.

If there is only slight contamination, such as a coating on the TURBOVAC interior surfaces due to exposure to the atmosphere over an extended period of time, for the CF version the flange heater can be used for cleaning.

The ultimate pressure must be monitored while baking out under vacuum.

When making the initial examination of the pump, mount blank flanges to eliminate any possibility of leaks and desorption in the vacuum chamber.

The pump will have to be disassembled if there is more extensive contamination. The Oerlikon Leybold Vacuum Customer Service Department will have to be consulted here in all cases.

---

### Caution

The rotor is precision balanced; any change whatsoever, such as loosening or bending any rotor component, will make re-balancing necessary.

---

## 5.4 Removing the pump from the system

Switch off the pump and vent it as per the instructions in Sections 4.5 and 4.6.

---

### Warning

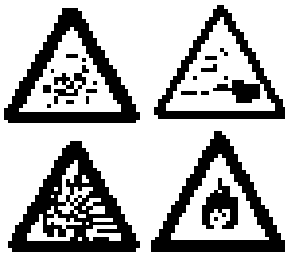

Take the appropriate precautionary measures prior to opening the intake or discharge connection if the pump has previously handled hazardous gases.

If necessary, use gloves, a respirator and/or protective clothing and work under an exhaust hood.

If the pump previously handled corrosive gases, then allow the purge gas to flow for as long as possible before detaching the pump from the system.

Remove the TURBOVAC from the system.

TURBOVAC pumps which are used in semiconductor processes, for example, will be contaminated with process gases. These gases may be toxic and hazardous to health. In addition, deposits with similarly dangerous properties may have formed. Many of these gases and deposits form acids when they come into contact with humid air. This will result in serious corrosion damage to the pump.

To avoid health hazards and corrosion damage when the pumps are detached from the system, lay a container of desiccant on the splinter guard and then close the pump immediately at all flange connections. Store the pump, with a desiccant, in a PE bag.

### Hazardous gases

### Deposits

### Desiccant

### Close the pump

# Maintenance / Troubleshooting

A packing set is included with TURBOVAC models with a "C" in the type designation. Use this packing set after detaching the pump from the system.

Faulty (leaky) packing of a TURBOVAC will nullify the guarantee.

## Ordering data

Packing set for high-vacuum connection flange	Order No.
DN 100/160	200 91 240
DN 200	200 91 295
DN 250, 6" ANSI	200 91 262

Pack the pump so that it cannot be damaged during shipping and so that no contaminants can escape from the packaging. Protect in particular the flanges, the coolant connection nipples and the cable grommets.

If you return a pump to Oerlikon Leybold Vacuum, be absolutely sure to observe the instructions given in Section 5.2.

## 6 Troubleshooting

When the connector cable to the TURBOVAC is attached, the outputs of the TURBOTRONIK frequency converter are not free of voltage.

---

### Warning



Before commencing troubleshooting procedures, make the following simple checks:

- Is the TURBOVAC being supplied with electrical energy?
- Are the connections . . .
  - from the mains power cord to the frequency converter
  - at the connector cable from the frequency converter to the mains network in good working order?
- If a water flow monitoring device is connected, is it functioning properly? Check the water flow monitoring device by jumping its terminals and starting the TURBOVAC.
- Is the forevacuum pressure sufficient?
- Is the vacuum chamber free of leaks?

Observe also the troubleshooting instructions for the TURBOTRONIK.

# Troubleshooting

<b>Malfunction</b>	<b>Possible cause</b>	<b>Corrective action</b>
TURBOVAC does not start.	Motor connection cable not attached, is loose or is defective. Pump has seized.	Check the motor connection cable and connect correctly; replace if necessary. Replace the pump.
TURBOVAC generates loud running noises and vibrations.	Rotor is out of balance. Bearing is defective. Pump running within the natural frequency range of the system, causing resonance.	Balance the rotor (only by the OLV Service Department). Bearings will have to be replaced (only by the OLV Service Department). Change the masses of the system or install vibration damper to isolate oscillations.
The TURBOVAC does not achieve ultimate pressure.	Measurement device is defective. Measurement gauges are soiled. Leak at the system, lines or pump. Minor grime collection at the pump. The pump is oily. Forevacuum pump with insufficient pumping speed or ultimate pressure which is too high. Leak at the power cord passage port. TURBOVAC is rotating in the wrong direction.	Check the measurement device. Clean or replace the measurement gauges. Locate the leaks. Bake out the pump; see Section 5.3. Have the pump cleaned (only by the OLV Service Department). Check ultimate pressure of the forevacuum pump or install a more powerful forevacuum pump. Locate and repair leaks (only by the OLV Service Department). Check the connector lines; interchange poles if necessary.
TURBOVAC overheats (malfunction indication at the TURBOTRONIK).	Forevacuum pressure too high. Gas volume too great / leak in the system. Ventilation unit blocked. Ambient temperature is too high. Cooling water is lacking or insufficient. Bearings are defective.	Check the forevacuum pump; install a more powerful forevacuum pump if necessary. Seal leak; install a more powerful forevacuum pump if necessary. Ensure sufficient supply of cooling air. Route cooler air to the fan or employ water cooling option. Ensure sufficient supply of cooling water. Have the pump repaired (only by the OLV Service Department).
The TURBOVAC or the vacuum chamber is contaminated with oil.	Anti-suckback valve at the forevacuum pump is defective. The TURBOVAC was not aired or improperly aired when shut down. System configured incorrectly: oil vapor streams back during forepump operation. Sorption trap is saturated.	Repair or replace the forevacuum pump. Check the airing valve and replace if indicated. Air the TURBOVAC correctly; see Section 4.6. Install a roughing line or pre-pump for a shorter period of time or install a sorption trap. Regenerate or replace the sorption trap.



## 7 Waste Disposal

The equipment may have been contaminated by the process or by environmental influences. In this case the equipment must be decontaminated in accordance with the relevant regulations. We offer this service at fixed prices. Further details are available on request.

Contaminated parts can be detrimental to health and environment. Before beginning with any work, first find out whether any parts are contaminated. Adhere to the relevant regulations and take the necessary precautions when handling contaminated parts.

Separate clean components according to their materials, and dispose of these accordingly. We offer this service. Further details are available on request.

When sending us any equipment, observe the regulations given in Section "5.2 Oerlikon Leybold Vacuum service".

### Contamination

---

### Warning



# EC Manufacturer's Declaration

in the spirit of Appendix IIb to the 98/37/EG Machinery Guidelines

We - Oerlikon Leybold Vacuum GmbH - herewith declare that operation of the incomplete machine defined below, is not permissible until it has been determined that the machine into which this incomplete machine is to be installed, meets the regulations of the EC Directive on Machinery.

When using the appropriate Oerlikon Leybold Vacuum accessories, e.g. connectors, lines, flange heaters and fans and when powering the pump with the specified frequency converters, the protection level prescribed in the EMC Guidelines will be attained.

Designation of the products      Turbomolecular pump

## Models

TURBOVAC 35 LS, 35 LS2

## Part Nos.

856 64, 856 66

TURBOVAC 50

853 99, 854 00, 854 01, 854 02, 800150V0010

TURBOVAC 151, 151 C

103 41, 856 31, 856 32, 856 33, 856 35

TURBOVAC 361, 361 C

856 70, 856 71, 856 72, 856 73, 856 74, 856 75, 856 77, 800150V0005, 800150V0018

TURBOVAC 600 C

800150V0005, 800150V0015, 800150V0017

TURBOVAC 1000 C

117 64, 15300, 854 91, 855 35, 855 36, 855 38, 855 39, 894 89

## Related, harmonized standards

■ EN 1012 - 2: 1996 Compressors and vacuum pumps. Safety requirements. Part 2: Vacuum pumps

# Declaration of Contamination of Compressors, Vacuum Pumps and Components

The repair and / or servicing of compressors, vacuum pumps and components will be carried out only if a correctly completed declaration has been submitted. **Non-completion will result in delay.** The manufacturer can refuse to accept any equipment without a declaration.

**A separate declaration has to be completed for each single component.**

This declaration may be completed and signed only by authorised and qualified staff.

Customer/Dep./Institute: _____	<b>Reason for return</b> <input checked="" type="checkbox"/> applicable please mark
Address _____	<input type="checkbox"/> <b>Repair</b> <input type="checkbox"/> chargeable <input type="checkbox"/> warranty
Person to contact: _____	<input type="checkbox"/> <b>Exchange</b> <input type="checkbox"/> chargeable <input type="checkbox"/> warranty
Phone: _____ Fax: _____	<input type="checkbox"/> exchange already arranged / received
End user: _____	<b>Return only:</b> <input type="checkbox"/> rent <input type="checkbox"/> loan <input type="checkbox"/> for credit
	<b>Calibration:</b> <input type="checkbox"/> DKD <input type="checkbox"/> Factory calibration
	<input type="checkbox"/> Quality test certificate DIN 55350-18-4.2.1

<b>A. Description of the Leybold product</b>	Failure description: _____
Material description: _____	_____
Catalog number: _____	Additional parts: _____
Serial number: _____	Application Tool: _____
Type of oil (Forevacuum pumps): _____	Application Process: _____

<b>B. Condition of the equipment</b>						
	No <sup>1)</sup>	Yes	No	<b>Contamination:</b>	No <sup>1)</sup>	Yes
1. Has the equipment been used <sup>1)</sup>	<input type="checkbox"/>	<input type="checkbox"/>	<input checked="" type="checkbox"/>	toxic	<input type="checkbox"/>	<input type="checkbox"/>
2. Drained (Product/service fluid)	<input checked="" type="checkbox"/>	<input type="checkbox"/>	<input type="checkbox"/>	corrosive	<input type="checkbox"/>	<input type="checkbox"/>
3. All openings sealed airtight	<input type="checkbox"/>	<input type="checkbox"/>	<input type="checkbox"/>	flammable	<input type="checkbox"/>	<input type="checkbox"/>
4. Purged	<input type="checkbox"/>	<input type="checkbox"/>	<input type="checkbox"/>	explosive <sup>2)</sup>	<input type="checkbox"/>	<input type="checkbox"/>
If yes which cleaning agent: _____				radioactive <sup>2)</sup>	<input type="checkbox"/>	<input type="checkbox"/>
and which method of cleaning: _____				microbiological <sup>2)</sup>	<input type="checkbox"/>	<input type="checkbox"/>
<sup>1)</sup> if answered with "No" go to <b>D.</b>				other harmful substances	<input type="checkbox"/>	<input type="checkbox"/>

<b>C. Description of processed substances (Please fill in absolutely)</b>	
1. What substances have come into contact with the equipment: Trade name and / or chemical term of service fluids and substances processed, properties of the substances; According to safety data sheet (e.g. toxic, inflammable, corrosive, radioactive)	
Tradename: _____	Chemical name: _____
a) _____	
b) _____	
c) _____	
d) _____	
2. Are these substances harmful?	No Yes
3. Dangerous decomposition products when heated?	<input type="checkbox"/> <input type="checkbox"/>
If yes, which? _____	

**<sup>2)</sup> Components contaminated by microbiological, explosive or radioactive products/substances will not be accepted without written evidence of decontamination.**

<b>D. Legally binding declaration</b>	
I / we hereby declare that the information supplied on this form is accurate and sufficient to judge any contamination level.	
Name of authorised person (block letters): _____	firm stamp
Date _____ Signatur of authorised person _____	