

Contents

1	Description	13
1.1	Design and Function	13
1.2	Standard Specification	14
1.3	Technical Data	14
2	Installation	15
2.1	Pump-Side Part of Isolation Valve	16
2.2	Filter Elements and Filter Housing	16
2.3	Oil Charge	17
3	Filter Change	18
3.1	Leybold Service	20

Warning Indicates procedures that must be strictly observed to prevent hazards to persons..



Caution Indicates procedures that must strictly be observed to prevent damage to, or destruction of the pump.

Leybold-Service

If equipment is returned to Leybold, indicate whether the equipment free of substances damaging to health or whether it is contaminated.

If it is contaminated also indicate the nature of the hazard. Leybold must return any equipment without a "Declaration of Contamination" to the sender's address.

Disposal of Waste Oil

Owners of waste oil are entirely self-responsible for proper disposal of this waste.

Waste oil from vacuum pumps must not be mixed with other substances or materials.

Waste oil from vacuum pumps (Leybold oils which are based on mineral oils) which are subject to normal wear and which are contaminated due to the influence of oxygen in the air, high temperatures or mechanical wear must be disposed of through the locally available waste oil disposal system.

Waste oil from vacuum pumps which is contaminated with other substances must be marked and stored in such a way that the type of contamination is apparent. This waste must be disposed of as special waste.

European, national and regional regulations concerning waste disposal need to be observed. Waste must only be transported and disposed of by an approved waste disposal vendor.

Chemtech Scientific provides access to this content as a courtesy.
We do not own the content contained in this document.
All rights and credit go directly to its rightful owners.
www.chemtechsci.com
Call us at: 484-424-9415



Figures

The references to diagrams, e.g. (1/2) consist of the Fig. No. and the Item No. in that order.

We reserve the right to alter the design or any data given in these Operating Instructions. The illustrations are not binding.

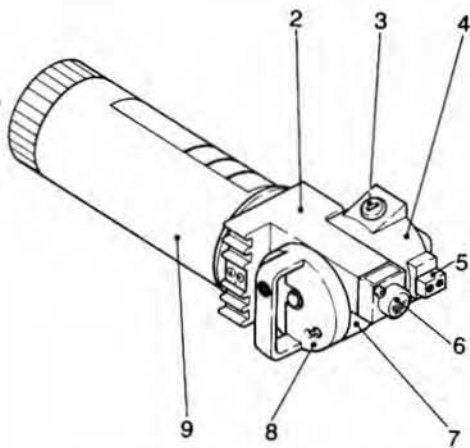

Fig. 1 CFS 16 - 25

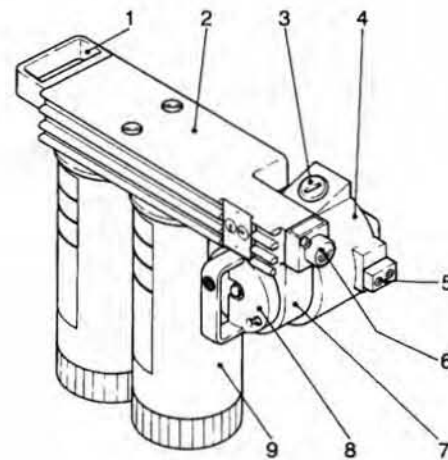

Fig. 2 CFS 40 - 65

Key to Fig. 1 and Fig. 2

- 1 Handle
- 2 Filter housing
- 3 Connection for differential pressure switch
- 4 Pump-side part of isolation valve
- 5 Connection for pressure switch
- 6 Filter status indicator
- 7 Filter-side part of isolation valve
- 8 Handle
- 9 Quick-change filter element

1 Description

1.1 Design and Function

The CFS (chemical filter with safety isolation valve) is a full-flow oil filter for TRIVAC B and BCS pumps.

It is part of the TRIVAC system.

The CFS consists of a surface-protected aluminum mount, to which one (CFS 16-25) or two (CFS 40-65) quick-change filter elements can be attached, and a cast-iron isolation valve.

All oil pumped by the TRIVAC's oil pump first passes through the isolation valve and then through the filter elements; from there it returns to the TRIVAC B/BCS via the isolation valve.

Different types of filter element are available for the CFS: particle filters (WF) and aluminium oxide particle filters (WF Alu-Part). All filter elements have a pressure relief valve which causes them to be bypassed in the event of overpressure.

The isolation valve is actuated using a handle. When in the "Change" position, the passages are closed. At the same time, a bypass is opened in the pump-side part of the valve so that the lubrication circuit in the pump is maintained. In addition, an internal locking device is released. After loosening two screws, the two valve parts can be separated.

It is then possible to change the spent filter elements away from the pump. If a second CFS is used, the filter can be changed in only a few minutes without the TRIVAC B/BCS having to be shut down.

On the housing of the CFS there is a filter status indicator.

1.2 Standard Specification

All gaskets and fittings needed for installation are supplied with the CFS.

One (CFS 16-25) or two (CFS 40-65) aluminium oxide particle filter elements (WF AluPart), sealed during shipping, are supplied.

The CFS is precleaned so that it can be used with either mineral oil (e. g. N 62 or HE-200) or perfluoropolyether (PFPE, e. g. NC 1/14 or HE 1600). For shipping it is sealed airtight in foil, together with silica gel.

The CFS has connections for an oil pressure switch and a differential pressure switch from the LSS (Limit Switch System).

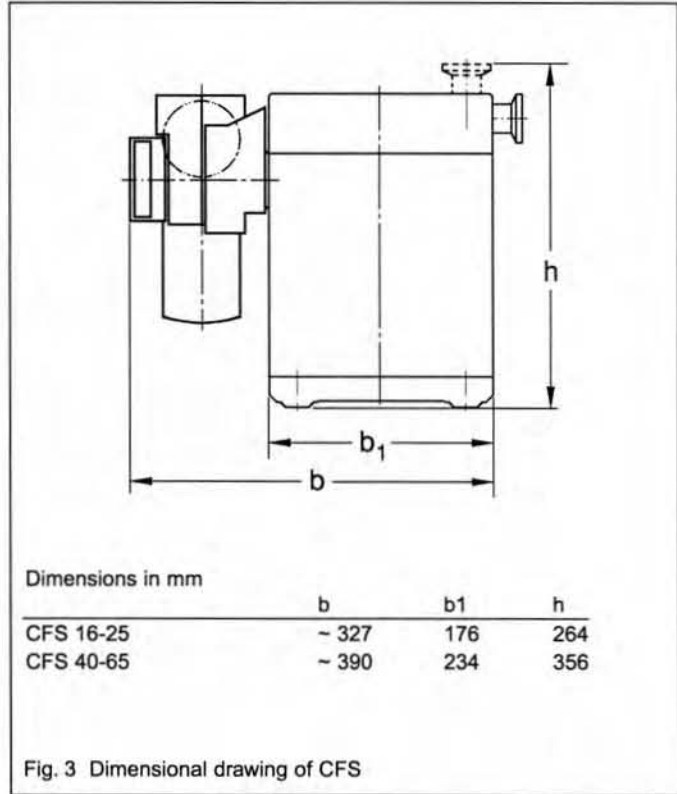

1.3 Technical Data

	16-25	40-65
Pump model TRIVAC B/BCS	S/D 16/25	S/D 40/65
Oil capacity when using WF Alu-Part	1.4 l	3.3 l
Weight, dry, ready for use	7.0 kg	15.5 kg
Chemical filter with safety isolation valve, Ref. No.	101 76	101 77
Quick-change filter elements		
WF Alu-Part 40-65, Ref. No.	189 99	189 99*
WFG 4-65 (particle filter), Ref. No.	189 90	200 09 804*
WF Alu 4-65 (aluminium oxide), Ref. No.	189 96	189 96*

* 2 needed

Key to Fig. 4

- 1 Screws
- 2 Pump-side part of isolation valve
- 3 O-rings
- 4 Screws for adapter
- 5 Adapter for CFS
- 6 Flat gasket
- 7 Pin
- 8 Cover

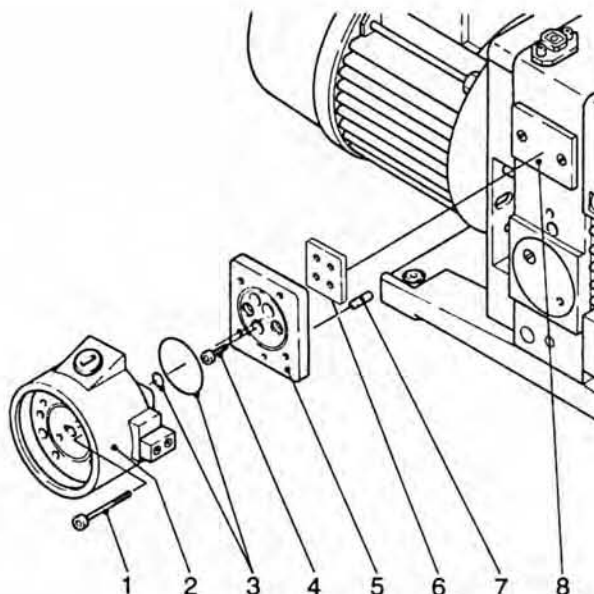

Fig. 4 Installing the pump-side part of the isolation valve

2 Installation

The CFS is freed of any oil and grease so that it can be used with either mineral oil or perfluoropolyether (PFPE). It is shipped in an airtight bag to prevent corrosion.

Caution When installing the CFS, please heed the following:

touch the interior of the CFS only with clean gloves or tools;

work in rooms that are as clean and dry as possible;

do not open the packaging of the CFS and the filter elements until immediately before use; after opening, install the CFS as quickly as possible and start up the pump;

when using PFPE, employ only Freon®1) -113 or Frigen®2)-113 as cleaning agent.

Since mineral oil and PFPE emulsify on coming into contact with one another, the CFS has to be completely cleaned and equipped with new gaskets and filter elements when changing the type of oil. It is recommendable to let LH do this work.

Warning When using PFPE, please heed all advice given in GA 07.009 "PFPE for Vacuum Pumps".



If a CFS and ARS are both connected to a TRIVAC B pump, it is advisable to replace the pump's rubber feet with anti-vibration elements. The TRIVAC BCS already has antivibration elements.

The CFS has to be installed in two steps:

Caution Important installation note
When working on the CFS, like installation, disassembly or possibly maintenance work, the CFS must always be set to the status "WECHSEL" (Change) (see Fig. 10).

Checking proper installation
During operation of the TRIVAC, i.e. after the pump has warmed up, the filter cartridges must - when correctly installed - also warm up.

First, mount the pump-side part of the isolation valve on the pump. This part can stay on the pump when the pump is run without a filter.

Then, mount the filter housing and the filter-side part of the isolation valve. This part of the CFS has to be removed and reinstalled whenever changing the filter elements.

Tools needed for installation: allen keys 6 mm, 8 mm.

®1) Registered trademark of DuPont de Nemours

®2) Registered trademark of Farbwerke Hoechst AG

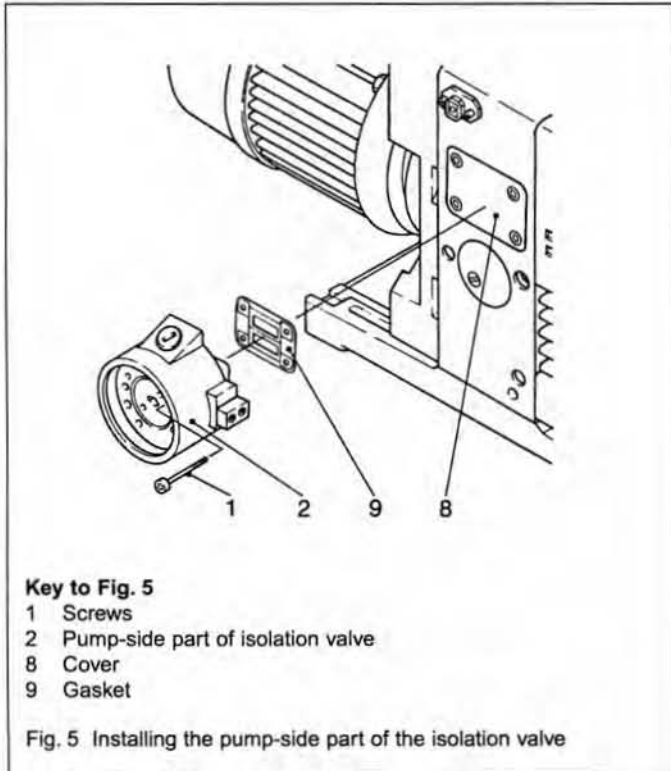

2.1 Installing the Pump-Side Part of the Isolation Valve

Remove the filter housing (6/3) from the pump-side part of the isolation valve by loosening the screws (6/4).

Remove the cover (4/8 and 5/8) with gasket from the coupling housing.

Check the sealing surface on the pump and clean it, if necessary.

CFS 16-25:

Push the pin (4/7) into the pump.

Mount the adapter (4/5) with gasket (4/6) and secure it with the screws (4/4).

Insert the O-rings (4/3).

Fasten the pump-side part of the isolation valve (4/2) with the aid of two screws (4/1). Use the holes that have recesses for the screw heads.

CFS 40-65:

Insert the gasket with crossbar (5/9). Make sure that the gasket is correctly positioned: The distances for the screw holes differ.

Fasten the pump-side part of the isolation valve (5/2) with the aid of two screws (5/1). Use the holes that have recesses for the screw heads.

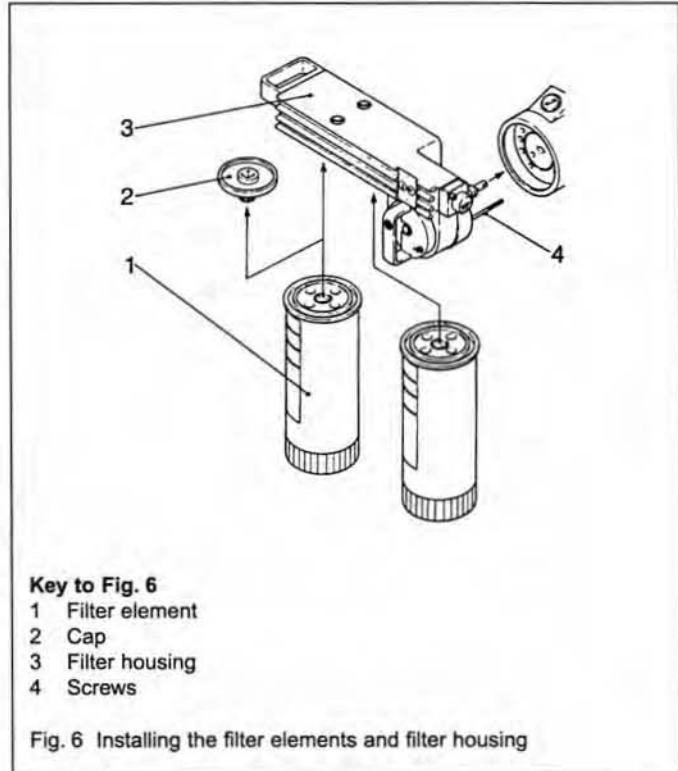

2.2 Installing the Filter Elements and Filter Housing

Remove the cap (6/2) from the filter element (6/1). It is advisable to keep the cap for sealing the filter element later on.

Moisten the sealing rings of the filter elements with oil and insert the filter elements until handtight.

Check whether the handle on the filter housing is in the "Change" position (cf. Fig. 10).

Check the fit of the gasket in the valve.

Slide the filter housing (6/3) with filter-side part of the valve onto the pump-side part of the valve. Tighten the two screws (6/4) through the handle.

Turn the handle to the "Operation" position.

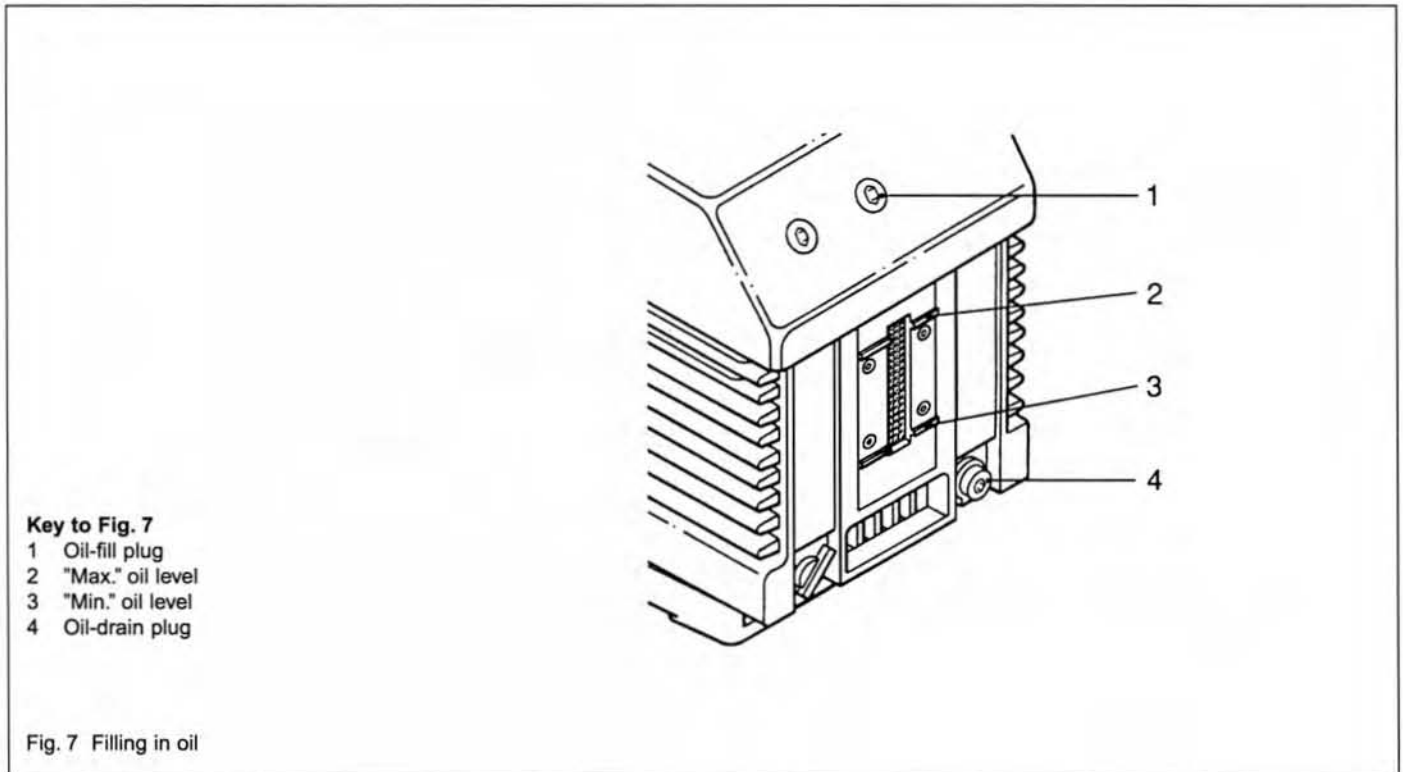

2.3 Oil Charge

Start the pump. When the pump is running, the filter elements are filled with oil and the pump's oil level drops.

Once the pump's oil level has dropped to the "min" mark (7/3), shut down the pump, remove the plug (7/1) and add oil.

Repeat this procedure until the filter elements are full.

If hazardous substances can escape from the pump, it is advisable to install an oil-fill line with shut-off valve.

Alternatively, the CFS can be prefilled on another pump having a suitable connection port. It is not possible to fill the filter elements without connecting them to a pump.

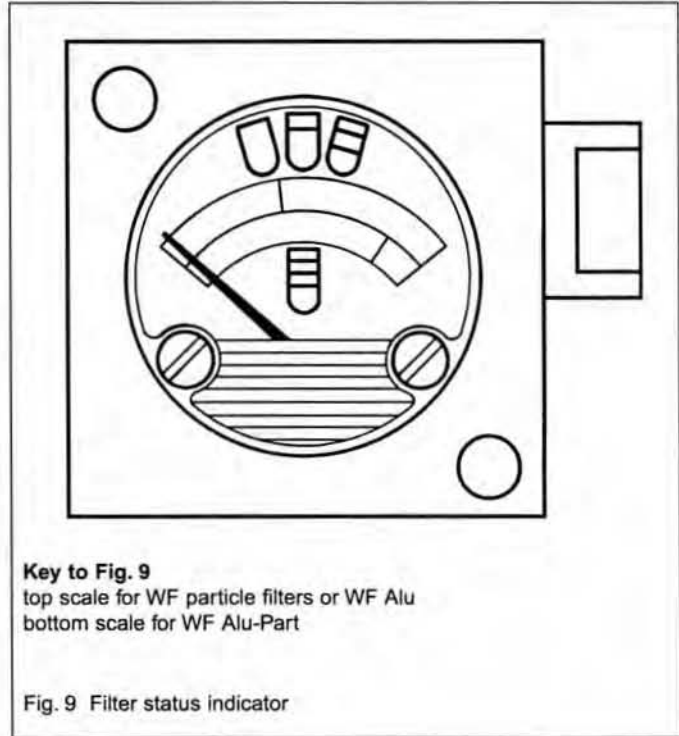
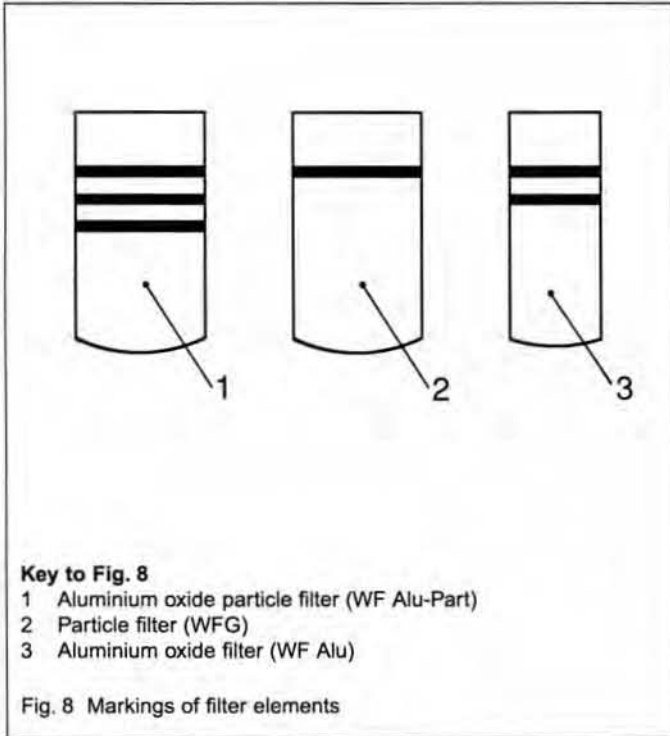

3 Filter Change

(Description for CFS 40-65; CFS 16-25 similar, only one filter element).

The filter elements have to be replaced when the filter status indicator (cf. Fig. 9) changes from green to red or when the differential or oil pressure switch of the LSS (Limit Switch System) switches over.

The top scale of the indicator is for particle filters or aluminium oxide filters; at the start of the red scale range, the pressure is approx. 2.2 bar (32 psi).

The bottom scale is for aluminium oxide particle filters; at the start of the red scale range, the pressure is approx. 4.0 bar (58 psi).

Tools needed: filter key LS 9 or LS 11, allen key 6 mm.

Set the handle (11/1) to the "Change" position.

The pump can carry on running during the filter change.

Warning The filter elements in particular can get very hot (over 100 °C / 212 °F).



Loosen the screws (11/2) through the handle and pull off the filter housing with filter elements and filter-side part of the isolation valve. Approx. 2 cm³ (1/10 fl oz) of oil will run out of the valve. If the IGS (Inert Gas System) is also connected, the oil passes via a discharge channel.

Warning The lubricant may emit **toxic gases and vapors. Take suitable precautions.**



All further work on the filter should be done under a fume hood and over an oil tray.

Observe the safety regulations.

CFS 40-65 only:

Put down the filter housing (12/3) with the top side downward.

Remove and seal the filter element (12/2).

When disposing of oil and spent filter elements, please observe the relevant environmental protection regulations.

Open the new filter elements, moisten the sealing ring with oil and mount them so that they are **handtight**.

On the CFS 40-65 part of the lubricant can be poured in via the plug screws (12/4). The filter elements must, however, be topped up on a running pump.

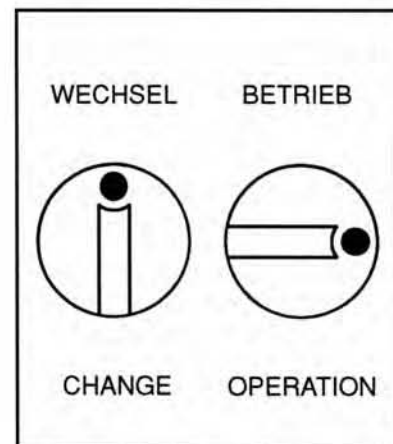
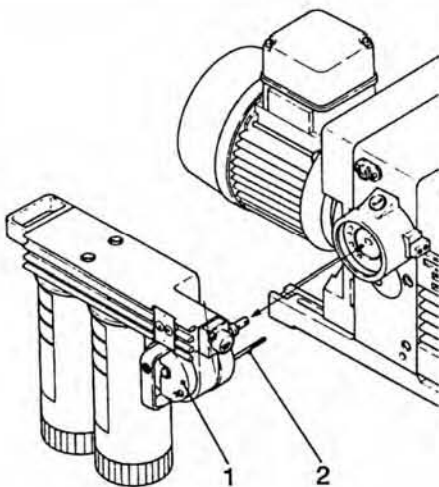
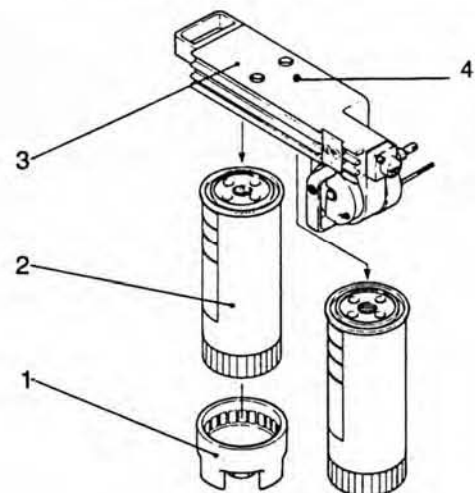

Fig. 10 Handle positions

**Key to Fig. 11**

- 1 Handle
- 2 Screws

Fig. 11 Removing filter housing

**Key to Fig. 12**

- 1 Filter key
- 2 Filter element
- 3 Filter housing
- 4 Plug screws

Fig. 12 Removing the filter elements

Reinstall the filter housing on the pump (cf. Section 2.2).

The filter elements are now filled with oil from the running pump. Once the pump's oil level has dropped to the "min" mark (7/3), shut down the pump and add oil (cf. Section 2.3).

If hazardous substances can escape from the pump, it is advisable to install an oil-fill line with shut-off valve.

If the pump is not to be shut down, the CFS has to be pre-filled on another pump having a suitable connection port.

If a second CFS is used, the pump need run without a filter for only a few minutes.

Please consult us on how to retrieve PFPE from the spent filter elements.

3.1 Leybold Service

If equipment is returned to Leybold, indicate whether the equipment free of substances damaging to health or whether it is contaminated.

If it is contaminated also indicate the nature of the hazard. For this you must use a form which has been prepared by us which we will provide upon request.

A copy of this form is reproduced at the end of these Operating Instructions: "Declaration of Contamination of Vacuum Instruments and Components".

Please attach this form to the equipment or enclose it with the equipment.

This declaration of contamination is required to meet German Law and to protect our personnel.

Leybold must return any equipment without a "Declaration of Contamination" to the sender's address.

Warning The equipment must be packed in such a way, that they will not be damaged during shipping and so that any contaminants are not released from the package.

